



# AIR-COOLED SCREW LIQUID CHILLERS

INSTALLATION, OPERATION & MAINTENANCE

New Release

Form 201.19-NM8 (804)

035-20886-000

**YCAS AIR-COOLED LIQUID CHILLERS**  
**YCAS0685EB THROUGH YCAS0965EB (3 COMPRESSOR)**  
**YCAS1065EB THROUGH YCAS1215EB (4 COMPRESSOR)**  
**STYLE G R407C**  
**50 Hz**



00258VIP

(YCAS 3 SYSTEM EPROMs)

(YCAS 4 SYSTEM EPROMs)

MICROPROCESSOR BOARD

MICROPROCESSOR BOARD

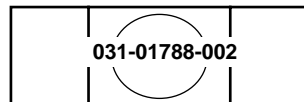
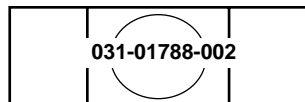

I/O BOARD #2 EPROM

I/O BOARD #2 EPROM

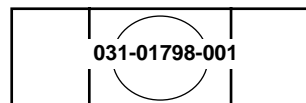
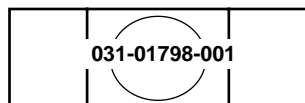

## **CHANGEABILITY OF THIS DOCUMENT**

In complying with YORK's policy for continuous product improvement, the information contained in this document is subject to change without notice. While YORK makes no commitment to update or provide current information automatically to the manual owner, that information, if applicable, can be obtained by contacting the nearest YORK Engineered Systems Service office.

It is the responsibility of operating/service personnel to verify the applicability of these documents to the equipment in question. If there is any question in the mind of operating/service personnel as to the applicability of these documents, then prior to working on the equipment, they should verify with the owner whether the equipment has been modified and if current literature is available.

# IMPORTANT!

## READ BEFORE PROCEEDING!

### GENERAL SAFETY GUIDELINES

This equipment is a relatively complicated apparatus. During installation, operation, maintenance or service, individuals may be exposed to certain components or conditions including, but not limited to: refrigerants, oils, materials under pressure, rotating components, and both high and low voltage. Each of these items has the potential, if misused or handled improperly, to cause bodily injury or death. It is the obligation and responsibility of operating/service personnel to identify and recognize these inherent hazards, protect themselves, and proceed safely in completing their tasks. Failure to comply with any of these requirements could result in serious damage to the equipment and the property in

which it is situated, as well as severe personal injury or death to themselves and people at the site.

This document is intended for use by owner-authorized operating/service personnel. It is expected that this individual possesses independent training that will enable them to perform their assigned tasks properly and safely. It is essential that, prior to performing any task on this equipment, this individual shall have read and understood this document and any referenced materials. This individual shall also be familiar with and comply with all applicable governmental standards and regulations pertaining to the task in question.

## SAFETY SYMBOLS

The following symbols are used in this document to alert the reader to areas of potential hazard:



***DANGER*** indicates an imminently hazardous situation which, if not avoided, will result in death or serious injury.



***CAUTION*** identifies a hazard which could lead to damage to the machine, damage to other equipment and/or environmental pollution. Usually an instruction will be given, together with a brief explanation.



***WARNING*** indicates a potentially hazardous situation which, if not avoided, could result in death or serious injury.

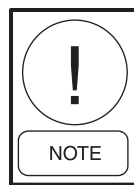

***NOTE*** is used to highlight additional information which may be helpful to you.



***External wiring, unless specified as an optional connection in the manufacturer's product line, is NOT to be connected inside the micro panel cabinet. Devices such as relays, switches, transducers and controls may NOT be installed inside the micro panel. NO external wiring is allowed to be run through the micro panel. All wiring must be in accordance with YORK's published specifications and must be performed ONLY by qualified YORK personnel. YORK will not be responsible for damages/problems resulting from improper connections to the controls or application of improper control signals. Failure to follow this will void the manufacturer's warranty and cause serious damage to property or injury to persons.***

## TABLE OF CONTENTS

<b>SECTION 1 - GENERAL CHILLER INFORMATION &amp; SAFETY.....</b>	<b>9</b>	FAN OPTIONS .....	22
INTRODUCTION .....	9	SOUND REDUCTION OPTIONS .....	22
WARRANTY .....	9	VIBRATION ISOLATION .....	22
SAFETY .....	9	UNIT NOMENCLATURE .....	23
Standards for Safety .....	9	NAMEPLATE ENGINEERING DATA .....	23
RESPONSIBILITY FOR SAFETY .....	10	PRODUCT IDENTIFICATION NUMBER (PIN) .....	24
ABOUT THIS MANUAL .....	10	DELIVERY AND STORAGE .....	25
MISUSE OF EQUIPMENT .....	10	<b>SECTION 3 - HANDLING AND STORAGE.....</b>	<b>25</b>
Suitability for Application .....	10	INSPECTION.....	25
Structural Support.....	10	MOVING THE CHILLER.....	25
Mechanical Strength.....	10	Lifting Weights .....	25
General Access .....	10	<b>UNIT RIGGING.....</b>	<b>26</b>
Pressure Systems .....	10	<b>SECTION 4 - INSTALLATION .....</b>	<b>27</b>
Electrical.....	11	LOCATION REQUIREMENTS .....	27
Rotating Parts .....	11	OUTDOOR INSTALLATIONS.....	27
Sharp Edges .....	11	INDOOR INSTALLATIONS.....	27
Refrigerants and Oils.....	11	LOCATION CLEARANCES .....	27
High Temperature and Pressure Cleaning .....	11	COMPRESSOR FEET BOLT REMOVAL .....	28
EMERGENCY SHUTDOWN .....	11	VIBRATION ISOLATORS .....	29
<b>SECTION 2 - PRODUCT DESCRIPTION.....</b>	<b>12</b>	Installation .....	29
INTRODUCTION .....	12	SHIPPING BRACES .....	29
General Description.....	12	PIPEWORK CONNECTION .....	29
Compressor.....	12	General Requirements .....	29
Evaporator .....	13	WATER TREATMENT .....	30
Condenser .....	13	PIPEWORK ARRANGEMENT .....	31
Economizer.....	14	CONNECTION TYPES & SIZES.....	31
Oil Separator/System.....	14	EVAPORATOR CONNECTIONS.....	31
Capacity Control.....	15	Option Flanges.....	31
Power and Control Panel.....	15	REFRIGERANT RELIEF VALVE PIPING .....	31
Microprocessor Controls .....	15	DUCTWORK CONNECTION .....	31
Motor Current Protection .....	15	General Requirements .....	31
Motor Protection Modules (2ACE) .....	16	ELECTRICAL CONNECTION .....	32
Current Overload.....	16	POWER WIRING.....	32
Thermal Overload.....	17	STANDARD UNITS WITH MULTI POINT POWER SUPPLY WIRING .....	32
Current Imbalance (Loaded & Unloaded)/.....	17	Units with Single-Point Power Supply Wiring.....	32
Loss of Phase.....	17	115VAC CONTROL SUPPLY TRANSFORMER....	32
Improper Phase Sequence.....	17	Remote Emergency Stop Device.....	33
MOTOR STARTING .....	20	CONTROL PANEL WIRING .....	33
KEYPAD CONTROLS .....	20	VOLTS FREE CONTACTS.....	33
Display.....	20	Chilled Liquid Pump Starter.....	33
Program .....	21	Run Contact .....	33
ACCESSORIES AND OPTIONS .....	21	Alarm Contacts .....	33
Multiple Point Power Connection .....	21	SYSTEM INPUTS.....	33
Single-Point Power Connection with Individual Circuit Protection .....	21	Flow Switch.....	33
Control Circuit Terminal Block.....	21	Remote Run / Stop.....	33
Building Automation System (BAS) Interface.....	21	Remote Print.....	33
Condenser Coil Protection .....	21	Remote Setpoint Offset – Temperature .....	33
DX EVAPORATOR AND STARTER OPTIONS .....	22	Remote Setpoint Offset – Current .....	33
UNIT ENCLOSURE OPTIONS.....	22		

## TABLE OF CONTENTS (CONT'D)

<b>SECTION 5 - COMMISSIONING .....</b>	<b>40</b>	MULTIPLE POINT POWER SUPPLY	
PREPARATION .....	40	CONNECTION .....	50
PREPARATION – POWER OFF .....	40	MULTIPLE POINT POWER SUPPLY	
Inspection .....	40	CONNECTION .....	51
Refrigerant Charge .....	40	OPTIONAL SINGLE POINT POWER SUPPLY	
Valves .....	40	CONNECTION AND INDIVIDUAL SYSTEM	
Compressor Oil.....	40	CIRCUIT BREAKERS .....	52
Fans.....	40	ELECTRICAL NOTES .....	54
Isolation/Protection.....	40	WIRING DIAGRAMS.....	56
Control Panel.....	40	WIRING DIAGRAMS .....	73
Power Connections .....	40	DIMENSIONS – YCAS0685 (SI) .....	94
Grounding.....	40	DIMENSIONS – YCAS0775 - YCAS0905 (SI) .....	96
Overloads.....	40	DIMENSIONS – YCAS0965 (SI) .....	98
Supply Voltage.....	40	DIMENSIONS – YCAS1065 - YCAS1215 (SI) .....	100
Control Transformer .....	40	TECHNICAL DATA .....	102
Switch Settings .....	41	WEIGHT DISTRIBUTION AND ISOLATOR	
Compressor Heaters.....	41	MOUNTING POSITIONS .....	103
Water System.....	41	INSTALLATION INSTRUCTIONS FOR VMC	
Flow Switch.....	41	SERIES AWR/AWMR AND CP RESTRAINED	
Temperature sensor(s).....	41	MOUNTINGS.....	120
Control Supply.....	41	COMPRESSOR COMPONENTS.....	124
Programmed Options .....	41	SYSTEM STARTUP CHECKLIST .....	130
Programmed Settings.....	41	UNIT CHECKS (NO POWER) .....	130
Date and Time.....	41	PANEL CHECKS (POWER ON – BOTH SYSTEM	
Start/Stop Schedule .....	41	SWITCHES “OFF”).....	131
Setpoint and Remote Offset.....	41	PROGRAMMED VALUES .....	131
<b>FIRST TIME START-UP .....</b>	<b>42</b>	INITIAL START-UP.....	132
Interlocks .....	42	CHECKING SUBCOOLING AND SUPERHEAT ..	132
System Switches .....	42	CHECKING ECONOMIZER SUPERHEAT .....	132
Start-up .....	42	LEAK CHECKING.....	132
Oil Pressure .....	42		
Refrigerant Flow.....	42	<b>SECTION 8 - MICRO PANEL CONTENTS....</b>	<b>134</b>
Fan Rotation .....	42	CHILLER CONTROL PANEL .....	134
Suction Superheat.....	42	PROGRAMMING AND DATA ACCESS KEYS .....	134
Expansion Valve .....	42	DISPLAY AND STATUS INFORMATION KEYS .....	134
Economizer Superheat .....	42	ON / OFF ROCKER SWITCH .....	134
Subcooling .....	42	PROGRAM & SETUP KEYS .....	134
General Operation .....	42		
<b>SECTION 6 - OPERATION .....</b>	<b>44</b>	<b>1. INTRODUCTION &amp; PHYSICAL</b>	
GENERAL DESCRIPTION .....	44	<b>DESCRIPTION.....</b>	<b>135</b>
START-UP .....	44	1.1 General .....	135
NORMAL RUNNING AND CYCLING .....	44	1.2 Keypad & Display .....	135
SHUTDOWN .....	44	1.3 Unit (Chiller) On / Off Switch.....	136
		1.4 Microprocessor Board .....	136
<b>SECTION 7 - TECHNICAL DATA .....</b>	<b>46</b>	1.5 Ancillary Circuit Boards.....	136
FLOW RATE AND PRESSURE DROP CHARTS....	46	1.6 Circuit Breakers .....	137
GLYCOL CORRECTION FACTORS .....	46	1.8 Transformers.....	138
PHYSICAL DATA - YCAS R-407C (SI UNITS).....	48	1.9 Motor Protector Modules .....	138
OPERATING LIMITATIONS AND SOUND POWER		1.10 Ems/bas Controls.....	140
DATA.....	49	1.11 Microprocessor Board Layout .....	142
ELECTRICAL DATA.....	50	1.12 Logic Section Layout .....	143
		1.13 Anti-recycle Timer.....	144

## TABLE OF CONTENTS (CONT'D)

1.14 Anti-coincidence Timer .....	144	7. CLOCK KEYS .....	175
1.15 Evaporator Pump Control .....	144	7.1 General .....	175
1.16 Compressor Heater Control .....	144	7.2 Set Time Key .....	175
1.17 Evaporator Heater Control .....	144	7.3 Set Schedule / Holiday Key .....	176
1.18 Pumpdown (Eev) Control .....	144	7.4 Manual Override Key .....	177
1.19 Alarms .....	145		
1.20 Run Status (Chiller) .....	145	<b>8. PROGRAM KEY .....</b>	<b>178</b>
1.21 Lead / Lag Compressor Selection .....	145	8.1 General .....	178
1.22 3 Or 4 Compressor Chiller Configuration .....	146	8.2 Program Key – High Discharge Pressure Cut-Out .....	178
1.23 Economizer Solenoid Control .....	146	8.3 Programming "Default" Values .....	182
<b>2. STATUS KEY: GENERAL STATUS MESSAGES &amp; FAULT WARNINGS.....</b>	<b>148</b>	8.4 Electronic Expansion Valve .....	184
2.1 General .....	148	8.5 Eev Operation .....	185
2.2 General Status Messages .....	148	8.6 Eev Programming .....	187
2.3 Unit Warnings .....	149	8.7 Eev Troubleshooting .....	188
2.4 Anticipation Control Status .....	150	8.8 3 Compressor Condenser Fan Control .....	189
2.5 Unit Fault Status Messages .....	151	8.9 4 Compressor Condenser Fan Control .....	190
2.6 System Fault (Safety) Status Messages .....	152	8.10 Service Mode: Unit Setup .....	193
2.7 Printout On Fault Shutdown .....	155	8.11 Control Inputs/outputs .....	197
<b>3. DISPLAY KEYS &amp; OPTION SWITCHES .....</b>	<b>156</b>	8.12 Sensor Calibration Charts .....	200
3.1 General .....	156	8.13 Isn Control .....	201
3.2 Chilled Liquid Temps Key .....	156	<b>SECTION 9 - MAINTENANCE .....</b>	<b>206</b>
3.3 System # Data Keys .....	157	GENERAL REQUIREMENTS .....	206
3.4 Ambient Temp Key .....	157	CONDENSER COILS .....	206
3.5 % Motor Current Key .....	158	Chiller / Compressor Operating Log .....	207
3.6 Operating Hrs / Start Counter Key .....	158	Scheduled Maintenance .....	207
3.7 Options Key & Dip Switch Settings .....	158	ON-BOARD BATTERY BACK-UP .....	207
3.8 Function Key .....	160	OVERALL UNIT INSPECTION .....	207
<b>4. PRINT KEYS .....</b>	<b>161</b>	COMPRESSOR UNIT OPERATION .....	207
4.1 General .....	161	GENERAL PERIODIC MAINTENANCE CHECKS .....	210
4.2 Oper Data Key .....	161	STANDARD UNITS .....	210
4.3 Operating Data – Software Version .....	163	<b>SECTION 10 - SPARE PARTS .....</b>	<b>211</b>
4.4 Operating Data – Remote Printout .....	163	Recommended Spares .....	211
4.5 History Key .....	164	Recommended Compressor Oils .....	211
4.6 Fault History Data – Local Display Messages .....	164	<b>SECTION 11 - TROUBLESHOOTING GUIDE .....</b>	<b>212</b>
4.7 Fault History Data – Remote Printout .....	168	LIMITED WARRANTY YORK AMERICAS ENGINEERED SYSTEMS .....	214
<b>5. ENTRY KEYS .....</b>	<b>169</b>	WARRANTY ON NEW EQUIPMENT .....	214
5.1 General .....	169	WARRANTY ON RECONDITIONED OR REPLACEMENT MATERIALS .....	214
5.2 Numerical Keypad .....	169	TEMPERATURE CONVERSION CHART ACTUAL TEMPERATURES .....	214
5.3 Enter Key .....	169	TEMPERATURE CONVERSION CHART - DIFFERENTIAL TEMPERATURES .....	214
5.4 Cancel Key .....	169	PRESSURE CONVERSION CHART - GAUGE OR DIFFERENTIAL .....	215
5.5 ↑↓ Keys .....	169		
<b>6. SETPOINTS KEYS &amp; CHILLED LIQUID CONTROL .....</b>	<b>170</b>		
6.1 General .....	170		
6.2 Chilled Liquid Temperature Control .....	170		
6.3 Local Cooling Setpoints Key .....	174		
6.4 Remote Cooling Setpoints Key .....	174		

## LIST OF TABLES

<b>TABLE 1 – MOTOR PROTECTOR DIP SWITCH SETTING .....</b>	<b>18</b>
<b>TABLE 2 – COMPRESSOR DATA.....</b>	<b>55</b>
<b>TABLE 3 – DEFAULT VALUES TABLE .....</b>	<b>183</b>
<b>TABLE 4 – PROGRAMMABLE VALUES TABLE (MINIMUM/MAXIMUM).....</b>	<b>187</b>
<b>TABLE 5 – CONDENSER FAN CONTROL AND FAN CONTACTOR DATA FOR DXST UNITS.....</b>	<b>189</b>
<b>TABLE 6 – CONDENSER FAN CONTROL AND FAN CONTACTOR DATA FOR DXST UNITS .....</b>	<b>190</b>
<b>TABLE 7 – CONDENSER FAN CONTROL AND FAN CONTACTOR DATA FOR DXST UNITS .....</b>	<b>191</b>
<b>TABLE 8 – CONDENSER FAN CONTROL AND FAN CONTACTOR DATA FOR DXST UNITS .....</b>	<b>192</b>
<b>TABLE 9 – CONDENSER FAN CONTROL AND FAN CONTACTOR DATA FOR DXST UNITS .....</b>	<b>192</b>
<b>TABLE 10 – SERVICE MODE PROGRAMMABLE VALUES.....</b>	<b>193</b>
<b>TABLE 11 – YCAS STYLE G, ACROSS THE LINE START - 50 HZ. ....</b>	<b>194</b>
<b>TABLE 12 – YCAS STYLE G, WYE DELTA START - 50 HZ. ....</b>	<b>195</b>
<b>TABLE 13 - DIGITAL OUTPUTS.....</b>	<b>197</b>
<b>TABLE 14 - ANALOG INPUTS .....</b>	<b>198</b>
<b>TABLE 15 - DIGITAL INPUTS.....</b>	<b>199</b>
<b>TABLE 16 - ANALOG OUTPUTS .....</b>	<b>199</b>
<b>TABLE 17 – ISN RECEIVED DATA .....</b>	<b>201</b>
<b>TABLE 18 – ISN TRANSMITTED DATA .....</b>	<b>201</b>
<b>TABLE 19 – ISN OPERATIONAL AND FAULT CODES .....</b>	<b>204</b>

## LIST OF FIGURES

<b>FIG. 1</b> – COMPONENT LOCATIONS.....	12	<b>FIG. 35</b> – ELEMENTARY WIRING DIAGRAM - ACROSS- THE-LINE START .....	73
<b>FIG. 2</b> – SCREW COMPRESSOR .....	13	<b>FIG. 36</b> – ELEMENTARY WIRING DIAGRAM - WYE DELTA START .....	74
<b>FIG. 3</b> – UNIT RIGGING.....	26	<b>FIG. 37</b> – CONTROL POWER TRANSFORMER KIT .....	75
<b>FIG. 4</b> – LIFTING LUGS .....	26	<b>FIG. 38</b> – ELEMENTARY WIRING DIAGRAM .....	76
<b>FIG. 5</b> – COMPRESSOR MOUNTING .....	28	<b>FIG. 39</b> – CONNECTION DIAGRAM 4 COMPRESSOR...	78
<b>FIG. 6</b> – PIPEWORK ARRANGEMENT .....	30	<b>FIG. 40</b> – CONNECTION DIAGRAM 4 COMPRESSOR...	79
<b>FIG. 7</b> – VICTAULIC GROOVE .....	31	<b>FIG. 41</b> – ELEMENTARY WIRING DIAGRAM .....	80
<b>FIG. 8</b> – FLANGE ATTACHMENTS .....	31	<b>FIG. 42</b> – CONNECTION DIAGRAM 4 COMPRESSOR...	82
<b>FIG. 9</b> – POWER PANEL SECTION.....	34	<b>FIG. 43</b> – CONNECTION DIAGRAM 4 COMPRESSOR...	83
<b>FIG. 10</b> – OPTION PANEL SECTION .....	35	<b>FIG. 44</b> – CONNECTION DIAGRAM 4 COMPRESSOR...	84
<b>FIG. 11</b> – LOGIC SECTION LAYOUT .....	36	<b>FIG. 45</b> – ELEMENTARY DIAGRAM - DXST DIRECT DRIVE CONTROL CIRCUIT.....	86
<b>FIG. 12</b> – LOGIC SECTION LAYOUT WITH CONTROL PANEL.....	37	<b>FIG. 46</b> – ELEMENTARY DIAGRAM - DXST DIRECT DRIVE CONTROL CIRCUIT.....	87
<b>FIG. 13</b> – CUSTOMER CONNECTIONS .....	38	<b>FIG. 47</b> – CONNECTION DIAGRAM SYSTEM WIRING ..	88
<b>FIG. 14</b> – CUSTOMER CONNECTIONS .....	39	<b>FIG. 48</b> – CONNECTION DIAGRAM SYSTEM WIRING ..	89
<b>FIG. 15</b> – FLOW RATE AND PRESSURE DROP CHARTS .....	46	<b>FIG. 49</b> – COMPRESSOR TERMINAL BOX, SYSTEM ...	90
<b>FIG. 16</b> – GLYCOL CORRECTION FACTORS .....	46	<b>FIG. 50</b> – MODEL YCAS0685 DIMENSIONS (SI) .....	94
<b>FIG. 17</b> – MULTIPLE POINT POWER SUPPLY CONNECTION .....	50	<b>FIG. 51</b> – MODEL YCAS0775 - 0905 DIMENSIONS (SI)	96
<b>FIG. 18</b> – MULTIPLE POINT POWER SUPPLY CONNECTION WITH INDIVIDUAL SYSTEM CIRCUIT BREAKERS .....	51	<b>FIG. 52</b> – MODEL YCAS0965 DIMENSIONS (SI) .....	98
<b>FIG. 19</b> – OPTIONAL SINGLE-POINT POWER SUPPLY CONNECTION WITH INDIVIDUAL SYSTEM CIRCUIT BREAKERS .....	52	<b>FIG. 53</b> – MODEL YCAS1065 - YCAS1215 (SI) .....	100
<b>FIG. 20</b> – ELEMENTARY WIRING DIAGRAM – DXST DIRECT DRIVE 3 COMPRESSOR .....	56	<b>FIG. 54</b> – CLEARANCES .....	102
<b>FIG. 21</b> – ELEMENTARY WIRING DIAGRAM – ACROSS THE-LINE START 3 COMPRESSOR.....	57	<b>FIG. 55</b> – CP-2-XX .....	104
<b>FIG. 22</b> – ELEMENTARY WIRING DIAGRAM – WYE DELTA START 3 COMPRESSOR .....	58	<b>FIG. 56</b> – ISOLATOR DETAILS .....	105
<b>FIG. 23</b> – CONTROL POWER TRANSFORMER KIT .....	59	<b>FIG. 57</b> – CP-2-XX .....	108
<b>FIG. 24</b> – ELEMENTARY WIRING DIAGRAM DXST DIRECT DRIVE CONTROL CIRCUIT .....	60	<b>FIG. 58</b> – ISOLATOR DETAILS .....	109
<b>FIG. 25</b> – CONNECTION DIAGRAM 3 COMPRESSOR...	62	<b>FIG. 59</b> – CP-2-XX .....	112
<b>FIG. 26</b> – CONNECTION DIAGRAM 3 COMPRESSOR POWER PANEL.....	63	<b>FIG. 60</b> – ISOLATOR DETAILS .....	113
<b>FIG. 27</b> – CONNECTION DIAGRAM 3 COMPRESSOR POWER PANEL.....	64	<b>FIG. 61</b> – CP-2-XX .....	116
<b>FIG. 28</b> – CONNECTION DIAGRAM 3 COMPRESSOR POWER PANEL.....	66	<b>FIG. 62</b> – ISOLATOR DETAILS .....	117
<b>FIG. 29</b> – CONNECTION DIAGRAM 3 COMPRESSOR ELECTRONIC PANEL.....	67	<b>FIG. 63</b> – REFRIGERANT FLOW DIAGRAM.....	120
<b>FIG. 30</b> – ELEMENTARY DIAGRAM 3 COMPRESSOR DXST DIRECT DRIVE CONTROL CIRCUIT....	68	<b>FIG. 64</b> – PROCESS AND INSTRUMENTATION DIAGRAM.....	121
<b>FIG. 31</b> – ELEMENTARY DIAGRAM DXST DIRECT DRIVE - 3 COMPRESSOR .....	69	<b>FIG. 65</b> – COMPONENT LOCATIONS.....	122
<b>FIG. 32</b> – CONNECTION DIAGRAM SYSTEM WIRING 3 COMPRESSOR.....	70	<b>FIG. 66</b> – COMPRESSOR COMPONENTS.....	124
<b>FIG. 33</b> – CONNECTION DIAGRAM STSTEM WIRING - 3 COMPRESSOR.....	71	<b>FIG. 67</b> – COMPRESSOR COMPONENTS.....	125
<b>FIG. 34</b> – ELEMENTARY WIRING DIAGRAM - 4 COMPRESSOR.....	72	<b>FIG. 68</b> – COMPRESSOR COMPONENTS.....	126
		<b>FIG. 69</b> – COMPRESSOR COMPONENTS.....	127
		<b>FIG. 70</b> – COMPRESSOR COMPONENTS.....	128
		<b>FIG. 71</b> – COMPRESSOR COMPONENTS.....	129
		<b>FIG. 72</b> – MOTOR PROTECTION MODULE .....	139
		<b>FIG. 73</b> – COMPONENT LAYOUT .....	142
		<b>FIG. 74</b> – LOGIC SECTION LAYOUT .....	143
		<b>FIG. 75</b> – SUCTION PRESSURE CUTOUT .....	153
		<b>FIG. 77</b> – ENLARGED PHOTOGRAPH OF DIP SWITCHES ON MICROPROCESSOR BOARD .....	159
		<b>FIG. 78</b> – ELECTRONIC EXPANSION VALVE .....	184
		<b>FIG. 79</b> – CONDENSER FAN CONTROL LAYOUT FOR DXST COMPRESSORS UNITS.....	189
		<b>FIG. 80</b> – CONDENSER FAN CONTROL LAYOUT FOR DXST COMPRESSORS UNITS.....	191

## SECTION 1 - GENERAL CHILLER INFORMATION & SAFETY

### INTRODUCTION

YORK YCAS chillers are manufactured to the highest design and construction standards to ensure high performance, reliability and adaptability to all types of air conditioning installations.

The unit is intended for cooling water or glycol solutions and is not suitable for purposes other than those specified in this manual.

This manual and the Microprocessor Operating Instructions contain all the information required for correct installation and commissioning of the unit, together with operating and maintenance instructions. The manuals should be read thoroughly before attempting to operate or service the unit.

All procedures detailed in the manuals, including installation, commissioning and maintenance tasks must only be performed by suitably trained and qualified personnel.

The manufacturer will not be liable for any injury or damage caused by incorrect installation, commissioning, operation or maintenance resulting from a failure to follow the procedures and instructions detailed in the manuals.

### WARRANTY

York International warrants all equipment and materials against defects in workmanship and materials for a period of one year from initial start-up, or eighteen months from delivery (whichever occurs first) unless extended warranty has been agreed upon as part of the contract.

The warranty is limited to parts only replacement and shipping of any faulty part, or sub-assembly which has failed due to poor quality or manufacturing errors. All claims must be supported by evidence that the failure has occurred within the warranty period, and that the unit has been operated within the designed parameters specified.

All warranty claims must specify the unit model, serial number, order number and run hours/starts. These details are printed on the unit identification plate.

The unit warranty will be void if any modification to the unit is carried out without prior written approval from York International.

For warranty purposes, the following conditions must be satisfied:

- The initial start of the unit should be carried out by trained personnel from an Authorized YORK Service Center. See Commissioning, page 40.
- Only genuine YORK approved spare parts, oils and refrigerants must be used. Recommendations on spare parts can be found on page 211.
- All the scheduled maintenance operations detailed in this manual must be performed at the specified times by suitably trained and qualified personnel. See Maintenance Section, page 206.
- Failure to satisfy any of these conditions will automatically void the warranty. See Warranty Policy, page 214.

### SAFETY

#### Standards for Safety

YCAS chillers are designed and built within an ISO 9002 accredited design and manufacturing organization. The chillers comply with the applicable sections of the following Standards and Codes:

- ANSI/ASHRAE Standard 15, Safety Code for Mechanical Refrigeration
- ANSI/NFPA Standard 70, National Electrical Code (N.E.C.)
- ASME Boiler and Pressure Vessel Code, Section VIII Division 1
- ARI Standard 550/590-98, Centrifugal and Rotary Screw Water Chilling Packages

In addition, the chillers conform to Underwriters Laboratories (U.L.) for construction of chillers and provide U.L./cU.L. listing label.

## RESPONSIBILITY FOR SAFETY

Every care has been taken in the design and manufacture of the unit to ensure compliance with the safety requirements listed above. However, the individual operating or working on any machinery is primarily responsible for:

- Personal safety, safety of other personnel, and the machinery.
- Correct utilization of the machinery in accordance with the procedures detailed in the manuals.

## ABOUT THIS MANUAL

The following terms are used in this document to alert the reader to areas of potential hazard.



A **Warning** is given in this document to identify a hazard which could lead to personal injury. Usually an instruction will be given, together with a brief explanation and the possible result of ignoring the instruction.



A **Caution** identifies a hazard which could lead to damage to the machine, damage to other equipment and/or environmental pollution. Usually an instruction will be given, together with a brief explanation and the possible result of ignoring the instruction.

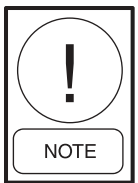

A **Note** is used to highlight additional information which may be helpful to you but where there are no special safety implications.

The contents of this manual include suggested best working practices and procedures. These are issued for guidance only, and they do not take precedence over the above stated individual responsibility and/or local safety regulations.

This manual and any other document supplied with the unit, are the property of YORK which reserves all rights. They may not be reproduced, in whole or in part, without prior written authorization from an authorized YORK representative.

## MISUSE OF EQUIPMENT

### Suitability for Application

The unit is intended for cooling water or glycol solutions and is not suitable for purposes other than those specified in these instructions. Any use of the equipment other than its intended use, or operation of the equipment contrary to the relevant procedures may result in injury to the operator, or damage to the equipment.

The unit must not be operated outside the design parameters specified in this manual.

### Structural Support

Structural support of the unit must be provided as indicated in these instructions. Failure to provide proper support may result in injury to the operator, or damage to the equipment and/or building.

### Mechanical Strength

The unit is not designed to withstand loads or stresses from adjacent equipment, pipework or structures. Additional components must not be mounted on the unit. Any such extraneous loads may cause structural failure and may result in injury to the operator, or damage to the equipment.

### General Access

There are a number of areas and features which may be a hazard and potentially cause injury when working on the unit unless suitable safety precautions are taken. It is important to ensure access to the unit is restricted to suitably qualified persons who are familiar with the potential hazards and precautions necessary for safe operation and maintenance of equipment containing high temperatures, pressures and voltages.

### Pressure Systems

The unit contains refrigerant vapor and liquid under pressure, release of which can be a danger and cause injury. The user should ensure that care is taken during installation, operation and maintenance to avoid damage to the pressure system. No attempt should be made to gain access to the component parts of the pressure system other than by suitably trained and qualified personnel.

**Electrical**

The unit must be grounded. No installation or maintenance work should be attempted on the electrical equipment without first switching OFF, isolating and locking-off the power supply. Work on live equipment must only be carried out by suitably trained and qualified personnel. No attempt should be made to gain access to the control panel or electrical enclosures during normal operation of the unit.

**Rotating Parts**

Fan guards must be fitted at all times and not removed unless the power supply has been isolated. If ductwork is to be fitted, requiring the wire fan guards to be removed, alternative safety measures must be taken to protect against the risk of injury from rotating fans.

**Sharp Edges**

The finning on the air cooled condenser coils has sharp metal edges. Reasonable care should be taken when working in contact with the coils to avoid the risk of minor abrasions and lacerations. The use of gloves is recommended.

**Refrigerants and Oils**

Refrigerants and oils used in the unit are generally non-toxic, non-flammable and non-corrosive, and pose no special safety hazards. Use of gloves and safety glasses are, however, recommended when working on the unit. The build up of refrigerant vapor, from a leak for example, does pose a risk of asphyxiation in confined or enclosed spaces and attention should be given to good ventilation.

**High Temperature and Pressure Cleaning**

High temperature and pressure cleaning methods (e.g. steam cleaning) should not be used on any part of the pressure system as this may cause operation of the pressure relief device(s). Detergents and solvents which may cause corrosion should also be avoided.

**EMERGENCY SHUTDOWN**

In case of an emergency the electrical option panel is fitted with an emergency stop switch CB4 (3 System) or CB5 (4 System) located in the bottom right of the Microprocessor Panel. Separate Circuit Breakers, CB1 (System 1), CB2 (System 2), CB3 (System 3) or CB4 (System 4) can also be used to stop the respective system in an emergency. When operated, CB4 removes the electrical supply from the control system, thus shutting down the unit.

## SECTION 2 - PRODUCT DESCRIPTION

- 1 System Fans
- 2 System 1 & 3 Power Panel
- 3 System 2 & 4 Power Panel
- 4 Control Panel
- 5 Power Entry
- 6 System 2 Compressor
- 7 Evaporator
- 8 System 4 Compressor
- 9 System 2 Condenser
- 10 Option Box

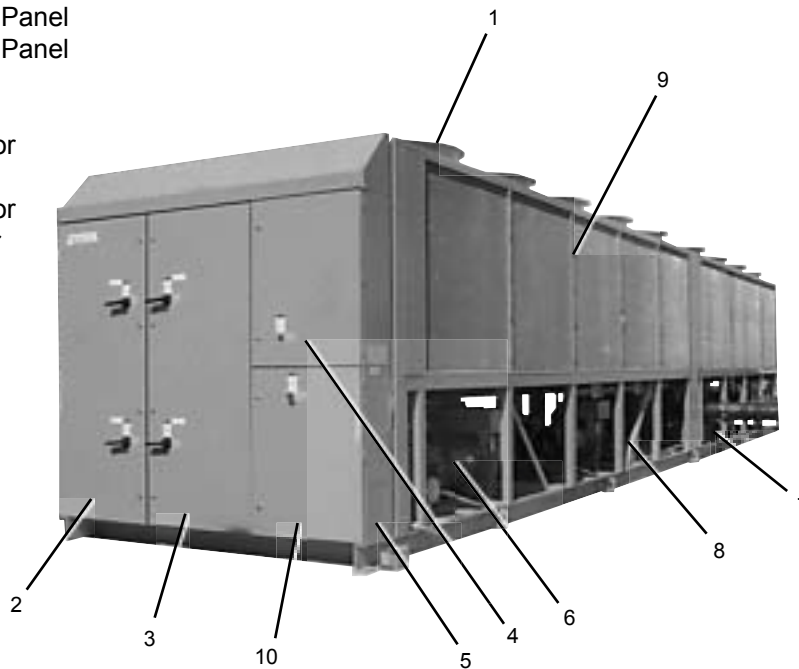

FIG. 1 – COMPONENT LOCATIONS

00258VIP

### INTRODUCTION

YORK YCAS chillers are designed for water or water-glycol cooling. All units are designed to be located outside on the roof of a building or at ground level.

The units are completely assembled with all interconnecting refrigerant piping and internal wiring, ready for field installation.

Prior to delivery, the unit is pressure tested, evacuated, and fully charged with refrigerant and oil in each of the two independent refrigerant circuits. After assembly, an operational test is performed with water flowing through the evaporator to ensure that each refrigerant circuit operates correctly.

The unit structure is manufactured from heavy gauge, galvanized steel. All external structural parts are coated with “Desert Sand” baked-on enamel powder paint. This provides a finish which, when subjected to ASTM B117, 500 hour, 5% salt spray conditions, shows breakdown of less than 1/8" either side of a scribed line (equivalent to ASTM D1654 rating of “6”).

All exposed power wiring is be routed through liquid-tight, non-metallic conduit.

### General Description

The Air Cooled Screw Chiller utilizes many components which are the same or nearly the same as a standard reciprocating chiller of a similar size. This includes modular frame rails, condenser, fans and evaporator.

The chiller consists of 3 or 4 screw compressors in a corresponding number of separate refrigerant circuits, a single shell and tube DX counterflow evaporator, economizers, an air cooled condenser, and expansion valves.

### Compressor

The semi-hermetic rotary twin-screw compressor is designed for industrial refrigeration applications and ensures high operational efficiencies and reliable performance. Capacity control is achieved through a single slide valve. The compressor is a positive displacement type characterized by two helically grooved rotors which are manufactured from forged steel. The 60 Hz motor operates at 3550 RPM to direct drive the male rotor which in turn drives the female rotor on a light film of oil.

Refrigerant gas is drawn into the void created by the unmeshing of the five lobed male and seven lobed female rotor. Further meshing of the rotors closes the rotor threads to the suction port and progressively compresses the gas in an axial direction to the discharge port. The gas is compressed in volume and increased in pressure before exiting at a designed volume at the discharge end of the rotor casing. Since the intake and discharge cycles overlap, a resulting smooth flow of gas is maintained.

The rotors are housed in a cast iron compressor housing precision machined to provide optimal clearances for the rotors. Contact between the male and female rotor is primarily rolling on a contact band on each of the rotor's pitch circle. This results in virtually no rotor wear and increased reliability, a trademark of the screw compressor.

The compressor incorporates a complete anti-friction bearing design for reduced power input and increased reliability. Four separated, cylindrical, roller bearings handle radial loads. Angular-contact ball bearings handle axial loads. Together they maintain accurate rotor positioning at all pressure ratios, thereby minimizing leakage and maintaining efficiency. A springless check valve is installed in the compressor discharge housing to prevent compressor rotor backspin due to system refrigerant pressure gradients during shutdown.

Motor cooling is provided by suction gas from the evaporator flowing across the motor. Redundant overload protection is provided using both thermistor and current overload protection.



**FIG. 2 – SCREW COMPRESSOR**

00485VIP

The compressor is lubricated by removing oil from the refrigerant using an external oil separator. The pressurized oil from the oil separator is then cooled in the condenser coils and piped back to the compressor for lubrication. The compressor design working pressure is 450 PSIG (31 bar). Each chiller receives a 300 PSIG (21 bar) low side and a 450 PSIG (31 bar) high side factory test. A 350 watt (115-1-60) cartridge heater is located in the compressor. The heater is temperature activated to prevent refrigerant condensation.

The following items are also included:

- An acoustically tuned, internal discharge muffler to minimize noise, while maintaining maximum flow performance.
- Discharge and suction shutoff valves.
- A rain-tight terminal box.
- A suction gas screen and serviceable, 0.5 - 3.0 micron full flow oil filter within the compressor housing.

### Evaporator

The system uses a high efficiency Shell and Tube type Direct Expansion Evaporator. Each of the 3 or 4 refrigerant circuits consists of 4 passes with the chilled liquid circulating back and forth across the tubes from one end to the other.

The design working pressure of the standard evaporator on the shell side is 150 PSIG (10 bar), and 350 PSIG (24 bar) for the tube (refrigerant side). The water baffles are fabricated from galvanized steel to resist corrosion. Removable heads are provided for access to internally enhanced, seamless, copper tubes. Water vent and drain connections are included.

The evaporator is equipped with a heater for protection to -20°F (-29°C) ambient and insulated with 3/4" (19 mm) flexible closed-cell foam.

The water nozzles are provided with grooves for mechanical couplings and should be insulated by the contractor after pipe installation.

### Condenser

The fin and tube condenser coils are manufactured from seamless, internally enhanced, high condensing coefficient, corrosion resistant copper tubes arranged in

staggered rows and mechanically expanded into corrosion resistant aluminum alloy fins with full height fin collars. They have a design working pressure of 450 PSIG (31 bar). Each coil is rested to 495 PSIG (34 bar).

Multiple fans move air through the coils. They are dynamically and statically balanced, direct drive with corrosion resistant glass fiber reinforced composite blades molded into low noise, full airfoil cross section, providing vertical air discharge from extended orifices for efficiency and low sound. Each fan is located in a separate compartment to prevent cross flow during fan cycling. Guards of heavy gauge, PVC coated galvanized steel are provided.

The fan motors are high efficiency, direct drive, 6-pole, 3-phase, Class- "F," current overload protected, totally enclosed (TEAO) type with double sealed, permanently lubricated ball bearings.

**Economizer  
(Models YCAS 773, 953, 1093 and 1263)**

A plate and frame heat exchanger (economizer) is fitted to both refrigerant circuits on models YCAS 773, 953, 1093 and 1263. This increases the efficiency of the system by subcooling the primary refrigerant liquid to the evaporator.

The wet vapor to the economizer is supplied by a small 15 ton TXV set for 10°F ((5.5°C) superheat the flashes off 10-20% of the liquid from the condenser. 10-12 tons are utilized for subcooling liquid refrigerant. The wet vapor is at intermediate pressure between discharge and suction (1.7 x suction) and therefore little energy is required to pump it back through the compressor to condenser pressure. This results in a very small loss to system efficiency.

The economizer provides 25°F (14°C) of additional subcooling to the liquid refrigerant which flows to the evaporator at 95°F (35°C) ambient, 55°F (13°C) RWT, 44°F (7°C) LWT. Subcooling will drop to approximately 0°F (32°C) ambient. The subcooled liquid is then fed to the primary TXV in the system. This additional subcooling results in a significant increase in the efficiency of the system. The design working pressure of the economizer is 450 PSIG (31 bar). The economizer liquid supply solenoid is activated on start-up coincident with the liquid line solenoid, after pumpdown.

The economizer operation is controlled by the economizer solenoid valve. This valve is controlled by the microprocessor. The valve will remain off for the first 3 minutes of compressor operation. After 3 minutes

of operation, the economizer solenoid valve will open if the slide valve position is >Step 47, and the pressure ratio (PR) of discharge pressure to suction pressure is greater than 2.2 using the following formula:

English:            PR        =         $\frac{DP \text{ (PSIG)} + 14.7}{SP \text{ (PSIG)} + 14.7}$

Metric :            PR        =         $\frac{DP \text{ (BAR)} + 1}{SP \text{ (BAR)} + 1}$

**Oil Separator/System**

The external oil separator, with no moving parts and designed for minimum oil carry-over, is mounted in the discharge line of the compressor. The high pressure discharge gas is forced around a 90 degree bend. Oil is forced to the outside of the separator through centrifugal action and captured on wire mesh where it drains to the bottom of the oil separator and flows to the condenser for cooling before returning to the compressor.

The oil (YORK "L" oil – a POE oil used for all refrigerant applications), which flows back into the compressor through a replaceable 0.5 - 3.0 micron oil filter, is at high pressure. This high pressure "oil injection" forces the oil into the compressor where it is fed to the bearings for lubrication. After lubricating the bearings, it is injected through orifices on a closed thread near the suction end of the rotors. The oil is automatically injected because of the pressure difference between the discharge pressure and the reduced pressure at the suction end of the rotors. This lubricates the rotors as well as provides an oil seal against leakage around the rotors to assure refrigerant compression (volumetric efficiency). The oil also provides cooling by transferring much of the heat of compression from the gas to the oil keeping discharge temperatures down and reducing the chance for oil breakdown. Oil injected into the rotor cage flows into the rotors at a point about 1.2x suction. This assures that a required minimum differential of at least 30 PSID (2.1 bar) exists between discharge and 1.2x suction, to force oil into the rotor case. A minimum of 10 PSID (0.6 bar) is all that is required to assure protection of the compressor. Oil pressure safety is monitored as the difference between suction and the pressure of the oil entering the rotor case.

Maximum working pressure of the oil separator is 450 PSIG (31 bar). Oil level should be above the midpoint of the "lower" oil sight glass when the compressor is running. Oil level should not be above the top of the "upper" sight glass.

### **Oil Cooling**

Oil cooling is provided by routing oil from the oil separator through several of the top rows of the condenser coils and back to the compressor.

### **Capacity Control**

The compressors will start at the minimum load position and provide a capacity control range from 10% - 100% of the full unit load using a continuous function slide valve. The microprocessor modulates a voltage signal to a 3-way pressure regulating capacity control valve which controls compressor capacity, independent of system pressures, and balances the compressor capacity with the cooling load. Loading is accomplished by varying pressure through the pressure regulating capacity control valve to move the slide valve against the spring pressure to promote stable smooth loading.

Automatic spring return of the slide valve to the minimum load position will ensure compressor starting at minimum motor load.

### **Power and Control Panel**

All controls and motor starting equipment are factory wired and function tested. The panel enclosures are designed to IP55 and are manufactured from powder painted galvanized steel.

The Power and Control Panel are divided into power sections for each compressor and associated fans, a control section and an electrical options section. The power and control sections have separate hinged, latched, and gasket sealed doors equipped with wind struts, (Fig 1, page 12).

### **Each power compartment contains:**

Compressor and fan starting contactors, fan motor external overloads, control circuit serving compressor capacity control, compressor and fan contactor coils and compressor motor overloads.

Current transformers in the 2ACE module provide for the compressor motor overload protection and sense current in each phase. This protects the compressor motors from damage due to: low current input, high input current, unbalanced current, single phasing, phase reversal, and compressor locked rotor.

### **The control section contains:**

ON/OFF switch, microcomputer keypad and display, microprocessor board, I/O expansion board, relay boards and power supply board.

### **The options sections contain:**

A control circuit transformer complete with service switch providing 115/1/60 Hz power to the unit control system.

Electrical options as described in "Accessories and Options."

### **Microprocessor Controls**

The microprocessor has the following functions and displays:

- A liquid crystal 40 character display with text provided on two lines and light emitting diode backlighting outdoor viewing.
- A color coded, 35 button, sealed keypad with sections for Display, Entry, Setpoints, Clock, Print, Program and Unit ON/OFF.

The standard controls shall include: brine chilling, thermal storage, automatic pump down, run signal contacts, demand load limit from external building automation system input, remote reset liquid temperature reset input, unit alarm contacts, chilled liquid pump control, automatic reset after power failure, automatic system optimization to match operating conditions.

The software is stored in non-volatile memory (EPROM) to eliminate chiller failure due to AC power failure. The Programmed Setpoint are stored in lithium battery backed memory.

### **Motor Current Protection**

The microprocessor motor protection provides high current protection to assure that the motor is not damaged due to voltage, excess refrigerant, or other problems that could cause excessive motor current. This is accomplished by sending a current signal proportional to motor current from the Motor Protector module to the Power Supply Board where the signals are conditioned and routed to the I/O Expansion board to be multiplexed and sent to the Microprocessor Board. If the motor current exceeds the 115% FLA trip point after 3 seconds of operation on either Wye-Delta or ACL starters, the micro will shut the system down and lock it out after one fault. A manual reset of the respective system switch is required to clear the fault and restart the system. A thorough check of the motor, wiring, and refrigerant system should be done before restarting a system that has faulted on high motor current.

The micro also provides low motor current protection when it senses a motor current less than 10% FLA. The micro will shut the system down whenever low motor current is sensed and will lock out a system if three faults occur in 90 minutes. Low motor current protection is activated 4 seconds after start on both Wye-Delta and ACL starters to assure the motor starts, the system doesn't run without refrigerant, the motor protector is not tripped, and the mechanical high pressure cut-out is not tripped. Once the system is locked out on Low Motor Current, it must be manually reset with the system switch. See also Motor Protection Module section below.

The micro senses low motor current whenever a HPCO or Motor Protector contact opens. This occurs because the MP and HPCO contacts are in series with the motor contactor. Whenever either of these devices are open, the contactor de-energizes and the motor shuts down. Since the micro is sending a run signal to the contactor, it senses the low motor current below 10% FLA and shuts the system down.

**Motor Protection Modules (2ACE)**

The mechanical motor protector is a Texas Instruments 2ACE Three Phase Protection Module (Fig. 73) provides thermal and current motor overload protection. This module also protects against phase to phase current imbalance, over current, under current, and phase rotation. The modules, mounted in the power panels, utilizes a 7 segment display which provides operating status and fault diagnostic information. The 7 segment

<b>HAXXX</b>	Normal motor OFF display. Sequentially sweeps through the motor protection dip switch setting.
<b>0</b>	Normal - no fault detected (Running)
<b>Flashing "0"</b>	Motor off or unloaded < 5A (Running) AC current level.
<b>1</b>	High current fault.
<b>2</b>	Loaded phase to phase current imbalance $\geq 17\%$ .
<b>3</b>	Unloaded phase to phase current imbalance $\geq 25\%$ .
<b>4</b>	Improper incoming phase rotation.
<b>5</b>	High motor temperature. Trip point = 13kW, reset = 3.25kW.
<b>6</b>	Communication error.
<b>7</b>	Unload imbalance ( $\geq 50\%$ )
<b>8</b>	Phase Loss ( $> 60\%$ )
<b>E</b>	Out of range of RLA calibration.
<b>Other symbols</b>	Defective module or supply voltage.

Working voltage 18 - 30 VAC, 24 VAC nominal.  
 Low voltage trip = 15 VAC.

display will display either a stationary or a flashing alphanumeric value which can be decoded by the operator. A list of the codes is shown in the table below.

Whenever a motor protector trips, the motor protector contacts wired in series with the motor contacts opens and the motor contactor de-energizes causing the motor to stop. The micro senses the low motor current and shuts the system down. The micro will try two more starts before locking the system out. The system locks out because the motor protector is a manual reset device. After the first start, the modules' contacts will be open preventing the motor contactors from energizing. Power must be removed and reapplied to reset the module.

**Current Overload**

The 2ACE module design uses one integral current transformer per phase to provide protection against rapid current overload conditions. The module responds to changes in current and must be calibrated using DIP switches located on the module. Integral trip curves allow for in-rush currents during Wye-Delta, part wind, or ACL starts without nuisance tripping.

To check the factory setting of the 2ACE module current overload trip value. See Table 1 (pages 18 and 19).

For the location of the dip switches and determining the OPEN side of the switches, refer to Figure 73. As indicated, to place a switch in the ON position requires pushing the switch to the left.

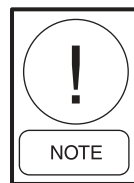

*A switch must be pushed to the left to place the switch in the ON position. The numerical value for the combination of "ON" switches equals the overload setting.*



*It is recommended that a YORK Service Technician or the YORK factory be consulted before changing these settings for any reason, since damage to the compressor could result. Changes should never be made unless it is verified that the settings are incorrect.*



***Anytime a dip switch change is made, power must be cycled off and on to the module to reprogram the module to the new value.***

### **Thermal Overload**

Three PTC (positive temperature coefficient) thermistors in the motor windings provides thermal protection. The sensor resistance stays relatively constant at  $1k\Omega$  until a temperature of  $266^{\circ}\text{F}$  ( $130^{\circ}\text{C}$ ) is sensed. The sensor experiences a rapid rise in resistance beyond this temperature. Whenever the resistance of one of the sensors reaches  $13k\Omega, \pm 3k\Omega$ , the 2ACE module trips, which ultimately de-energizes the motor's pilot circuit. Reset is manual after the motor cools and the sensor resistance drops to  $3.25k\Omega, \pm 0.5 k\Omega$ .

### **Current Imbalance (Loaded & Unloaded)/**

#### **Loss of Phase**

A 2 second delay at start-up allows for any imbalances resulting during normal starting conditions. After this initial delay, the 2ACE module compares the "Operating Current" to the measured half line current. The "Operating Current" is given by  $0.65 \times$  factory overload current setting.

An *unloaded compressor condition* occurs when any measured half line current is less than the "Operating Current." A current imbalance exceeding an unloaded level of 25% will result in the motor pilot circuit being de-energized.

A *loaded compressor condition* occurs when any measured half line current is greater than or equal to the "Operating Current." A current imbalance exceeding a loaded level of 17% will result in the motor pilot circuit being de-energized.

*Imbalance* is defined as  
(High Phase - Low Phase)/High Phase

### **Improper Phase Sequence**

The 2ACE module calculates the phase sequence at start-up using the three current transformers to determine whether the three phase sequence on the load side of the main contactor is miswired. Upon detection of a miswired motor load, the module will de-energize the main contactor pilot circuit within 50 millisecond response time.

Additional information on the 2ACE MP module may be found on page 138.

**TABLE 1 – MOTOR PROTECTOR DIP SWITCH SETTING - (ACROSS THE LINE START - 50 HZ)**

Model No.	Volt. Code	Chiller Name- - Plate RLA	No. Leads per Phase	Motor Protector									
				MP OL Value Set	Dip Switch Settings on MP								
					128	64	32	16	8	4	2	1	
0685 Sys 1 & 2	50	99	1	134	1	0	0	0	0	0	1	1	0
685 Sys 3	50	162	2	219	1	1	0	1	1	0	0	1	1
0775	50	128	1	173	1	0	1	0	1	1	0	0	1
0835 Sys 1	50	163	2	220	1	1	0	1	1	1	0	0	0
0835 Sys 2 & 3	50	128	1	173	1	0	1	0	1	1	0	0	1
0905	50	163	2	209	1	1	0	1	0	0	0	0	1
0965 Sys 1 & 2	50	155	2	200	1	1	0	0	1	0	0	0	0
0965 Sys 3	50	148	2	189	1	0	1	1	1	1	0	0	1
1065	50	128	1	173	1	0	1	0	1	1	0	0	1
1135 Sys 1 & 2	50	162	2	219	1	1	0	1	1	0	0	1	1
1135 Sys 3 & 4	50	128	1	173	1	0	1	0	1	1	0	0	1
1215	50	162	2	219	1	1	0	1	0	0	0	1	1

\* Indicates one lead/phase through motor protector.

**TABLE 2 – MOTOR PROTECTOR DIP SWITCH SETTING - (Wye Delta Start - 50 Hz)**

Model No.	Volt. Code	Chiller Name- - Plate RLA	No. Leads per Phase	Motor Protector								
				MP OL Value Set	Dip Switch Settings on MP							
					128	64	32	16	8	4	2	1
0685 Sys 1 & 2	50	99	1	134	1	0	0	0	0	1	1	0
685 Sys 3	50	162	2	219	1	1	0	1	1	0	1	1
0775	50	128	2	173	1	0	1	0	1	1	0	1
0835 Sys 1	50	163	2	220	1	1	0	1	1	1	0	0
0835 Sys 2 & 3	50	128	2	173	1	0	1	0	1	1	0	1
0905	50	163	2	220	1	1	0	1	1	1	0	0
0965 Sys 1 & 2	50	155	2	209	1	1	0	1	0	0	0	1
0965 Sys 3	50	148	2	200	1	1	0	0	1	0	0	0
1065	50	128	2	173	1	0	1	0	1	1	0	1
1135 Sys 1 & 2	50	162	2	219	1	1	0	1	1	0	1	1
1135 Sys 3 & 4	50	128	2	173	1	0	1	0	1	1	0	1
1215	50	162	2	219	1	1	0	1	1	0	1	1

\* Indicates one lead/phase through motor protector.

## MOTOR STARTING

Two types of compressor motor starting are available: Across-the-Line and optional Wye-Delta Open Transition Starter.

Across-the-Line starters will utilize one contactor and one start relay per compressor. The optional Wye-Delta starter utilizes 4 motor contactors, a transition delay relay, a start relay, and a start-wye relay.

The Wye-Delta start allows inrush current to be limited to approximately 33% LRA for the first 4 to 7 seconds, with current increasing to normal running current when the Delta connection is completed.

When the micro initiates a start signal at Relay Output Board #1 (SYS 1) Terminal 20 or Relay Output Board #2 (SYS 2) Terminal 20 to run a compressor, the 1CR (SYS 1) or 2CR (SYS 2) relay is energized. The transition of the 1CR (SYS 1) or 2CR (SYS 2) relay contacts energizes the 1S (SYS 1) or 2S (SYS 2) relay approx. 16ms later. The 1S/2S contacts in turn energize the 1M (SYS 1) or 3M (SYS 2) motor contacts 16ms later. This completes the “WYE” connection of the motor start. At the same time, the normally closed 1S/2S auxiliary interlock contact opens preventing the 2M and 1 TRX (SYS 1) or 4M and 2 TRX (SYS 2) motor contactors from energizing. 2 sets of auxiliary contacts from 1M (SYS 1) or 3M (SYS 2) close, interlocking the 1M (SYS 1) or 3M (SYS 2) contactors, keeping them energized in parallel with 1S (SYS 1) or 2S (SYS 2).

The “WYE” connection of the motor start is enabled for 4 to 7 seconds depending upon motor current as sensed by the microprocessor. The transition to Delta takes 7 seconds if current is below 110% FLA. If motor current exceeds 110% FLA, the transition is made to Delta as long as the WYE has been enabled for at least 4 seconds.

After the “WYE” connection is enabled for 4 to 7 seconds, the 1TR (SYS 1) or 2TR (SYS 2) transition delay relay is enabled by the microprocessor from Relay Output Board #1 Terminal 8 (SYS 1) or Relay Output Board #2 Terminal 6 (SYS 2). The 1TR (SYS 1) or 2TR (SYS 2) contacts open, de-energizing 1S (SYS 1) or 2S (SYS 2). 1M (SYS 1) or 3M (SYS 2) remain energized through 2 sets of interlocking contacts 1M (SYS 1) or 3M (SYS 2). Opening of the 1TR (SYS 1) or 2TR (SYS 2) contacts deenergizes 1S/2S and closes the normally closed 1S (SYS 1) or 2S (SYS 2) contacts, energizing, 1TRX (SYS 1) or 2TRX (SYS 2). 1TRX or 2TRX

subsequently energizes motor contactor 2M (SYS 1) or 4M (SYS 2), completing the “DELTA” connection of the motor.

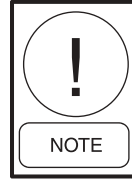

***Systems 3 and 4 operate in a similar sequence***

***1TR, 1TRX, 2TR, 2TRX, 3TR, 3TRX, 4TR, and 4TRX are NOT "timing" relays. These devices are simply pilot relays identical to 1CR-4CR.***

## KEYPAD CONTROLS

### Display

Parameters are displayed in English (°F and PSIG) or Metric (°C and Bars) units, and for each circuit, the following items can be displayed:

- Return and leaving chilled liquid, and ambient temperature.
- Day, date and time. Daily start/stop times. Holiday and Manual Override status.
- Compressor operating hours and starts. Automatic or manual lead/lag. Lead compressor identification.
- Run permissive status. No cooling load condition. Compressor run status.
- Anti-recycle timer and anti-coincident start timer status per compressor.
- System suction (and suction superheat), discharge, and oil pressures and temperatures.
- Percent full load compressor motor current per phase and average per phase. Compressor capacity control valve input steps.
- Cutout status and setpoints for: supply fluid temperature, low suction pressure, high discharge pressure and temperature, high oil temperature, low and high ambient, phase rotation safety, and low leaving liquid temperature.
- Unloading limit setpoints for high discharge pressure and compressor motor current.
- Status of: evaporator heater, condenser fans, load and unload timers, chilled water pump.
- “Out of range” message.
- Up to 6 fault shut down conditions. (4 in YCAS 3 Compressor and YCAS 4 Compressor).

The standard display language is English, with 4 other languages available.

**Entry** – Used to confirm Set Point changes, cancel inputs, advance day, and change AM/PM.

**Setpoints** – For setting chilled liquid temperature, chilled liquid range, remote reset temperature range.

**Clock** – Used to set time, daily or holiday start/stop schedule and manual override for servicing.

**Print** – Used to display or print operating data or system fault shutdown history for last six faults. (4 in YCAS 3 Compressor and YCAS 4 Compressor models). Printouts through an RS-232 port via a separate printer.

### **Program**

For setting low leaving liquid temperature cutout, 300 to 600 second anti-recycle timer, average motor current unload point, liquid temperature setpoint reset signal from YORK ISN or building automation system.

Additional functions (password protected) for programming by a qualified service technician:

Cutouts for low and high ambient, low suction pressure and high discharge pressure, refrigerant type, high discharge pressure unload setpoint.

## **ACCESSORIES AND OPTIONS**

### **Multiple Point Power Connection**

Standard field power wiring connection on all models is Multiple Point Power Connection. Field provided power supply circuits, with appropriate branch circuit protection, are connected to factory provided terminal blocks, non-fused disconnect switches or circuit breakers.

### **Single-Point Power Connection with Individual Circuit Protection**

A single-point supply circuit with field provided protection is connected to a factory provided terminal block or non-fused disconnect switch located in the options compartment. Factory wiring is provided from the terminal block or disconnect switch to factory supplied internal branch circuit breakers with lockable external handles in the power compartments.

### **Control Circuit Terminal Block**

A 120V, 20A control circuit power terminal strip located in the control panel to accept a field provided control power supply, rather than the standard factory mounted control circuit transformer. The supply with appropriate branch circuit protection in accordance with applicable Local codes, provides the unit control circuit power supply via the panel mounted Emergency Stop Switch.

### **Building Automation System (BAS) Interface**

Provides a means to reset the leaving chilled liquid temperature or percent full load amps (current limiting) from the BAS (Factory-mounted):

Printed circuit board to accept 4 to 20mA, 0 to 10VDC, or dry contact closure input from the BAS.

A YORK ISN Building Automation System can provide a Pulse Width Modulated (PWM) signal direct to the standard control panel via the standard on-board RS485 port.

### **Condenser Coil Protection**

The standard condenser coils have Aluminum fins, copper tubes, and galvanized steel supports for generally adequate corrosion resistance. However, these materials are not adequate for all environments.

The following options provide added protection:

**Black fin condenser coils** – Condenser coils constructed using black epoxy coated Aluminum fin stock for corrosion resistance comparable to copper fin coils in typical seashore locations.

**Copper fin condenser coils** – Coils constructed with corrosion resistant copper fins. Not recommended in areas where units may be exposed to acid rain.

**Phenolic coated condenser coils** – Completed condenser coil assemblies are covered with a cured Phenolic coating. Probably the most suitable selection for seashore locations where salt spray may come into contact with the fins, and other corrosive applications except: strong alkalis, oxidizers, and wet bromine, chlorine, and fluorine in concentrations greater than 100 PPM.

## DX EVAPORATOR AND STARTER OPTIONS

**300 PSIG (21 bar) Waterside Design Working Pressure** – The DX evaporator waterside is designed and constructed for 300 PSIG (21 bar) working pressure. (Factory-mounted)

**1-1/2" (38 mm) Insulation** – Double thickness insulation provided for enhanced efficiency.

**Flange Accessory** – Consists of raised face flanges to convert grooved water nozzles to flanged evaporator connections. Includes companion flanges for field-mounting. See Page 31.

**Remote DX Evaporator** – Includes the main condensing unit less the evaporator, refrigerant and liquid line devices. The insulated evaporator and field accessory kits per refrigerant circuit are supplied separately. The condensing unit is shipped with a nitrogen holding charge and the evaporator is shipped with a nitrogen holding charge.

**Flow Switch Accessory** – Johnson Controls model F61MG-1C Vapor-proof SPDT, NEMA 4X switch, 150 PSIG (10 bar) DWP, -20°F to 250°F (-29°C to 121°C), with 1" NPT (IPS) connection for upright mounting in horizontal pipe. A flow switch must be field installed with each unit. Optional 300 PSIG switch available.

**Star-Delta Compressor Motor Starter** – Provides approximately 65% reduced inrush current compared to across-the-line start (Factory-mounted).

## UNIT ENCLOSURE OPTIONS

**Wire enclosure** – Heavy gauge welded wire mesh guards mounted on the exterior of the unit (Factory- or field-mounted).

**Louvered panels and wired guards** – Louvered panels mounted over the exterior condenser coil faces, and heavy gauge welded wire mesh guards mounted around the bottom of the unit (Factory- or field-mounted).

**Louvered panels (condenser coils only)** – Louvered panels are mounted over the exterior condenser coil faces on the sides of the unit to visually screen and protect the coils (Factory- or field-mounted).

**Louvered panels (full unit) enclosure** – Louvered panels over condenser coils and around the bottom of the unit (Factory- or field-mounted).

## FAN OPTIONS

**High static fans:** Fans and motors suitable for High External Static conditions to 100 Pa.

## SOUND REDUCTION OPTIONS

**Low speed fans** – Reduced RPM fan motors and alternative fan selection for low noise applications.

**Compressor sound enclosures** – Acoustically treated metal compressor enclosures.

## VIBRATION ISOLATION

**Neoprene pad isolation** – Recommended for normal installations. (Field-mounted)

**1" (25 mm) spring isolators** – Level adjustable, spring and cage type isolators for mounting under the unit base rails (Field-mounted).

**2" (51 mm) seismic spring isolators** – Restrained Spring-Flex Mountings incorporate welded steel housing with vertical and horizontal limit stops. Housings designed to withstand a minimum 1.0 g accelerated force in all directions to 2" (51 mm). Level adjustable, deflection may vary slightly by application. (Field-mounted).

BASIC PART NUMBER

# YCAS00905EB46YGA

<b>1</b>	<b>2</b>	<b>3</b>	<b>4</b>	<b>5</b>	<b>6</b>	<b>7</b>	<b>8</b>	<b>9</b>	<b>10</b>	<b>11</b>	<b>12</b>	<b>13</b>	<b>14</b>	<b>15</b>
BASE PRODUCT TYPE				NOMINAL CAPACITY				UNIT DESIGNATOR	REFRIGERANT	VOLTAGE/STARTER			DESIGN/DEVELOPMENT LEVEL (STYLE)	
Y	C	A	YORK : Chiller : Air-Cooled S : Screw	#	#	#	Tons 0685 0775 0835 0905 0965 1065 1135 1215	E High-Efficiency S Standard G High Ambient	B : R-407C C : R-22	5	0	: 380/3/50 X : Wye (Star) Delta Y : Across-the-Line	G	A : Design Series G : Engineering Change or PIN Level

OPTIONS MODEL NUMBER

<b>16 17 18 19</b> POWER FIELD	<b>20 21 22 23 24 25 26 27 28</b> CONTROLS FIELD	<b>29 30 31 32 33 34 35 36 37</b> COMPRESSOR / PIPING FIELD
X X : Standard Power Option M D : MP NF Disconnects M B : MP Circuit Breakers S D : SP NF Disconnects S X : SP TB B X : SP Circuit Breaker S B : SP TB w/ Separate System Circuit Breakers D B : SP NF Disconnect w/ Separate System Circuit Breakers C S : SP Supply w/ Separate Disconnect Switch C S : SP w/ Separate Disconnect Switch Q Q : Special Power Option  C : Control Circuit Power Terminal Strip (std) Q : Special Transformer Required T : Control Transformer Required X : No Option Required Q : Special Quote	X : No Option Required Q : Special Quote  X T : No BAS Reset / Offset Required C : Temp Reset / Offset B : Current Reset / Offset Q : Both Temp and Current Reset / Offset Q : Special BAS Reset / Offset Required  X : English LCD & Keypad Display (std) S : Spanish LCD & Keypad Display F : French LCD & Keypad Display G : German LCD & Keypad Display I : Italian LCD & Keypad Display Q : Special LCD & Keypad Display  X : No Option Required Q : Special Quote  L : N. American Safety Code C : European Safety Code N : No Listing Q : Special Safety Code  X : No Option Required Q : Special Quote X P : No Pump Control Required Q : Pump Control Required X : Special Pump Control Required Q : No Remote Control Panel Required X : Optiview Remote Control Panel Required Q : Special Remote Control Panel Required X : No Sequence Kit Required S : Sequence Kit Required Q : Special Sequence Kit Required	NUM : Leaving Water Temp = Degrees TS : Thermal Storage QQ : Special LWT Requirements X : No Chicago Code Kit Required C : Chicago Code Kit Required S : Service Isolation Valve B : Both Isolation Valve and Chicago Code Q : Special Chicago Code Kit Required X : Standard Valves Required Q : Special Optional Valves Required X : No Option Required Q : Special Quote X : No Option Required Q : Special Quote X : No Option Required Q : Special Quote X : No Option Required Q : Special Quote X : No Option Required Q : Special Quote

**MP** = Multiple Point  
**SP** = Single-Point  
**NF** = Non-Fused  
**TB** = Terminal Block  
**Ser.** = Service  
**TS** = Thermal Storage  
**Ind. Sys. Brkr. & L. Ext. Handles** = Individual System Breaker & Lockable External Handle

UNIT NOMENCLATURE  
NAMEPLATE ENGINEERING DATA

EXAMPLES:

16	17	18	19	20	21	22	23	24	25	26	27	28	29	30	31	32	33	34	35	36	37	38	39	40	41	42	43	44	45	46	47	48	49	50	51	52	53	54	55		
X	X	X	X	X	X	X	X	X	L	X	X	X	X	X	X	X	X	X	X	X	X	X	X	X	X	X	A	X	X	X	X	X	X	X	X	X	X	X	X	X	X
S	D	T	C	A	T	S	R	L	X	P	R	S	2	5	C	X	1	X	X	X	X	3	D	W	S	A	R	X	B	X	X	4	B	X	X	L	X	S	D		

38 39 40 41 42 43 44

EVAP. FIELD

X  
3  
Q  
X  
D  
Q  
X  
W  
V  
Q  
X  
S  
D  
Q  
M  
A  
S  
F  
T  
I  
P  
D  
O  
E  
U  
Q  
X  
R  
Q

- : 150PSIG DWP
- : 300PSIG DWP
- : Special DWP
- : 3/4" Evaporator Insulation
- : 1 1/2" Evaporator Insulation
- : Special Evaporator Insulation
- : No Flanges Required
- : Weld Flanges Required
- : Vitaulic Flanges Required
- : Special Flanges Required
- : No Flow Switch
- : Flow Switch
- : Differential Pressure Switch
- : Special Flow Switch
- : Multinational Pressure Vessel Codes
- : ASME Pressure Vessel Codes
- : Australian Pressure Vessel Codes
- : French Pressure Vessel Codes
- : German Pressure Vessel Codes
- : Italian Pressure Vessel Codes
- : Polish Pressure Vessel Codes
- : Sweden SAQ Pressure Codes
- : Austian TUV Pressure Vessel Codes
- : European "CE" Pressure Vessel Directive
- : Dutch Pressure Pressure Vessel Codes
- : Special Pressure Vessel Codes
- : Standard Evaporator
- : Remote Evaporator
- : Special Evaporator Requirements
- X : No Option Required
- Q : Special Quote

45 46 47

CONDENSER FIELD

X  
B  
C  
P  
Q  
X  
Q

- : Aluminum
- : Pre-Coated
- : Copper
- : Post-Coated
- : Special Coil
- : No Option
- : Special Quote
- X : TEAO Fan Motors
- Q : Special Fan Motors

48 49 50 51 52 53 54

CABINET FIELD

X  
1  
2  
3  
4  
5  
6  
7  
8  
Q  
X  
P  
B  
Q  
D  
X  
Q  
X  
Q  
X  
L  
H  
Q  
X  
S  
Q

- : No Enclosure Panels Required
- : Wire Panels (Factory)
- : Wire Panels (Field)
- : Wire / Louvered Panels (Factory)
- : Wire / Louvered Panels (Field)
- : Louvered (Cond. Only) Panels (Factory)
- : Louvered (Cond. Only) Panels (Field)
- : Louvered (Full Unit) Panels (Factory)
- : Louvered (Full Unit) Panels (Field)
- : Special Enclosure Panels
- : No Sound Enclosure Required
- : Acoustical Arrgt. & Silencerb Kit
- : Compressor Blanket
- : Special Sound Enclosure
- : Dual Sound Attenuation
- : No Option Required
- : Special Quote
- : No Option Required
- : Special Quote
- : Standard Sound Fans
- : Low Sound Fans
- : High Static Fans
- : Special Sound Fans
- : No Final Overspray Paint Required
- : Final Overspray Paint
- : Special Overspray Paint Required
- X : No Vibration Isolators
- 1 : 1" Vibration Isolators
- S : Seismic Vibration Isolators
- N : Neoprene Vibration Isolators
- Q : Special Vibration Isolators

56 57 58 59 60 61

X  
1  
2  
5  
X  
A  
B  
C  
Q  
X  
Q  
X  
Q

- : No Refrigerant Warranty
- : 1 Year Refrigerant
- : 2 Year Refrigerant
- : 5 Year Refrigerant
- : No option required
- : Buy American Act
- : Both Buy American Act
- : Container Shipping Kit
- : Special quote
- : No option required
- : Special quote
- : No option required
- : Special quote
- : No option required
- : Special quote
- B : Basildon Plant
- R : Monterrey Plant

55 WARRANTY FIELD

- X : Standard Warranty
- B : 1st Year Parts & Labor
- C : 2nd Year Parts Only
- D : 2nd Year Parts & Labor
- E : 5 Year Compressor Parts Only
- F : 5 Year Compressor Parts & Labor Only
- G : 5 Year Units Parts Only
- H : 5 Year Unit Parts & Labor

NOTES:

1. Q :DENOTES SPECIAL / S.Q.
2. # :DENOTES STANDARD
3. X :w/in OPTIONS FIELD, DENOTES NO OPTION SELECTED
4. Agency Files (i.e. U.L. / E.T.L.; CE; ARI; ETC.) will contain info. based on the first 14 characters only.

## SECTION 3 - HANDLING AND STORAGE

### DELIVERY AND STORAGE

To ensure consistent quality and maximum reliability, all units are tested and inspected before leaving the factory. Standard units are shipped completely assembled and containing refrigerant under pressure. Units are shipped without export crating unless this has been specified on the Sales Order.

Units with remote evaporators will have the chiller and remote evaporator charged with nitrogen.

If the unit is to be put into storage, prior to installation, the following precautions should be observed:

- **Unit must be “blocked” so that the base is not permitted to sag or bow.**
- Ensure that all openings, such as water connections, are securely capped.
- Do not store where exposed to ambient air temperatures exceeding 110°F (43°C).
- The condensers should be covered to protect the fins from potential damage and corrosion, particularly where building work is in progress.
- The unit should be stored in a location where there is minimal activity in order to limit the risk of accidental physical damage.
- To prevent inadvertent operation of the pressure relief devices the unit must not be steam cleaned.
- It is recommended that the unit is periodically inspected during storage.

### INSPECTION

Remove any transit packing and inspect the unit to ensure that all components have been delivered and that no damage has occurred during transit. If any damage is evident, it should be noted on the carrier's freight bill and a claim entered in accordance with the instructions given on the advice note.

Major damage must be reported immediately to your local YORK representative.

### MOVING THE CHILLER

Prior to moving the unit, ensure that the installation site is suitable for installing the unit and is capable of supporting the weight of the unit and all associated services.

The units are designed to be lifted using cables. A spreader bar or frame 88" (2250 mm) wide should be used in order to prevent damage to the unit from the lifting chains (See Figures 3 and 4).

Units are provided with lifting eyes extending from the sides of the base frame which can be attached to directly using shackles or safety hooks (See Figure 4).

**The unit must only be lifted by the base frame at the points provided. Never move the unit on rollers, or lift the unit using a forklift truck.**

Care should be taken to avoid damaging the condenser cooling fins when moving the unit.

### Lifting Weights

For details of weights and weight distribution refer to the Technical Data Section.

### UNIT RIGGING

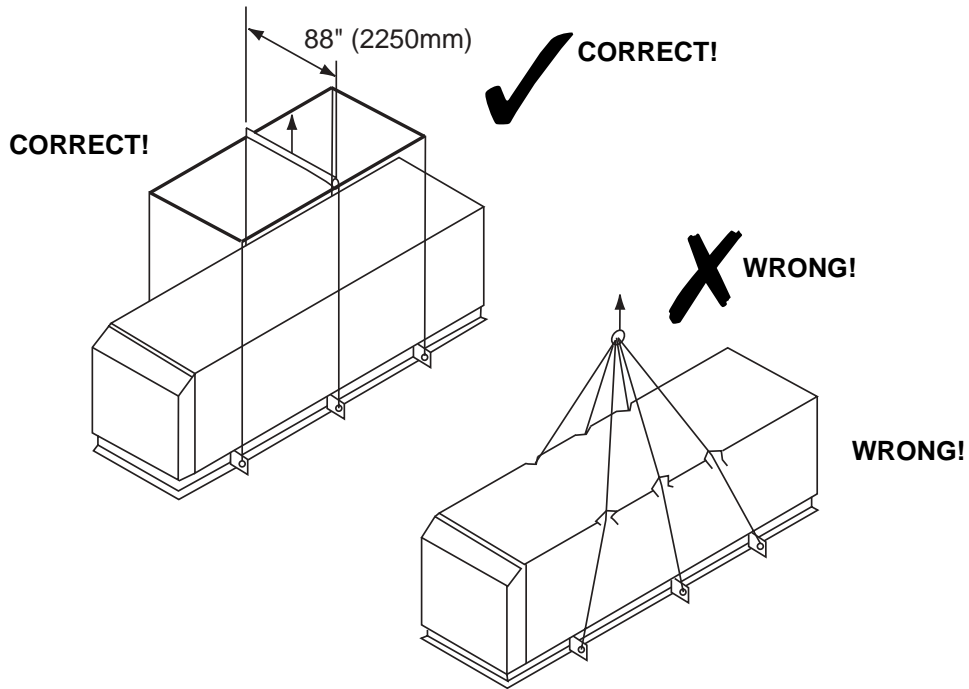

LD03514

FIG. 3 – UNIT RIGGING

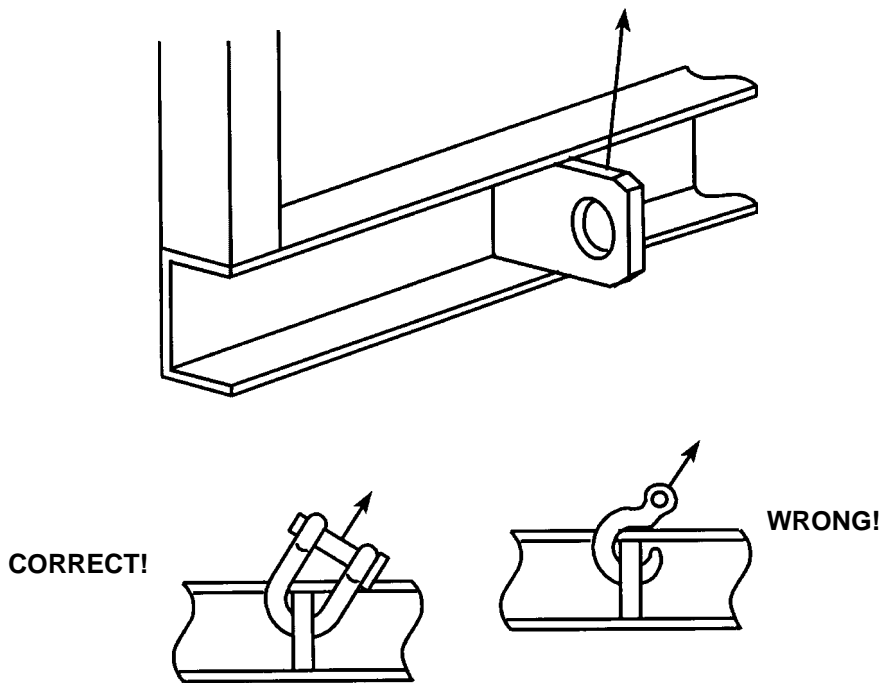

LD03515

FIG. 4 – LIFTING LUGS

## SECTION 4 - INSTALLATION

### LOCATION REQUIREMENTS

To achieve optimum performance and trouble-free service, it is essential that the proposed installation site meets with the location and space requirements for the model being installed. For dimensions, weight and space requirements, including service access, refer to the Technical Data Section.

It is important to ensure that the minimum service access space is maintained for cleaning and maintenance purposes.

### OUTDOOR INSTALLATIONS

The units can be installed at ground level, or on a suitable rooftop location. In both cases an adequate supply of air is required. Avoid locations where the sound output and air discharge from the unit may be objectionable.

The location should be selected for minimum sun exposure and away from boiler flues and other sources of airborne chemicals that could attack the condenser coils and steel parts of the unit.

If located in an area which is accessible to unauthorized persons, steps must be taken to prevent access to the unit by means of a protective fence. This will help to prevent the possibility of vandalism, accidental damage, or possible harm caused by unauthorized removal of protective guards or opening panels to expose rotating or high voltage components.

For ground level locations, the unit must be installed on a suitable flat and level concrete base that extends to fully support the two side channels of the unit base frame. A one-piece concrete slab, with footings extending below the frost line is recommended. To avoid noise and vibration transmission the unit should not be secured to the building foundation.

On rooftop locations, choose a place with adequate structural strength to safely support the entire operating weight of the unit and service personnel. The unit can be mounted on a concrete slab, similar to ground floor locations, or on steel channels of suitable strength. The channels should be spaced at the same centres as the vibration mounting holes in the unit base frame and must be at least 4-3/4" (120 mm) wide at the contact points. This will allow vibration isolators to be fitted if required.

Any ductwork or attenuators fitted to the unit must not have a total static pressure resistance, at full unit airflow, exceeding the capability of the fans installed in the unit.

### INDOOR INSTALLATIONS

The unit can be installed in an enclosed plant room providing the floor is level and of suitable strength to support the full operating weight of the unit. It is essential that there is adequate clearance for airflow to the unit. The discharge air from the top of the unit must be ducted away to prevent recirculation of air within the plant room. If common ducts are used for fans, non-return dampers must be fitted to the outlet from each fan.

The discharge ducting must be properly sized with a total static pressure loss, together with any intake static pressure loss, less than the available static pressure capability for the type of fan fitted.

The discharge air duct usually rejects outside the building through a louver. The outlet must be positioned to prevent the air being drawn directly back into the air intake for the condenser coils, as such recirculation will affect unit performance.

### LOCATION CLEARANCES

Adequate clearances around the unit(s) are required for the unrestricted airflow for the air-cooled condenser coils and to prevent recirculation of warm discharge air back onto the coils. If clearances given are not maintained, airflow restriction or recirculation will cause a loss of unit performance, an increase in power consumption and may cause the unit to malfunction. Consideration should also be given to the possibility of down drafts, caused by adjacent buildings, which may cause recirculation or uneven unit airflow.

For locations where significant cross winds are expected, such as exposed roof tops, an enclosure of solid or louver type is recommended to prevent wind turbulence interfering with the unit airflow.

When units are installed in an enclosure, the enclosure height should not exceed the height of the unit on more than one side. If the enclosure is of louvered construction the same requirement of static pressure loss applies as for ducts and attenuators stated above.

Where accumulation of snow is likely, additional height must be provided under the unit to ensure normal airflow to the unit.



***The clearance dimensions given are necessary to maintain good airflow and ensure correct unit operation. It is also necessary to consider access requirements for safe operation and maintenance of the unit and power and control panels. Local health and safety regulations, or practical considerations for service replacement of large components, may require larger clearances than those given in the Technical Data Section of this manual, (page 102).***

**COMPRESSOR FEET BOLT REMOVAL**

After the chiller is placed in the final location, remove the four bolts, 1, attaching the compressor feet to the frame rails. These bolts are only used for shipping purposes. The bolts are screwed into the compressor feet from the bottom side of the frame rail. Refer to Figure 5.

After the four shipping bolts are removed from the compressor feet, the compressor will be held in place by the four corner brackets, 2.

This assembly reduces compressor noise by isolating the compressor from the base rails.

DO NOT remove the four 3/8" bolts, 3, mounting the corner brackets, 2, to the frame rails.

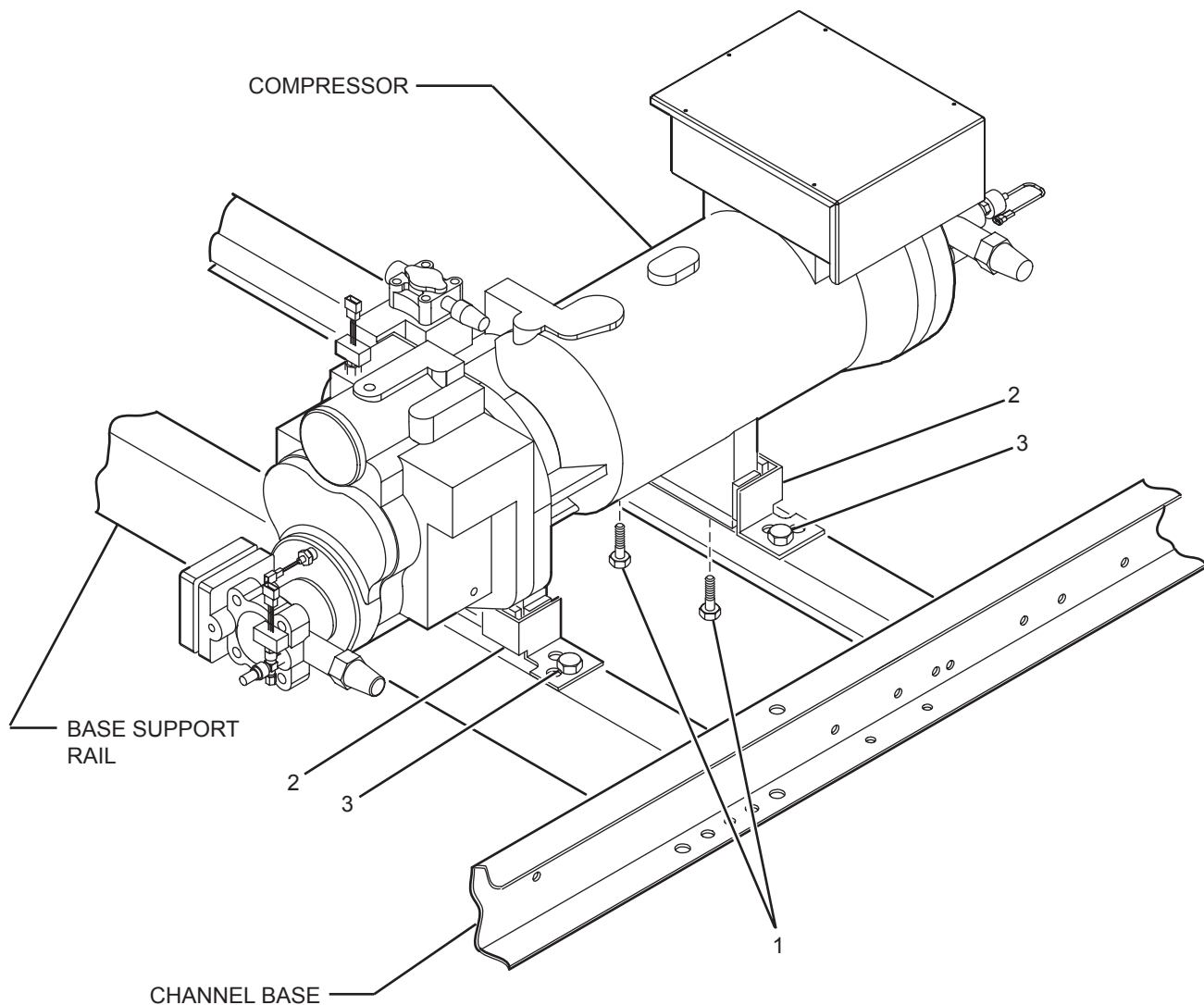

LD09131

**FIG. 5 – COMPRESSOR MOUNTING**

## VIBRATION ISOLATORS

Optional sets of vibration isolators can be supplied loose with each unit.

Using the Isolator tables, refer to the *Technical Data Section*, identify each mount and its correct location on the unit.

### Installation

Place each mount in its correct position and lower the unit carefully onto the mounts ensuring the mount engages in the mounting holes in the unit base frame.

On adjustable mounts, transfer the unit weight evenly to the springs by turning the mount adjusting nuts (located just below the top plate of the mount) counter-clockwise to raise and clockwise to lower. This should be done two turns at a time until the top plates of all mounts are between 1/4" and 1/2" (6 and 12 mm) clear of top of their housing and the unit base is level.

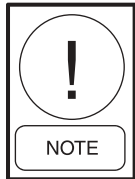

***A more detailed installation instruction is provided in the Installation Instructions for VMC Series AWR/AWMR and CP Restrained Mountings Section of this manual, (page 119).***

## SHIPPING BRACES

The chiller's modular design does not require shipping braces.

## PIPEWORK CONNECTION

### General Requirements

The following piping recommendations are intended to ensure satisfactory operation of the unit(s). Failure to follow these recommendations could cause damage to the unit, or loss of performance, and may invalidate the warranty.



***The maximum flow rate and pressure drop for the evaporator must not be exceeded at any time. Refer to the Technical Data Section for details.***

***The liquid must enter the evaporator at the inlet connection. The inlet connection for the evaporator is at the control panel end of the unit when viewed from the power and control panels.***

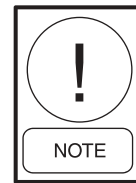

***The water inlet is always at the end of the evaporator where the liquid refrigerant enters and the suction gas leaves.***

**A flow switch must be installed in the customer pipework at the outlet of the evaporator and wired back to the control panel using shielded cable.** There should be a straight run of piping of at least 5 pipe diameters on either side. The flow switch should be wired to Terminals 13 and 14 (see Figs. 13 and 14, pages 38 and 39). A flow switch is required prevent damage to the evaporator caused by the unit operating without adequate liquid flow.

The flow switch used must have gold plated contacts for low voltage/current operation. Paddle type flow switches suitable for 150 PSIG (10 bar) (optional 300 PSIG) working pressure and having a 1" N.P.T. connection can be obtained from YORK as an accessory for the unit. Alternatively a differential pressure switch sited across an orifice plate may be used, preferably of the high/low limit type.

The chilled liquid pump(s) installed in the pipework system(s) should discharge directly into the unit evaporator section of the system. The pump(s) may be controlled external to the unit - but an override must be wired to the control panel so that the unit can start the pump in the event that the liquid temperature falls below the minimum setting. For details refer to "Electrical Connection."

Pipework and fittings must be separately supported to prevent any loading on the evaporator. Flexible connections are recommended which will also minimize transmission of vibrations to the building. Flexible connections must be used if the unit is mounted on anti-vibration mounts as some movement of the unit can be expected in normal operation.

Pipework and fittings immediately next to the evaporator should be readily de-mountable to enable cleaning before operation, and to facilitate visual inspection of the exchanger nozzles.

**The evaporator must be protected by a strainer, preferably of 30 mesh, fitted as close as possible to the liquid inlet connection, and provided with a means of local isolation.**

The evaporator must not be exposed to flushing velocities or debris released during flushing. It is recommended that a suitably sized by-pass and valve arrangement is installed to allow flushing of the pipework system. The by-pass can be used during maintenance to isolate the heat exchanger without disrupting flow to other units.

Thermometer and pressure gauge connections should be provided on the inlet and outlet connections of each evaporator.

Drain and air vent connections should be provided at all low and high points in the pipework to permit drainage of the system and to vent any air in the pipes.

Liquid systems at risk of freezing, due to low ambient temperatures, should be protected using insulation and heater tape and/or a suitable glycol solution. The liquid pump(s) must also be used to ensure liquid is circulated when the ambient temperature approaches freezing point. Insulation should also be installed around the evaporator nozzles. Heater tape of 21 watts per meter under the insulation is recommended, supplied independently and controlled by an ambient temperature thermostat set to switch on at 37°F (21°C) above the freezing temperature of the liquid.

The liquid circulation pump must be controlled by the unit. This will ensure that when the liquid temperature falls within 3° or 5°F (2° or 3°C) of freezing, the pump will start.

The evaporator is protected by heater mats under the insulation which are supplied from the unit control system power supply. During risk of freezing the control system should be powered on to provide the freeze protection function unless the liquid systems have been drained.



***Any debris left in the water pipework between the strainer and evaporator could cause serious damage to the tubes in the evaporator and must be avoided. The installer/user must also ensure that the quality of the water in circulation is adequate, without any dissolved gases which can cause oxidation of steel parts within the evaporator.***

**WATER TREATMENT**

The unit performance given in the Design Guide is based on a fouling factor of 0.00025 ft<sup>2</sup>hr°F/Btu (0.044m<sup>2</sup>/hr °C/kW). Dirt, scale, grease and certain types of water treatment will adversely affect the heat exchanger surfaces and therefore unit performance. Foreign matter in the water system(s) can increase the heat exchanger pressure drop, reducing the flow rate and causing potential damage to the heat exchanger tubes.

Aerated, brackish or salt water is not recommended for use in the water system(s). YORK recommends that a water treatment specialist is consulted to determine the proposed water composition will not affect the evaporator materials of carbon steel and copper. The pH value of the water flowing through the evaporator must be kept between 7 and 8.5.

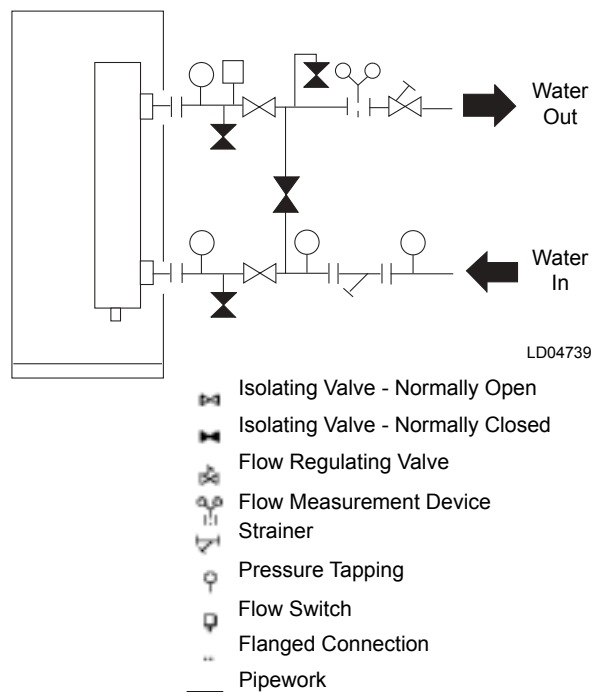

**FIG. 6 – PIPEWORK ARRANGEMENT**

## PIPEWORK ARRANGEMENT

Fig. 6 shows the following is a suggested pipework arrangement for single unit installations. For multiple unit installations, each unit should be piped as shown.

## CONNECTION TYPES & SIZES

For connection sizes relevant to individual models refer to the Technical Data Section.

## EVAPORATOR CONNECTIONS

Standard chilled liquid connections on all evaporators are of the Victaulic Groove type.

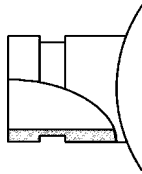

LD03521

**FIG. 7 – VICTAULIC GROOVE**

### Option Flanges

One of two types of flanges may be fitted depending on the customer or local Pressure Vessel Code requirements. These are Victaulic-Adapter flanges, normally supplied loose, or weld flanges which may be supplied loose or ready fitted. Victaulic-Adapter and weld flange dimensions are to ISO 7005 - NP10.

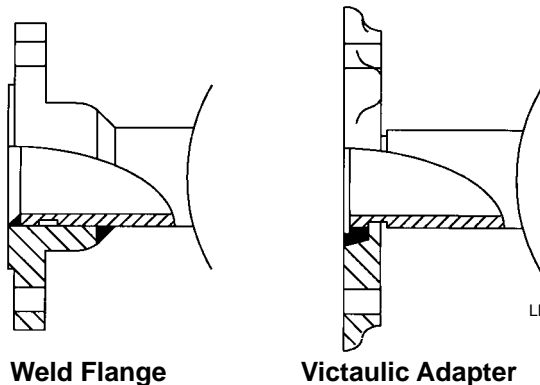

LD03523

**Weld Flange**

**Victaulic Adapter**

**FIG. 8 – FLANGE ATTACHMENTS**

## REFRIGERANT RELIEF VALVE PIPING

Evaporators and oil separators are each protected against internal refrigerant overpressure by refrigerant relief valves. For evaporators, a pressure relief valve is mounted on each of the main refrigerant lines connecting the evaporator to the compressors.

It is recommended that a piece of pipe is fitted to each valve and directed so that if the valve is activated, the release of high pressure gas and liquid cannot be a danger or cause injury. For indoor installations pressure relief valves should be piped to the exterior of the building.

The size of any pipework attached to a relief valve must be of sufficient diameter so as not to cause resistance to the operation of the valve. Unless otherwise specified by local regulations, internal diameter depends on the length of pipe required and is given by the following formula:

$$D^5 = 1.447 \times L$$

Where:

D = minimum pipe internal diameter in cm

L = length of pipe in meters

If relief pipework is common to more than one valve its cross sectional area must be at least the total required by each valve. Valve types should not be mixed on a common pipe. Precautions should be taken to ensure that the outlet of relief valves/vent pipe remain clear of obstructions at all times.

## DUCTWORK CONNECTION

### General Requirements

The following ductwork recommendations are intended to ensure satisfactory operation of the unit. Failure to follow these recommendations could cause damage to the unit, or loss of performance, and may invalidate the warranty.

When ducting is to be fitted to the fan discharge it is recommended that the duct should be the same cross sectional area as the fan outlet and straight for at least three feet (1 meter) to obtain static regain from the fan.

Ductwork should be suspended with flexible hangers to prevent noise and vibration being transmitted to the structure. A flexible joint is also recommended between the duct attached to the fan and the next section for the same reason. Flexible connectors should not be allowed to concertina.

The unit is not designed to take structural loading. No significant amount of weight should be allowed to rest on the fan outlet flange, deck assemblies or condenser coil module. No more than 3 feet (1 meter) of light construction ductwork should be supported by the unit. Where cross winds may occur, any ductwork must be supported to prevent side loading on the unit.

If the ducts from two or more fans are to be combined into a common duct, back-flow dampers should be fitted in the individual fan ducts. This will prevent recirculation of air when only one of the fans is running.

Units are supplied with outlet guards for safety and to prevent damage to the fan blades. If these guards are removed to fit ductwork, adequate alternative precautions must be taken to ensure persons cannot be harmed or put at risk from rotating fan blades.

**ELECTRICAL CONNECTION**

The following connection recommendations are intended to ensure safe and satisfactory operation of the unit. Failure to follow these recommendations could cause harm to persons, or damage to the unit, and may invalidate the warranty.



***No additional controls (relays, etc.) should be mounted in the control panel. Power and control wiring not connected to the control panel should not be run through the control panel. If these precautions are not followed it could lead to a risk of electrocution. In addition, electrical noise could cause malfunctions or damage the unit and its controls.***



***After connection do not switch on main power to the unit. Some internal components are live when main power is switched on and this must only be done by Authorized persons.***

**POWER WIRING**

All electrical wiring should be carried out in accordance with local regulations. Route properly sized cables to cable entries on both sides of the unit.

In accordance with U.L. Standard it is the responsibility of the user to install overcurrent protection devices between the supply conductors and the power supply terminals on the unit.

To ensure that no eddy currents are set up in the power panel, the cables forming each 3-phase power supply must enter via the same cable entry.



***All sources of supply to the unit must be taken via a common point of isolation (not supplied by YORK).***

**STANDARD UNITS WITH MULTI POINT POWER SUPPLY WIRING**

Standard units require two 3-phase separately fused 3-wire supplies plus a ground per refrigerant system. One supply to be connected to each of the power panels.

Connect each of the main 3-phase supplies to the circuit breakers, non-fused disconnect switches or terminal boards located in the power panels using lug sizes detailed in the Technical Data Section.

Connect the ground wires to the main protective ground terminals in each power panel.

**Units with Single-Point Power Supply Wiring**

Units require only one 3-phase supply plus ground.

Connect the 3-phase supplies to the terminal block or non-fused disconnect switch/ circuit breaker located in the options panel using lug sizes detailed in the Technical Data Section.

Connect a ground wire to the main protective ground terminal.

**115VAC CONTROL SUPPLY TRANSFORMER**

A 3-wire high voltage to 115VAC supply transformer is standard in the chiller. This transformer steps down the high voltage supply to 115VAC to be used by the Micro Panel, Power Panel components, solenoids, heaters, etc.

The high voltage for the transformer primary is taken from the chiller input to one of the systems. Fusing is provided for the transformer.

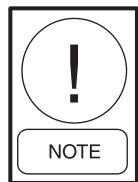

***It is important to check that the correct primary tapping has been used and that it conforms to the site high voltage supply.***



***Removing high voltage power to the chiller will remove the 115VAC supply voltage to the microprocessor circuitry and the evaporator heater. In cold weather, this could cause serious damage to the chiller due to evaporator freeze-up. Do not remove power unless alternate means are taken to assure operation of the evaporator heater.***

### **Remote Emergency Stop Device**

If required, a remote emergency stop device can be wired into the unit. The device should be wired into terminals 31 and 32 (Figs. 13 and 14, pages 38 and 39) in the microprocessor control panel.

### **CONTROL PANEL WIRING**

All wiring to the control panel terminal block terminals 13-19 is nominal 30VDC and must be run in shielded cable, with the shield grounded at the panel end only. Run shielded cable separately from mains cables to avoid electrical noise pick-up. Use the control panel cable entry to avoid the power cables.

The voltage free contacts must be suitable for 30VDC (gold contacts recommended). If the voltage free contacts are from a relay or contactor, the coil of the device must be suppressed using a standard R/C suppressor. The above precautions must be taken to avoid electrical noise which could cause a malfunction or damage to the unit and its controls.

The length of cable to these terminals must not exceed 25 ft. (7.5 m) unless an isolator is fitted.

### **VOLTS FREE CONTACTS**

#### **Chilled Liquid Pump Starter**

Terminals 25 and 26 (Figs. 13 and 14, pages 38 and 39) close to start the chilled liquid pump. This contact can be used as a master start/stop for the pump in conjunction with the daily start/stop schedule. See Section 8.1.15.

#### **Run Contact**

Terminals 29 and 30 (Figs. 13 and 14, pages 38 and 39) close to indicate that a system is running.

### **Alarm Contacts**

Each system has a voltage-free change over contact which will operate to signal an alarm condition whenever a system locks out, or there is a power failure. To obtain system alarm signal, connect the alarm circuit to volt free terminals 23 and 24 (Figs. 13 and 14, pages 38 and 39) for No. 1 System, terminals 27 and 28 for No. 2 System, terminals 37 and 38 for No. 3 System and terminals 41 and 42 for No. 4 System.

### **SYSTEM INPUTS**

#### **Flow Switch**

A chilled water flow switch, (either by YORK or others) **MUST** be installed in the leaving water piping of the evaporator. There should be a straight horizontal run of at least 5 diameters on each side of the switch. Adjust the flow switch paddle to the minimum flow allowed through the evaporator. (See manufacturer's instructions furnished with the switch.) The switch is to be wired to terminals 13 - 14 of CTB1 located in the control panel, as shown on the unit wiring diagram.

#### **Remote Run / Stop**

Connect remote switch(es) in series with the flow switch to provide remote run/stop control if required.

#### **Remote Print**

Closure of suitable contacts connected to terminals 13 and 18 (Figs. 13 and 14, pages 38 and 39) will cause a hard copy printout of Operating Data/Fault History to be made if an optional printer is connected to the RS 232 port.

#### **Remote Setpoint Offset – Temperature**

Timed closure of suitable contacts connected to terminals 13 and 17 (PWM contacts) will provide remote offset function of the chilled liquid set point if required. See Figs. 13 and 14, pages 38 and 39 for contact location.

#### **Remote Setpoint Offset – Current**

Timed contact closure of a suitable contact connected to terminals 13 and 16 (PWM contacts) will provide remote offset of EMS% CURRENT LOAD LIMIT. See Figs. 13 and 14, pages 38 and 39 for contact location.

## POWER PANEL LAYOUTS (TYPICAL) (WYE-DELTA - TYPICAL)

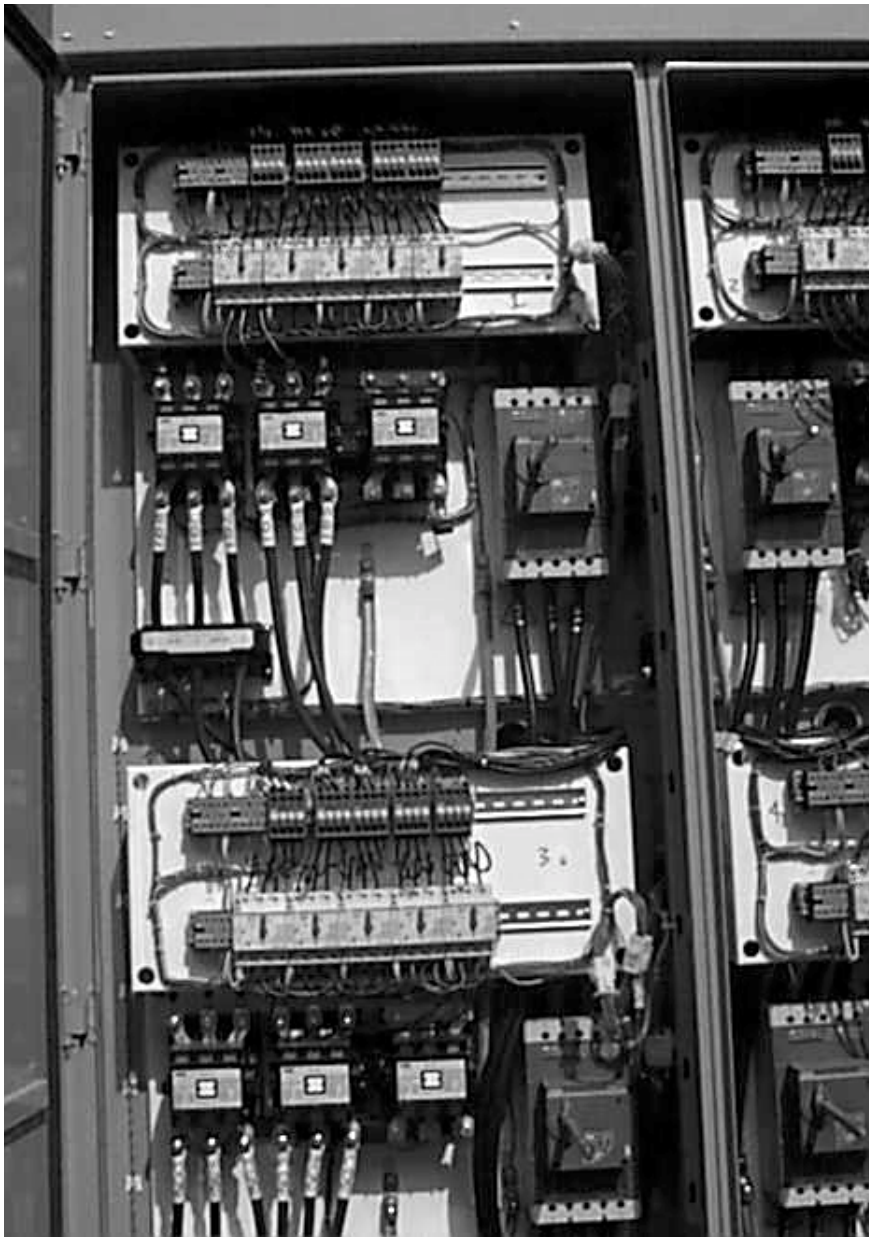

00263VIP

FIG. 9 – POWER PANEL SECTION

## OPTION PANEL LAYOUT (TYPICAL)

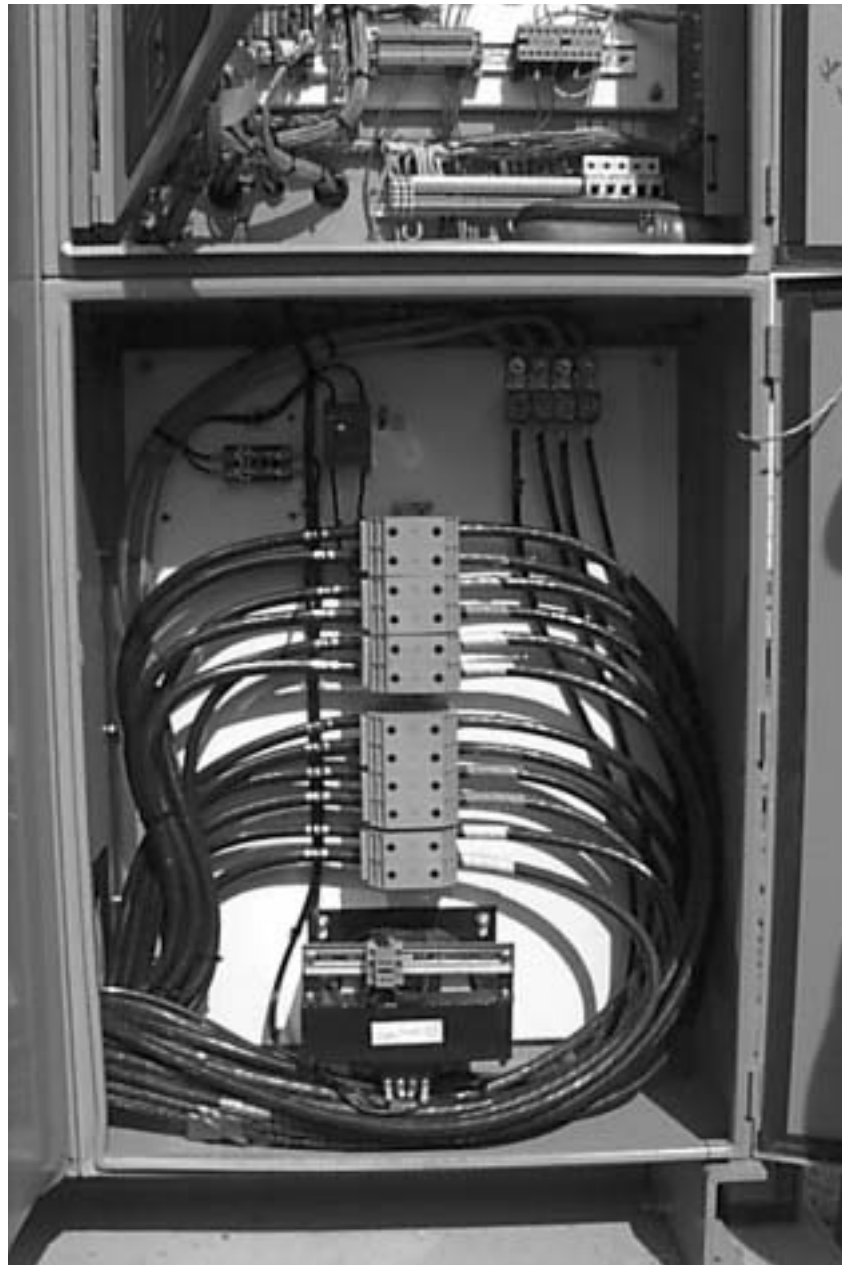

00246VIP

4

**FIG. 10** – OPTION PANEL SECTION

## LOGIC SECTION LAYOUT

50 Hz Models:

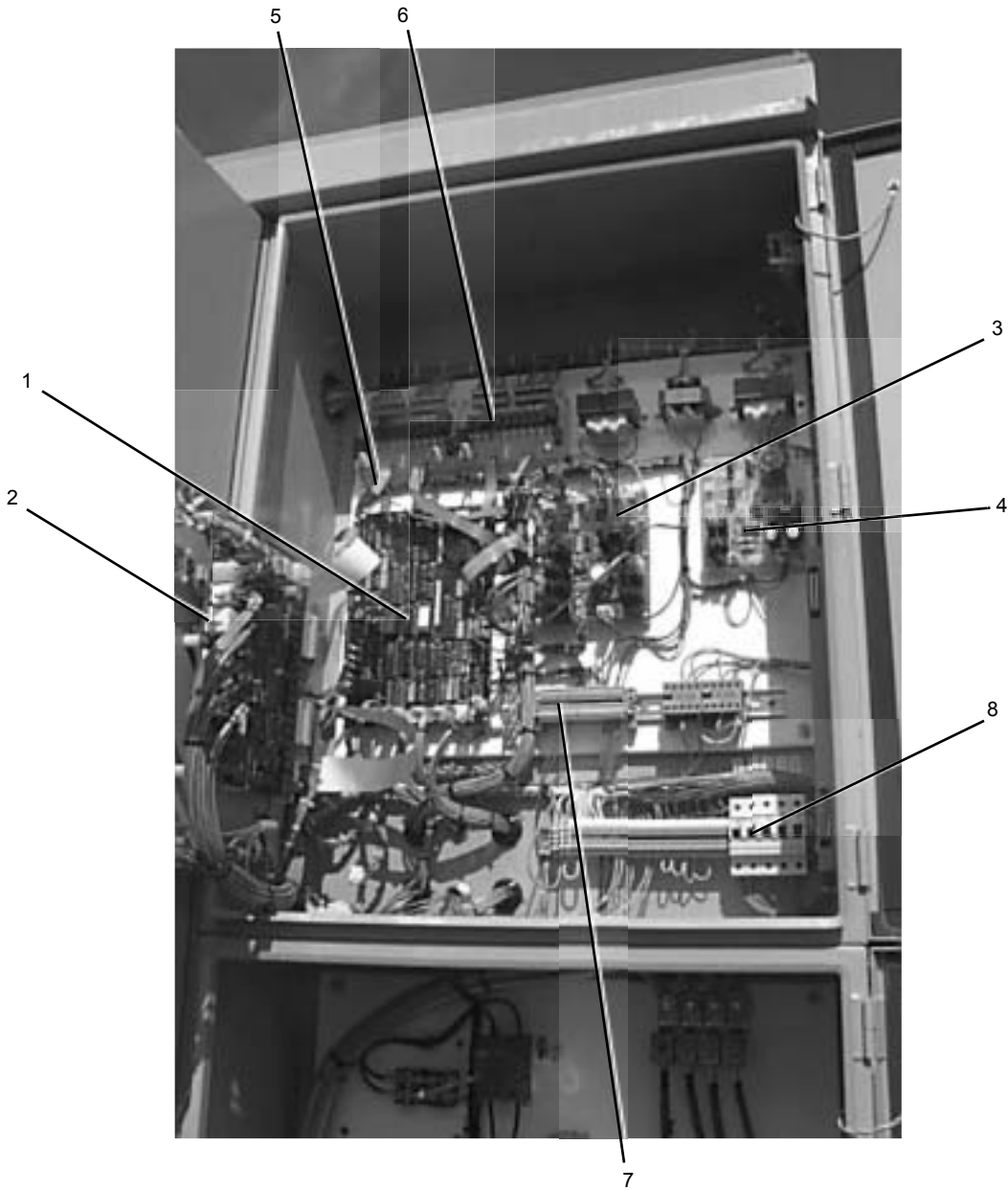

**PHOTOGRAPH OF  
50 HZ MODEL LOGIC SECTION**

ITEM	DESCRIPTION
1	Microprocessor Board
2	I/O Board #2
3	I/O Expansion Board #1
4	Power Supply Board
5	Relay Output Board #1
6	Relay Output Board #2
7	Flow Switch & Customer Connection Terminals
8	Circuit Breakers CB1 - CB5

00247VIP

**FIG. 11 – LOGIC SECTION LAYOUT**

# LOGIC SECTION LAYOUT WITH CONTROL PANEL



4

00248VIP

FIG. 12 – LOGIC SECTION LAYOUT WITH CONTROL PANEL

# CUSTOMER CONNECTIONS

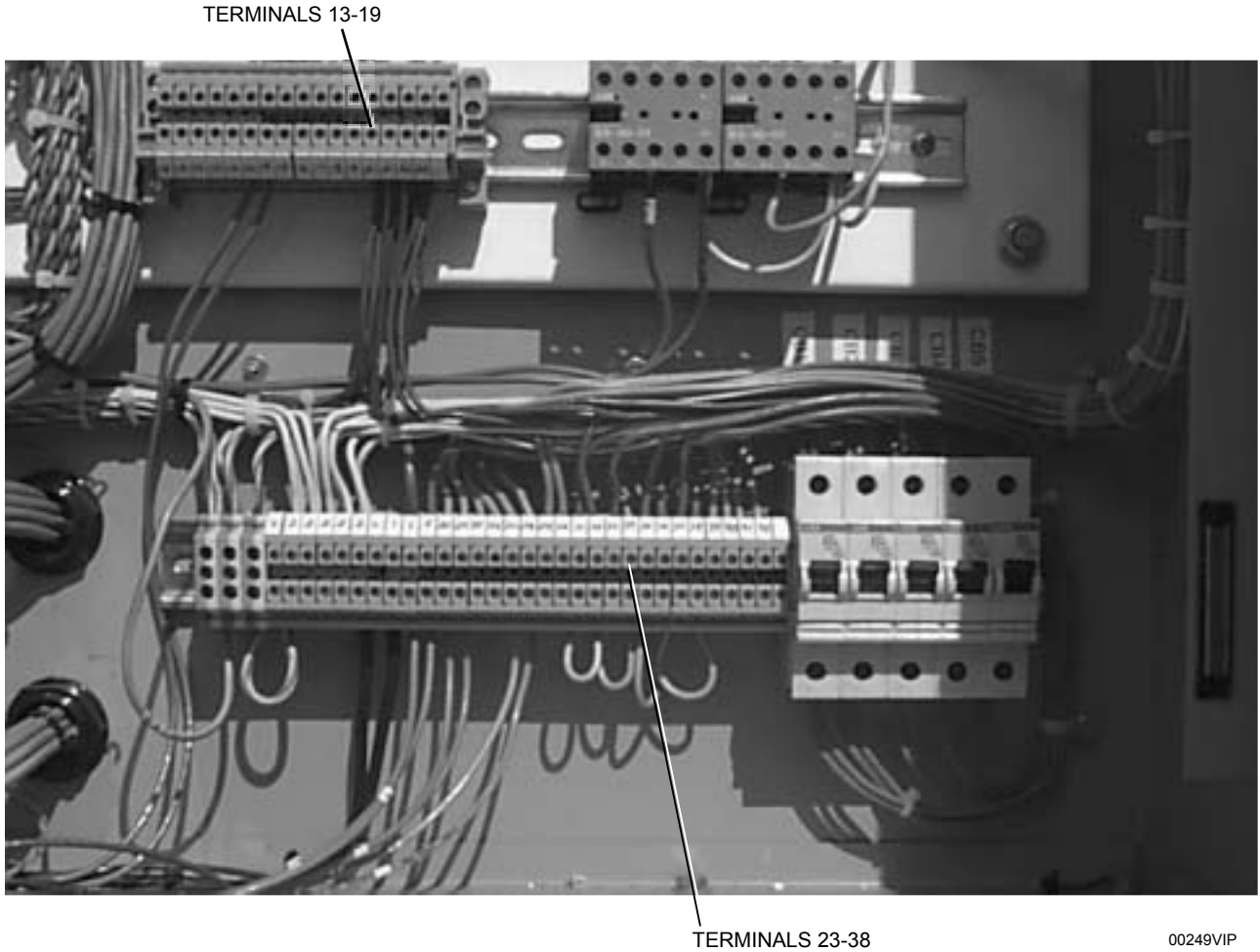

00249VIP

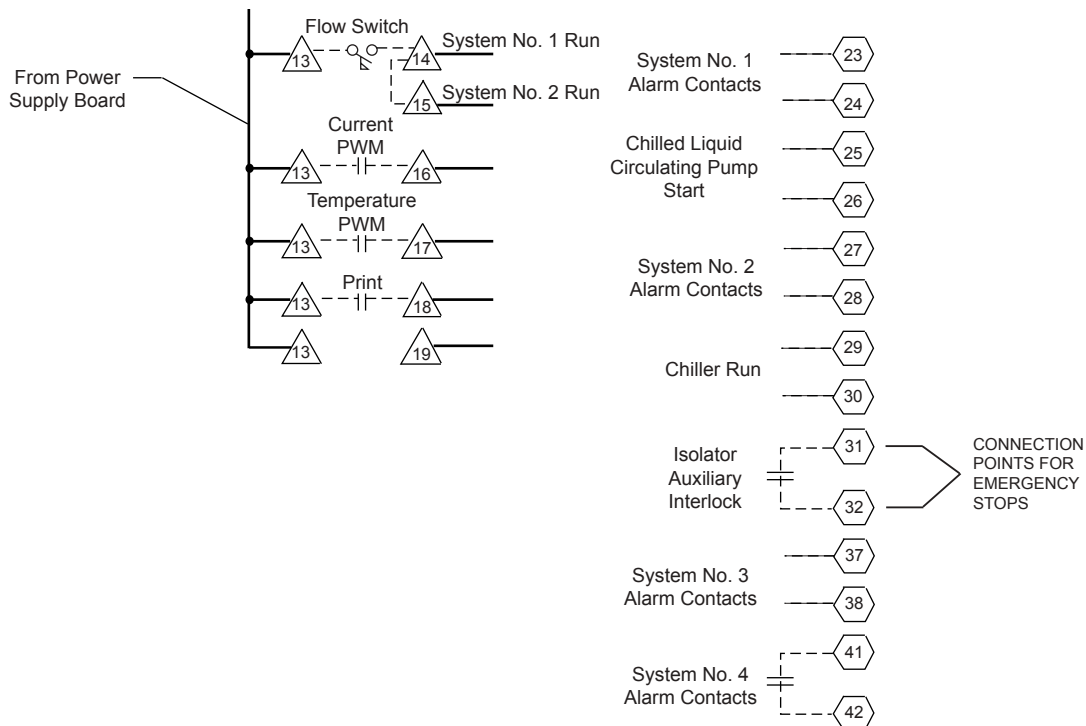
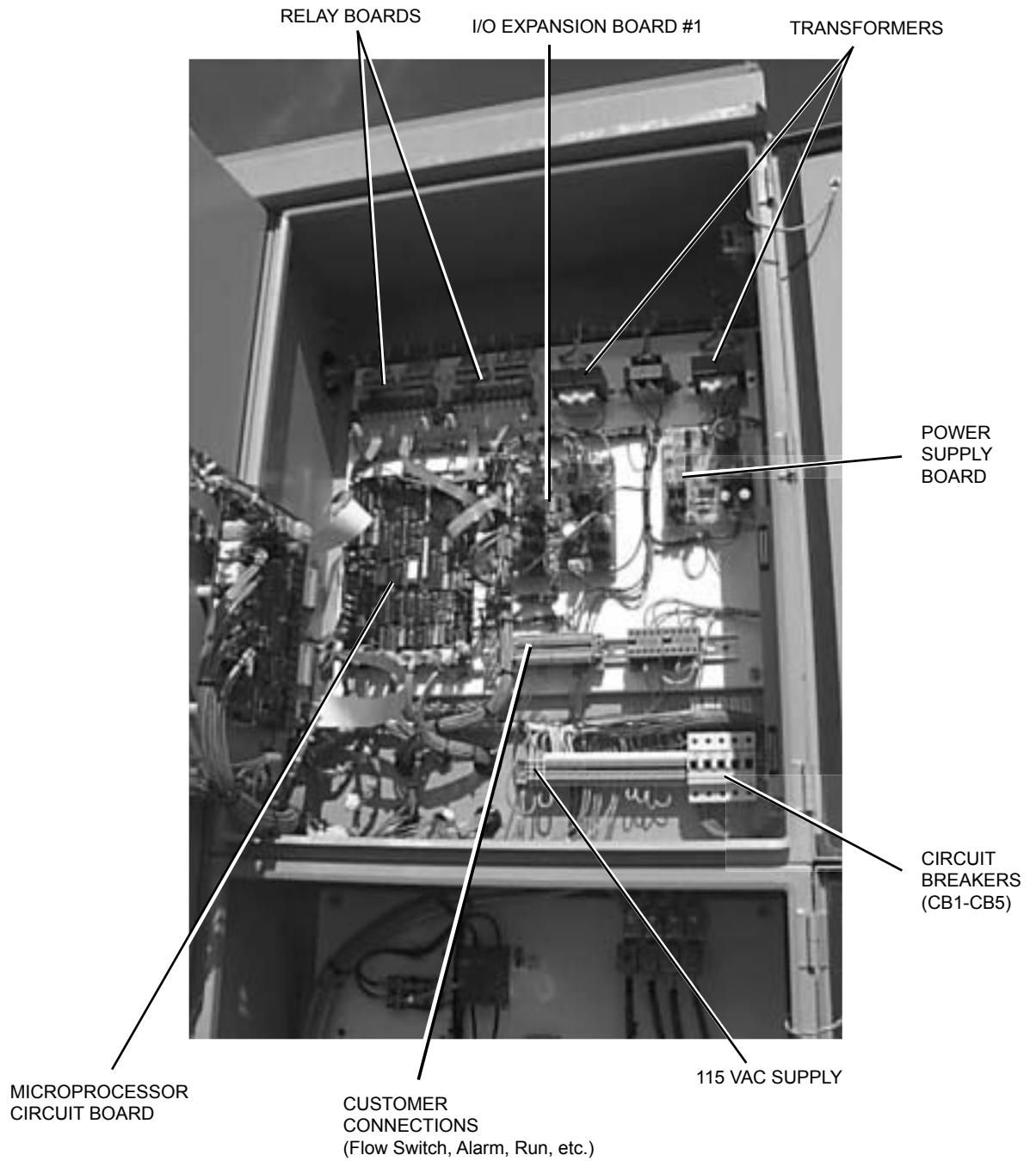

FIG. 13 – CUSTOMER CONNECTIONS

LD09410

# CUSTOMER CONNECTIONS



4

**FIG. 14 – CUSTOMER CONNECTIONS**

## SECTION 5 - COMMISSIONING

### PREPARATION



*Commissioning of this unit should only be carried out by YORK Authorized personnel.*

**The Millennium Microcomputer Control System Operating Instructions must be read in conjunction with this section.**

### PREPARATION – POWER OFF

The following checks should be made with the customer supply/supplies to the unit switched OFF.

#### Inspection

Inspect unit for installation damage. If damage is found take action and/or repair as appropriate.

#### Refrigerant Charge

Units are normally shipped as standard with a full refrigerant operating charge. Check that refrigerant pressure is present in both systems and that no leaks are apparent. If no pressure is present a leak test must be undertaken. The leak(s) should be located and repaired. Repaired systems and units supplied with a nitrogen holding charge must be evacuated with a suitable vacuum pump/recovery unit as appropriate to below 100 microns.

Do not liquid charge with static water in the evaporator. Care must also be taken to liquid charge slowly to avoid excessive thermal stress at the charging point. Once the vacuum is broken, charge into the condenser coils with the full operating charge as given in the Technical Data Section.

#### Valves

Open each compressor suction, economizer, and discharge valve fully (counter-clockwise) then close one turn of the stem to ensure operating pressure is fed to the pressure transducers. Open the liquid line service valve fully and ensure the oil return line ball valve is open in each system.

#### Compressor Oil

To add oil to a circuit - connect a YORK hand oil pump (Part No. 470-10654-000) to the 1/4" oil charging valve on the oil separator piping with a length of clean hose

or copper line, but do not tighten the flare nut. Using clean oil of the correct type ("L" oil), pump oil until all air has been purged from the hose then tighten the nut. Stroke the oil pump to add oil to the oil system. The oil level should be between the middle of the lower and middle of the upper sight glasses of the oil separator. Approximately 5 gallons is present in the entire chiller system, with 1-2 gallons in the oil separator.

#### Fans

Check that all fans are free to rotate and are not damaged. Ensure blades are at the same height when rotated. Ensure fan guard is securely fixed.

#### Isolation/Protection

Verify that all sources of electrical supply to the unit are taken from a single point of isolation. Check that the maximum recommended fuse sizes given in the Technical Data Section have not been exceeded.

#### Control Panel

Check the panel to see that it is free of foreign materials (wire, metal chips, etc.) and clean out if required.

#### Power Connections

Check to assure the customer power cables are connected correctly. Ensure that connections of power cables within the panels to the circuit breakers, terminal blocks or switch disconnectors are tight.

#### Grounding

Verify that the unit's protective terminal(s) are properly connected to a suitable grounding point. Ensure that all unit internal ground connections are tight.

#### Overloads

Ensure that the fan overloads settings are correct for the type of fan fitted.

#### Supply Voltage

Verify that the site voltage supply corresponds to the unit requirement and is within the limits given in the Technical Data Section.

#### Control Transformer

The 3-wire control transformer is mounted in the options panel. It is important to check that the correct primary tapping has been used:

With the supply voltage to the unit turned off, remove the lid to the transformer box.

Check that the tapping used conforms to the site supply voltage. After the tapping is verified, replace the lid.

### Switch Settings

Ensure that the unit ON/OFF switch on the display door and the micro board system switches S2 through S5 are set to “0” (OFF). Set the red handled emergency stop device on the options panel to “1” (ON). For units fitted with door interlocked circuit breakers the power panel doors must be closed and the devices set to “1” (ON). The customer’s power disconnection devices can now be set to ON.



*The machine is now live!*

The unit is fitted with an under voltage circuit in each panel and it may take between 5 to 10 seconds for its contacts to close and energize the unit’s electronics, including the display on the main panel.

### Compressor Heaters

Verify the compressor heaters are energized. If the ambient temperature is above 96°F (36°C) the compressor heaters must be on for at least 8 hours before start-up to ensure all refrigerant liquid is driven out of the compressor. If the ambient temperature is below 86°F (30°C) then allow 24 hours.

### Water System

Verify that the chilled liquid system has been installed correctly, and has been commissioned with the correct direction of water flow through the evaporator. The inlet should be at the refrigerant pipework connection end of the evaporator. Purge air from the top of the evaporator using the plugged air vent mounted on the top of the evaporator body. Flow rates and pressure drops must be within the limits given in the Technical Data Section. Operation outside of these limits is undesirable and could cause damage.

### Flow Switch

Verify a chilled water flow switch is correctly fitted in the customer’s pipework on the evaporator outlet, and wired into the control panel correctly using shielded

cable. There should be a straight run of at least 5 pipe diameters on either side of the flow switch. The flow switch should be connected to terminals 13 and 14 in the micro panel (Figs. 13 and 14, pages 38 and 39).

### Temperature sensor(s)

Ensure the leaving liquid temperature sensor is coated with heat conductive compound (part no. 013-00890-000) and is inserted in the water outlet sensor pocket of the evaporator. This sensor also acts as the freeze protection thermostat sensor and must always be in the water OUTLET sensor pocket.

### Control Supply

Verify the control panel display is illuminated.

### Programmed Options

Verify that the options factory programmed into the Microcomputer Control Center are in accordance with the customer’s order requirements by pressing the ‘Options’ key on the keypad and reading the settings from the display.

### Programmed Settings

Ensure the system cut-out and operational settings are in accordance with the instructions provided in Section 8 (page 178) and with the general chiller operational requirements by pressing the ‘Program’ key. The chilled liquid temperature control settings need to be set according to the unit model and required operating conditions.

### Date and Time

Program the date and time by first ensuring that the CLK jumper J18 on the microprocessor board is in the ON position (top two pins). Then press the ‘Clock Set Time’ key and set the date and time. (See Section 7.)

### Start/Stop Schedule

Program the daily and holiday start/stop by pressing the ‘Set Schedule/Holiday’ key. (See Section 7.)

### Setpoint and Remote Offset

Set the required leaving chilled liquid temperature setpoint and control range. If remote temperature reset (offset) is to be used, the maximum reset must be programmed by pressing the ‘Remote Reset Temp’ key. (See Section 6.)

**FIRST TIME START-UP**

*During the commissioning period there should be sufficient heat load to run the unit under stable full load operation to enable the unit controls, and system operation to be set up correctly and a commissioning log taken. Be sure that the Micro Panel is properly programmed (page 178) and the System Start-up Checklist (page 130) is completed.*

**Interlocks**

Verify that liquid is flowing through the evaporator and that heat load is present. Ensure that any remote run interlocks are in the run position and that the run schedule requires the unit to run or is overridden.

**System Switches**

Place the 'SYS 1' switch on the microprocessor board to the 'ON' position – (Fig. 73, page 142).

**Start-up**

Remove the locking device from the unit Auto/OFF switch which prevents unauthorized starting of the unit before commissioning. Press the 'Status' key, then turn the unit switch to the "1" position to start the unit (there may be a few seconds delay before the first compressor starts because of the anti-recycle timer). Be ready when each compressor starts, to switch the unit OFF immediately if any unusual noises or other adverse conditions develop. Use the appropriate emergency stop device if necessary.

**Oil Pressure**

When a compressor starts, press the relevant 'System Pressures' key and verify that oil differential pressure develops immediately (Discharge Pressure minus Section Pressure). If oil pressure does not develop, the automatic controls will shut down the compressor. Under no circumstances should a restart attempt be made on a compressor which does not develop oil pressure immediately. Switch the unit switch to the '0' position (OFF).

**Refrigerant Flow**

When a compressor starts a flow of liquid refrigerant will be seen in the liquid line sight glass. After several minutes operation and providing a full charge of refrigerant is in the system, the bubbles will disappear and be replaced by a solid column of liquid.

**Fan Rotation**

As discharge pressure rises, the condenser fans operate in stages to control the pressure. Verify that the fan operation is correct for the type of unit.

**Suction Superheat**

Check suction superheat at steady full compressor load only. Measure suction temperature on the copper line about 6" (150 mm) before the compressor suction service valve. Measure suction pressure at the compressor service valve. Superheat should be 10°F to 12°F (5.6°C to 6.7°C).

**Expansion Valve**

The electronic expansion valves are factory set and should not need adjustment.

**Economizer Superheat**

**(Not all models are equipped with economizers)**

Check economizer superheat at steady full compressor load only, under conditions when the economizer solenoid is energized. (See Section 1.23, page 146) Measure gas temperature on the economizer outlet pipe next to the expansion valve bulb. Measure gas pressure at the back seat port of the economizer service valve. Superheat as measured should be 10°F (5.6°C) to 12°F (6.7°C).

**Subcooling**

Check liquid subcooling at steady full compressor load only. It is important that all fans are running for the system. Measure liquid line temperature on the copper line beside the main liquid line service valve. Measure liquid pressure at the liquid line service valve. Subcooling should be 12°F to 15°F (6.7°C to 8.3°C). No bubbles should show in the sight glass. If subcooling is out of range add or remove refrigerant as required. Do not overcharge the unit. The liquid flow to the main evaporator TXV is subcooled further by the economizer, increasing subcooling to between 22°F and 28°F (-12°C and -15°C) at ambients above 90°F.

**General Operation**

After completion of the above checks for System 1, stop the unit, switch OFF the 'SYS 1' switch on the main panel microprocessor board and repeat the process for each subsequent system. When all run correctly, stop the unit, switch all applicable switches to the 'ON' position and restart the unit.

This page intentionally left blank.

## SECTION 6 - OPERATION

### GENERAL DESCRIPTION

The units are designed to work independently, or in conjunction with other equipment via a YORK ISN building management system or other automated control system. When operating, the unit controls monitor the chilled liquid system temperature at the unit and take the appropriate action to maintain this temperature within desired limits. This action will involve running one or more compressors at a suitable load step to match the cooling effect of the refrigerating systems to the heat load on the liquid system. The heat removed from the chilled liquid is then rejected from the air cooled condenser coils.

The following sections give an overview of the operation of the unit. For detailed information, reference should be made to the Chiller Control Panel Programming and Data Access Operating Instructions for the unit (Section 8 of this manual).

### START-UP

Check the main power supplies to the unit are 'ON', all refrigerant service valves are open (counter-clockwise one turn short of fully open) and chilled liquid flow has been established (unless the unit chilled liquid pump start control is being used, in which case just ensure the pump supply is on). Ensure only the correct system switches (SYS 1-4) on the microprocessor circuit board are in the 'ON' position.

Press the 'STATUS' key on the keypad and then switch the unit ON/OFF switch below the keypad to the ON position.

The controller will perform a pre-check to ensure that the daily/holiday schedule and any remote interlocks will allow the unit to run, all safety cut-outs are satisfied and that cooling load is required (i.e. that the chilled liquid temperature is outside the set limits). Any problems found by the pre-check will be displayed if present. If no problems are present and cooling duty is required the lead compressor will start.

The display will show the anti-coincidence timer status for the lag compressor, followed by 'NO COOL LOAD' until it is called to operate by the control system.

### NORMAL RUNNING AND CYCLING

Once the unit has been started, all operations are fully automatic. After an initial period at minimum capacity on the lead compressor, the control system will adjust the unit load depending on the chilled liquid temperature and rate of temperature change. If high heat load is present, the controller will increase the capacity of the lead compressor and/or start-up the other compressor.

If very little heat load is present, the lead compressor will continue at minimum capacity or may simply stop again to avoid over cooling the liquid. If the latter is the case, one compressor will restart automatically should the liquid temperature rise again.

Once a compressor is running, discharge pressure rises as refrigerant is pumped into the air cooled condenser coils. This pressure is controlled by stages of fans to ensure maximum unit efficiency while maintaining sufficient pressure for correct operation of the condensers and expansion valves.

When a compressor is running, the controller monitors oil pressure, motor current, and various other system parameters such as discharge pressure, chilled liquid temperature, etc. Should any problems occur, the control system will immediately take appropriate action and display the nature of the fault (Section 8).

### SHUTDOWN

The unit can be stopped at any time by switching the UNIT ON/OFF switch just below the keypad to the OFF position. The compressor heaters will energize to prevent refrigerant condensing in the compressor rotors. If ambient temperatures are low, the evaporator heater mats will also energize to prevent the possibility of liquid freezing in the vessels. The mains power to the unit should not normally be switched OFF, even when the unit is not required to run.

The system switches (S2-S5) on the microboard can be used to cycle a system off. An automatic pumpdown will occur when the system is switched off.

If mains power must be switched OFF, (for extended maintenance or a shutdown period), the compressor suction, discharge and motor cooling service stop valves should be closed (clockwise) and if there is a possibility of liquid freezing due to low ambient temperatures, the evaporators should be drained. Valves should be opened and power must be switched on for at least 8 Hours (36 Hours if ambient temperature is over 86°F [30°C]) before the unit is restarted.

This page intentionally left blank.

## SECTION 7 - TECHNICAL DATA

### FLOW RATE AND PRESSURE DROP CHARTS

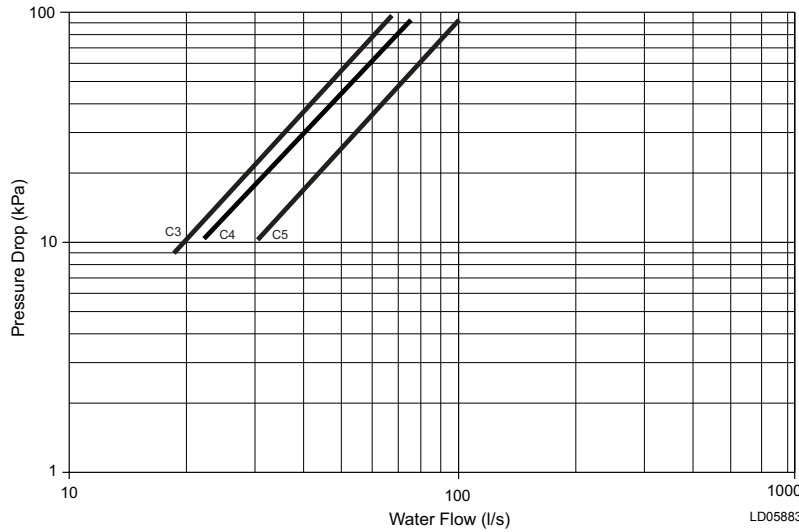

3 AND 4 CIRCUIT CHILLERS

MODEL NUMBER YCAS	EVAPORATOR
0685	C3
0775, 0835, 0905, 0965	C4
1065, 1135, 1215	C5

Pressure Conversion : Ft H2O = 2.3 x PSI

FIG. 15 – FLOW RATE AND PRESSURE DROP CHARTS

## GLYCOL CORRECTION FACTORS

The evaporator is designed in accordance with ARI-590-92 which allows for an increase in pressure drop of up to 15% above the design value given above. Debris in the water may also cause additional pressure drop.

When using glycol solutions, pressure drops are higher than with water (see correction factors to be applied when using glycol solutions).

*A = Correction Factor*

*B = Mean Temperature through Evaporator (°C)*

*C = Concentration W/W (%)*

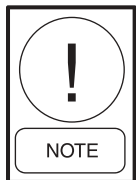

**Excessive flow, above the max GPM, will damage the evaporator.**

#### GLYCOL CORRECTION EXAMPLE: (With YCAS0140)

- RWT = 36°F LWT = 28°F
- Average Water Temperature = 32°F (= 0°C)
- For 30% Propylene Glycol: From Graph, Find Correction Factor = 1.3 @ 0°C and 30%
- Actual Measured ΔP = 12' H<sub>2</sub>O
- Corrected ΔP = 12/1.3 = 9.2' H<sub>2</sub>O
- From Flow Rate and Pressure Drop Chart, locate flow @ 9.2' ≈ 300 GPM

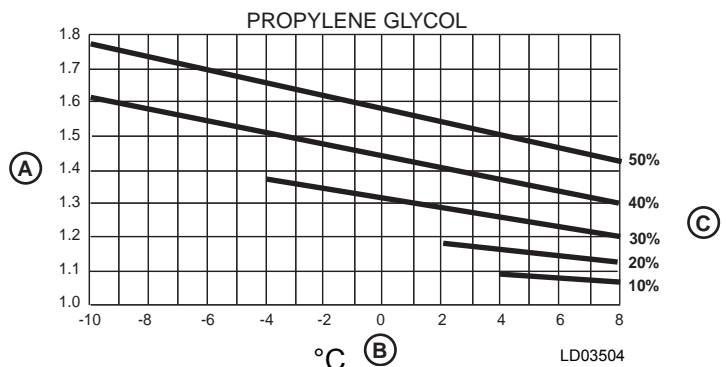
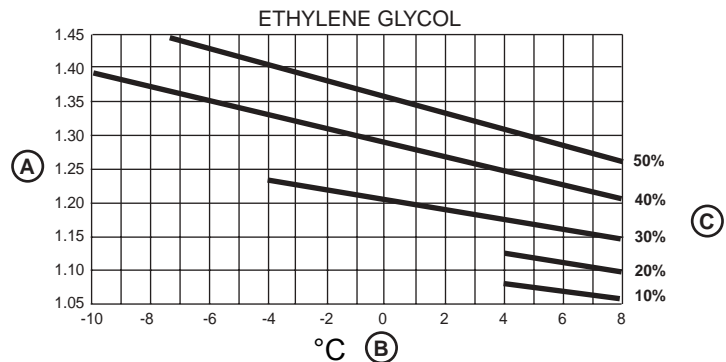

FIG. 16 – GLYCOL CORRECTION FACTORS

## TEMPERATURE AND FLOWS (SI Units)

MODEL NUMBER YCAS	LEAVING WATER TEMPERATURE (°C)		EVAPORATOR FLOW (L/S) <sup>3</sup>		AIR ON CONDENSER (°C)	
	MIN. <sup>1</sup>	MAX. <sup>2</sup>	MIN.	MAX.	MIN.	MAX
0685	5.0	13.0	18.5	67.6	-17.7	50
0775	5.0	13.0	21.0	76.0	-17.7	50
0835	5.0	13.0	21.0	76.0	-17.7	50
0905	5.0	13.0	21.0	76.0	-17.7	50
0965	5.0	13.0	21.0	76.0	-17.7	50
1065	5.0	13.0	27.2	101.0	-17.7	50
1135	5.0	13.0	27.2	101.0	-17.7	50
1215	5.0	13.0	27.2	101.0	-17.7	50

**NOTES:**

1. For leaving brine temperature below 5 °C, contact your nearest YORK office for application requirements.
2. For leaving water temperature higher than 13°C, contact the nearest YORK office for application guidelines.
3. The evaporator is protected against freeze-up to -28.8°C with an electrical heater as standard.

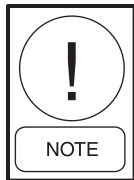

*Excessive flow, above the max GPM,  
will damage the evaporator.*

## PHYSICAL DATA - YCAS R-407C (SI UNITS)

Refrigerant R-407C Optimized	MODEL NUMBER YCAS							
	0685EB	0775EB	0835EB	0905EB	0965EB	1065EB	1135EB	1215EB
<b>General Unit Data</b>								
Unit Capacity at 7°C water & 35°C ambient, kW	692	782	829	898	923	1056	1125	1194
Number of Independent Refrigerant Circuits	3	3	3	3	3	4	4	4
Refrigerant Charge, R-407C, Ckt.-1/Ckt.-2/Ckt.-3/Ckt.-4, kg	78/78/91	88/88/88	91/88/88	91/91/91	99/99/99	88/88/88/88	91/91/88/88	91/91/91/91
Oil Charge, Ckt.-1/Ckt.-2/Ckt.-3/Ckt.-4, liters	15/15/15	15/15/15	15/15/15	15/15/15	15/15/15	15/15/15/15	15/15/15/15	15/15/15/15
<b>Shipping Weight:</b>								
Aluminum Fin Coils, kg	8,363	9,142	9,231	9,310	10,061	11,922	11,994	12,045
Copper Fin Coils, kg	9,056	9,998	10,087	10,167	11,161	13,109	13,171	13,242
<b>Operating Weight:</b>								
Aluminum Fin Coils, kg	9,081	9,817	9,906	9,986	10,737	12,877	12,950	13,000
Copper Fin Coils, kg	9,774	10,673	10,762	10,842	11,836	14,064	14,127	14,197
<b>Compressors, DXS Semihermetic Twin Screw</b>								
Quantity per Chiller	3	3	3	3	3	4	4	4
Nominal Size, Ckt.-1 / Ckt.-2/Ckt.-3/Ckt.-4	190/190/280	250/250/250	280/250/250	280/280/280	280/280/280	250/250/ 250/250	280/280/ 250/250	280/280/ 280/280
<b>Condensers, High Efficiency Fin / Tube with Integral Subcooler</b>								
Total Chiller Coil Face Area, m <sup>2</sup>	29.73	35.67	35.67	35.67	47.56	47.56	47.56	47.56
Number of Rows	3	3	3	3	3	3	3	3
Fins per meter	512	512	512	512	512	512	512	512
<b>Condenser Fans</b>								
Number, Ckt.-1/Ckt.-2/Ckt.-3/Ckt.-4	3/3/4	4/4/4	4/4/4	4/4/4	5/5/6	4/4/4/4	4/4/4/4	4/4/4/4
<b>Standard Fans</b>								
Fan Motor, HP / kW	3/2.6	3/2.6	3/2.6	3/2.6	3/2.6	3/2.6	3/2.6	3/2.6
Fan & Motor Speed, revs./sec.	15.8	15.8	15.8	15.8	15.8	15.8	15.8	15.8
Fan Diameter, mm	900	900	900	900	900	900	900	900
Fan Tip Speed, m/sec.	45	45	45	45	45	45	45	45
Total Chiller Airflow, l/sec.	72,688	87,226	87,226	87,226	116,300	116,300	116,300	116,300
<b>Low Noise Fans</b>								
Fan Motor, HP / kW	3/2.4	3/2.4	3/2.4	3/2.4	3/2.4	3/2.4	3/2.4	3/2.4
Fan & Motor Speed, revs./sec.	11.5	11.5	11.5	11.5	11.5	11.5	11.5	11.5
Fan Diameter, mm	900	900	900	900	900	900	900	900
Fan Tip Speed, m/sec.	33.75	33.75	33.75	33.75	33.75	33.75	33.75	33.75
Total Chiller Airflow, l/sec.	71,234	85,481	85,481	85,481	113,974	113,974	113,974	113,974
<b>High External Static Fans</b>								
Fan Motor, HP / kW	5 / 3.8	5 / 3.8	5 / 3.8	5 / 3.8	5 / 3.8	5 / 3.8	5 / 3.8	5 / 3.8
Fan & Motor Speed, revs./sec.	16.1	16.1	16.1	16.1	16.1	16.1	16.1	16.1
Fan Diameter, mm	900	900	900	900	900	900	900	900
Fan Tip Speed, m/sec.	45.5	45.5	45.5	45.5	45.5	45.5	45.5	45.5
Total Chiller Airflow, l/sec. (at 100 Pa external static)	72,688	87,226	87,226	87,226	116,300	116,300	116,300	116,300
<b>Evaporator, Direct Expansion</b>								
Water Volume, liters	762	914	914	914	914	1013	1013	1013
Maximum <sup>1</sup> Water Side Pressure, Bar	10	10	10	10	10	10	10	10
Maximum Refrigerant Side Pressure, Bar	24	24	24	24	24	24	24	24
Minimum Chilled Water Flow Rate, l/s	18.50	21.00	21.00	21.00	21.00	27.20	27.20	27.20
Maximum Chilled Water Flow Rate, l/s	67.64	76.03	76.03	76.03	76.03	101.00	101.00	101.00
Water Connections, inches	10	10	10	10	10	10	10	10

**NOTE:**

1. Optional 21 Bar Waterside available.

## OPERATING LIMITATIONS AND SOUND POWER DATA

### OPERATING LIMITATIONS – SI UNITS

		MIN	MAX
LEAVING CHILLED LIQUID TEMP ( °C)		4.5	15
CHILLED WATER TEMP DIFFERENCE ( °C)		3	10
WATER SIDE PRESSURE (BAR)		-	10
REFRIGERANT SIDE PRESSURE (BAR)		-	20
MODEL		COOLER FLOW LITERS/SECOND	
YCAS		MIN.	MAX.
0685EB		18.5	67.6
0775EB		21.0	76.0
0835EB		21.0	76.0
0905EB		21.0	76.0
0965EB		21.0	76.0
1065EB		27.2	101.0
1135EB		27.2	101.0
1215EB		27.2	101.0
AIR ENTERING CONDENSER (°C)	STANDARD FANS	-18	46
	HIGH PRESS. FANS	-18	46
	LOW NOISE FANS	-18	46
FAN AVAILABLE STATIC PRESSURE (Pa)	STANDARD FANS		20
	HIGH PRESS. FANS	OPTION 1	85
	HIGH PRESS. FANS	OPTION 2	150
	LOW NOISE FANS		10
ELECTRICAL THREE PHASE 50 Hz (V)			

\* Maximum Ambient w/ High Ambient Kit is 54°C.

### SOUND DATA (dBA)

MODEL	STD FAN 6-POLE MOTOR	LOW NOISE FAN 8-POLE MOTOR	LOW NOISE FAN 8-POLE MOTOR W/COMPRESSOR BLANKET	LOW NOISE FAN 8-POLE MOTOR W/ PERIMETER KIT (DISCHARGE LINE WRAPPED)	LOW NOISE FAN 8-POLE MOTOR W/COMPRESSOR BLANKET & PERIMETER KIT (DISCHARGE LINE WRAPPED)
0685EB	107	105	104	100	99
0775EB	108	106	105	101	100
0835EB	108	106	105	102	101
0905EB	108	106	105	103	102
0965EB	109	107	106	102	101
1065EB	110	108	107	102	101
1135SB	1-0	107	106	103	102
1215EB	110	108	107	103	102

## ELECTRICAL DATA

### MULTIPLE POINT POWER SUPPLY CONNECTION

Two field provided power supply circuits to the unit. Field Power Wiring connections to factory provided, Non-Fused Disconnect Switches (Opt), or Terminal Blocks (Opt) in the Option Box.

Suitable for:  
Across-The-Line-Start

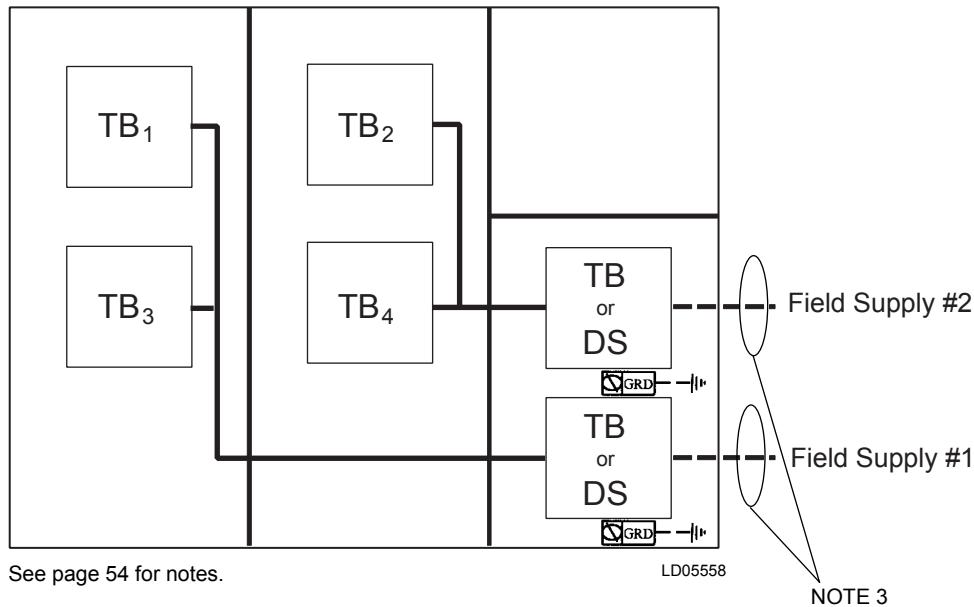

FIG. 17 – MULTIPLE POINT POWER SUPPLY CONNECTION

### MULTIPLE POINT POWER SUPPLY CONNECTION – 3 & 4 COMPRESSOR UNITS (SEE FIG. 17 OR FIG. 18)

(Two Field Provided Power Supply Circuits to the Chiller. Field Connections to Factory provided Terminal Block (Std) or Disconnects (Opt) in the Options Panel. Factory Wired Terminal Blocks or Individual System Circuit Breakers\* (opt<sup>10</sup>) in each of the two Motor Control Centers.)

Model YCAS	Volts	ELECTRICAL SYSTEM #1 FIELD SUPPLIED WIRING														
		Field Provided Power Supply				Factory Provided (Lugs) Wire Range <sup>7</sup>		Compressor #1			Compressor #3			Fan <sup>11,12</sup> Data		
		MRA <sup>1</sup> (MCA)	Min NF Disc SW <sup>2,9</sup>	Over-current Protection <sup>13</sup>		* Standard Terminal block	Optional NF Disc. Switch	RLA	Y-Δ LRA	X-LRA	RLA	Y-Δ LRA	X-LRA	Qty	FLA (ea)	LRA (ea)
				Min. <sup>3,5</sup>	Max. <sup>4,6</sup>											
0685EB	380	367	400	400	500	(2) # 2 - 4/0	(2) 3/0 - 250	99	219	692	162	267	857	7	5.7	25
0775EB	380	367	400	400	450	(2) # 2 - 4/0	(2) 3/0 - 250	128	267	857	128	267	857	8	5.7	25
0835EB	380	410	400	450	500	(2) 1/0 - 300	(2) 250 - 500	163	267	857	128	267	857	8	5.7	25
0905EB	380	452	600	500	500	(2) 1/0 - 300	(2) 250 - 500	163	267	857	163	267	857	8	5.7	25
0965EB	380	442	600	450	500	(2) 1/0 - 300	(2) 250 - 500	155	267	857	148	267	857	11	5.7	25
1065EB	380	367	400	400	450	(2) # 2 - 4/0	(2) 3/0 - 250	128	267	857	128	267	857	8	5.7	25
1135EB	380	409	400	450	500	(2) 1/0 - 300	(2) 250 - 500	162	267	857	128	267	857	8	5.7	25
1215EB	380	452	600	500	500	(2) 1/0 - 300	(2) 250 - 500	162	267	857	162	267	857	8	5.7	25

See page 54 for Electrical Data footnotes.

## ELECTRICAL DATA

### MULTIPLE POINT POWER SUPPLY CONNECTION WITH OPTIONAL INDIVIDUAL SYSTEM CIRCUIT BREAKERS

Two field provided power supply circuits to the unit with individual branch circuit protection. Field Power Wiring connections to factory provided, Non-Fused Disconnect Switches (Opt), or Terminal Blocks (Opt) in the Option Box. Factory connections to each of the Circuit Breakers in each of the two power panels.

**Suitable for:**  
**Y - Δ Start and Across the Line Start**  
**CE Mark**

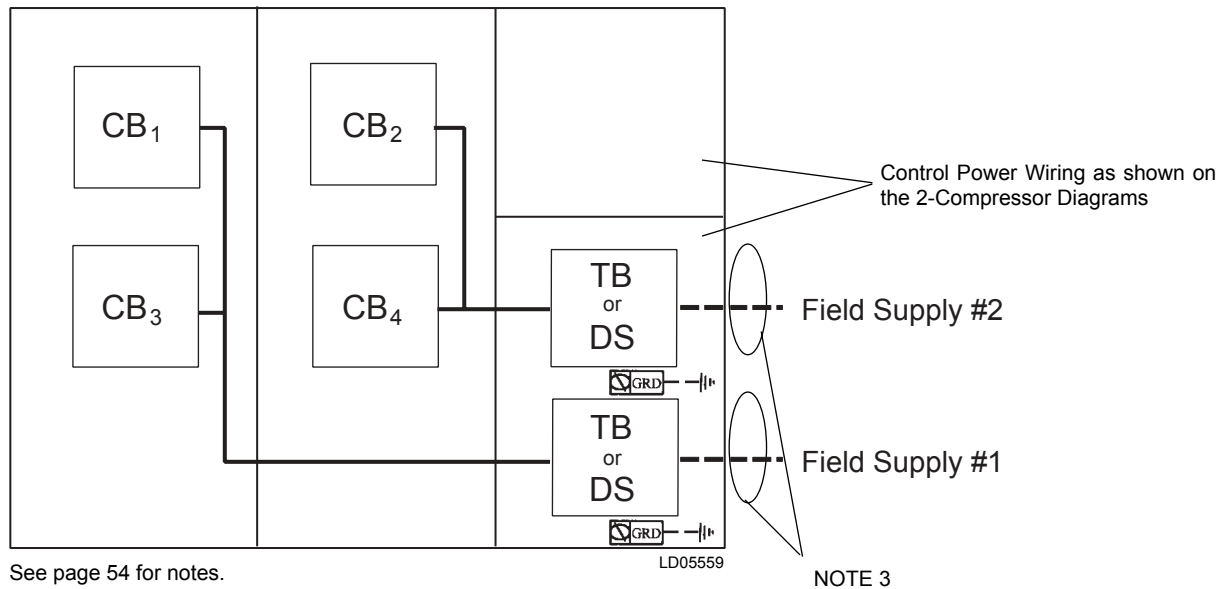

**FIG. 18 – MULTIPLE POINT POWER SUPPLY CONNECTION WITH INDIVIDUAL SYSTEM CIRCUIT BREAKERS**

Model YCAS	Volts	ELECTRICAL SYSTEM #2 FIELD SUPPLIED WIRING														
		Field Provided Power Supply				Factory Provided (Lugs) Wire Range <sup>7</sup>		Compressor #1			Compressor #3			Fan <sup>11, 12</sup> Data		
		MRA <sup>1</sup> (MCA)	Min NF Disc SW <sup>2,9</sup>	Over-current Protection <sup>13</sup>		Standard Terminal block	Optional NF Disc. Switch	RLA	Y-Δ LRA	X-LRA	RLA	Y-Δ LRA	X-LRA	Qty	FLA (ea)	LRA (ea)
				Min. <sup>3,5</sup>	Max. <sup>4,6</sup>											
0685EB	380	141	150	175	225	(1) # 2 - 4/0	(1) # 2 - 4/0	99	219	629	---	---	---	3	5.7	25
0775EB	380	184	200	225	300	(1) # 2 - 4/0	(1) #4 - 300	128	267	857	---	---	---	4	5.7	25
0835EB	380	184	200	225	300	(1) # 2 - 4/0	(1) #4 - 300	128	267	857	---	---	---	4	5.7	25
0905EB	380	226	250	300	350	(1) 1/0 - 300	(1) #4 - 300	163	267	857	---	---	---	4	5.7	25
0965EB	380	223	250	300	350	(1) 1/0 - 300	(1) #4 - 300	155	267	857	---	---	---	5	5.7	25
1065EB	380	367	400	400	450	(2) # 2 - 4/0	(2) 3/0 - 250	128	267	857	128	267	857	8	5.7	25
1135EB	380	409	400	450	500	(2) 1/0 - 300	(2) 250 - 500	162	267	857	128	267	857	8	5.7	25
1215EB	380	452	600	500	500	(2) 1/0 - 300	(2) 250 - 500	162	267	857	162	267	857	8	5.7	25

## ELECTRICAL DATA

### OPTIONAL SINGLE POINT POWER SUPPLY CONNECTION AND INDIVIDUAL SYSTEM CIRCUIT BREAKERS

**Suitable for:**  
**Y - Δ Start and**  
**Across-The-Line-Start**

One field provided power supply circuits to the unit with individual branch circuit protection. Field Power Wiring connections to factory provided, Non-Fused Disconnect Switches (Opt), or Terminal Blocks (Opt) in the Option Box.

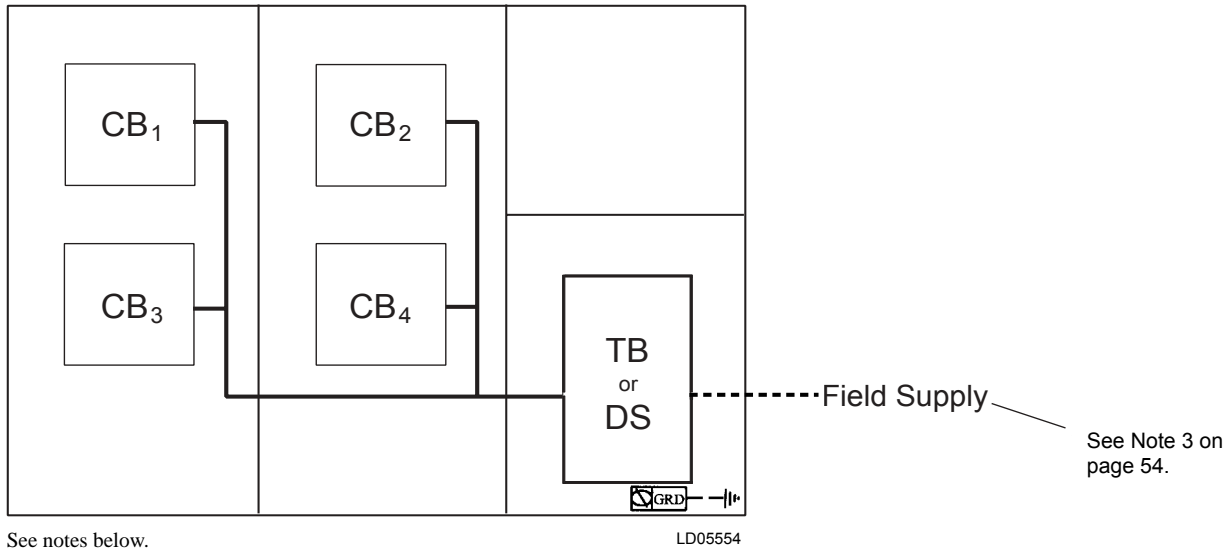

**FIG. 19 – OPTIONAL SINGLE-POINT POWER SUPPLY CONNECTION WITH INDIVIDUAL SYSTEM CIRCUIT BREAKERS**

**NOTES:**

1. ----- Dashed Line indicates Field Provided Wiring.
2. The above recommendations are based on the National Electrical Code and using copper conductors only. Field wiring must also comply with local codes.

### OPTIONAL SINGLE POINT POWER SUPPLY CONNECTION WITH INDIVIDUAL SYSTEM CIRCUIT BREAKERS – 3 AND 4 COMPRESSOR UNITS (SEE FIG. 19)

One Field Provided Power Supply Circuit to the chiller. Field connections to Factory Provided Terminal Block (standard) or Non-Fused Disconnect (option) in the Options Panel. Individual System Circuit Breakers in each Motor Control Center.

CHILLER MODEL YCAS	FIELD-SUPPLIED WIRING					
	FIELD PROVIDED POWER SUPPLY				FACTORY PROVIDED (LUGS) WIRE RANGE <sup>7</sup>	
	MRA <sup>1</sup>	MIN NF DISC SW <sup>2,9</sup>	OVER-CURRENT PROTECTION		STANDARD TERMINAL BLOCK	OPTIONAL NF DISC. SWITCH
			MIN. <sup>3,5</sup>	MAX. <sup>4,6</sup>		
<b>0685EB</b>	482	600	600	600	(2) 2/0 - 500	(2) 250 - 500
<b>0775EB</b>	517	600	600	600	(2) 2/0 - 500	(2) 250 - 500
<b>0835EB</b>	560	600	700	700	(2) 2/0 - 500	(2) 250 - 500
<b>0905EB</b>	637	800	700	700	(3) 1/0 - 300	(3) 2/0 - 400
<b>0965EB</b>	625	800	800	800	(3) 1/0 - 300	(3) 2/0 - 400
<b>1065EB</b>	669	800	700	700	(3) 2/0 - 500	(3) 2/0 - 400
<b>1135EB</b>	745	800	800	800	(3) 2/0 - 500	(4) 4/0 - 500
<b>1215EB</b>	822	1000	1000	1000	(3) 2/0 - 500	(4) 4/0 - 500

See page 54 for Electrical Data footnotes.

# ELECTRICAL DATA

ELECTRICAL SYSTEM #1									ELECTRICAL SYSTEM #2								
Compressor #1 Data			Compressor #3 Data			Fan Data <sup>11, 12</sup>			Compressor #2 Data			Compressor #4 Data			Fan Data <sup>11, 12</sup>		
RLA	Y-Δ LRA	X-LRA	RLA	Y-Δ LRA	X-LRA	Qty	FLA (ea)	LRA (ea)	RLA	Y-Δ LRA	X-LRA	RLA	Y-Δ LRA	X-LRA	Qty	FLA (ea)	LRA
99	219	692	162	267	857	7	5.7	25	(ea)								
128	267	857	128	267	857	8	5.7	25	99	219	629	—	—	—	3	5.7	25
163	267	857	128	267	857	8	5.7	25	128	267	857	—	—	—	4	5.7	25
163	267	857	163	267	857	8	5.7	25	128	267	857	—	—	—	4	5.7	25
155	267	857	148	267	857	11	5.7	25	163	267	857	—	—	—	4	5.7	25
128	267	857	128	267	857	8	5.7	25	155	267	857	—	—	—	5	5.7	25
162	267	857	128	267	857	8	5.7	25	128	267	857	128	267	857	8	5.7	25
162	267	857	162	267	857	8	5.7	25	162	267	857	128	267	857	8	5.7	25

## ELECTRICAL NOTES

### NOTES

1. MRA is Maximum Running Amps, the maximum continuous current at any operating point in the rating range. Also referred to as MCA, or Minimum Circuit Ampacity to be provided by the installer. If a Factory Mounted Control Transformer is provided, add 3 amps to the system #1 MCA values in the YCAS Tables.
2. The recommended disconnect switch is based on a minimum of 115% of the summation rated load amps of all the loads included in the circuit, per N.E.C. 440 - 12A1.
3. Minimum recommended fuse size is based on 150% of the largest motor RLA plus 100% of the remaining RLAs. Minimum fuse rating = (1.5 x largest compressor RLA) + other compressor RLAs + (# fans x each fan motor FLA).
4. Maximum dual element fuse size is based on 225% maximum plus 100% of the rated load amps for all other loads included in the circuit, per N.E.C. 440-22. Maximum fuse rating = (2.25 x largest compressor RLA) + other compressor RLAs + (# fans x each fan motor FLA).
5. Minimum recommended circuit breaker is 150% maximum plus 100% of rated load amps included in the circuit. Minimum circuit breaker rating = (1.5 x largest compressor RLA) + other compressor RLAs + (# fans x each fan motor FLA).
6. Maximum circuit breaker is based on 225% maximum plus 100% of the rated load amps for all loads included in the circuit, per circuit, per U.L. **1995** Fig. 36.2. Maximum circuit breaker rating = (2.25 x largest compressor RLA) + other compressor RLAs + (# fans x each fan motor FLA).
7. The Incoming Wire Range is the minimum and maximum wire size that can be accommodated by unit wiring lugs. The (1), (2), or (3) indicate the number of termination points or lugs which are available per phase. Actual wire size and number of wires per phase must be determined based on ampacity and job requirements using N.E.C. wire sizing information. The above recommendations are based on the National Electrical Code and using **copper connectors** only. Field wiring must also comply with local codes.
8. A ground lug is provided for each compressor system to accommodate field grounding conductor per N.E.C. Article 250-54. A control circuit grounding lug is also supplied.
9. The field supplied disconnect is a "Disconnecting Means" as defined in N.E.C. 100.B, and is intended for isolating the unit from the available power supply to perform maintenance and troubleshooting. This disconnect is not intended to be a Load Break Device.
10. Two-compressor machines with single-point power connection, and equipped with Star-Delta compressor motor start must also include Factory provided circuit breakers in each motor control center.
11. Consult factory for Electrical Data on units equipped with "High Static Fan" option. 50Hz High Static Fans are 3.5kW each.
12. FLA for each "Low Noise Fan" motor:  $380v/50Hz = 4.1A$ .

### LEGEND

ACR-LINE	ACROSS THE LINE START
CB	CIRCUIT BREAKER
DE FU	DUAL ELEMENT FUSE
DISC SW	DISCONNECT SWITCH
FACT MOUNT CB	FACTORY-MOUNTED CIRCUIT BREAKER
FACT MOUNT FUSE	FACTORY-MOUNTED FUSES
FLA	FULL LOAD AMPS
HZ	HERTZ
MAX	MAXIMUM
MCA	MINIMUM CIRCUIT AMPACITY
MIN	MINIMUM
MIN NF	MINIMUM NON-FUSED
RLA	RUNNING LOAD AMPS
S.P. WIRE	SINGLE-POINT WIRING
UNIT MTD SERV SW	UNIT-MOUNTED SERVICE (NON-FUSED DISCONNECT SWITCH)
WYE-DELTA	WYE-DELTA START
XLRA	ACROSS-THE-LINE INRUSH LOCKED ROTOR AMPS
YLRA	WYE-DELTA INRUSH LOCKED ROTOR AMPS

## ELECTRICAL DATA

### CONTROL POWER SUPPLY (UNITS WITHOUT STANDARD CONTROL CIRCUIT TRANSFORMER)

NO. OF COMPRESSORS	CONTROL POWER SUPPLY	MCA (MAX LOAD CURRENT)	MAX DUAL ELEMENT FUSE SIZE	NON-FUSED DISCONNECT SWITCH SIZE
3 or 4 (Non-CE 50/60Hz)	115V-1Ø	30A	30A	30A

### CONTROL POWER SUPPLY (UNITS WITH STANDARD CONTROL CIRCUIT TRANSFORMER)

NO. OF COMPRESSORS	CONTROL POWER SUPPLY	MCA (MAX LOAD CURRENT)	RECOMMENDED DUAL ELEMENT FUSE SIZE	NON-FUSED DISCONNECT SWITCH SIZE
3 or 4	400V - 50 HZ	9.4A	15A	— — —

**TABLE 2 – COMPRESSOR DATA**

MAXIMUM kW AND AMPERAGE VALUES FOR DXST COMPRESSORS																	
	COMPRESSOR MODEL AND VOLTAGE CODE																
	DXS45LA – MOTOR CODE A (B5N, B5E, B6N, B6E)					DXS36LA – MOTOR CODE A (A5N, A5E, A6N, A6E)					DXS24LA – MOTOR CODE (TBD) (C5N, C5E, C6N, C6E)						
	VOLTAGE CODE-																
MAX KW																	
MAX AMPS																	

## ELEMENTARY WIRING DIAGRAM YCAS0685 - YCAS0965 (3 COMPRESSOR)

035-15937-103  
Rev - A

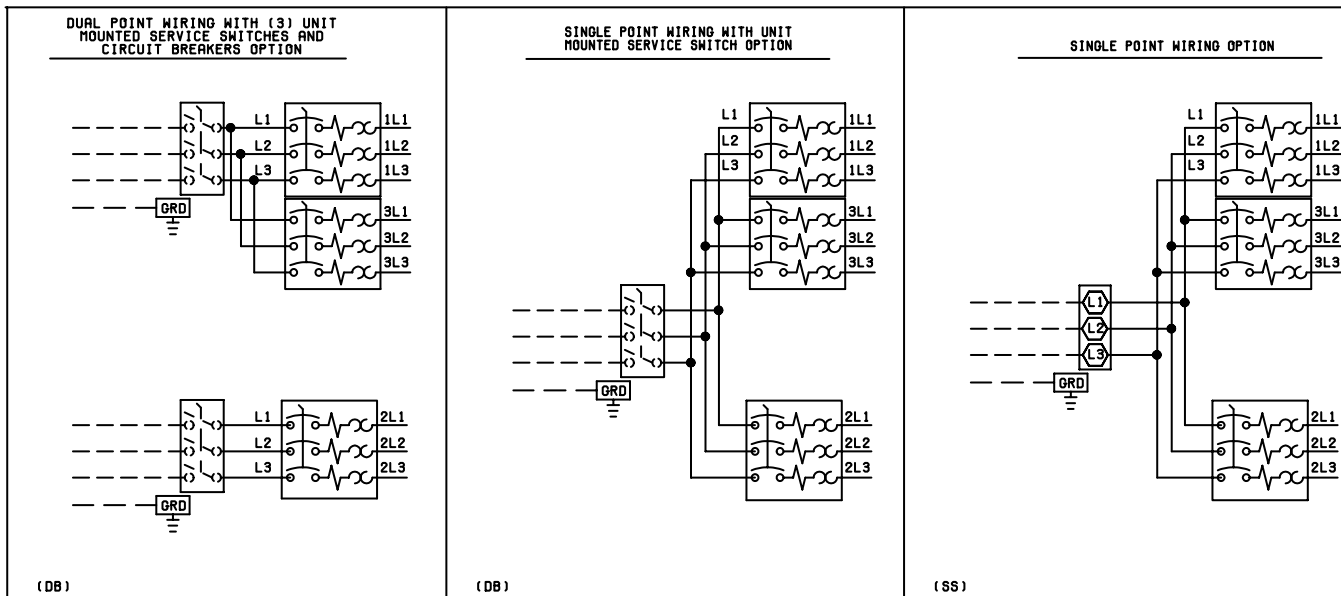
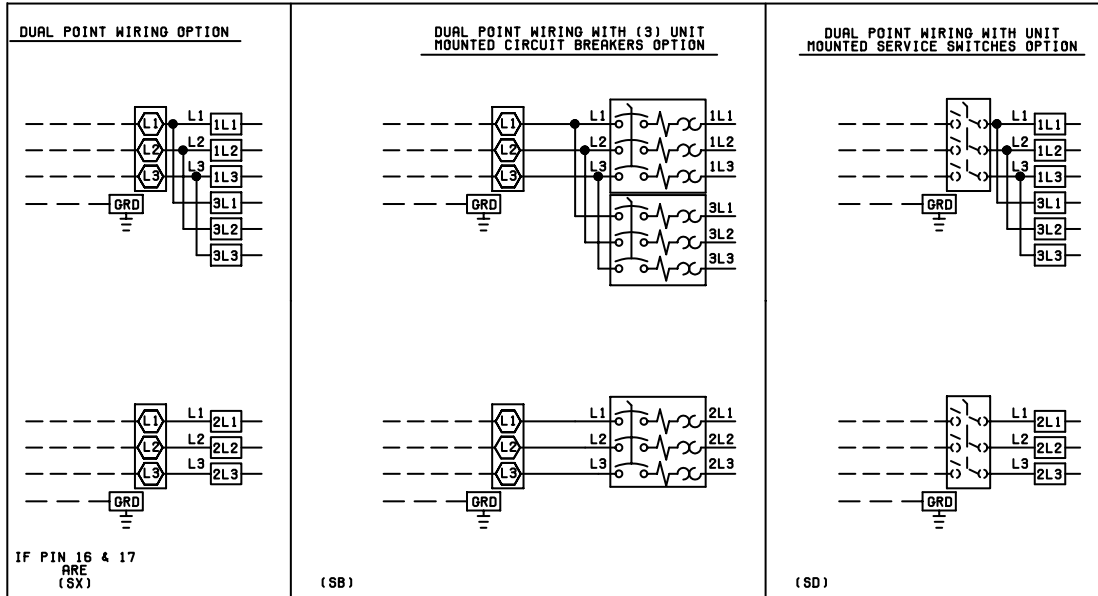

LD09350

**FIG. 20 – ELEMENTARY WIRING DIAGRAM – DXST DIRECT DRIVE 3 COMPRESSOR**

# ELEMENTARY WIRING DIAGRAM YCAS0685 - YCAS0965 (3 COMPRESSOR) ACROSS-THE-LINE START

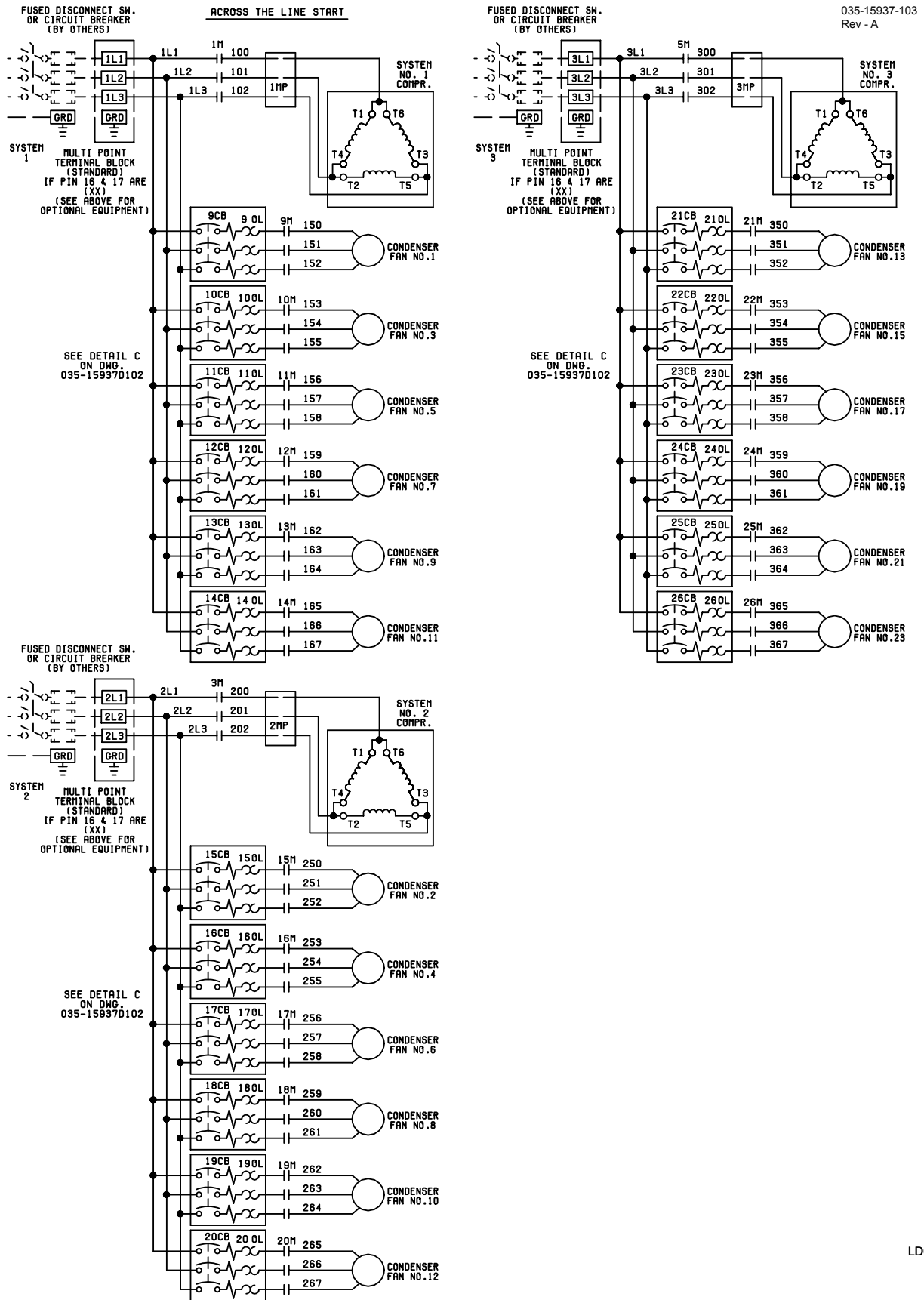

7

**FIG. 21 – ELEMENTARY WIRING DIAGRAM – ACROSS-THE-LINE START 3 COMPRESSOR**  
YORK INTERNATIONAL

# ELEMENTARY WIRING DIAGRAM YCAS0685 - YCAS0965 (3 COMPRESSOR) WYE DELTA START

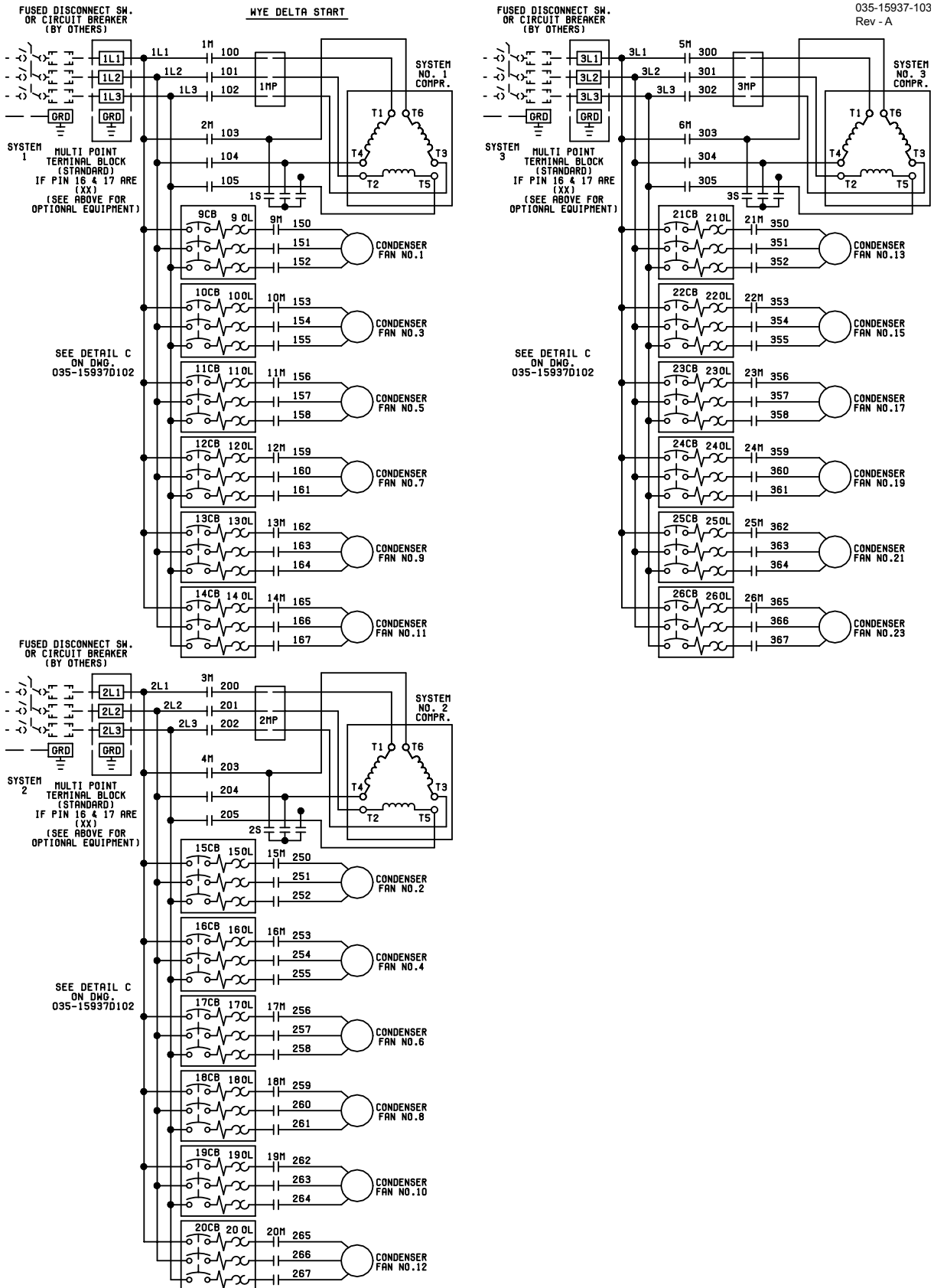

FIG. 22 – ELEMENTARY WIRING DIAGRAM – WYE DELTA START 3 COMPRESSOR

# ELEMENTARY WIRING DIAGRAM (YCAS0685 - YCAS0965) ACROSS-THE-LINE START AND WYE-DELTA START

035-15937-102  
REV D

**NOTES:**

1. Field wiring to be in accordance with the current edition of the National Electrical Code as well as all other applicable codes and specifications.
2. Contacts must be suitable for switching 24VDC, (Gold contacts recommend). Wiring shall not be run in the same conduit with any line voltage wiring.
3. To cycle the unit on and off automatically with contact shown, install a cycling device in series with the flow switch (FLSW). See note 2 for contact rating and wiring specifications.
4. To stop unit (Emergency Stop) with contacts other than those shown, install the stop contact between terminals 5 and 1. If a stop device is not installed, a jumper must be connected between terminals 5 and 1. Device must have a minimum contact rating of 100A at 115 volts A.C.
5. Alarm contacts are for annunciating alarm/unit malfunction. Contacts are rated at 115V, 100VA, load only, and must be suppressed at load by user.
6. See Installation, Operation and Maintenance Manual when optional equipment is used.
7. Jumper must be installed for three compressor operation.

**LEGEND**

<p>T S</p> <p>⬡</p> <p>△</p> <p>□</p> <p>—————</p> <p>-----</p> <p>- - - - -</p>	<p>Transient Voltage Suppression</p> <p>Terminal Block for Customer Connections</p> <p>Terminal Block for Customer Low Voltage (Class 2) Connections. See Note 2</p> <p>Terminal Block for YORK Connections Only</p> <p>Wiring and Components by YORK</p> <p>Optional Equipment</p> <p>Wiring and/or Components by Others</p>
--	---

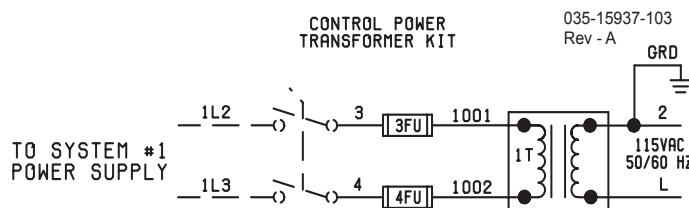

LD09351

**FIG. 23 – CONTROL POWER TRANSFORMER KIT**

# ELEMENTARY WIRING DIAGRAM YCAS0685 - YCAS0965 (3 COMPRESSOR)

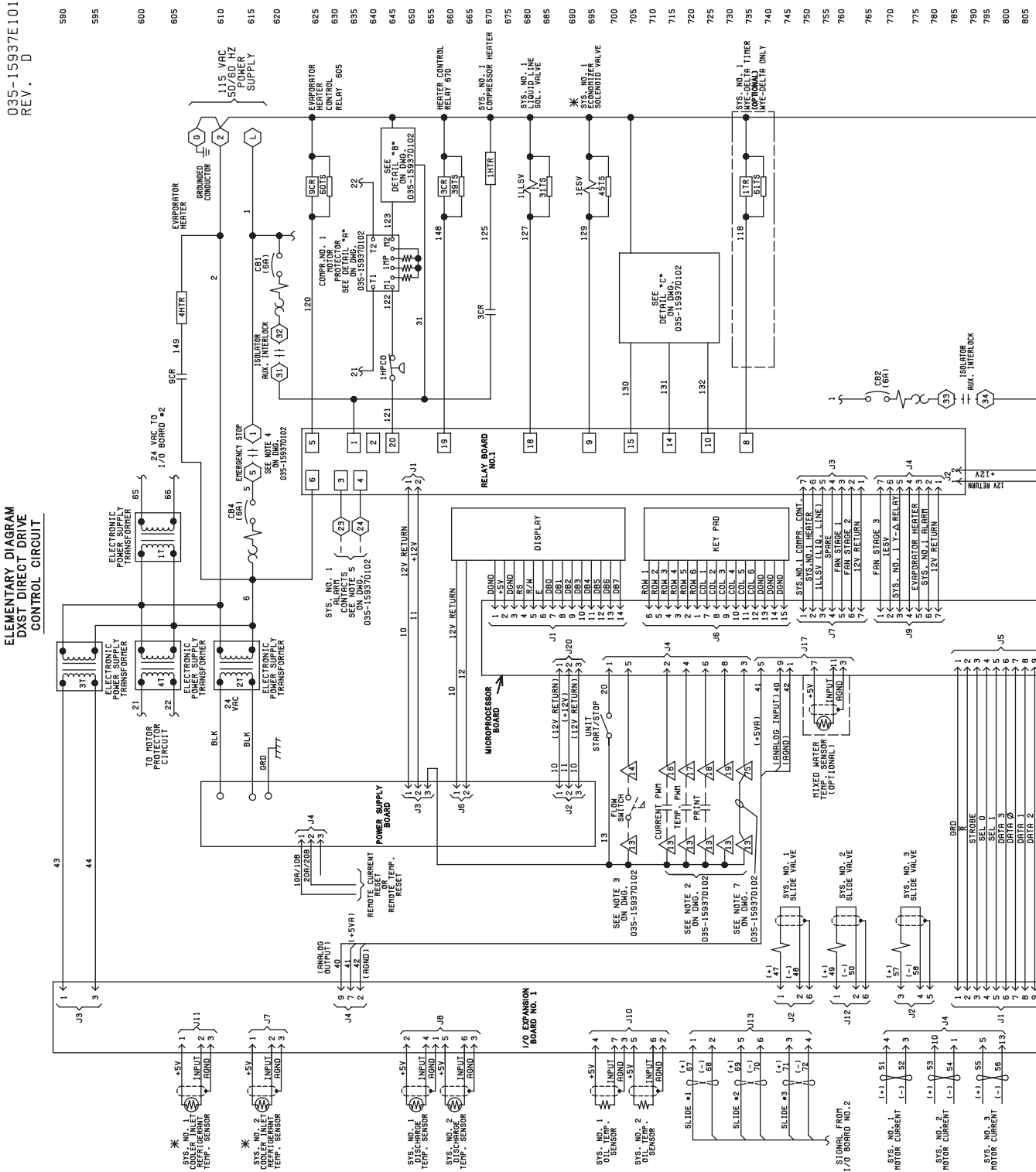

FIG. 24 – ELEMENTARY WIRING DIAGRAM DXST DIRECT DRIVE CONTROL CIRCUIT

LD010031

**CAUTION:**

No Controls (relays, etc.) should be mounted in the Smart Panel enclosure or connected to power supplies in the control panel. Additionally, control wiring not connected to the Smart Panel should not be run through the cabinet. This could result in nuisance faults.

**CAUTION:**

Any inductive devices (relays) wired in series with the flow switch for start/stop, into the Alarm circuitry, or pilot relays for pump starters wired through motor contactor auxiliary contacts must be suppressed with YORK P/N 031-00808-000 suppressor across the relay/contactor coil.

Any contacts connected to flow switch inputs or BAS inputs on terminals 13 - 19 or TB3, or any other terminals, must be suppressed with a YORK P/N 031-00808-000 suppressor across the relay/contactor coil.

**CAUTION:**

Control wiring connected to the control panel should never be run in the same conduit with power wiring.

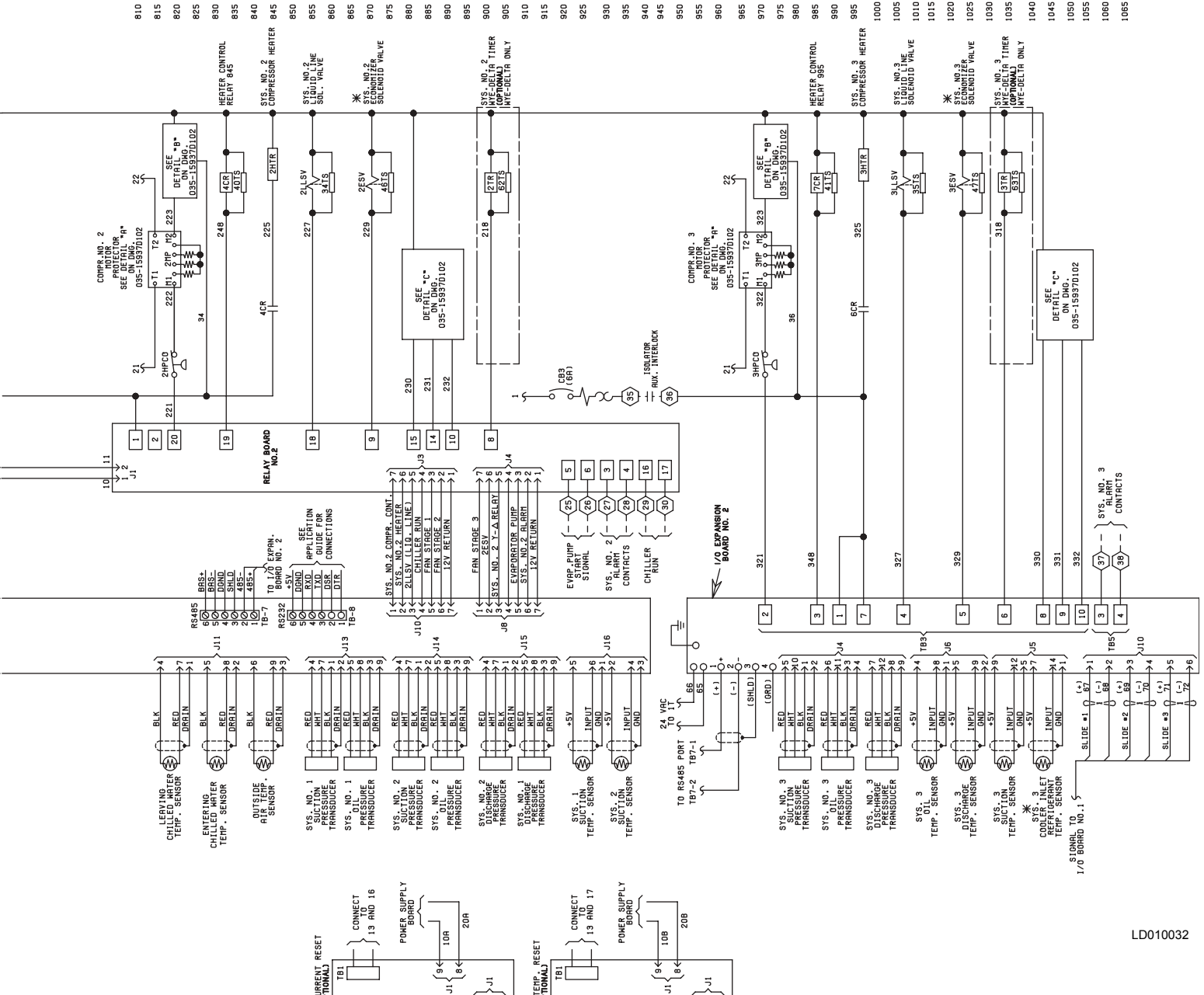

LD010032

**CONTROL POWER SUPPLY**

UNIT VOLTAGE	CONTROL POWER SUPPLY	MIN CIRCUIT AMP.	MAX DUAL ELEMENT FUSE SIZE	NON-FUSED DISC. SWITCH SIZE
ALL MODELS W/O TRANS.	115-150/60	20A	20A 250V	30A 240V
MODELS WITH TRANS.	-17 -28 -46 -58	200-1-60 230-1-60 400-1-60 575-1-60	15A 15A 250V 8A 8A 600V	30A 240V 30A 240V 30A 480V 30A 600V

\* All primary and secondary wiring between transformer and control panel included.

## CONNECTION DIAGRAM ELEC. BOX (YCAS0685 - YCAS0965)

035-15937E104  
REV. E

### STANDARD AND REMOTE EVAP. UNITS

J1, J2, J3, J3A, J4, J4A, — POWER PANEL  
J5, J6, J7, J8, P7 & P8

P1, P2, P3, P3A, — ELECTRONIC (MICRO) PANEL  
P4, P4A, P5, & P6

NOTE: I. WIRE NUMBERS IDENTIFIED IN  
(PARENTHESIS) INDICATE THE  
ACTUAL HARNESS CODE STAMPED  
ON THE WIRE.

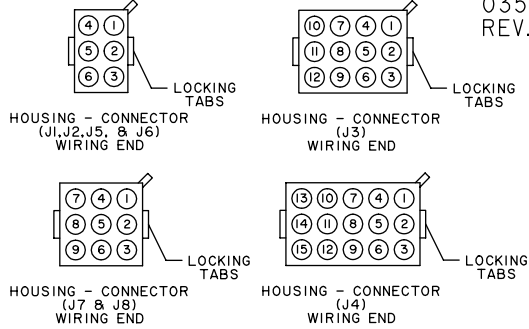

- 1CR THRU 4CR, 9CR/ -CONTROL RELAYS
- K1 THRU -K4, -K9
- CB1, CB2, CB3/ -CIRCUIT BREAKERS
- QCB1, -QCB2, -QCB3
- 9CB THRU 13CB -OVERLOAD CIRCUIT BREAKERS (SYS. #1)
- 15CB THRU 19CB -OVERLOAD CIRCUIT BREAKERS (SYS. #2)
- 9 OL THRU 13 OL -MOTOR OVERLOADS (SYS. #1)
- 15 OL THRU 19 OL -MOTOR OVERLOADS (SYS. #2)
- QFCB9 THRU -QFCB13 -MOTOR OVERLOADS W/OVERLOAD CIRCUIT BREAKERS (SYS. #1)
- QFCB15 THRU -QFCB19 -MOTOR OVERLOADS W/OVERLOAD CIRCUIT BREAKERS (SYS. #2)

#### LEGEND

- 1M, 3M/ -COMPRESSOR CONTACTORS
- 1-KLC OR 1-KALC, 2-KLC OR 2-KALC
- 2M, 4M/ -COMPRESSOR CONTACTORS
- 1-KDC, 2-KDC
- 1S, 2S/ -COMPRESSOR CONTACTORS
- 1-KSC, 2-KSC
- 9M THRU 13M/ -CONDENSER FAN CONTACTORS (SYS. #1)
- KF9 THRU -KF13
- 15M THRU 19M/ -CONDENSER FAN CONTACTORS (SYS. #2)
- KF15 THRU -KF19
- 1MP/1-FMP -MOTOR PROTECTOR (SYS. #1)
- 2MP/2-FMP -MOTOR PROTECTOR (SYS. #2)

- 2T, 3T, 4T/ -MICRO PANEL TRANSFORMERS
- T2, -T3, -T4
- 1TR, 2TR/ -TIMER RELAYS
- K10, -K11
- TS/-ES -TRANSIENT SUPPRESSORS
- PTB1, PTB2/ -POWER TERMINAL BLOCK
- 1-XTB, 2-XTB
- MCB1, MCB2/ -MOTOR CIRCUIT BREAKER
- 1-QCB, 2-QCB
- DSW1, DSW2/ -DISCONNECT SERVICE SWITCH
- 1-QSD, 2-QSD
- -WIRING BY YORK
- -WIRING BY OTHERS
- ===== -OPTIONAL WIRING AND/OR COMPONENTS

PLUG NO.	WIRE NO.	PLUG PIN NO.	PLUG NO.	WIRE NO.	PLUG PIN NO.	PLUG NO.	WIRE NO.	PLUG PIN NO.	PLUG NO.	WIRE NO.	PLUG PIN NO.																																																																																																								
P1	21	I	P2	21	I	P3	2	I	P4	2	I																																																																																																								
	22	2		22	3		22	4		22	5	31	4	32	5	33	4	34	5	GRD	2	I25	4	I29	5	I27	6	I21	II	I22	I2	2	I	2	2	22	3	3Y	4	3X	5	2	I	2	2	22	3	3Y	4	3X	5	2	I	GRD	2	I25A	4	I29A	5	I27A	6	I21A	II	I22	I2	2	I	GRD	2	225A	3	227A	4	229A	5	221A	II	222	I2	225	I	2	2	223	3	240	4	241	5	242	6	34	7	TRX	8	44	9	225	1	2	2	23	3	40	4	41	5	42	6	3X	7	TRX	8	44	9
	22	3		22	4		22	5		31	4	32	5	33	4	34	5	GRD	2	I25	4	I29	5	I27	6	I21	II	I22	I2	2	I	2	2	22	3	3Y	4	3X	5	2	I	2	2	22	3	3Y	4	3X	5	2	I	GRD	2	I25A	4	I29A	5	I27A	6	I21A	II	I22	I2	2	I	GRD	2	225A	3	227A	4	229A	5	221A	II	222	I2	225	I	2	2	223	3	240	4	241	5	242	6	34	7	TRX	8	44	9	225	1	2	2	23	3	40	4	41	5	42	6	3X	7	TRX	8	44	9		
	22	4		22	5		31	4		32	5	33	4	34	5	GRD	2	I25	4	I29	5	I27	6	I21	II	I22	I2	2	I	2	2	22	3	3Y	4	3X	5	2	I	2	2	22	3	3Y	4	3X	5	2	I	GRD	2	I25A	4	I29A	5	I27A	6	I21A	II	I22	I2	2	I	GRD	2	225A	3	227A	4	229A	5	221A	II	222	I2	225	I	2	2	223	3	240	4	241	5	242	6	34	7	TRX	8	44	9	225	1	2	2	23	3	40	4	41	5	42	6	3X	7	TRX	8	44	9				
	22	5		31	4		32	5		33	4	34	5	GRD	2	I25	4	I29	5	I27	6	I21	II	I22	I2	2	I	2	2	22	3	3Y	4	3X	5	2	I	2	2	22	3	3Y	4	3X	5	2	I	GRD	2	I25A	4	I29A	5	I27A	6	I21A	II	I22	I2	2	I	GRD	2	225A	3	227A	4	229A	5	221A	II	222	I2	225	I	2	2	223	3	240	4	241	5	242	6	34	7	TRX	8	44	9	225	1	2	2	23	3	40	4	41	5	42	6	3X	7	TRX	8	44	9						
31	4	32	5	33	4		34	5		GRD	2	I25	4	I29	5	I27	6	I21	II	I22	I2	2	I	2	2	22	3	3Y	4	3X	5	2	I	2	2	22	3	3Y	4	3X	5	2	I	GRD	2	I25A	4	I29A	5	I27A	6	I21A	II	I22	I2	2	I	GRD	2	225A	3	227A	4	229A	5	221A	II	222	I2	225	I	2	2	223	3	240	4	241	5	242	6	34	7	TRX	8	44	9	225	1	2	2	23	3	40	4	41	5	42	6	3X	7	TRX	8	44	9										
32	5	33	4	34	5	GRD	2	I25		4	I29	5	I27	6	I21	II	I22	I2	2	I	2	2	22	3	3Y	4	3X	5	2	I	2	2	22	3	3Y	4	3X	5	2	I	GRD	2	I25A	4	I29A	5	I27A	6	I21A	II	I22	I2	2	I	GRD	2	225A	3	227A	4	229A	5	221A	II	222	I2	225	I	2	2	223	3	240	4	241	5	242	6	34	7	TRX	8	44	9	225	1	2	2	23	3	40	4	41	5	42	6	3X	7	TRX	8	44	9													
33	4	34	5	GRD	2	I25	4	I29	5	I27	6	I21	II	I22	I2	2	I	2	2	22	3	3Y	4	3X	5	2	I	2	2	22	3	3Y	4	3X	5	2	I	GRD	2	I25A	4	I29A	5	I27A	6	I21A	II	I22	I2	2	I	GRD	2	225A	3	227A	4	229A	5	221A	II	222	I2	225	I	2	2	223	3	240	4	241	5	242	6	34	7	TRX	8	44	9	225	1	2	2	23	3	40	4	41	5	42	6	3X	7	TRX	8	44	9																
34	5	GRD	2	I25	4	I29	5	I27	6	I21	II	I22	I2	2	I	2	2	22	3	3Y	4	3X	5	2	I	2	2	22	3	3Y	4	3X	5	2	I	GRD	2	I25A	4	I29A	5	I27A	6	I21A	II	I22	I2	2	I	GRD	2	225A	3	227A	4	229A	5	221A	II	222	I2	225	I	2	2	223	3	240	4	241	5	242	6	34	7	TRX	8	44	9	225	1	2	2	23	3	40	4	41	5	42	6	3X	7	TRX	8	44	9																		
GRD	2	I25	4	I29	5	I27	6	I21	II	I22	I2	2	I	2	2	22	3	3Y	4	3X	5	2	I	2	2	22	3	3Y	4	3X	5	2	I	GRD	2	I25A	4	I29A	5	I27A	6	I21A	II	I22	I2	2	I	GRD	2	225A	3	227A	4	229A	5	221A	II	222	I2	225	I	2	2	223	3	240	4	241	5	242	6	34	7	TRX	8	44	9	225	1	2	2	23	3	40	4	41	5	42	6	3X	7	TRX	8	44	9																				
I25	4	I29	5	I27	6	I21	II	I22	I2	2	I	2	2	22	3	3Y	4	3X	5	2	I	2	2	22	3	3Y	4	3X	5	2	I	GRD	2	I25A	4	I29A	5	I27A	6	I21A	II	I22	I2	2	I	GRD	2	225A	3	227A	4	229A	5	221A	II	222	I2	225	I	2	2	223	3	240	4	241	5	242	6	34	7	TRX	8	44	9	225	1	2	2	23	3	40	4	41	5	42	6	3X	7	TRX	8	44	9																						
I29	5	I27	6	I21	II	I22	I2	2	I	2	2	22	3	3Y	4	3X	5	2	I	2	2	22	3	3Y	4	3X	5	2	I	GRD	2	I25A	4	I29A	5	I27A	6	I21A	II	I22	I2	2	I	GRD	2	225A	3	227A	4	229A	5	221A	II	222	I2	225	I	2	2	223	3	240	4	241	5	242	6	34	7	TRX	8	44	9	225	1	2	2	23	3	40	4	41	5	42	6	3X	7	TRX	8	44	9																								
I27	6	I21	II	I22	I2	2	I	2	2	22	3	3Y	4	3X	5	2	I	2	2	22	3	3Y	4	3X	5	2	I	GRD	2	I25A	4	I29A	5	I27A	6	I21A	II	I22	I2	2	I	GRD	2	225A	3	227A	4	229A	5	221A	II	222	I2	225	I	2	2	223	3	240	4	241	5	242	6	34	7	TRX	8	44	9	225	1	2	2	23	3	40	4	41	5	42	6	3X	7	TRX	8	44	9																										
I21	II	I22	I2	2	I	2	2	22	3	3Y	4	3X	5	2	I	2	2	22	3	3Y	4	3X	5	2	I	GRD	2	I25A	4	I29A	5	I27A	6	I21A	II	I22	I2	2	I	GRD	2	225A	3	227A	4	229A	5	221A	II	222	I2	225	I	2	2	223	3	240	4	241	5	242	6	34	7	TRX	8	44	9	225	1	2	2	23	3	40	4	41	5	42	6	3X	7	TRX	8	44	9																												
I22	I2	2	I	2	2	22	3	3Y	4	3X	5	2	I	2	2	22	3	3Y	4	3X	5	2	I	GRD	2	I25A	4	I29A	5	I27A	6	I21A	II	I22	I2	2	I	GRD	2	225A	3	227A	4	229A	5	221A	II	222	I2	225	I	2	2	223	3	240	4	241	5	242	6	34	7	TRX	8	44	9	225	1	2	2	23	3	40	4	41	5	42	6	3X	7	TRX	8	44	9																														
2	I	2	2	22	3	3Y	4	3X	5	2	I	2	2	22	3	3Y	4	3X	5	2	I	GRD	2	I25A	4	I29A	5	I27A	6	I21A	II	I22	I2	2	I	GRD	2	225A	3	227A	4	229A	5	221A	II	222	I2	225	I	2	2	223	3	240	4	241	5	242	6	34	7	TRX	8	44	9	225	1	2	2	23	3	40	4	41	5	42	6	3X	7	TRX	8	44	9																																
2	2	22	3	3Y	4	3X	5	2	I	2	2	22	3	3Y	4	3X	5	2	I	GRD	2	I25A	4	I29A	5	I27A	6	I21A	II	I22	I2	2	I	GRD	2	225A	3	227A	4	229A	5	221A	II	222	I2	225	I	2	2	223	3	240	4	241	5	242	6	34	7	TRX	8	44	9	225	1	2	2	23	3	40	4	41	5	42	6	3X	7	TRX	8	44	9																																		
22	3	3Y	4	3X	5	2	I	2	2	22	3	3Y	4	3X	5	2	I	GRD	2	I25A	4	I29A	5	I27A	6	I21A	II	I22	I2	2	I	GRD	2	225A	3	227A	4	229A	5	221A	II	222	I2	225	I	2	2	223	3	240	4	241	5	242	6	34	7	TRX	8	44	9	225	1	2	2	23	3	40	4	41	5	42	6	3X	7	TRX	8	44	9																																				
3Y	4	3X	5	2	I	2	2	22	3	3Y	4	3X	5	2	I	GRD	2	I25A	4	I29A	5	I27A	6	I21A	II	I22	I2	2	I	GRD	2	225A	3	227A	4	229A	5	221A	II	222	I2	225	I	2	2	223	3	240	4	241	5	242	6	34	7	TRX	8	44	9	225	1	2	2	23	3	40	4	41	5	42	6	3X	7	TRX	8	44	9																																						
3X	5	2	I	2	2	22	3	3Y	4	3X	5	2	I	GRD	2	I25A	4	I29A	5	I27A	6	I21A	II	I22	I2	2	I	GRD	2	225A	3	227A	4	229A	5	221A	II	222	I2	225	I	2	2	223	3	240	4	241	5	242	6	34	7	TRX	8	44	9	225	1	2	2	23	3	40	4	41	5	42	6	3X	7	TRX	8	44	9																																								
2	I	2	2	22	3	3Y	4	3X	5	2	I	GRD	2	I25A	4	I29A	5	I27A	6	I21A	II	I22	I2	2	I	GRD	2	225A	3	227A	4	229A	5	221A	II	222	I2	225	I	2	2	223	3	240	4	241	5	242	6	34	7	TRX	8	44	9	225	1	2	2	23	3	40	4	41	5	42	6	3X	7	TRX	8	44	9																																										
2	2	22	3	3Y	4	3X	5	2	I	GRD	2	I25A	4	I29A	5	I27A	6	I21A	II	I22	I2	2	I	GRD	2	225A	3	227A	4	229A	5	221A	II	222	I2	225	I	2	2	223	3	240	4	241	5	242	6	34	7	TRX	8	44	9	225	1	2	2	23	3	40	4	41	5	42	6	3X	7	TRX	8	44	9																																												
22	3	3Y	4	3X	5	2	I	GRD	2	I25A	4	I29A	5	I27A	6	I21A	II	I22	I2	2	I	GRD	2	225A	3	227A	4	229A	5	221A	II	222	I2	225	I	2	2	223	3	240	4	241	5	242	6	34	7	TRX	8	44	9	225	1	2	2	23	3	40	4	41	5	42	6	3X	7	TRX	8	44	9																																														
3Y	4	3X	5	2	I	GRD	2	I25A	4	I29A	5	I27A	6	I21A	II	I22	I2	2	I	GRD	2	225A	3	227A	4	229A	5	221A	II	222	I2	225	I	2	2	223	3	240	4	241	5	242	6	34	7	TRX	8	44	9	225	1	2	2	23	3	40	4	41	5	42	6	3X	7	TRX	8	44	9																																																
3X	5	2	I	GRD	2	I25A	4	I29A	5	I27A	6	I21A	II	I22	I2	2	I	GRD	2	225A	3	227A	4	229A	5	221A	II	222	I2	225	I	2	2	223	3	240	4	241	5	242	6	34	7	TRX	8	44	9	225	1	2	2	23	3	40	4	41	5	42	6	3X	7	TRX	8	44	9																																																		
2	I	GRD	2	I25A	4	I29A	5	I27A	6	I21A	II	I22	I2	2	I	GRD	2	225A	3	227A	4	229A	5	221A	II	222	I2	225	I	2	2	223	3	240	4	241	5	242	6	34	7	TRX	8	44	9	225	1	2	2	23	3	40	4	41	5	42	6	3X	7	TRX	8	44	9																																																				
GRD	2	I25A	4	I29A	5	I27A	6	I21A	II	I22	I2	2	I	GRD	2	225A	3	227A	4	229A	5	221A	II	222	I2	225	I	2	2	223	3	240	4	241	5	242	6	34	7	TRX	8	44	9	225	1	2	2	23	3	40	4	41	5	42	6	3X	7	TRX	8	44	9																																																						
I25A	4	I29A	5	I27A	6	I21A	II	I22	I2	2	I	GRD	2	225A	3	227A	4	229A	5	221A	II	222	I2	225	I	2	2	223	3	240	4	241	5	242	6	34	7	TRX	8	44	9	225	1	2	2	23	3	40	4	41	5	42	6	3X	7	TRX	8	44	9																																																								
I29A	5	I27A	6	I21A	II	I22	I2	2	I	GRD	2	225A	3	227A	4	229A	5	221A	II	222	I2	225	I	2	2	223	3	240	4	241	5	242	6	34	7	TRX	8	44	9	225	1	2	2	23	3	40	4	41	5	42	6	3X	7	TRX	8	44	9																																																										
I27A	6	I21A	II	I22	I2	2	I	GRD	2	225A	3	227A	4	229A	5	221A	II	222	I2	225	I	2	2	223	3	240	4	241	5	242	6	34	7	TRX	8	44	9	225	1	2	2	23	3	40	4	41	5	42	6	3X	7	TRX	8	44	9																																																												
I21A	II	I22	I2	2	I	GRD	2	225A	3	227A	4	229A	5	221A	II	222	I2	225	I	2	2	223	3	240	4	241	5	242	6	34	7	TRX	8	44	9	225	1	2	2	23	3	40	4	41	5	42	6	3X	7	TRX	8	44	9																																																														
I22	I2	2	I	GRD	2	225A	3	227A	4	229A	5	221A	II	222	I2	225	I	2	2	223	3	240	4	241	5	242	6	34	7	TRX	8	44	9	225	1	2	2	23	3	40	4	41	5	42	6	3X	7	TRX	8	44	9																																																																
2	I	GRD	2	225A	3	227A	4	229A	5	221A	II	222	I2	225	I	2	2	223	3	240	4	241	5	242	6	34	7	TRX	8	44	9	225	1	2	2	23	3	40	4	41	5	42	6	3X	7	TRX	8	44	9																																																																		
GRD	2	225A	3	227A	4	229A	5	221A	II	222	I2	225	I	2	2	223	3	240	4	241	5	242	6	34	7	TRX	8	44	9	225	1	2	2	23	3	40	4	41	5	42	6	3X	7	TRX	8	44	9																																																																				
225A	3	227A	4	229A	5	221A	II	222	I2	225	I	2	2	223	3	240	4	241	5	242	6	34	7	TRX	8	44	9	225	1	2	2	23	3	40	4	41	5	42	6	3X	7	TRX	8	44	9																																																																						
227A	4	229A	5	221A	II	222	I2	225	I	2	2	223	3	240	4	241	5	242	6	34	7	TRX	8	44	9	225	1	2	2	23	3	40	4	41	5	42	6	3X	7	TRX	8	44	9																																																																								
229A	5	221A	II	222	I2	225	I	2	2	223	3	240	4	241	5	242	6	34	7	TRX	8	44	9	225	1	2	2	23	3	40	4	41	5	42	6	3X	7	TRX	8	44	9																																																																										
221A	II	222	I2	225	I	2	2	223	3	240	4	241	5	242	6	34	7	TRX	8	44	9	225	1	2	2	23	3	40	4	41	5	42	6	3X	7	TRX	8	44	9																																																																												
222	I2	225	I	2	2	223	3	240	4	241	5	242	6	34	7	TRX	8	44	9	225	1	2	2	23	3	40	4	41	5	42	6	3X	7	TRX	8	44	9																																																																														
225	I	2	2	223	3	240	4	241	5	242	6	34	7	TRX	8	44	9	225	1	2	2	23	3	40	4	41	5	42	6	3X	7	TRX	8	44	9																																																																																
2	2	223	3	240	4	241	5	242	6	34	7	TRX	8	44	9	225	1	2	2	23	3	40	4	41	5	42	6	3X	7	TRX	8	44	9																																																																																		
223	3	240	4	241	5	242	6	34	7	TRX	8	44	9	225	1	2	2	23	3	40	4	41	5	42	6	3X	7	TRX	8	44	9																																																																																				
240	4	241	5	242	6	34	7	TRX	8	44	9	225	1	2	2	23	3	40	4	41	5	42	6	3X	7	TRX	8	44	9																																																																																						
241	5	242	6	34	7	TRX	8	44	9	225	1	2	2	23	3	40	4	41	5	42	6	3X	7	TRX	8	44	9																																																																																								
242	6	34	7	TRX	8	44	9	225	1	2	2	23	3	40	4	41	5	42	6	3X	7	TRX	8	44	9																																																																																										
34	7	TRX	8	44	9	225	1	2	2	23	3	40	4	41	5	42	6	3X	7	TRX	8	44	9																																																																																												
TRX	8	44	9	225	1	2	2	23	3	40	4	41	5	42	6	3X	7	TRX	8	44	9																																																																																														
44	9	225	1	2	2	23	3	40	4	41	5	42	6	3X	7	TRX	8	44	9																																																																																																
225	1	2	2	23	3	40	4	41	5	42	6	3X	7	TRX	8	44	9																																																																																																		
2	2	23	3	40	4	41	5	42	6	3X	7	TRX	8	44	9																																																																																																				
23	3	40	4	41	5	42	6	3X	7	TRX	8	44	9																																																																																																						
40	4	41	5	42	6	3X	7	TRX	8	44	9																																																																																																								
41	5	42	6	3X	7	TRX	8	44	9																																																																																																										
42	6	3X	7	TRX	8	44	9																																																																																																												
3X	7	TRX	8	44	9																																																																																																														
TRX	8	44	9																																																																																																																
44	9																																																																																																																		

FIG. 25 – CONNECTION DIAGRAM 3 COMPRESSOR

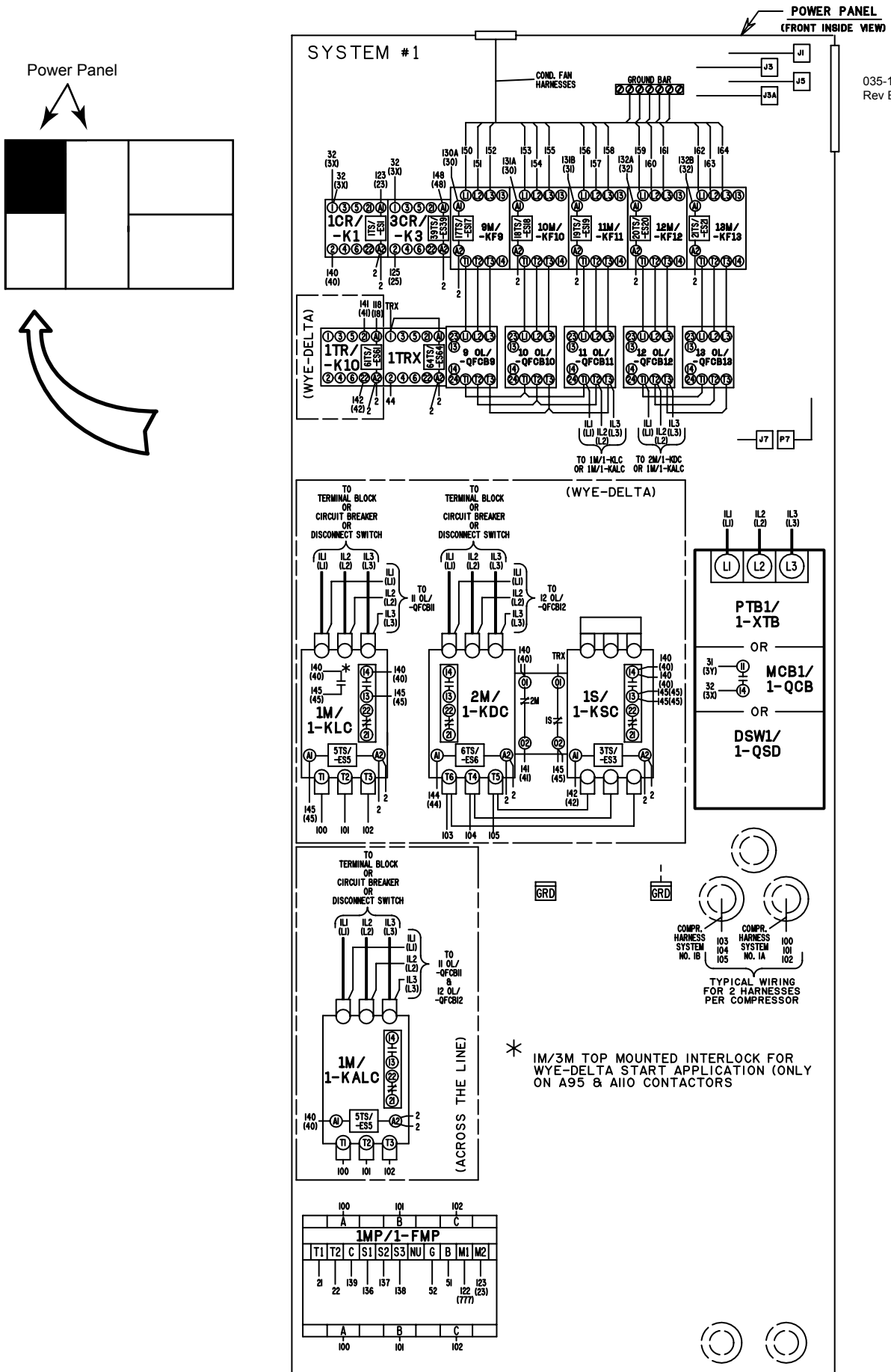

FIG. 26 – CONNECTION DIAGRAM 3 COMPRESSOR POWER PANEL

# CONNECTION WIRING DIAGRAM

035-15937-104  
Rev E

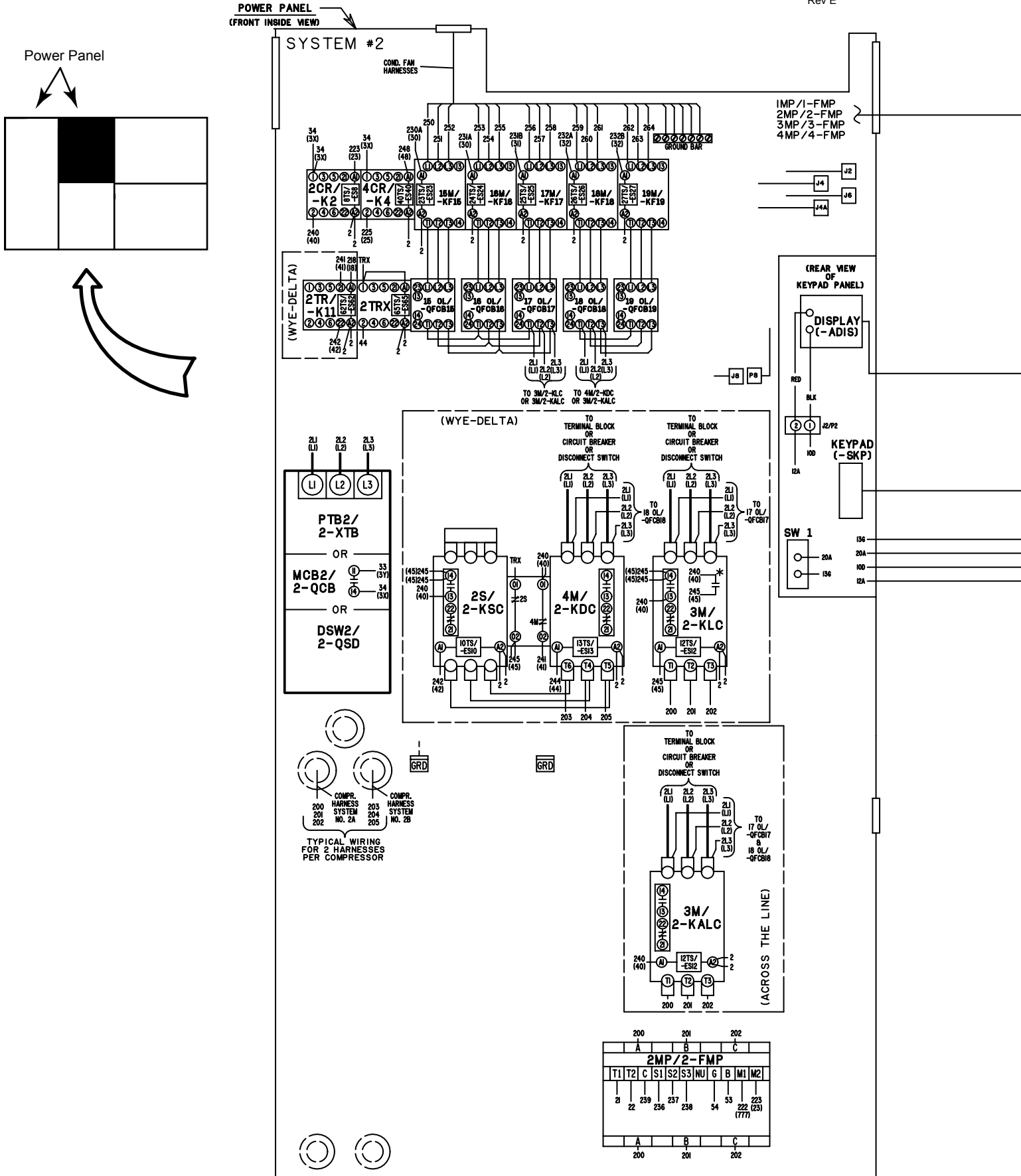
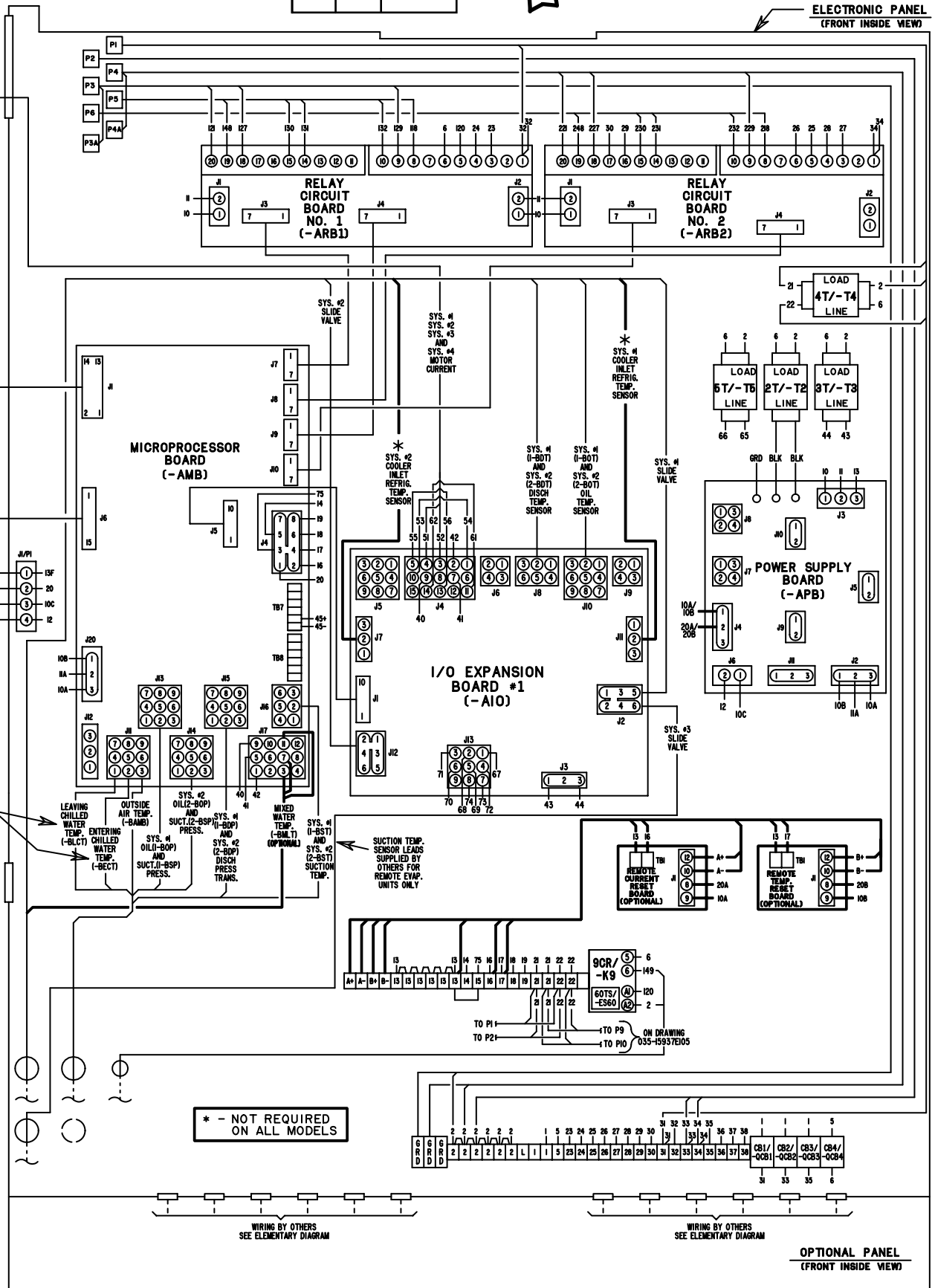
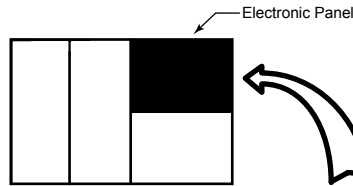

FIG. 27 – CONNECTION DIAGRAM 3 COMPRESSOR POWER PANEL

LD010035



7

## CONNECTION DIAGRAM ELEC. BOX (YCAS0685 - YCAS0965)

### STANDARD AND REMOTE EVAP. UNITS

- J9, JII, JIIA, JI3, JI5, PI5 — POWER PANEL
- P9, PII, PIIA, PI3, — ELECTRONIC (MICRO) PANEL

035-15937E105  
REV. D

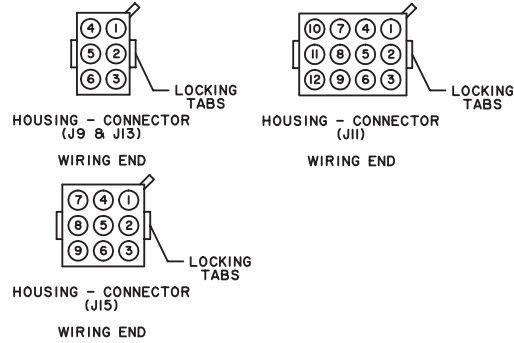

- 5CR & 7CR/ -CONTROL RELAYS
- K5 & -K7
- CB4, CB5, CB6/ -CIRCUIT BREAKERS
- QCB4, -QCB5, -QCB6
- 21CB THRU 26CB -OVERLOAD CIRCUIT BREAKERS (SYS. #3)
- 21 OL THRU 26 OL -MOTOR OVERLOADS (SYS. #3)
- QFCB21 THRU -QFCB26 -MOTOR OVERLOADS W/OVERLOAD CIRCUIT BREAKERS (SYS. #3)
- 3FU, 4FU/ -TRANSFORMER FUSE
- F3, -F4 (OPTIONAL)

LEGEND

- 5M -COMPRESSOR CONTACTORS
- 3-KLC OR 3-KALC
- 6M/ -COMPRESSOR CONTACTORS
- 3-KDC
- 3S/ -COMPRESSOR CONTACTORS
- 3-KSC
- 21M THRU 26M/ -CONDENSER FAN CONTACTORS (SYS. #3)
- KF21 THRU -KF26
- 3MP/3-FMP -MOTOR PROTECTOR (SYS. #3)
- 1T/-T1 -CONTROL TRANSFORMER 2KVA (OPTIONAL)

- 6T, 7T, 8T/ -MICRO PANEL TRANSFORMERS
- T6, -T7, -T8
- 3TR/ -TIMER RELAYS
- K12
- TS/-ES -TRANSIENT SUPPRESSORS
- PTB3/ -POWER TERMINAL BLOCK
- 3-XTB, -MOTOR CIRCUIT BREAKER
- MCB3/
- 3-QCB, -DISCONNECT SERVICE SWITCH
- DSW3/
- 3-QSD, -WIRING BY YORK
- -WIRING BY OTHERS
- -OPTIONAL WIRING AND/OR COMPONENTS

NOTE: I. WIRE NUMBERS IDENTIFIED IN (PARENTHESIS) INDICATE THE ACTUAL HARNESS CODE STAMPED ON THE WIRE.

PLUG NO.	WIRE NO.	PLUG PIN NO.
P9	2I	1
	2	2
	22	3
	35	4
	36	5

PLUG NO.	WIRE NO.	PLUG PIN NO.
PII	2	1
	GRD	2
	325	3
	329	5
	327	4
	32I	11
	322	12

PLUG NO.	WIRE NO.	PLUG PIN NO.
PI3	330	1
	33I	2
	332	3
	348	4
	318	6

PLUG NO.	WIRE NO.	PLUG PIN NO.
PI5	325	1
	2	2
	323	3
	340	4
	34I	5
	342	6
	32	7
	TRX	8
	44	9

PLUG NO.	WIRE NO.	PLUG PIN NO.
J9	2I	1
	2	2
	22	3
	3Y	4
3X	5	

PLUG NO.	WIRE NO.	PLUG PIN NO.
JII	2	1
	GRD	2
	325A	3
	329A	5
	327A	4
	32IA	11
	322	12

PLUG NO.	WIRE NO.	PLUG PIN NO.
JI3	30	1
	3I	2
	32	3
	48	4
	18	6

PLUG NO.	WIRE NO.	PLUG PIN NO.
JI5	25	1
	2	2
	23	3
	40	4
	4I	5
	42	6
	3X	7
	TRX	8
	44	9

PLUG NO.	WIRE NO.	PLUG PIN NO.
PIIA	325	1
	322	2

PLUG NO.	WIRE NO.	PLUG PIN NO.
JIIA	25	1
	777	2

FIG. 28 – CONNECTION DIAGRAM 3 COMPRESSOR POWER PANEL

LD010039

# CONNECTION WIRING DIAGRAM

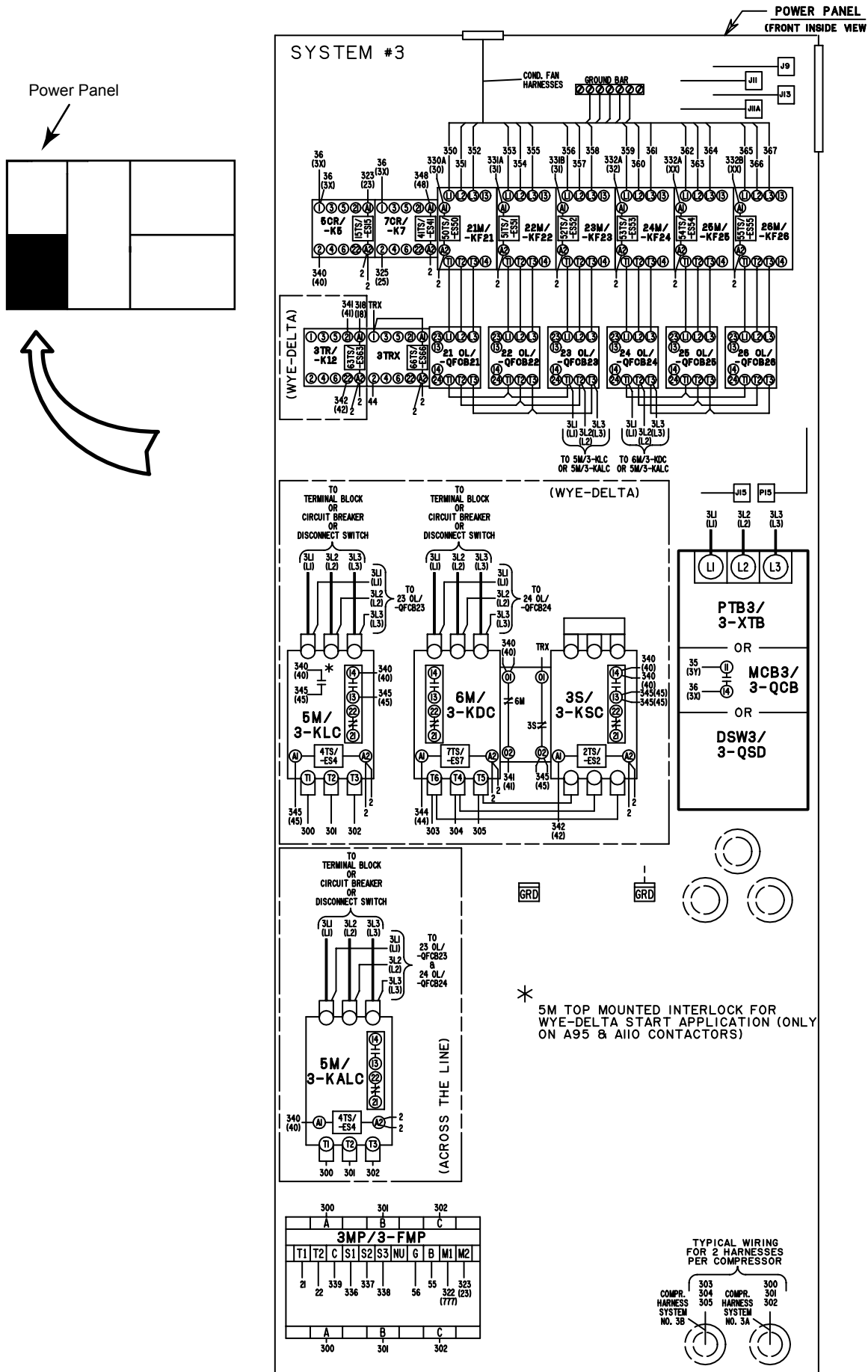

035 15937 105  
Rev D

7

FIG. 29 – CONNECTION DIAGRAM 3 COMPRESSOR ELECTRONIC PANEL

LD010037

# CONNECTION DIAGRAM ELEC. BOX (YCAS0685 - YCAS0965)

035-15937-105  
Rev D

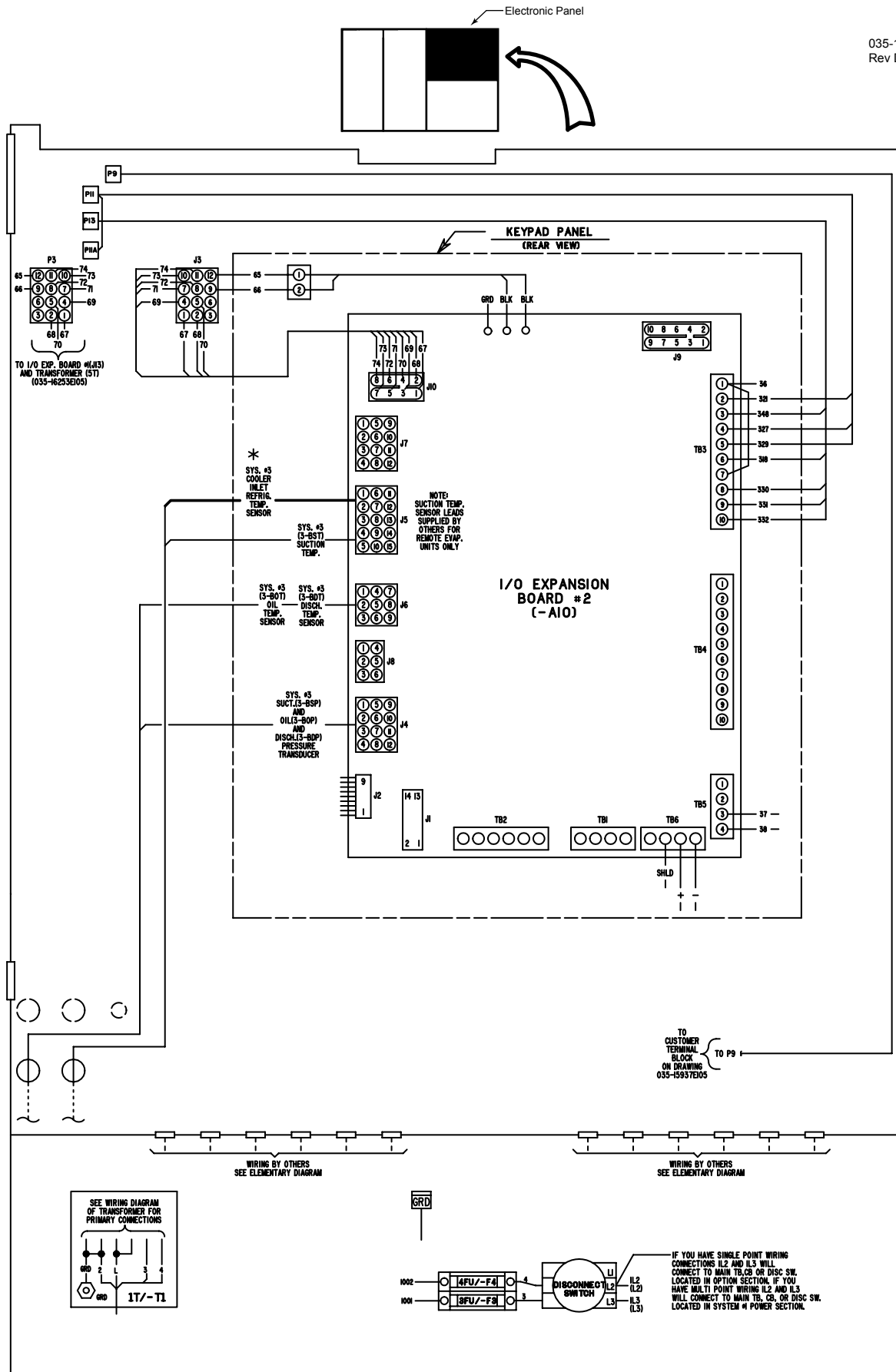

FIG. 30 – ELEMENTARY DIAGRAM 3 COMPRESSOR DXST DIRECT DRIVE CONTROL CIRCUIT

LD010038

# ELEMENTARY DIAGRAM DXST DRIVE CONTROL CIRCUIT

035 15937 102  
REV. D

**NOTES:**

1. FIELD WIRING TO BE IN ACCORDANCE WITH THE CURRENT EDITION OF THE NATIONAL ELECTRICAL CODE AS WELL AS ALL OTHER APPLICABLE CODES AND SPECIFICATIONS.
2. CONTACTS MUST BE SUITABLE FOR SWITCHING 24VDC, (GOLD CONTACTS RECOMMENDED). WIRING SHALL NOT BE RUN IN THE SAME CONDUIT WITH ANY LINE VOLTAGE WIRING.
3. TO CYCLE UNIT ON AND OFF AUTOMATICALLY WITH CONTACT SHOWN, INSTALL A CYCLING DEVICE IN SERIES WITH THE FLOW SWITCH (FLSW). SEE NOTE 2 FOR CONTACT RATING AND WIRING SPECIFICATIONS.
4. TO STOP UNIT (EMERGENCY STOP) WITH CONTACTS OTHER THAN THOSE SHOWN, INSTALL THE STOP CONTACT BETWEEN TERMINALS 5 AND 1. IF A STOP DEVICE IS NOT INSTALLED, A JUMPER MUST BE CONNECTED BETWEEN TERMINALS 5 AND 1. DEVICE MUST HAVE A MINIMUM CONTACT RATING OF 100VA AT 115VOLTS A.C.
5. ALARM CONTACTS ARE FOR ANNUNCIATING ALARM/UNIT MALFUNCTION. CONTACTS ARE RATED AT 115V, 100VA, RESISTIVE LOAD ONLY, AND MUST BE SUPPRESSED AT LOAD BY USER.
6. SEE INSTALLATION, OPERATION AND MAINTENANCE MANUAL WHEN OPTIONAL EQUIPMENT IS USED.
7. JUMPER MUST BE INSTALLED FOR THREE COMPRESSOR OPERATION.

**LEGEND**

- TS TRANSIENT VOLTAGE SUPPRESSION
- ◻ TERMINAL BLOCK FOR CUSTOMER CONNECTIONS
- ◻ TERMINAL BLOCK FOR CUSTOMER LOW VOLTAGE (CLASS 2) CONNECTIONS. SEE NOTE 2.
- ◻ TERMINAL BLOCK FOR YORK CONNECTIONS ONLY
- WIRING AND COMPONENTS BY YORK
- - - OPTIONAL EQUIPMENT
- - - WIRING AND/OR COMPONENTS BY OTHERS

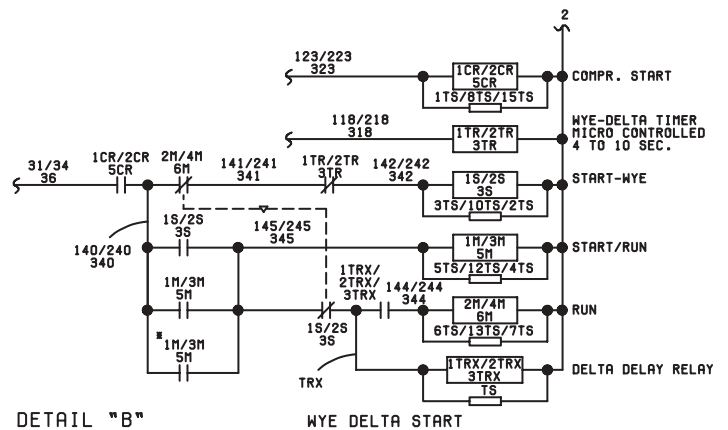
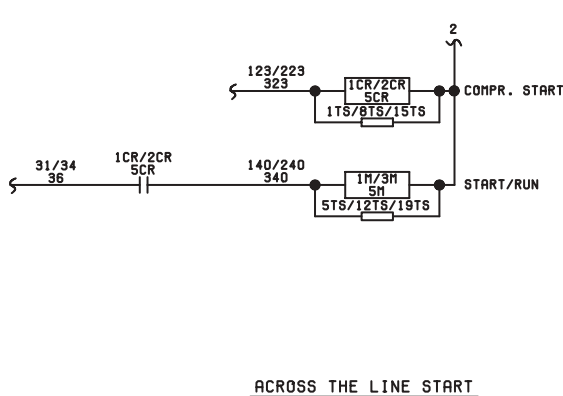
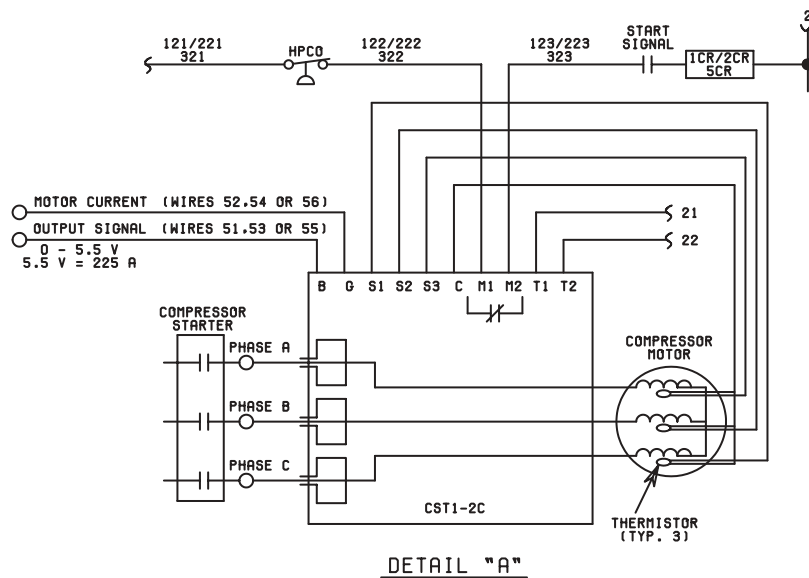

■ INTERLOCK ON TOP MOUNTED RELAY, WYE-DELTA ONLY ON A95 & A110 CONTACTORS)

**FIG. 31 – ELEMENTARY DIAGRAM DXST DIRECT DRIVE - 3 COMPRESSOR**

## ELEMENTARY WIRING DIAGRAM (CONT'D)

035 15937 102  
REV. D

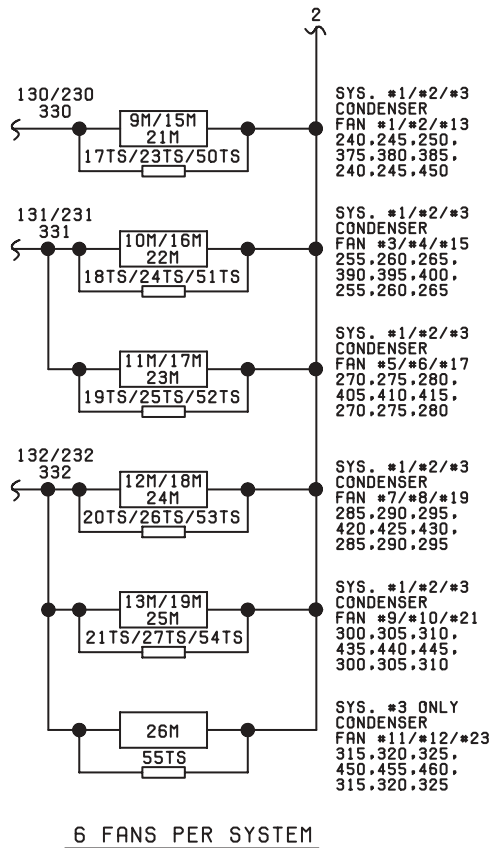
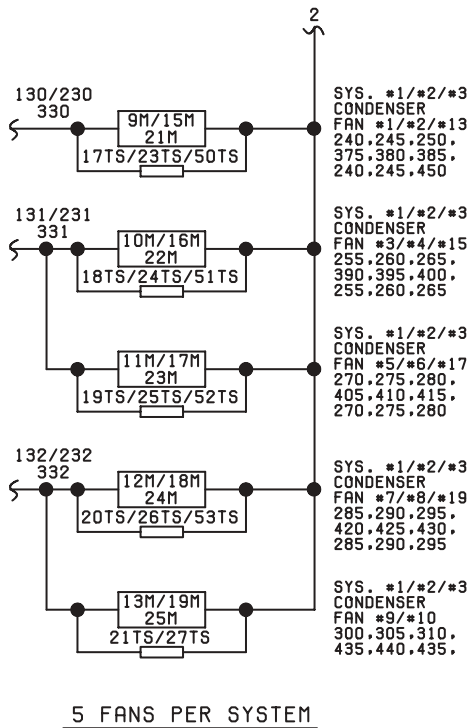
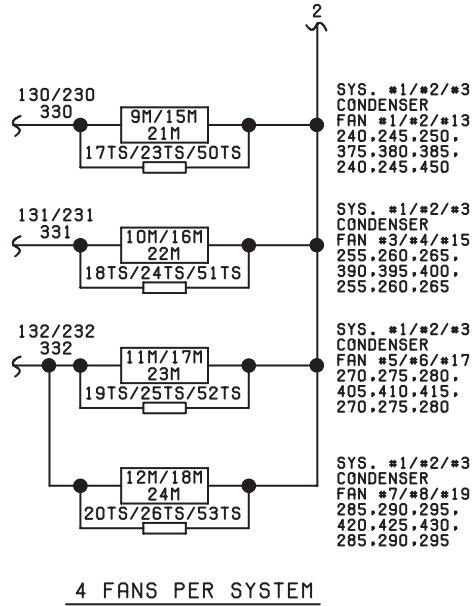
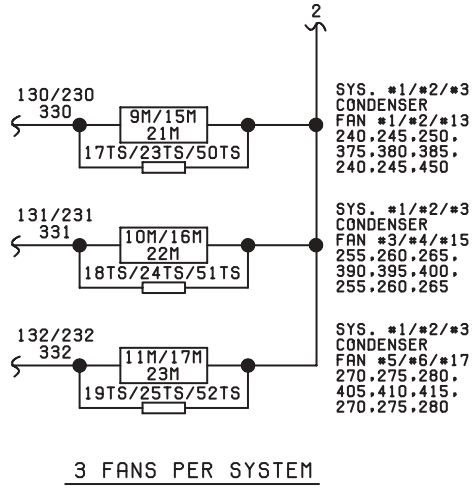

### DETAIL "C"

SEE ENGINEER GUIDE OR INSTALLATION, OPERATION AND MAINTENANCE  
MANUAL FOR JUMPER OF CONDENSER FANS FOR CHILLER MODEL.

FIG. 32 – ELEMENTARY DIAGRAM SYSTEM WIRING 3 COMPRESSOR

# CONNECTION DIAGRAM SYSTEM WIRING (YCAS0685 - YCAS0965)

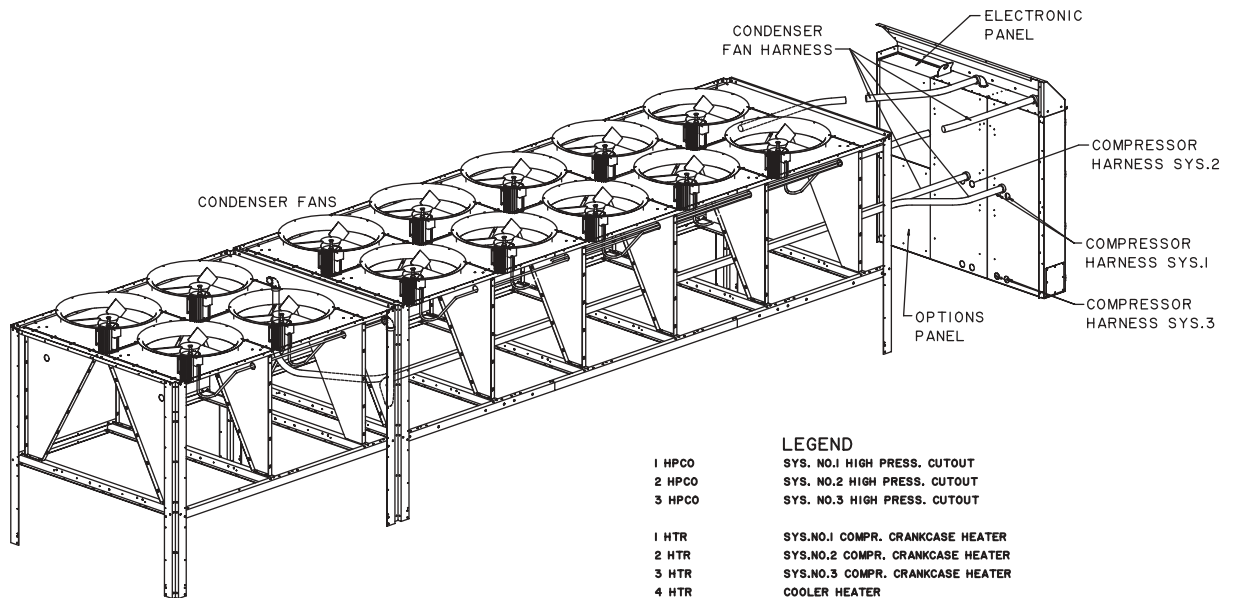
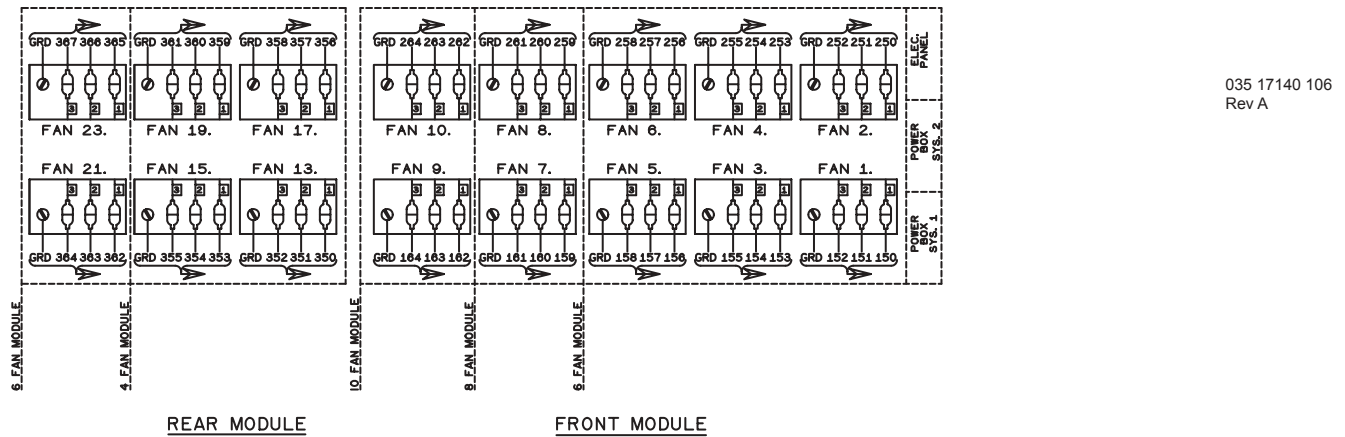

- LEGEND**
- 1 HPCO      SYS.NO.1 HIGH PRESS. CUTOUT
  - 2 HPCO      SYS.NO.2 HIGH PRESS. CUTOUT
  - 3 HPCO      SYS.NO.3 HIGH PRESS. CUTOUT
  
  - 1 HTR        SYS.NO.1 COMPR. CRANKCASE HEATER
  - 2 HTR        SYS.NO.2 COMPR. CRANKCASE HEATER
  - 3 HTR        SYS.NO.3 COMPR. CRANKCASE HEATER
  - 4 HTR        COOLER HEATER
  
  - 1 LLSV        SYS.NO.1 LIQUID LINE SOLENIOD VALVE (UNIT IDENT)
  - 2 LLSV        SYS.NO.2 LIQUID LINE SOLENIOD VALVE (UNIT IDENT)
  - 3 LLSV        SYS.NO.3 LIQUID LINE SOLENIOD VALVE (UNIT IDENT)
  
  - TXV 1        SYS.NO.1 THERMAL EXPANSION VALVE (UNIT IDENT)
  - TXV 2        SYS.NO.2 THERMAL EXPANSION VALVE (UNIT IDENT)
  - TXV 3        SYS.NO.3 THERMAL EXPANSION VALVE (UNIT IDENT)

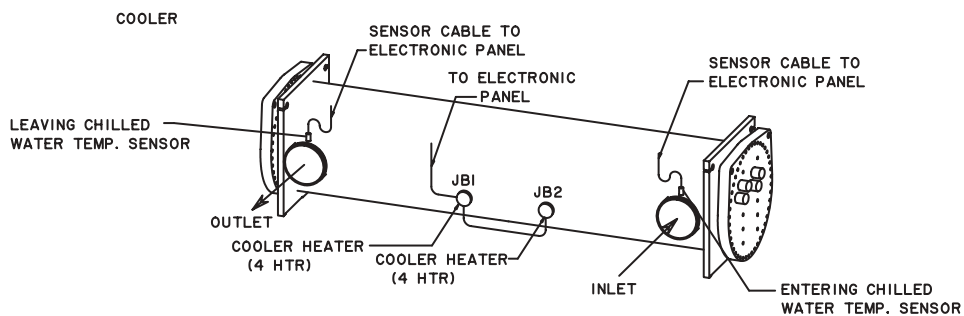

7

**FIG. 33 – CONNECTION DIAGRAM STSTEM WIRING - 3 COMPRESSOR**

# CONNECTION DIAGRAM SYSTEM WIRING

COMPRESSORS  
(SYSTEMS 1,2,3)

035 17140 106  
Rev A

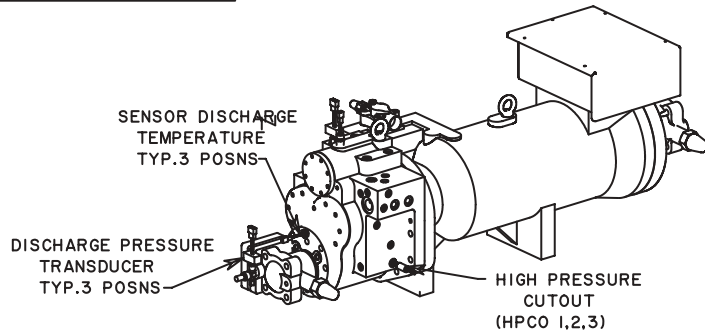
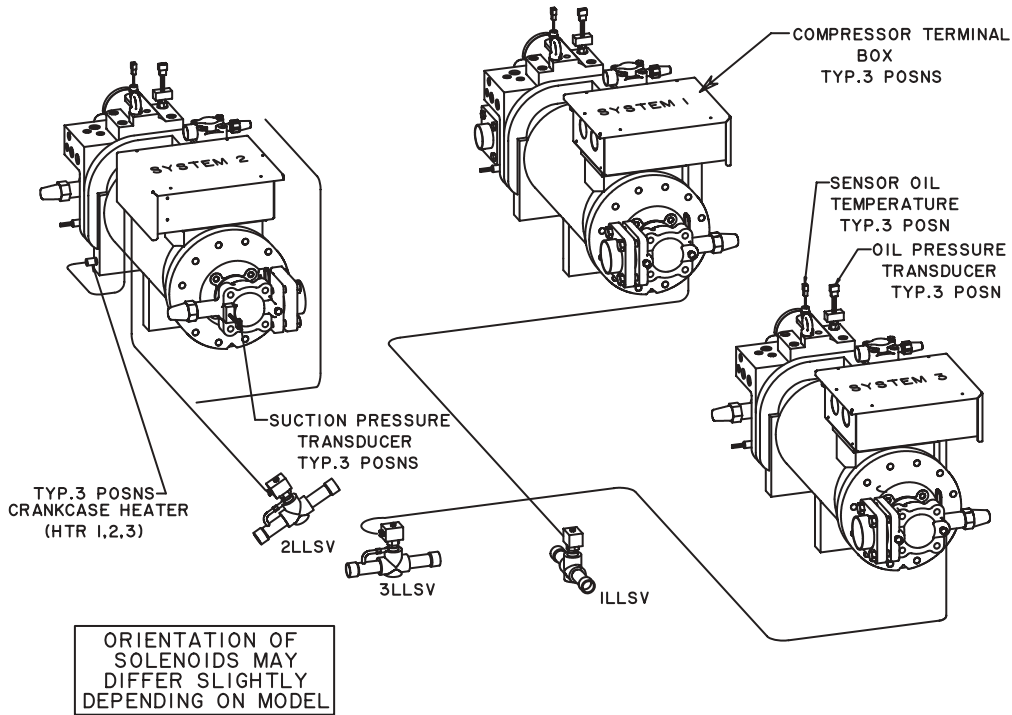

SYSTEM 1  
COMPRESSOR TERMINAL BOX  
ACROSS THE LINE  
USE (XXX) FOR WYE-DELTA-START

SEE SAFTY RELIEF DEVICE KIT FOR  
WIRING OF RELIEF DEVICES IN CMTB  
JUMPERS ONLY REQUIRED ON  
ACROSS THE LINE UNITS

SYSTEM 2  
COMPRESSOR TERMINAL BOX  
ACROSS THE LINE  
USE (XXX) FOR WYE-DELTA-START

SYSTEM 3  
COMPRESSOR TERMINAL BOX  
ACROSS THE LINE  
USE (XXX) FOR WYE-DELTA-START

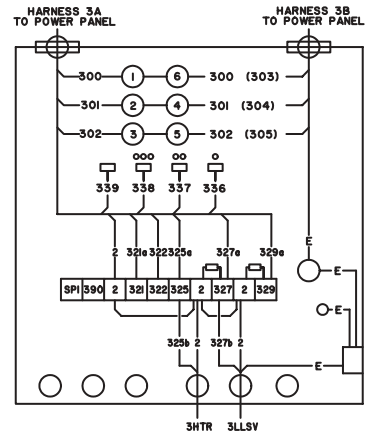
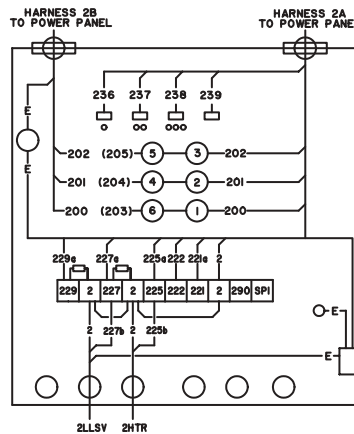
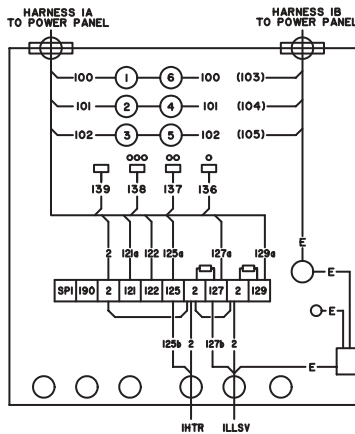

LD010043

FIG. 34 – CONNECTION DIAGRAM STSTEM WIRING - 3 COMPRESSOR

# ELEMENTARY WIRING DIAGRAM YCAS1065 - YCAS1215 (4 COMPRESSOR)

## ELEMENTARY DIAGRAM DXST DIRECT DRIVE POWER CIRCUIT

035-16253E103  
REV. A

--- INDICATES CUSTOMER WIRING  
OPTIONAL EQUIPMENT SEE NOTE 6 ON DWG. 035-16253D102

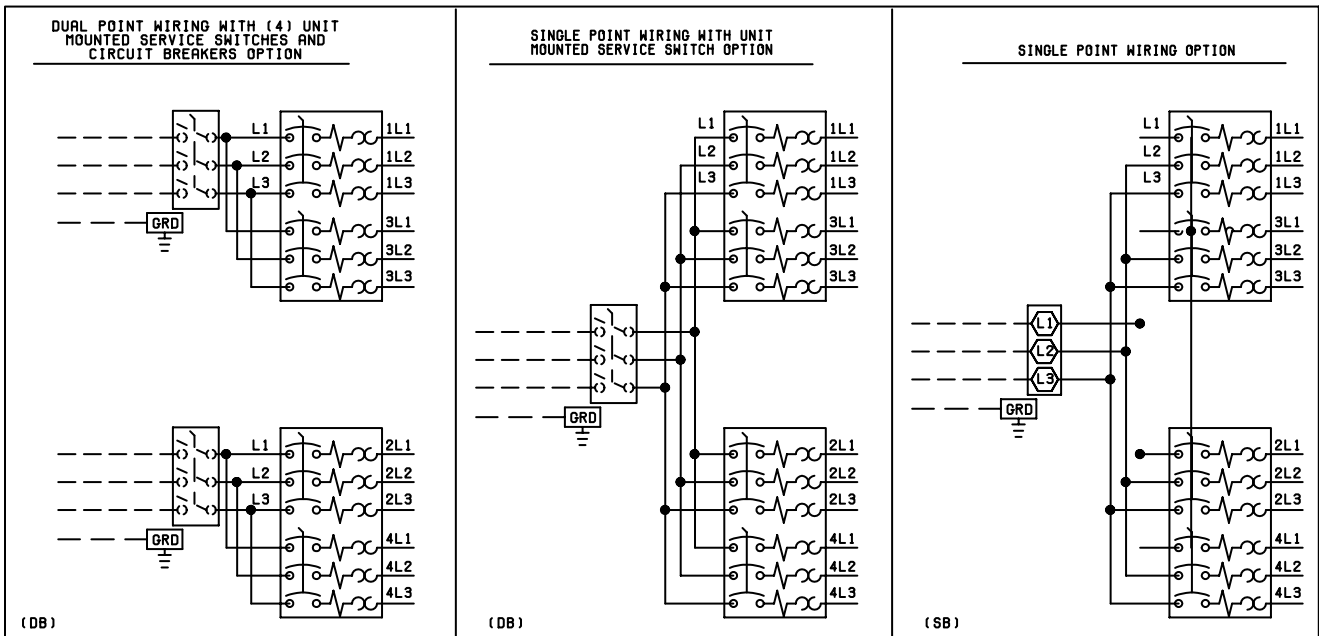
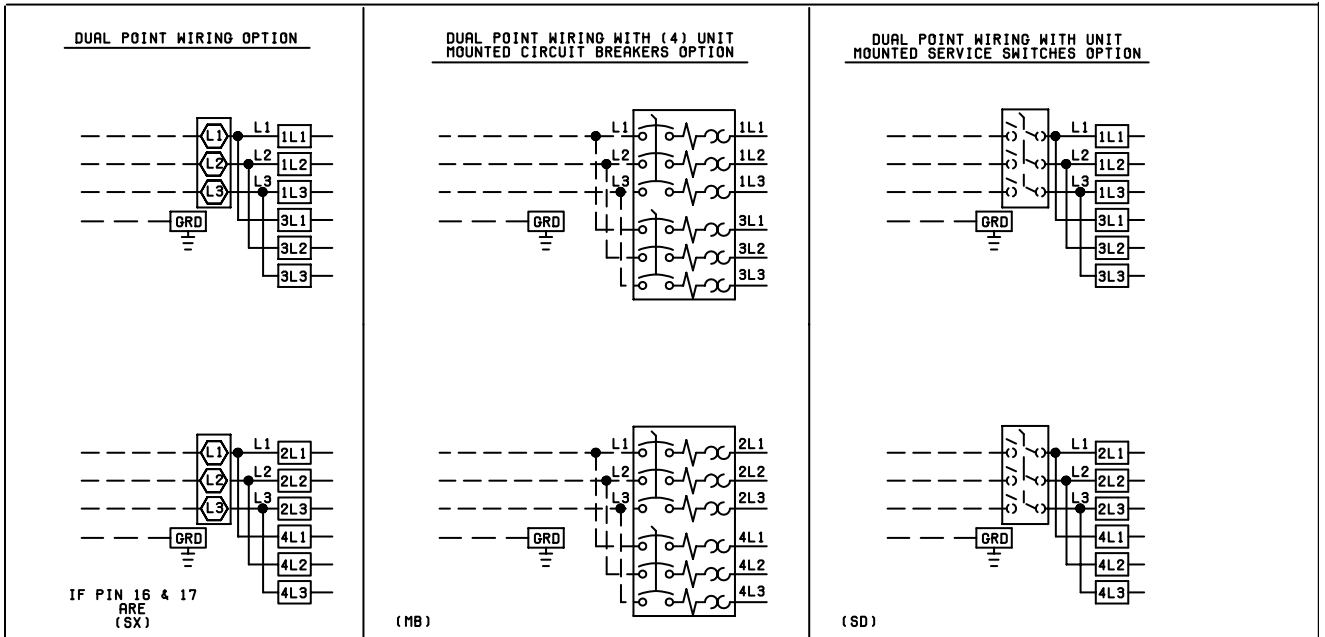

7

FIG. 35 – ELEMENTARY WIRING DIAGRAM - ACROSS-THE-LINE START

# ELEMENTARY WIRING DIAGRAM YCAS1065 - YCAS1215 (4 COMPRESSOR)

035 16253 103  
Rev A

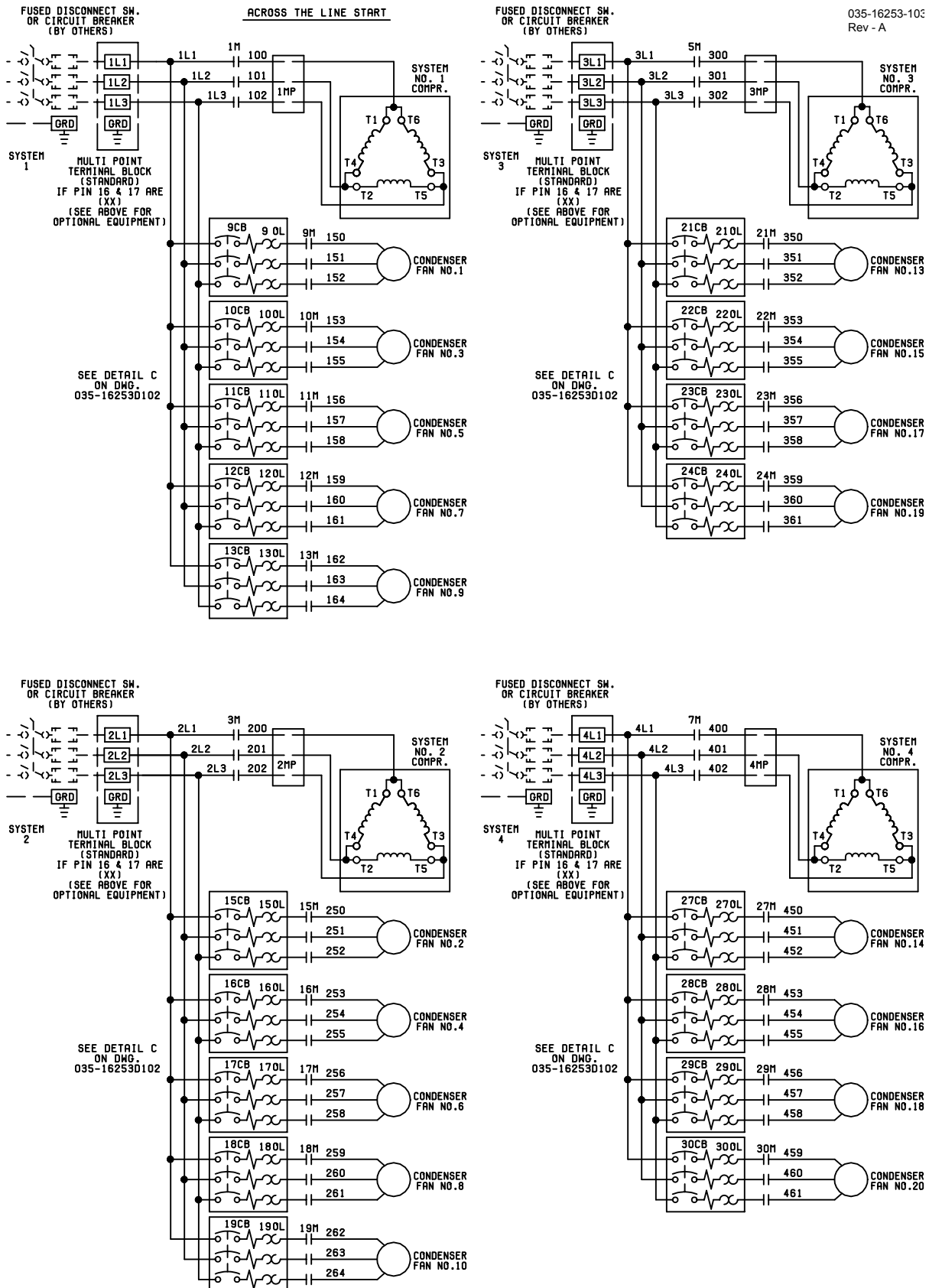

FIG. 36 – ELEMENTARY WIRING DIAGRAM - WYE DELTA START

# ELEMENTARY WIRING DIAGRAM YCAS1065 - YCAS1215 (4 COMPRESSOR)

035 16253 103  
Rev A

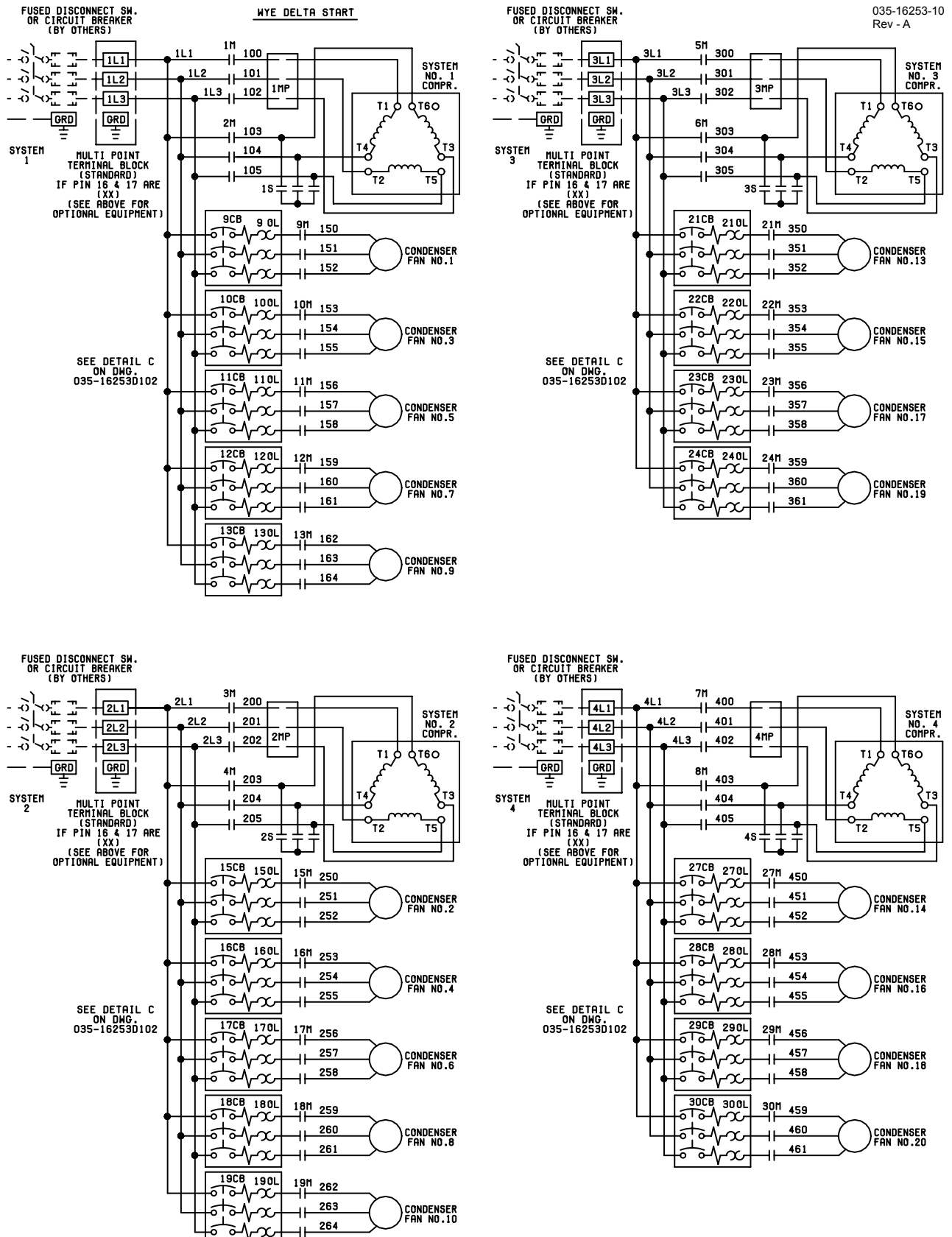







FIG. 37 – CONTROL POWER TRANSFORMER KIT

# ELEMENTARY WIRING DIAGRAM (YCAS1065 - YCAS1215) ACROSS-THE-LINE START AND WYE-DELTA START

**NOTES:**

1. Field wiring to be in accordance with the current edition of the National Electrical Code as well as all other applicable codes and specifications.
2. Contacts must be suitable for switching 24VDC, (Gold contacts recommend). Wiring shall not be run in the same conduit with any line voltage wiring.
3. To cycle the unit on and off automatically with contact shown, install a cycling device in series with the flow switch (FLSW). See note 2 for contact rating and wiring specifications.
4. To stop unit (Emergency Stop) with contacts other than those shown, install the stop contact between terminals 5 and 1. If a stop device is not installed, a jumper must be connected between terminals 5 and 1. Device must have a minimum contact rating of 100A at 115 volts A.C.
5. Alarm contacts are for annunciating alarm/unit malfunction. Contacts are rated at 115V, 100VA, load only, and must be suppressed at load by user.
6. See Installation, Operation and Maintenance Manual when optional equipment is used.

**LEGEND**

TS	Transient Voltage Suppression
	Terminal Block for Customer Connections
	Terminal Block for Customer Low Voltage (Class 2) Connections. See Note 2
	Terminal Block for YORK Connections Only
	Wiring and Components by YORK
	Optional Equipment
	Wiring and/or Components by Others

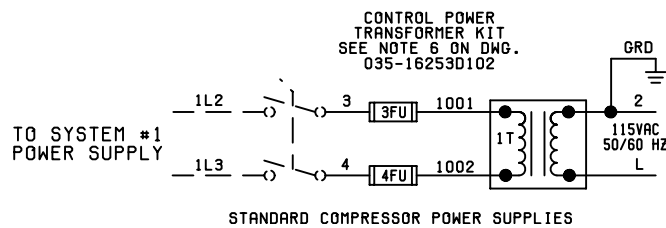

035-16253-103  
Rev A

035-16253-103  
Rev - A

LD09368

**FIG. 38 – ELEMENTARY WIRING DIAGRAM**

This page intentionally left blank.

# ELEMENTARY WIRING DIAGRAM YCAS1065 - YCAS1215 (4 COMPRESSOR)

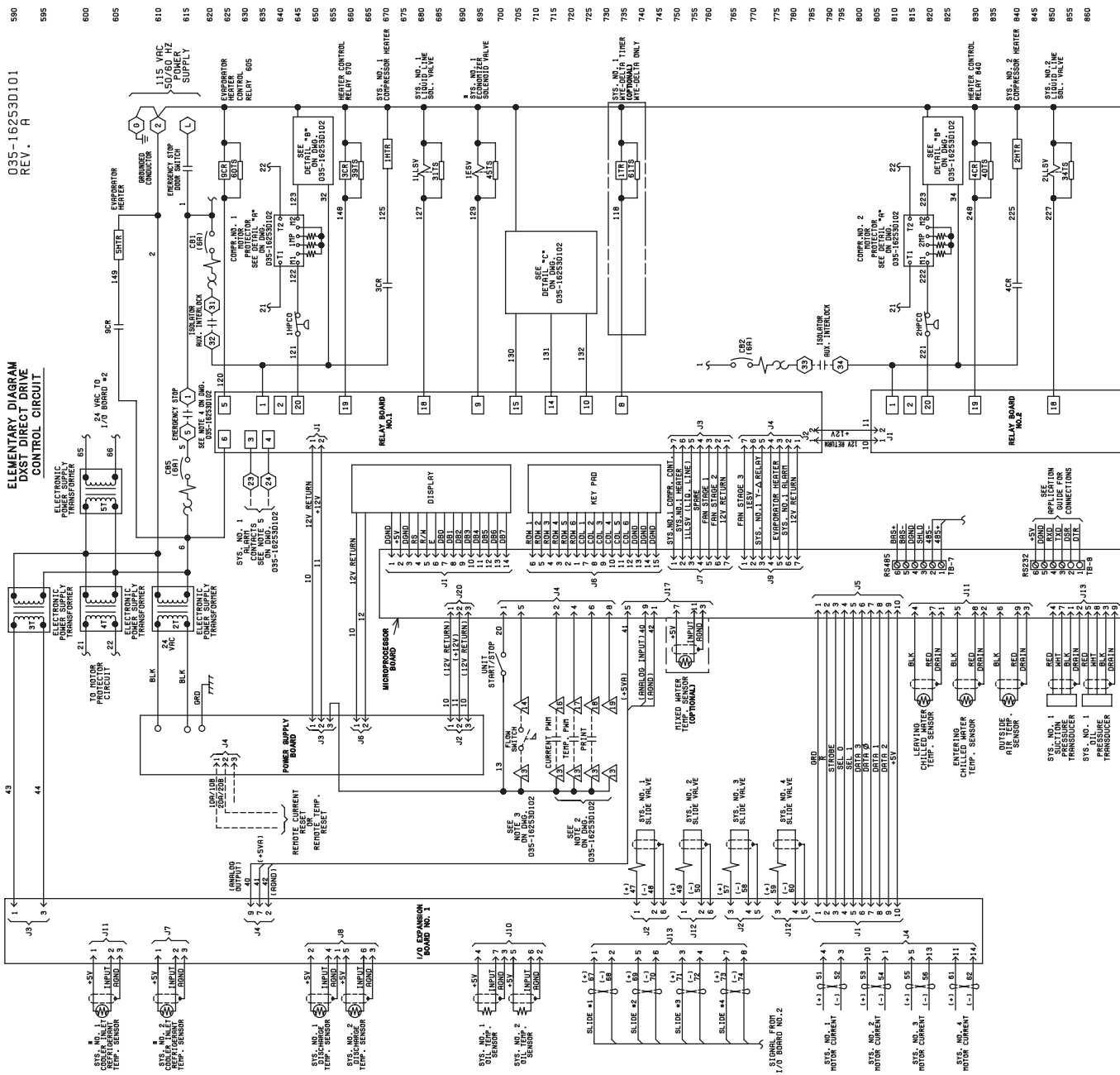

FIG. 39 – ELEMENTARY DIAGRAM 4 COMPRESSOR

**CAUTION:**

No Controls (relays, etc.) should be mounted in the Smart Panel enclosure or connected to power supplies in the control panel. Additionally, control wiring not connected to the Smart Panel should not be run through the cabinet. This could result in nuisance faults.

**CAUTION:**

Any inductive devices (relays) wired in series with the flow switch for start/stop, into the Alarm circuitry, or pilot relays for pump starters wired through motor contactor auxiliary contacts must be suppressed with YORK P/N 031-00808-000 suppressor across the relay/contactor coil.

Any contacts connected to flow switch inputs or BAS inputs on terminals 13 - 19 or TB3, or any other terminals, must be suppressed with a YORK P/N 031-00808-000 suppressor across the relay/contactor coil.

**CAUTION:**

Control wiring connected to the control panel should never be run in the same conduit with power wiring.

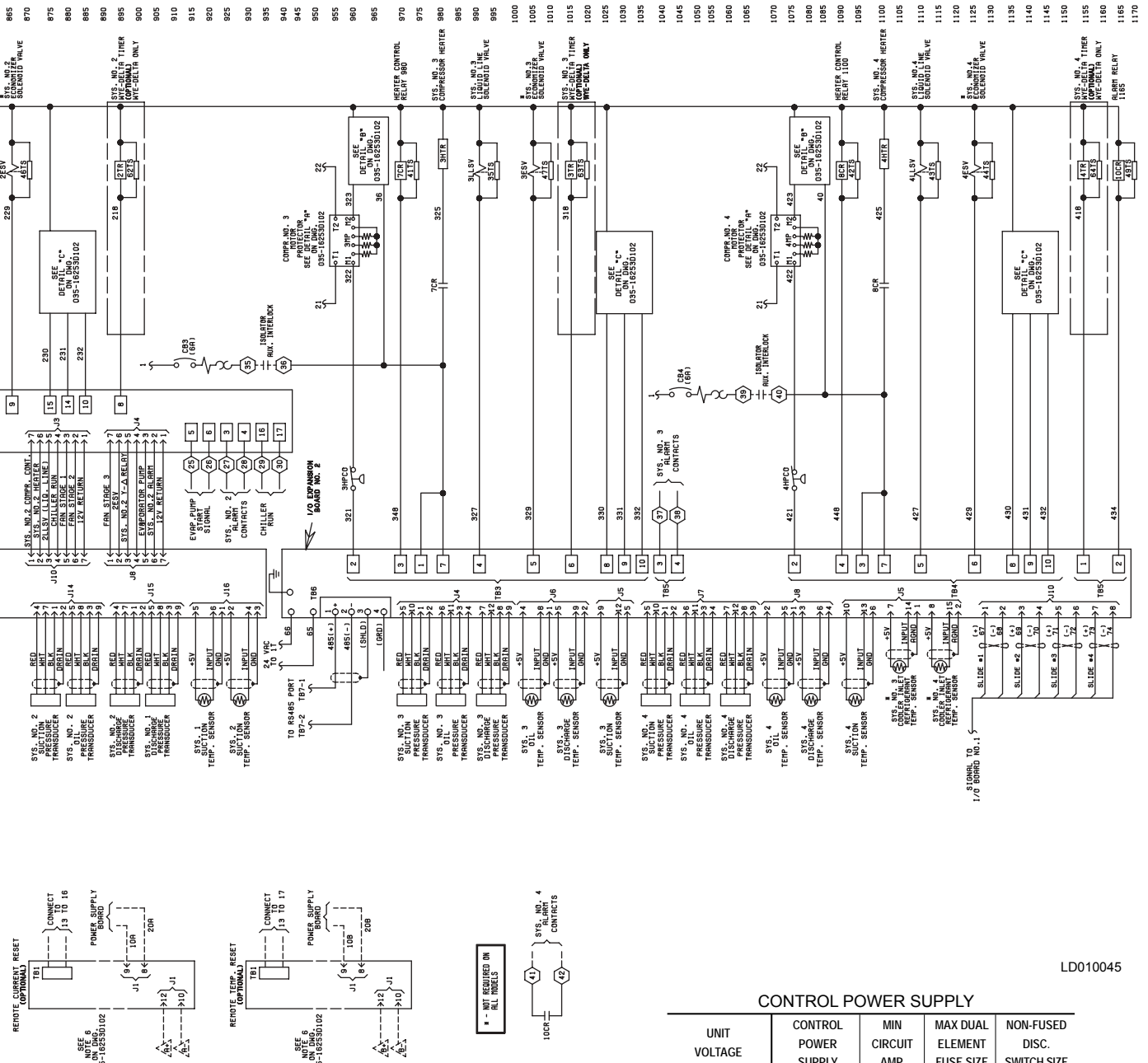

LD010045

**CONTROL POWER SUPPLY**

UNIT VOLTAGE	CONTROL POWER SUPPLY	MIN CIRCUIT AMP.	MAX DUAL ELEMENT FUSE SIZE	NON-FUSED DISC. SWITCH SIZE
ALL MODELS W/O TRANS.	115-1-50/60	20A	20A 250V	30A 240V
MODELS WITH TRANS.	-17 -28 -46 -58	200-1-60 15A 15A 8A 8A	15A 250V 15A 250V 8A 600V 8A 600V	30A 240V 30A 240V 30A 480V 30A 600V

\* All primary and secondary wiring between transformer and control panel included.

**FIG. 40 – ELEMENTARY DIAGRAM 4 COMPRESSOR**

# CONNECTION DIAGRAM ELEC. BOX (YCAS1065 - YCAS1215)

## CONNECTION DIAGRAM. ELEC. BOX STANDARD AND REMOTE EVAP. UNITS

J1, J2, J3, J3A, J4, J4A, — POWER PANEL  
J5, J6, J7, J8, P7 & P8

P1, P2, P3, P3A, — ELECTRONIC (MICRO) PANEL  
P4, P4A, P5, & P6

NOTE: 1. WIRE NUMBERS IDENTIFIED IN  
(PARENTHESIS) INDICATE THE  
ACTUAL HARNESS CODE STAMPED  
ON THE WIRE.

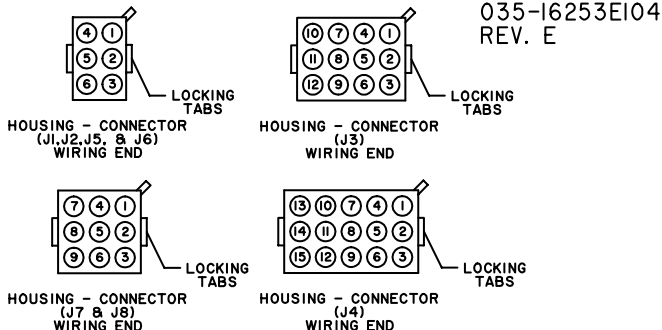

- 1CR THRU 4CR, 9CR/ -CONTROL RELAYS
- K1 THRU -K4, -K9
- CB1, CB2, CB3/ -CIRCUIT BREAKERS
- QCB1, -QCB2, -QCB3
- 9CB THRU 13CB -OVERLOAD CIRCUIT BREAKERS (SYS. #1)
- 15CB THRU 19CB -OVERLOAD CIRCUIT BREAKERS (SYS. #2)
- 9 OL THRU 13 OL -MOTOR OVERLOADS (SYS. #1)
- 15 OL THRU 19 OL -MOTOR OVERLOADS (SYS. #2)
- QFCB9 THRU -QFCB13 -MOTOR OVERLOADS W/OVERLOAD CIRCUIT BREAKERS (SYS. #1)
- QFCB15 THRU -QFCB19 -MOTOR OVERLOADS W/OVERLOAD CIRCUIT BREAKERS (SYS. #2)

### LEGEND

- 1M, 3M/ -COMPRESSOR CONTACTORS
- 1-KLC OR 1-KALC, 2-KLC OR 2-KALC
- 2M, 4M/ -COMPRESSOR CONTACTORS
- 1-KDC, 2-KDC
- 1S, 2S/ -COMPRESSOR CONTACTORS
- 1-KSC, 2-KSC
- 9M THRU 13M/ -CONDENSER FAN CONTACTORS
- KF9 THRU -KF13 (SYS. #1)
- 15M THRU 19M/ -CONDENSER FAN CONTACTORS
- KF15 THRU -KF19 (SYS. #2)
- 1MP/1-FMP -MOTOR PROTECTOR (SYS. #1)
- 2MP/2-FMP -MOTOR PROTECTOR (SYS. #2)

- 2T, 3T, 4T/ -MICRO PANEL TRANSFORMERS
- T2, -T3, -T4
- 1TR, 2TR/ -TIMER RELAYS
- K10, -K11
- TS/-ES -TRANSIENT SUPPRESSORS
- PTB1, PTB2/ -POWER TERMINAL BLOCK
- 1-XTB, 2-XTB
- MCB1, MCB2/ -MOTOR CIRCUIT BREAKER
- 1-QCB, 2-QCB
- DSW1, DSW2/ -DISCONNECT SERVICE SWITCH
- 1-QSD, 2-QSD
- -WIRING BY YORK
- -WIRING BY OTHERS
- -OPTIONAL WIRING AND/OR COMPONENTS

PLUG NO.	WIRE NO.	PLUG PIN NO.	PLUG NO.	WIRE NO.	PLUG PIN NO.	PLUG NO.	WIRE NO.	PLUG PIN NO.	PLUG NO.	WIRE NO.	PLUG PIN NO.	PLUG NO.	WIRE NO.	PLUG PIN NO.	PLUG NO.	WIRE NO.	PLUG PIN NO.
P1	21	1	P2	21	1	P3	2	1	P4	2	1	P5	130	1	P6	230	1
	2	2		2	2		GRD	2		GRD	2		131	2		231	2
	22	3		22	3		125	4		225	3		132	3		232	3
	31	4		33	4		129	5		227	4		148	4		248	4
	32	5		34	5		127	6		229	5		118	6		218	6
J1	21	1	J2	21	1	J3	2	1	J4	2	1	J5	30	1	J6	30	1
	2	2		2	2		GRD	2		GRD	2		31	2		31	2
	22	3		22	3		125A	4		225A	3		32	3		32	3
	3Y	4		3Y	4		129A	5		227A	4		48	4		48	4
	3X	5		3X	5		127A	6		229A	5		18	6		18	6
P3A	125	1	P4A	225	1	J7	25	1	J8	25	1	J7	25	1	J8	25	1
	122	2		222	2		777	2		777	2		2	2		2	2
J3A	25	1	J4A	25	1	J7	23	3	J8	23	3	J7	40	4	J8	40	4
	777	2		777	2		41	5		41	5		41	5		41	5
				42	6		42	6		42	6		42	6			
				3X	7		3X	7		3X	7		3X	7			
				TRX	8		TRX	8		TRX	8		TRX	8			
		44	9	44	9	44	9	44	9								

FIG. 41 – CONNECTION WIRING DIAGRAM

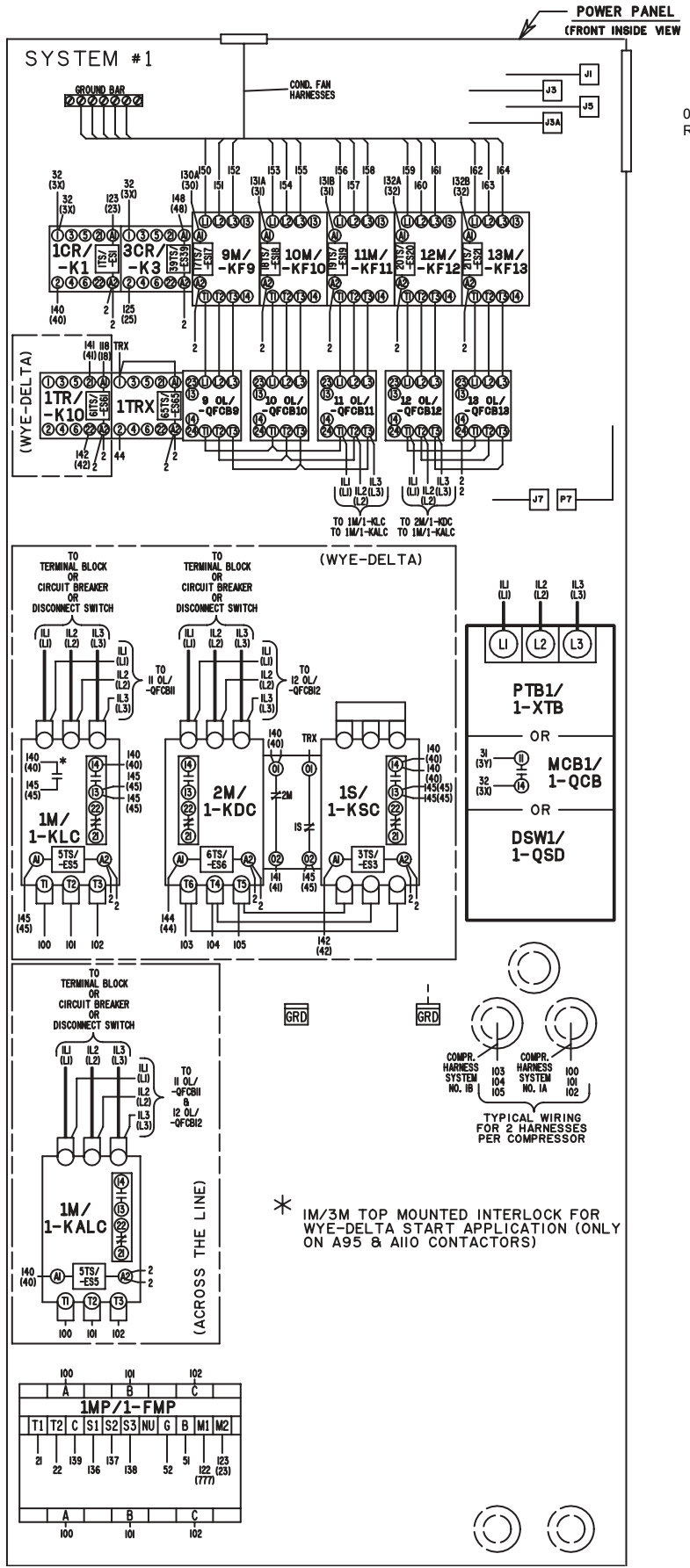
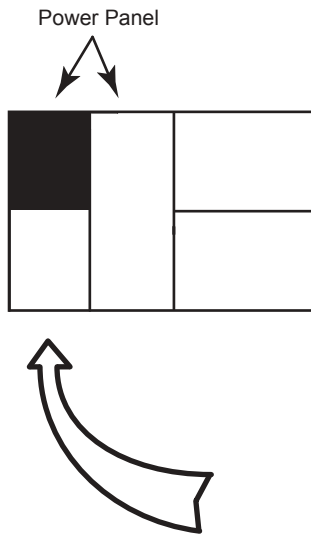

035-16253-104  
Rev D

LD10047



# CONNECTION WIRING DIAGRAM

035-16253-104  
Rev E

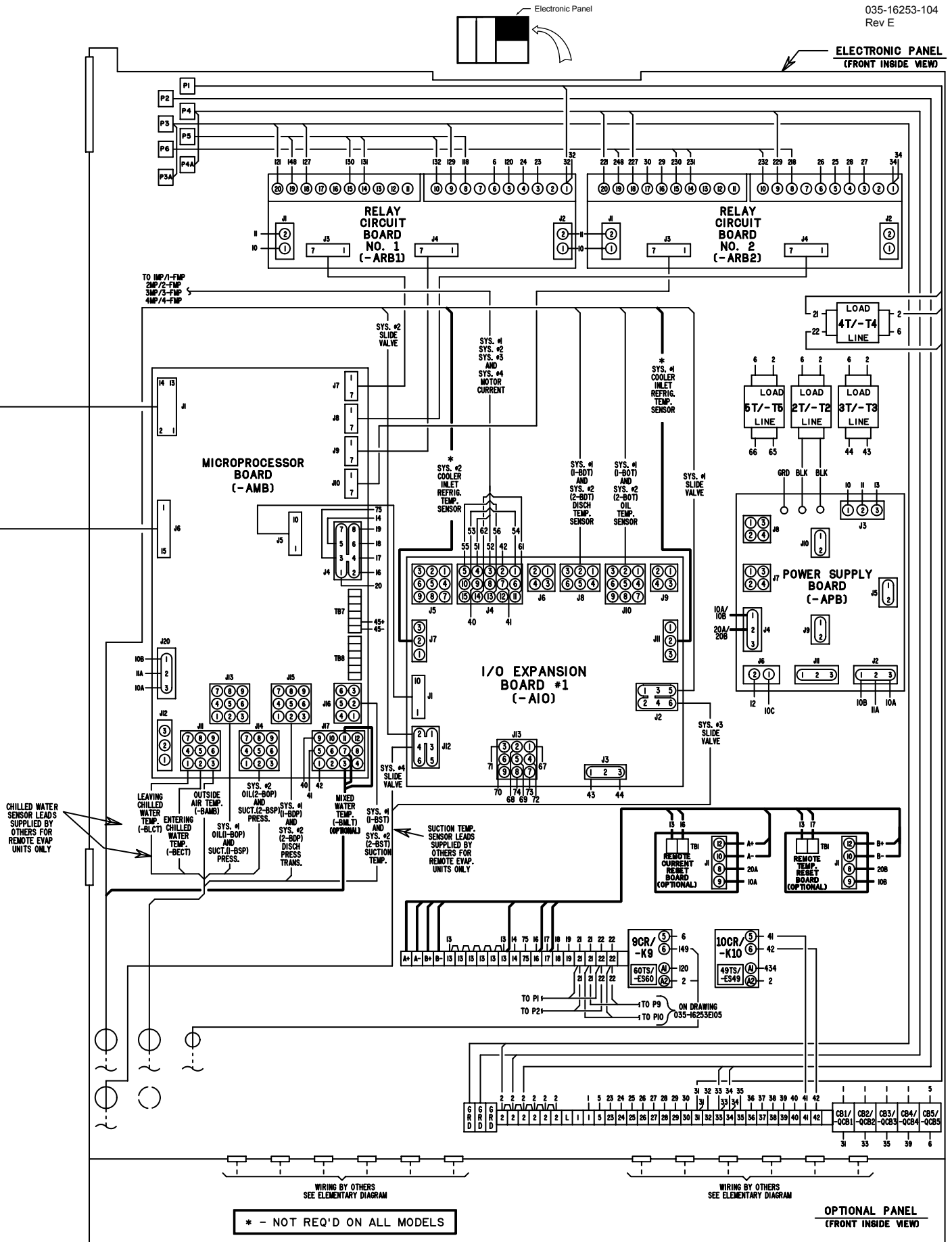



# CONNECTION WIRING DIAGRAM

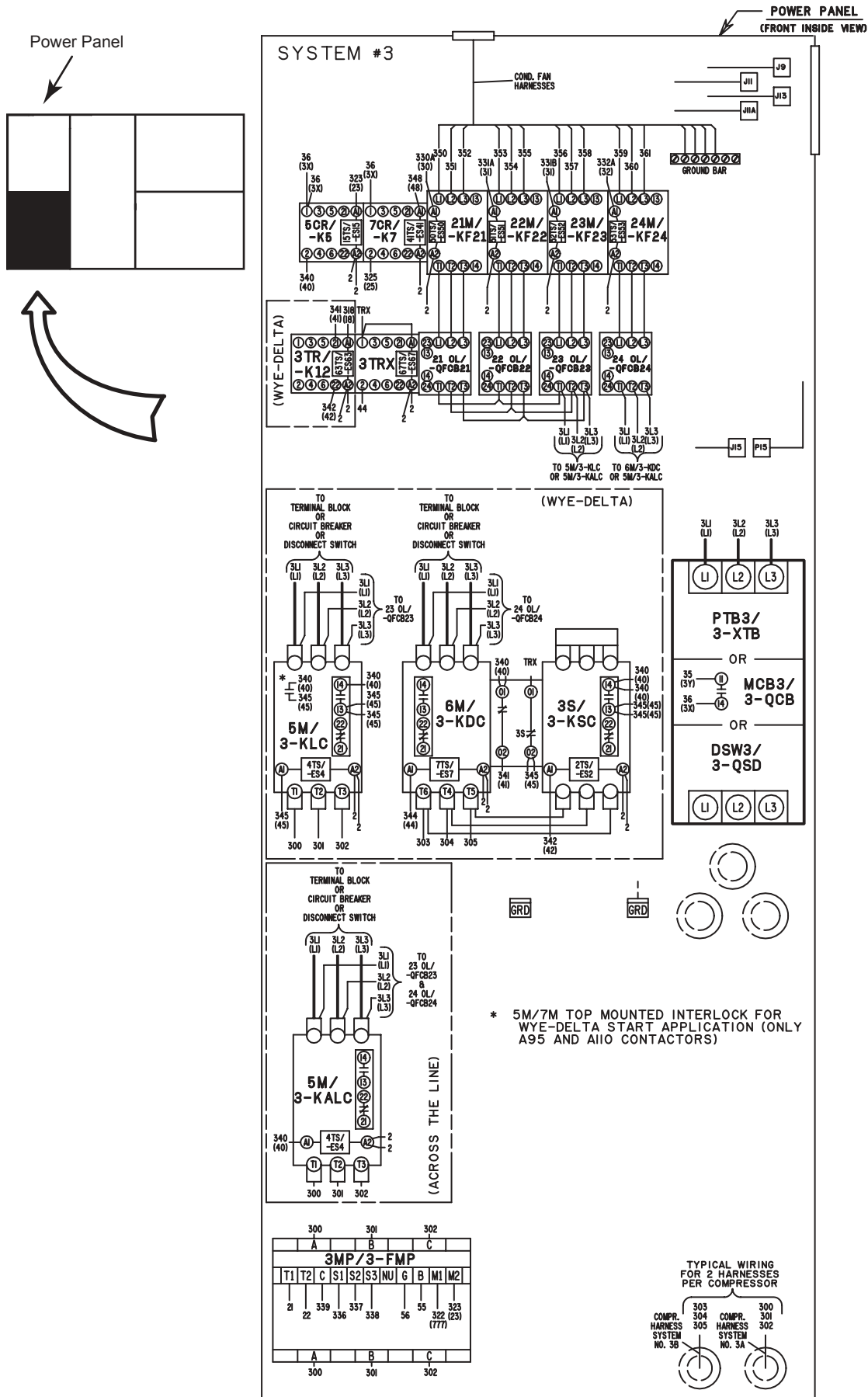

035-16253-105  
Rev D



# CONNECTION WIRING DIAGRAM

035-16253-105  
Rev D

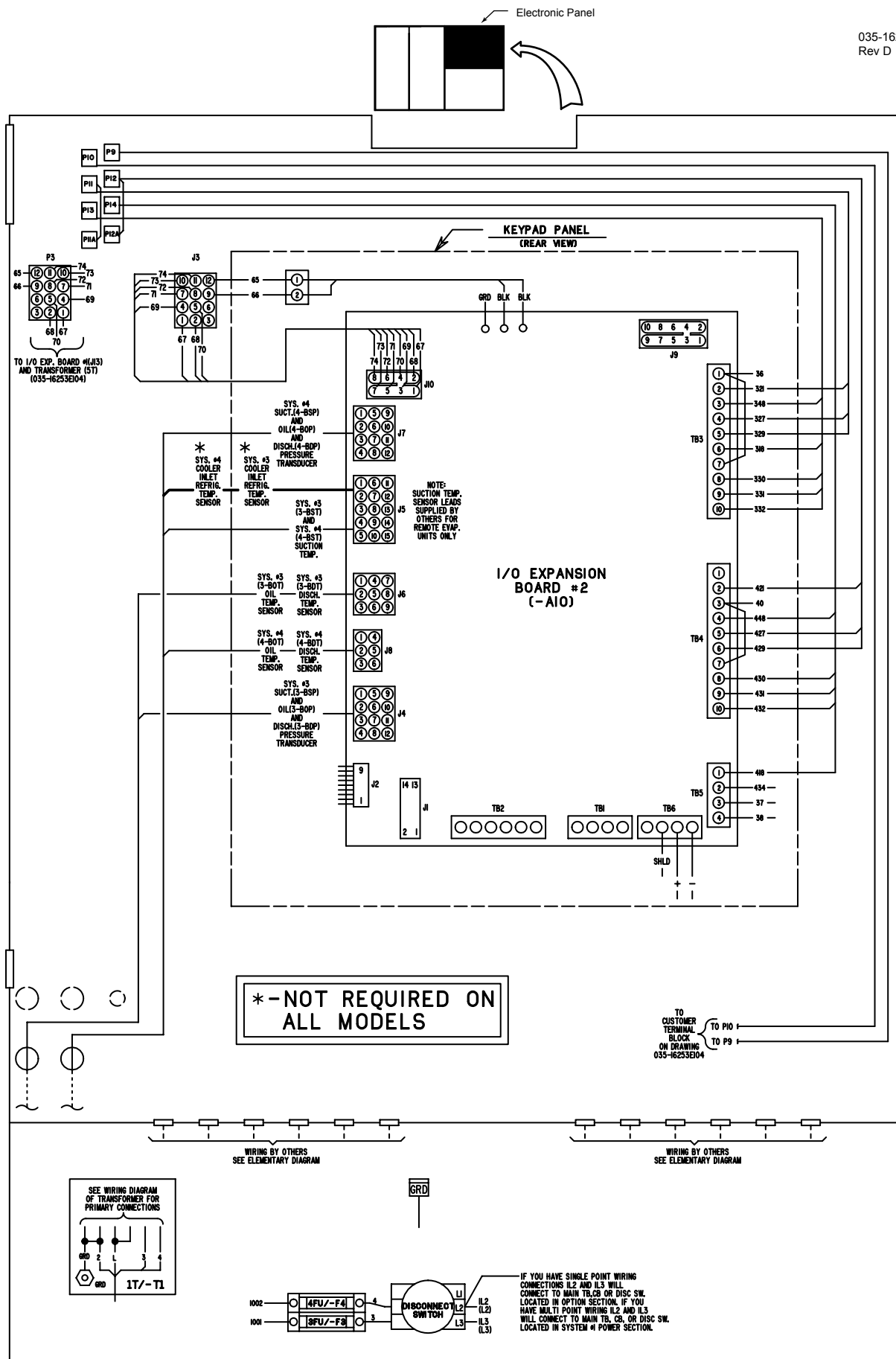
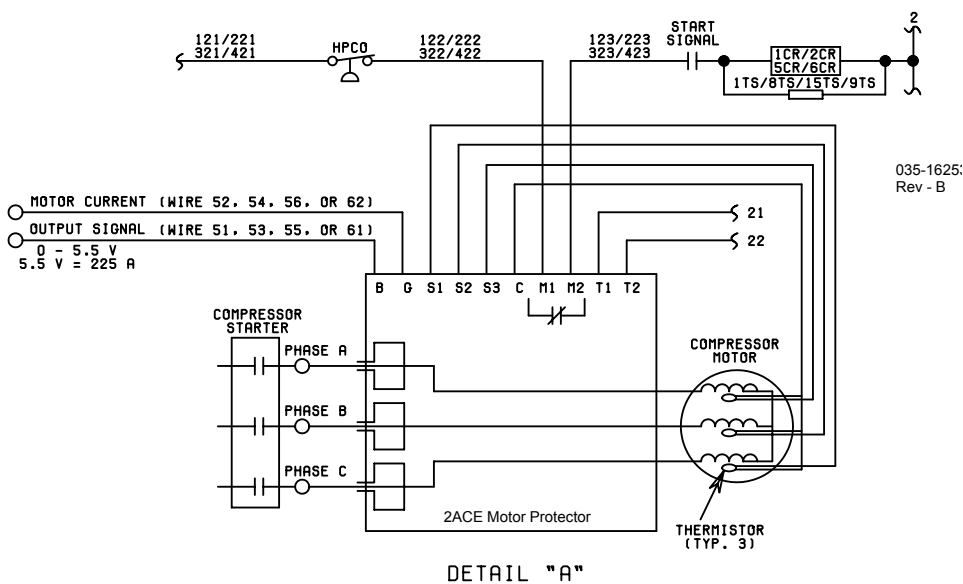

FIG. 46 – CONNECTION DIAGRAM

LD10053

# ELEMENTARY DIAGRAM DXST STARTER CONTROL CIRCUIT



035-16253-102  
Rev D

035-1625:  
Rev - B

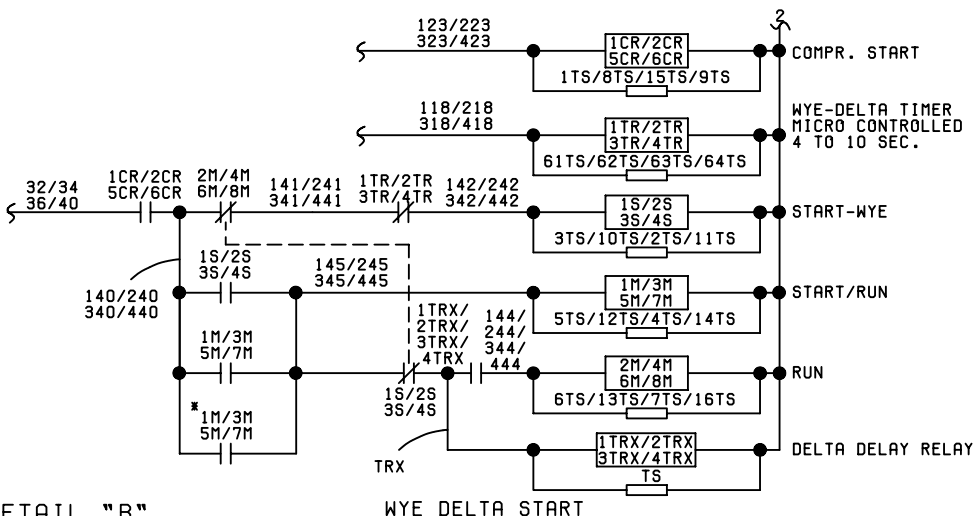

\* INTERLOCK ON TOP MOUNTED RELAY, WYE-DELTA  
(ONLY ON A95 & A110 CONTRACTORS)

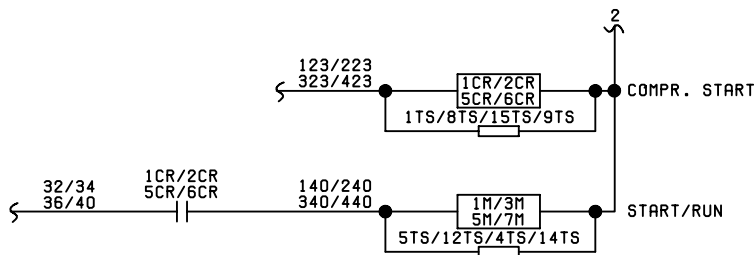
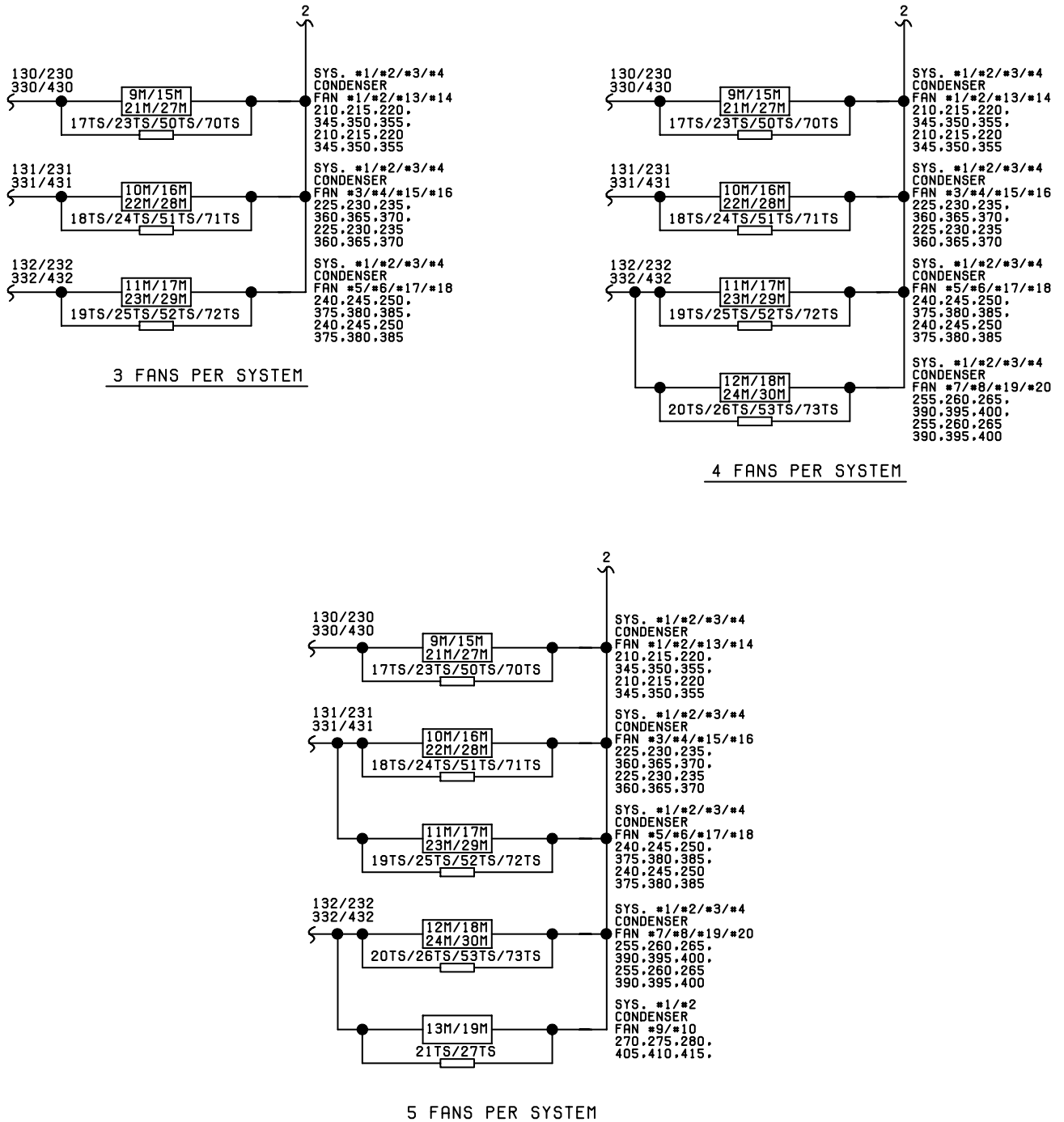

**FIG. 47 – CONNECTION DIAGRAM SYSTEM WIRING**

# ELEMENTARY DIAGRAM DXST FAN CONTROL CIRCUIT

035-16253-102  
Rev D

035-16253-102  
Rev - B



DETAIL "C"

FIG. 48 – CONNECTION DIAGRAM SYSTEM WIRING

# CONNECTION DIAGRAM SYSTEM WIRING STANDARD AND REMOTE EVAP UNITS

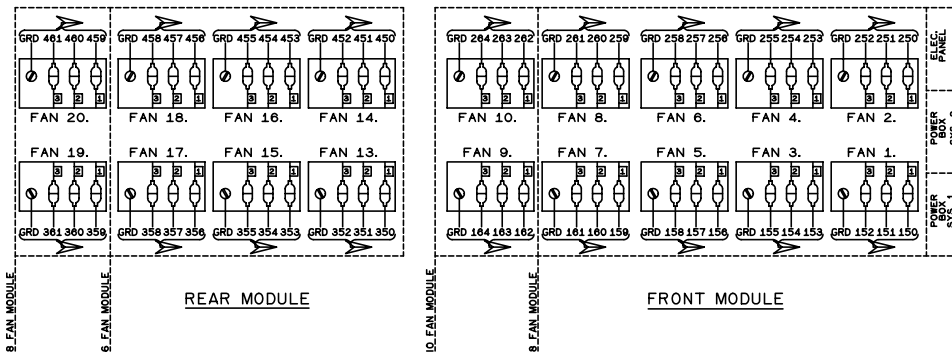

CONNECTION DIAGRAMS SYSTEM WIRING  
YCAS 0360 - 0440  
STANDARD & REMOTE EVAP.UNITS

035-19206-106  
R035-19206-106  
Rev a

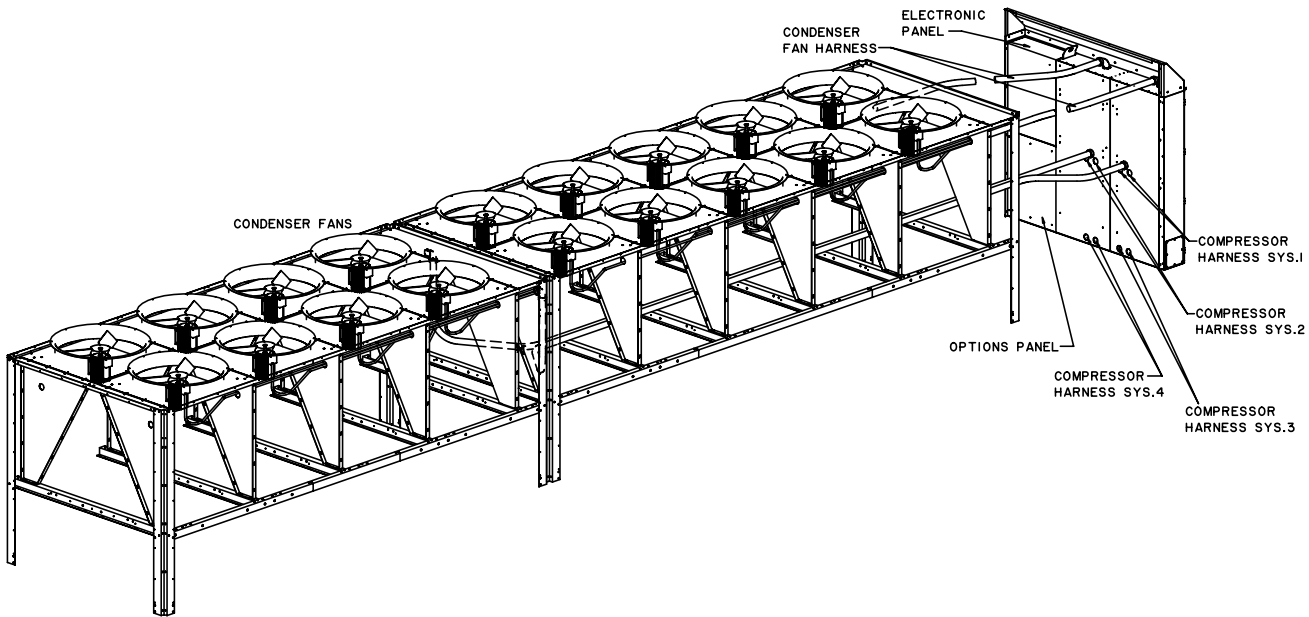

### LEGEND

- 1 HPCO      SYS. NO.1 HIGH PRESS. CUTOUT
- 2 HPCO      SYS. NO.2 HIGH PRESS. CUTOUT
- 3 HPCO      SYS. NO.3 HIGH PRESS. CUTOUT
- 4 HPCO      SYS. NO.4 HIGH PRESS. CUTOUT
- 1 HTR      SYS.NO.1 COMPR. CRANKCASE HEATER
- 2 HTR      SYS.NO.2 COMPR. CRANKCASE HEATER
- 3 HTR      SYS.NO.3 COMPR. CRANKCASE HEATER
- 4 HTR      SYS.NO.4 COMPR. CRANKCASE HEATER
- 5 HTR      COOLER HEATER
- 1 LLSV      SYS.NO.1 LIQUID LINE SOLENIOD VALVE (UNIT IDENT)
- 2 LLSV      SYS.NO.2 LIQUID LINE SOLENIOD VALVE (UNIT IDENT)
- 3 LLSV      SYS.NO.3 LIQUID LINE SOLENIOD VALVE (UNIT IDENT)
- 4 LLSV      SYS.NO.4 LIQUID LINE SOLENIOD VALVE (UNIT IDENT)
- 1 ESV      ECONOMIZER SOLENIOD VAVLE (UNIT IDENT)
- 2 ESV      ECONOMIZER SOLENIOD VAVLE (UNIT IDENT)
- 3 ESV      ECONOMIZER SOLENIOD VAVLE (UNIT IDENT)
- 4 ESV      ECONOMIZER SOLENIOD VAVLE (UNIT IDENT)
- TXV 1      SYS.NO.1 THERMAL EXPANSION VALVE (UNIT IDENT)
- TXV 2      SYS.NO.2 THERMAL EXPANSION VALVE (UNIT IDENT)
- TXV 3      SYS.NO.3 THERMAL EXPANSION VALVE (UNIT IDENT)
- TXV 4      SYS.NO.4 THERMAL EXPANSION VALVE (UNIT IDENT)

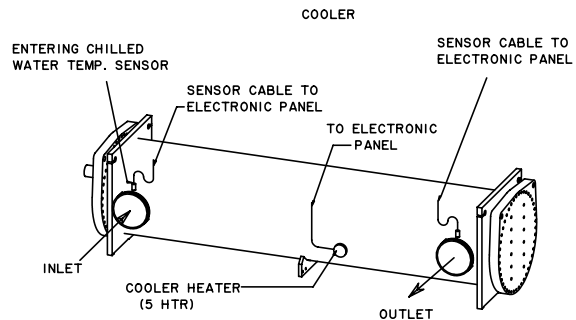

FIG. 49 – CONNECTION DIAGRAM SYSTEM WIRING

LD09383

# CONNECTION DIAGRAM SYSTEM WIRING STANDARD AND REMOTE EVAP UNITS

035-19206-106  
Rev a  
035-19206-106  
Rev -

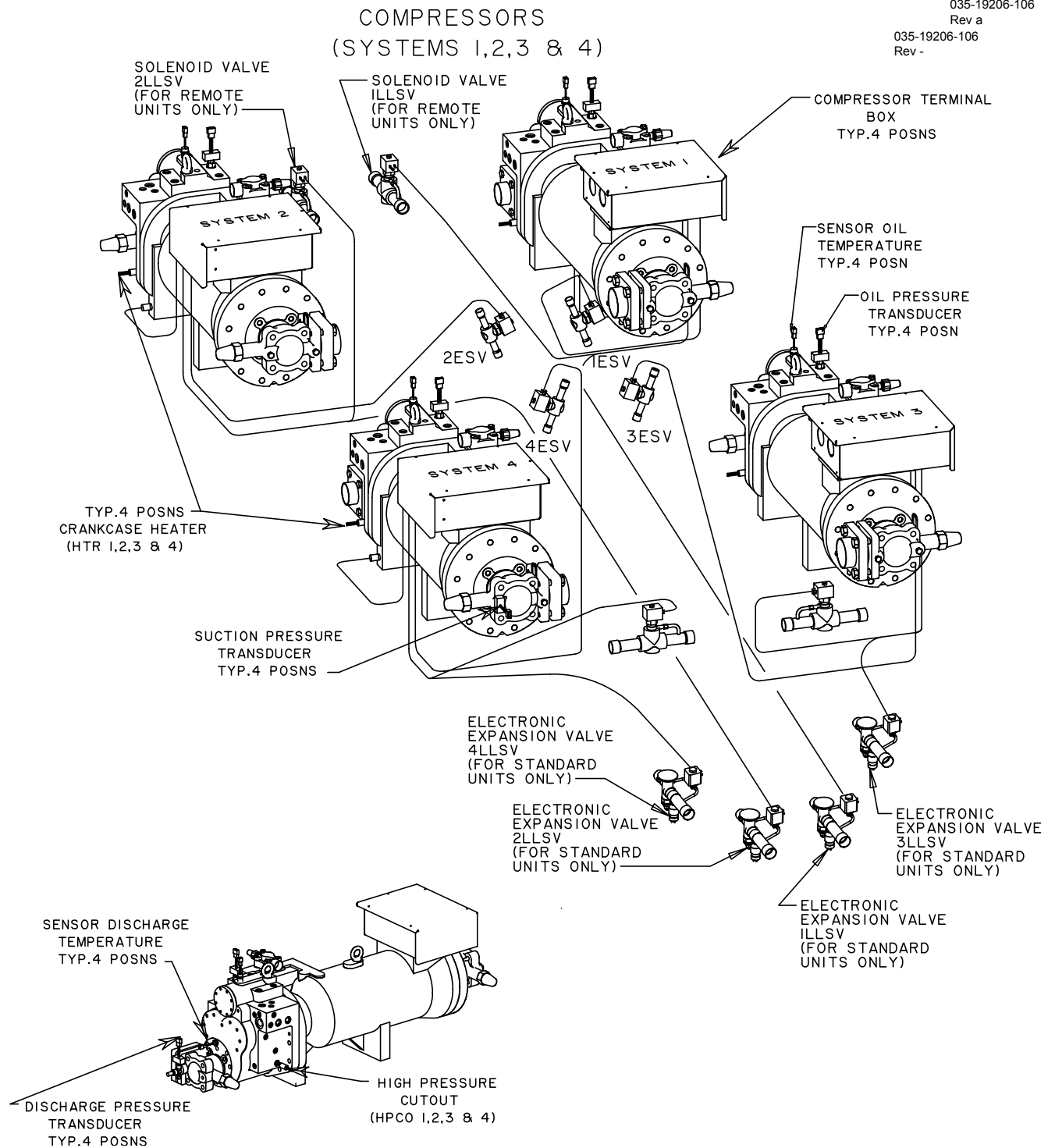

FIG. 49 – CONNECTION DIAGRAM SYSTEM WIRING (CONT'D)

# COMPRESSOR TERMINAL BOX SYSTEM 1 THROUGH 4

035-19206-106  
Rev a

**SYSTEM 1**  
COMPRESSOR TERMINAL BOX  
ACROSS THE LINE  
USE (XXX) FOR WYE-DELTA-START

SEE SAFTY RELIEF DEVICE KIT FOR  
WIRING OF RELIEF DEVICES IN CMTB  
  
JUMPERS ONLY REQUIRED  
ON ACROSS THE LINE UNITS

**SYSTEM 2**  
COMPRESSOR TERMINAL BOX  
ACROSS THE LINE  
USE (XXX) FOR WYE-DELTA-START

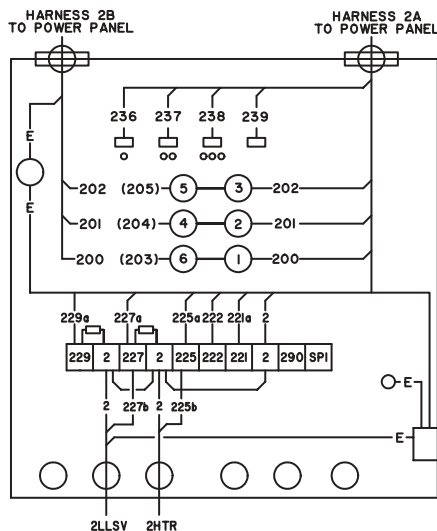
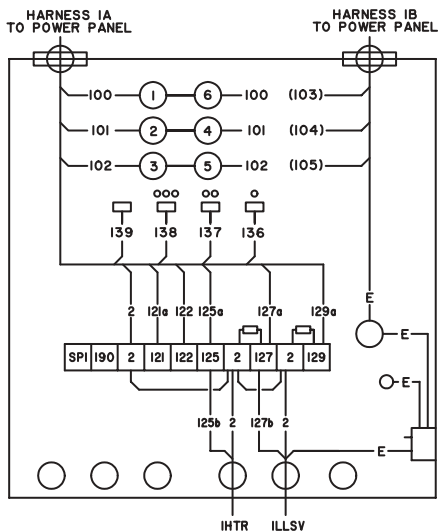

**SYSTEM 3**  
COMPRESSOR TERMINAL BOX  
ACROSS THE LINE  
USE (XXX) FOR WYE-DELTA-START

**SYSTEM 4**  
COMPRESSOR TERMINAL BOX  
ACROSS THE LINE  
USE (XXX) FOR WYE-DELTA-START

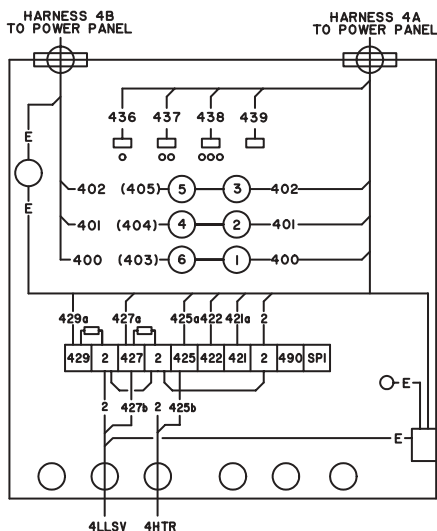
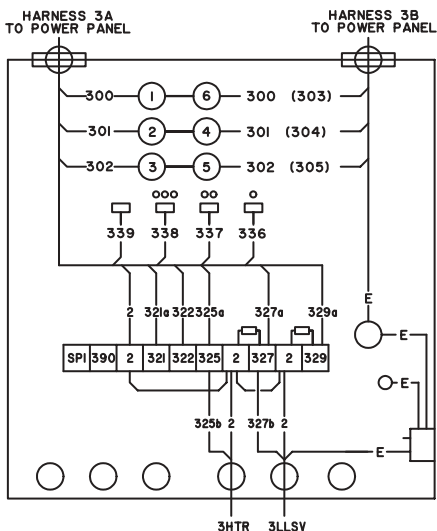

LD10054

This page intentionally left blank.

### DIMENSIONS – YCAS0685 (SI)

All dimensions are in mm unless otherwise noted.

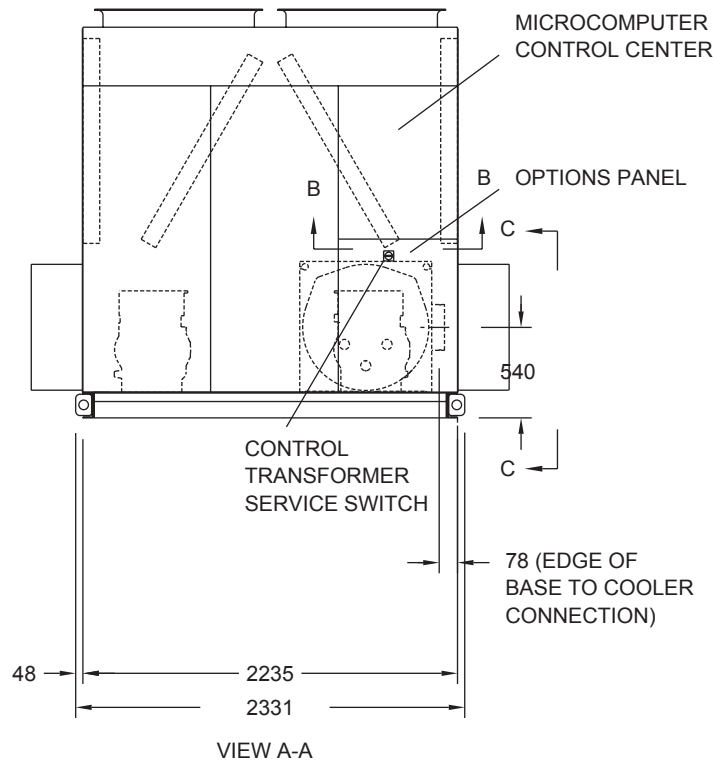
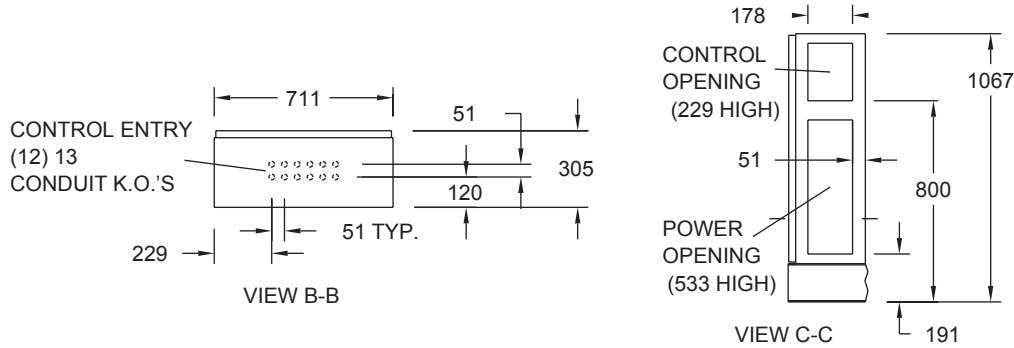

LD06107

**NOTES:**

1. Placement on a level surface free of obstructions (including snow, for winter operation) or air recirculation ensures rated performance, reliable operation and ease of maintenance. Site restrictions may compromise minimum clearances indicated below, resulting in unpredictable air flow patterns and possible diminished performance. YORK's unit controls will optimize operation without nuisance high pressure safety cutout; however, the system designer must consider potential performance degradation. Access to the unit control center assumes the unit is no higher than on spring isolators. Recommended minimum clearances: Side to wall - 2m; rear to wall - 2m; control panel end to wall - 1.2m; top - no obstructions allowed; distance between adjacent units - 3m. No more than one adjacent wall may be higher than the unit.

FIG. 50 – MODEL YCAS0685 (SI)

### DIMENSIONS – YCAS0685 (SI)

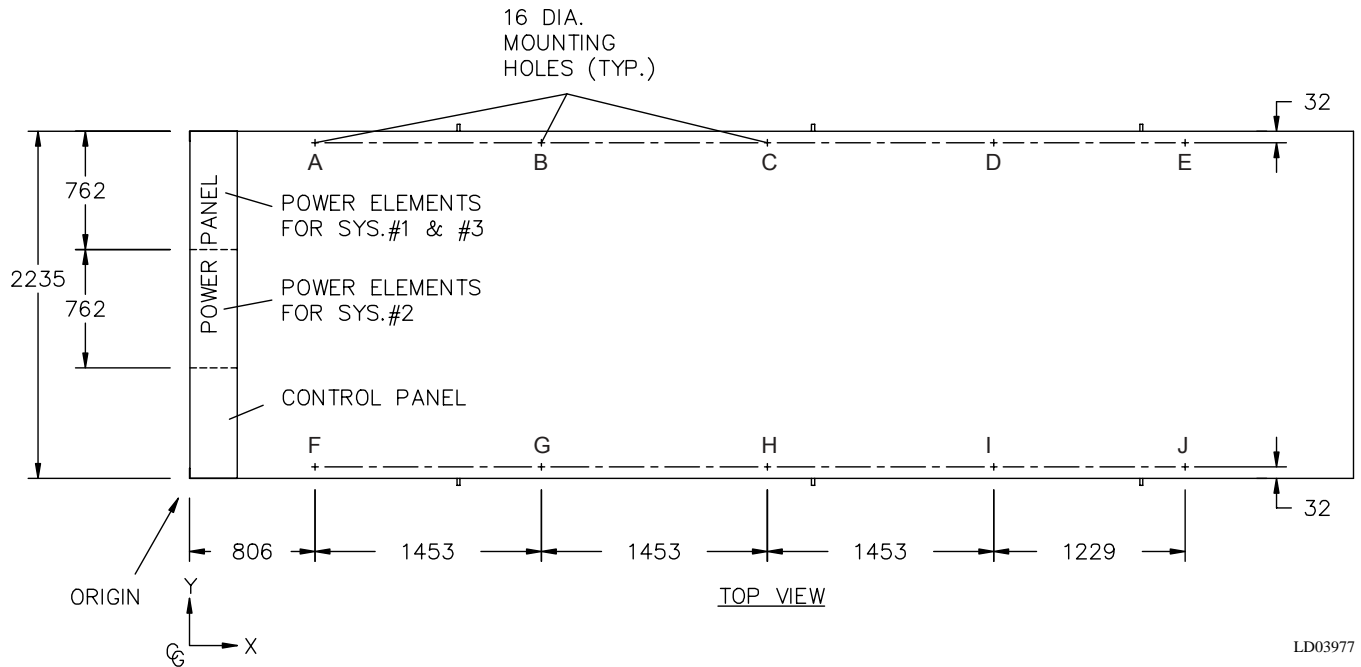

LD03977

CENTER OF GRAVITY (Alum.)			
YCAS	X	Y	Z
0685	3689	999	901

CENTER OF GRAVITY (Copper)			
YCAS	X	Y	Z
0685	3711	1008	954

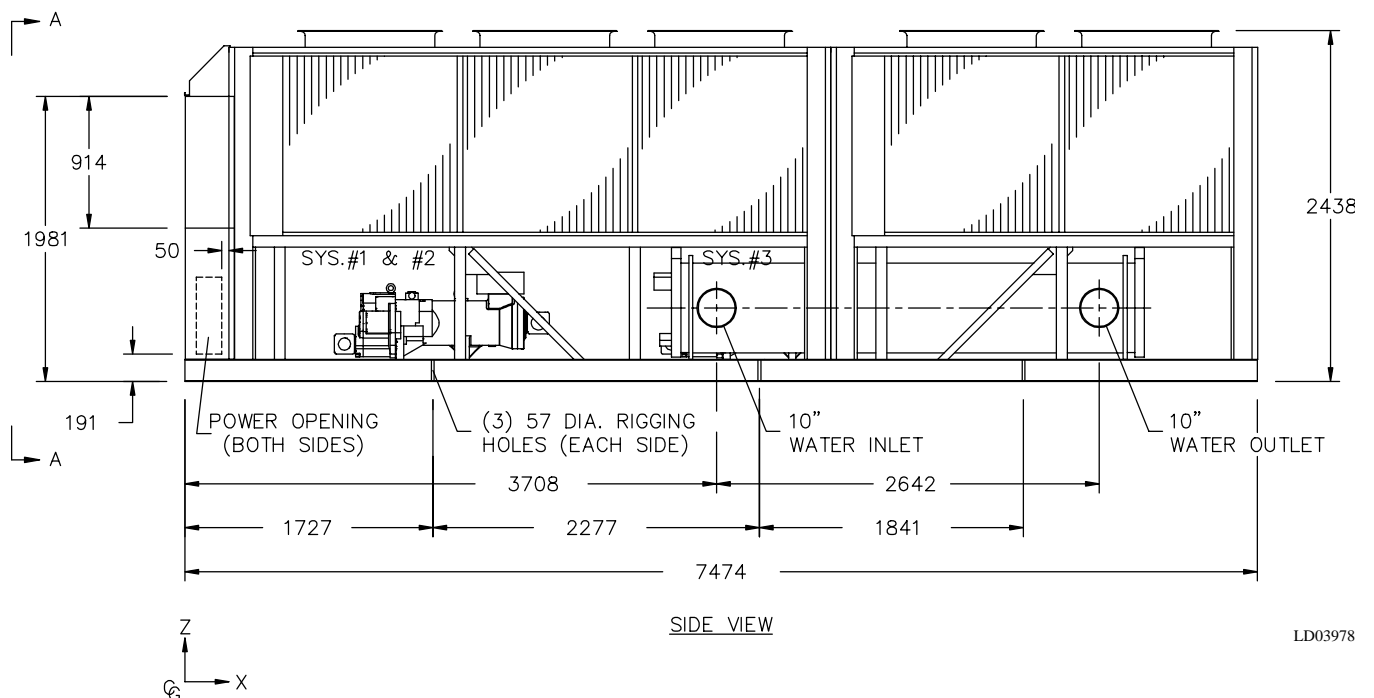

LD03978

**DIMENSIONS – YCAS0775 - YCAS0905 (SI)**

*All dimensions are in mm unless otherwise noted.*

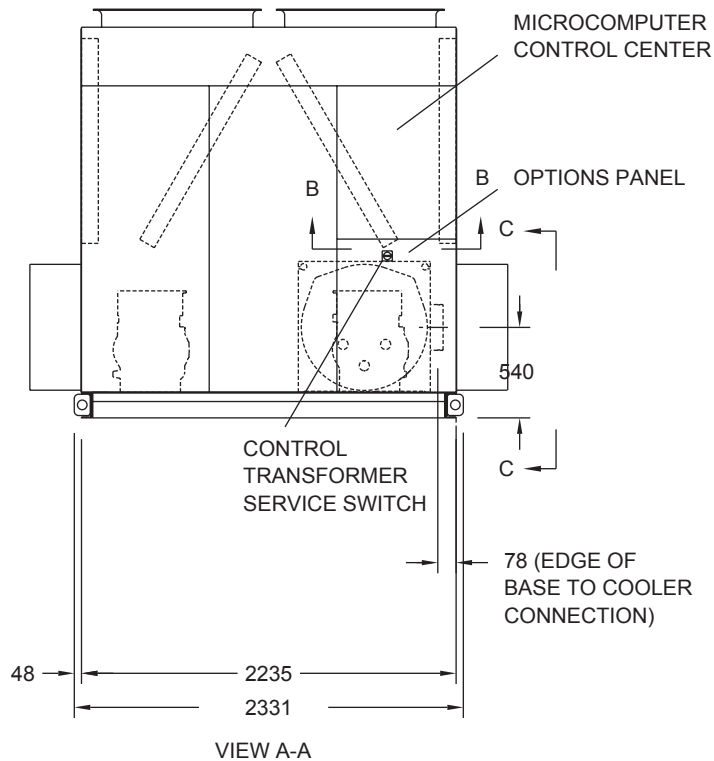
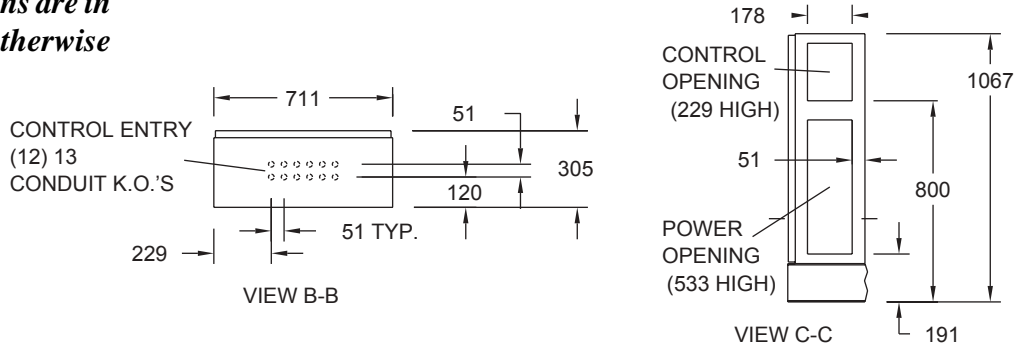

LD06107

**NOTES:**

1. Placement on a level surface free of obstructions (including snow, for winter operation) or air recirculation ensures rated performance, reliable operation and ease of maintenance. Site restrictions may compromise minimum clearances indicated below, resulting in unpredictable air flow patterns and possible diminished performance. YORK's unit controls will optimize operation without nuisance high pressure safety cutout; however, the system designer must consider potential performance degradation. Access to the unit control center assumes the unit is no higher than on spring isolators. Recommended minimum clearances: Side to wall - 2m; rear to wall - 2m; control panel end to wall - 1.2m; top - no obstructions allowed; distance between adjacent units - 3m. No more than one adjacent wall may be higher than the unit.

**FIG. 51 – MODEL YCAS0775 - 0905 DIMENSIONS (SI)**

## DIMENSIONS – YCAS0775 - YCAS0905 (SI)

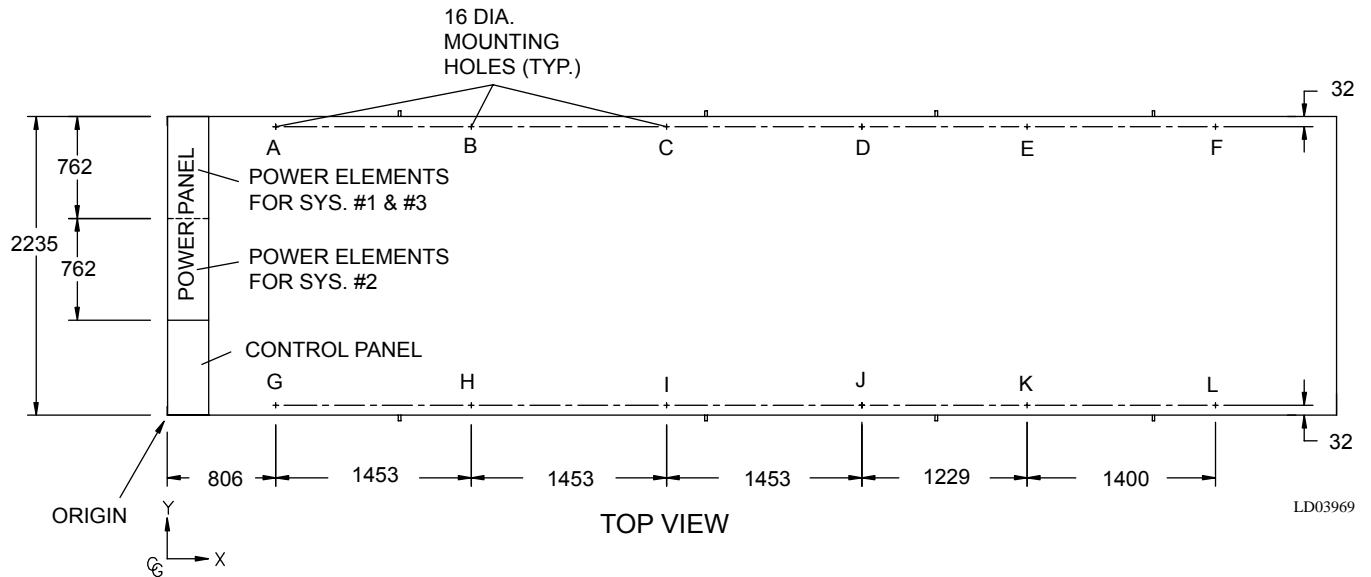

**CENTER OF GRAVITY (Alum.)**

YCAS	X	Y	Z
<b>0775</b>	4221	1024	886
<b>0835</b>	4215	1026	886
<b>0905</b>	4209	1027	886

**CENTER OF GRAVITY (Copper)**

YCAS	X	Y	Z
<b>0775</b>	4246	1031	947
<b>0835</b>	4240	1034	946
<b>0905</b>	4234	1034	943

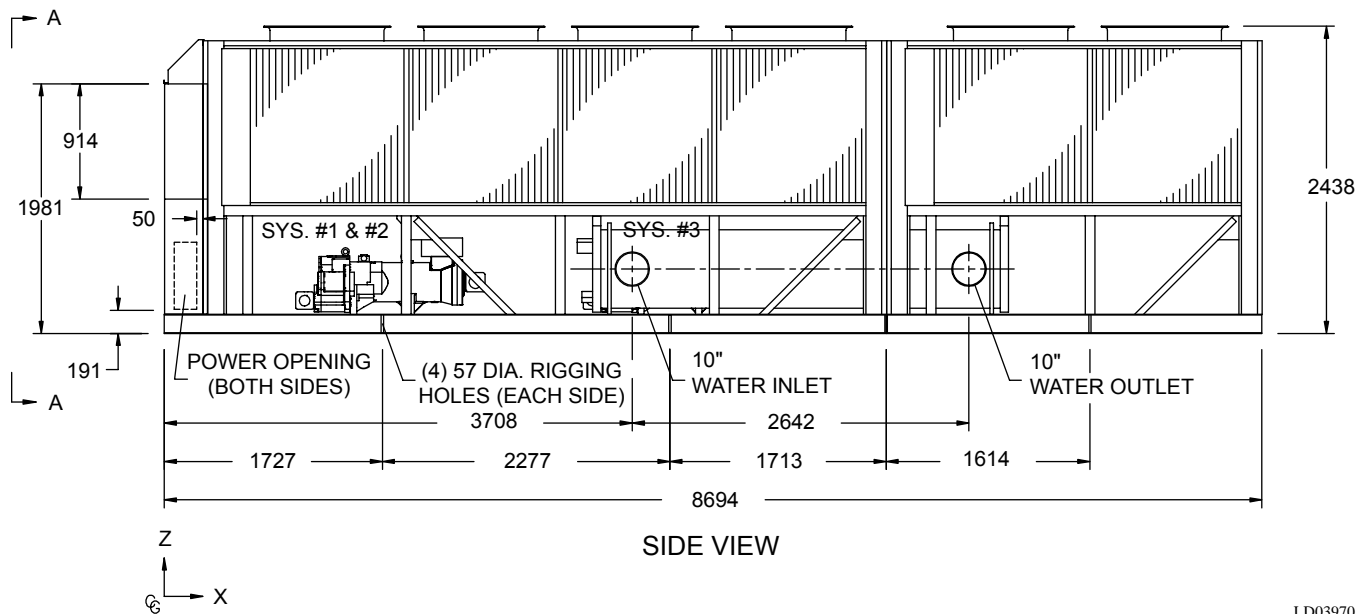

### DIMENSIONS – YCAS0965 (SI)

*All dimensions are in mm unless otherwise noted.*

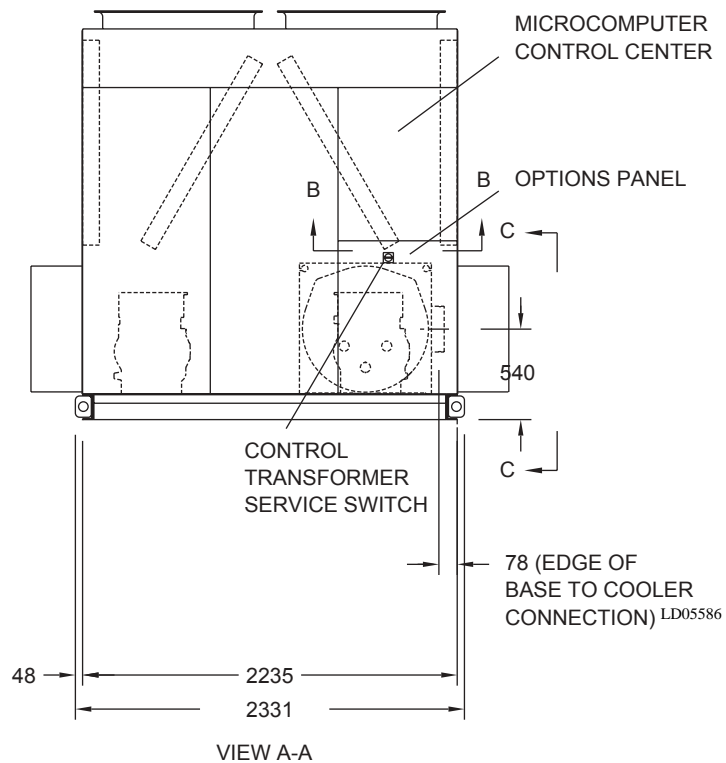
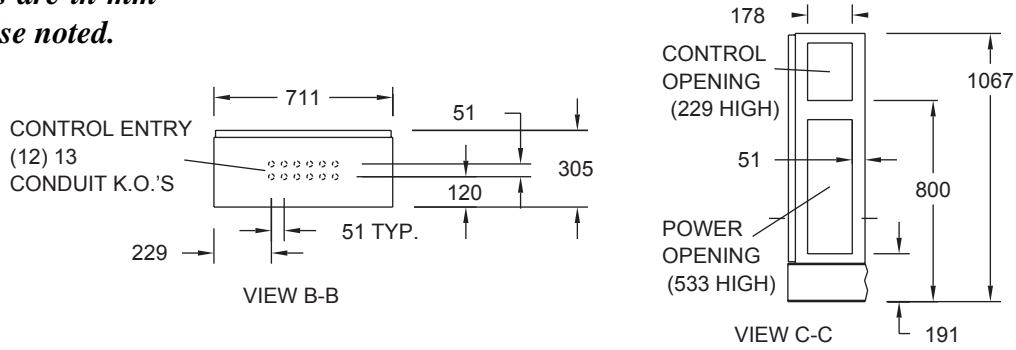

**NOTES:**

1. Placement on a level surface free of obstructions (including snow, for winter operation) or air recirculation ensures rated performance, reliable operation and ease of maintenance. Site restrictions may compromise minimum clearances indicated below, resulting in unpredictable air flow patterns and possible diminished performance. YORK's unit controls will optimize operation without nuisance high pressure safety cutout; however, the system designer must consider potential performance degradation. Access to the unit control center assumes the unit is no higher than on spring isolators. Recommended minimum clearances: Side to wall - 2m; rear to wall - 2m; control panel end to wall - 1.2m; top - no obstructions allowed; distance between adjacent units - 3m. No more than one adjacent wall may be higher than the unit.

LD06107

**FIG. 52 – MODEL YCAS0965 DIMENSIONS (SI)**

## DIMENSIONS – YCAS0965 (SI)

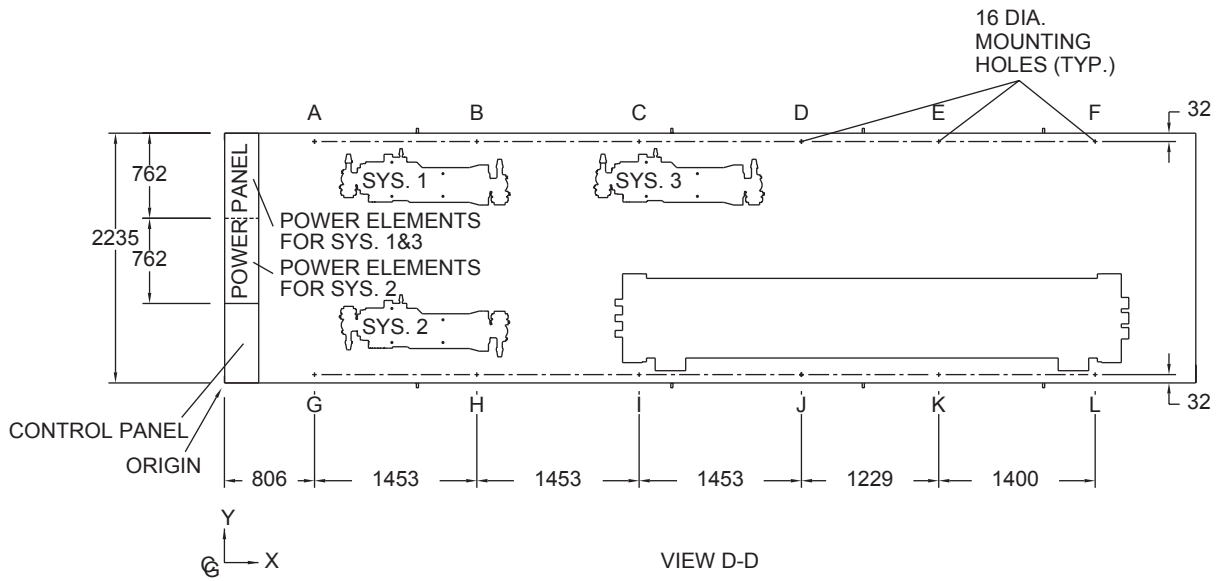

LD05587

**CENTER OF GRAVITY (Alum.)**

YCAS	X	Y	Z
0965	4854	1042	996

**CENTER OF GRAVITY (Copper)**

YCAS	X	Y	Z
0965	4938	1049	1056

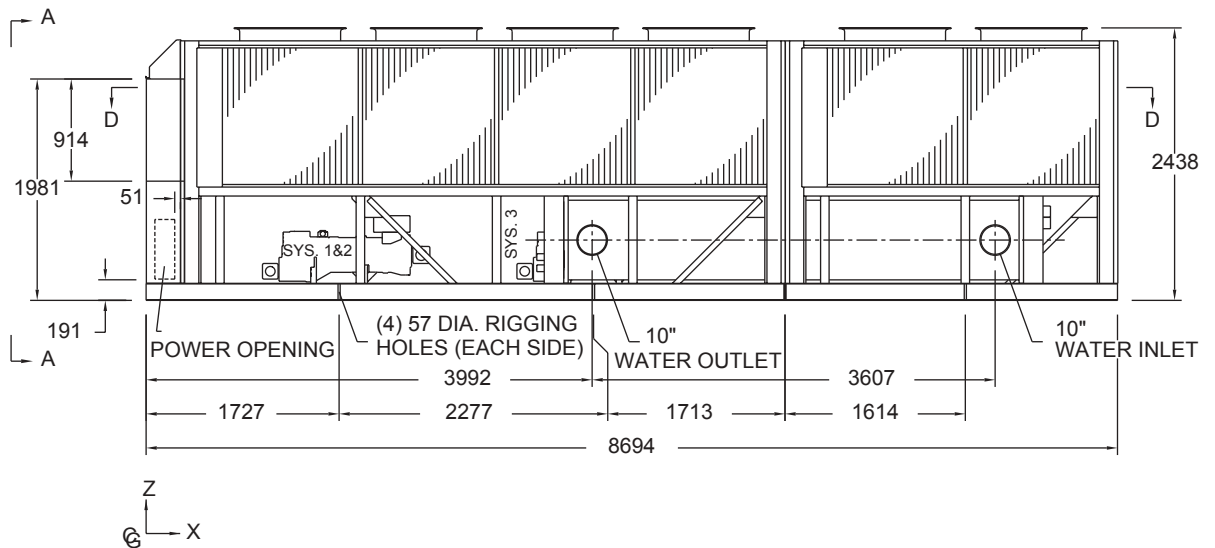

LD05588

**DIMENSIONS – YCAS1065 - YCAS1215 (SI)**

*All dimensions are in mm unless otherwise noted.*

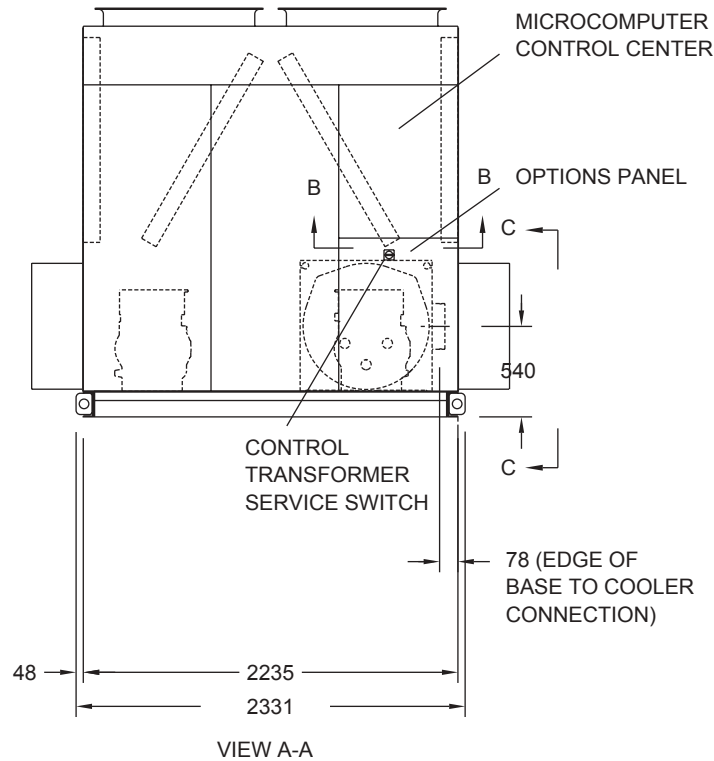
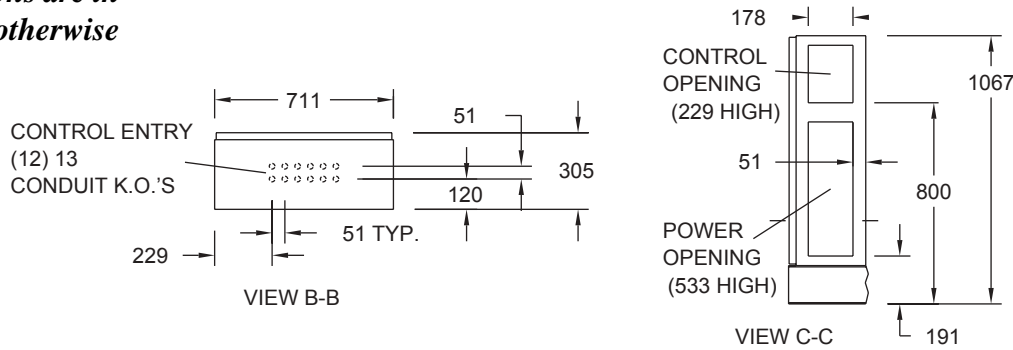

**NOTES:**

LD06107

1. Placement on a level surface free of obstructions (including snow, for winter operation) or air recirculation ensures rated performance, reliable operation and ease of maintenance. Site restrictions may compromise minimum clearances indicated below, resulting in unpredictable air flow patterns and possible diminished performance. YORK's unit controls will optimize operation without nuisance high pressure safety cutout; however, the system designer must consider potential performance degradation. Access to the unit control center assumes the unit is no higher than on spring isolators. Recommended minimum clearances: Side to wall - 2m; rear to wall - 2m; control panel end to wall - 1.2m; top - no obstructions allowed; distance between adjacent units - 3m. No more than one adjacent wall may be higher than the unit.

**FIG. 53 – MODEL YCAS1065 - YCAS1215 (SI)**

## DIMENSIONS – YCAS1065 - YCAS1215 (SI)

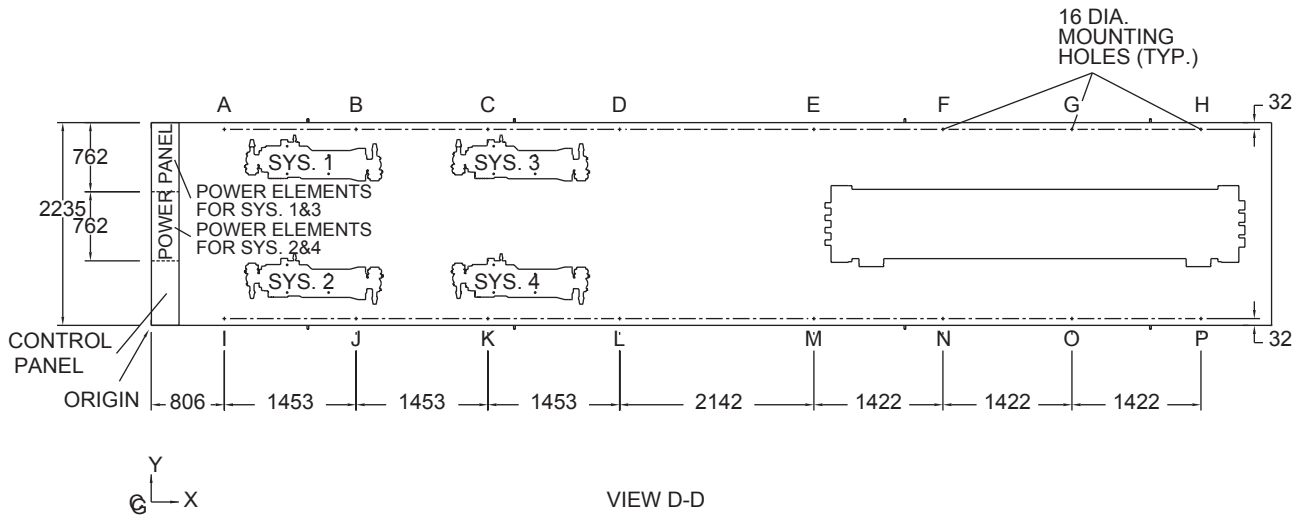

**CENTER OF GRAVITY (Alum.)**

YCAS	X	Y	Z
1065	5654	1119	896
1135	5637	1128	957
1215	5632	1128	954

**CENTER OF GRAVITY (Copper)**

YCAS	X	Y	Z
1065	5646	1119	956
1135	5631	1127	1012
1215	5627	1127	1010

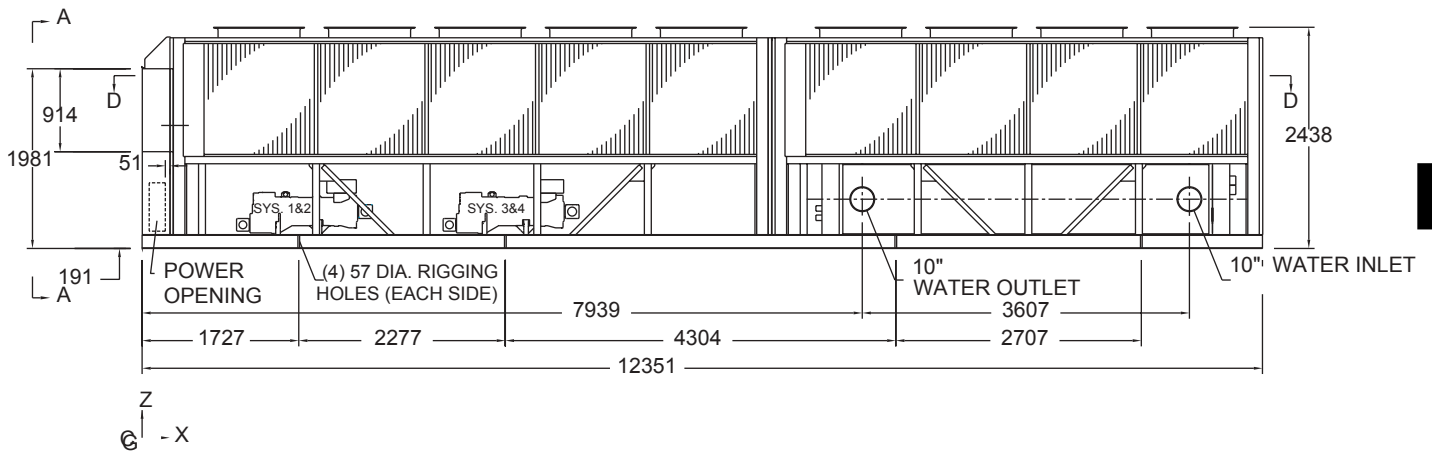

LD06136

### TECHNICAL DATA CLEARANCES

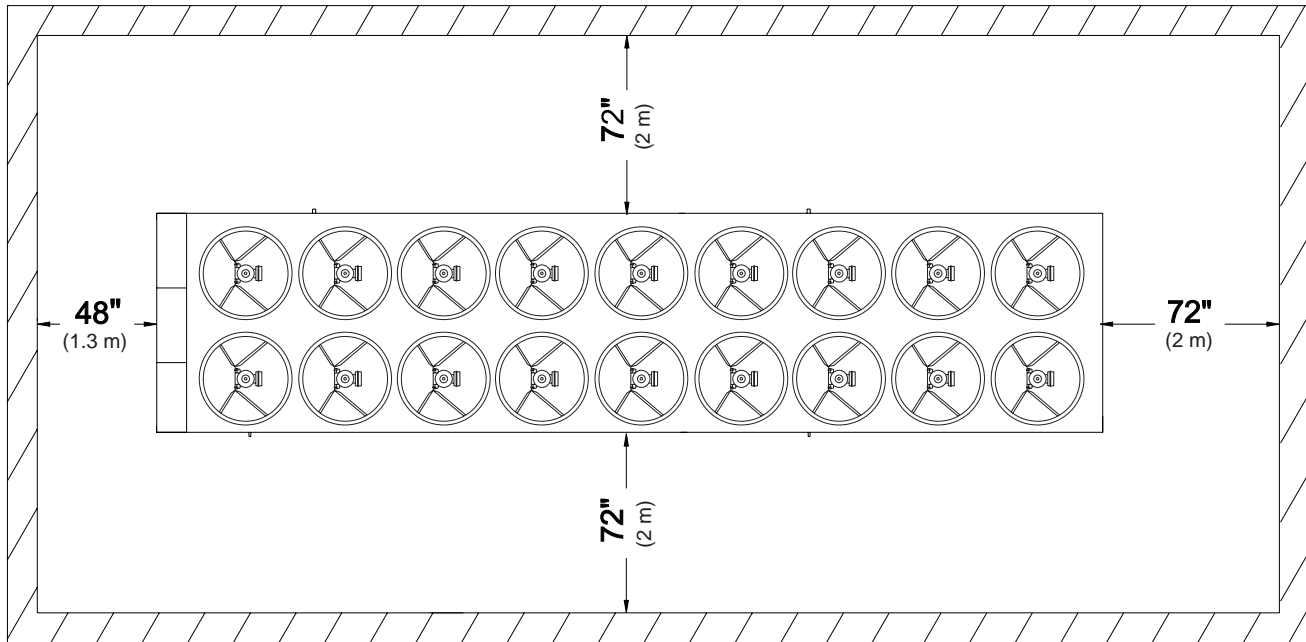

LD09409

**NOTES:**

1. No obstructions allowed above the unit.
2. Only one adjacent wall may be higher than the unit.
3. Adjacent units should be 10 feet (3 meters) apart.

**FIG. 54 – CLEARANCES**

# WEIGHT DISTRIBUTION AND ISOLATOR MOUNTING POSITIONS

## Aluminium Fin and Black Fin Coils

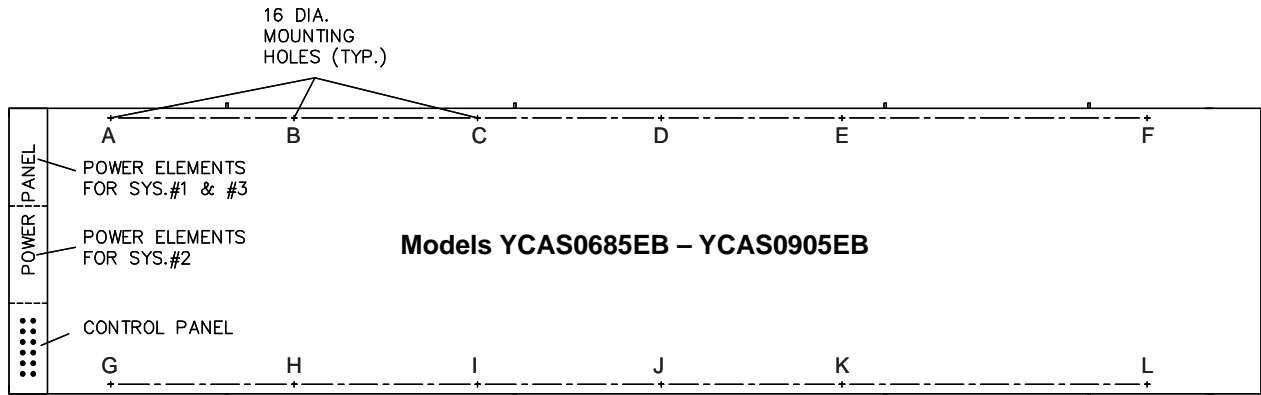

LD04126

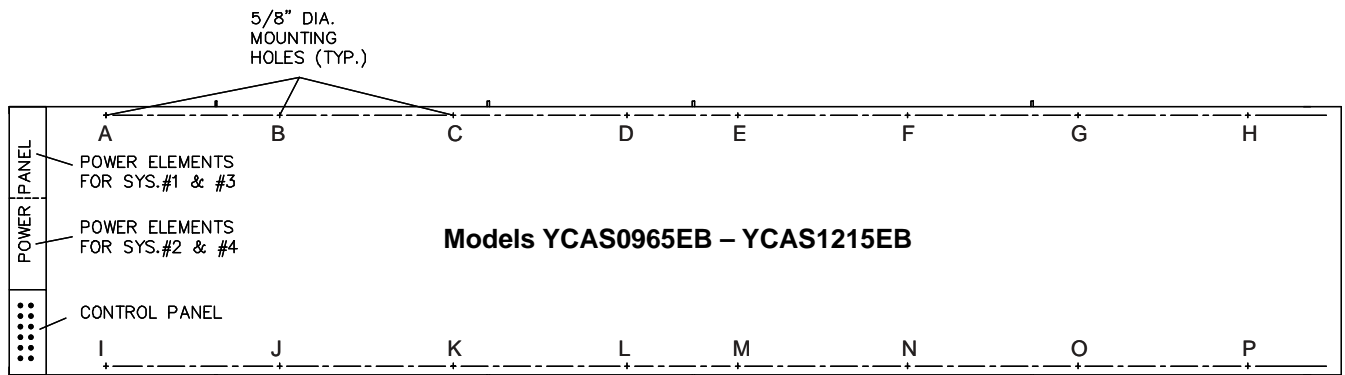

LD04127

### ALUMINUM FINS WEIGHT DISTRIBUTION (kgs.) BY MODEL

MODEL	A	B	C	D	E	F	G	H	I	J	K	L	M	N	O	P	Total
YCAS0685	878	1,013	957	492	716	878	1,248	1,043	733	1,124	---	---	---	---	---	---	9,081
YCAS0775	885	778	1,024	617	536	657	885	778	1,168	718	699	1,071	---	---	---	---	9,817
YCAS0835	898	797	1,028	623	542	662	892	787	1,173	725	705	1,076	---	---	---	---	9,906
YCAS0905	902	802	1,046	630	544	664	902	802	1,178	729	708	1,078	---	---	---	---	9,986
YCAS0965	865	767	1,012	605	578	551	357	276	840	730	1,124	711	819	869	357	276	10,737
YCAS1065	877	809	824	570	1,080	624	559	1,155	855	772	694	640	1,148	554	559	1,155	12,877
YCAS1135	889	828	826	572	1,080	625	561	1,156	866	789	695	642	1,150	555	561	1,156	12,950
YCAS1215	888	828	845	579	1,081	625	560	1,157	865	788	712	650	1,150	555	560	1,157	13,000

# WEIGHT DISTRIBUTION AND ISOLATOR MOUNTING POSITIONS

## Aluminium Fin and Black Fin Coils

### ALUMINUM FINNS, 1" ISOLATOR SELECTIONS – VMC TYPE CP-2-XX – (See Table below)

MODEL	A	B	C	D	E	F	G	H	I	J	K	L	M	N	O	P
YCAS0685	2-31	2-32	2-31	2-26	2-28	2-31	2-35	2-32	2-28	2-32	---	---	---	---	---	---
YCAS0775	2-31	2-28	2-32	2-27	2-26	2-27	2-31	2-28	2-32	2-28	2-28	2-32	---	---	---	---
YCAS0835	2-31	2-28	2-32	2-27	2-26	2-27	2-31	2-28	2-32	2-28	2-28	2-32	---	---	---	---
YCAS0905	2-31	2-28	2-32	2-27	2-26	2-27	2-31	2-28	2-32	2-28	2-28	2-32	---	---	---	---
YCAS0965	2-31	2-28	2-32	2-27	2-27	2-26	2-25	2-25	2-31	2-28	2-32	2-28	2-31	2-31	2-25	2-25
YCAS1065	2-31	2-28	2-31	2-27	2-32	2-27	2-27	2-32	2-31	2-28	2-28	2-27	2-32	2-27	2-27	2-32
YCAS1135	2-31	2-31	2-31	2-27	2-32	2-27	2-27	2-32	2-31	2-28	2-28	2-27	2-32	2-27	2-27	2-32
YCAS1215	2-31	2-31	2-31	2-27	2-32	2-27	2-27	2-32	2-31	2-28	2-28	2-27	2-32	2-27	2-27	2-32

ISOLATOR TYPE & SIZE	MAX LOAD		DEFL.		SPRING COLOR
	lbs.	kg	in.	mm	
CP-2-26	1,200	544.3	1.17	29.7	Purple
CP-2-27	1,500	680.4	1.06	26.9	Orange
CP-2-28	1,800	816.4	1.02	25.9	Green
CP-2-31	2,200	997.9	0.83	21.0	Gray
CP-2-32	2,600	1,179.3	0.74	18.7	White
CP-2-35	3,000	1,360.8	0.70	17.7	Gold

### ISOLATOR DETAILS

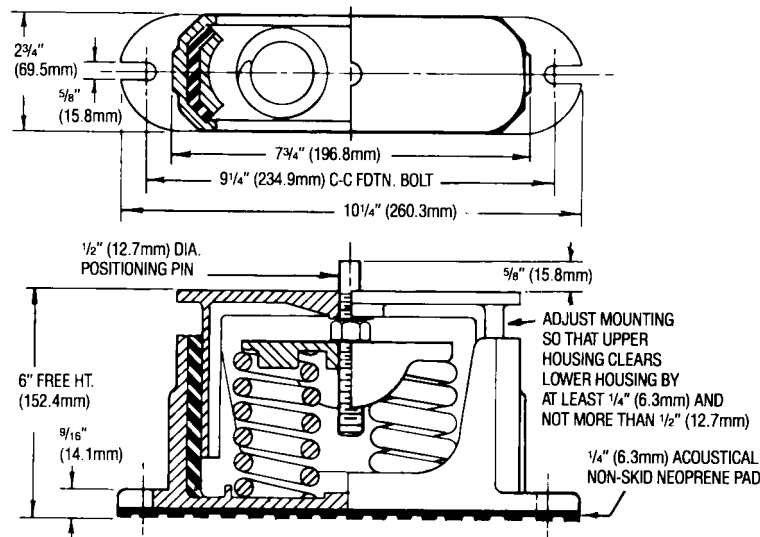

LD01089

FIG. 55 – CP-2-XX

## WEIGHT DISTRIBUTION AND ISOLATOR MOUNTING POSITIONS

### Aluminium Fin and Black Fin Coils

**ALUMINUM FINNS, SEISMIC ISOLATOR SELECTIONS – VMC MODEL # AWMR-X-XXX – (See Table below)**

MODEL	A	B	C	D	E	F	G	H	I	J	K	L	M	N	O	P
YCAS0685	1-553	2-530	2-530	1-530	1-551	1-553	2-532	2-530	1-551	2-531	---	---	---	---	---	---
YCAS0775	1-553	1-552	2-531	1-532	1-531	1-532	1-553	1-552	2-532	1-551	1-551	2-531	---	---	---	---
YCAS0835	1-553	1-552	2-531	1-532	1-531	1-532	1-553	1-552	2-532	1-551	1-551	2-531	---	---	---	---
YCAS0905	1-553	1-552	2-531	1-532	1-531	1-532	1-553	1-552	2-532	1-551	1-551	2-531	---	---	---	---
YCAS0965	1-553	1-552	2-530	2-521	2-520	1-531	1-530	1-520	1-552	1-551	2-531	2-53	2-53	2-53	1-530	1-520
YCAS1065	1-553	1-552	1-552	1-531	2-531	1-532	1-531	2-531	1-553	1-552	1-551	1-532	2-531	1-531	1-531	2-520
YCAS1135	1-553	1-552	1-552	1-531	2-531	1-532	1-531	2-531	1-553	1-552	1-551	1-532	2-531	1-531	1-531	2-520
YCAS1215	1-553	1-552	1-552	1-531	2-531	1-532	1-531	2-531	1-553	1-552	1-551	1-532	2-531	1-531	1-531	2-520

ISOLATOR TYPE & SIZE	MAX LOAD		DEFL.	
	lbs.	kg	in.	mm
AWMR-1-53	1000	453.6	2	51
AWMR-1-530	1150	521.6	2	51
AWMR-1-531	1276	578.8	2	51
AWMR-1-532	1500	680.4	2	51
AWMR-1-551	1676	760.2	2	51
AWMR-1-552	1900	861.8	2	51

ISOLATOR TYPE & SIZE	MAX LOAD		DEFL.	
	lbs.	kg	in.	mm
AWMR-1-553	2200	997.9	2	51
AWMR-2-520	1300	589.7	2	51
AWMR-2-521	1552	704.0	2	51
AWMR-2-53	2000	907.2	2	51
AWMR-1-530	2300	1043.3	2	51
AWMR-2-531	2552	1157.6	2	51
AWMR-2-532	3000	1360.8	2	51

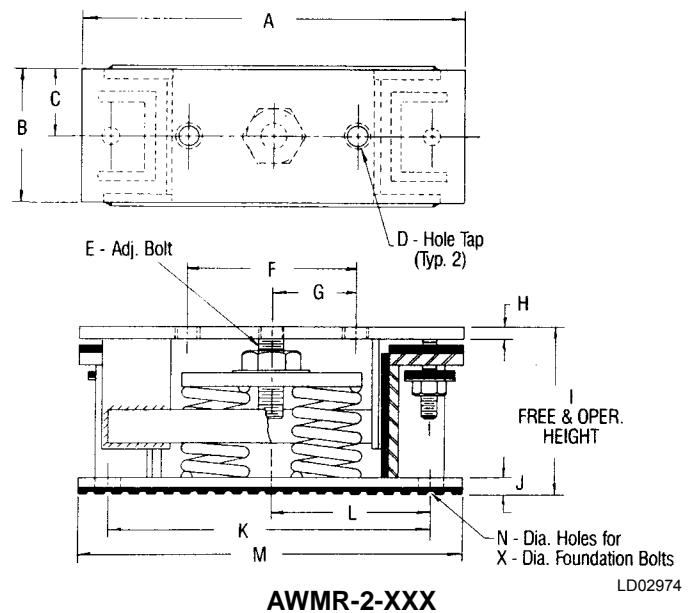
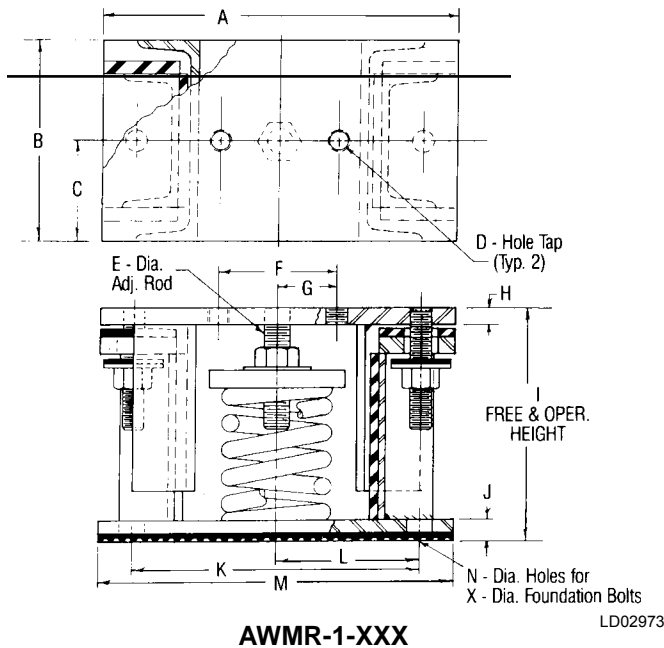

**DIMENSIONS - In.**

	A	B	C	D	E	F	G	H	I	J	K	L	M	N/X
<b>AWMR-1 50-553</b>	10-1/2	6	3	5/8 11NC	3/4	3-1/2	1-3/4	1/2	9	5/8	8-1/2	4-1/4	10-1/2	3/4 5/8
<b>AWMR-2 50-553</b>	15	6	3	3/4 10NC	1	7-1/2	3-3/4	1/2	9-1/2	5/8	14-1/2	7-1/4	17	3/4 5/8

**FIG. 56 – ISOLATOR DETAILS**

# WEIGHT DISTRIBUTION AND ISOLATOR MOUNTING POSITIONS

## Aluminium Fin and Black Fin Coils

### ALUMINUM FINNS, NEOPRENE MOUNT SELECTIONS – VMC TYPE RD-4 – (See Table below)

MODEL	A	B	C	D	E	F	G	H	I	J	K	L	M	N	O	P
YCAS0685	-4 Red	-4 Red	-4 Red	-3 Gray	-4 Red	-4 Red	-4 Grn	-4 Grn	-4 Red	-4 Grn	---	---	---	---	---	---
YCAS0775	-4 Red	-4 Red	-4 Grn	-4 Blk	-4 Blk	-4 Blk	-4 Red	-4 Red	-4 Grn	-4 Red	-4 Red	-4 Grn	---	---	---	---
YCAS0835	-4 Red	-4 Red	-4 Grn	-4 Blk	-4 Blk	-4 Blk	-4 Red	-4 Red	-4 Grn	-4 Red	-4 Red	-4 Grn	---	---	---	---
YCAS0905	-4 Red	-4 Red	-4 Grn	-4 Blk	-4 Blk	-4 Blk	-4 Red	-4 Red	-4 Grn	-4 Red	-4 Red	-4 Grn	---	---	---	---
YCAS0965	-4 Red	-4 Red	-4 Red	-4 Blk	-4 Blk	-4 Blk	-3 Gray	-3 Grn	-4 Red	-4 Red	-4 Grn	-4 Red	-4 Red	-4 Red	-3 Gray	-3 Grn
YCAS1065	-4 Red	-4 Red	-4 Red	-4 Blk	-4 Grn	-4 Blk	-4 Blk	-4 Grn	-4 Red	-4 Red	-4 Red	-4 Blk	-4 Grn	-4 Blk	-4 Blk	-4 Grn
YCAS1135	-4 Red	-4 Red	-4 Red	-4 Blk	-4 Grn	-4 Blk	-4 Blk	-4 Grn	-4 Red	-4 Red	-4 Red	-4 Blk	-4 Grn	-4 Blk	-4 Blk	-4 Grn
YCAS1215	-4 Red	-4 Red	-4 Red	-4 Blk	-4 Grn	-4 Blk	-4 Blk	-4 Grn	-4 Red	-4 Red	-4 Red	-4 Blk	-4 Grn	-4 Blk	-4 Blk	-4 Grn

### NEW DESIGN FOR TYPE RD-4 NEOPRENE MOUNTINGS.



**TYPE R OR RD  
NO BOLTING IS PREFERRED-**  
Type R or RD mountings are may be used without bolting under machines having no lateral or severe vertical motion.

29518A

### TYPE RD-3



**TYPE R OR RD  
IF BOLTING IS PREFERRED-**  
Type R or RD mountings are furnished with a tapped hole in the center. This enables the equipment to be bolted securely to the mounting.

29517A

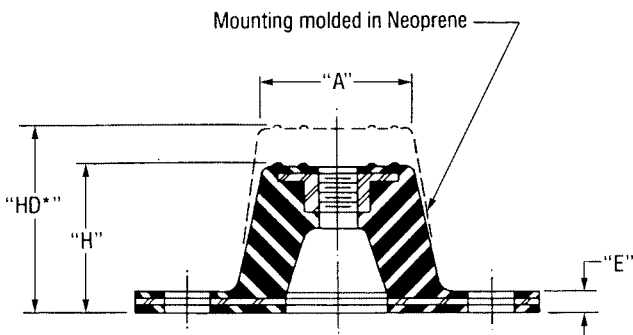

LD04033

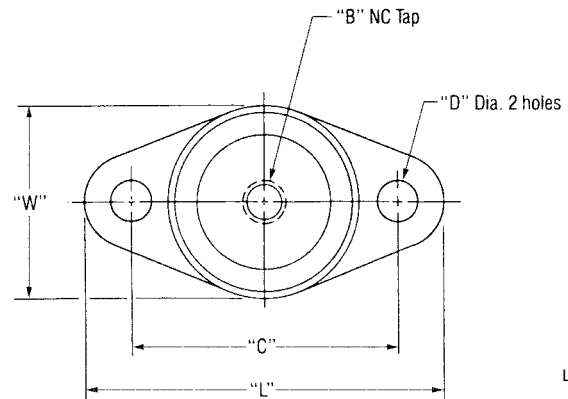

LD04033

TYPE	COLOR CODE	MAX. LOAD		DEFLECTION ins. (mm)	
		lbs.	(kg)	R	RD
R-3 OR RD-3	BLACK	250	(113.5)	0.25 (6.3)	0.50 (12.7)
	RED	525	(238.3)		
	GREEN	750	(340.5)		
	GRAY	1,100	(499.4)		
R-4 OR RD-4	BLACK	1,500	(681.0)	0.25 (6.3)	0.50 (12.7)
	RED	2,250	(1021.5)		
	GREEN	3,000	(1362.0)		
	GRAY	4,000	(1816.0)		

### DIMENSIONS: ins. (mm)

TYPE	L	W	H	*HD	A	B	C	D	E
R-3 OR RD-3	5-1/2" (139.7)	3-3/8" (85.8)	1-3/4" (44.4)	2-7/8" (73.2)	2-1/2" (63.5)	1/2" (12.7)	4-1/8" (104.8)	9/16" (14.4)	1/4" (6.3)
R-4 OR RD-4	6-1/4" (158.7)	4-5/8" (117.6)	1-5/8" (41.4)	2-3/4" (69.8)	3" (76.2)	1/2" (12.7)	5" (127.0)	9/16" (14.4)	3/8" (9.6)

\* HD dimension applies to double deflection Type RD mountings only.

# WEIGHT DISTRIBUTION AND ISOLATOR MOUNTING POSITIONS

## Copper Fin Condenser Coils

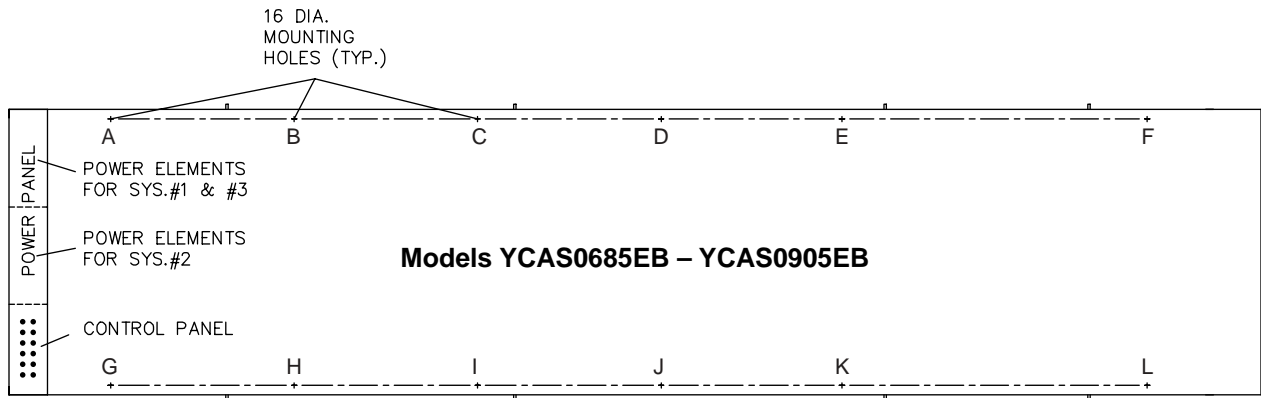

LD04126

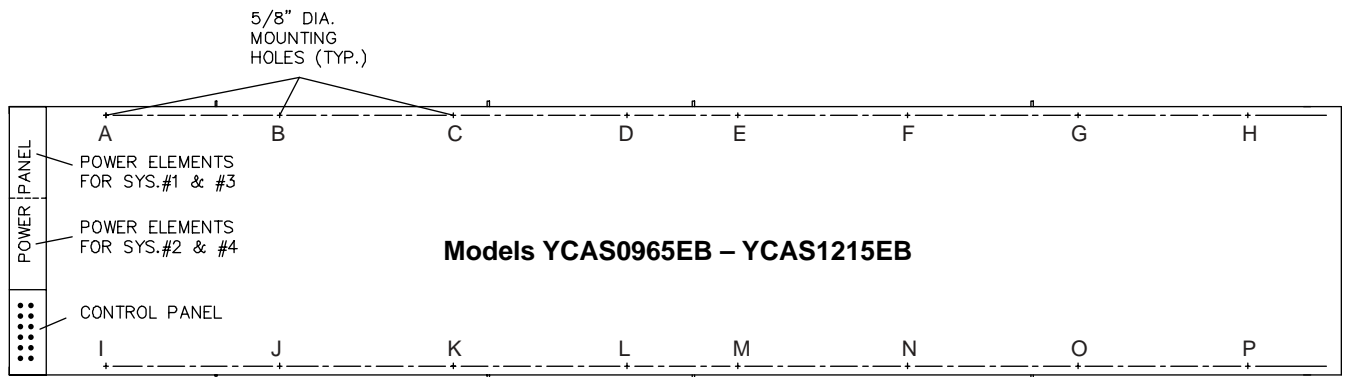

LD04127

### COPPER FIN WEIGHT DISTRIBUTION (kgs.) BY MODEL

MODEL	A	B	C	D	E	F	G	H	I	J	K	L	M	N	O	P	Total
YCAS0685	930	1,092	1,025	552	805	930	1,327	1,110	801	1,203	---	---	---	---	---	---	9,774
YCAS0775	938	861	1,098	691	606	730	938	861	1,234	801	777	1,137	---	---	---	---	10,673
YCAS0835	952	880	1,103	696	611	735	946	870	1,239	806	783	1,141	---	---	---	---	10,762
YCAS0905	956	885	1,121	704	613	737	956	885	1,245	811	786	1,144	---	---	---	---	10,842
YCAS0965	917	848	1,084	693	651	609	435	324	893	810	1,188	807	899	920	435	324	11,836
YCAS1065	930	892	899	630	1,148	697	641	1,233	951	855	761	709	1,225	620	641	1,233	14,064
YCAS1135	942	911	900	632	1,149	698	642	1,234	952	872	762	710	1,227	621	642	1,234	14,127
YCAS1215	941	910	920	639	1,149	698	641	1,235	973	871	778	719	1,227	621	641	1,235	14,197

# WEIGHT DISTRIBUTION AND ISOLATOR MOUNTING POSITIONS

## Copper Fin Condenser Coils

COPPER FIN S , 1" ISOLATOR SELECTIONS – VMC TYPE CP-2-XX – (See Table below)

MODEL	A	B	C	D	E	F	G	H	I	J	K	L	M	N	O	P
YCAS0685	2-31	2-32	2-32	2-27	2-31	2-31	2-35	2-32	2-28	2-35	---	---	---	---	---	---
YCAS0775	2-31	2-31	2-32	2-28	2-27	2-28	2-31	2-31	2-35	2-28	2-28	2-32	---	---	---	---
YCAS0835	2-31	2-31	2-32	2-28	2-27	2-28	2-31	2-31	2-35	2-28	2-28	2-32	---	---	---	---
YCAS0905	2-31	2-31	2-32	2-28	2-27	2-28	2-31	2-31	2-35	2-28	2-28	2-32	---	---	---	---
YCAS0965	2-31	2-31	2-32	2-27	2-27	2-27	2-26	2-25	2-31	2-28	2-32	2-28	2-31	2-31	2-26	2-25
YCAS1065	2-31	2-31	2-31	2-27	2-32	2-28	2-27	2-35	2-31	2-31	2-28	2-28	2-35	2-27	2-27	2-35
YCAS1135	2-31	2-31	2-31	2-27	2-32	2-28	2-27	2-35	2-31	2-31	2-28	2-28	2-35	2-27	2-27	2-35
YCAS1215	2-31	2-31	2-31	2-27	2-32	2-28	2-27	2-35	2-31	2-31	2-28	2-28	2-35	2-27	2-27	2-35

ISOLATOR TYPE & SIZE	MAX LOAD		DEFL.		SPRING COLOR
	lbs.	kg	in.	mm	
CP-2-26	1,200	544.3	1.17	29.7	Purple
CP-2-27	1,500	680.4	1.06	26.9	Orange
CP-2-28	1,800	816.4	1.02	25.9	Green
CP-2-31	2,200	997.9	0.83	21.0	Gray
CP-2-32	2,600	1,179.3	0.74	18.7	White
CP-2-35	3,000	1,360.8	0.70	17.7	Gold

### ISOLATOR DETAILS

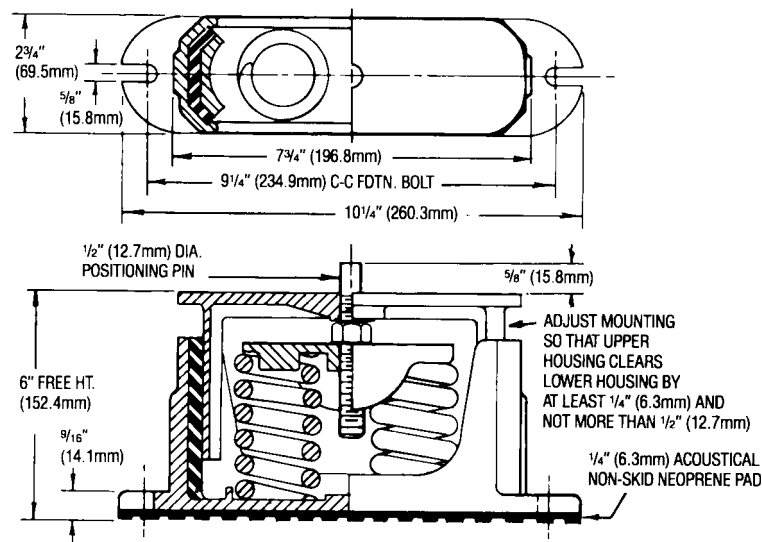

LD01089

FIG. 57 – CP-2-XX

## WEIGHT DISTRIBUTION AND ISOLATOR MOUNTING POSITIONS

### Copper Fin Condenser Coils

**COPPER FINNS, SEISMIC ISOLATOR SELECTIONS – VMC MODEL # AWMR-X-XX – (See Table below)**

MODEL	A	B	C	D	E	F	G	H	I	J	K	L	M	N	O	P
YCAS0685	1-553	2-531	2-530	1-531	1-552	1-553	2-532	2-531	1-552	2-532	---	---	---	---	---	---
YCAS0775	1-553	1-553	2-531	1-551	1-532	1-552	1-553	1-553	2-532	1-552	1-552	2-532	---	---	---	---
YCAS0835	1-553	1-553	2-531	1-551	1-532	1-552	1-553	1-553	2-532	1-552	1-552	2-532	---	---	---	---
YCAS0905	1-553	1-553	2-531	1-551	1-532	1-552	1-553	1-553	2-532	1-552	1-552	2-532	---	---	---	---
YCAS0965	1-553	1-552	2-531	2-521	2-521	1-532	1-530	1-521	1-553	1-552	2-532	1-553	2-53	1-553	1-530	1-530
YCAS1065	1-553	1-553	2-530	1-532	2-531	1-551	1-532	2-532	1-553	1-552	1-552	1-551	2-532	1-532	1-532	2-532
YCAS1135	1-553	1-553	2-530	1-532	2-531	1-551	1-532	2-532	1-553	1-553	1-552	1-551	2-532	1-532	1-532	2-532
YCAS1215	1-553	1-553	2-530	1-532	2-531	1-551	1-532	2-532	1-553	1-553	1-552	1-551	2-532	1-532	1-532	2-532

ISOLATOR TYPE & SIZE	MAX LOAD		DEFL.	
	lbs.	kg	in.	mm
AWMR-1-53	1000	453.6	2	51
AWMR-1-530	1150	521.6	2	51
AWMR-1-531	1276	578.8	2	51
AWMR-1-532	1500	680.4	2	51
AWMR-1-551	1676	760.2	2	51
AWMR-1-552	1900	861.8	2	51

ISOLATOR TYPE & SIZE	MAX LOAD		DEFL.	
	lbs.	kg	in.	mm
AWMR-1-553	2200	997.9	2	51
AWMR-2-520	1300	589.7	2	51
AWMR-2-521	1552	704.0	2	51
AWMR-2-53	2000	907.2	2	51
AWMR-1-530	2300	1043.3	2	51
AWMR-2-531	2552	1157.6	2	51
AWMR-2-532	3000	1360.8	2	51

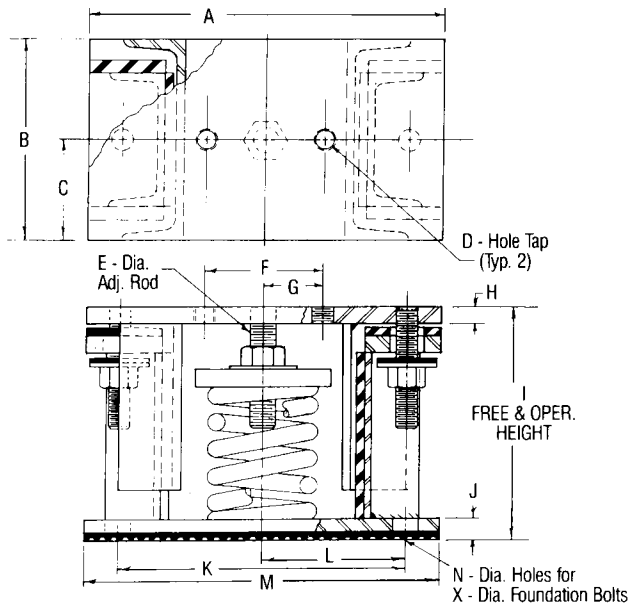

LD02973

**AWMR-1-XXX**

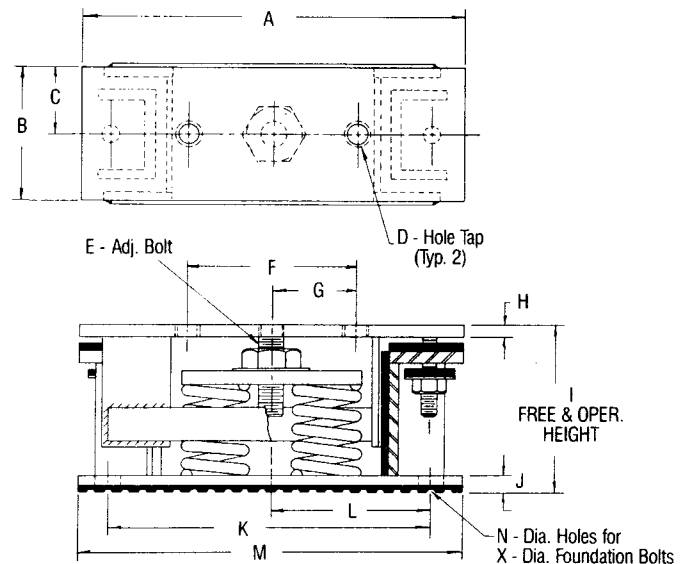

LD02974

**AWMR-2-XXX**

**DIMENSIONS - In.**

	A	B	C	D	E	F	G	H	I	J	K	L	M	N/X
<b>AWMR-1 50-553</b>	10-1/2	6	3	5/8 11NC	3/4	3-1/2	1-3/4	1/2	9	5/8	8-1/2	4-1/4	10-1/2	3/4 5/8
<b>AWMR-2 50-553</b>	15	6	3	3/4 10NC	1	7-1/2	3-3/4	1/2	9-1/2	5/8	14-1/2	7-1/4	17	3/4 5/8

**FIG. 58 – ISOLATOR DETAILS**

# WEIGHT DISTRIBUTION AND ISOLATOR MOUNTING POSITIONS

## Copper Fin Condenser Coils

### COPPER FINNS, NEOPRENE MOUNT SELECTIONS – VMC TYPE RD-X – (See Table below)

MODEL	A	B	C	D	E	F	G	H	I	J	K	L	M	N	O	P
YCAS0685	-4 Red	-4 Grn	-4 Grn	-4 Blk	-4 Red	-4 Red	-4 Grn	-4 Grn	-4 Red	-4 Grn	---	---	---	---	---	---
YCAS0775	-4 Red	-4 Red	-4 Grn	-4 Red	-4 Blk	-4 Red	-4 Red	-4 Red	-4 Grn	-4 Red	-4 Red	-4 Grn	---	---	---	---
YCAS0835	-4 Red	-4 Red	-4 Grn	-4 Red	-4 Blk	-4 Red	-4 Red	-4 Red	-4 Grn	-4 Red	-4 Red	-4 Grn	---	---	---	---
YCAS0905	-4 Red	-4 Red	-4 Grn	-4 Red	-4 Blk	-4 Red	-4 Red	-4 Red	-4 Grn	-4 Red	-4 Red	-4 Grn	---	---	---	---
YCAS0965	-4 Red	-4 Red	-4 Grn	-4 Blk	-4 Blk	-4 Blk	-3 Gray	-3 Grn	-4 Red	-4 Red	-4 Grn	-4 Red	-4 Red	-4 Red	-3 Gray	-3 Grn
YCAS1065	-4 Red	-4 Red	-4 Red	-4 Blk	-4 Grn	-4 Red	-4 Blk	-4 Grn	-4 Red	-4 Red	-4 Red	-4 Red	-4 Grn	-4 Blk	-4 Blk	-4 Grn
YCAS1135	-4 Red	-4 Red	-4 Red	-4 Blk	-4 Grn	-4 Red	-4 Blk	-4 Grn	-4 Red	-4 Red	-4 Red	-4 Red	-4 Grn	-4 Blk	-4 Blk	-4 Grn
YCAS1215	-4 Red	-4 Red	-4 Red	-4 Blk	-4 Grn	-4 Red	-4 Blk	-4 Grn	-4 Red	-4 Red	-4 Red	-4 Red	-4 Grn	-4 Blk	-4 Blk	-4 Grn

### NEW DESIGN FOR TYPE RD-4 NEOPRENE MOUNTINGS.



29518A

### TYPE RD-3



29517A

**TYPE R OR RD  
NO BOLTING IS PREFERRED--**  
Type R or RD mountings are may be used without bolting under machines having no lateral or severe vertical motion.

**TYPE R OR RD  
IF BOLTING IS PREFERRED--**  
Type R or RD mountings are furnished with a tapped hole in the center. This enables the equipment to be bolted securely to the mounting.

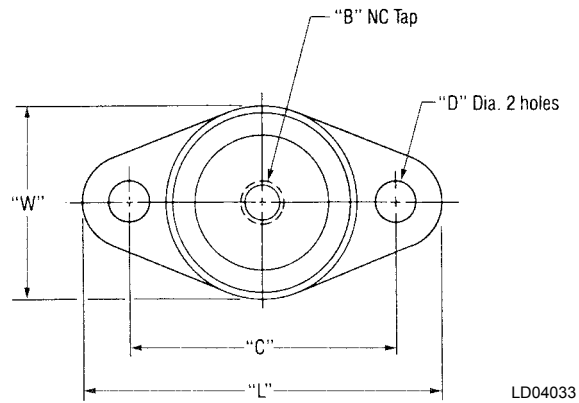
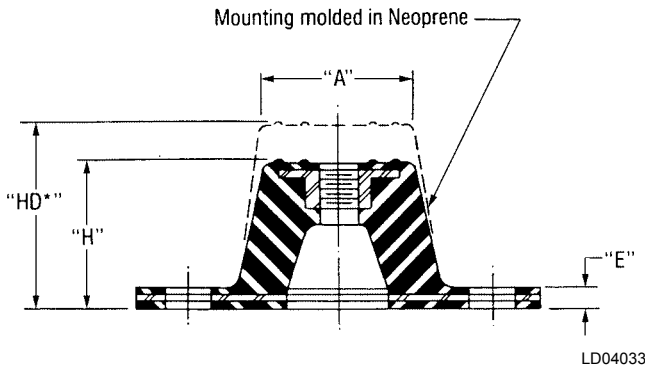

TYPE	COLOR CODE	MAX. LOAD		DEFLECTION ins. (mm)	
		lbs.	(kg)	R	RD
R-3 OR RD-3	BLACK	250	(113.5)	0.25 (6.3)	0.50 (12.7)
	RED	525	(238.3)		
	GREEN	750	(340.5)		
	GRAY	1,100	(499.4)		
R-4 OR RD-4	BLACK	1,500	(681.0)	0.25 (6.3)	0.50 (12.7)
	RED	2,250	(1,021.5)		
	GREEN	3,000	(1,362.0)		
	GRAY	4,000	(1,816.0)		

### DIMENSIONS: ins. (mm)

TYPE	L	W	H	*HD	A	B	C	D	E
R-3 OR RD-3	5-1/2" (139.7)	3-3/8" (85.8)	1-3/4" (44.4)	2-7/8" (73.2)	2-1/2" (63.5)	1/2" (12.7)	4-1/8" (104.8)	9/16" (14.4)	1/4" (6.3)
R-4 OR RD-4	6-1/4" (158.7)	4-5/8" (117.6)	1-5/8" (41.4)	2-3/4" (69.8)	3" (76.2)	1/2" (12.7)	5" (127.0)	9/16" (14.4)	3/8" (9.6)

\* HD dimension applies to double deflection Type RD mountings only.

# WEIGHT DISTRIBUTION AND ISOLATOR MOUNTING POSITIONS

## Aluminium Fin and Black Fin Condenser Coils with Silencer Kit

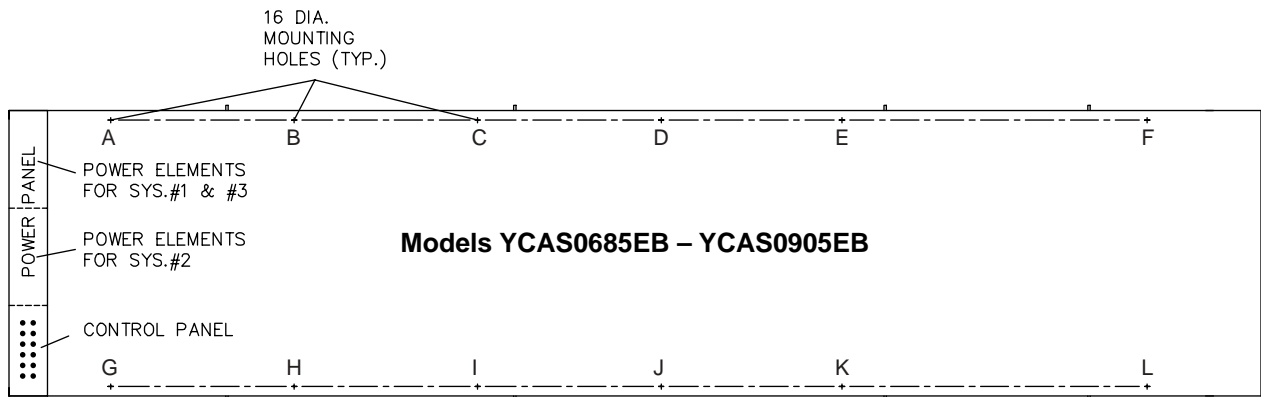

LD04126

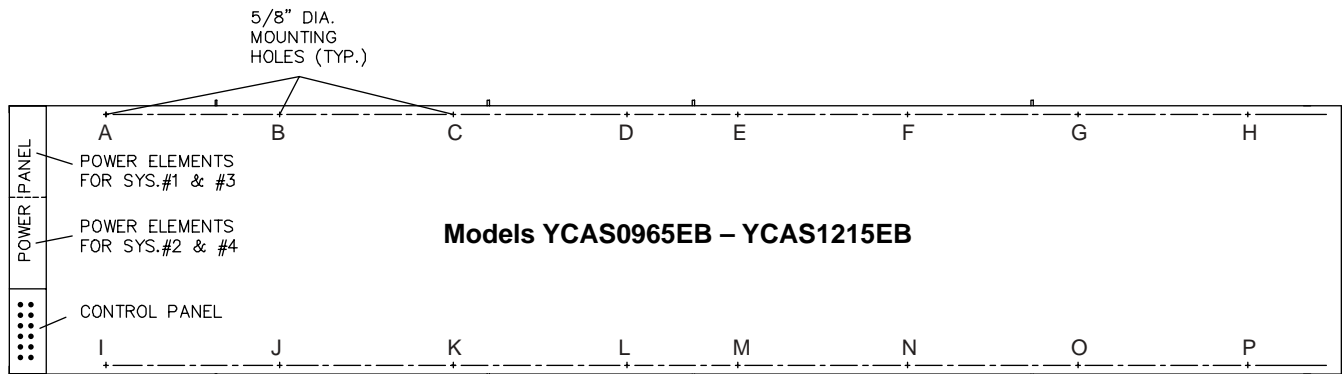

LD04127

### ALUMINUM FIN WITH OPTIONAL SILENCER KIT WEIGHT DISTRIBUTION (kgs.) BY MODEL

MODEL	A	B	C	D	E	F	G	H	I	J	K	L	M	N	O	P	Total
YCAS0685	930	1,092	1,025	552	805	930	1,327	1,110	801	1,203	---	---	---	---	---	---	9,774
YCAS0775	938	861	1,098	691	606	730	938	861	1,234	801	777	1,137	---	---	---	---	10,673
YCAS0835	952	880	1,103	696	611	735	946	870	1,239	806	783	1,141	---	---	---	---	10,762
YCAS0905	956	885	1,121	704	613	737	956	885	1,245	811	786	1,144	---	---	---	---	10,842
YCAS0965	917	848	1,084	693	651	609	435	324	893	810	1,188	807	899	920	435	324	11,836
YCAS1065	930	892	899	630	1,148	697	641	1,233	951	855	761	709	1,225	620	641	1,233	14,064
YCAS1135	942	911	900	632	1,149	698	642	1,234	952	872	762	710	1,227	621	642	1,234	14,127
YCAS1215	941	910	920	639	1,149	698	641	1,235	973	871	778	719	1,227	621	641	1,235	14,197

# WEIGHT DISTRIBUTION AND ISOLATOR MOUNTING POSITIONS

## Aluminium Fin and Black Fin Condenser Coils with Silencer Kit

ALUMINUM FIN WITH OPTIONAL SILENCER KIT, 1" ISOLATOR SELECTIONS – VMC TYPE CP-2-XX –  
(See Table below)

MODEL	A	B	C	D	E	F	G	H	I	J	K	L	M	N	O	P
YCAS0685	2-31	2-32	2-32	2-27	2-31	2-31	2-35	2-32	2-28	2-35	---	---	---	---	---	---
YCAS0775	2-31	2-31	2-32	2-28	2-27	2-28	2-31	2-31	2-35	2-28	2-28	2-32	---	---	---	---
YCAS0835	2-31	2-31	2-32	2-28	2-27	2-28	2-31	2-31	2-35	2-28	2-28	2-32	---	---	---	---
YCAS0905	2-31	2-31	2-32	2-28	2-27	2-28	2-31	2-31	2-35	2-28	2-28	2-32	---	---	---	---
YCAS0965	2-31	2-31	2-32	2-27	2-27	2-27	2-26	2-25	2-31	2-28	2-32	2-28	2-31	2-31	2-26	2-25
YCAS1065	2-31	2-31	2-31	2-27	2-32	2-28	2-27	2-35	2-31	2-31	2-28	2-28	2-35	2-27	2-27	2-35
YCAS1135	2-31	2-31	2-31	2-27	2-32	2-28	2-27	2-35	2-31	2-31	2-28	2-28	2-35	2-27	2-27	2-35
YCAS1215	2-31	2-31	2-31	2-27	2-32	2-28	2-27	2-35	2-31	2-31	2-28	2-28	2-35	2-27	2-27	2-35

ISOLATOR TYPE & SIZE	MAX LOAD		DEFL.		SPRING COLOR
	lbs.	kg	in.	mm	
CP-2-26	1,200	544.3	1.17	29.7	Purple
CP-2-27	1,500	680.4	1.06	26.9	Orange
CP-2-28	1,800	816.4	1.02	25.9	Green
CP-2-31	2,200	997.9	0.83	21.0	Gray
CP-2-32	2,600	1,179.3	0.74	18.7	White
CP-2-35	3,000	1,360.8	0.70	17.7	Gold

### ISOLATOR DETAILS

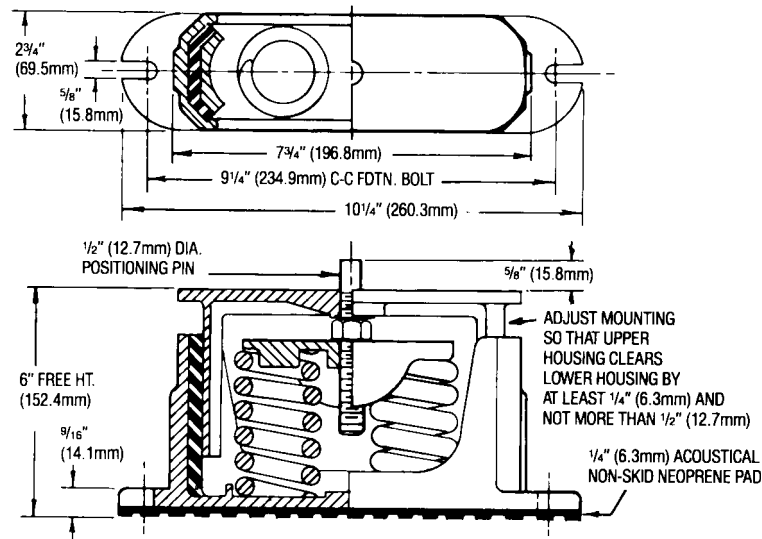

LD01089

FIG. 59 – CP-2-XX

## WEIGHT DISTRIBUTION AND ISOLATOR MOUNTING POSITIONS

### Aluminium Fin and Black Fin Condenser Coils with Silencer Kit

**ALUMINUM FIN WITH OPTIONAL SILENCER KIT, SEISMIC ISOLATOR SELECTIONS – VMC MODEL # AWMR-X-XX**  
(See Table below)

MODEL	A	B	C	D	E	F	G	H	I	J	K	L	M	N	O	P
YCAS0685	1-553	2-531	2-530	1-531	1-552	1-553	2-532	2-531	1-552	2-532	---	---	---	---	---	---
YCAS0775	1-553	1-553	2-531	1-551	1-532	1-552	1-553	1-553	2-532	1-552	1-552	2-532	---	---	---	---
YCAS0835	1-553	1-553	2-531	1-551	1-532	1-552	1-553	1-553	2-532	1-552	1-552	2-532	---	---	---	---
YCAS0905	1-553	1-553	2-531	1-551	1-532	1-552	1-553	1-553	2-532	1-552	1-552	2-532	---	---	---	---
YCAS0965	1-553	1-552	2-531	2-521	2-521	1-532	1-530	1-521	1-553	1-552	2-532	1-553	2-53	1-553	1-530	1-530
YCAS1065	1-553	1-553	2-530	1-532	2-531	1-551	1-532	2-532	1-553	1-552	1-552	1-551	2-532	1-532	1-532	2-532
YCAS1135	1-553	1-553	2-530	1-532	2-531	1-551	1-532	2-532	1-553	1-553	1-552	1-551	2-532	1-532	1-532	2-532
YCAS1215	1-553	1-553	2-530	1-532	2-531	1-551	1-532	2-532	1-553	1-553	1-552	1-551	2-532	1-532	1-532	2-532

ISOLATOR TYPE & SIZE	MAX LOAD		DEFL.	
	lbs.	kg	in.	mm
AWMR-1-53	1000	453.6	2	51
AWMR-1-530	1150	521.6	2	51
AWMR-1-531	1276	578.8	2	51
AWMR-1-532	1500	680.4	2	51
AWMR-1-551	1676	760.2	2	51
AWMR-1-552	1900	861.8	2	51

ISOLATOR TYPE & SIZE	MAX LOAD		DEFL.	
	lbs.	kg	in.	mm
AWMR-1-553	2200	997.9	2	51
AWMR-2-520	1300	589.7	2	51
AWMR-2-521	1552	704.0	2	51
AWMR-2-53	2000	907.2	2	51
AWMR-1-530	2300	1043.3	2	51
AWMR-2-531	2552	1157.6	2	51
AWMR-2-532	3000	1360.8	2	51

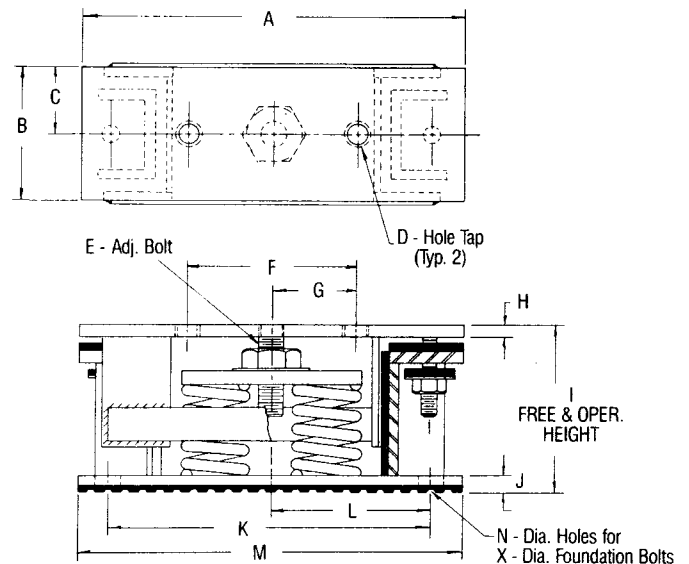
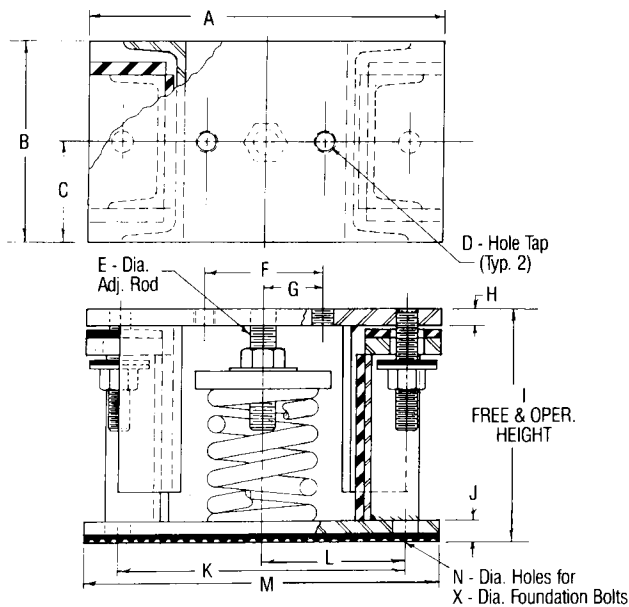

**AWMR-1-XXX**

LD02973

**AWMR-2-XXX**

LD02974

**DIMENSIONS - In.**

	A	B	C	D	E	F	G	H	I	J	K	L	M	N/X
<b>AWMR-1 50-553</b>	10-1/2	6	3	5/8 11NC	3/4	3-1/2	1-3/4	1/2	9	5/8	8-1/2	4-1/4	10-1/2	3/4 5/8
<b>AWMR-2 50-553</b>	15	6	3	3/4 10NC	1	7-1/2	3-3/4	1/2	9-1/2	5/8	14-1/2	7-1/4	17	3/4 5/8

**FIG. 60 – ISOLATOR DETAILS**

# WEIGHT DISTRIBUTION AND ISOLATOR MOUNTING POSITIONS

ALUMINUM FIN WITH OPTIONAL SILENCER KIT, NEOPRENE MOUNT SELECTIONS – VMC TYPE RD-X –  
(See Table below)

MODEL	A	B	C	D	E	F	G	H	I	J	K	L	M	N	O	P
YCAS0685	-4 Red	-4 Grn	-4 Grn	-4 Blk	-4 Red	-4 Red	-4 Grn	-4 Grn	-4 Red	-4 Grn	---	---	---	---	---	---
YCAS0775	-4 Red	-4 Red	-4 Grn	-4 Red	-4 Blk	-4 Red	-4 Red	-4 Red	-4 Grn	-4 Red	-4 Red	-4 Grn	---	---	---	---
YCAS0835	-4 Red	-4 Red	-4 Grn	-4 Red	-4 Blk	-4 Red	-4 Red	-4 Red	-4 Grn	-4 Red	-4 Red	-4 Grn	---	---	---	---
YCAS0905	-4 Red	-4 Red	-4 Grn	-4 Red	-4 Blk	-4 Red	-4 Red	-4 Red	-4 Grn	-4 Red	-4 Red	-4 Grn	---	---	---	---
YCAS0965	-4 Red	-4 Red	-4 Grn	-4 Blk	-4 Blk	-4 Blk	-3 Gray	-3 Grn	-4 Red	-4 Red	-4 Grn	-4 Red	-4 Red	-4 Red	-3 Gray	-3 Grn
YCAS1065	-4 Red	-4 Red	-4 Red	-4 Blk	-4 Grn	-4 Red	-4 Blk	-4 Grn	-4 Red	-4 Red	-4 Red	-4 Red	-4 Grn	-4 Blk	-4 Blk	-4 Grn
YCAS1135	-4 Red	-4 Red	-4 Red	-4 Blk	-4 Grn	-4 Red	-4 Blk	-4 Grn	-4 Red	-4 Red	-4 Red	-4 Red	-4 Grn	-4 Blk	-4 Blk	-4 Grn
YCAS1215	-4 Red	-4 Red	-4 Red	-4 Blk	-4 Grn	-4 Red	-4 Blk	-4 Grn	-4 Red	-4 Red	-4 Red	-4 Red	-4 Grn	-4 Blk	-4 Blk	-4 Grn

## NEW DESIGN FOR TYPE RD-4 NEOPRENE MOUNTINGS.



29518A

**TYPE R OR RD  
NO BOLTING IS PREFERRED--**  
Type R or RD mountings are may be used without bolting under machines having no lateral or severe vertical motion.

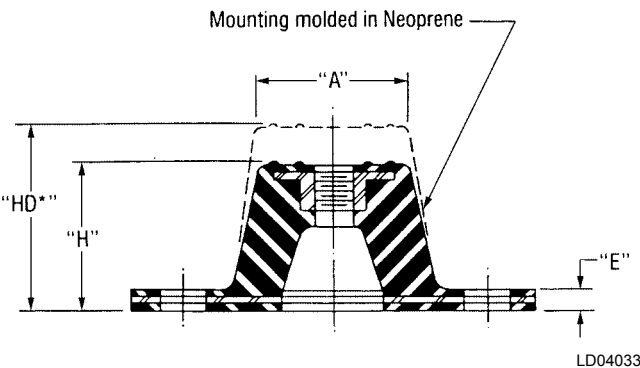

## TYPE RD-3



29517A

**TYPE R OR RD  
IF BOLTING IS PREFERRED--**  
Type R or RD mountings are furnished with a tapped hole in the center. This enables the equipment to be bolted securely to the mounting.

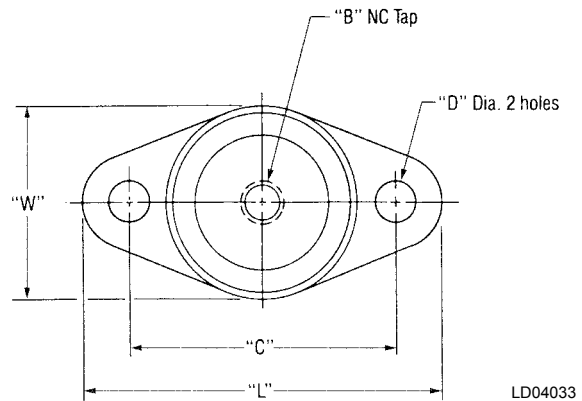

TYPE	COLOR CODE	MAX. LOAD		DEFLECTION ins. (mm)	
		lbs.	(kg)	R	RD
R-3 OR RD-3	BLACK	250	(113.5)	0.25 (6.3)	0.50 (12.7)
	RED	525	(238.3)		
	GREEN	750	(340.5)		
	GRAY	1,100	(499.4)		
R-4 OR RD-4	BLACK	1,500	(681.0)	0.25 (6.3)	0.50 (12.7)
	RED	2,250	(1,021.5)		
	GREEN	3,000	(1,362.0)		
	GRAY	4,000	(1,816.0)		

### DIMENSIONS: ins. (mm)

TYPE	L	W	H	*HD	A	B	C	D	E
R-3 OR RD-3	5-1/2" (139.7)	3-3/8" (85.8)	1-3/4" (44.4)	2-7/8" (73.2)	2-1/2" (63.5)	1/2" (12.7)	4-1/8" (104.8)	9/16" (14.4)	1/4" (6.3)
R-4 OR RD-4	6-1/4" (158.7)	4-5/8" (117.6)	1-5/8" (41.4)	2-3/4" (69.8)	3" (76.2)	1/2" (12.7)	5" (127.0)	9/16" (14.4)	3/8" (9.6)

\* HD dimension applies to double deflection Type RD mountings only.

# WEIGHT DISTRIBUTION AND ISOLATOR MOUNTING POSITIONS

## Copper Fin Condenser Coils with Silencer Kit

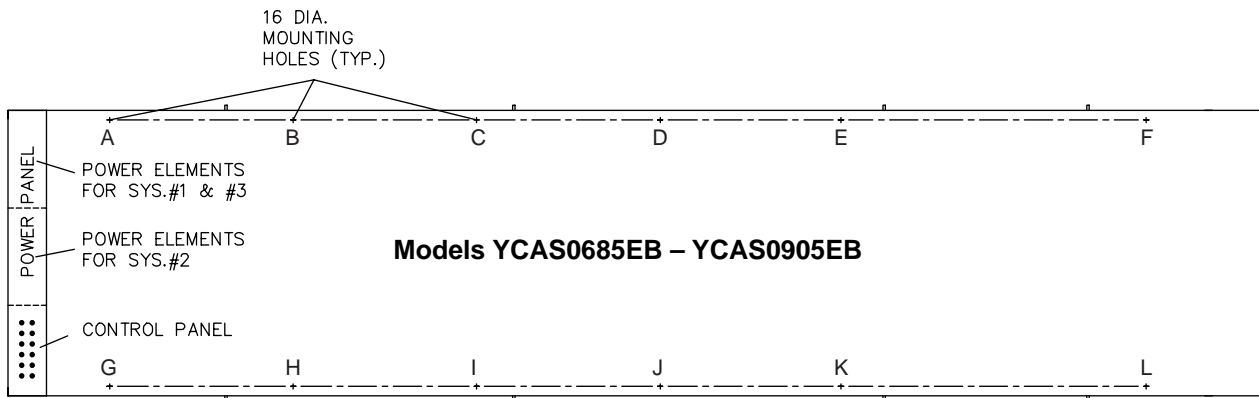

LD04126

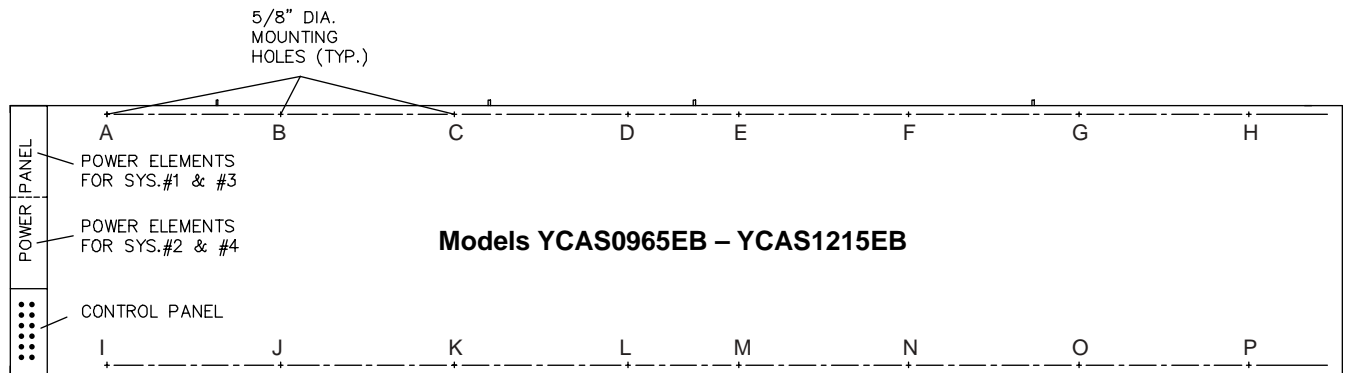

LD04127

### COPPER FIN WITH OPTIONAL SILENCER KIT WEIGHT DISTRIBUTION (kgs.) BY MODEL

MODEL	A	B	C	D	E	F	G	H	I	J	K	L	M	N	O	P	Total
YCAS0685	998	1,160	1,093	620	927	1,021	1,373	1,178	881	1,314	---	---	---	---	---	---	10,564
YCAS0775	1,007	929	1,159	766	686	841	1,007	929	1,289	882	870	1,235	---	---	---	---	11,599
YCAS0835	1,020	948	1,164	771	598	939	1,014	938	1,293	888	876	1,239	---	---	---	---	11,688
YCAS0905	1,024	953	1,182	779	694	847	1,024	953	1,300	893	878	1,241	---	---	---	---	11,768
YCAS0965	985	916	1,145	767	726	670	503	447	961	878	1,243	889	980	975	503	447	13,034
YCAS1065	998	960	960	705	1,222	758	709	1,355	976	923	816	791	1,307	674	709	1,355	15,218
YCAS1135	1,010	979	961	707	1,224	759	710	1,356	987	940	816	792	1,308	675	710	1,356	15,291
YCAS1215	1,009	978	981	714	1,224	759	709	1,357	986	939	832	801	1,309	675	709	1,357	15,340

# WEIGHT DISTRIBUTION AND ISOLATOR MOUNTING POSITIONS

## Copper Fin Condenser Coils with Silencer Kit

### COPPER FINNS WITH OPTIONAL SILENCER KIT, 1" ISOLATOR SELECTIONS – VMC TYPE CP-2-XX (See Table 3, page 43)

MODEL	A	B	C	D	E	F	G	H	I	J	K	L	M	N	O	P
YCAS0685	2-31	2-32	2-32	2-27	2-31	2-32	2-35	2-32	2-31	2-35	---	---	---	---	---	---
YCAS0775	2-32	2-31	2-32	2-28	2-28	2-31	2-32	2-31	2-35	2-31	2-31	2-35	---	---	---	---
YCAS0835	2-32	2-31	2-32	2-28	2-28	2-31	2-32	2-31	2-35	2-31	2-31	2-35	---	---	---	---
YCAS0905	2-32	2-31	2-32	2-28	2-28	2-31	2-32	2-31	2-35	2-31	2-31	2-35	---	---	---	---
YCAS0965	2-31	2-31	2-32	2-28	2-28	2-27	2-26	2-26	2-31	2-31	2-35	2-31	2-31	2-31	2-26	2-26
YCAS1065	2-32	2-31	2-31	2-28	2-35	2-28	2-28	2-35	2-31	2-31	2-31	2-28	2-35	2-27	2-28	2-35
YCAS1135	2-32	2-31	2-31	2-28	2-35	2-28	2-28	2-35	2-31	2-31	2-31	2-28	2-35	2-27	2-28	2-35
YCAS1215	2-32	2-31	2-31	2-28	2-35	2-28	2-28	2-35	2-31	2-31	2-31	2-28	2-35	2-27	2-28	2-35

ISOLATOR TYPE & SIZE	MAX LOAD		DEFL.		SPRING COLOR
	lbs.	kg	in.	mm	
CP-2-26	1,200	544.3	1.17	29.7	Purple
CP-2-27	1,500	680.4	1.06	26.9	Orange
CP-2-28	1,800	816.4	1.02	25.9	Green
CP-2-31	2,200	997.9	0.83	21.0	Gray
CP-2-32	2,600	1,179.3	0.74	18.7	White
CP-2-35	3,000	1,360.8	0.70	17.7	Gold

### ISOLATOR DETAILS

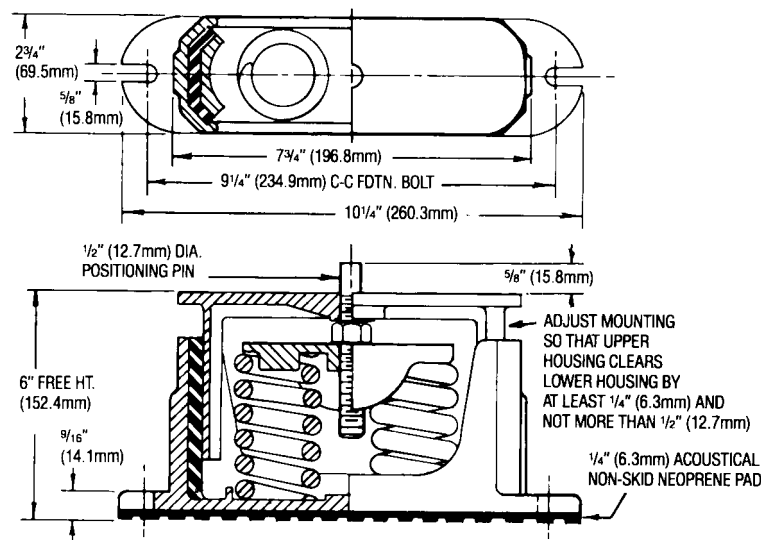

FIG. 61 – CP-2-XX

## WEIGHT DISTRIBUTION AND ISOLATOR MOUNTING POSITIONS

### Copper Fin Condenser Coils with Silencer Kit

**COPPER FINNS WITH OPTIONAL SILENCER KIT, SEISMIC ISOLATOR SELECTIONS – VMC MODEL # AWMR-X-XX**  
– (See Table below)

MODEL	A	B	C	D	E	F	G	H	I	J	K	L	M	N	O	P
YCAS0685	1-553	2-531	2-531	1-532	1-553	2-530	2-532	2-532	1-553	2-532	---	---	---	---	---	---
YCAS0775	2-530	1-553	2-532	1-552	1-551	1-552	2-530	1-553	2-532	1-553	1-553	2-532	---	---	---	---
YCAS0835	2-530	1-553	2-532	1-552	1-551	1-552	2-530	1-553	2-532	1-553	1-553	2-532	---	---	---	---
YCAS0905	2-530	1-553	2-532	1-552	1-551	1-552	2-530	1-553	2-532	1-553	1-553	2-532	---	---	---	---
YCAS0965	1-553	1-553	2-531	2-53	2-53	1-532	1-530	1-530	1-553	1-553	2-532	2-53	2-530	2-530	1-530	1-530
YCAS1065	2-530	1-553	1-553	1-551	2-532	1-551	1-551	2-532	1-553	1-553	2-53	1-552	2-532	1-532	1-551	2-532
YCAS1135	2-530	1-553	1-553	1-551	2-532	1-551	1-551	2-532	1-553	1-553	2-53	1-552	2-532	1-532	1-551	2-532
YCAS1215	2-530	1-553	1-553	1-551	2-532	1-551	1-551	2-532	1-553	1-553	2-53	1-552	2-532	1-532	1-551	2-532

ISOLATOR TYPE & SIZE	MAX LOAD		DEFL.	
	lbs.	kg	in.	mm
AWMR-1-53	1000	453.6	2	51
AWMR-1-530	1150	521.6	2	51
AWMR-1-531	1276	578.8	2	51
AWMR-1-532	1500	680.4	2	51
AWMR-1-551	1676	760.2	2	51
AWMR-1-552	1900	861.8	2	51

ISOLATOR TYPE & SIZE	MAX LOAD		DEFL.	
	lbs.	kg	in.	mm
AWMR-1-553	2200	997.9	2	51
AWMR-2-520	1300	589.7	2	51
AWMR-2-521	1552	704.0	2	51
AWMR-2-53	2000	907.2	2	51
AWMR-1-530	2300	1043.3	2	51
AWMR-2-531	2552	1157.6	2	51
AWMR-2-532	3000	1360.8	2	51

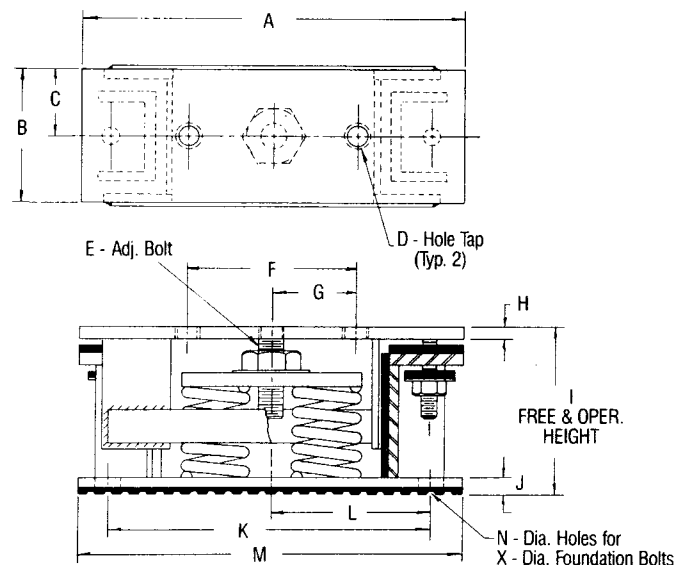
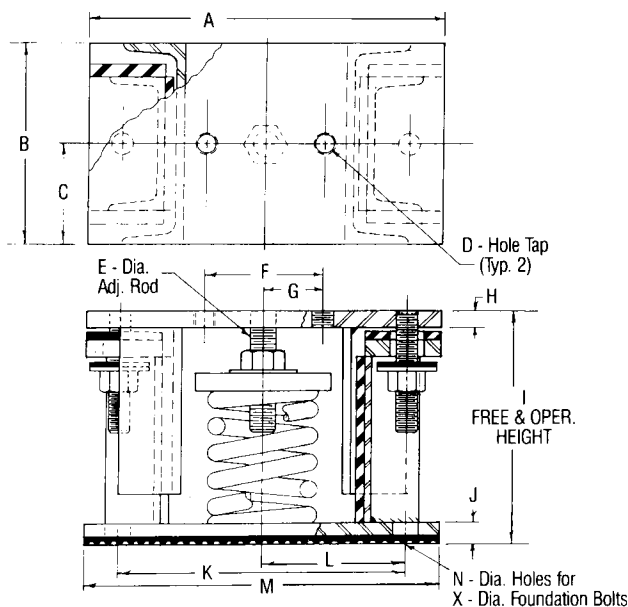

LD02973

LD02974

#### AWMR-1-XXX

#### AWMR-2-XXX

DIMENSIONS - In.

	A	B	C	D	E	F	G	H	I	J	K	L	M	N/X
AWMR-1 50-553	10-1/2	6	3	5/8 11NC	3/4	3-1/2	1-3/4	1/2	9	5/8	8-1/2	4-1/4	10-1/2	3/4 5/8
AWMR-2 50-553	15	6	3	3/4 10NC	1	7-1/2	3-3/4	1/2	9-1/2	5/8	14-1/2	7-1/4	17	3/4 5/8

FIG. 62 – ISOLATOR DETAILS

# WEIGHT DISTRIBUTION AND ISOLATOR MOUNTING POSITIONS

## Copper Fin Condenser Coils with Silencer Kit

**COPPER FINNS WITH OPTIONAL SILENCER KIT, NEOPRENE MOUNT SELECTIONS – VMC TYPE RD-X – (See Table below)**

MODEL	A	B	C	D	E	F	G	H	I	J	K	L	M	N	O	P
YCAS0685	-4 Red	-4 Grn	-4 Grn	-4 Blk	-4 Red	-4 Red	-4 Grn	-4 Grn	-4 Red	-4 Grn	---	---	---	---	---	---
YCAS0775	-4 Red	-4 Red	-4 Grn	-4 Red	-4 Blk	-4 Red	-4 Red	-4 Red	-4 Grn	-4 Red	-4 Red	-4 Grn	---	---	---	---
YCAS0835	-4 Red	-4 Red	-4 Grn	-4 Red	-4 Blk	-4 Red	-4 Red	-4 Red	-4 Grn	-4 Red	-4 Red	-4 Grn	---	---	---	---
YCAS0905	-4 Grn	-4 Red	-4 Grn	-4 Red	-4 Red	-4 Red	-4 Grn	-4 Red	-4 Grn	-4 Red	-4 Red	-4 Grn	---	---	---	---
YCAS0965	-4 Red	-4 Red	-4 Grn	-4 Red	-4 Red	-4 Blk	-4 Blk	-3 Gray	-4 Red	-4 Red	-4 Grn	-4 Red	-4 Red	-4 Red	-4 Blk	-3 Gray
YCAS1065	-4 Red	-4 Red	-4 Red	-4 Red	-4 Grn	-4 Red	-4 Red	-4 Grn	-4 Red	-4 Red	-4 Red	-4 Red	-4 Grn	-4 Blk	-4 Red	-4 Gray
YCAS1135	-4 Red	-4 Red	-4 Red	-4 Red	-4 Grn	-4 Red	-4 Red	-4 Grn	-4 Red	-4 Red	-4 Red	-4 Red	-4 Gray	-4 Blk	-4 Red	-4 Gray
YCAS1215	-4 Red	-4 Red	-4 Red	-4 Red	-4 Grn	-4 Red	-4 Red	-4 Grn	-4 Red	-4 Red	-4 Red	-4 Red	-4 Gray	-4 Blk	-4 Red	-4 Gray

### NEW DESIGN FOR TYPE RD-4 NEOPRENE MOUNTINGS.



29518A

### TYPE RD-3



29517A

**TYPE R OR RD  
NO BOLTING IS PREFERRED--**  
Type R or RD mountings are may be used without bolting under machines having no lateral or severe vertical motion.

**TYPE R OR RD  
IF BOLTING IS PREFERRED--**  
Type R or RD mountings are furnished with a tapped hole in the center. This enables the equipment to be bolted securely to the mounting.

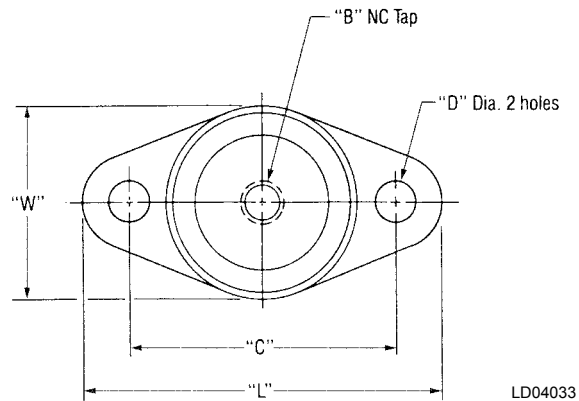
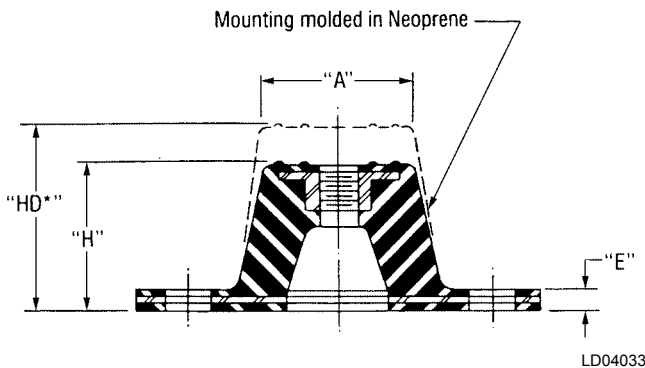

TYPE	COLOR CODE	MAX. LOAD		DEFLECTION ins. (mm)	
		lbs.	(kg)	R	RD
R-3 OR RD-3	BLACK	250	(113.5)	0.25 (6.3)	0.50 (12.7)
	RED	525	(238.3)		
	GREEN	750	(340.5)		
	GRAY	1,100	(499.4)		
R-4 OR RD-4	BLACK	1,500	(681.0)	0.25 (6.3)	0.50 (12.7)
	RED	2,250	(1,021.5)		
	GREEN	3,000	(1,362.0)		
	GRAY	4,000	(1,816.0)		

**DIMENSIONS: ins. (mm)**

TYPE	L	W	H	*HD	A	B	C	D	E
R-3 OR RD-3	5-1/2" (139.7)	3-3/8" (85.8)	1-3/4" (44.4)	2-7/8" (73.2)	2-1/2" (63.5)	1/2" (12.7)	4-1/8" (104.8)	9/16" (14.4)	1/4" (6.3)
R-4 OR RD-4	6-1/4" (158.7)	4-5/8" (117.6)	1-5/8" (41.4)	2-3/4" (69.8)	3" (76.2)	1/2" (12.7)	5" (127.0)	9/16" (14.4)	3/8" (9.6)

\* HD dimension applies to double deflection Type RD mountings only.

## INSTALLATION INSTRUCTIONS FOR VMC SERIES AWR/AWMR AND CP RESTRAINED MOUNTINGS

1. Floor should be level and smooth.
2. For indoor applications, isolators do not normally require bolting. If necessary, anchor isolators to floor through bolt holes in base plate.  
**IMPORTANT: Isolators must be bolted to substructure and equipment to isolators when used under outdoor equipment exposed to wind forces.**
3. Lubricate threads of adjusting bolt. Loosen hold down bolts to allow for isolator adjustment.
4. Block the equipment 1/4" higher than the specified free height of the isolator. To use the isolator as blocking for the equipment, insert a 1/4" shim between the upper load plate and vertical uprights. Lower the equipment on the blocking or shimmed isolators.
5. Complete piping and fill equipment with water, refrigerant, etc.
6. Turn leveling bolt of first isolator four full revolutions and proceed to each mount in turn.
7. Continue turning leveling bolts until equipment is fully supported by all mountings and equipment is raised free of the spacer blocks or shims. Remove blocks or shims.
8. Turn leveling bolt of all mountings in either direction in order to level the installation.
9. Tighten nuts on hold down bolts to permit a clearance of 1/8" between resilient washer and underside of channel cap plate.
10. Installation is now complete.

### REFRIGERANT FLOW DIAGRAM

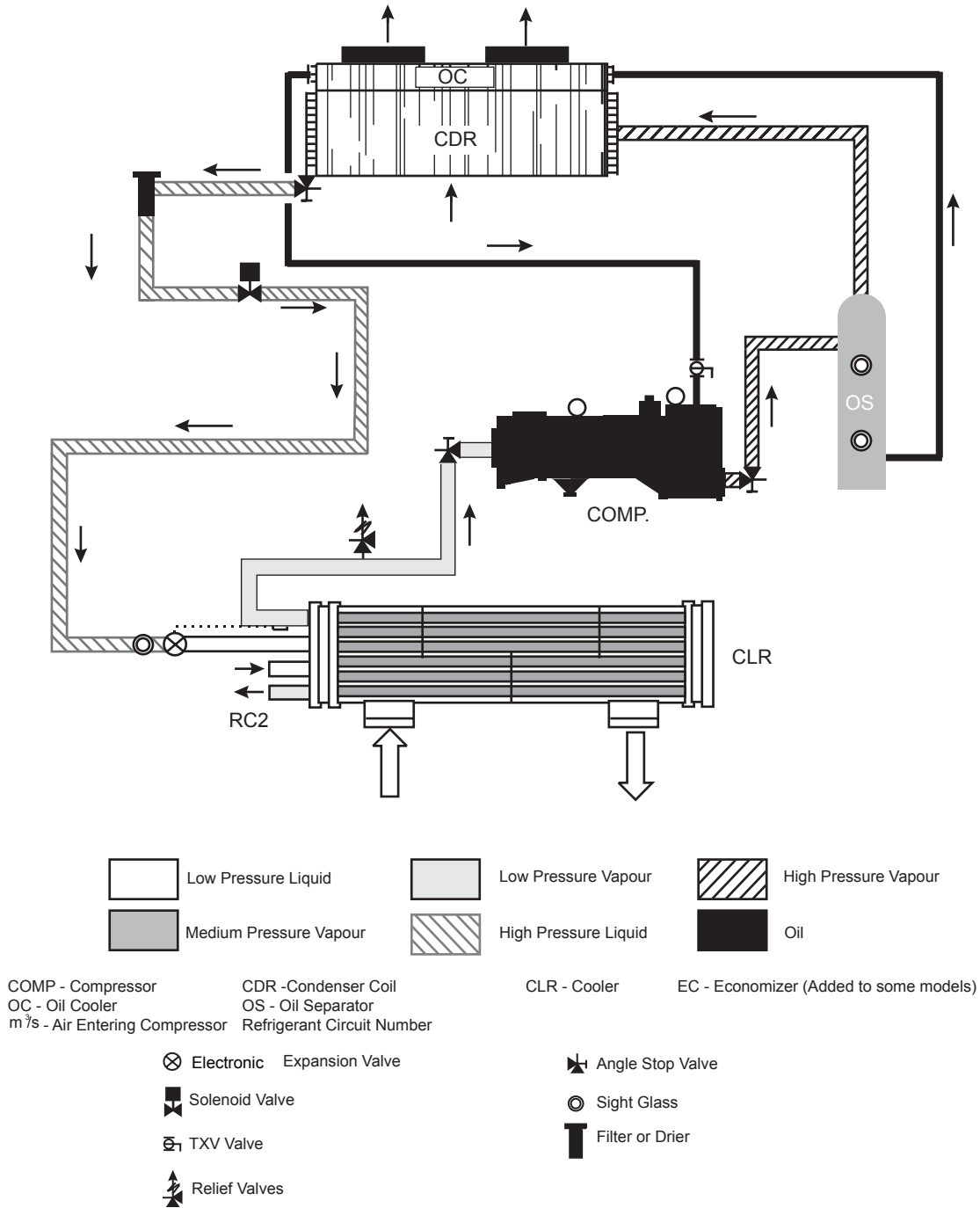

LD09428A

**FIG. 63 – REFRIGERANT FLOW DIAGRAM**

Low pressure liquid refrigerant enters the evaporator and is evaporated and superheated by the heat energy absorbed from the chilled water passing through the evaporator shell. Low pressure vapor enters the compressor where pressure and superheat are increased. High pressure vapor is passed through the oil separator where compressor oil is removed and recirculated to the compressor via the condenser. The high pressure oil-free vapor is fed to the air cooled condenser coil where the heat is removed. On economized models, the fully condensed liquid enters the economizer.

A small percentage of the of the liquid passes through an expansion valve, into the other side of the economizer where it is evaporated. This low pressure liquid subcools the major part of the refrigerant. Medium pressure vapor then returns to the compressor. The subcooled refrigerant then passes through the expansion valve where pressure is reduced and further cooling takes place before returning to the evaporator.

# PROCESS AND INSTRUMENTATION DIAGRAM

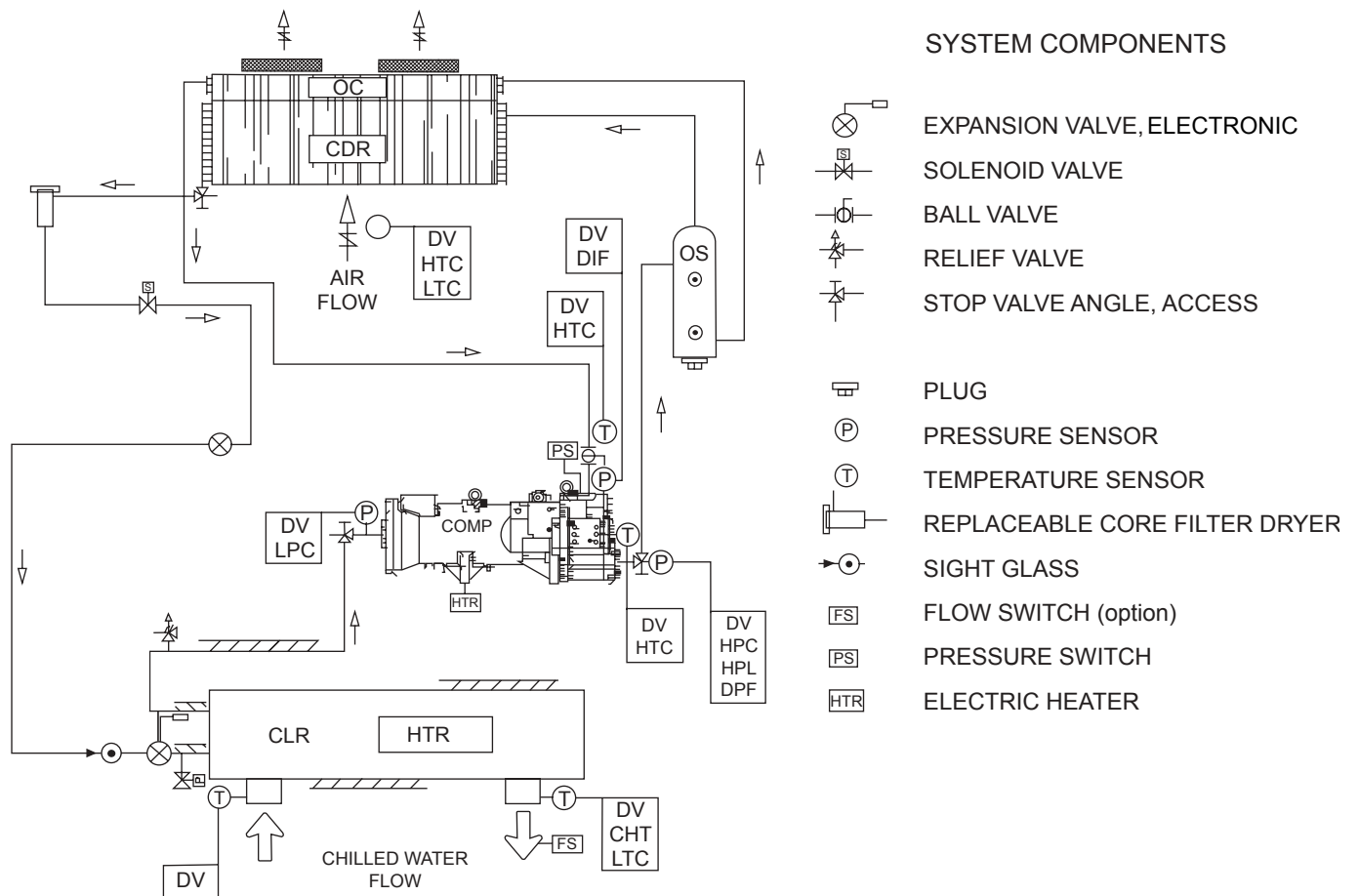

## SYSTEM COMPONENTS

- EXPANSION VALVE, ELECTRONIC
- SOLENOID VALVE
- BALL VALVE
- RELIEF VALVE
- STOP VALVE ANGLE, ACCESS
- PLUG
- PRESSURE SENSOR
- TEMPERATURE SENSOR
- REPLACEABLE CORE FILTER DRYER
- SIGHT GLASS
- FLOW SWITCH (option)
- PRESSURE SWITCH
- ELECTRIC HEATER

## MAJOR COMPONENTS

- COMP COMPRESSOR
- CDR CONDENSER COIL
- CLR COOLER
- OC OIL COOLER COIL
- OS OIL SEPARATOR

## MICROPROCESSOR CONTROL FUNCTIONS

- CHT CHILLED LIQUID THERMOSTAT
- DIF DIFFERENTIAL PRESSURE CUTOUT
- DPF DISCHARGE PRESSURE FAN CONTROL
- DV DISPLAY VALUE
- HPL HIGH PRESSURE LOAD LIMITING
- HTC HIGH TEMPERATURE CUTOUT
- LPC LOW PRESSURE CUTOUT
- LTC LOW TEMPERATURE CUTOUT

FIG. 64 – PROCESS AND INSTRUMENTATION DIAGRAM

### COMPONENT LOCATIONS – 3 COMPRESSOR UNITS

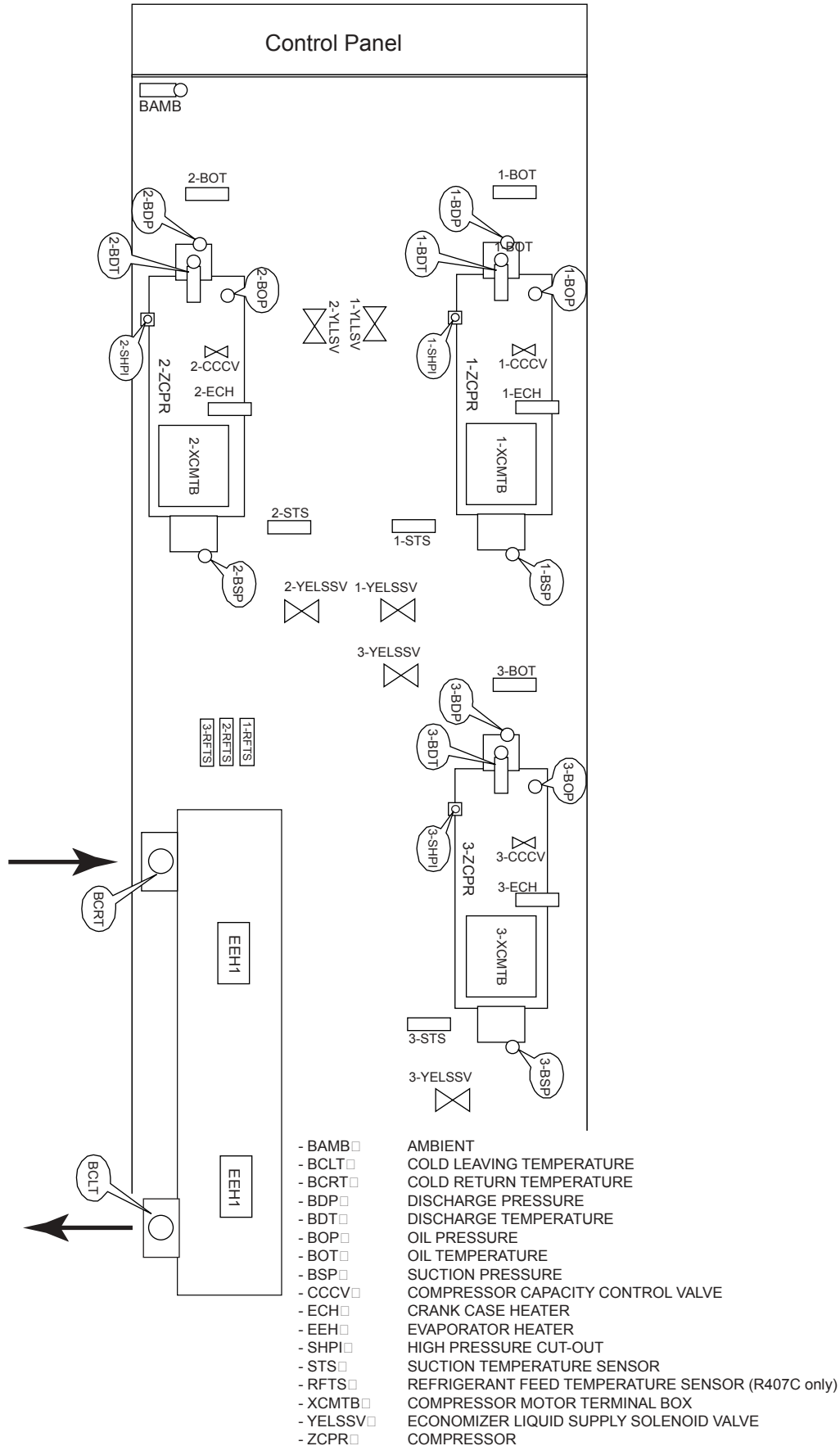

LD05021

FIG. 65 – COMPONENT LOCATIONS

# COMPONENT LOCATIONS – 4 COMPRESSOR UNITS

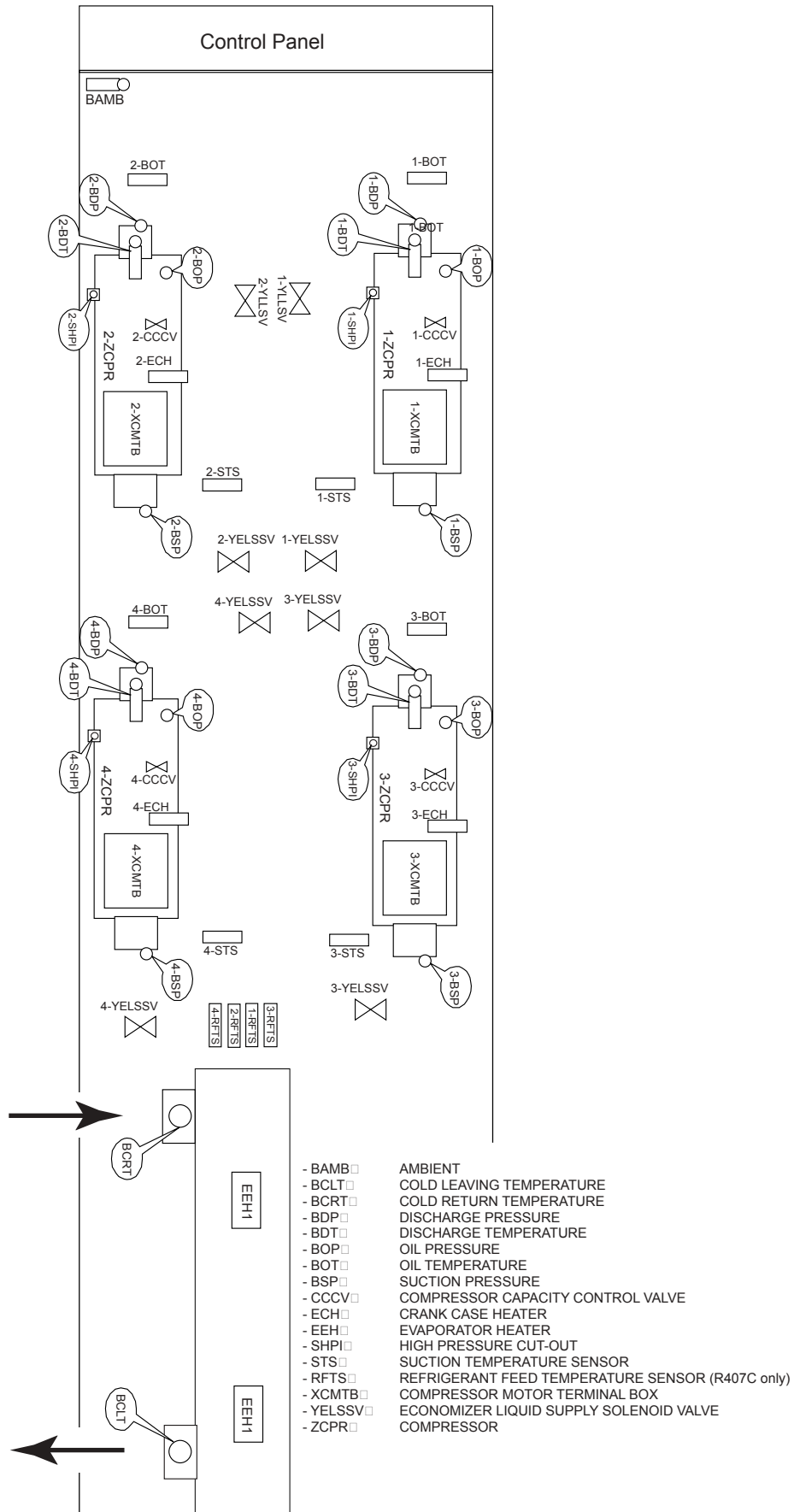

FIG. 65 – COMPONENT LOCATIONS (CONT'D)

# COMPRESSOR COMPONENTS



LD03668

FIG. 66 – COMPRESSOR COMPONENTS

# COMPRESSOR COMPONENTS – CONT'D

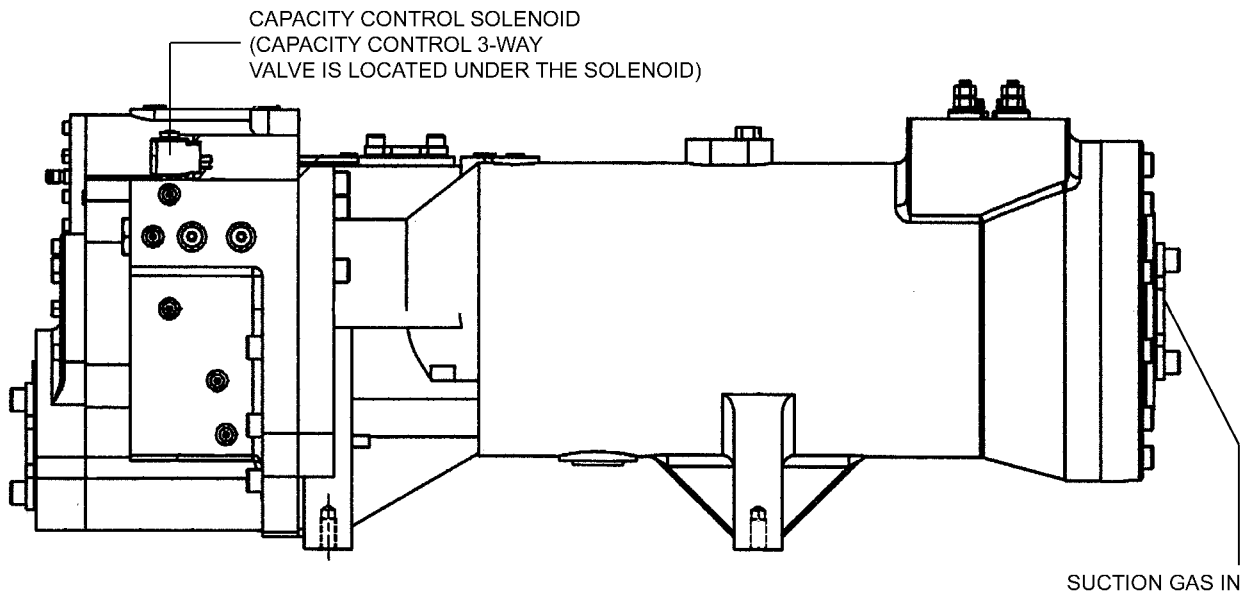

LD03669

FIG. 67 – COMPRESSOR COMPONENTS

### COMPRESSOR COMPONENTS – CONT'D

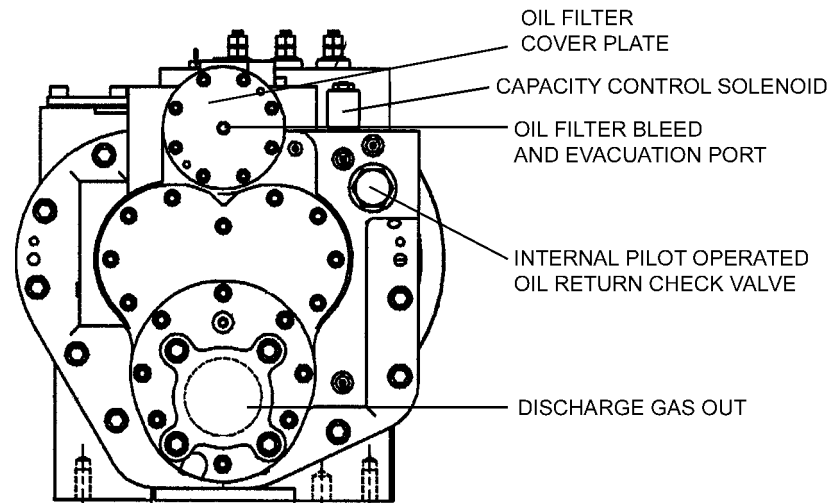

LD03670

FIG. 68 – COMPRESSOR COMPONENTS

# COMPRESSOR COMPONENTS – CONT'D

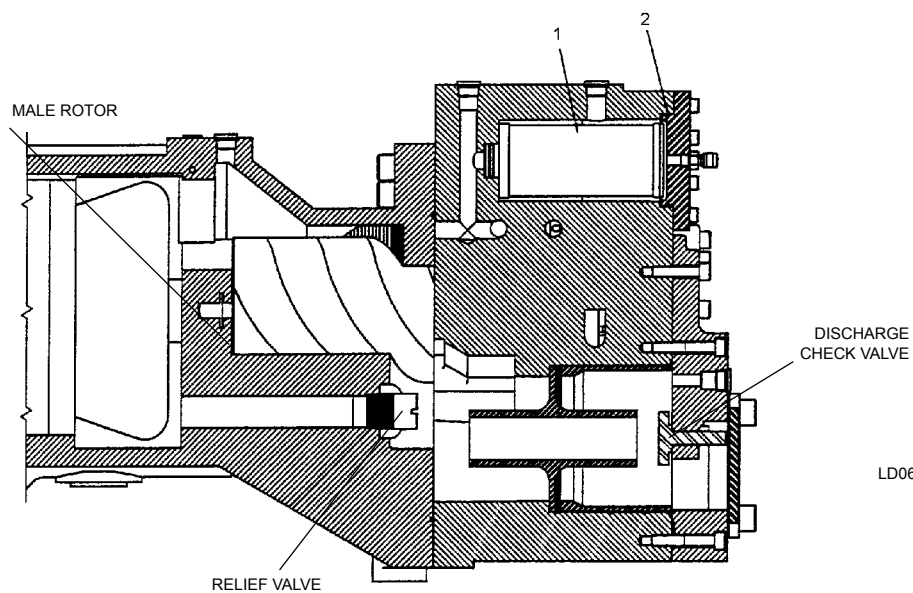

LD06079

FIG. 69 – COMPRESSOR COMPONENTS

### COMPRESSOR COMPONENTS – CONT'D

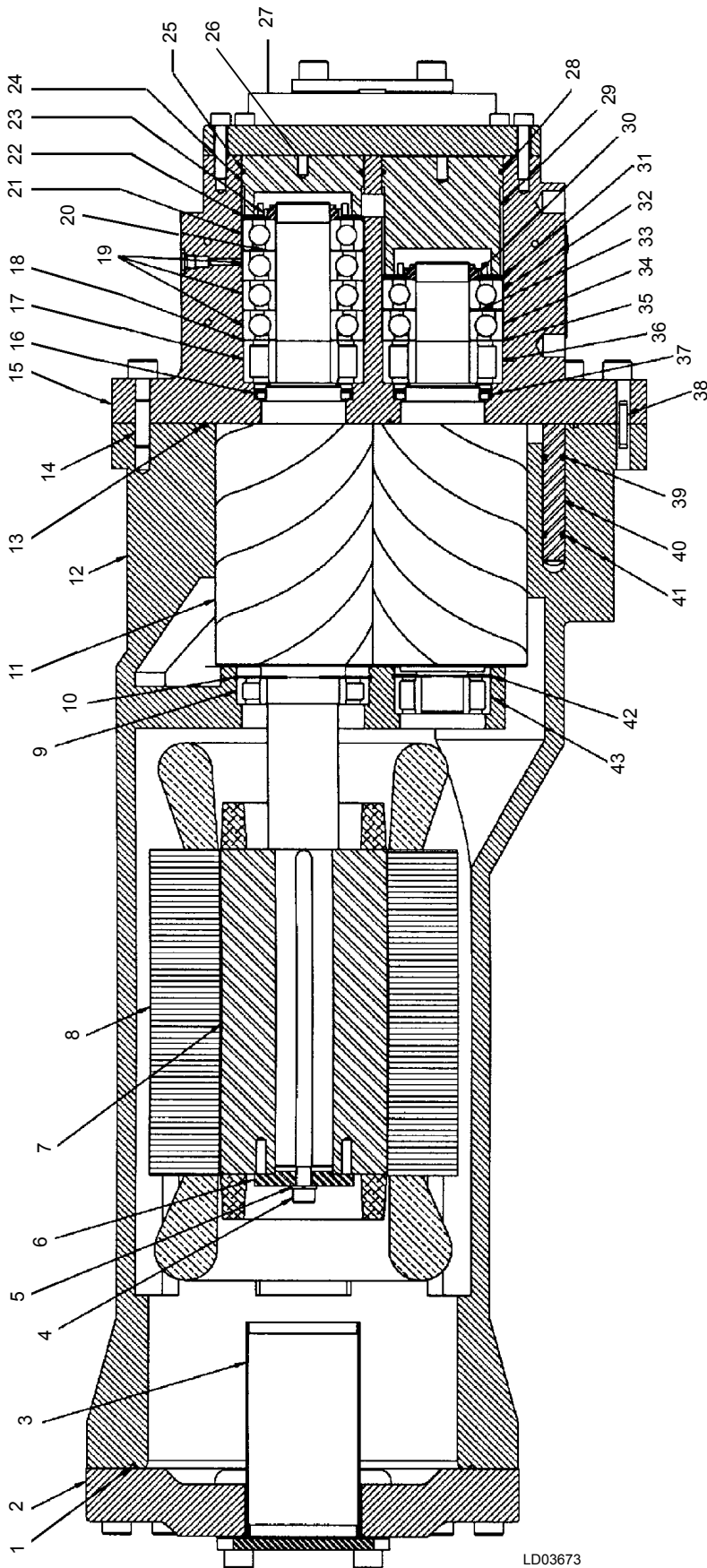

NO.	PART NAME
1	O-RING
2	SUCTION COVER
3	SUCTION STRAINER
4	ROTOR SCREW
5	ROTOR LOCK WASHER
6	ROTOR CLAMP WASHER
7	ROTOR
8	STATOR
9	MALE INLET BEARING
10	MALE ROTOR RETAINING RING
11	MALE ROTOR
12	ROTOR CASE
13	O-RING
14	DOWEL PIN
15	DISCHARGE CASE
16	LIP SEAL
17	DISCHARGE RADIAL BEARING
18	SPACER SHIM
19	THRUST BEARINGS
20	THRUST SPACE SHIM
21	REVERSE THRUST BEARING
22	BEARING CLAMP NUT
23	BEARING SPACER SLEEVE
24	BEARING PRELOAD SPRING
25	O-RING
26	BEARING BORE PLUG
27	DISCHARGE COVER
28	BEARING BORE PLUG
29	BEARING PRELOAD SPRING
30	BEARING SPACER SLEEVE
31	BEARING CLAMP NUT
32	REVERSE THRUST BEARING
33	THRUST SPACER SHIM
34	THRUST BEARINGS
35	SPACER SHIM
36	DISCHARGE RADIAL BEARING
37	LIP SEAL
38	DOWEL PIN
39	SUPPORT RING
40	ECONOMIZER PLUG
41	SUPPORT RING
42	FEMALE ROTOR RETAINING RING
43	FEMALE INLET BEARING

LD03673

FIG. 70 – COMPRESSOR COMPONENTS

## COMPRESSOR COMPONENTS – CONT'D

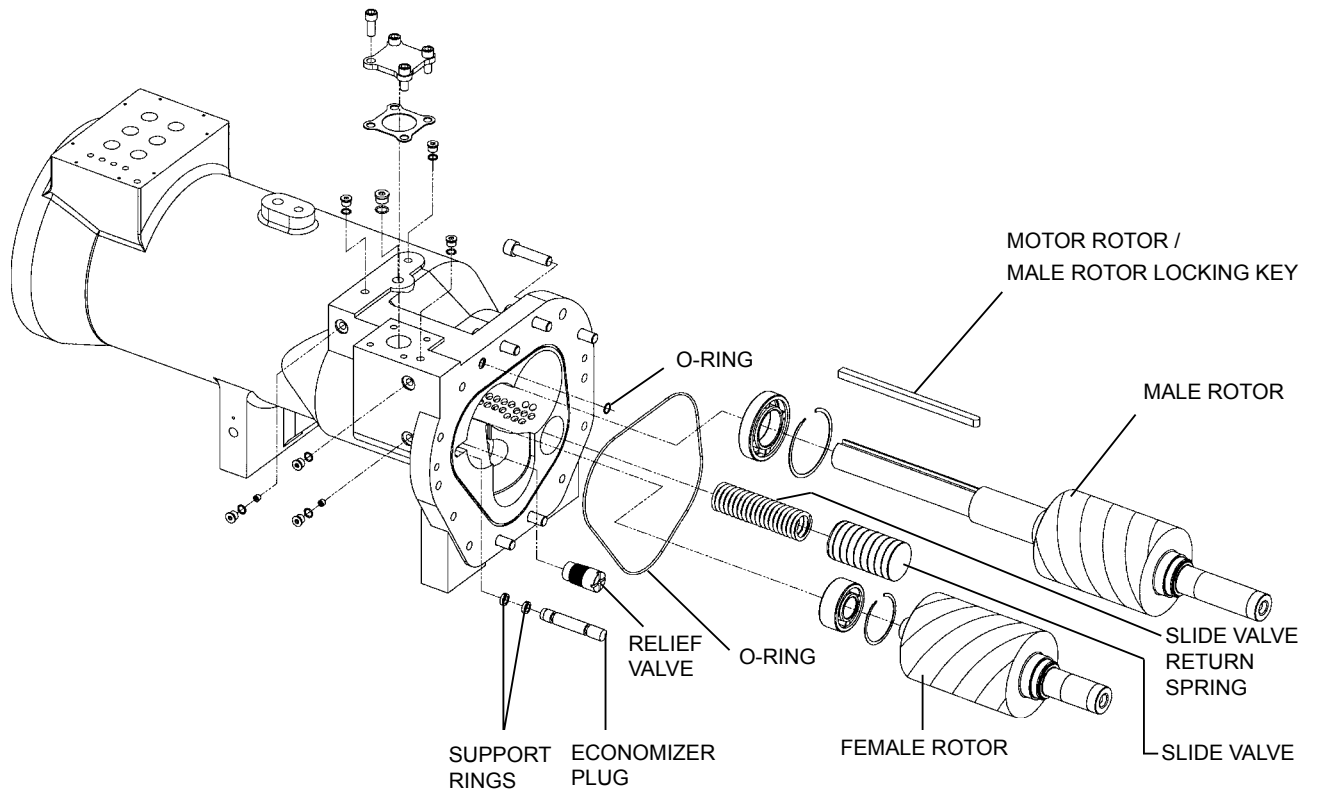

LD03672

FIG. 71 – COMPRESSOR COMPONENTS

## SYSTEM STARTUP CHECKLIST

JOB NAME: _____
SALES ORDER #: _____
LOCATION: _____
SOLD BY: _____
INSTALLING CONTRACTOR: _____
START-UP TECHNICIAN/ COMPANY: _____
START-UP DATE : _____

CHILLER MODEL #: _____
SERIAL #: _____

<b>COMPRESSOR #1</b>
MODEL#: _____
SERIAL #: _____
<b>COMPRESSOR #2</b>
MODEL#: _____
SERIAL #: _____
<b>COMPRESSOR #3</b>
MODEL#: _____
SERIAL #: _____
<b>COMPRESSOR #4</b>
MODEL#: _____
SERIAL #: _____

### UNIT CHECKS (NO POWER)

Check the system 24 hours prior to initial start.

- 1. Inspect the unit for shipping or installation damage.
- 2. Assure that all piping has been completed.
- 3. Check that the unit is properly charged and that there are no piping leaks.
- 4. Open each compressor suction service valve, discharge service valve, economizer service valve, liquid line stop valve, and oil line ball valves.
- 5. The compressor oil level should be maintained so that an oil level is visible in either of the two oil separator sight glasses. In other words, oil level should always be maintained, running or not, above the bottom of the lower sight glass and below the top of the upper sight glass.

If it is necessary to add oil, connect a YORK oil pump to the charging valve on the oil separator, but do not tighten the flare nut on the delivery tubing. With the bottom (suction end) of the pump submerged in oil to avoid entrance of air, operate the pump until oil drips from the flare nut joint, allowing the air to be expelled, and tighten the flare nut. Open the oil charging valve on the oil separator and pump in oil until it reaches the proper level as described above.

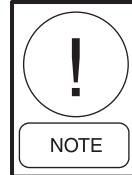

***In actual operation, due to splashing, an oil level may be seen in both sight glasses. Run the compressor for a few minutes fully loaded, shut the system down, and assure there is an oil level showing in the bottom or top sight glass with the compressor off.***

- 6. Assure water pumps are on. Check and adjust water pump flow rate and pressure drop across the evaporator.

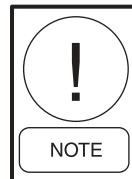

***Excessive flow may cause catastrophic damage to the evaporator.***

- 7. Check the control panel to assure it is free of foreign material (wires, metal chips, etc.).
- 8. Visually inspect wiring (power and control). Wiring MUST meet N.E.C. and local codes. See Fig. 9 and 10, pages 34 and 35.
- 9. Check tightness of power wiring inside the power panel on both sides of the motor contactors and inside the motor terminal boxes.
- 10. Check for proper size fuses in main and control circuits.
- 11. Verify that field wiring matches the 3-phase power requirements of the compressor. See chiller nameplate (Pages 23 - 24).
- 12. Assure 115VAC Control Power has 30A minimum capacity. See Fig. 14, page 39.
- 13. Be certain all water temp sensors are inserted completely in their respective wells and are coated with heat conductive compound.
- 14. Assure that evaporator EEV bulbs are strapped onto the suction lines at 4 or 8 o'clock positions.
- 15. Assure that the 15 ton economizer TXV bulbs are strapped onto the compressor economizer supply lines at 4 or 8 o'clock positions.

- 16. Assure that the Flow Switch is properly installed, wired correctly, and working.
- 17. Assure bolts through compressor feet to bottom frame rails are removed.

**PANEL CHECKS**

**(Power ON – Both System Switches “OFF”)**

- 1. Apply 3-phase power and verify its value (See Fig. 9 and 10 pages 34 and 35).
- 2. Apply 115VAC and verify its value on the terminal block in the lower left of the Power Panel. Make the measurement between terminals 5 and 2 (See Fig. 14, page 39). The voltage should be 115VAC +/- 10%.
- 3. **Assure the heaters on each compressor are on. Allow the compressor heaters to remain on a minimum of 24 hours before start-up. This is important to assure that no refrigerant is in the compressor oil at start-up!**
- 4. Program the dip switches on the microprocessor board for the desired operating requirements. See Fig. 77, Page 159. OPEN = Left side of switch pushed down. CLOSED = Right side of switch pushed down.

SWITCH	SWITCH "OPEN" SETTING	SWITCH "CLOSED" SETTING
1	Water Cooling	Glycol Cooling
2	Standard Ambient Control	Low Ambient Control
3	Refrigerant R-407C	Refrigerant R-22
4	Do Not Use	YCAS
5	Do Not Use	Motor Current Averaging (Start-Up) Disabled
6	Heat Recovery Disabled	Do Not Use
7	Expansion Valve Thermostatic	Expansion Valve Electronic*
8	Spare	Spare

\*Expansion valve electronic should always be selected when an EEV is installed.

Verify the selections by pressing the OPTIONS Key on the control panel. Check them off in the chart above.



***Damage to the chiller could result if switches are improperly programmed.***

- 5. Program the required operating values into the micro for cut-outs, safeties, etc. and record them in the chart below. See Page 178 for details.  
Record programmed values in the chart below.

**PROGRAMMED VALUES**

- Display Language = \_\_\_\_\_
- Discharge Press Cutout = \_\_\_\_\_ PSIG (kPa)
- Discharge Press Unload = \_\_\_\_\_ PSIG (kPa)
- Suction Press Cutout = \_\_\_\_\_ PSIG (kPa)
- High Amb Cutout = \_\_\_\_\_ °F (°C)
- Low Amb Cutout = \_\_\_\_\_ °F (°C)
- Leaving Chilled Liquid Temp Cutout = \_\_\_\_\_ °F (°C)
- High Motor Current Unload = \_\_\_\_\_ % FLA
- Anti-Recycle Time = \_\_\_\_\_ Secs
- Local / Remote Mode = \_\_\_\_\_
- Display Units = \_ \_\_\_\_\_
- Lead / Lag Control = \_\_\_\_\_
- Power Failure Restart = \_\_\_\_\_
- Suction Superheat Setpoint = \_\_\_\_\_ °F (°C)

- 6. Program the Chilled Liquid Setpoint/Range and record:

Setpoint = \_\_\_\_\_ °F (°C)  
Range = +/- \_\_\_\_\_ °F (°C)

Keep in mind that the setpoint temperature displayed by the micro should equal the desired leaving water temperature.

- 7. Assure that the CLK jumper J18 on the Microprocessor Board is in the ON position (Top 2 pins).
- 8. Set the Time and Date.
- 9. Program the Daily Schedule start and stop times.
- 10. Check the Factory Service Mode programming values, (See Section 8.10) assure they are correct, and record the values:

- Refrigerant Type = \_\_\_\_\_ R22 Chiller Type = \_\_\_\_\_
- Unit Type = \_\_\_\_\_
- Heat Recovery = \_\_\_\_\_
- Sys #1 100% FLA = \_\_\_\_\_ Amps
- Sys #2 100% FLA = \_\_\_\_\_ Amps
- Sys #3 100% FLA = \_\_\_\_\_ Amps
- Sys #4 100% FLA = \_\_\_\_\_ Amps

Sys #1 Motor Protector Input = \_\_\_\_\_ Volts  
 Sys #2 Motor Protector Input = \_\_\_\_\_ Volts  
 Sys #3 Motor Protector Input = \_\_\_\_\_ Volts  
 Sys #4 Motor Protector Input = \_\_\_\_\_ Volts



***Typically, these values should not be changed. Incorrect programming may cause catastrophic chiller failure.***

- 11. Check the Motor Protector Dip Switch programming. The switches should correctly set at the factory. The switches may be checked visibly and the total ON switches added using binary addition to determine the setting or by reading the display on the motor protector. See Section 8 for programming information. Record the values below:

Sys #1 Wires thru each hole of the C.T. = \_\_\_\_\_  
 Sys #1 MP Setting = \_\_\_\_\_  
 Sys #2 Wires thru each hole of the C.T. = \_\_\_\_\_  
 Sys #2 MP Setting = \_\_\_\_\_  
 Sys #3 Wires thru each hole of the C.T. = \_\_\_\_\_  
 Sys #3 MP Setting = \_\_\_\_\_  
 Sys #4 Wires thru each hole of the C.T. = \_\_\_\_\_  
 Sys #4 MP Setting = \_\_\_\_\_

**INITIAL START-UP**

After the control panel has been programmed and the compressor heater has been on for 24 hours prior to start-up, the chiller may be placed into operation.

- 1. Place the System Switches on the Microprocessor Board to the ON position.
- 2. The compressor will start and a flow of refrigerant will be noted in the sight glass. After several minutes of operation, the bubbles in the sight glass will disappear and there will be a solid column of liquid when the TXV stabilizes. After the water temperature stabilizes at desired operating conditions, the sight glass should be clear.
- 3. Allow the compressor to run a short time, being ready to stop it immediately if any unusual noise or adverse conditions develop. Immediately at start-up, the compressor will make sounds different from its normal high pitched sound. This is due to the compressor coming up to speed and lubrication changing from liquid refrigerant to

oil. This should be of no concern and lasts for only a short time.

- 4. Check the system operating parameters. Do this by selecting various displays such as pressures and temperatures. Compare these to test gauge readings.

**CHECKING SUBCOOLING AND SUPERHEAT**

The subcooling should always be checked when charging the system with refrigerant and/or before setting the superheat.

When the refrigerant charge is correct, there will be no bubbles in the liquid sight glass with the system operating under full load conditions, and there will be 12 - 15°F (6 - 8°C) subcooled liquid leaving the condenser. An overcharged system should be guarded against. Evidences of overcharge are as follows:

- a. If a system is overcharged, the discharge pressure will be higher than normal. (Normal discharge/condensing pressure can be found in the refrigerant temperature/pressure chart; use entering air temperature +30°F (17°C) for normal condensing temperature.
- b. The temperature of the liquid refrigerant out of the condenser should be not be more than 15°F (8°C) less than the condensing temperature (The temperature corresponding to the condensing pressure from the refrigerant temperature/pressure chart).

The subcooling temperature of each system should be calculated by recording the temperature of the liquid line at the outlet of the condenser and subtracting it from the recorded liquid line pressure at the liquid stop valve, converted to temperature from the temperature/pressure chart.

Example:

Liquid line pressure =  
 202 PSIG converted to 102°F (39°C)  
 minus liquid line temp. - 87°F (31°C)  
 SUBCOOLING = 15°F (8°C)

The subcooling should be adjusted to 12-15°F (6-8°C).

- 1. Record the liquid line pressure and its corresponding temperature, liquid line temperature and subcooling below:

	SYS 1	SYS 2	SYS 3	SYS 4		
Liq Line Press =	_____	_____	_____	_____	PSIG	(kPa)
Temp =	_____	_____	_____	_____	°F	(°C)
Liq Line Temp =	_____	_____	_____	_____	°F	(°C)
Subcooling =	_____	_____	_____	_____	°F	(°C)

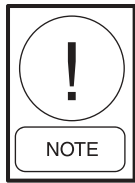

***If equipped with an economizer, the economizer will provide approximately an additional 20°F (11.1°C) subcooling at the expansion valve in ambients above 90°F (32°C). Below 90°F (32°C), the economizer will not provide additional subcooling.***

After the subcooling is set, the suction superheat should be checked. The superheat should be checked only after steady state operation of the chiller has been established, the leaving water temperature has been pulled down to the required leaving water temperature, and the unit is running in a fully loaded condition. Correct superheat setting for a system is 10 - 12°F (6 - 7°C).

The superheat is calculated as the difference between the actual temperature of the returned refrigerant gas in the suction line entering the compressor and the temperature corresponding to the suction pressure as shown in a standard pressure/temperature chart.

Example:

$$\begin{array}{r} \text{Suction Temp} = 46^{\circ}\text{F} \quad (8^{\circ}\text{C}) \\ \text{minus Suction Press} \\ 60 \text{ PSIG converted} \\ \text{to Temp} \quad - 34^{\circ}\text{F} \quad (1^{\circ}\text{C}) \\ \hline 12^{\circ}\text{F} \quad (7^{\circ}\text{C}) \end{array}$$

The suction temperature should be taken 6" (13 mm) before the compressor suction service valve, and the suction pressure is taken at the compressor suction service valve.



***The EEV is non-adjustable. Superheat setpoint is programmable from the keypad.***

- ❑ 2. Record the suction temperature, suction pressure, suction pressure converted to temperature, and superheat of each system below:

	SYS 1	SYS 2	SYS 3	SYS 4		
Suction Temp =	_____	_____	_____	_____	PSIG	(kPa)
Suction Press =	_____	_____	_____	_____	°F	(°C)
Temp =	_____	_____	_____	_____	°F	(°C)
Superheat =	_____	_____	_____	_____	°F	(°C)

**CHECKING ECONOMIZER SUPERHEAT (IF APPLICABLE) (15 TON TXV)**

The economizer superheat should be checked to assure

proper economizer operation and motor cooling. Correct superheat setting is approx. 10 - 12°F (6 - 7°C).

The superheat is calculated as the difference between the pressure at the Economizer Service Valve on the compressor converted to the corresponding temperature in a standard pressure/temperature chart and temperature of the gas at the bulb on the entering piping to the motor housing.

Example:

$$\begin{array}{r} \text{Economizer Gas Temp} = 90^{\circ}\text{F} \quad (32^{\circ}\text{C}) \\ \text{minus Economizer Press} \\ 139 \text{ PSIG converted} \\ \text{to Temp} \quad - 78^{\circ}\text{F} \quad (26^{\circ}\text{C}) \\ \hline 12^{\circ}\text{F} \quad (6^{\circ}\text{C}) \end{array}$$

Normally, the thermal expansion valve need not be adjusted in the field. If however, adjustment needs to be made, the expansion valve adjusting screw should be turned not more than one turn at a time, allowing sufficient time (approximately 15 minutes) between adjustments for the system and the thermal expansion valve to respond and settle out. Assure that superheat is set between 10 - 12°F (6 - 7°C).

- ❑ 1. Record the motor gas temperature, economizer pressure, economizer pressure converted to temperature, and economizer superheat below:

	SYS 1	SYS 2	SYS 3	SYS 4		
Economizer Gas Temp =	_____	_____	_____	_____	PSIG	(kPa)
Economizer Press =	_____	_____	_____	_____	°F	(°C)
Temp =	_____	_____	_____	_____	°F	(°C)
Superheat =	_____	_____	_____	_____	°F	(°C)



***This superheat should only be checked in an ambient above 90°F (32°C). Otherwise, mid-range adjustment (factory setting) is acceptable. Below 90°F (32°C) ambient, the economizer will not provide additional subcooling.***

**LEAK CHECKING**

- ❑ 1. Leak check compressors, fittings, and piping to assure no leaks.

If the unit is functioning satisfactorily during the initial operating period, no safeties trip and the compressors load and unload to control water temperature, the chiller is ready to be placed into operation.

## SECTION 8 - MICRO PANEL CONTENTS CHILLER CONTROL PANEL PROGRAMMING AND DATA ACCESS KEYS



### DISPLAY AND STATUS INFORMATION KEYS

#### Status Key - see Section 2

This key provides a display of the current operational and/or fault status of the chiller or individual refrigerant systems.

#### Display Keys - see Section 3

Each key provides a real time display of commonly required information about the chiller and individual system operating conditions and settings.

#### Print Keys - see Section 4

These keys allow control panel display or remote printout of both current real-time operating and programmed data as well as fault history data from recent safety shutdowns.

### ON / OFF ROCKER SWITCH

This switch shuts down the entire chiller when placed in the OFF position. The switch must be ON for the chiller to operate. The systems will not pump down at shutdown when the UNIT switch is switched OFF.

### PROGRAM & SETUP KEYS

#### Entry Keys - see Section 5

The numeric and associated keys are used for entering data required for programming the chiller. The ENTER and  $\uparrow\downarrow$  keys are also used for scrolling through information available after pressing certain keys.

#### Setpoints Keys - see Section 6

These keys are used for display and programming of the local and remote offset chilled liquid temperature setpoints.

#### Clock Keys - see Section 7

These keys are used for display and programming of the clock and operating schedule for the chiller.

#### Program Key - see Section 8

This key is used for display and programming of the chiller operational settings and limits.

## 1. INTRODUCTION & PHYSICAL DESCRIPTION



29023A

### 1.1 GENERAL

The YORK Screw Chiller Control Panel is a microprocessor based control system fitted to YCAS liquid chillers. It is capable of multi-refrigerant system control to maintain chilled liquid temperature within programmed limits and to provide safety control of the chiller. The microprocessor monitors leaving chilled liquid temperature deviation from setpoint and the rate of change of this temperature to start, stop, load and unload compressors as required.

User interface is via a touch keypad and a liquid crystal display allowing access to operating and programmed data. Information can be displayed in English (Imperial) units or SI (Metric) units (Section 8.1). Conversion tables are provided at the back of this manual.

A master ON/OFF rocker switch is provided on the chiller control panel to activate or deactivate the complete chiller, while switches to activate or deactivate individual refrigerant systems are provided on the Microprocessor Board.

External interface is available for control of the chiller via a YORK ISN System or YORK Remote Control Center. In addition, EMS/BAS System connections are

provided for remote cycling, current limiting, remote temperature setpoint reset and alarm annunciation.

YCAS chillers each have a single split circuit evaporator serving 3 or 4 independent refrigerant systems. YCAS 2, 3, & 4 system chillers are configured as a single self contained section with a single control panel controlling the two, three, or four refrigerant systems.

### 1.2 KEYPAD & DISPLAY

An operator keypad allows complete control of the chiller from a central location. The keypad offers a multitude of commands available to access displays, program setpoints, and initiate system commands. Keys are grouped and color coded for clarity and ease of use.

A 40 Character Liquid Crystal Display (2 lines of 20 characters) is used for displaying system parameters and operator messages. The display has a lighted background for night viewing as well as a special feature which intensifies the display for viewing in direct sunlight.

Displays will be updated every two seconds by the microprocessor.

### 1.3 UNIT (CHILLER) ON / OFF SWITCH

A master UNIT (Chiller) ON / OFF switch is located just below the keypad. This switch allows the operator to turn the entire chiller OFF, if desired. The switch must be placed in the ON position for the chiller to operate. Any time the switch is in the OFF position, a Status message indication will be displayed. See page 134 for the location of this switch.

### 1.4 MICROPROCESSOR BOARD

The Microprocessor Board controls and makes decisions for the chiller. Information inputs from transducers and sensors around the chiller are either connected directly to the Microprocessor Board or are connected to the I/O Expansion Board and multiplexed before being sent to the Microprocessor Board.

The Microprocessor Board circuitry multiplexes all of these analog inputs, digitizes them, and constantly scans them to monitor chiller operating conditions. Based on this information, the Microprocessor issues commands to the Relay Boards to activate and deactivate contactors, solenoids, etc. for chilled liquid, operating control, and safety control.

Commands are sent from the Microprocessor Board to the I/O Expansion Board to control the slide valves for chilled liquid control.

Keypad commands are acted upon by the micro to change setpoints, cutouts, scheduling, operating requirements, and to provide displays.

A +12VDC REG supply voltage from the Power Supply Board is converted to +5V REG by a voltage regulator located on the Microprocessor Board. This voltage is used to operate the integrated circuitry on the board.

#### System Switches 1 - 4

System Switches for each system are located on the Microprocessor Board ). These switches allow the operator to selectively turn a given system on or off as desired.

#### Internal Clock & Memory Backup Battery

The Microprocessor Board contains a Real Time Clock integrated circuit chip (Section 1.11, Item 2) with an internal battery backup. The battery backup assures that any programmed values (setpoints, clock, cutouts, etc.) are not lost during a power failure or shutdown period regardless of the time involved.

The battery is a 10 year lithium type, but life will depend upon whether the Real Time Clock's internal clock circuit is energized. With the clock OFF, a rated life of approximately 10 years can be expected. With the clock ON, approximately 5 years. The clock is enabled and disabled using a jumper on the microprocessor board.

If the chiller is shut down or power failure is expected for extended periods, it may be desirable to disable the clock to save battery life. The clock can then be reactivated and reprogrammed when the chiller is returned to service. This will not affect the maintenance of programmed values and stored data by the backup battery.

While a chiller is operating, the clock must be ON (Section 1.11, Item 1) or the internal clock on the microprocessor will not be active and the micro cannot keep track of time, although all other functions will operate normally. Failure to turn the Clock ON could result in the chiller not starting due to the time "frozen" on the clock falling outside the Start/Stop time programmed in the Daily Schedule, see Section 7.3.

### 1.5 ANCILLARY CIRCUIT BOARDS

#### Power Supply Board

The on-board switching power supply is fuse protected and converts 24VAC from the logic transformer 2T to +12V REG which is supplied to the Microprocessor Board, Relay Output Boards, and the 40 character display to operate the integrated circuitry.

24VAC is filtered, but not regulated, to provide unregulated +24VDC to supply the flow switch, PWM remote temperature reset, PWM remote current reset, lead / lag select, and remote print circuitry which may be utilized with user supplied contacts.

24VAC is also filtered and regulated to +24VDC to be used by the optional EMS/BAS Circuit Boards for remote temperature or remote current reset.

Individual rectifier and filtering circuits are present which receive the Current Transformer signals for each phase of motor current on each compressor. These circuits rectify and filter the signals to variable DC. A phase rotation circuit for each compressor is also present to assure that the screw compressors do not run in the wrong direction. All of these signals are sent to the I/O Expansion Board which multiplexes them and then feeds them to the Microprocessor Board.

### I/O Expansion Board #1

The I/O Expansion Board provides multiplexing to allow additional inputs to be connected to the Microprocessor Board via a single data line. The additional inputs are multiplexed according to the selection made by the Microprocessor through address lines.

Signals routed through the I/O Expansion Board include Discharge Temperature, Motor Protector, Current Transformer outputs (motor current signals from the 2ACE module), and Oil Temperature.

Included on the I/O Expansion Board are the outputs for the slide valve control. This control consists of a Digital to Analog Converter (DAC) and power transistors to modulate current through the slide valve solenoids.

### I/O Expansion Board # 2

The second I/O Expansion Board is used only on 3 and 4 compressor YCAS chillers. Due to limited output and input capabilities of the main Microprocessor Board, an additional Microprocessor is needed to control a third and fourth compressor.

The second I/O Expansion Board has processing capabilities. It's job is to monitor inputs from the third and fourth compressor, provide safety control, and shuttle information back to the main Microprocessor Board. The shuttling of information is done using an RS-485 communication line to the Microprocessor Board.

Communication between the Microprocessor Board and I/O Board #2 takes place approximately once every second. The communications transfer is necessary to enable the main Microprocessor to display system parameters and command the starting, stopping, loading, and unloading of System 3 and 4 to control chilled liquid temperature.

The second I/O Expansion Board also controls the outputs to a Relay Output Board which activates and de-activates 115VAC control outputs to System 3 and 4 compressors, solenoids, etc. These outputs are controlled in response to commands issued by the Microprocessor Board.

### Relay Output Boards

One Relay Output Board per system operates the motor contactors/starters, solenoid valves, and heaters which control system operation.

The relay boards are located in the logic section of the control panel(s). The boards convert 0 - 12VDC logic levels outputs from the Microprocessor Board to 115VAC levels used by the contactors, valves, etc.

The common side of all relays on the Relay Output Board is connected to +12VDC REG. The open collector outputs of the Microprocessor Board energize the DC relays or triacs by pulling the other side of the relay coil/triac to 0VDC. When not energized, both sides of the relay coils or triacs will be at +12VDC potential.

## 1.6 CIRCUIT BREAKERS

Circuit Breakers are provided for the 115VAC controls.

- CB1, CB2, and CB3 allows removal of control power from respective System 1, 2, or 3 for control system circuitry servicing. Specifically, the 115VAC feed to Relay Output Board 1 which energizes contactors and solenoids.
- CB4 allows removal of control power to the Microprocessor Board, Power Supply Board, I/O Expansion Boards, and Evaporator Heater on 3 System chillers.
- CB5 allows removal of control power to the Microprocessor Board, Power Supply Board, I/O Expansion Board, and Evaporator Heater on 4 System chillers.



***The Circuit Breakers remove 115VAC control power only. High voltage circuitry will still be energized from the high voltage supply.***



***REMOVING 115VAC power to or opening CB4 (3 System chillers) or CB5 (4 System chillers), removes power from the evaporator heaters. This could cause evaporator freeze-up in low ambient temperatures. Removing 115VAC power to individual circuits also removes power to the compressor heaters, which should also be avoided.***

## 1.8 TRANSFORMERS

3 Transformers (2T, 3T, and 4T) are located in the Control Panel. These transformers convert the 115VAC Control Power Input to 24VAC to operate the microprocessor circuitry.

1T: Supplies 24V to I/O Expansion Board # 2

2T: This 75VA transformer supplies 24VAC to the microprocessor power supply board.

3T: Supplies the I/O Expansion Board # 1 voltage for slide valve control.

4T: Supplies 24VAC power to the 2ACE Motor Protector Modules.

## 1.9 MOTOR PROTECTOR MODULES

A Motor Protector Module for each compressor is located in the Control Panel. These modules supply motor over-temperature protection, 3-phase current protection, phase imbalance, phase rotation, and a programming and troubleshooting 7 segment display.

The motor over-temperature protection is supplied by 3 temperature sensors imbedded in the motor windings 120 degrees apart. The module monitors these sensors allowing it to sense a hot winding and shut down the compressor if motor cooling is inadequate.

The on-board C.T.s provide 3 phase current protection which look at 3 of the 6 motor legs and send an analog signal proportional to average motor current to I/O Expansion board and on to the microprocessor board for microprocessor low/high current protection and current display. This allows the micro to monitor current and shut a system down if low or high motor current is sensed. This is a non-adjustable protection circuit electronically sized to a system's motor specifications.

Internally, the (3) on-board 3C.T.s and internal circuitry allow the Motor Protector Module to protect against high motor current as programmed on the Motor Protector dip switches. These switches are set at the factory according to motor specifications.

The module also provides phase rotation protection to assure the screw compressor does not rotate backwards

A single phase protection circuit located in the module monitors for a phase imbalance. If current imbalance exceeds 17% of the average motor current in one of the phases, the Motor Protector will recognize it and shut the system down.

Whenever the Motor Protector Module senses a fault, internal contacts M1 - M2 will open and shut the system down. These contacts are wired in series with the compressor motor contactor. When the contacts open, the micro will attempt to start the system 2 more times. Since the motor contactor signal path from the Relay Output Board to the motor contactor is broken by the Motor Protector Module contacts, it will lock the system out after 3 faults. The Motor Protector Module must then be reset by removing 115VAC power from the Control Panel. After the Motor Protector is reset, the individual system SYS switch (S2-S5) must be switched OFF and then ON to reset the microprocessor to allow restart of the system.

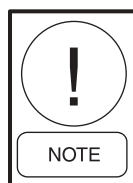

***Anytime the module faults, a thorough investigation of the problem should be performed before attempting to return the system to operation. Failure to perform this investigation could lead to motor or compressor failure. Additional details on the Motor Protector Module can be found on page 16.***

***Always review the data in the HISTORY BUFFER when faults occur. Since the micro attempts to restart 2 more times after the first fault, which opens the M1 and M2 contacts, the last 2 faults will show Low CURR/MP/HP, but will have no value for troubleshooting. The information contained in HISTORY BUFFER #3 will be useful on troubleshooting the cause of the Motor Protector fault.***

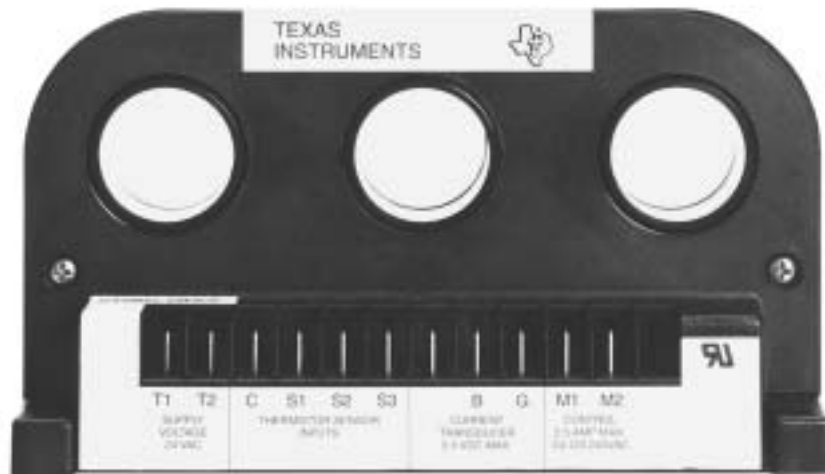

SIDE VIEW

29119A

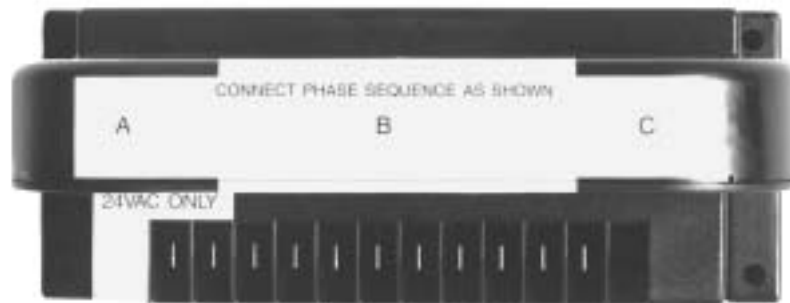

TOP VIEW

29121A

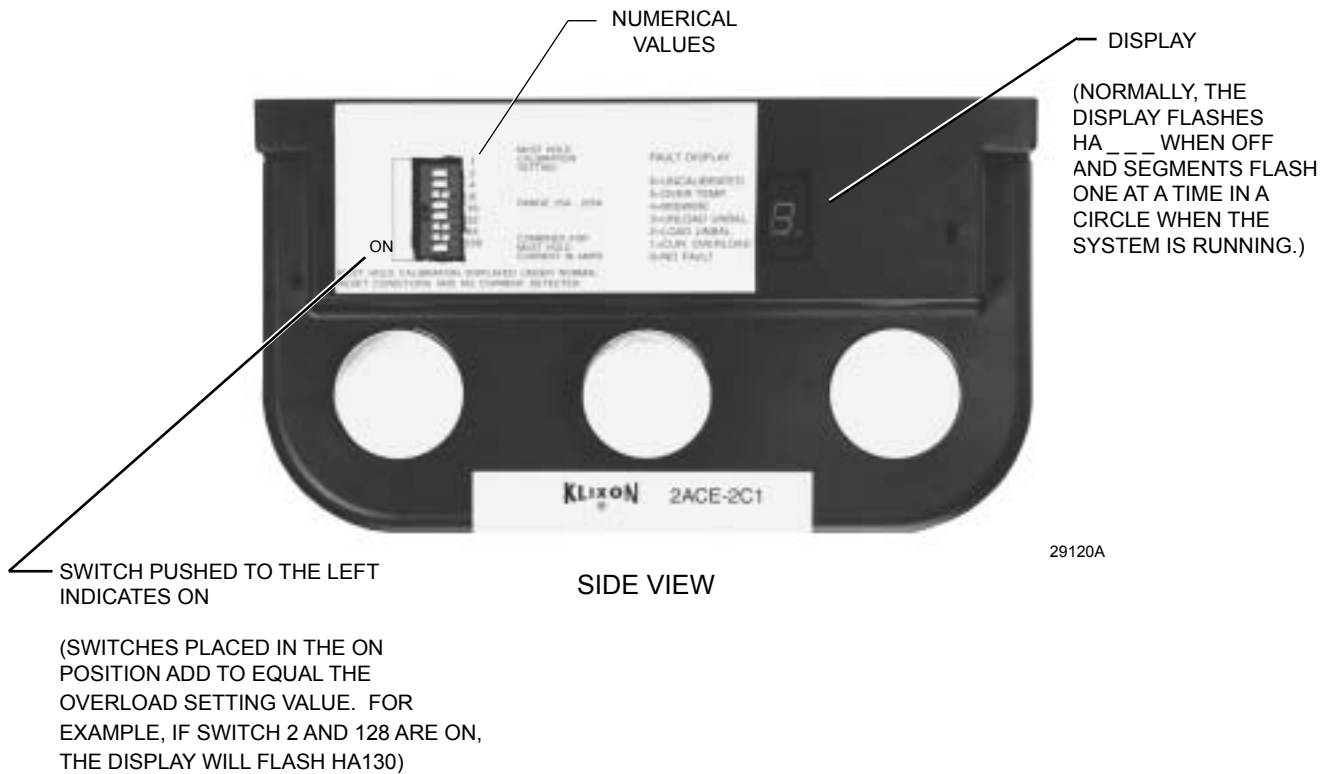

SIDE VIEW

29120A

FIG. 72 – MOTOR PROTECTION MODULE

**1.10 EMS/BAS CONTROLS**

The microprocessor system can accept remote signals to Start/Stop the chiller, adjust maximum allowable running current for each compressor, and adjust the chilled liquid leaving temperature setpoint. These functions can easily be controlled by connecting user supplied “dry” contacts to terminals in the control panel.

**Remote Start/Stop**

Remote Start/Stop can be accomplished using a time clock, manual contact or other “dry” contact in series with the flow switch which is connected to Terminals 13 and 14 in the logic section of the control panel. The contact must be closed to allow the chiller to run. Any time this contact opens, the chiller will shut down and the NO RUN PERM message will be displayed. The location of the flow switch connection is shown in Section 1.12.



***Never bypass a flow switch. This will cause damage to the chiller and void any warranties.***

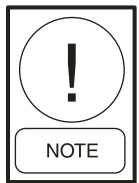

***Wiring from remote “dry” contacts (for stop/start and reset functions) should not exceed 25 ft. (8 m) and should be run in grounded conduit that does not carry any wiring other than control wiring or shielded cable. If an inductive device (relay, contactor) is supplying these contacts, the coil of the device must be suppressed with a suppressor YORK Part Number 031-00808-000 across the inductive coil.***

**Remote Current Reset**

The maximum allowable running current for each compressor can be adjusted remotely to a lower value using repeated timed closure of “dry” contacts connected to Terminals 13 and 16 located in the logic section of the control panel (See Section 1.12). The duration of the contact closure will determine the amount of adjustment. Generally, this input is used for purposes of demand limit and operates as follows:

Closing the input contact for a defined period of time allows reset of the % Current Limit downward. Contact

closure of 1 - 11 seconds will allow % Current Limiting to be adjusted downward from 105% by a maximum of 75%, i.e. to a minimum value of 30% FLA. EMS Current Limiting operates independently of the High Average Current Unload (See Section 8.2). The micro will always look at the two Current Limit Setpoints and choose the lower as the controlling value, whenever Remote Current Limiting is utilized. Contact closures of less than 1 second will be ignored. A closure of 11 seconds is the maximum allowable closure and provides a Current Limit reduction of 75%. The remote reset current can be calculated as follows:

REMOTE

$$\text{RESET} = 105\% \text{ FLA} - \frac{\{(\text{Contact Closed Time} - 1\text{sec}) \times (75\% \text{ FLA})\}}{10 \text{ sec}}$$

For example, after a 4 second pulse, the offset would equal:

$$\begin{aligned} \text{Remote Reset Curr} &= 105\% \text{ FLA} - \frac{\{(4\text{sec} - 1 \text{ sec}) \times (75\% \text{FLA})\}}{10 \text{ sec}} \\ &= 105\% - \frac{225\% \text{FLA sec}}{10 \text{ sec}} \\ &= 82.5\% \text{ FLA} \end{aligned}$$

To maintain a given offset, the contact closure signal must be repeated (refreshed) every 30 seconds - 30 minutes. The refresh is not accerted sooner than 30 seconds from the end of the last PWM signal, but must be refreshed before 30 minutes has elapsed. After 30 minutes, if no refresh is provided, the setpoint will change back to its original value.



***After an offset signal, the new Remote Current Limit may be viewed on the EMS Current Limiting Display under the Motor Current Key (see Section 3.5). However, if this display is being viewed when the reset pulse occurs, the setpoint will not change on the display. To view the new offset, first press any other display key on the keypad and then press the Motor Current Key.***

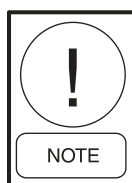

***Remote EMS Reset will not operate when a Remote Control Center Option Kit is connected to the micro. The Remote Control Center will always determine the setpoint.***



**Wiring from remote “dry” contact (for reset functions) should not exceed 25 ft. (8 m) and should be run in grounded conduit that does not carry any wiring other than control wiring or shielded cable. If an inductive device (relay, contactor) is supplying these contacts, the coil of the device must be suppressed with a suppressor YORK Part Number 031-00808-000 across the inductive coil.**



**Remote Current Reset must never be used to control temperature. These contacts are to be used only for periodic demand limiting purposes.**

### Remote Setpoint Temperature Reset

The chilled liquid leaving temperature setpoint programmed into the micro can be remotely adjusted to a higher value using repeated timed closure of “dry” contacts connected to Terminals 13 and 17 of TB4 located in the logic section of the control panel (See Section 8.1.12). The duration of the contact closure will determine the amount of adjustment. This is achieved as follows:

The maximum allowable reset value can be programmed from 2°F - 40°F (1°C - 22°C), as appropriate to the application - see Section 6.4. Once the maximum reset is programmed, an input contact closure of 11 seconds provides the maximum reset. Closure for less than 11 seconds will provide a smaller reset. For noise immunity, the micro will ignore closures of less than 1 second. To compute the necessary contact closure time to provide a required Reset, use the following steps:

$$\text{Reset Temp Offset} = \frac{(\text{Contact Closure} - 1 \text{ sec}) \times \text{Programmed Max Reset}}{10 \text{ sec}}$$

For example, with a programmed setpoint of 44°F (7°C), after a 4 second pulse and a programmed maximum offset of 40°F (22°C), the temperature offset would equal:

$$\text{Reset Temp} = \frac{(4 \text{ sec} - 1 \text{ sec}) \times 40^\circ\text{F}}{10 \text{ sec}}$$

$$\begin{aligned} \text{Reset Temp} &= \frac{120^\circ\text{Fsec}}{10 \text{ sec}} \\ &= 12^\circ\text{F} (6^\circ\text{C}) \end{aligned}$$

**To determine the new setpoint**, add the reset to the setpoint programmed into memory. In the example above, if the programmed setpoint = 44°F (7°C), **the**

**new setpoint after the 4 second contact closure would be 44°F (7°C) + 12°F (6°C) = 56°F (13°C).** This new setpoint can be viewed on the display by pressing the Remote Reset Temperature/Range key.

To maintain a given offset, the contact closure signal must be repeated (refreshed) every 30 seconds - 30 minutes. The refresh is not accepted sooner than 30 seconds from the end of the last PWM signal, but must be refreshed before 30 minutes has elapsed. After 30 minutes, if no refresh is provided, the setpoint will change back to its original value.

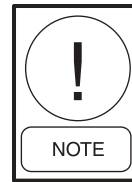

**After an offset signal, the new Remote Setpoint may be viewed by pressing the Remote Cooling Setpoint Key. However, if this display is being viewed when the reset pulse occurs, the setpoint will not change on the display. To view the new offset, first press any other display key on the keypad and then press the Remote Cooling Setpoint key. The new setpoint will then appear.**

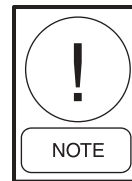

**Remote Setpoint Reset will not operate when a Remote Control Center Option Kit is connected to the Micro. The Remote Control Center will always determine the setpoint.**



**Wiring from remote “dry” contact (for reset functions) should not exceed 25 ft. (8 m) and should be run in grounded conduit that does not carry any wiring other than control wiring or shielded cable. If an inductive device (relay, contactor) is supplying these contacts, the coil of the device must be suppressed with a suppressor YORK Part Number 031-00808-000 across the inductive coil.**



**Remote Setpoint Reset must never be used to control temperature. These contacts are to be used only for occasional temperature setback due to outside ambient, changes in building occupancy, or ice storage.**

1.11 MICROPROCESSOR BOARD LAYOUT

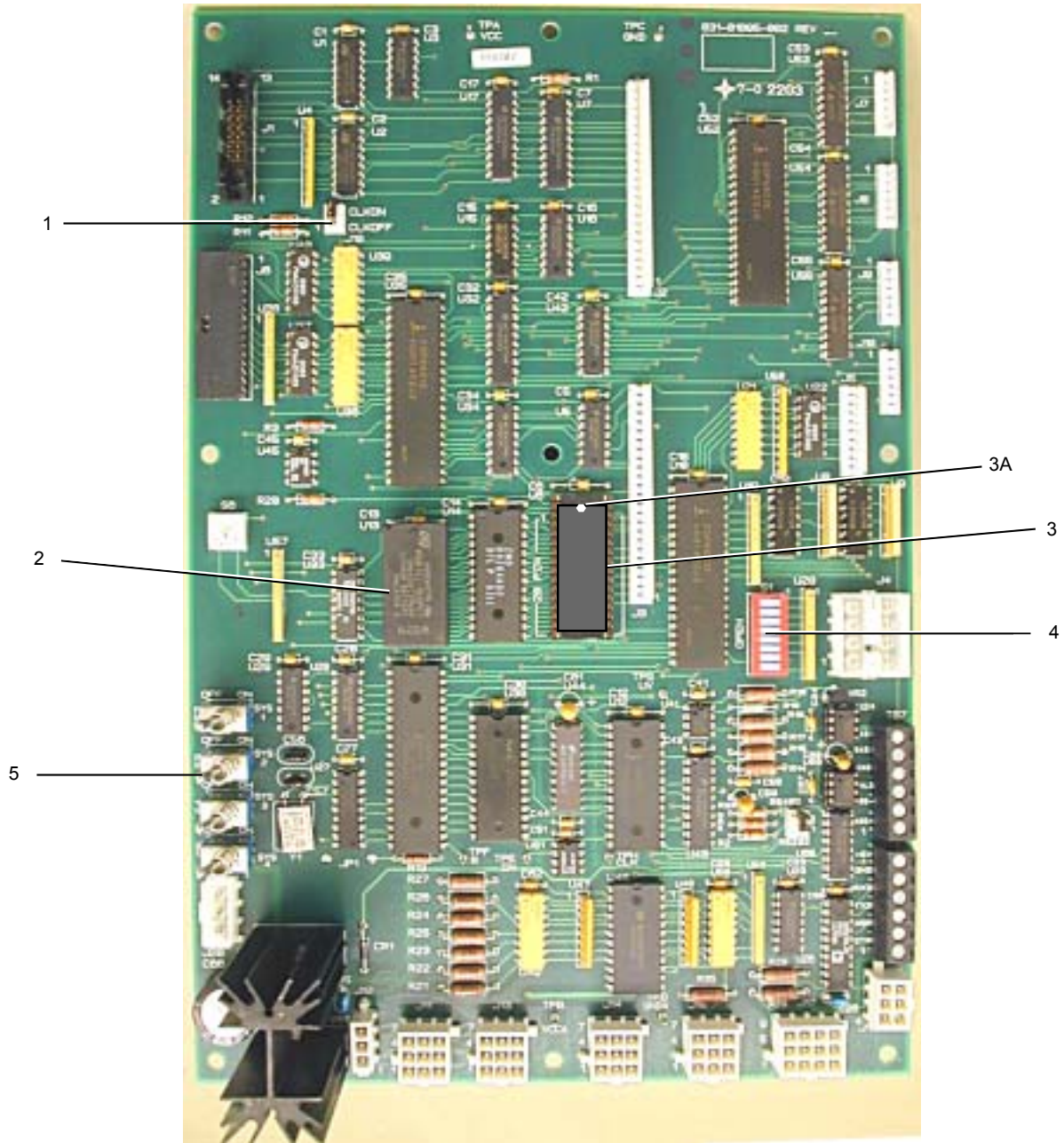

028979-G

ITEM	DESIGNATION	DESCRIPTION
1	J18	Clock Enable/Disable Jump Contact
2	RTC (U13)	Real Time Clock and Battery Backup I.C.
3	EPROM	Microprocessor I.C. (label shows version) <i>NOTE : Dimple is positioned at top edge (3A)</i>
4	S1	Dip Switch Set (8 switches)
5	S2 to S5	System Switches S2 = System 1 S3 = System 2 S4 = System 3 S5 = System 4

FIG. 73 – COMPONENT LAYOUT

1.12 LOGIC SECTION LAYOUT

50 Hz Models :

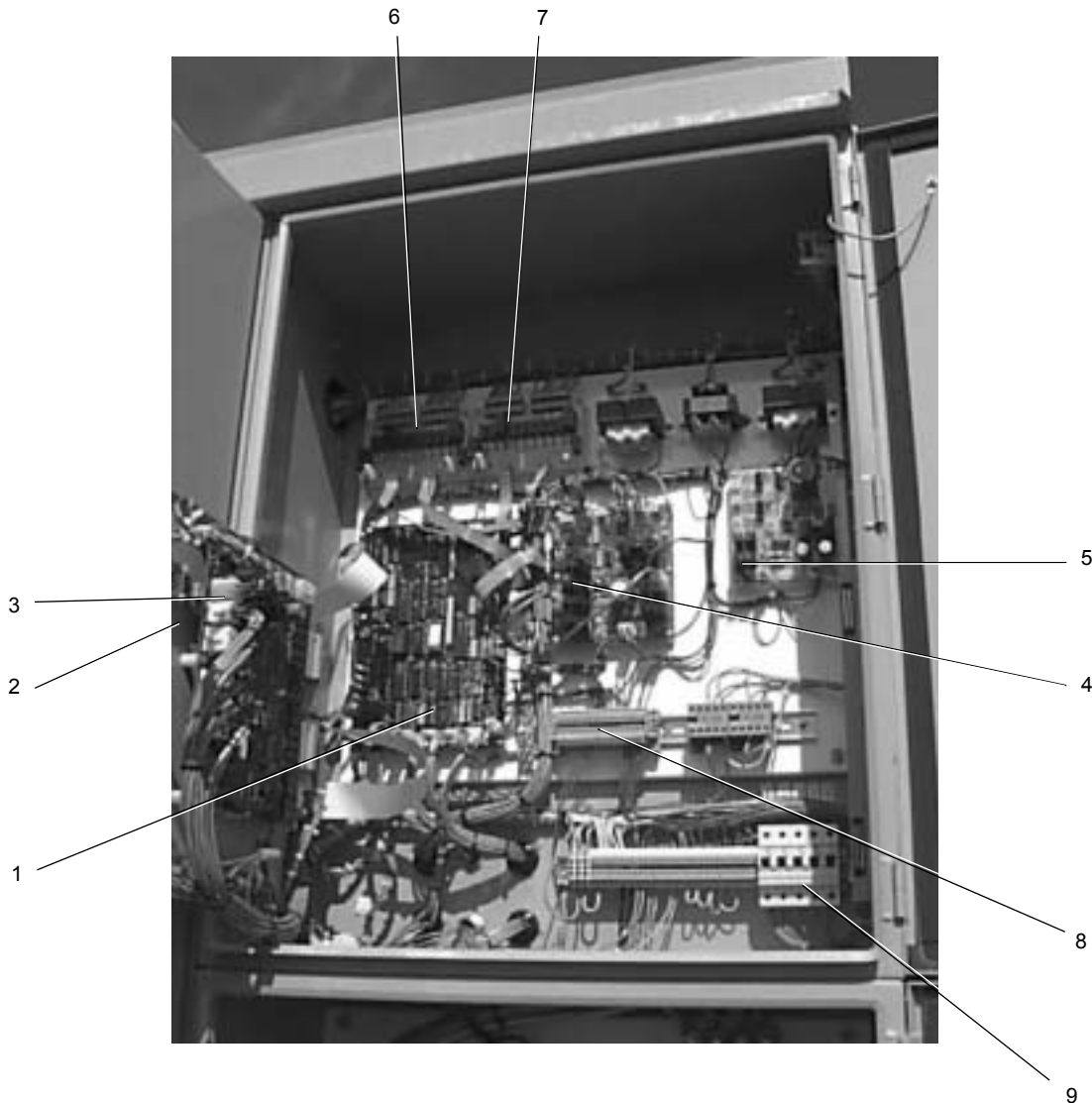

00262VIP

**PHOTOGRAPH OF  
50HZ MODEL LOGIC SECTION**

ITEM	DESCRIPTION
1	Microprocessor Board
2	Back of Keypad
3	I/O Expansion Board # 2
4	I/O Expansion Board # 1
5	Power Supply Board
6	Relay Output Board #1
7	Relay Output Board #2
8	Flow Switch & Customer Connection Terminals (TB4)
9	Circuit Breakers

**FIG. 74 – LOGIC SECTION LAYOUT**

### 1.13 ANTI-RECYCLE TIMER

The programmable Anti-Recycle Timer allows the user to select the compressor anti-recycle time to best suit their needs. Motor heating is a result of inrush current when the motor is started. This heat must be dissipated before another start takes place or motor damage may result. The anti-recycle timer assures that the motor has sufficient time to cool before it is restarted.

An adjustable timer allows for the motor cooling, but gives the user the ability to extend the anti-recycle timer to cut down on cycling. In some applications, faster compressor start response is necessary and shorter anti-recycle times are required. These needs should be kept in mind, but whenever possible the timer should be adjusted for the longest period of time tolerable. 600 seconds is recommended, although 300 seconds provides adequate motor cooling time. Longer periods will allow more heat dissipation, reduce cycling, and possibly increase motor life. See Section 8.2, page 181 for programming of the anti-recycle timer.

### 1.14 ANTI-COINCIDENCE TIMER

The Anti-Coincidence Timer assures that 2 systems do not start simultaneously. This assures that inrush current is kept to a minimum. A 60 second time delay will always separate motor starts. This timer is not programmable.

### 1.15 EVAPORATOR PUMP CONTROL

Dry contacts are provided which transition (close) when the Daily Schedule is calling for chiller operation, the unit switch is on, and power has been applied to the Micro Panel for 30 seconds. If for some reason the evaporator pump contacts have been closed to run the pump and a power loss or Daily Schedule shuts the pump down (contacts open), the contacts will not reclose for any reason until 30 seconds has elapsed after power re-application or 30 seconds have elapsed between a Daily Schedule shutdown and restart. If the daily schedule is not used (ON/OFF times equal 00:00) the contacts will be closed at all times.

### 1.16 COMPRESSOR HEATER CONTROL

Each compressor has its own heater. The heater will be off whenever the compressor is running. As soon as the compressor shuts off, the heater will turn on and stay on for 5 minutes. After 5 minutes has elapsed, the heater will shut off if the discharge temperature rises above 150 °F (66°C) and will turn on when the discharge temperature is equal to or less than 150 °F (66°C).

### 1.17 EVAPORATOR HEATER CONTROL

The evaporator heater is controlled by ambient temperature. When the ambient temperature drops below 40°F (4°C), the heater is turned on when the compressors are turned off. When the temperature rises above 45°F (7°C), the heater is turned off. An under voltage condition will keep the heater off until full voltage is restored to the system. The heater will provide freeze protection to -20°F (-28°C).



***115VAC power must remain “ON” through CB4 (3 System chillers) or CB5 (4 System chillers) for freeze protection. Otherwise, the evaporator must be drained.***

### 1.18 PUMPDOWN (EEV) CONTROL

Each compressor undergoes a pump down on shutdown. This assures that liquid refrigerant does not enter the compressor on start-up, eliminating the need for recycling pump down, saving energy and reducing compressor starts and wear.

On start-up, the controls unload the compressor and immediately energize the pilot solenoid on the electronic expansion valve. Normal operation commences without pumpdown.

On shutdown, the microprocessor controls unload the compressor, the pilot solenoid on the electronic expansion valve is de-energized, and the Economizer Liquid Supply Solenoid Valve is de-energized. The compressor continues to operate until it either pumps down to the low suction pressure cutout setting or for 180 seconds, whichever comes first. Pump down occurs on “normal” shutdowns where cooling demand has been satisfied or when a system switch is turned off, a flow switch opens, run permissive is lost or a Daily Schedule or a Remote Shutdown is called for.

No pumpdown will occur on a safety shutdown. See page 144 for the pumpdown display message.

Remote evaporator applications equipped with thermostatic TXV and liquid line solenoid will also pump down on shutdown.

## 1.19 ALARMS

Internal contacts are provided in the Micro Panel (See Section 1.12) which can be used to remotely signal a warning whenever a fault lockout occurs on any system or if power is lost to the control panel. The internal contacts are normally open (N.O.) and will close when control power is applied to the panel, if no fault conditions are present. When a fault occurs which locks out a system, the respective contacts open. If chiller power is lost or a unit fault occurs, such as a Low Water Temp fault, contacts for all systems will open.

Contacts for SYS 1 are located on the bottom right of the microprocessor panel, terminals 23 and 24. SYS 2 contacts are located on terminals 27 and 28, SYS 3 on terminals 37 and 38, and SYS 4 on terminals 41 and 42. See Fig. 11, Page 36 for the location of these terminals.

A 28VDC or 120VAC (60 Hz models) or up to 240VAC (50 Hz models) external alarm circuit (supplied by others) may be connected to these contacts. The contacts are rated at 125VA.

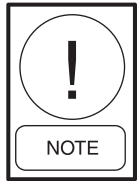

***If any inductive load devices (relay or contactor) supplied by the user are in the electrical circuit connected to the dry alarm contacts, the device must be suppressed at the load with a RC suppressor YORK Part Number 031-00808-000 across the inductive coil. Failure to install suppressors will result in nuisance faults and possible damage to the chiller.***

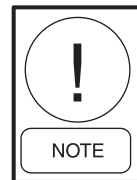

***If the alarm circuit is applied in an application used for critical duty (such as process duty or cooling other critical equipment) and the alarm circuit should fail to function, YORK will not be liable for damages.***

## 1.20 RUN STATUS (CHILLER)

Internal Chiller Run Status contacts between Terminal 28 and 29 close whenever one of the systems is running. These contacts are located on the bottom right of the Microprocessor Board and are rated (voltage and current) the same as the alarm contacts (Section 1.19). Also use a suppressor, same as alarm contacts (Section 1.19). Individual system "Run Status" contacts are not available.

## 1.21 LEAD / LAG COMPRESSOR SELECTION

The chiller may be set up for AUTO or MANUAL Lead / Lag. This is accomplished by programming the option under the Program Key. Details for programming the Manual/Auto Lead/Lag Selection are discussed in Program Key Section 8.

When AUTO Lead/Lag is utilized, the micro attempts to balance run time between the two compressors. A number of conditions can occur which will prevent this from happening. Factors determining lead/lag selection and the resulting lead/lag determination are:

1. The micro automatically defaults the lead to SYS 1 and the lag to SYS 2 if both compressors are ready to start (Anti-recycle Timers timed out) and compressors have equal run time.
2. In YCAS 3 System models, SYS 2 is assigned first lag and SYS 3 the second lag. The same lead/lag assignment occurs with YCAS 4 System models with SYS 4 assigned as the third lag. Individual system run status is not present.
3. If all compressors are ready to start (Anti-recycle timers timed out), the compressor with the lowest run hours will start first.
4. If all compressors are waiting to start (Anti-recycle timers have not timed out), the micro will assign the lead to the compressor with the shortest anti-recycle time in an effort to provide cooling quickly.
5. If the lead compressor is locked out, faulted and waiting to restart, SYS switch on the microboard is off, or a run permissive is keeping an individual system from running, the lag (first lag in YCAS 3 System and YCAS 4 System models) compressor is swapped to the lead. This is true regardless of whether the lag compressor is ON or OFF.

MANUAL Lead/Lag selection will be automatically overridden by the micro to allow the lag compressor to automatically become the lead anytime the selected lead compressor shuts down due to a lock-out, lead system faults and is waiting to restart, system switch on the micro board is in the OFF position, or if a run permissive is keeping the lead of the system off. Automatic switchover in MANUAL mode is provided to try to maintain chilled liquid temperature as close to setpoint as possible.

## 1.22 3 OR 4 COMPRESSOR CHILLER CONFIGURATION

The EPROMs are identical in 3 and 4 compressor units. To place the software in 3 compressor mode, a jumper must be connected between J4-3 and +24V on the microboard. This connection can be made between terminals 13 and 75 on the terminal block. If the jumper is not installed, the unit will operate as a 4 compressor unit.

## 1.23 ECONOMIZER SOLENOID CONTROL

The economizer solenoid is controlled by the micro based on the ability of the economizer to provide extra capacity according to system operating conditions. This ability is primarily based on outside ambient temperature. If the ambient is low with associated low discharge pressure, the economizer will provide very little extra subcooling. At an ambient of 90°F (32°C) or above with associated high discharge pressure, the economizer will begin to provide appreciable additional subcooling. The extra subcooling may be as much as an additional 20°F to 25°F (-7°C to -4°C), often making the total subcooling at the TXV over 40°F (4.4°C).

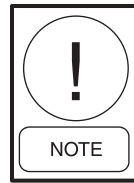

*This should not be confused with subcooling at the liquid valve, which should generally be 12°F to 15°F (6.7°C to 8.3°C). The micro monitors the difference in pressure ratio between the discharge and suction pressure along with the step of unloading to determine economizer solenoid on/off points.*

The micro utilizes the formula below to compute pressure ratio:

$$PR = \frac{(DP \text{ in PSIG}) + 14.7}{(SP \text{ in PSIG}) + 14.7}$$

For the first 3 minutes of operation, the micro will not energize the solenoid. After 3 minutes of operation. If the step of unloading is above step 47 and the  $PR > 2.2$ , the micro energizes the economizer solenoid.

Once on, the solenoid will remain on until the  $PR < 2.0$  or the step of unloading falls below 44. If the conditions drop below either of these points, the micro will turn off the solenoid.

Economizer cycling is reduced by 2 timers. The timer with the longest remaining time will dictate when the economizer can turn on. The first timer is an "on to on" timer which assures at least 10 minutes elapses from the time the economizer turns on, off, and then on again a second time. The second timer assures that a minimum of 3 minutes elapses from the time the economizer turns off to the next time it is called to turn on again.

This page intentionally left blank.

## 2. STATUS KEY: GENERAL STATUS MESSAGES & FAULT WARNINGS



29023A

### 2.1 GENERAL

Pressing the Status key displays the current chiller or individual system operational status. The messages displayed include running status, cooling demand, fault status, external cycling device status, load limiting, and anti-recycle timer status. The display will show one message relating to the “highest priority” information as determined by the microprocessor.

For individual system status or fault messages, the display shows information for up to two refrigerant systems.

The main categories of messages available using the Status key are:

- 2.2 General Status Messages
- 2.3 Unit Warnings
- 2.4 Anticipation Control Status Messages
- 2.5 Chiller Fault Status Messages
- 2.6 System Fault Status Messages

These messages are described in detail below, with examples of each display. In each example “#” is used as applicable to represent the system number where messages apply to individual systems.

### 2.2 GENERAL STATUS MESSAGES

#### Unit Switch OFF:

UNIT SWITCH OFF  
SHUTDOWN

This message indicates that the Chiller ON / OFF Switch on the Control Panel is in the OFF position which will not allow the chiller to run.

#### Schedule Shutdown:

DAILY SCHEDULE  
SHUTDOWN

This message indicates that the that the chiller has been shut down by the daily schedule programmed into the Clock - Set Schedule / Holiday (Section 7.3).

#### Remote Controlled Shutdown:

REMOTE CONTROLLED  
SHUTDOWN

This message indicates that either an ISN or RCC (Remote Control Center) has turned the unit OFF through the RS-485 port.

#### Compressors Running:

SYS # COMP RUNNING  
SYS # COMP RUNNING

This message indicates that the respective compressor is running due to demand.

**System Switches OFF:**

```

SYS #1 SYS SWITCH OFF
SYS #2 SYS SWITCH OFF

```

This message indicates that the system switch on the Microprocessor Board for the respective system is in the OFF position. A system can only run if the system switch is in the ON position. The switches for System 1-3 or 1-4 should normally be in the ON position for 3 and 4 compressor chiller models. See Figure 73, page 142 for the location of the system switches.

**Anti-Recycle Timers:**

```

SYS # AR TIMER 10 S
SYS # AR TIMER 120 S

```

The anti-recycle timer message shows the amount of time remaining before a compressor can be called to restart. The 300 - 600 sec. programmable timers begin timing when a compressor starts, although a minimum of two minutes must always elapse after a compressor shuts down, before it may again restart. If a power failure occurs, the anti-recycle timers will reset to 120 seconds after power is restored. The purpose of the timer is to allow for motor cooling to dissipate the heat generated by inrush current at start-up.

**Anti-Coincidence Timers:**

```

SYS # COMP RUNNING
SYS # AC TIMER 22 S

```

The anti-coincident timer guards against two or more compressors starting simultaneously. This avoids excessive instantaneous starting currents. A minimum of 60 seconds between compressor starts is maintained even if demand is present and the anti-recycle timers are timed out. The display shows the time before the respective compressor can start. This display will only appear after the anti-recycle timers have timed out.

**Run Permissive Contacts OPEN:**

```

SYS # NO RUN PERM
SYS # NO RUN PERM

```

This display indicates that an external cycling contact and/or the flow switch connected to terminals 13 & 14 in the Logic Section of the control panel is open. Whenever the contact is open, the No Run Permissive message will be displayed and the indicated system will not run.

**System Loading Requirement:**

```

SYS # NO COOL LOAD
SYS # NO COOL LOAD

```

This message indicates that chilled liquid temperature is below the point where the microprocessor will bring the lead system on and/or that the loading sequence has not loaded the chiller far enough to bring the lag system on. The lag system will display this message until the loading sequence is ready for the lag system to start.

```

MANUAL
OVERRIDE

```

If the MANUAL OVERRIDE key is pressed during a scheduled time clock shutdown, the STATUS display will display the MANUAL OVERRIDE message indicating that the schedule is being intentionally overridden. Typically MANUAL OVERRIDE is only used in an emergency. As a result, the message is a priority message and will override other STATUS messages.

**2.3 UNIT WARNINGS**

Unit Warnings are often caused by conditions which require operator intervention to start the unit or extreme operating conditions. All setpoints and programmable values should be checked, if a chiller shutdown occurred, before restarting the chiller. Unit Warnings are not logged into the HISTORY BUFFER.

**Low Battery Warning**

```

!! LOW BATTERY !!
CHECK PROG / SETP / TIME

```

On power-up the microprocessor will check the RTC (Real Time Clock) memory back-up battery to make sure it is still operational. Provided the battery checks out, operation will continue normally. If a check is made and the battery has failed, the microprocessor will not allow the chiller to run and the above Status message will appear.



*If a low battery condition exists, the micro will restore programmed cut-outs, setpoints, and schedules to their default values.*

Once a low battery condition is detected, the only way to run the chiller is to use the Manual Override key - see Section 8.7.4. This allows reprogramming of setpoints, cutouts, and schedule.

The U13 RTC chip should be replaced as soon as possible with Part # 031-00955-000. Otherwise, the chiller will shutdown and lose all programmed points, and require a MANUAL OVERRIDE restart, if a power failure occurs.

**Pump Down:**

```
SYS 1 PUMPING DOWN
SYS 2 PUMPING DOWN
```

This message indicates that a refrigerant system is in a pumpdown cycle. Pumpdown display messages occur on shutdowns where the cooling load has been met, or when a system switch is turned OFF. Note that only one compressor could be pumping down, as shown in the following display:

```
SYS 1 PUMPING DOWN
SYS 2 COMP RUNNING
```

See Section 1.18 for details of pumpdown control.

**Incorrect Refrigerant Warning:**

```
REPROGRAM TYPE OF
REFRIGERANT TO RUN
```

The incorrect Refrigerant Warning will occur if the DIP Switch setting for refrigerant type and the type programmed into the micro “at the factory” under the Service Mode are not the same. This message will be displayed until the non-programmable “factory” programmed refrigerant type and DIP Switch setting agree. See Page 193 for Service Mode programming

**Power Failure Warning:**

The Power Failure Warning will only be displayed on “power restoration” after a “power loss,” if manual restart on power failure is selected under the PROGRAM key (page 182). If manual restart on power failure has been selected, the following warning message is displayed indefinitely on power restoration and the chiller will not run until the UNIT Switch is cycled OFF-and-on to restart the unit. This safety is available for users who desire a chiller lock-out on power failure.

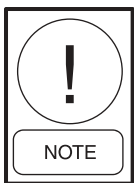

*This is typically not a desirable feature to select. Most applications require auto-reset after a power failure. Therefore, "Automatic" is typically selected and programmed under the PROGRAM key. See page 182.*

```
!! POWER FAILURE !!
CYCLE UNIT SWITCH
```

When this message appears, the chiller will not run and the Unit Switch must be cycled OFF and ON to start the unit.

**Incorrect Unit Type Warning:**

```
REPROGRAM
UNIT TYPE
```

The incorrect Unit Type Warning will occur if the DIP Switch setting for unit type and the type programmed into the micro "at the factory" are not the same. This message will be displayed until the "factory" programmed unit type and DIP Switch setting agree. See Page 193 for Service Mode Programming.

**2.4 ANTICIPATION CONTROL STATUS MESSAGES**

Anticipation controls are built into the software to prevent safety shutdowns by automatically overriding the temperature controls, if system conditions approach safety thresholds. This avoids total loss of cooling resulting from a lockout by a safety control.

Anticipation controls monitor discharge pressure, motor current and suction temperature for each compressor and if maximum limits are approached, the slide valve loading of the respective compressor will be reduced to avoid exceeding the limit.

Displays of anticipation safety control messages and their meanings are as follows:

**Discharge Pressure Limiting:**

```
SYS # DSCH LIMITING
SYS # DSCH LIMITING
```

Discharge Pressure Limiting takes effect when compressor discharge pressure nears the point at which the high pressure cutout would shut the system down. When the above message appears, discharge pressure has exceeded the programmable threshold and the compressor is being unloaded in an effort to prevent shutdown on the high pressure cutout. The operation of this safety is important if condenser coils become dirty, if there is a problem with the condenser fan operation, or if extreme ambient or load conditions occur. See Anticipatory Unloading Controls Page 173 for detailed operation.

**Compressor Motor Current Limiting:**

```
SYS # CURR LIMITING
SYS # CURR LIMITING
```

The Motor Current Limiting message indicates that a compressor motor current has reached a programmable threshold or a BAS/current limit threshold, and the system is being unloaded to assure that motor current does not become excessively high causing a fault. See *Anticipatory Unloading Controls Page 173 for detailed operation.*

**Suction Temperature Limiting:**

```
SYS # SUCT LIMITING
SYS # SUCT LIMITING
```

This message indicates that saturated suction temperature on a system has dropped to 24°F (-4.4°C) in the water cooling mode. Any further temperature reduction could cause some icing of the evaporator tubes. Saturated suction temperature is computed by the micro by converting suction pressure to temperature. See Anticipatory unloading controls page 173 for detailed operation. Suction limiting is not active in the glycol mode.

**2.5 UNIT FAULT STATUS MESSAGES**

A Unit Fault will shut the entire chiller down when a preset safety threshold is exceeded. The chiller will automatically restart after the condition causing the shutdown clears. Restart will occur only after anti-recycle timers are satisfied and cooling demand requires additional cooling. A reset hysteresis is built into each safety so repetitive faulting and clearing will not occur in a short time period.

Continuous monitoring by the microprocessor assures that instantaneous reaction results. When the chiller is shut down on one of these safeties, a message will appear on the Status display informing the operator of the problem as shown in the text that follows.

Any time that a Unit Fault occurs, the shutdown will be logged into the HISTORY BUFFER.

**Low Ambient Temperature Cutout:**

```
UNIT FAULT
LOW AMBIENT TEMP
```

The Low Ambient Temperature Safety prevents the chiller from running in very low temperatures which could cause damage due to low system pressures. This feature is programmable and can also be used to shut down the chiller at a temperature where continued run-

ning of the chiller is not economical compared to the use of “free” cooling techniques (see also Section 8.2 / Low Ambient Temperature Cutout [page 180]). The fault will clear when ambient temperature rises 2°F (1°C) above the cut-out.

**High Ambient Temperature Cutout:**

```
UNIT FAULT
HIGH AMBIENT TEMP
```

The High Ambient Temperature Safety protects the chiller from running in ambients above 130°F (54°C) where potential malfunction of system mechanical and electrical components may result. The High Ambient Cutout is programmable and can be set for lower limit values if required (see also Section 8.2 / High Ambient Temperature Cutout [page 180]). The fault will clear when ambient temperature drops 2°F (1°C) below the cut-out.

**Low Leaving Chilled Liquid Temperature Cutout:**

```
UNIT FAULT
LOW LIQUID TEMP
```

The Low Liquid Temperature Safety assures that the evaporator is not damaged from freezing due to improperly set control points. It also attempts to protect the chiller from freezing, if the flow switch should fail. However, the flow switch should always be regarded as the primary safety. Whenever the chilled liquid temperature drops below the programmable cutout, the chiller will shut down (see also Section 8.2 / Leaving Water Temperature Cutout, page 180). The chiller fault will clear when temperature rises 4°F (2°C) above the cut-out and cooling demand exists.

**115VAC Under Voltage Cut-Out:**

```
UNIT FAULT
115VAC UNDER VOLTAGE
```

The Under Voltage Safety assures that the system is not operated at voltages where malfunction of the microprocessor could result in system damage. Whenever the microprocessor senses an on-board control power supply failure while a compressor is running, the chiller is shut down. The microprocessor circuitry is capable of operating at voltages 10% below the nominal 115VAC supply to the panel. Auto-restart of the chiller occurs after a 2 minute start-up timer has elapsed from the time when power is reapplied, if the AUTO RESTART ON POWER FAILURE is enabled. Otherwise the chiller must be manually reset. See Section 8.2 (page 182).

**Flow Switch Open:**

```
SYS # NO RUN PERM
SYS # NO RUN PERM
```

Closure of the flow switch is monitored to check that flow is present in the evaporator when a compressor is running. Any external cycling devices fitted by the customer are connected in series with the flow switch. YCAS chillers require a single flow switch wired to the control panel. If the flow switch opens, all systems will shut down and a NO RUN PERM (Permissive) message will be displayed. Closing of the flow switch, when flow is present, will cause the message to disappear and auto-restart to occur.



*Never bypass a flow switch. This will cause damage to the chiller and void any warranties.*

**2.6 SYSTEM FAULT (SAFETY) STATUS MESSAGES**

A System Fault will shut the affected system down whenever a preset safety threshold is exceeded for 3 seconds. Automatic restart will occur after the first 2 shutdowns when the anti-recycle timer times out and temperature demand exists. After any combination of 3 Manual Reset Safeties in a 90 minute time period, the affected system will shut down and lock out on the last fault. When one or more systems are shut down on one of these safeties, a message will appear on the Status display informing the operator of the problem.

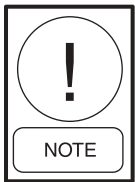

*The High Motor Current Safety is a unique safety which will lock out a system after only a single fault.*

To reset a locked out system, turn the System Switch for the affected system to the OFF position, then back to the ON position (see Section 8.1.11, Page 142, Fig. 73 for switch locations).



*Before returning a locked out system to service, a thorough investigation of the cause of the fault should be made. Failure to repair the cause of the fault while manually allowing repetitive restarts may cause further expensive damage to the system.*

**High Discharge Pressure Cutout:**

```
SYS # HIGH DSCH PRES
SYS # HIGH DSCH PRES
```

The Discharge Pressure Safety prevents system pressure from exceeding safe working limits. This safety is a backup for the mechanical High Pressure Cutout in each system. The Discharge Pressure Safety is programmable for a range of values below the system upper limit (see Section 8.2 / Page 178, High Discharge Pressure Cutout for more details).

**High Discharge Temperature Cutout:**

```
SYS # HIGH DSCH TEMP
SYS # HIGH DSCH TEMP
```

This safety protects the compressor rotors from damage due to overheating, expansion, and breakdown of the oil film seal between the rotors. It also protects against excessive oil temperature in the discharge oil separator.

For the first 4 seconds of operation discharge temperature is ignored. After 4 seconds of operation the compressor will shut down if the discharge temperature exceeds 260°F (127°C).

**High Oil Differential Pressure Cutout:**

```
SYS # HIGH OIL DIFF
SYS # HIGH OIL DIFF
```

The High Oil Pressure Differential Safety protects the compressors against loss of proper lubrication due to oil line blockage. The “differential oil pressure” for this safety is computed by measuring discharge pressure and subtracting oil pressure returning to the compressor (Discharge - Oil = Oil PSID). Under normal operation, the oil pressure differential display will be less than 25 PSID (1.7 bar), typical 2 - 10 PSID (0.1 to 0.7 bar). If oil pressure at the compressor drops due to filter blockage, the differential pressure on the display will increase and when the maximum limit is reached, the compressor will be shut down.

This safety is activated after 3 minutes of operation. Oil pressure must be less than 65 PSID (4.4 bar) for R22 models as long as the compressor continues to run.

**Low Oil Differential Pressure Cutout:**

**SYS # LOW OIL DIFF**  
**SYS # LOW OIL DIFF**

The Low Oil Pressure Differential Safety assures the compressor receives proper lubrication by monitoring the differential between oil pressure returning to the compressor and suction pressure. Lack of a differential indicates that the compressor is not pumping and no oil is being pumped through the compressor to lubricate the bearings and rotors.

This type of oil failure will not be picked up by the High Oil Differential Safety since no flow will cause the differential through the oil piping to drop to zero.

During normal operation, differential oil pressure must be greater than 50 PSID. At start-up, the cut-out is ramped over time according to ambient temperature.

For ambients above 50°F (10°C), the Low Oil Differential Safety is activated after 1 minute of compressor operation when the oil pressure differential must be greater than 10 PSID (.7 bar). After 2 minutes it must be greater than 20 PSID (1.4 bar); after 3 minutes, 30 PSID (2 bar); after 4 minutes, 40 PSID (2.7 bar); and from 5 minutes of operation and onwards, oil pressure must remain higher than 50 PSID (3.4 bar) or the system will be shut down. For lower ambients, the linear ramp times are as follows:

AMBIENT TEMP	RAMP TIME
>50°F (10°C)	5 Minutes
>45°F (7°C)	6 Minutes
>40°F (4°C)	7 Minutes
>35°F (2°C)	8 Minutes
>30°F (-1°C)	9 Minutes
<=30°F (-1°C)	10 Minutes

**High Oil Temperature Cutout:**

**SYS # HIGH OIL TEMP**  
**SYS # HIGH OIL TEMP**

This safety assures oil temperature does not exceed a safe operating temperature which affects compressor lubrication. Typical oil temperature during normal operation will be approximately 130 - 150°F (54 - 66°C).

The High Oil Temperature Safety is activated after 2 minutes of compressor operation, after which if oil temperature is above 225°F (107°C) for more than 3 seconds, the compressor will shut down.

**Low Suction Pressure Cutout:**

**SYS # LOW SUCT PRESS**  
**SYS # LOW SUCT PRESS**

The Low Suction Pressure Cutout aids in protecting the evaporator from damage due to ice build up caused by operation at low refrigerant charge or restricted refrigerant flow. A transient timer feature prevents nuisance trips during start-up, compressor loading, etc. The Low Suction Pressure Safety is programmable (see Section 8.2 / Page 179, Low Suction Pressure Cutout for more details).

The suction pressure cut-out is ignored for the first 45 seconds of operation. During the next 180 seconds of running, suction pressure may be lower than the cutout, but must be greater than:

$$SP \text{ Cutout} = \frac{\text{Programmed Cutout} \times (\text{run Time} - 25)}{200}$$

This cutout value increases with time (10% to 100%) until after 225 seconds it equals the programmed cut-out value. If suction pressure falls below the calculated cutout value before 225 seconds of run time, the system will be shut down.

The following graph shows a typical programmed suction pressure cutout of 44 PSIG (3 bar) and its change from time = 0 sec of compressor run time to 225 seconds of compressor run time.

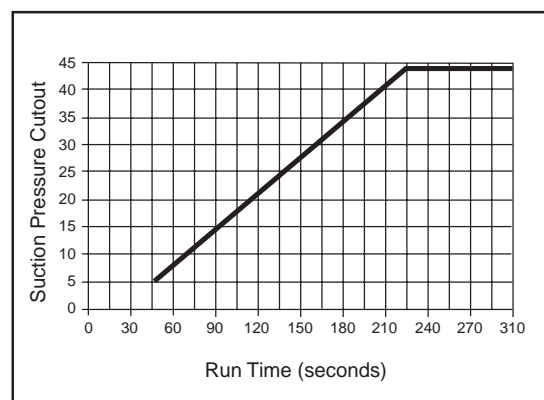

**Suction Pressure Cutout With 44 PSIG Programmed Cutout**

LD07013

**FIG. 75 – SUCTION PRESSURE CUTOUT**

After 225 seconds of operation with suction pressure operating above the cut-out, a 30 second transient timer prevents short term fluctuations in suction pressure due to loading or fan cycling from causing shutdown. If suction pressure drops below the cutout point after 225 seconds of operation, the transient timer is activated. While the transient timer is active, suction pressure must not drop below 10% of the cut-out initially programmed and must be greater than:

$$C.O. = \frac{\text{Programmed C.O. X ( Run Time -25 )}}{200}$$

This transient cutout value increases with time until after 30 seconds it equals the programmed cutout value. If the suction pressure falls below the value as calculated by the formula relative to time, the system will shut down on a low suction pressure fault. If the suction pressure rises above the programmed cutout value, the 30 second timer will be reset.

If the Dip Switch on the microprocessor board is set for "Water Cooling" (see page 168), the cutout is programmable between 44 - 70 PSIG (3-5 bar) for both R-22 and R407C models. In this mode, settings of 44 PSIG (3 bar) for R-22 and R407C are recommended. If the Switch is set for "Brine Cooling" (glycol) the cutout is programmable between 5 - 70 PSIG (0.3 - 5 bar) for R-22 and R407C models. In this mode, the cutout should typically be set to the saturated refrigerant pressure equivalent to 18°F (10°C) below the temperature of the chilled liquid.

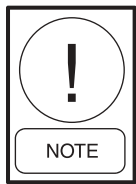

**The sludge point of the glycol MUST be at least 20°F (11°C) below the equivalent cutout temperature.**

**S Y S # 1 L O W S U P E R H E A T**  
**S Y S # 2 L O W S U P E R H E A T**

The Low Superheat Cutout is to protect the compressor(s) from liquid floodback due to low suction superheat. This safety is ignored for the first 30 seconds of system runtime.

This safety can be triggered by two events. The first is when suction superheat <0.5°F. The second is when the pilot solenoid is closed 10 times in 2 minutes due to low superheat.

**S Y S # 1 S E N S O R F A I L U R E**  
**S Y S # 2 S E N S O R F A I L U R E**

The Sensor Failure Safety prevents the system from running when the sensors measuring superheat are not functioning properly. This safety is ignored for the first 15 seconds of system runtime.

This safety will shut down a system if either suction temperature or suction pressure sensors read out of range high or low. This condition must be present for 3 seconds to cause a system shutdown. The safety locks out a system after the first fault and will not allow automatic restarting.

**High Compressor Motor Current Cutout:**

**S Y S # H I G H M T R C U R R**  
**S Y S # H I G H M T R C U R R**

The High Motor Current Safety protects against excessively high motor current and shuts a system down and locks it out after only a single occurrence of a rise in average motor current above the cutout point. Motor current is monitored using 3 Current Transformers (CTs) per motor, one on each phase. The C.T.'s are part of the Motor Protector Module.

Average motor current is monitored after 7 seconds of compressor operation. The system will be shut down if average motor current exceeds 115% FLA. This safety only requires one shutdown to lock out a system.



**FLA (full load amps) is approximately 1.08 x RLA (rated load amps). RLA is specified on the motor / chiller nameplate and is typical current demand under rated operating conditions in a fully loaded system. When a system is fully loaded, typical motor currents may be 60 - 85% FLA depending on operating conditions.**

**Low Motor Current Cutout / Motor Protector (Hi Motor Winding Temp Cutout) / Mechanical High Pressure Cutout / External Motor Overload:**

**S Y S # L O W C U R R / M P / H P**  
**S Y S # L O W C U R R / M P / H P**

The Low Motor Current Safety prevents a compressor motor running with less current than would normally be expected. This may result from loss of refrigerant, a defective contactor, power problems, or from a compressor that is not pumping due to a mechanical malfunction.

Motor current is monitored using 3 Current Transformers (CTs) per motor, one on each phase. The C.T.'s are located in the Motor Protector Module.

Average motor current is monitored after 3 seconds of compressor operation. From this time the system will be shut down if average motor current is less than 10% of FLA.

**Compressor Motor Protection Modules, and Mechanical High Pressure Cutouts** are integral to each system. All of these devices stop the compressor by removing power from the motor contactor coils. This causes the CTs to obviously sense a zero current draw by the compressor motor and causes a Low Motor Current Fault to be displayed. These devices operate as follows:

The **Motor Protection Module** protects against excessive motor winding temperature by monitoring sensors built into the motor windings. If the temperature becomes excessive, the module will cause power to be removed from the compressor contactors shutting down the compressor. Auto restart will not occur since manual reset by power removal is required. A fault lockout will automatically occur after the micro attempts 2 more starts with the MP contacts open. Manual reset is accomplished by removing 115VAC control power from the micro panel after the motor sensors have sufficient time to cool. Details relating to operation of the Motor Protection Module can be found on page 16.

The **Mechanical High Pressure Cutout** protects against excessive refrigerant discharge pressure and is set to 405 PSIG (28 bar). Auto-restart will be permitted after shutdown on discharge pressure, when the pressure drops below 330 PSIG (23 bar) and the cutout contacts close. A fault lockout will result if safety thresholds are exceeded three times in a 90 minute period.

#### Low Evaporator Temperature Cutout (R407C Only):

```
S Y S 1 L O W E V A P T E M P
S Y S 2 L O W E V A P T E M P
```

The Low Evaporator Temperature Cutout is to protect the evaporator from freeze-up with R-407C. This safety uses the Evaporator Inlet Refrigerant Temp Sensors to monitor evaporator inlet refrigerant temperature on each system. These sensors are only installed on R-407C units.

If the refrigerant temperature falls below 20°F (-6.7°C) in water cooling mode, the system will be shut down. If the refrigerant temp falls 15°F (8.3°C) below the leaving chilled liquid temp in glycol cooling mode, the system will shut down. If the evaporator inlet refrigerant temp sensor reads out of range low, the system will also shut down. The low evap temp safety is ignored for the first 3 minutes of operation. After 3 minutes of run time there is a 5 minute Low Evap Temp Safety Bypass Ramp: Any time the evaporator inlet temperature drops below the cutout, the cutout will be lowered 6°F and ramped up to original value over the next 5 minutes. If the evaporator inlet temperature rises above the original cutout during the ramp, the cutout will be reset to the original value and the ramp will be ended.

## 2.7 PRINTOUT ON FAULT SHUTDOWN

If an optional printer is installed, the contents of History Buffer 1 will be sent to the printer any time a fault shutdown occurs. This will allow record keeping of individual faults, even if they do not cause a lockout of the system. This information may be useful to identify developing problems and troubleshooting.

The No Run Permissive fault messages will not be stored in the History Buffer and will not cause an auto printout.

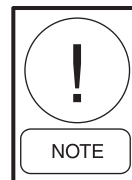

***Due to extreme operating conditions or systems where control deficiencies are present, occasional faults may occur with the corresponding automatic printout. This is not a cause for concern.***

### 3. DISPLAY KEYS & OPTION SWITCHES



29023A

#### 3.1 GENERAL

The Display keys provide direct access to retrieve commonly required data about the operation of the chiller. This is particularly useful during commissioning, monitoring the operation of the chiller, diagnosing potential future problems and service troubleshooting.

When a Display key is pressed, the corresponding message will be displayed and will remain on the display until another key is pressed.

Displayed data is in “real-time” and is updated approximately every 2 seconds. If updating of one of the messages is required faster than every 2 seconds, the appropriate key for the desired display can be pushed and held to provide updating every 0.4 seconds.

Display Messages may show characters indicating “greater than” (>) or “less than” (<). These characters indicate the actual values are greater than or less than the values which are being displayed, but are outside the ability of the micro to give an actual reading. This

is unlikely to occur unless a problem exists in the measuring sensors or during extreme conditions.

The Display keys and the data available from each is as follows:

#### 3.2 CHILLED LIQUID TEMPS KEY

When the Chilled Liquid Temperatures key is pressed a display of chilled liquid temperatures leaving the chiller (LCHLT) and returning to the chiller (RCHLT) is provided as follows:

```
LCHLT = 44.2 ° F
RCHLT = 54.0 ° F
```

If the key is pressed again, the following message will appear if an optional mixed chilled leaving temp sensor is installed for multi unit sequencing. If a sensor is not installed, pressing the key will have no effect.

```
MCHLT = 43.8 ° F
```

### 3.3 SYSTEM # DATA KEYS

Pressing one of the System # Data keys a number of times scrolls through displays of differential oil pressure (OIL), suction pressure (SP) and discharge pressure (DP), oil temperature, suction temperature (ST), discharge temperature (DT), saturated suction temperature, suction superheat, saturated discharge temperature, discharge superheat and compressor slide valve position.

Examples of these displays are shown where # is the appropriate system number:

```
SYS # OIL = 176 PSIG
SP = 64 DP = 195 PSIG
```

```
SYS # OIL = 157.4 °F
ST = 31.0 DT = 123.2 °F
```

```
S# SAT SUCT = 32.9 °F
SUCT SHEAT = 15.0 °F
```

```
S# SAT DSCH = 130.0 °F
DSCH SHEAT = 54.3 °F
```

```
SYS # S V STEP = 37
```

```
SYS # COOLER INLET
REFRIG TEMP = 28.2 °F
```

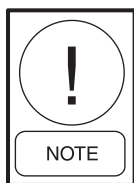

*The Evaporator Inlet Temp. display will only appear if the chiller is selected for R407C.*

Temperatures and pressures are either measured directly by transducers and temperature sensors, or computed from these measurements as follows:

Saturated discharge and suction temperatures are computed by converting measured pressure to temperature.

Slide Valve Position is computed based on the number of loading steps that the micro has sent to the slide valve solenoid in the form of a voltage signal. To the microprocessor, STEP 0 = fully unloaded and STEP 75 = fully loaded.

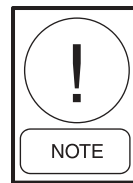

*Slide valve position is APPROXIMATE and should be used for reference only. Under actual conditions the compressor may be fully loaded between step 60 - 75 and fully unloaded between step 0 - 35.*

Superheats are the difference between the respective saturated temperature (converted from pressure) and the actual. Display Limits for the System Pressures and Temperatures displays are as follows:

	MIN. LIMIT	MAX. LIMIT
Oil Pressure	208 PSID (14 Bar)	0 PSID (0 Bar)
Suction Pressure	0 PSIG (0 Bar)	199 PSIG (14 Bar)
Discharge Pressure	0 PSIG (0 Bar)	399 PSIG (28 Bar)
Suction Temp.	* 9.0 °F (-13°C)	84.2 °F (29°C)
Discharge Temp.	40.3 °F (5°C)	302.6 °F (150°C)
Oil Temp.	40.3 °F (5°C)	240.0 °F (116°C)
Sat. Discharge Temp.	-41.0 °F (-41°C)	140.5 °F (60°C)
Sat. Suction Temp.	-41.0 °F (-41°C)	101.3 °F (39°C)
Slide Valve Position	0% (0%)	100% (100%)
Suction Superheat	* -81.5 °F (-63.1°C)	60.9 °F (16°C)
Discharge Superheat	22.5 °F (-5.3°C)	216.0 °F (102.2°C)

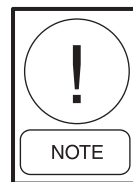

*Minimum and maximum values may change as software (EPROM) revisions are made.*



*\*Below 9.0°F (13°C), the Suction Temp. display will disappear. This will in turn cause the Superheat display to disappear.*

### 3.4 AMBIENT TEMP KEY

When the Ambient Temperature key is pressed, ambient air temperature, as measured surrounding the chiller, is displayed.

```
AMBIENT AIR TEMP
= 71.9 °F
```

Display Limits: Minimum - 4.6°F (-20.3°C)  
Maximum 137.9°F (58.8°C)

### 3.5 % MOTOR CURRENT KEY

Pressing the Motor Current key displays compressor current for each system:

```

COMP 1 = 63 AMP 85% FLA
COMP 2 = 30 AMP 41% FLA
    
```

This display shows the average motor current in amps and average compressor motor current as a percentage of FLA. All values are approximate.

```

ISN CRNT LIMIT : NONE
EMS CRNT LIMIT : NONE
    
```

On the second press of the of the Motor Current Key, the current limit values as set by the ISN (Remote BAS System) and EMS-PWM current limiting input are displayed, if they are active. See Sections 1.10, and 2.4 for more details.

### 3.6 OPERATING HRS / START COUNTER KEY

When the Operating Hours / Starts Counter key is pressed, the accumulated running hours and starts for System 1 and 2 compressors are displayed. Where applicable, pressing the key again displays the values for Systems 3 and 4 on larger models:

```

HRS 1 = 1143.2 = 1382
STR 1 = 285.2 = 322
    
```

```

HRS 3 = 1255.4 = 1095
STR 3 = 365.4 = 455
    
```

Display Limits :           Maximum run hours 99,999  
                                   Maximum starts 99,999

Values roll over to zero, if the maximum limit is exceeded.



*These counters are zeroed at the factory, but may indicate run time and number of starts logged during factory testing prior to shipment.*

### 3.7 OPTIONS KEY & DIP SWITCH SETTINGS

The Options key provides a display of options which are programmed by the positions of the S1 Dip Switches on the Microprocessor Board. Proper programming of

the switches is important during the commissioning of the chiller. The Options key can be used to verify the Dip Switch positions without looking at or handling the Microprocessor Board.

Each press of the key will scroll to the next option/dip switch setting. Option Switch Messages (S1-1 to S1-8) will then be displayed in sequence. At the end of the sequence, the display will automatically revert to the first Option Switch message.

The following is a detailed guide to programming the Dip Switches together with the associated display message provided for each selection when the Options key is pressed:

#### SWITCH 1: Water / Glycol Cooling

Open:

```

S1 - 1 CHILLED LIQUID
      WATER
    
```

Water Cooling Mode is for water cooling applications and allows the chilled liquid leaving temperature setpoint to be programmed from 40 to 70 °F (4 to 21°C). Selecting this mode also auto-programs the Low Chilled Liquid Cut-Out at 36°F (2°C) and the Suction Pressure Cut-Out at 44 PSIG (3 bar).

Closed:

```

S1 - 1 CHILLED LIQUID
      GLYCOL
    
```

Glycol Cooling Mode is for brine/glycol applications with setpoints below 40°F (4°C) and allows the chilled liquid leaving temperature setpoint to be programmed from 10 to 70°F (-12 - 21°C). In this mode, the Low Chilled Liquid Cut-Out can be programmed from 8 to 36° F (-13 to 2°C) and the Suction Pressure Cut-Out programmed from 20 to 70 PSIG (1 to 5 bar) for R-22 models and 5 to 70 PSIG (0.3 to 5 bar) for R407C models.

#### SWITCH 2: Ambient Temp. Range Low Ambient Cutout

Open:

```

S1 - 2 AMBIENT CONTROL
      STANDARD
    
```

Standard Ambient Mode auto-programs the Low Ambient Cutout setting at 25°F (-4°C) and is not adjustable.

**Closed:**

**S 1 - 2   A M B I E N T   C O N T R O L  
L O W   A M B I E N T**

Low Ambient Mode allows the Low Ambient Cut-Out to be programmed from 0 to 50 °F (-18 to 10°C). Values above 25°F (-4°C) can be used to automatically shut down the chiller when direct cooling methods become operational.

**SWITCH 3: Refrigerant**

**Open:**

**S 1 - 3   R E F R I G E R A N T  
R - 4 0 7 C**

The R-407C Mode **MUST** be selected for models using refrigerant R-407C. Incorrect selection of this switch may cause serious damage to the chiller.

**Closed:**

**S 1 - 3   R E F R I G E R A N T  
R - 2 2**

The R-22 Mode **MUST** be selected for models using refrigerant type R-22. Incorrect selection of this switch may cause serious damage to the chiller.

**SWITCH 4: Unit Type**

**Open:**

**S 1 - 4   Y C W S**

**DO NOT USE THIS POSITION.**



*Incorrect programming may cause damage to the chiller.*

**Closed:**

**S 1 - 4   Y C A S**

Place the switch in the CLOSED position selects the type of chiller as an air cooled chiller (YCAS). The switch **MUST** always be in the CLOSED position.



*Incorrect programming may cause damage to the chiller.*

**Dip Switch Physical Location and Setting**

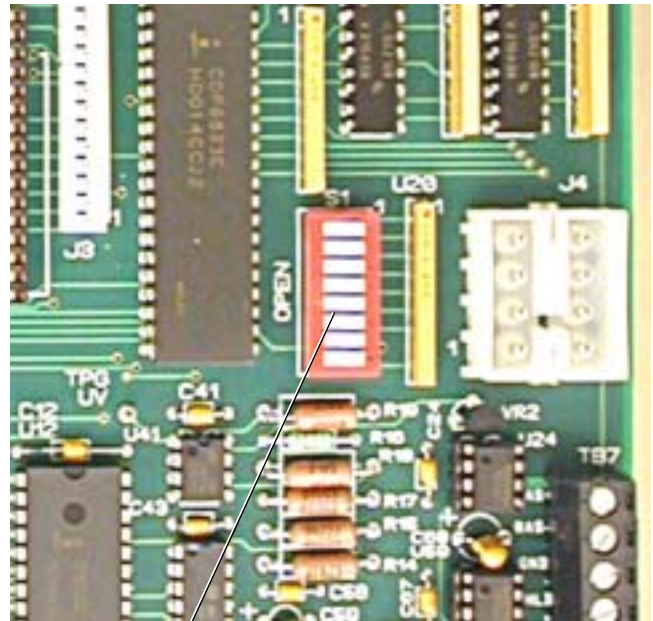

028981-G

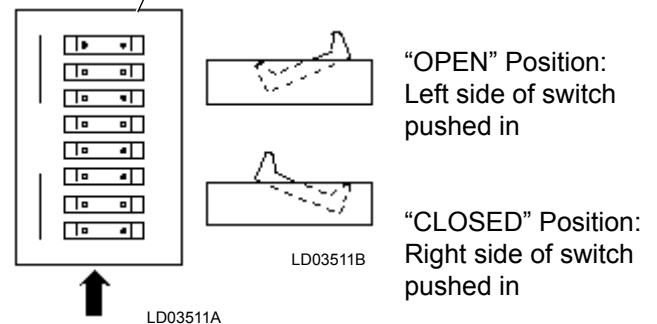

**FIG. 77 – ENLARGED PHOTOGRAPH OF DIP SWITCHES ON MICROPROCESSOR BOARD**

**SWITCH 5: Motor Current Average option (start-up)**

**Open:**

**S 1 - 5   M O T O R   C U R R E N T  
A V E R A G I N G   E N A B L E D**

**DO NOT USE THIS POSITION.**

**Nuisance trips at start-up could result.**

**Closed:**

**S 1 - 5 MOTOR CURRENT  
AVERAGING DISABLED**

Placing the switch in the CLOSED position, disables motor current averaging protection at start-up. It is recommended that this option be selected to avoid nuisance start-up trips especially at extreme ambient/operating conditions.

**SWITCH 6: Heat Recovery**

**Open:**

**S 1 - 6 HEAT RECOVERY  
DISABLED**

Placing the switch in the OPEN position, disables the heat recovery option. **The switch MUST be placed in the OPEN position.**

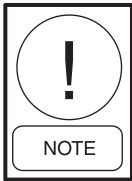

*Incorrect programming may cause damage to the chiller.*

**Closed:**

**S 1 - 6 HEAT RECOVERY  
ENABLED**

**DO NOT USE THIS POSITION.**



*Incorrect programming may cause damage to the chiller.*

**SWITCH 7: Expansion Valve Type**

**Open:**

**S 1 - 7 EXPANSION VALVE  
THERMOSTATIC**

Placing the switch in the OPEN position, configures the chiller for a TXV. TXV's will never be used on standard chiller packages. The switch **MUST NEVER** be placed in the OPEN position.

**Closed:**

**S 1 - 7 EXPANSION VALVE  
ELECTRONIC**

Placing the switch in the CLOSED position, configures

the chiller for an EEV (Electronic Expansion Valve). The switch **MUST** be placed in the CLOSED position.

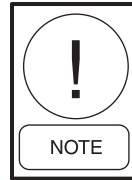

*Incorrect programming may cause damage to the chiller.*

**SWITCH 8: Spare**

Presently, Switch 8 is not used.

**Summary of Settings**

The following table gives a summary of Modes (displayed messages) which can be selected using the Open and Closed positions for each of the eight SW1 Dip Switches.

SWITCH	SWITCH "OPEN" SETTING	SWITCH "CLOSED" SETTING
1	Water Cooling	Brine Cooling
2	Standard Ambient Control	Low Ambient Control
3	Refrigerant R-407C	Refrigerant R-22
4	<u>Do Not Use</u> YCWS	YCAS
5	Not Recommended. Motor Current Average Start Protection Enabled	Recommended. Motor Current Average Start Protection Disabled
6	Heat Recovery Disabled	Do Not Use Heat Recovery Enabled
7	Do Not Use. Thermostatic Expansion Valve	Electronic Expansion Valve
8	Spare	Spare

**3.8 FUNCTION KEY**

Pressing the Function key only displays the same message as pressing the Status key. Pressing the Function key followed by another display key will scroll through all the data available under that key once. E.g., pressing the Function key followed by the System 1 Data key will result in scrolling through the 5 displays shown in Section 3.3 without the need to press the System 1 Data key to scroll to the next display. After scrolling through the data, the display returns to the status message.

The following keys can be scrolled using the Function Key: Chilled Liquid Temps, System # Data, Motor Current and Options.

## 4. PRINT KEYS



29023A

### 4.1 GENERAL

The Print keys provide access to two sets of information either locally on the panel display or, if an optional printer is connected, remotely as hard copy printouts.

The Operating Data (Oper Data) key provides a real-time list of system operating data and programmed settings. The History key provides a comprehensive list of operating data and programmed settings “at the instant of fault” on each of the last four faults.

### 4.2 OPER DATA KEY

If a remote printer is not connected, pressing the Operating Data key allows the user to scroll through information, on the 40 character display, which is not directly available from the Display keys on the panel.

If a remote printer is connected, pressing the Operating Data key causes a snapshot to be taken of system operating conditions and of the user programming selections. The data is stored in temporary memory, then transmitted from the microprocessor to the remote printer. As the data is transmitted it is erased from the memory.

Information available using the Operating Data key is de-

scribed in the following sections. In example displays “#” is used to indicate system number where appropriate.

### 4.3 OPERATING DATA – LOCAL DISPLAY MESSAGES

When the Operating Data key is pressed, the following message appears:

```

OPERATING DATA
DISPLAYS
  
```

Repetitively pressing the ↑↓ keys will scroll through the following Common (whole chiller) Data and individual System Data information displays.

#### Common Data:

```

LOAD TIMER      10 SEC
UNLOAD TIMER    0 SEC
  
```

This message shows the time remaining on the Load Timer and the Unload Timer. These Timers constantly recycle and are used in conjunction with “rate control” and “temperature deviation from setpoint” to determine when loading/unloading should occur.

```
TEMP ERROR 00.5 ° F
TEMP RATE - 0.9 ° F / M
```

The upper message indicates the difference (error) between actual leaving chilled liquid temperature and the programmed Target temperature. The lower message indicates the rate of change of the chilled liquid leaving temperature in degrees per minute. A minus sign (-) indicates falling temperature. No sign indicates rising temperature.

```
LEAD SYSTEM IS
SYSTEM NUMBER #
```

This message advises which system is programmed as the lead.

```
EVAP PUMP IS OFF
EVAP HEATER IS ON
```

This message indicates the position of the optional auxiliary contacts for the evaporator water pump and the status of the evaporator heater.

For the evaporator pump contacts, ON = contacts closed, OFF = contacts open.

The Evaporator Heater status is controlled on ambient temperature as follows: If measured ambient falls below 40°F (4°C), the Evaporator Heater is switched ON. If measured ambient then rises above 45°F (7°C) the heater is switched OFF. The evaporator heater prevents water standing in the evaporator from freezing.

```
ACTIVE REMOTE CTRL
NONE
```

This message indicates that a remote device such as a Remote Control Center, an ISN controller, or another device sending a PWM signal for temperature or current reset is overriding control points programmed through the keypad or default microprocessor setpoints. The following displays may be encountered:

NONE – No remote control active. Remote monitoring may be active.

ISN – YorkTalk via ISN or Remote Control Center (remote mode).

PWM CURR – EMS PWM Current Limiting Enabled

PWM TEMP – EMS PWM Temp. Reset Enabled

CUR/TEMP – EMS PWM Current Limiting & Temperature Reset Enabled

**System Data:**

The following sequence of three displays are provided first for System 1, then for System 2, and then for Systems 3 and 4 as applicable.

```
SYS # COMPRESSOR
IS ON
```

This message indicates whether the compressor on this system is ON or OFF.

```
SYS # MOTOR CURRENT
135 AMPS 78% FLA
```

This message indicates the compressor motor current in amps and as a percentage of Full Load Amps.

```
SYS # OIL = 175 PSIG
SP = 62 DP = 271 PSIG
```

This message indicates the system oil pressure, suction pressure, and discharge pressure.

```
SYS # OIL = 154.8 ° F
ST = 39.0 DT = 123.7 ° F
```

This message shows the system oil temperature, suction temperature, and discharge temperature.

```
S # SAT SUCT = 34.7 ° F
SUCT SHEAT = 10.5 ° F
```

These messages indicate compressor suction gas saturation temperature and superheat.

```
S # SAT DSCH = 129 ° F
DSCH SHEAT = 62.8 ° F
```

This message indicates compressor discharge gas saturation temperature and superheat.

```
SYS # SV STEP = 40
```

This message indicated the compressor slide valve position. 0 steps equals minimum capacity and 75 steps equals fully loaded.

```

SYS X EEV      = 37.4 %
SUCTION SHEAT = 10.2 °F

```

This message indicates the EEV preheat % and the suction superheat.

```

SYS # RUN TIME
1 - 3 - 48 - 17 D - H - M - S

```

This message displays the accumulated Run Time since the last start in Days (D), Hours (H), Minutes (M), and Seconds (S).

```

SYS # LLSV IS      ON
ECON TXV SOL IS    ON

```

This message indicates the Liquid Line Solenoid Valve and the economizer TXV solenoid valve position: ON = Energized/Open, OFF = De-energized/Closed.

```

SYS # FAN STAGE    3
COMP HEATER IS     ON

```

This message advises the stage of condenser fan operation on this system and the status of the compressor heater. See Section 8.4 for details of fan staging.

Once the System Data sequence has been repeated for the second system, pressing the  $\uparrow$  or  $\downarrow$  key again will loop back to the beginning to the Load/Unload Timer display. To leave the sequence at any point, press a key from another section of the keypad.

## SOFTWARE VERSION

The software version may be viewed by pressing the \* key.

The software version will be displayed similar to the sample below:

```

SOFTWARE VERSION
C . ACS . 09 . 08

```

## 4.4 OPERATING DATA – REMOTE PRINTOUT

The follow text shows a typical example printout obtained by pressing the Operating Data key with an optional printer attached. In this case, an example is shown for a YCAS 2 System Chiller. YCAS 3 System models and YCAS 4 System models provide similar printouts for the appropriate number of systems:

```

YORK INTERNATIONAL CORPORATION
MILLENNIUM SCREW CHILLER

```

```

UNIT STATUS
2:04PM 01 JUN 04

```

```

SYS 1          NO COOLING LOAD
SYS 2          COMPRESSOR RUNNING

```

### OPTIONS

```

CHILLED LIQUID          WATER
AMBIENT CONTROL         STANDARD
REFRIGERANT TYPE       R-407C
UNIT TYPE               YCAS
MOTOR CURRENT AVERAGING  ENABLED
HEAT RECOVERY          DISABLED

```

### PROGRAM VALUES

```

DSCH PRESS CUTOUT      399 PSIG
DSCH PRESS UNLOAD     375 PSIG
SUCTION PRESS CUTOUT   44 PSIG
HIGH AMBIENT CUTOUT   130.0 DEGF
LOW AMBIENT CUTOUT    25.0 DEGF
LEAVING LIQUID CUTOUT 36.0 DEGF
MOTOR CURRENT UNLOAD   100 %FLA
ANTI RECYCLE TIME     600 SECS
LOCAL/REMOTE MODE     REMOTE
LEAD/LAG CONTROL      AUTOMATIC

```

### UNIT DATA

```

LEAVING LIQUID TEMP    49.0 DEGF
RETURN LIQUID TEMP     58.2 DEGF
SETPOINT              42.0 +/- 2.0 DEGF
REMOTE SETP           42.0 +/- 2.0 DEGF
AMBIENT AIR TEMP      74.8 DEGF
LEAD SYSTEM           SYS 2
EVAPORATOR PUMP       ON
EVAPORATOR HEATER     OFF
ACTIVE REMOTE CONTROL  NONE
SOFTWARE VERSION      C.ACS.09.00

```

### SYSTEM 1 DATA

```

COMPRESSORS STATUS     OFF
RUN TIME              0- 0- 0- 0 D-H-M-S
MOTOR CURRENT          0 AMPS  0 %FLA
SUCTION PRESSURE       125 PSIG
DISCHARGE PRESSURE     131 PSIG
OIL PRESSURE           130 PSIG
SUCTION TEMPERATURE   68.4 DEGF
DISCHARGE TEMPERATURE 68.8 DEGF
OIL TEMPERATURE       68.8 DEGF
SAT SUCTION TEMP      71.8 DEGF

```

```

SUCTION SUPERHEAT      3.4 DEGF
SAT DISCHARGE TEMP     74.5 DEGF
DISCHARGE SUPERHEAT   6.3 DEGF
SLIDE VALVE STEP       0
EEV OUTPUT              0.0 %
EVAPORATOR INLET REFRIG 44.6 DEGF
LIQUID LINE SOLENOID   OFF
ECONOMIZER TXV SOLENOID OFF
CONDENSER FAN STAGE    OFF
COMPRESSOR HEATER      ON
WYE-DELTA RELAY        OFF
    
```

SYSTEM 2 DATA

```

COMPRESSORS STATUS      ON
RUN TIME                0- 0-15-26 D-H-M-S
MOTOR CURRENT          104 AMPS 87 %FLA
SUCTION PRESSURE       57 PSIG
DISCHARGE PRESSURE     233 PSIG
OIL PRESSURE           218 PSIG
SUCTION TEMPERATURE   42.9 DEGF
DISCHARGE TEMPERATURE 145.5 DEGF
OIL TEMPERATURE       102.8 DEGF
SAT SUCTION TEMP       31.7 DEGF
SUCTION SUPERHEAT     11.2 DEGF
SAT DISCHARGE TEMP    112.1 DEGF
DISCHARGE SUPERHEAT   33.4 DEGF
SLIDE VALVE STEP       70
EEV OUTPUT              35.6 %
EVAPORATOR INLET REFRIG 23.6 DEGF
LIQUID LINE SOLENOID   ON
ECONOMIZER TXV SOLENOID ON
CONDENSER FAN STAGE    3
COMPRESSOR HEATER      OFF
WYE-DELTA RELAY        ON
    
```

DAILY SCHEDULE

```

S M T W T F S      *=HOLIDAY
MON START=00:00AM  STOP=00:00AM
TUE START=00:00AM  STOP=00:00AM
WED START=00:00AM  STOP=00:00AM
THU START=00:00AM  STOP=00:00AM
FRI START=00:00AM  STOP=00:00AM
SAT START=00:00AM  STOP=00:00AM
HOL START=00:00AM  STOP=00:00AM
    
```

### 4.5 HISTORY KEY

If a safety shutdown occurs on the chiller, a comprehensive list of operating and programmed settings data is stored by the microprocessor. The information is stored at the instant of the fault, regardless of whether the fault caused a lockout to occur. This information is not affected by power failures or manual resetting of a fault lockout.

The microprocessor stores data for up to 6 safety shutdowns on 2 System units and 4 safety shutdowns on 3 or 4 compressor units. Once this limit is reached, a further shutdown will cause the oldest set of data to be discarded in favor of storing the new shutdown data. The Safety Shutdowns are numbered from 1 to 6 or 1 to 4 with number 1 always being the most recent.

If a remote printer is not connected, pressing the History key allows the operator to locally scroll through information relating to the stored safety shutdowns on the control panel display.

If a remote printer is connected, pressing the History key will cause data from the last 6 shutdowns on a 2 compressor chiller or 4 shutdowns on a 3 or 4 compressor chiller to be transmitted from the microprocessor to the remote printer. The printout will begin with the most recent fault which occurred. This does not affect the stored data and as many prints as desired may be taken. See Section 4.7 for a HISTORY printout sample.

### 4.6 FAULT HISTORY DATA – LOCAL DISPLAY MESSAGES

When the History key is pressed, the following message will appear:

```

DISPLAY SAFETY SHUT -
DOWN NO. 1 ( 1 TO 4 )
    
```

To select a Safety Shutdown, press the appropriate key on the numeric key pad, then press Enter. Remember that the most recent fault information is stored as shutdown No. 1. After the ENTER Key is pressed, a message indicating the time and date of the Fault Shutdown will appear:

```

SHUTDOWN OCCURRED
5 : 59 AM 29 NOV 02
    
```



*The System Evaporator Inlet Refrigerant Temperature will be printed if the unit is in R407C mode.*

Repetitively pressing the  $\uparrow\downarrow$  Keys allows scrolling through the information available in the Safety Shutdown buffer. This is divided into Chiller Data and Individual System Data displays as follows:

#### Chiller Data:

```
SYS 1 NO FAULTS
SYS 2 HIGH MTR CURR
```

This message indicates the fault that caused the shutdown; in this case, a high motor current in System 2 was the cause of the shutdown.

```
S1 - 1 CHILLED LIQUID
      WATER
```

This message displays the type of chilled liquid selected (water or glycol) at the time of the fault.

```
S1 - 2 AMBIENT CONTROL
      LOW AMBIENT
```

This display indicates whether standard or low ambient operation was selected at the time of the fault.

```
S1 - 3 REFRIGERANT
      R - 407C
```

This message indicates the type of refrigerant that was programmed at the time of the fault (R-22 or R407C).

```
S1 - 4      YCAS
```

This message indicates the type of Chiller (YCAS or YCWS) programmed at the time of the fault. **(MUST BE IN YCAS MODE)**

```
S1 - 5 MOTOR CURRENT
      AVERAGING DISABLED
```

This message indicates whether motor current averaging at start-up is enabled or disabled.

```
S1 - 6 HEAT RECOVERY
      DISABLED
```

This message indicates whether heat recovery is disabled or enabled. **(HEAT RECOVERY MUST BE DISABLED)**

```
S1 - 7 EXPANSION VALVE
      ELECTRONIC
```

This message indicates whether electronic or thermostatic expansion valve is selected for EEV operation. **(ELECTRONIC MUST BE SELECTED)** Remote evaporator systems will be programmed for thermostatic.

```
DISCHARGE PRESSURE
CUTOUT = 395.0 PSIG
```

This message indicates the discharge pressure cut-out programmed at the time of the fault.

```
DISCHARGE PRESSURE
UNLOAD = 375.0 PSIG
```

This display provides the discharge pressure unload point, programmed at the time of the fault.

```
SUCTION PRESSURE
CUTOUT = 44.0 PSIG
```

This message displays the suction pressure cut-out programmed at the time of the fault.

```
HIGH AMBIENT TEMP
CUTOUT = 130.0 °F
```

This message indicates the High Ambient Temperature Cutout at the time of the fault.

```
LOW AMBIENT TEMP
CUTOUT = 25.0 °F
```

This display shows the Low Ambient Cutout programmed at the time of the fault.

```
LEAVING LIQUID TEMP
CUTOUT = 36.0 °F
```

This display shows the Low Leaving Chilled Liquid Cutout programmed at the time of the fault.

```
HIGH MOTOR CURRENT
UNLOAD - 100% FLA
```

This message shows the programmed %FLA Motor Current Unload at the time of the fault.

LOCAL / REMOTE MODE  
LOCAL

This message shows whether remote or local communications was selected at the time of the fault.

LEAD / LAG CONTROL  
AUTOMATIC

This message displays the lead/lag selection programmed at the time of the fault.

LCHLT = 44.1 °F  
RCHLT = 52.9 °F

This message indicates the leaving and return chilled liquid temperature at the time of the fault.

MCHLT = 43.8 °F

This message indicates the mixed water temperature at the time of the fault. A mixed water sensor may be present when multi-unit sequencing is utilized. If no mixed water temperature sensor is installed, the display will not appear.

SETPOINT = 44.0 °F  
RANGE = + / - 2.0 °F

This message displays the programmed chilled liquid setpoint and deviation (control range) programmed at the time of the fault.

AMBIENT AIR TEMP  
77.6 °F

This message indicates the outdoor Ambient Air Temperature at the time of the fault.

LEAD SYSTEM IS  
SYSTEM NUMBER 1

This message indicates which system was in the lead at the time of the fault.

EVAP PUMP IS ON  
EVAP HEATER IS OFF

This message indicates the status of both the evaporator pump signal from the microprocessor and the evaporator heater.

ACTIVE REMOTE CTRL  
NONE

This message indicates that a remote device such as a Remote Control Center, an ISN controller, or another device sending a PWM signal for temperature or current reset is overriding control points programmed through the keypad or default microprocessor setpoints.

**System Data:**

Following the Common Data is a sequence of twenty information displays which are given twice, first for System 1, then for System 2, System 3 and finally System 4. In each example, “#” is used to indicate System number:

SYS # COMPRESSOR  
IS ON

This message indicates whether the compressor on this system was ON or OFF at the time of the fault.

SYS # RUN TIME  
1 - 3 - 48 - 17 D - H - M - S

This message shows the Run Time logged on the system since the last compressor start, in Days (D), Hours (H), Minutes (M), and Seconds (S).

SYS # MOTOR CURRENT  
135 AMPS 78% FLA

This message indicates the compressor motor current in amps and as a percentage of Full Load Amps.

```

SYS # OIL = 175 PSIG
SP = 62 DP = 271 PSIG

```

This message indicates the system oil pressure, suction pressure, and discharge pressure at the time of the fault.

```

SYS # OIL = 154.8 °F
ST = 39.0 DT = 123.7 °F

```

This message shows the system oil temperature, suction temperature, and discharge temperature at the time of the fault.

```

S # SAT SUCT = 34.7 °F
SUCT SHEAT = 10.5 °F

```

These messages indicate compressor suction gas saturation temperature and superheat at the time of the fault.

```

S # SAT DSCH = 129 °F
DSCH SHEAT = 62.8 °F

```

This message indicate compressor discharge gas saturation temperature and superheat at the time of the fault.

```

SYS # SV STEP = 40

```

This message indicates the compressor slide valve position at the time of the fault. 0 steps equals minimum capacity and 75 steps equals fully loaded.

```

SYS X EEV = 37.4 %
SUCT SHEAT = 10.2 °F

```

This message indicates the EEV preheat % and the suction superheat.

```

SYS # COOLER INLET
REFRIG TEMP = 28.2 °F

```

This message, which is only displayed if the unit is in R-407C mode, indicates the refrigerant temperature at the inlet of the evaporator.

```

SYS # LLSV IS ON
ECON TXV SOL IS OFF

```

This message indicates the EEV PILOT Solenoid Valve and the economizer Thermal Expansion Valve Solenoid Valve position: ON = Energized / OFF = De-Energized (OFF) at the time of the fault.

```

SYS # FAN STAGE 3
COMP HEATER IS OFF

```

This message indicates the stage of condenser fan operation on the system and the status of the compressor heater at the time of the fault. See Section 8.4 for details of fan staging.

```

SYS # WYE-DELTA ON

```

This message indicate whether the WYE-DELTA output to the compressor was energized at the time of the fault.

```

SYS X DSCH CL SV OFF
SYS X WYE-DELTA OFF

```

This message indicates whether the discharge cooling solenoid was energized at the time of the fault and if the WYE-DELTA output to the compressor was energized. (Low Temperature Glycol Chillers Only)

**4.7 FAULT HISTORY DATA –  
REMOTE PRINTOUT**

A printout history of unit and system operating conditions, at the time of the fault, can be obtained by pressing the HISTORY Key with an optional printer installed. 3 and 4 compressor chillers will provide a history printout on the last 4 faults.

An example of the HISTORY Printout is shown below:

```

YORK INTERNATIONAL CORPORATION
MILLENNIUM SCREW CHILLER

SAFETY SHUTDOWN NUMBER 1
SHUTDOWN @ 3:56PM 29 JUNE 04

SYS 1 HIGH DSCH PRESS SHUTDOWN
SYS 2 NO FAULTS

OPTIONS

CHILLED LIQUID WATER
AMBIENT CONTROL STANDARD
REFRIGERANT TYPE R-407C
UNIT TYPE YCAS
MOTOR CURRENT AVERAGING ENABLED
HEAT RECOVERY DISABLED

PROGRAM VALUES

DSCH PRESS CUTOUT 399 PSIG
DSCH PRESS UNLOAD 375 PSIG
SUCT PRESS CUTOUT 44 PSIG
HIGH AMBIENT CUTOUT 130.0 DEGF
LOW AMBIENT CUTOUT 25.0 DEGF
LEAVING LIQUID CUTOUT 36.0 DEGF
MOTOR CURRENT UNLOAD 100 %FLA
ANTI RECYCLE TIME 600 SECS
LOCAL/REMOTE MODE REMOTE
LEAD/LAG CONTROL AUTOMATIC

UNIT DATA

LEAVING LIQUID TEMP 49.0 DEGF
RETURN LIQUID TEMP 58.2 DEGF
SETOINT 42.0 +/- 2.0 DEGF
REMOTE SETP 42.0 +/- 2.0 DEGF
AMBIENT AIR TEMP 74.8 DEGF
LEAD SYSTEM SYS 2
EVAPORATOR PUMP ON
EVAPORATOR HEATER OFF
ACTIVE REMOTE CONTROL NONE
SOFTWARE VERSION C.ACS.09.00

SYSTEM 1 DATA

COMPRESSORS STATUS OFF
RUN TIME 0- 0- 0- 0 D-H-M-S
MOTOR CURRENT 0 AMPS 0 %FLA
SUCTION PRESSURE 125 PSIG
DISCHARGE PRESSURE 131 PSIG
OIL PRESSURE 130 PSIG
SUCTION TEMPERATURE 68.4 DEGF
DISCHARGE TEMPERATURE 68.8 DEGF
    
```

```

OIL TEMPERATURE 68.8 DEGF
SAT SUCTION TEMP 71.8 DEGF
SUCTION SUPERHEAT 3.4 DEGF
SAT DISCHARGE TEMP 74.5 DEGF
DISCHARGE SUPERHEAT 6.3 DEGF
SLIDE VALVE STEP 0
EEV OUTPUT 0.0 %
EVAPORATOR INLET REFRIG 44.6 DEGF
LIQUID LINE SOLENOID OFF
ECONOMIZER TXV SOLENOID OFF
CONDENSER FAN STAGE OFF
COMPRESSOR HEATER ON
WYE-DELTA RELAY OFF

SYSTEM 2 DATA

COMPRESSORS STATUS ON
RUN TIME 0- 0-15-26 D-H-M-S
MOTOR CURRENT 104 AMPS 87 %FLA
SUCTION PRESSURE 57 PSIG
DISCHARGE PRESSURE 233 PSIG
OIL PRESSURE 218 PSIG
SUCTION TEMPERATURE 42.9 DEGF
DISCHARGE TEMPERATURE 145.5 DEGF
OIL TEMPERATURE 102.8 DEGF
SAT SUCTION TEMP 31.7 DEGF
SUCTION SUPERHEAT 11.2 DEGF
SAT DISCHARGE TEMP 112.1 DEGF
DISCHARGE SUPERHEAT 33.4 DEGF
SLIDE VALVE STEP 70
EEV OUTPUT 35.6 %
EVAPORATOR INLET REFRIG 23.6 DEGF
LIQUID LINE SOLENOID ON
ECONOMIZER TXV SOLENOID ON
CONDENSER FAN STAGE 3
COMPRESSOR HEATER OFF
WYE-DELTA RELAY ON

DAILY SCHEDULE

S M T W T F S *=HOLIDAY
MON START=00:00AM STOP=00:00AM
TUE START=00:00AM STOP=00:00AM
WED START=00:00AM STOP=00:00AM
THU START=00:00AM STOP=00:00AM
FRI START=00:00AM STOP=00:00AM
SAT START=00:00AM STOP=00:00AM
HOL START=00:00AM STOP=00:00AM
    
```

## 5. ENTRY KEYS



29023A

### 5.1 GENERAL

The Entry keys allow the user to change numerical values programmed in as chiller setpoints, cutouts, clock, etc.

### 5.2 NUMERICAL KEYPAD

The Numerical keypad provides all keys necessary to program numerical values into the Micro Panel.

The “\*” key is used to designate holidays when programming special start/stop times for designated holidays in the SET SCHEDULE/HOLIDAY program mode.

The “+/-” key allows programming -C setpoints and cut-outs in the metric display mode.

### 5.3 ENTER KEY

The Enter key must be pushed after any change is made to setpoints, cutouts, or system clock. Pressing this key tells the micro to accept new values into memory. If this is not done, the new values entered will be lost and the original values will be returned.

The Enter key is also used to scroll through available data when using the Program or Set Schedule/Holiday keys.

### 5.4 CANCEL KEY

When the Cancel key is pressed, the cursor will always return to the first character to be programmed in the display message. This allows the operator to begin re-programming, if an error is made. When the Cancel key is pressed, the values already keyed in will be erased and the original or internally programmed default values will appear. In other instances the display will remain the same and the only reaction will be the cursor returning to the first character.

### 5.5 ↑↓ KEYS

The ↑↓ keys allow the user to scroll through data under the OPER DATA and HISTORY Key and to select the correct day of the week and the correct month when programming the micro with the correct time and date. The ↓ key also operates as a toggle AM/PM key if the cursor is over “AM” or “PM” on the display. For example, pressing the ↓ key when the cursor is on “PM” changes it to “AM.”

## 6. SETPOINTS KEYS & CHILLED LIQUID CONTROL



29023A

### 6.1 GENERAL

The microprocessor monitors leaving chilled liquid temperature and adjusts the chiller cooling capacity to maintain this temperature within a programmed range. The capacity is controlled by switching compressors on or off, and by varying a load/unload voltage to each compressor slide valve to adjust the capacity of the compressors. The microprocessor controls chilled liquid temperature through a combination of Fuzzy Logic control and internal timers. Fuzzy logic enables the micro to analyze the deviation from setpoint and the rate of change and determine the amount of loading and unloading necessary to control to the desired chilled liquid setpoint temperature. The micro also attempts to maximize efficiency by spreading the cooling load between compressors, minimize compressor cycling, and optimally utilize evaporator tube surface (maximize efficiency). This method of control is suitable for both water and glycol cooling. Control setpoints can be programmed into the chiller to establish the desired range of leaving chilled liquid operating temperatures. A description of the operation and programming follows.

### 6.2 CHILLED LIQUID TEMPERATURE CONTROL

The Setpoints keys are used to program the required chilled water liquid temperature for the application. This is accomplished by programming the “Setpoint” and the acceptable deviation (+ or - Range) This deviation is simply called the “Control Range” and is best described as the maximum acceptable + and - deviation from Setpoint.

The minimum acceptable temperature is the Lower Range Limit and is calculated by subtracting the “-” Range from the Setpoint. The Lower Range Limit is the lowest acceptable leaving temperature. The highest acceptable temperature is referred to as the Upper Range Limit and is calculated by adding the “+” Range to the Setpoint. The Upper Range Limit is the highest acceptable leaving temperature. For example, if the desired Setpoint temperature is 44.0°F (7°C) and the allowable deviation (+/- Range) from this temperature is +/- 2.0°F (1°C), then the micro will attempt to control leaving chilled liquid temperatures to 42.0°F (6°C) to 46.0°F (8°C). This can be viewed pictorially as follows:

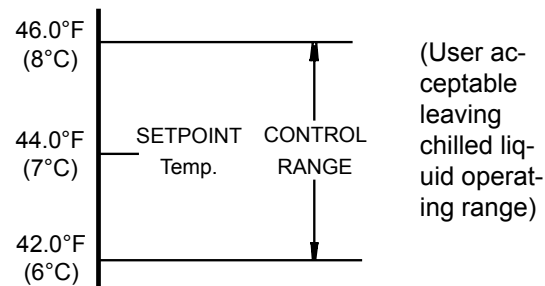

To assure that the chilled liquid leaving temperature stays within the Control Range, the micro will attempt to control the leaving temperature to the actual Setpoint temperature. This is accomplished by analyzing the temperature error and the rate of change to determine the amount of loading necessary to cool the chilled liquid to the Setpoint Temperature. The amount of loading is varied by changing the amount of DC Voltage signal to the slide valve solenoid of each compressor. Voltage increases with load (0 - approximately 9VDC at full load).

### Slide Valve Control

The slide valve of each compressor can be moved 75 steps, where “0” equals minimum capacity and fully loaded equals 75 steps. The amount of movement that occurs when the micro initiates changes may vary according to the error or deviation from setpoint and the rate of change of chilled liquid temperature. Each time a change is made, the incremental change may vary from 1 to 10 steps as determined from the micro. In cases where internal limiting is not in effect due to possible fault conditions, the micro will load the compressor with the lowest number of steps, alternating loading back and forth between compressors until both are fully loaded.

In some cases the micro will be required to make decisions regarding loading under conditions where the temperature “error” and temperature “rate” conflict. For example, the micro may elect to unload a compressor if the error is “0” (temperature is at setpoint), while the rate of change of chilled liquid temperature is negative (falling). The micro may also elect to hold capacity when error is “+” (temperature is above setpoint) because the rate of change of chilled liquid is “-”. Below is a chart which illustrates these conditions.

RATE	ERROR		
	Negative	Zero	Positive
Negative	Unload	Unload	Hold
Zero	Unload	Hold	Load
Positive	Hold	Load	Load

### Load Timers

Fixed timers are set to minimize undershoot and overshoot as a result of slide valve control.

- Load Timers are always set at 10 seconds between changes.
- Unload Timers are set at 5 seconds between changes.

### Slide Valve Position

A slide valve position (S V STEP), under the keypad system keys, of 75 indicates that the compressor is fully loaded. However due to the non-exact movement of the mechanism, a position less than 75, possibly 60, could also mean that the compressor is fully loaded. A

compressor may also be fully unloaded at step 35 and below. Keep this potential indicator error in mind when attempting to determine slide valve position versus actual compressor capacity.

### Compressor Starting & Loading Sequence

If no compressors are running, the Daily Schedule permits, all safeties and run permissives are satisfied, the anti-recycle timers have timed out, and the leaving liquid temperature rises above the upper range limit of the Control Range, the lead compressor will be started. A 0VDC signal is sent to the compressor slide valve control solenoid to allow the internal spring to push the slide valve to a minimum loading position to assure it is fully unloaded at start. At the same time, the micro will energize (open) the pilot solenoid on the EEV. After an initial period of 15 seconds, the micro will begin to load up the lead compressor to bring the chilled liquid temperature to setpoint.

After 5 minutes of run time, if leaving chilled liquid temperature is not within the Control Range, the micro will start the lag compressor. This is not dependent on slide valve position which after 5 minutes will typically be fully loaded at a S V Step of “75”. The lead compressor will be reduced in capacity to a slide valve step of 40. The lag compressor will then be loaded until it also reaches a slide valve step of 40 while the lead compressor is maintained at a constant load. At this point the compressors will be alternately loaded with loading always occurring on the compressor with the lowest slide valve step until the leaving chilled liquid is satisfied.

On 3 compressor chillers, if the two compressors cannot bring the load under control within 10 minutes, the micro will maintain the lead compressor fully loaded at S V Step 75, unload the first lag compressor to Step 40, and bring on the 2nd lag compressor. The second lag compressor will load until it reaches Step 40. From this point the compressors will be alternately loaded, always loading the compressor with the least step of loading first.

On 4 compressor chillers, loading will operate the same as a 3 compressor chiller with another compressor added to the sequence. If the load cannot be brought under control in 15 minutes, the 3rd lag compressor (compressor 4) will be started. Before starting the 3rd lag compressor, the lead and 1st lag compressor will be maintained at full load (S V Step 75) and the 2nd lag compressor will be unloaded to S V Step 40. If load continues to rise, the 2nd and 3rd lag compressor will be alternately loaded until the leaving chilled liquid temperature is satisfied.

**Compressor Loading**

The micro loads and unloads individual compressors by varying voltage to the Slide Valve solenoid which controls oil flow to the slide valve. The slide valve load solenoid applies oil pressure to the slide valve to overcome spring pressure from an internal spring, increasing capacity. The internal spring moves the slide valve in the opposite direction against oil pressure to decrease capacity.

Whenever chilled liquid leaving temperature is above the Setpoint plus the control range, loading voltage will increase to allow oil pressure to push against the internal slide valve return spring and move the slide valve to increase capacity. Every 10 seconds, when the load timer decrements to 0, the micro will increment the slide valve step from 1 to 10 steps according to error (deviation from setpoint) and rate of change of chilled liquid.

The micro will always choose the compressor with the lowest slide valve position to load on increasing demand, provided the compressor is not pumping down, has run at least 15 seconds, and is not in a "Limiting" condition.

**Compressor Unloading and Shutdown Sequence**

Whenever temperature is below the Setpoint, minus the control range, the voltage to the slide valve solenoid will decrease, which bypasses oil pressure to the slide valve allowing the slide valve return spring to move the slide valve forward to the fully unloaded position on the compressor with highest slide valve step. Every 5 seconds, the micro will decrement the compressor with the highest slide valve position by 1 - 10 steps according to the error (deviation from Setpoint) and the rate of change of chilled liquid temperature until the temperature falls within the control range.

As load drops, the micro will continue to unload the compressor with the highest slide valve step until all compressor slide valves are at "0." At this point, the last lag compressor will pump down and cycle off, if chilled liquid temperature drops below "Setpoint - Control Range/2". When the lag compressor cycles off, the lead compressor slide valve will increment to step 30. As load continues to decrease, the lead compressor will continue to unload to a slide valve position of "0" and will pump down and cycle off if the chilled liquid temperature drops below "Setpoint - Control Range."



*A lag compressor may be shut down before it is fully unloaded to avoid a Chiller fault on a Low Water Temperature cut-out under the following conditions: a) if chilled liquid temperature falls below the low end of the*

*Control Range (CR) for more than 37 seconds, b) if chilled liquid temperature drops more than CR/4 below the low limit of the Control Range.*

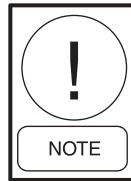

*The lead compressor may be shut down before it is fully unloaded to avoid a Chiller Fault on Low Water Temperature under the following conditions: a) if chilled liquid temperature drops 2°F below the low limit of the Control Range (CR), b) if chilled liquid temperature drops more than CR/2 below the low limit of the Control Range.*

**ANTICIPATORY LOAD LIMITING CONTROLS**

The purpose of the Anticipatory Load Limiting controls is to prevent the system from ever reaching a point where the micro would be forced to unload a system to prevent the system from reaching a safety threshold. This in turn prevents cycling of the slide valve as the micro would load and unload the system as system operating pressures and temperatures move above and below the forced unload point.

Anticipatory load limiting controls monitor motor current, discharge pressure, and saturated suction temperature. When the system is called to load in an attempt to satisfy chilled liquid temperature, the micro looks at these three operating parameters and determines if any are nearing the user programmed or internal microprocessor unload threshold points programmed into the micro panel. If the micro determines that the unload points could be exceeded, it limits the steps of loading or may decide not to provide any further loading of the specific system, even though there is a need for additional cooling. No status display will be present when anticipatory load limiting occurs.

In the case of both Motor Current and Discharge Pressure, the micro limits loading as follows based on the programmed unload point. These thresholds are outlined in the following table:

Percentage of Motor Current or Discharge Pressure Unload Point	Maximum Steps of Loading After Load Timer Counts to "0"
> 70 %	3
> 80 %	2
> 90 %	1
> 95 %	0

In the case of Saturated suction temperature, the micro limits loading based on saturated suction temperature dropping toward the point of unloading. In the water cooling mode, the saturated suction temperature unload point is 24°F. In glycol cooling mode, the control is inactive.

Temperature Difference Between Saturated Suction Temperature and the Unload Temperature	Maximum Steps of Loading After Load Timer Counts to "0"
< 7.0	3
< 4.5	2
< 2.5	1
< 1.0	0

**ANTICIPATORY UNLOADING CONTROLS**

The purpose of these controls is to prevent the system from ever reaching a point where pressure or temperature safety threshold would be exceeded shutting down a system. This is accomplished by forcibly unloading the compressor.

Anticipatory unloading controls monitor motor current, discharge pressure, and saturated suction temperature every 2 seconds and compare the values with the user or internally programmed unload points. When the system exceeds the unload point, the micro unloads the compressor based upon the difference between the actual pressure/temperature and the unload point. This action is taken even through there may be a need for additional cooling.

In the case of both the Motor Current and Discharge Pressure, the micro unloads the compressor as follows based on the user programmed unload threshold. The amount of unloading based upon the deviation versus the number of steps of unloading which will take place is outlined in the following table:

Percentage of Motor Current or Discharge Pressure Unload Point	Maximum Steps of Unloading After Load Timer Counts to "0"
> 100 %	1
> 102 %	2
> 104 %	3
> 106%	4
> 108 %	5
> 115 %	10

In the case of Saturated suction temperature, the unloading is based on saturated suction temperature dropping below the internally programmed unload threshold. In the water cooling mode, the saturated suction temperature unload point is 24°F. In the glycol cooling mode, the saturated suction temperature unload point is equal to the leaving chilled liquid setpoint -11°F (6.1°C). The unload limiting thresholds are shown in the table below:

Temperature Difference Between Saturated Suction Temperature and the Unload Temperature	Maximum Steps of Unloading After Load Timer Counts to "0"
< 0.0	1
< -0.5	2
< -1.0	3
< -1.5	4
< -2.0	5
< -3.5	10

Whenever these controls are active, a STATUS Message will appear on the display indicating the condition. See displays below:

```
SYS # DSCH LIMITING
SYS # DSCH LIMITING
```

```
SYS # CURR LIMITING
SYS # CURR LIMITING
```

```
SYS # SUCT LIMITING
SYS # SUCT LIMITING
```

**DISCHARGE TEMPERATURE ANTICIPATORY SHUTDOWN CONTROL**

If the discharge temperature nears the safety shutdown point, the micro may turn off the compressor to avoid a high discharge temperature fault.

If the discharge temperature rises above 255°F (123°C), the micro will pump down the compressor and shut it off. The micro will not allow the affected system to restart for a period of 15 minutes. A message indicating the compressor start inhibit will be displayed. An example of the display is shown below.

```
SYS # DSCH / OIL INHIB
SYS # DSCH / OIL INHIB
```

**OIL TEMPERATURE ANTICIPATORY SHUTDOWN CONTROL**

If the oil temperature nears the safety shutdown point, the micro may turn off the compressor to avoid a high oil temperature fault.

If the oil temperature rises above 220°F (104°C) and SV position is <60 steps, the micro will pump down the compressor and shut it off. The micro will not allow the affected system to restart for a period of 15 minutes. A message indicating the compressor start inhibit will be displayed. An example of the display is shown below.

```
SYS # DSCH / OIL INHIB
SYS # DSCH / OIL INHIB
```

**6.3 LOCAL COOLING SETPOINTS KEY**

The Local Cooling Setpoints key is used to program the required Leaving Chilled Liquid control temperatures for the application. When the key is pressed, the following message will be displayed:

```
SETPOINT = 44.0 °F
RANGE = +/- 2.0 °F
```

Key in the desired Chilled Liquid Setpoint and the allowable deviation (Range). The micro will accept values from 10.0 - 70.0°F (-12 to 21°C). For values below 40°F (4.4°C), Dip Switch S1, Switch #1 on the Microprocessor Board must be properly programmed for Glycol Cooling (see Section 3.7). If unacceptable values are entered, or the switch is incorrectly selected when setpoints below 40°F (4.4°C) are entered, the following message will be displayed before returning to the Control Range message:

```
OUT OF RANGE -
TRY AGAIN!
```

After the Setpoint is keyed in, the cursor will automatically advance to the first digit of the Range as shown:

```
SETPOINT = 44.0 °F
RANGE = +/- 2.0 °F
```

This value should be programmed for the maximum desirable positive and negative chilled liquid temperature deviation that is acceptable from setpoint for the system application. A typical value would be +/- 2.0°F (1.1°C). The micro will accept a range from 1.5 - 2.5°F (0.9 to 1.4°C).

After the Setpoint and Range is keyed in, press the ENTER Key to store the data in memory.

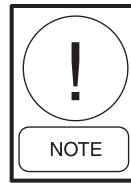

*Failure to press the Enter key will cause the newly programmed values to be ignored and not entered into memory.*

After pressing the Enter key, the display will continue to show the message until another key is pressed.

**6.4 REMOTE COOLING SETPOINTS KEY**

Remote Cooling Setpoints key allows resetting the setpoint upward from the programmed value in memory from a remote device. This feature is typically used for demand limiting or ice storage applications. Reset is accomplished by timed closure of external contacts for a defined period of time and allows reset of the setpoint upward by up to 40°F (22°C) above the setpoint programmed in memory – see Section 1.7.

The maximum allowable reset must be programmed into memory and can be a value of 2 to 40°F (1 to 22°C) depending on user requirements. To program the maximum reset, press the Remote Reset Temperature Range key. The following message will appear:

```
REM SETP = 44.0 °F
RANGE = +/- 2.0 °F
```

The display indicates the Remote Setpoint which is always equal to the chilled liquid setpoint programmed by the Chilled Liquid Temperature/Range key plus the offset from the remote reset signal. The display will also show the Range which is the programmed maximum deviation allowed for the application. The RANGE display is not programmable, and only the setpoint will change as a result of a signal from a remote device.

```
MAX EMS - PWM REMOTE
TEMP RESET = +40 °F
```

Pressing the REM RESET TEMP RANGE Key again scrolls the display to the MAX EMS-PWM REMOTE TEMP RESET which is programmable. This should be programmed to the maximum offset which is required for the application. The maximum programmable value is 40° F (22°C), while the minimum programmable value is 2°F (1.1°C).

The cursor will stop beneath the first digit of the maximum reset. Key in the maximum reset allowed for the application, remembering to use a leading “0” for values less than 10°F (or 5.6°C). Press the ENTER Key to store the new value in memory.

## 7. CLOCK KEYS



29023A

### 7.1 GENERAL

The microprocessor features a continuously running internal Clock and calendar and can display actual time as well as the day of the week and the date. An automatic schedule feature is provided for starting and stopping the chiller on individual days of the week, eliminating the need for an external time clock. Also provided are a Holiday feature, allowing special start/stop times to be set for designated holidays, and a Manual Override feature to aid servicing. If the automatic schedule feature is not required, the micro can be programmed to run the chiller on demand as long as the Chiller ON/OFF and System switches are in the ON position.

Programming of the internal clock/calendar and operating schedule are described below.

### 7.2 SET TIME KEY

When the Set Time key is pressed, a message showing the day, time and date will be displayed with the cursor below the first digit of the time as shown:

```
T O D A Y   I S   M O N   1 1 . 1 2 A M
                1 9   F E B   2 0 0 3
```

First press the ↑ or ↓ key until the proper day appears. Press ENTER to move on to the hour part of the display. Next, key in the time (hours/minutes) using a leading

“0” for times before 10 o’clock. e.g. 08:31. The cursor will then advance to the AM/PM designation. If necessary press the ↑ or ↓ key to change to the opposite time period.

Next, key in the day of the month (the cursor will automatically skip from AM/PM to the first digit of the date when a “number key” is pressed). The cursor will then skip to the first digit of the year. Key in the year. Always use two digits for the day and the year, using a leading “0” for days 1-9 e.g. 02 FEB 03. Finally, change the month as needed by repetitively pressing the ↑ or ↓ key until the proper month appears. Once the desired information is keyed in, it must be stored into memory by pressing the Enter key.

Any valid time or date will be accepted. If an out of range value is entered, the following message will be displayed for 3 seconds then revert back to the Set Time display message for reprogramming:

```
O U T   O F   R A N G E   -
T R Y   A G A I N   !
```

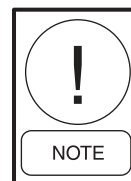

**Pressing the Set Time key once, enters the “programming” mode in which the displayed time does not update. Pressing the Set Time key a second time enters “display” mode in which the cursor will disappear and the “live” clock will be displayed.**

### 7.3 SET SCHEDULE / HOLIDAY KEY

Messages showing each week day and the holiday start/stop schedule, as shown below, can be displayed using the Set Schedule / Holiday key:

```

MON  START  =  06 : 00  AM
      STOP   =  05 : 30  PM
    
```

The displays for each day are scrolled through by repetitively pressing the set Schedule/Holiday key. To re-program any of the daily schedules, key in the new Start time then, if necessary, change the associated AM/PM by pressing the ↑ or ↓ key.

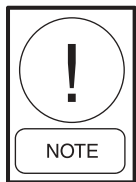

*The ↑ or ↓ key can only be pressed once to change AM/PM. If an error is made, press Cancel and begin again.*

Next key in the Stop Time (the cursor will automatically skip from AM/PM to the first digit of the stop time when a “number key” is pressed) and the AM/PM if necessary. Now press the ENTER key to store the new schedule. The display will scroll to the next day. If an unacceptable time is entered, the following message will be displayed for 3 seconds then return to the schedule display:

```

OUT OF RANGE
TRY AGAIN!
    
```

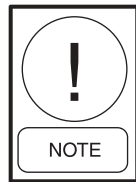

*New start/stop times programmed for Monday are automatically used for all of the following days of the week.*



*Always use the Set Schedule/Holiday key, not the Enter key to scroll through the schedule displays. Pressing the ENTER key after viewing Monday will change times programmed for the remainder of the week to the Monday schedule.*

If the chiller is not cycled by the Daily Schedule, but is required to run whenever remote cycling devices, system switches, and main Chiller ON/OFF switch are in the ON position, all 00.00s should be programmed into the daily schedule. This can be done manually for individual days or for all days by pressing Cancel and Enter for the Monday Start/Stop schedule.

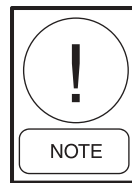

*Programming the DAILY SCHEDULE will not affect the holiday schedule.*

If the chiller is not required to run on a given day, the Start time should be programmed for 00:00 AM and the Stop time programmed for 12:00 AM.

Continue to program each day as needed. After SUN has been entered, the Holiday message will be displayed:

```

HOL  START  =  08 : 30  AM
      STOP   =  12 : 00  PM
    
```

The Holiday (HOL) Start / Stop allows a specific day(s) to be assigned for special requirements. This is provided so that a day(s) needing special start / stop requirements can be programmed without disturbing the normal working schedule. The start / stop times for the Holiday schedule are programmed just as any other day.

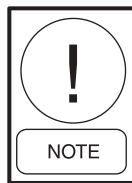

*Only one start/stop time can be programmed which will apply to each of the Holiday days selected.*

After the Enter key is pressed, a display to designate which days of the week are holidays will appear:

```

S * M T W T F S
HOLIDAY NOTED BY *
    
```

When the display appears, the cursor will first stop after Sunday as shown. To designate a day as a holiday, press the “\*” key. If a day marked as a holiday is not to be a holiday, press the “\*” key. When the “\*” key is pressed, the cursor will advance to the next day. Use the ↑ or ↓ keys to move back and forth among days. After all the holiday days are programmed, press Enter to store the new data. The display will then return to the beginning of the Daily Schedule (MON).

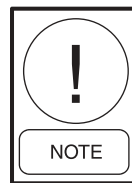

*The Holiday Schedule is only executed once, then erased from memory. This avoids the need for reprogramming after the holiday, as most special Holiday Schedule requirements occur only occasionally.*

If an error is made while programming or a change is required, press Cancel. This will clear the programmed (\*) "Holiday" days (the "0" key will not cancel out a "\*" and cannot be used for correcting a programming error).

#### 7.4 MANUAL OVERRIDE KEY

When the Manual Override key is pressed, the Daily Schedule programmed into the chiller is ignored and the chiller will start up when water temperature is above the high limit of the Control Range, the Chiller ON/OFF switch is ON, remote cycling devices are CLOSED, and system switches permit.

Normally this key is only used for servicing when the chiller is required to run, but the Daily Schedule is in an OFF period. This key avoids the need to reprogram the Daily Schedule. Once activated, Manual Override is only active for a period of 30 minutes and the following status message will be observed:

M A N U A L  
O V E R R I D E

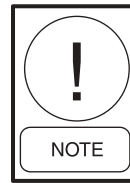

***If a Warning – Low Battery fault message appears on the display, the internal clock, calendar, and program settings cannot be relied on for accuracy. Default values are loaded into the microprocessor memory and the Manual Override key can be used to zero out the daily schedule and allow unlimited operation regardless of the time on the internal clock. Reprogramming of the setpoints and cutout values may also be necessary. When the MANUAL OVERRIDE key is pressed, the low battery message will disappear. If a power failure should again occur, the above process will again need to be repeated to bring the chiller back on line. See also Section 2.3, page 149.***

## 8. PROGRAM KEY



29023A

### 8.1 GENERAL

The Program key is used to program system operating parameters including cutout points for safeties, anticipatory unload points to avoid faults, and anti-recycle timer duration.

When the Program key is pressed, the following message will be displayed to indicate the display is in the Program Mode:

**PROGRAM MODE**

Pressing the ENTER Key causes the display to show the operator the language the control panel messages are displayed.

**DISPLAY LANGUAGE  
ENGLISH**

The operator may select 7 display message languages. The options are English, Spanish, French, Dutch, Italian, Portuguese, and Chinese. The ↑ or ↓ keys can be used to select the desired language.

Pressing the Enter key repeatedly allows scrolling through the programmable displays.

As each value is displayed, it may be reprogrammed using the 12 Entry keys and ↑↓ Keys. New values will be programmed into memory when the Enter key is pressed and the display will scroll on to the next programmable value.

If an unacceptable value is entered at any stage, the following message is displayed for a few seconds and the entered value is ignored:

**OUT OF RANGE  
TRY AGAIN!**

The following section shows examples of each programmable value display in the order in which they appear after pressing the Program key, along with guidance on programming each parameter.

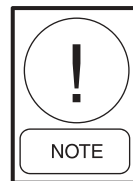

*The programmable values under the Program Key must be checked and properly programmed when commissioning the chiller. Failure to properly program these values may cause operating problems or damage to the chiller.*

### 8.2 PROGRAM KEY – USER PROGRAMMABLE VALUES

#### High Discharge Pressure Cut-Out

**DISCHARGE PRESSURE  
CUTOUT = 395.0 PSIG**

The Discharge Pressure Cutout is a microprocessor backup for the mechanical high pressure cutout located in each refrigerant circuit. This safety is bypassed for the first 5 seconds of operation after which if the cutout point is exceeded for 3 seconds, the system will shut down. Normally, air-cooled chillers, such as YCAS chillers,

should have the cutout set at 395 PSIG (27 bar) for R22 and R407C models. The micro will, however, accept values between 200 - 399 PSIG (14 - 28 bar).

To program the Discharge Pressure Cutout, key in the desired value and press the Enter key to store the value into memory and scroll to the next display.

### High Discharge Pressure Unload Point

**DISCHARGE PRESSURE  
UNLOAD = 360.0 PSIG**

The Discharge Pressure Unload point is used to avoid a high pressure cutout shutdown by unloading a compressor, if its discharge pressure approaches the cutout value. The chiller can then continue to run automatically at reduced capacity until the cause of the excessive pressure is attended to (e.g. dirty condenser coils) or ceases naturally (e.g. high ambient temperature).

For the first 60 seconds of operation, discharge pressure limiting is disabled. After this time, if discharge pressure exceeds the programmed limit, unloading of the affected compressor will occur until the discharge pressure drops below the programmed limit. The message will be removed and reloading will take place when discharge pressure has dropped to 90% of the programmed unload point.

Typically the unload point should be set 20 - 25 PSIG (1.4 - 1.7 bar) below the below the discharge pressure cutout setting. The micro will accept a range of programmable values between 200 - 399 PSIG (14 - 28 bar).

To program the Discharge Pressure Unload, key in the required setting and press the Enter key to store the value into memory and scroll to the next display.

### Low Suction Pressure Cutout

**SUCTION PRESSURE  
CUTOUT = 44.0 PSIG**

The Low Suction Pressure Cutout protects the evaporator from damage due to ice build up caused by operation at low refrigerant suction pressure.

After the compressor starts, and the pump down cycle is completed (pump down to cutout or 30 seconds, whichever comes first.), suction pressure is monitored as long as the compressor runs. For the first 270 seconds of run-

ning, suction pressure can be lower than the programmed cutout, but must be greater than:

$$\text{Programmed Cutout} \times \frac{\text{Run Time}/3 + 10}{100}$$

Example: If programmed Cutout = 44 PSIG (3 bar) and Run Time = 60 seconds

$$\text{New Cutout} = 44 \times \frac{60/3 + 10}{100} = 13.2 \text{ PSIG (0.9 bar)}$$

This cutout value increases with time, until after 270 seconds, it equals the programmed cutout value. If suction pressure falls below the calculated cutout value before 270 seconds, the system will be shut down.

After 270 seconds, a transient timer prevents short term fluctuations in suction pressure from causing shutdown as follows: If suction pressure drops below the cutout point, a 90 second transient timer starts. During the 90 second time period, the suction pressure must be greater than:

$$\text{Programmed Cutout} \times \frac{100 - \text{transient time remaining}}{100}$$

Example: If programmed Cutout = 44 PSIG (3 bar) and the timer has run 30 seconds:

$$\text{New Cutout} = 44 \text{ PSIG} \times \frac{100-60}{100} = 17.6 \text{ PSIG (1.2 bar)}$$

This cutout value increases with time, until after 90 seconds, it equals the programmed cutout value. If the suction pressure rises to more than 5 PSI (0.3 bar) above the programmed cutout value during the 90 second time period, the timer will be reset. If the suction pressure does not rise to more than 5 PSI (0.3 bar) above the cutout, the timer will remain at zero and if the pressure then falls below the cutout again, the system will shut down on a low pressure fault.

If the Dip Switch on the microprocessor board is set for "Water Cooling" (see Section 3.7), the cutout is programmable between 44 - 70 PSIG (3-5 bar) for both R22 and R-407c models. In this mode, settings of 44 PSIG (3 bar) for R22 and R-407C are recommended. If the Switch is set for "Brine Cooling" (glycol) the cutout is programmable between 5 - 70 PSIG (0.3 bar) for R22 and R-407c models. In this mode, the cutout should be set to the saturated refrigerant pressure equivalent to 18°F (10°C) below the lowest temperature of the programmed chilled liquid Control Range (Section 6).

To program the Suction Pressure Cutout, key in the required setting and press the Enter key to store the value into memory and scroll the next display.

**High Ambient Temperature Cutout**

**H I G H A M B I E N T T E M P  
C U T O U T = 1 3 0 . 0 ° F**

The High Ambient Cutout is used to select the ambient temperature above which the chiller may not operate. If the ambient temperature rises 1°F (.5°C) above this point, the chiller will shut down. Restart will occur automatically, when temperature falls more than 2°F (1°C) below the cutout and cooling demand is present.

This cutout is normally set at 130°F (54°C) to allow operation to the absolute maximum temperature capability of the electromechanical components; however, values between 100.0 - 130.0°F (38 - 54°C) are accepted.

To program the High Ambient Cutout, key in the required setting and press the Enter key to store the value into memory and scroll to the next display.

**Low Ambient Temperature Cutout**

**L O W A M B I E N T T E M P  
C U T O U T = 2 5 . 0 ° F**

The Low Ambient Cutout is used to select the ambient temperature below which the chiller may not operate. If the ambient temperature falls 1°F (.5°C) below this point, the chiller will shut down. Restart will occur automatically, when temperature rises more than 2°F (2°C) above the cutout and cooling demand is present (see also Section 2.5 page 151).

If the SW1 Dip Switch on the Microprocessor Board is set for “Standard Ambient Control” (see Section 3.7) the low ambient cutout is set at 25°F (-4°C) and is NOT programmable. If the Dip Switch is set for “Low Ambient Control”, programming of the cutout between 00.0 - 50.0°F (-17.8 - 10°C) is allowed. This allows higher values than 25°F (-4°C) to be programmed to shut down the chiller when other cooling methods become operational. Values below 25°F (-4°C) can be used for applications requiring chiller operation at lower temperatures. The chiller will not operate below 0°F (-17.8°C).

To program the Low Ambient Cutout, key in the required setting and press the Enter key to store the value into memory and scroll to the next display.

**Low Leaving Liquid Temperature CutOut**

**L E A V I N G L I Q U I D T E M P  
C U T O U T = 3 6 . 0 ° F**

The Low Leaving Liquid Temperature Cutout protects the evaporator from damage due to ice build up caused by operation below the chilled liquid freezing point.

If the leaving chilled liquid temperature (water or glycol) drops below the cutout point, the chiller will shut down. The chiller will restart automatically when temperature rises more than 4°F (2°C) above the cutout point and cooling demand exists.

If the Dip Switch on the microprocessor board is set for “Water Cooling” (see Section 3.7, page 158) the cutout is automatically set at 36°F (2°C) and cannot be reprogrammed. If the Switch is set for “Brine Cooling” (glycol) the cutout can be programmed between 08.0 - 36.0°F (-13 through -2°C). The cutout should normally be set to 4°F (2°C) below the setpoint minus the range, i.e. 34°F (setpoint) – 2°F (range) - 4°F = 28°F (see Section 6, page 170).

To program the Leaving Liquid Temperature Cutout, key in the required setting and press the Enter key to store the value into memory and scroll to the next display.

**High Motor Current Unload Point**

**H I G H M O T O R C U R R E N T  
U N L O A D = 1 0 5 % F L A**

The Motor Current Unload point is used to avoid a high motor current safety shutdown by unloading a compressor, if current draw approaches the maximum limit cutout value. The chiller can then continue to run automatically at reduced capacity until the cause of the excessive current is attended to.

The micro will accept between 30 - 105% for the unload point. The motor current safety will shut the compressor down whenever current exceeds 115%.

If the programmable limit is set between 100% and 105% of full load current, this feature will protect against excessive current causing compressor shutdown due to extremely high ambient, high chilled liquid temperature, and condenser malfunction caused by dirt or fan problems.

If the programmable limit is set below 100% of full load current, this control feature can be used for “demand limiting”. This is important when demand limiting is critical due to power requirements or limitations in the building (See also Section 1.10).

For the first 60 seconds of operation, the unloading control is disabled. After this time, if motor current exceeds the programmed limit, the SYS X CURR LIMITING message will appear on the display and a 1 second unload pulse will be sent to the slide valve of the affected compressor every 5 seconds, until the motor current drops below the programmed limit. The message will be removed and additional loading will take place when motor current drops below 90% of the programmed threshold.

**Typically, this setpoint should be set at 100% for maximum motor protection. Programming for 100% is recommended.** When programming values below 100%, the use of a leading “0” is required, e.g. 085%.

To program the High Motor Current Unload, key in the required setting and press the Enter key to store the value into memory and scroll to the next display.

### Anti-Recycle Time

```
ANTI RECYCLE TIMER
= 600 SECS
```

The Anti-Recycle Timer controls the minimum time between starts for each compressor. This is the time available for the heat build-up caused by inrush current at start to be dissipated before the next start. Insufficient cooling time between starts can cause heat build-up and motor damage. A fast compressor start response is needed in some applications and not in others. Although the minimum setting allowed on this timer will avoid excessive heat build up, adjusting the timer for the longest period acceptable in each application will reduce cycling and maximize motor life. **600 seconds is recommended.**

The micro will accept a range of programmable values between 300 - 600 seconds.

To program the Anti-Recycle Time, key in the required setting and press the Enter key to store the value into memory and scroll to the next display.

### Suction Superheat Setpoint

```
SUCTION SUPERHEAT
SETPOINT = 12.0 °F
```

The EEV superheat setpoint is programmable. The setpoint can be programmed for 9.0°F (5.0°C) to 15°F (8.3°C) with 12.0°F (6.6°C) as the default.

### Local/Remote Communications

```
LOCAL / REMOTE MODE
LOCAL
```

The panel can be programmed for “Local” or “Remote” communications. “Local” mode allows monitoring through the RS-485 port only. “Remote,” allows an external device such as an ISN or Remote Control Center to change setpoints and programming points.

The  $\uparrow\downarrow$  keys are used to change from Local to Remote. The ENTER Key must be pressed to save the selection in memory.

### Imperial/SI Units Display

```
DISPLAY UNITS
IMPERIAL
```

This allows the operator to select messages to display Imperial Units (PSIG, °F, etc.) or SI (Scientific International, Bars, °C, etc.).

The  $\uparrow\downarrow$  keys are used to change from Imperial to SI units. The ENTER Key must be pressed to save the selection in memory.

### Automatic/Manual “Lead/Lag”

```
LEAD / LAG CONTROL
AUTOMATIC
```

The chiller may be selected for manual lead/lag or automatic lead/lag. In some cases the operator may want to manually select the system that is desired to be the lead system. In most cases, automatic lead/lag is selected to allow the micro to attempt to balance run time between the system. Details of manual and automatic lead / lag operation are outlined in Section 1.21.

The  $\uparrow\downarrow$  keys are used to change from Automatic to Manual lead/lag. The ENTER key must be pressed to save the selection in memory.

If manual control is desired, press the ↑ or ↓ key. One of the following messages will be displayed:

LEAD / LAG CONTROL  
MANUAL SYS 1 LEAD

LEAD / LAG CONTROL  
MANUAL SYS 2 LEAD

System 1, 2, 3 or 4 can be selected as the lead by pressing the ↑ or ↓ key. The ENTER key must be pressed to save the selection in memory.

**Automatic/Manual Power Failure Restart**

POWER FAIL RESTART  
AUTOMATIC

The chiller may be selected for “Automatic” or “Manual” restart after a power failure. In most instances, “Automatic Restart” is preferred to allow the chiller to automatically restart when power is reapplied after a power failure. When “Manual” is selected, the chiller will not operate after re-application of power until the ON / OFF Rocker Switch on the keypad is cycled OFF and then ON.

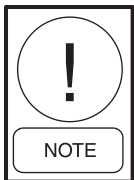

*In most applications, it is undesirable to use Manual Reset on power failure since chillers normally are required to auto-restart after a power failure.*

**8.3 PROGRAMMING "DEFAULT" VALUES**

Programmable values may be individually programmed at start-up or any time thereafter. For ease of programming, once the type of refrigerant is programmed under the Program key and in the Service Mode, a “defaults password” may be programmed to automatically program default values into memory. This will preset all programmable values under the Program key to values that will allow operation of the chiller under most operating conditions. This allows quick start-up programming for typical chilled water applications.

To program the default values into memory, first press the PROGRAM key followed by the ENTER key, to program the “refrigerant type” .

Press the Program key again, key in the numbers “6140”, then press Enter. As the code is being keyed in, the digits are not displayed but are shown as “\*” as shown:

PROGRAM MODE  
\* \* \* \*

When the Enter key is pressed, the following message will appear:

DEFAULT SETPOINTS ?  
1 = YES , 0 = NO, 1

Key in a “1” for if default setpoints are required, or a “0” for individually programmed values, then press Enter to store the selection into memory.

If individual programming is selected (0), the display will now return to the Status display. If a default setpoints have been selected, the display will momentarily display the message shown below before returning to the Status display:

PROGRAM OPTIONS SET  
TO DEFAULT VALUES



*It is often easier to select Default Setpoints and then reprogram a few that require changing rather than programming each individual value from scratch.*

The default values shown below are entered into memory, when the program option is selected. The list also provides the low and high limits the micro will accept.

**TABLE 3 – DEFAULT VALUES TABLE (MINIMUM/MAXIMUM)**

Program Value	Mode	Low Limit	High Limit	Default
Display Language	--	NA	NA	English
Discharge Pressure Cutout	--	200 PSIG	399 PSIG	399 PSIG
		13.8 Bars	27.5 Bars	27.5 Bars
Discharge Pressure Unload	--	200 PSIG	399 PSIG	375 PSIG
		13.8 Bars	27.5 Bars	25.9 Bars
Suction Pressure Cutout	Water Cooling	44.0 PSIG	70.0 PSIG	44.0 PSIG
		3.03 Bars	4.83 Bars	30.3 Bars
	Glycol Cooling	5.0 PSIG	70.0 PSIG	44.0 PSIG
		0.34 Bars	4.83 Bars	3.03 Bars
High Ambient Air Temp Cutout	--	100.0 °F	130.0 °F	130.0 °F
		37.8 °C	54.4 °C	54.4 °C
Low Ambient Air Temperature Cutout	Standard Ambient	--	--	25.0 °F
		--	--	-3.9
	Low Ambient	0 °F	50.0 °F	25.0 °F
		-17.8 °C	10.0 °C	-3.9 °C
Leaving Chilled Liquid Temp Cutout	Water Cooling	--	--	36.0
		--	--	2.2
	Glycol Cooling	8.0 °F	36.0 °F	36.0 °F
		-13.3 °C	2.2 °C	2.2 °C
	Low Temp Glycol	-5.0 °F	36.0 °F	36.0 °F
		-20.5 °C	2.2 °C	2.2 °C
High Motor Current Unload	--	30%	105%	100
Anti Recycle Time	--	300 sec	600 sec	600 sec
Local / Remote Mode	--	NA	NA	Local
Units Mode	--	NA	NA	Imperial
Lead / Lag Control Mode	--	NA	NA	Automatic
Power Failure Restart Mode	--	NA	NA	Automatic
Motor Current Averaging Cutout	--	30% FLA	110% FLA	70 % FLA
Suction Superheat Setpoint	EEV	9.0 °F	15.0 °F	12.0 °F
		5.0 °C	8.3 °C	6.6 °C

## 8.4 ELECTRONIC EXPANSION VALVE

### ELECTRONIC EXPANSION VALVE

The Electronic Expansion Valve (EEV) is an electronically controlled expansion valve. The control algorithms to control the EEV reside in the microprocessor software. The superheat setpoint can be programmed on the control panel.

The purpose of the EEV is to meter a flow of liquid refrigerant into the evaporator to maintain a superheat

setpoint. The refrigerant flow direction is designated by an arrow on the expansion valve body.

There are two safeties associated with the EEV; Low Superheat Cutout and Sensor Failure Cutout.

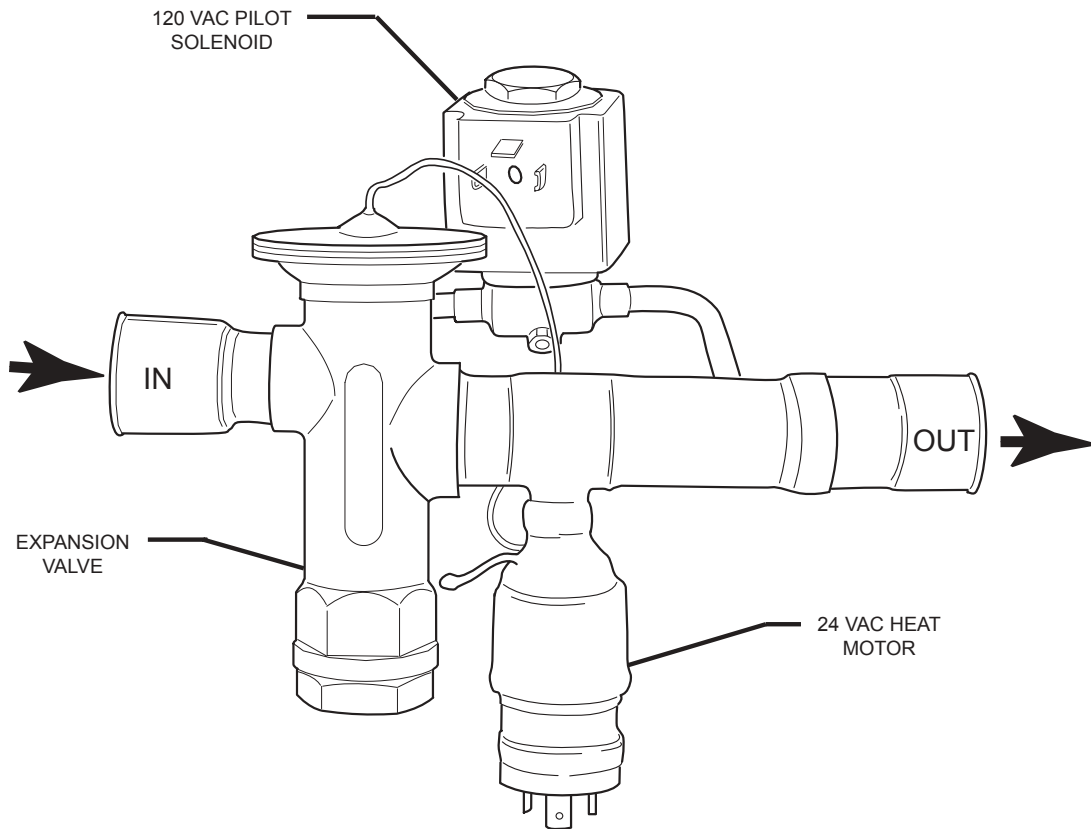

FIG. 78 – ELECTRONIC EXPANSION VALVE

LD09132

## 8.5 EEV OPERATION

### EEV OPERATION

The EEV is an electronically controlled expansion valve that meters a flow of liquid refrigerant into the evaporator to control superheat. The refrigerant flow direction is designated by an arrow on the expansion valve body.

### 24VAC HEAT MOTOR

The 24VAC Heat Motor is fed from the EEV output board in the control panel. The Heat Motor allows the micro to open and close the valve to control suction superheat.



*The heat motor must be plugged into the 24 volt shielded cable feed from the EEV output board. Damage to the heat motor will occur if it is plugged into 120VAC wiring for the Pilot Solenoid.*

### CONTROLLER

When EEV is selected as the expansion valve type via DIP switch on the micro board, the EEV controller will become active. When TXV is selected, the EEV output will be fixed at 0 and the low superheat and sensor failure safeties will be disabled.

The EEV controller is a PI (Proportional plus Integral) controller. Gain scheduling varies the proportional gain based on the superheat error. As the superheat error gets smaller the proportional gain will get smaller. The integration time is adjusted to increase the controller response during start-up and low superheat conditions.

The output from the PI controller is the EEV output percentage which is shown on the display and printouts. This output is then fed into a model of the ETRE bulb/heat motor to over and under drive the heat motor for faster valve response. The output of this ETRE model is the PWM percentage that will be sent to the ETRE heat motor. This PWM output is the percentage of a 1 second period that the 24VAC heat motor power signal is energized.

### MOP FEATURE

The controller also has an MOP feature (Maximum Operating Pressure) that overrides superheat control when the MOP setpoint is exceeded. This control generally will be active for hot water starts. The MOP setpoint is 60° F Saturated Suction Temperature.

The MOP feature is also used to prevent undershoot of the superheat setpoint when the suction temperature of a system being started is much higher than the return water temperature. This provides better startup superheat control for high ambient, low water temp startups when the superheat measurement is artificially high due to the warm suction line. If the return water temp sensor is in range, run time is less than 5 minutes, and suction temperature is greater than (RCHLT + 3° F), the MOP setpoint is reset to RCHLT - Superheat Setpoint. If this value is higher than the fixed MOP setpoint, the original setpoint is retained.

### VALVE PREHEAT FEATURE

The heat motor is preheated for moderate and low ambient standby conditions. When the ambient is below 25° F, the heat motor is preheated with a 25% duty cycle. This preheated value is ramped from 25% to 0% from 25° F to 50° F. When the ambient is above 50° F the heat motor is not preheated.

### PILOT SOLENOID (LLSV) CONTROL

The Pilot Solenoid allows the EEV to be used in the same way as a Liquid Line Solenoid Valve. When the Pilot Solenoid is turned off, the EEV closes immediately and prevents the Heat Motor from opening the valve.

Each system has a Pump Down feature upon shut off. Manual pump down from the keypad is not possible. On a non-safety, non-unit switch shutdown, the system will fully unload. The Pilot Solenoid will be turned off and the system will run unloaded until the suction pressure falls below the cutout or for 180 seconds, whichever comes first.

The Pilot Solenoid is also used as a low superheat safety device when EEV is selected as the expansion valve type, for YCAL units only. While the system is running and not in a pumpdown mode the Pilot Solenoid will close if the suction superheat falls below 4.0°F (2.2°C). The Pilot Solenoid will open again when the superheat rises above 7.0°F (3.9°C). This safety device is ignored for the first 30 seconds of system run time. If the Pilot Solenoid is closed 10 times in 2 minutes on the safety device, the low superheat safety will be triggered.

**LOW SUPERHEAT CUTOUT SAFETY**

The Low Superheat Cutout is to protect the compressors from liquid floodback due to low suction superheat. This safety is only active when EEV is selected as the expansion valve type. This safety is ignored for the first 30 seconds of system run time.

This safety can be triggered by two events. The first is when the suction superheat is less than 2.0°F (1.1°C) for 3 seconds. The second, only applies to YCAL units, is when the Pilot Solenoid is closed 10 times in 2 minutes due to low superheat. Following are the safety fault messages for all systems:

```
SYS 1 LOW SUPERHEAT
SYS 2 LOW SUPERHEAT
```

**SENSOR FAILURE CUTOUT SAFETY**

The Sensor Failure Cutout is to prevent the EEV from running when the sensors measuring superheat are not functioning properly. This safety is only active when EEV is selected as the expansion valve type. This safety is ignored for the first 15 seconds of system run time.

This safety will shutdown a system if either suction temperature or suction pressure sensors read out of range high or low. This condition must be present for 3 seconds to cause a system shutdown. This safety will lock out a system the first time and will not allow automatic restarting. Following are the messages for all systems:

```
SYS 1 SENSOR FAILURE
SYS 2 SENSOR FAILURE
```

**OPERATING DATA DISPLAYS**

The following display relating to EEV operation is available under each systems Data Key: EEV Output% and Suction Superheat.

```
SYS X EEV = XXX.X %
SUCTION SHEAT = XXX.X °F
```

**HISTORY DATA DISPLAYS**

The following display relating to EEV operation is available under each systems Data Key: EEV Output% and Suction Superheat.

```
SYS X EEV = XXX.X %
SUCTION SHEAT = XXX.X °F
```

**OPERATING DATA PRINTOUT**

Pressing the PRINT key and then the OPER DATA key allows the operator to obtain a printout of current system operating parameters. When the OPER DATA key is pressed, a snapshot will be taken of system operating conditions and panel programming selections. This data will be temporarily stored in memory and transmission of this data will begin to the printer. The following items are added to the standard operational data printout when EEV is selected:

SYSTEM 1 DATA	
COMPRESSORS STATUS	OFF
RUN TIME	0- 0- 0- 0 D-H-M-S
MOTOR CURRENT	0 AMPS 0 %FLA
SUCTION PRESSURE	125 PSIG
DISCHARGE PRESSURE	131 PSIG
OIL PRESSURE	130 PSIG
FAN DISCHARGE PRESS	254 PSIG(B HR)
SUCTION TEMPERATURE	68.4 DEGF
DISCHARGE TEMPERATURE	68.8 DEGF
OIL TEMPERATURE	68.8 DEGF
SAT SUCTION TEMP	71.8 DEGF
SUCTION SUPERHEAT	3.4 DEGF
SAT DISCHARGE TEMP	74.5 DEGF
DISCHARGE SUPERHEAT	6.3 DEGF
SLIDE VALVE STEP	0
<b>EEV OUTPUT</b>	<b>0.0 %(EEV)</b>
COOLER INLET REFRIG	44.6 DEGF
LIQUID LINE SOLENOID	OFF
ECONOMIZER TXV SOLENOID	OFF(YCAS)
OIL COOLING SOLENOID	OFF(YCWS)
HEAT RECOVERY SOLENOID	OFF(B HR)
DISCHARGE COOLING SOLENOID	OFF(EC,LT)
CONDENSER FAN STAGE	OFF
COMPRESSOR HEATER	ON
WYE-DELTA RELAY	OFF

## 8.6 EEV PROGRAMMING

### EXPANSION VALVE OPTIONS DISPLAY

When the expansion valve type is set to thermostatic by opening DIP switch #7, the EEV controller, low superheat safety device, low superheat safety and the sensor failure safety will be disabled. The EEV output will be set to 0.

S1 - 7    E X P A N S I O N   V A L V E  
T H E R M O S T A T I C

When the expansion valve type is set to electronic by closing DIP switch #7, the EEV controller, low superheat safety device, low superheat safety and the sensor failure safety will be enabled.

S1 - 7    E X P A N S I O N   V A L V E  
T H E R M O S T A T I C

The Expansion Valve type selection is viewable under the OPTIONS key.

### PROGRAM MODE DISPLAYS

The following value is programmable under the PROGRAM key (See Table 4).

- System Suction Superheat Setpoint (9.0°F to 15.0°F)  
(5.0°C to 8.3°C)

S U C T   S U P E R H E A T  
S E T P O I N T   =   X X . X ° F

**TABLE 4 – PROGRAMMABLE VALUES TABLE (MINIMUM/MAXIMUM)**

PROGRAM VALUE	MODE	LOW LIMIT	HIGH LIMIT	DEFAULT
SUPERHEAT SETPOINT	EEV	9.0°F (5.0°C)	15.0°F (8.3°C)	12.0°F (6.6°C)

## 8.7 EEV TROUBLESHOOTING

### TROUBLESHOOTING

Below are problems and possible solutions or items to check.

#### • The system shuts down on Low Suction Pressure

- Verify that all refrigerant valves are open.
- Verify that the system is not low on charge.
- Verify that the Expansion Valve Type is set to Electronic.
- Verify that the pilot solenoid is energizing (use Service Mode to manually energize the solenoid coil).
- Verify that the EEV is wired per the elementary diagram.
- Verify that the Heat Motor is getting a 24VAC PWM signal. (Use Service Mode to manually energize the EEV output.
- If everything checks out, it is possible that the EEV has failed. If the small charge in the bulb leaks, the valve will not be able to open and the entire EEV must be replaced.

#### • The system shuts down on Low Superheat

- Verify that the suction temperature sensors are properly installed. They should be located at 4 or 8 o'clock on the suction line. They should not be located near the outlet of the evaporator. They should be installed with copper straps and be well insulated.
- Verify that the suction temperature sensor cables are not swapped between systems (unplugging one sensor at a time with the chiller off can verify proper wiring).
- Verify that the EEV heat motor is properly insulated.
- For units with Hot Gas Bypass installed, check that the Hot Gas Bypass valve is set correctly.
- For glycol units, verify that the glycol % is correct.

### 8.8 3 COMPRESSOR CONDENSER FAN CONTROL

The chiller is equipped with 12 or 14 condenser fans, with 4 or 5 fans per system as given below. Fan control is via Outside Ambient Temperature (OAT) and Discharge Pressure (DP). There are six stages of fan control utilizing 3 outputs per system. The fan stages will operate according to Table 5 or Table 6 depending on the number of fans/system. There will be a minimum 5 second delay between all fan stages.

Condenser fan ON conditions are governed solely by the Discharge Pressure (DP). When the DP rises above 220 PSIG, fan stage 1 is activated. From here, subsequent fan stages are activated as the DP rises in increments of 15 PSIG, except stage 6, which is activated when the DP rises over 290 PSIG. The system will remain at the

highest fan stage reached unless the OFF conditions given in the next paragraph are satisfied.

Condenser fan OFF conditions are governed by both the DP and OAT. Fan staging will be decreased from the highest stage reached if both the DP and OAT requirements are met. For example, if a system is at a fan stage of 4, and the DP falls under 195 PSIG and the OAT drops below 75°F, the fan stage will be reduced to 3. The ON/OFF conditions are provided in the next two tables.

The tables below also indicate fan contactors, wire numbers, and Relay Output Board or I/O Expansion Board Output numbers relating to fans energized. SYS 1 fan contactors are controlled by Relay Output Board # 1. SYS 2 by Relay Output Board # 2. SYS 3 is controlled by I/O Expansion Board #2.

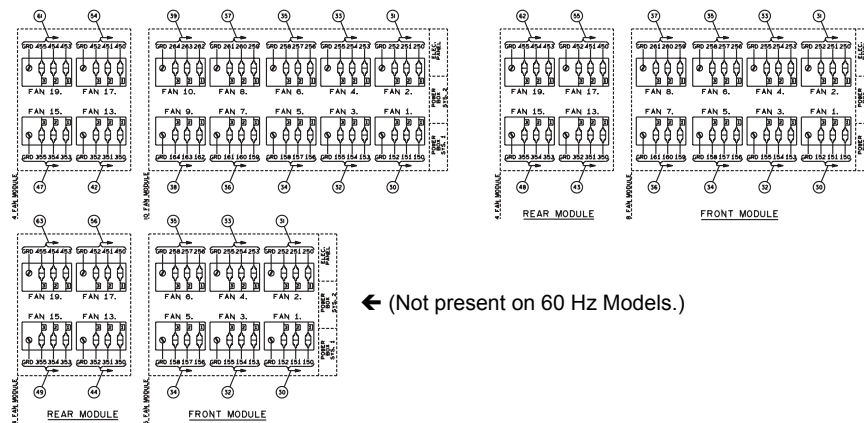

FIG. 79 – CONDENSER FAN CONTROL LAYOUT FOR DXST COMPRESSORS UNITS

TABLE 5 – CONDENSER FAN CONTROL AND FAN CONTACTOR DATA FOR DXST UNITS WITH 4 FANS/SYSTEM

	Fan Stage	Fans	ON * Conditions DP	OFF Conditions DP & OAT	Fan Contactor	Wire Number	Relay Board Output
SYS 1	1	1	>230 PSIG	<160 PSIG & <60°F	9M	130	15
	2	3	>240 PSIG	<180 PSIG & <65°F	10M	131	14
	3	5, 7	>265 PSIG	<195 PSIG & <70°F	11M, 12M	132	10
	4	1, 5, 7	>275 PSIG	<205 PSIG & <75°F	9M, 11M, 12M	130, 132	10, 15
	5	3, 5, 7	>285 PSIG	<210 PSIG & <80°F	10M, 11M, 12M	131, 132	10, 14
	6	1, 3, 5, 7	>295 PSIG	<215 PSIG & <85°F	9M, 10M, 11M, 12M	130, 131, 132	10, 14, 15
SYS 2	1	2	>230 PSIG	<160 PSIG & <60°F	15M	230	15
	2	4	>240 PSIG	<180 PSIG & <65°F	16M	231	14
	3	6, 8	>265 PSIG	<195 PSIG & <70°F	17M, 18M	232	10
	4	2, 6, 8	>275 PSIG	<205 PSIG & <75°F	15M, 17M, 18M	230, 232	10, 15
	5	4, 6, 8	>285 PSIG	<210 PSIG & <80°F	16M, 17M, 18M	231, 232	10, 14
	6	2, 4, 6, 8	>295 PSIG	<215 PSIG & <85°F	15M, 16M, 17M, 18M	230, 231, 232	10, 14, 15
SYS 3	Fan Stage	Fans	ON * Conditions DP	OFF * Conditions DP & OAT	Fan Contactor	Wire Number	I/O Expansion Board Output TB3
	1	13	>230 PSIG	<160 PSIG & <60°F	21M	330	8
	2	15	>240 PSIG	<180 PSIG & <65°F	22M	331	9
	3	17, 19	>265 PSIG	<195 PSIG & <70°F	23M, 24M	332	10
	4	13, 17, 19	>275 PSIG	<205 PSIG & <75°F	21M, 23M, 24M	330, 332	8, 10
	5	15, 17, 19	>285 PSIG	<210 PSIG & <80°F	22M, 23M, 24M	331, 332	9, 10
6	13, 15, 17, 19	>295 PSIG	<215 PSIG & <85°F	21M, 22M, 23M, 24M	330, 331, 332	8, 9, 10	

\* At ambients above 85°F, stages 3, 4, 5, and 6 will all turn on at 240 psig.

**TABLE 6 – CONDENSER FAN CONTROL AND FAN CONTACTOR DATA FOR DXST UNITS WITH 5 FANS/SYSTEM**

	Fan Stage	Fans	ON * Conditions DP	OFF Conditions DP & OAT	Fan Contactor	Wire Number	Relay Board Output
<b>S Y S 1</b>	1	1	>230 PSIG	<160 PSIG & <60°F	9M	130	15
	2	3, 5	>240 PSIG	<180 PSIG & <65°F	10M, 11M	131	14
	3	7, 9	>265 PSIG	<195 PSIG & <70°F	12M, 13M	132	10
	4	1, 7, 9	>275 PSIG	<205 PSIG & <75°F	9M, 12M, 13M	130, 132	10, 15
	5	3, 5, 7,9	>285 PSIG	<210 PSIG & <80°F	10M, 11M, 12M, 13M	131, 132	10, 14
	6	1, 3, 5, 7,9	>295 PSIG	<215 PSIG & <85°F	9M, 10M, 11M, 12M, 13M	130, 131, 132	10, 14, 15
<b>S Y S 2</b>	1	2	>230 PSIG	<160 PSIG & <60°F	15M	230	15
	2	4,6	>240 PSIG	<180 PSIG & <65°F	16M, 17M	231	14
	3	8, 10	>265 PSIG	<195 PSIG & <70°F	18M, 19M	232	10
	4	2, 8, 10	>275 PSIG	<205 PSIG & <75°F	15M, 18M, 19M	230, 232	10, 15
	5	4, 6, 8,10	>285 PSIG	<210 PSIG & <80°F	16M, 17M, 18M, 19M	231, 232	10, 14
	6	2, 4, 6, 8, 10	>295 PSIG	<215 PSIG & <85°F	15M, 16M, 17M, 18M, 19M	230, 231, 232	10, 14, 15
<b>S Y S 3</b>	<b>SYSTEM 3 IS ALWAYS EQUIPPED WITH 4 FANS.</b>						

\* At ambients above 85°F, stages 3, 4, 5, and 6 will all turn on at 240 psig.

### 8.9 4 COMPRESSOR CONDENSER FAN CONTROL

The chiller is equipped with 14 or 18 condenser fans, with 3, 4 or 5 fans per system as given below. Fan control is via Outside Ambient Temperature (OAT) and Discharge Pressure (DP). There are six stages of fan control utilizing 3 outputs per system. The fan stages will work according to Table 7 or Table 8 depending on the number of fans/system. There will be a minimum 5 second delay between all fan stages.

Condenser fan ON conditions are governed solely by the Discharge Pressure (DP). When the DP rises above 220 PSIG, fan stage 1 is activated. From here, subsequent fan stages are activated as the DP rises in increments of 15 PSIG, except stage 6, which is activated when the DP rises over 290 PSIG. The system will remain at the

highest fan stage reached unless the OFF conditions given in the next paragraph are satisfied.

Condenser fan OFF conditions are governed by both the DP and OAT. Fan staging will be decreased from the highest stage reached if both the DP and OAT requirements are met. For example, if a system is at a fan stage of 4, and the DP falls under 195 PSIG and the OAT drops below 75°F, the fan stage will be reduced to 3. The ON/OFF conditions are provided in the next two tables.

The tables below also indicate fan contactors, wire numbers, and Relay Output Board or I/O Expansion Board Output numbers relating to fans energized. SYS 1 fan contactors are controlled by Relay Output Board # 1. SYS 2 by Relay Output Board # 2. SYS 3 and 4 are controlled by I/O Expansion Board #2.

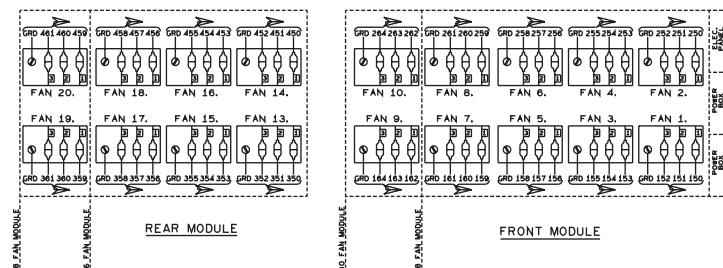

FIG. 80 – CONDENSER FAN CONTROL LAYOUT FOR DXST COMPRESSORS UNITS

LD05023

TABLE 7 – CONDENSER FAN CONTROL AND FAN CONTACTOR DATA FOR DXST UNITS WITH 4 FANS/SYSTEM

	Fan Stage	Fans	ON * Conditions DP	OFF Conditions DP & OAT	Fan Contactor	Wire Number	Relay Board Output
SYS 1	1	1	>230 PSIG	<160 PSIG & <60°F	9M	130	15
	2	3	>240 PSIG	<180 PSIG & <65°F	10M	131	14
	3	5, 7	>265 PSIG	<195 PSIG & <70°F	11M, 12M	132	10
	4	1, 5, 7	>275 PSIG	<205 PSIG & <75°F	9M, 11M, 12M	130, 132	10, 15
	5	3, 5, 7	>285 PSIG	<210 PSIG & <80°F	10M, 11M, 12M	131, 132	10, 14
	6	1, 3, 5, 7	>295 PSIG	<215 PSIG & <85°F	9M, 10M, 11M, 12M	130, 131, 132	10, 14, 15
SYS 2	1	2	>230 PSIG	<160 PSIG & <60°F	15M	230	15
	2	4	>240 PSIG	<180 PSIG & <65°F	16M	231	14
	3	6, 8	>265 PSIG	<195 PSIG & <70°F	17M, 18M	232	10
	4	2, 6, 8	>275 PSIG	<205 PSIG & <75°F	15M, 17M, 18M	230, 232	10, 15
	5	4, 6, 8	>285 PSIG	<210 PSIG & <80°F	16M, 17M, 18M	231, 232	10, 14
	6	2, 4, 6, 8	>295 PSIG	<215 PSIG & <85°F	15M, 16M, 17M, 18M	230, 231, 232	10, 14, 15
	Fan Stage	Fans	ON * Conditions DP	OFF * Conditions DP & OAT	Fan Contactor	Wire Number	I/O Expansion Board Output (TB3 SYS) (TB4 SYS)
SYS 3	1	13	>230 PSIG	<160 PSIG & <60°F	21M	330	8
	2	15	>240 PSIG	<180 PSIG & <65°F	22M	331	9
	3	17, 19	>265 PSIG	<195 PSIG & <70°F	23M, 24M	332	10
	4	13, 17, 19	>275 PSIG	<205 PSIG & <75°F	21M, 23M, 24M	330, 332	8, 10
	5	15, 17, 19	>285 PSIG	<210 PSIG & <80°F	22M, 23M, 24M	331, 332	9, 10
	6	13, 15, 17, 19	>295 PSIG	<215 PSIG & <85°F	21M, 22M, 23M, 24M	330, 331, 332	8, 9, 10
SYS 4	1	14	>230 PSIG	<160 PSIG & <60°F	27M	430	8
	2	16	>240 PSIG	<180 PSIG & <65°F	28M	431	9
	3	18, 20	>265 PSIG	<195 PSIG & <70°F	29M, 30M	432	10
	4	14, 18, 20	>275 PSIG	<205 PSIG & <75°F	27M, 29M, 30M	430, 432	8, 10
	5	16, 18, 20	>285 PSIG	<210 PSIG & <80°F	28M, 29M, 30M	431, 432	9, 10
	6	14, 16, 18, 20	>295 PSIG	<215 PSIG & <85°F	27M, 28M, 29M, 30M	430, 431, 432	8, 9, 10

\* At ambients above 85°F, stages 3, 4, 5, and 6 will all turn on at 240 psig.

**TABLE 8 – CONDENSER FAN CONTROL AND FAN CONTACTOR DATA FOR DXST UNITS WITH 5 FANS/SYSTEM**

	Fan Stage	Fans	ON * Conditions DP	OFF Conditions DP & OAT	Fan Contactor	Wire Number	Relay Board Output
<b>S Y S 1</b>	1	1	>230 PSIG	<160 PSIG & <60°F	9M	130	15
	2	3, 5	>240 PSIG	<180 PSIG & <65°F	10M, 11M	131	14
	3	7, 9	>265 PSIG	<195 PSIG & <70°F	12M, 13M	132	10
	4	1, 7, 9	>275 PSIG	<205 PSIG & <75°F	9M, 12M, 13M	130, 132	10, 15
	5	3, 5, 7, 9	>285 PSIG	<210 PSIG & <80°F	10M, 11M, 12M, 13M	131, 132	10, 14
	6	1, 3, 5, 7, 9	>295 PSIG	<215 PSIG & <85°F	9M, 10M, 11M, 12M	130, 131, 132	10, 14, 15
<b>S Y S 2</b>	1	2	>230 PSIG	<160 PSIG & <60°F	15M	230	15
	2	4,6	>240 PSIG	<180 PSIG & <65°F	16M, 17M	231	14
	3	8, 10	>265 PSIG	<195 PSIG & <70°F	18M, 19M	232	10
	4	2, 8, 10	>275 PSIG	<205 PSIG & <75°F	15M, 18M, 19M	230, 232	10, 15
	5	4, 6, 8,10	>285 PSIG	<210 PSIG & <80°F	16M, 17M, 18M, 19M	231, 232	10, 14
	6	2, 4, 6, 8, 10	>295 PSIG	<215 PSIG & <85°F	15M, 16M, 17M, 18M, 19M	230, 231, 232	10, 14, 15
<b>S Y S 3</b>	<b>SYSTEM 3 IS ALWAYS EQUIPPED WITH 3 OR 4 FANS.</b>						
<b>S Y S 4</b>	<b>SYSTEM 4 IS ALWAYS EQUIPPED WITH 3 OR 4 FANS.</b>						

\* At ambients above 85°F, stages 3, 4, 5, and 6 will all turn on at 240 psig.

**TABLE 9 – CONDENSER FAN CONTROL AND FAN CONTACTOR DATA FOR DXST UNITS WITH 3 FANS/SYSTEM**

	Fan Stage	Fans	ON * Conditions DP	OFF Conditions DP & OAT	Fan Contactor	Wire Number	I/O Expansion Board Output (TB3 SYS) (TB4 SYS)
<b>S Y S 1</b>	<b>SYSTEM 1 IS ALWAYS EQUIPPED WITH 4 OR 5 FANS.</b>						
<b>S Y S 2</b>	<b>SYSTEM 2 IS ALWAYS EQUIPPED WITH 4 OR 5 FANS.</b>						
<b>S Y S 3</b>	1	13	>230 PSIG	<160 PSIG & <60°F	21M	330	8
	2	15	>240 PSIG	<180 PSIG & <65°F	22M	331	9
	3	17	>265 PSIG	<185 PSIG & <70°F	23M	332	10
	4	13, 17	>275 PSIG	<205 PSIG & <75°F	21M, 23M	330, 332	8, 10
	5	15, 17	>285 PSIG	<210 PSIG & <80°F	22M, 23M	331, 332	9, 10
	6	13, 15, 17	>295 PSIG	<215 PSIG & <85°F	21M, 22M, 23M	330, 331, 332	8, 9, 10
<b>S Y S 4</b>	1	14	>230 PSIG	<160 PSIG & <60°F	27M	430	8
	2	16	>240 PSIG	<180 PSIG & <65°F	28M	431	9
	3	18	>265 PSIG	<195 PSIG & <70°F	29M	432	10
	4	14, 18	>275 PSIG	<205 PSIG & <75°F	27M, 29M	430, 432	8, 10
	5	16, 18	>285 PSIG	<210 PSIG & <80°F	28M, 29M	431, 432	9, 10
	6	14, 16, 18	>295 PSIG	<215 PSIG & <85°F	27M, 28M, 29M	430, 431, 432	8, 9, 10

\* At ambients above 85°F, stages 3, 4, 5, and 6 will all turn on at 240 psig.

## 8.10 SERVICE MODE: UNIT SETUP

The Service Mode allows programming unit set-up values. These values are programmed before the chiller leaves the factory and typically should never be changed.



***Catastrophic failure of chiller components can occur if the set-up values are improperly programmed. If for some reason these values need to be checked or changed, care should be exercised.***

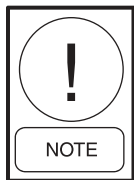

***Whenever an EPROM is changed, the programmed values should be recorded prior to removing the old EPROM. These values should then be checked and programmed into the micro when the new EPROM is installed.***

Setup values may be checked in the Service Mode by pressing the PROGRAM, 5144, and ENTER keys. Table 10 lists the value and the program range that will be accepted.

SETUP MODE VALUE	PROGRAMMABLE RANGE
Refrigerant Type	R-22 or R-407C
R-407C Chiller Type	Optimized or Drop-in
Unit Type	YCAS or YCWS **
Heat Recovery Unit	Enabled or Disabled ***
Sys 1 100% Full Load Amps	75 to 500 Amps *
Sys 2 100% Full Load Amps	75 to 500 Amps *
Sys 1 Motor Protector Input	1.0 to 5.0 volts *
Sys 2 Motor Protector Input	1.0 to 5.0 volts *
Oil Cooling On	167 to 203 °F 180 °F default ****
Oil Cooling Diff	9 to 18 °F 9 °F default ****
Discharge Cooling On	176.0 to 239.0 °F 212.0 °F default
Discharge Cooling Diff	7.2 to 27.0 °F 18 °F default
Data Logging Mode	OFF or ON

Data Logging Timer	6 to 60 seconds
Sys 1 Operating Hours	0 to 99,999
Sys 2 Operating Hours	0 to 99,999
Sys 1 Starts	0 to 99,999
Sys 2 Starts	0 to 99,999
Clear History Buffer	YES or NO

**TABLE 10 – SERVICE MODE PROGRAMMABLE VALUES**

### NOTE:

- \* See the Table for programming system 100% Full Load Amps and System Motor Protector input voltage. Also assure that the correct number of wires per phase pass through each C.T. The C.T. is built internally into the 2ACE motor protector.
- \*\* The chiller must always be programmed for YCAS
- \*\*\* Heat recovery must always be disabled.
- \*\*\*\* Oil and discharge cooling is only utilized on special low temp chiller.

**TABLE 11 – YCAS STYLE G, ACROSS THE LINE START - 50 HZ.**

<b>Model No.</b>	<b>Volt. Code</b>	<b>Chiller Name-Plate RLA</b>	<b>No. Leads per Phase</b>	<b>100% FLA Of Sys.</b>	<b>MP OL Value Set</b>
0693 Sys 1 & 2	50	140	2	151	189
693 Sys 3	50	124	2	134	167
0773 Sys 1 & 2	50	140	2	151	189
0773 Sys 3	50	183	*2	198	124
0783 Sys 1 & 2	50	124	2	134	167
0783 Sys 3	50	168	*2	181	113
0873	50	168	*2	181	113
0953	50	183	*2	198	124
1063 Sys 1 & 2	50	161	2	174	217
1063 Sys 3 & 4	50	140	2	151	189
1093 Sys 1 & 2	50	183	*2	198	124
1093 Sys 3 & 4	50	140	2	151	189
1163	50	168	*2	181	113
1263	50	183	*2	198	124

\* Indicates one lead/phase through motor protector.

**TABLE 12 – YCAS STYLE G, WYE DELTA START - 50 HZ.**

Model No.	Volt. Code	Chiller Name - Plate RLA	No. Leads per Phase	100% FLA Of Sys.	MP OL Value Set
0693 Sys 1 & 2	50	140	2	151	189
693 Sys 3	50	124	2	134	167
0773 Sys 1 & 2	50	140	2	151	189
0773 Sys 3	50	183	*2	198	143
0783 Sys 1 & 2	50	124	2	134	167
0783 Sys 3	50	168	*2	181	132
0873	50	168	*2	181	132
0953	50	183	*2	198	143
1063 Sys 1 & 2	50	161	2	174	217
1063 Sys 3 & 4	50	140	2	151	189
1093 Sys 1 & 2	50	183	*2	198	143
1093 Sys 3 & 4	50	140	2	151	189
1163	50	168	*2	181	132
1263	50	183	*2	198	143

\* Indicates one lead/phase through motor protector.

**SERVICE MODE: VIEWING INPUTS AND OUTPUTS**

All digital and analog inputs and digital outputs can be viewed by pressing the FUNCTION key and the pressing of the OPER DATA key. The UP and DOWN arrow keys can then be used to scroll through the inputs and outputs.

Each analog input will display the name of the measured value, the input plug/pin number on the microboard, the voltage read on the input, and the voltage converted to pressure or temperature. An example is shown below:

```
SYS 1 SUCT PR J13-7
X.X VDC = XXXX PSIG
```

Each digital input will display the name of the measured value, the input plug/pin number on the micro board, and the state of the input (ON or OFF). An example is shown below:

```
SYS 1 RUN PERM
J4-5 IS OFF
```

Each digital output will display the name of the item controlled by the output, the output plug/pin number on the microboard and the state of the output (ON and OFF). An example is shown below:

```
SYS 1 LLSV
J7-3 IS OFF
```

**SERVICE MODE: OUTPUT ENABLE**

The Service Mode allows the user to enable and disable the outputs (except compressor). To enter the Service Mode, turn the UNIT switch off and press PROGRAM, 9675, ENTER. A message will be displayed for 2 seconds indicating that the service mode has been enabled. Service Mode will time out after 60 minutes and return to the normal mode. Service mode can also be disabled by turning the UNIT switch on or by powering the 115 VAC off and on.

Once Service Mode is entered, all of the outputs will be turned off. The outputs can be turned on by pressing.

FUNCTION and then the OPER DATA key and scrolling past the input displays to the output displays. The arrow keys are used to scroll forward and backwards in the displays, while the ENTER key is used to toggle the outputs on and off. Only one output will be allowed on at a time. The only exception will be the compressors which cannot be turned on and off in this mode.

## 8.11 CONTROL INPUTS/OUTPUTS

Tables 13 through 16 are a quick reference list providing the connection points and a description of the inputs and outputs respectively. All input and output connections pertain to the connections at the microboard, relay, or I/O Board.

### DIGITAL OUTPUTS

**TABLE 13 - DIGITAL OUTPUTS**

Microboard / Relay Board 1	J7-1 / TB1-20	Sys 1 Compressor
Microboard / Relay Board 1	J7-2 / TB1-19	Sys 1 Compressor Heater
Microboard / Relay Board 1	J7-3 / TB1-18	Sys 1 Liquid Line Solenoid Valve
Microboard / Relay Board 1	J7-4 / TB1-17/16	SPARE
Microboard / Relay Board 1	J7-5 / TB1-15	Sys 1 Condenser Fans Output 1
Microboard / Relay Board 1	J7-6 / TB1-14	Sys 1 Condenser Fans Output 2
Microboard / Relay Board 1	J9-1 / TB1-10	Sys 1 Condenser Fans Output 3
Microboard / Relay Board 1	J9-2 / TB1-9	Sys 1 Economizer TXV Solenoid
Microboard / Relay Board 1	J9-3 / TB1-8	Sys 1 Wye Delta Relay
Microboard / Relay Board 1	J9-4 / TB1-7	SPARE
Microboard / Relay Board 1	J9-5 / TB1-6/5	Evaporator Heater
Microboard / Relay Board 1	J9-6 / TB1-4/3	Sys 1 Alarm
Microboard / Relay Board 2	J10 / TB1-20	Sys 2 Compressor
Microboard / Relay Board 2	J10-2 / TB1-19	Sys 2 Compressor Heater
Microboard / Relay Board 2	J10-3 / TB1-18	Sys 2 Liquid Line Solenoid Valve
Microboard / Relay Board 2	J10-4 / TB1-17/16	Chiller Run
Microboard / Relay Board 2	J10-5 / TB1-15	Sys 2 Condenser Fans Output 1
Microboard / Relay Board 2	J10-6 / TB1-14	Sys 2 Condenser Fans Output 2
Microboard / Relay Board 2	J8-1 / TB1-10	Sys 2 Condenser Fans Output 3
Microboard / Relay Board 2	J8-2 / TB1-9	Sys 2 Economizer TXV Solenoid
Microboard / Relay Board 2	J8-3 / TB1-8	Sys 2 Wye Delta Relay
Microboard / Relay Board 2	J8-4 / TB1-7	SPARE
Microboard / Relay Board 2	J8-5 / TB1-6/5	Evaporator Pump
Microboard / Relay Board 2	J8-6 / TB1-4/3	Sys 2 Alarm
I/O Expansion	J13-1	Sys 1 EEV Heat Motor
I/O Expansion	J13-2	Sys 2 EEV Heat Motor

**ANALOG INPUTS**

Not all of the sensors are installed in every unit as some of them are optional. However, the software must still be able to read the sensors if the optional ones are installed. Table 14 lists all of the analog inputs and whether they are on the Microboard or the I/O Expansion Board.

**TABLE 14 - ANALOG INPUTS**

Microboard	J11-7	Leaving Chilled Liquid Temp Sensor
Microboard	J11-8	Return Chilled Liquid Temp Sensor
Microboard	J11-9	Ambient Air Temp Sensor
Microboard	J12-1	SPARE
Microboard	J12-3	SPARE
Microboard	J13-7	Sys 1 Suction Pressure Transducer
Microboard	J13-8	Sys 1 Oil Pressure Transducer
Microboard	J14-7	Sys 2 Suction Pressure Transducer
Microboard	J14-8	Sys 2 Oil Pressure Transducer
Microboard	J15-7	Sys 2 Discharge Pressure Transducer
Microboard	J15-8	Sys 1 Discharge Pressure Transducer
Microboard	J16-4	Sys 2 Suction Temp Sensor
Microboard	J16-6	Sys 1 Suction Temp Sensor
Microboard	J17-9	Input from I/O Expansion Board
Microboard	J17-10	SPARE
Microboard	J17-11	Mixed Chilled Liquid Temp Sensor (optional) Hot Leaving Temp Sensor (Heat Recovery only)
I/O Expansion	J4-4	Sys 1 Motor Current
I/O Expansion	J4-5	SPARE
I/O Expansion	J4-8	SPARE
I/O Expansion	J4-10	Sys 2 Motor Current
I/O Expansion	J4-11	SPARE
I/O Expansion	J4-12	SPARE
I/O Expansion	J5-6	SPARE
I/O Expansion	J5-7	SPARE
I/O Expansion	J6-2	SPARE Sys 1 Fan Pressure Transducer (Heat Recovery only)
I/O Expansion	J7-2	Sys 2 Evaporator Inlet Refrigerant Temp Sensor (R-407c only)
I/O Expansion	J8-4	Sys 1 Discharge Temp Sensor
I/O Expansion	J8-6	Sys 2 Discharge Temp Sensor
I/O Expansion	J9-2	SPARE Sys 2 Fan Pressure Transducer (Heat Recovery only)
I/O Expansion	J10-6	Sys 2 Oil Temp Sensor
I/O Expansion	J10-7	Sys 1 Oil Temp Sensor
I/O Expansion	J11-2	Sys 1 Evaporator Inlet Refrigeration Temp Sensor (R-407c only)

## DIGITAL INPUTS

Table 15 lists all of the digital inputs and whether they are on the Microboard or the I/O Expansion Board.

**TABLE 15 - DIGITAL INPUTS**

Microboard	J4-1	Unit Switch
Microboard	J4-2	PWM Current Limit
Microboard	J4-3	SPARE Flow Switch (Euro CAT only)
Microboard	J4-4	PWM Temp Reset
Microboard	J4-5	Sys 1 Run Perm Sys 1 Sys Switch (Euro CAT only)
Microboard	J4-6	Print
Microboard	J4-7	Sys 2 Run Perm Sys 2 Sys Switch (Euro CAT only)
Microboard	J4-8	SPARE Hot Flow Switch (Heat Recovery only)

## ANALOG OUTPUTS

Table 16 lists all the analog outputs and what output board they are on.

**TABLE 16 - ANALOG OUTPUTS**

I/O Expansion	J2-1	Sys 1 Slide Valve
I/O Expansion	J12-1	Sys 2 Slide Valve

## 8.12 SENSOR CALIBRATION CHARTS

### Leaving Chilled Liquid Temperature and Return Chilled Liquid Temperature Sensors

Temperature °F (°C)	Voltage VDC
14° (-10°)	1.45
18° (-7.8°)	1.57
21° (-6.1°)	1.69
25° (-3.9°)	1.80
28° (-2.2°)	1.93
32° (0.0°)	2.05
36° (2.2°)	2.17
39° (3.9°)	2.30
43° (6.1°)	2.42
46° (7.8°)	2.54
50° (10°)	2.66
68° (20°)	3.22
86° (30°)	3.69
104° (40°)	4.05

**TEST POINTS:**

Leaving Water ..... Microboard J11-7/1  
 Return Water ..... Microboard J11-8/2

### Ambient Temperature Sensor

Temperature °F (°C)	Voltage VDC
14° (-10°)	0.97
23° (-5°)	1.20
32° (0.0°)	1.45
41° (5°)	1.72
50° (10°)	2.00
59° (15°)	2.29
68° (20°)	2.58
77° (25°)	2.85
86° (30°)	3.11
95° (35°)	3.35
104° (40°)	3.57

**TEST POINT:**

Test Point..... Microboard J11-9/3

### Oil & Discharge Temperature Sensors

Temperature °F (°C)	Voltage VDC
32° (0°)	0.282
50° (10°)	0.447
68° (20°)	0.676
86° (30°)	0.976
104° (40°)	1.34
122° (50°)	1.76
140° (60°)	2.20
158° (70°)	2.63
176° (80°)	3.04
194° (90°)	3.40
212° (100°)	3.71
230° (110°)	3.96
248° (120°)	4.17
266° (130°)	4.33
284° (140°)	4.46
302° (150°)	4.57

**TEST POINTS:**

**Oil Temperature:**

System 1: ..... Extension-board J10-7/3  
 System 2: ..... Extension-board J10-6/2

**Discharge Temperature:**

System 1: ..... Extension-board J8-4/1  
 System 2: ..... Extension-board J8-6/3

### Pressure Transducers

0 - 200 PSIG Transducer		0 - 400 PSIG Transducer	
Pressure PSIG	Voltage VDC	Pressure PSIG	Voltage VDC
0	0.5	0	0.5
25	1.0	50	1.0
50	1.5	100	1.5
75	2.0	150	2.0
100	2.5	200	2.5
125	3.0	250	3.0
150	3.5	300	3.5
175	4.0	350	4.0
200	4.5	400	4.5

Red Wire = 5V, Black wire = 0V, White/Green Wire = signal

**TEST POINTS:**

**Suction Pressure:**

System 1: ..... Microboard J13-7/1  
 System 2: ..... Microboard J14-7/1

**Oil Pressure:**

System 1: ..... Microboard J13-8/3  
 System 2: ..... Microboard J14-8/3

**Discharge Pressure:**

System 1: ..... Microboard J15-8/3  
 System 2: ..... Microboard J15-7/1

## 8.13 ISN CONTROL

### RECEIVED DATA (CONTROL DATA)

The microprocessor receives 8 data values from the ISN. The first 4 are analog values and the last 4 are digital values. These 8 data values are used as control parameters when in REMOTE mode. When the unit is in LOCAL mode, these 8 values are ignored. If the unit receives no valid ISN transmission for 5 minutes it will revert back to all local control values. Table 17 lists the 4 control parameters. These values are found under feature 54 on the ISN.

### TRANSMITTED DATA

After receiving a valid transmission from the ISN, the unit will transmit either operational data or history buffer data depending on the “History Buffer Request” on ISN PAGE 06. Data must be transmitted for every ISN page under feature 54. If there is no value to be sent to a particular page, a zero will be sent. Tables 18 and 19 show the data values and page listings for this unit.

**TABLE 17 – ISN RECEIVED DATA**

ISN PAGE	CONTROL DATA
P03	SETPOINT
P04	ISN Current Limit
P05	—
P06	—
P07	START/STOP COMMAND (0 = STOP, 1 = RUN)
P08	—
P09	—
P10	HISTORY BUFFER REQUEST (0 = CURRENT DATA, 1 = LAST HISTORY DATA)

**TABLE 18 – ISN TRANSMITTED DATA**

ISN Page	Character	Type	DXST Chiller Data
P11	8-11	Analog	Leaving Chilled Liquid Temp
P12	12-15	A	Return Chilled Liquid Temp
P13	16-19	A	Mixed Chilled Liquid Temp (optional) - YCAS Leaving Hot Liquid Temp - YCWS Hot Liquid Temp - Heat Recovery
P14	20-23	A	Sys 1 Suction Temperature
P15	24-27	A	Sys 1 Discharge Temperature
P16	28-31	A	Ambient Air Temperature
P17	32-35	A	Sys 1 Oil Temperature
P18	36-39	A	Sys 1 Oil Pressure
P19	40-43	A	Sys 1 Suction Pressure
P20	44-47	A	Sys 1 Discharge Pressure
P21	48-51	A	Sys 1 % Full Load Amps
P22	52-55	A	Sys 1 Total Run Hours
P23	56-59	A	Sys 1 Total Number of Stats
P24	60-63	A	Sys 1 Anti-Recycle Timer
P25	64-67	A	Anti-Coincident Timer
P26	68-71	A	Sys 2 Oil Temperature

TABLE 18 – ISN TRANSMITTED DATA (CONT'D)

ISN Page	Character	Type	DXST Chiller Data
P27	72-75	A	Sys 2 Oil Pressure
P28	76-79	A	Sys 2 Suction Pressure
P29	80-83	A	Sys 2 Discharge Pressure
P30	84-87	A	Sys 2 % Full Load Amps
P31	88-91	A	Sys 2 Total Run Hours
P32	92-95	A	Sys 2 Total Number of Starts
P33	96-99	A	Sys 2 Anti-Recycle Timer
P34	100-103	A	Sys 1 Evaporator Inlet Refrigerant Temp (R-407c only)
P35	104-107	A	Sys 2 Evaporator Inlet Refrigerant Temp (R-407c only)
P36	108	Diital	Chiller Run
P37	109	D	Chiller Alarm
P38	110	D	Evaporator Heater Status (YCAS)
P39	111	D	Evaporator Pump Status
P40	112	D	Hot Liquid Flow Switch (Heat Recovery)
P41	113	D	Sys 1 Spare Sys 1 Discharge Cooling Solenoid Status (Euro CAT, Low Temp)
P42	114	D	Sys 1 Liquid Line Solenoid Valve Status
P43	115	D	Sys 1 Economizer TXV Solenoid Status (YCAS) Sys 1 Oil Cooling Solenoid Status (YCWS) Sys 1 Condenser Solenoid Status (EURO CAT) Sys 1 Heat Recovery Solenoid Status (Heat Recovery)
P44	116	D	Sys 1 Wye-Delta
P45	117	D	Sys 2 Spare Sys 2 Discharge Cooling Solenoid Status (Euro CAT, Low Temp)
P46	118	D	Sys 2 Liquid Line Solenoid Valve Status
P47	119	D	Sys 2 Economizer TXV Solenoid Status (YCAS) Sys 2 Oil Cooling Solenoid Status (YCWS) Sys 2 Condenser Solenoid Status (Euro CAT) Sys 2 Heat Recovery Solenoid Status (Heat Recovery)
P48	120	D	Sys 2 Wye-Delta Relay
P49	121	D	—
P50	122	D	S1-1 Cooling Type: 0=Water, 1=Glycol
P51	123	D	S1-2 Ambient Ctrl: 0=Standard, 1=Low Ambient
P52	124	D	S1-3 Refrigerant Type: 0=R407c, 1=R-22
P53	125	D	S1-4 Unit Type: 0=YCWS, 1=YCAS
P54	126	D	S1-5 Motor Current Averaging: 0=Disabled, 1=Enabled
P55	127	D	S1-6 Heat recovery: 0=Disabled, 1=Enabled
P56	128	Coded	*Sys 1 Operational Code
P57	129	C	*Sys 1 Fault Code
P58	130	C	*Sys 2 Operatioanal Code
P59	131	C	*Sys 2 Fault Code
P60	132	C	Sys 1 Slide Valve Step
P61	133	C	Sys 1 Condenser Fan Stages Running (0-6)
P62	134	C	Sys 2 Slide Valve Step
P63	135	C	Sys 2 Condenser Fan Stages Running (0-6)
P64	136	C	Lead Compressor Number
P65	137	C	Debug Code

**TABLE 18 – ISN TRANSMITTED DATA (CONT'D)**

ISN Page	Character	Type	DXST Chiller Data
P66	138-141	Analog	Leaving Chilled Liquid Setpoint
P67	142-145	A	Low Leaving Chilled Liquid Temp Cutout
P68	146-149	A	Sys 1 EEV Output %
P69	150-153	A	Sys 2 EEV Output %
P70	154-157	A	Low Suction Pressure Cutout
P71	158-161	A	High Discharge Pressure Cutout
P72	162-165	A	Remote Leaving Chilled Liquid Setpoint
P73	166-169	A	Sys 1 Suction Superheat
P74	170-173	A	Cooling Range
P75	174-177	A	Sys 1 Discharge Superheat
P76	178-181	A	Sys 2 Suction Temperature
P77	182-185	A	Sys 2 Discharge Temperature
P78	186-189	A	Sys 2 Suction Superheat
P79	190-193	A	Sys 2 Discharge Superheat
P80	194	Digital	S1-7 Expansion Valve Type: 0=TXV, 1=EEV
P81	195	D	S1-8 SPARE
P82	196	D	—
P83	197	D	—
P84	198	D	—

**TABLE 19 – ISN OPERATIONAL AND FAULT CODES**

P56/58	C1 Operational Code	P57/59	C1 Fault Code
0	No Abnormal Condition	0	No Fault
1	Unit Switch Off	1	VAC Under Voltage
2	System Switch Off	2	Low Ambient Temperature
3	Lock - Out	3	High Ambient Temperature
4	Unit Fault	4	Low Leaving Chilled Liquid Temp
5	System Fault	5	High Discharge Pressure
6	Remote Shutdown	6	High Differential Oil Pressure
7	Daily Schedule Shutdown	7	Low Suction Pressure
8	No Run Permissive Flow Switch Open (Euro CAT)	8	High Motor Current
9	No Cool Load	9	LLSV Not On
10	Anti-Coincidence Timer Active	10	Low Battery Warning
11	Anti-Recycle Timer Active	11	High Oil Temperature
12	Manual Override	12	High Discharge Temperature
13	Suction Limiting	13	Improper Phase Rotation
14	Discharge Limiting	14	Low Motor Current / MP / HPCO
15	Current Limiting	15	Motor Current Unbalanced
16	Load Limiting	16	Low Differential Oil Pressure
17	Compressor Running	17	Ground Fault
		18	MP / HPCO
		19	Low Evaporator Temperature
		20	Incorrect Refrigerant Programmed
		21	Power Failure, Manual reset Required
		22	I/O Board Failure
		23	Low Superheat
		24	Sensor Fault
		25	Reprogram Unit Type
		26	MP / HPCO Inhibit
		27	Heat Recovery Select

\* The operational and fault codes are defined in Table 19. Note that this table of fault and operational codes is for all DX products. The codes that are grayed out are not used on this unit.

This page intentionally left blank.

## SECTION 9 - MAINTENANCE

### GENERAL REQUIREMENTS

The units have been designed to operate continuously, provided they are regularly maintained and operated within the limitations given in this manual. Each unit should be included in a routine schedule of daily maintenance checks by the operator/customer, backed up by regular service inspection and maintenance visits by a suitably qualified Service Engineer.

It is the responsibility of the owner to provide maintenance on the system.

It is entirely the responsibility of the owner to provide for these regular maintenance requirements and/or enter into a maintenance agreement with a York International service organization to protect the operation of the unit. If damage or a system failure occurs due to improper maintenance during the warranty period, YORK shall not be liable for costs incurred to return the unit to satisfactory condition.



*If system failure occurs due to improper maintenance during the warranty period, YORK will not be liable for costs incurred to return the system to satisfactory operation. The following is intended only as a guide and covers only the chiller unit components. It does not cover other related system components which may or may not be furnished by YORK. System components should be maintained according to the individual manufacturer's recommendations as their operation will affect the operation of the chiller.*

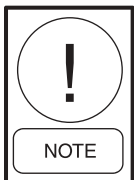

*This maintenance section applies to the basic unit only and may, on individual contracts, be supplemented by additional requirements to cover any modifications or ancillary equipment as applicable.*



*The Safety Section of this manual should be read carefully before attempting any maintenance operations on the unit.*

### Daily/Weekly Maintenance

The following maintenance checks should be carried out on a daily/weekly basis by the operator/customer. Please note that the units are not generally user serviceable and no attempt should be made to rectify faults or problems found during daily checks unless competent and equipped to do so. If in any doubt, contact your local YORK Service Agent.

**Unit Status:** Press the 'STATUS' key on the keypad and ensure no fault messages are displayed (refer to the MBCS Manual for explanation of messages and the Trouble Shooting section for courses of action).

**Refrigerant Leaks:** Visually check the heat exchangers, compressors and pipework for damage and gas leaks.

### CONDENSER COILS

Dirt and foreign material should not be allowed to accumulate on the condenser coil surfaces. Cleaning should be as often as necessary to keep coil clean.

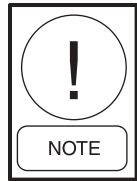

*Exercise care when cleaning the coil so that the coil fins are not damaged.*

**Operating conditions:** Read the operating pressures and temperatures at the control panel using the display keys and check that these are within the operating limitations in this Manual.

**Compressor oil level:** Check the compressor oil level after the compressor has been operating on 'FULL LOAD' for approximately half an hour. The oil level should be visible in the upper of the two sight glasses. When the compressor is operating at 'PART LOAD', the level may fall as far as half way down the lower sight glass but should not fall below this level. When the compressor returns to full load the level will return to the upper sight glass. If oil is added, be aware it is

"L" Type POE oil. Always add oil from a new unopened container. Dispose of the remaining oil using environmentally friendly procedures.

**Refrigerant charge:** When a system starts up, or sometimes after a change of capacity, a flow of bubbles will be seen in the liquid line sight glass. After a few minutes of stable operation, the bubbles should clear, leaving just liquid refrigerant showing in the sight glass.

### Chiller / Compressor Operating Log

A Chiller/Compressor Operating Log is supplied on the following page for logging compressor and chiller operating data.

Regular checks of the system should be performed to ensure that operating temperatures and pressures are within limitations, and that the operating controls are set within proper limits. Refer to the Operation, Start-Up, and Installation sections of this manual.

### Scheduled Maintenance

The maintenance operations detailed in the table following the Operating Log Form should be carried out on a regular basis by a suitably qualified Service Engineer. It should be noted that the interval necessary between each 'minor' and 'major' service can vary depending on, for instance, application, site conditions and expected operating schedule. Normally a 'minor' service should be carried out every three to six months and a 'major' service once a year. It is recommended that your local YORK Service Center is contacted for recommendations for individual sites.

### ON-BOARD BATTERY BACK-UP

U17 is the Real Time Clock chip that maintains the date/time and stores customer programmed setpoints. Anytime the chiller is to be off (no power to the microboard) for an extended time (weeks/months), the clock should be turned off to conserve power of the on-board battery. To accomplish this, the J11 jumper on the microboard must be moved to the "CLKOFF" position while power is still supplied to the microboard.



***The unit evaporator heater is 120VAC. Disconnecting 120VAC power from the unit, at or below freezing temperatures, can result in damage to the evaporator and unit as a result of the chilled liquid freezing.***

### OVERALL UNIT INSPECTION

In addition to the checks listed on this page, periodic overall inspections of the unit should be accomplished to ensure proper equipment operation. Items such as loose hardware, component operation, refrigeration leaks, unusual noises, etc. should be investigated and corrected immediately.



COMPRESSOR UNIT OPERATION



# CHILLER/COMPRESSOR Operating Log

YORK Order No. \_\_\_\_\_  
 Compr. Ser. No. \_\_\_\_\_  
 Unit Ser. No. \_\_\_\_\_  
 Refrigerant \_\_\_\_\_

Operating Log

Date											
Time											
Hour Meter Reading											
Equipment Room Temp./Outdoor Temp.		/	/	/	/	/	/	/	/	/	/
Compressor	Suction Pressure										
	Suction Temperature										
	Suction Superheat										
	Discharge Pressure										
	Actual Discharge Temperature										
	Oil Pressure										
	Oil Temperature										
	FLA % (Motor - )										
Oil Sep.	Oil Level (example  )	<input type="radio"/>	<input type="radio"/>	<input type="radio"/>	<input type="radio"/>	<input type="radio"/>	<input type="radio"/>	<input type="radio"/>	<input type="radio"/>	<input type="radio"/>	<input type="radio"/>
	Oil Added (gallons or liters)										
Evap.	Brine	Inlet Temperature									
		Outlet Temperature									
		Pressure Drop									
		Flow Rate - GPM or l/s									
Condenser	Air	Air On Temperature									
		Air Off Temperature									
	Water	Inlet Temperature									
		Outlet Temperature									
		Pressure Drop									
		Flow Rate - GPM or l/s									
	Leaving Liquid Refrigerant Temperature										

Remarks:

Note: Temperature and Pressure Units in °F and PSIG respectively unless otherwise noted.



## MAINTENANCE REQUIREMENTS FOR YORK YCAS SCREW CHILLERS

PROCEDURE	WEEKLY	QUARTERLY	SEMI-ANNUALLY	YEARLY	EVERY *_ HOURS
Check oil level in oil separator sight glass	X				
Check liquid line sight glass / moisture indicator	X				
Record system operating pressures and temperatures	X				
Check programmable operating setpoints and safety cutouts and assure they are correct for particular application.		X			
Check condenser coils for dirt/debris and clean if necessary	X				
Check compressor superheat on evaporator and economizer TXV's; Check condenser and economizer subcooling <sup>1</sup>			X		
Check compressor and evaporator heaters for operation		X			
Sample compressor oil and replace oil if necessary <sup>1</sup>				X	
Leak check the chiller <sup>1</sup>				X	
Disconnect power source and lock out; Check tightness of power wiring connections <sup>1</sup>				X	

\* Reserved for customer use for any special site determined requirements.

<sup>1</sup> This procedure must be performed at the specified time interval by an Industry Certified Technician who has been trained and qualified to work on this type of YORK equipment. A record of this procedure being successfully carried out must be maintained on file by the equipment owner should proof of adequate maintenance be required at a later date for warranty validation purposes.

## GENERAL PERIODIC MAINTENANCE CHECKS STANDARD UNITS

SERVICE SCHEDULE	MINOR SERVICE	MAJOR SERVICE All items under Minor Service plus:
Unit general:	Check thermal insulation. Check vibration isolators.	Check main structure. Check paint-work.
Refrigerant systems general:	Check relief valves. Check fusible plugs. Check for pipework damage. Check for leaks. Check moisture indicator. Check suction superheat. Check economizer superheat. Check liquid subcooling.	Check solenoid valves.
Compressors / Oil separator:	Check oil level. Check oil pressure. Check slide valve operation. Check compressor heater. Check condition of oil. Check discharge superheat.	
Evaporator	Check water flow. Check water pressure drop. Check heater.	Check water pH / glycol strength.
Air cooled condensers:	Check for airflow obstructions.  Check fins. Check fans and fan guards.	Brush fins. Clean with mild, low pH cleaner. Check fan motor bearings.
Power & Control system general:	Check panel condition. Check mains and control wiring. Check sensor location. Check mechanical HP cutouts. Check emergency stop. Check overload devices.	Check all connections. Check compressor contactors. Check fan contactors / overloads. Check sensor / transducer calibration. Check motor protectors.
Microprocessor controls:	Check fault history. Check program settings. Check HP / LP cutout functions Check pump-down function. Check load / unload function.	Check fan control function. Check ambient cut-out function.

## SECTION 10 - SPARE PARTS

### Recommended Spares

It is recommended that the following common spare parts are held for preventative of corrective maintenance operations.

Description	Part Number
Pressure Transducer 200PSI (14 Bar)	025-29583-000
Pressure Transducer 400PSI (28 Bar)	025-29139-001
Sensor, High Temperature	025-30440-000
Sensor, Ambient Temperature	025-28663-001
Sensor, Water Temperature	025-29964-000
Sensor, Water Temperature	025-29964-000
Oil Filter	026-35601-000
O-Ring	028-13849-000

Other spare parts vary depending on the unit model. Review the chiller Renewal Parts Manual or Contact your local YORK Sales and Service Center for information (Please quote the unit model number and serial number).

When ordering spare parts, we will require the following information to ensure the correct parts are supplied:

Full unit model number, serial number, application and details of the parts required.

All requests for parts should be made to your local YORK Sales and Service Center.

### Recommended Compressor Oils

The correct type of oil must be used in the unit as shown on the unit data plate and labels. Standard units use the following oils:

REFRIGERANT	COMPRESSOR OIL
R-22 and R407C	YORK Type L (5 Gal: 011-00592-000)



*The oil utilized is a POE oil. Once a container is opened, it quickly absorbs moisture. Any unused oil should be disposed of using environmentally friendly procedures.*

**For Parts, Service, or Sales,  
Call Toll Free:**

**1-866-YORK SRV  
(1-866-9675-778)**

## SECTION 11 - TROUBLESHOOTING GUIDE

PROBLEM	POSSIBLE CAUSE	ACTION
No display on panel - unit will not start	Main supply to control system OFF.	Switch on main supply if safe to do so.
	Emergency stop device off.	Check if control panel emergency stop switch and any remote emergency stop devices are in the OFF position. Turn to ON position (1) if safe to do so.
	CB3 tripped.	Check CB3.
	No supply to - T2.	Check 115VAC to L & 2.
	No 24VAC supply to power board.	Check wiring from - T2 to powerboard and fuse.
	No +12V output from powerboard.	Replace powerboard or isolate excessive load on the board.
NO RUN PERM displayed (No run permissive)	No liquid flow through the evaporator.	Ensure that liquid pumps are running. Valves are correctly set and flow is established.
	Flow switch or cycling contacts are not made.	Check that the flow switch is functional and is installed according to the manufacturer's instructions. Check cycling contacts.
SYS # HIGH OIL TEMP	Poor airflow through the condenser coils.	Check for airflow restrictions caused by blockages on intake faces of air coils.
	Measured temperature incorrect.	Check oil temp sensor and wiring.
Chiller FAULT: LOW AMBIENT TEMP displayed	Ambient air temperature is lower than the programmed operating limit.	Use the 'ambient temp.' key to display the temperature and confirm that the displayed value is approximately correct. The warning message should clear when the ambient air temperature rises above the programmed operating limit.
		Check the programmed settings are correct for the options fitted to the unit.
	Measured temperature is incorrect.	Check ambient sensor and wiring.
Chiller FAULT: HIGH AMBIENT TEMP displayed	Ambient air temperature is higher than the programmed operating limit.	Use the 'ambient temp.' key to display the temperature and confirm that the displayed value is approximately correct. The warning message should clear when the ambient air temperature falls below the programmed operating limit.
		Check that the programmed settings are correct for the options fitted to the unit.
	Recirculated air is affecting the sensor.	Check fans are operating correctly and the rotation is correct. Check for airflow recirculation.
	Measured temperature is incorrect.	Check ambient sensor and wiring.
Chiller FAULT: LOW WATER TEMP displayed	Leaving liquid drops below the programmed low limit faster than the unit can unload.	Check for restrictions in the liquid flow line. Check that the liquid flow is stable.
	Unit is not unloading.	Check the voltage to the unloader valve solenoid. Check that the compressor unloads correctly.
	Measured temperature is incorrect.	Check water temp sensor and wiring.
Chiller FAULT: VAC UNDERVOLTAGE displayed.	Poor main supply voltage.	Check main supply is stable and within allowable limits. Check for voltage dip on compressor start.

## TROUBLESHOOTING GUIDE - CONT'D

PROBLEM	POSSIBLE	ACTION
SYS # HIGH DSCH displayed (High discharge pressure trip)	Poor airflow through condenser coils.	Check for airflow restrictions caused by blockages on intake faces of air coils. Check for damaged fins/return bends. Check for correct fan operation and direction of rotation. Check for non-condensables (air) in system.
	Excessive refrigerant charge.	Check that the sub-cooling is correct.
	Measured pressure is incorrect.	Check discharge transducer and wiring.
SYS # HIGH DSCH TEMP displayed (High discharge temperature)	Suction superheat too high.	Check suction superheat is within range.
	Poor airflow through the condenser coils.	Check for airflow restrictions caused by blockages on intake faces of air coils.
	Measured temperature incorrect.	Check discharge sensor calibration, location and wiring.
SYS # DSCH LIMITING displayed (Discharge pressure unloading)	Discharge pressure unloading due to unit operating above load limit. See also SYS # HIGH DSCH.	Check chilled liquid temperature is within range. Check fan operation. Check if ambient air temperature is above design conditions. Check programmed unload point.
SYS # HIGH OIL PRESS DIFF is displayed. (High oil differential pressure.)	Ball valve in oil circuit closed.	Check ball valves are open position.
	Dirty / blocked oil filter.	Check and change oil filter cartridge.
SYS # LOW SUCTION displayed	Badly adjusted or faulty expansion valve.	Check superheat.
	Reduced evaporator performance.	Check for restricted chilled liquid flow. Check for fouled tube surfaces. Check superheat.
	Low refrigerant charge.	Check subcooling is correct. Check for leaks.
	Restricted refrigerant flow.	Check for blocked filter / drier. Check LLSV is opening correctly.
	Measured pressure incorrect.	Check suction pressure transducer and wiring.
SYS # LOW CURR/MP/HP displayed	Compressor current too low.	Check the compressor main supply voltage, fuses, contactors and wiring. Check main supply voltage is within tolerance. Check 2ACE MP fault code.
	Measured current is incorrect.	Check for defective Motor Protector Module.
	Compressor motor protector signal failure.	Check motor protector and wiring.
	Mechanical high pressure cut-out trip.	Check compressor discharge valve is open. Check cut-out and wiring.
	No motor cooling.	Check superheat. Check operation of economizer, TXV, and liquid solenoid valve.
SYS # CURR LIMITING displayed (Compressor current unloading.)	High compressor motor current has activated unloading.	Check if liquid temperature is within operating limits. Check if ambient air temperature is above operating limits.

## LIMITED WARRANTY YORK AMERICAS ENGINEERED SYSTEMS

### WARRANTY ON NEW EQUIPMENT

York International Corporation (“YORK”) warrants all equipment and associated factory supplied materials, or start-up services performed by YORK in connection therewith, against defects in workmanship and material for a period of eighteen (18) months from date of shipment. Subject to the exclusions listed below, YORK, at its option, will repair or replace, FOB point of shipment, such YORK products or components as it finds defective.

Exclusions: Unless specifically agreed to in the contract documents, this warranty does not include the following costs and expenses:

1. Labor to remove or reinstall any equipment, materials, or components.
2. Shipping, handling, or transportation charges.
3. Cost of refrigerants.

No warranty repairs or replacements will be made until payment for all equipment, materials, or components has been received by YORK.

### WARRANTY ON RECONDITIONED OR REPLACEMENT MATERIALS

Except for reciprocating compressors, which YORK warrants for a period of one year from date of shipment, YORK warrants reconditioned or replacement materials, or start-up services performed by YORK in connection therewith, against defects in workmanship or material for a period of ninety (90) days from date of shipment. Subject to the exclusions listed below, YORK, at its option, will repair or replace, FOB point of shipment, such materials or parts as YORK finds defective. However, where reconditioned or replacement materials or parts are placed on equipment still under the original new equipment warranty, then such reconditioned or replacement parts are warranted only until the expiration of such original new equipment warranty.

Exclusions: Unless specifically agreed to in the contract documents, this warranty does not include the following costs and expenses:

1. Labor to remove or reinstall any equipment, materials, or components.
2. Shipping, handling, or transportation charges.
3. Cost of refrigerant.

No warranty repairs or replacements will be made until payment for all equipment, materials, or components has been received by YORK.

ALL WARRANTIES AND GUARANTEES ARE VOID IF:

1. Equipment is used with refrigerants, oil, or antifreeze agents other than those authorized by YORK.
2. Equipment is used with any material or any equipment such as evaporators, tubing, other low side equipment, or refrigerant controls not approved by YORK.
3. Equipment has been damaged by freezing because it is not properly protected during cold weather, or damaged by fire or any other conditions not ordinarily encountered.
4. Equipment is not installed, operated, maintained and serviced in accordance with instructions issued by YORK.
5. Equipment is damaged due to dirt, air, moisture, or other foreign matter entering the refrigerant system.
6. Equipment is not properly stored, protected or inspected by the customer during the period from date of shipment to date of initial start.
7. Equipment is damaged due to acts of God, abuse, neglect, sabotage, or acts of terrorism.

*This warranty is in lieu of all other warranties and liabilities, express or implied in law or in fact, including the warranties of merchantability and fitness for a particular purpose. The warranties contained herein set forth buyer’s sole and exclusive remedy in the event of a defect in workmanship or materials. In no event shall york’s liability for direct or compensatory damages exceed the payments received by york from buyer for the materials or equipment involved. Nor shall york be liable for any special, incidental, or consequential damages. These limitations on liability and damages shall apply under all theories of liability or causes of action, including, but not limited to, contract, warranty, tort (including negligence) or strict liability. The above limitations shall inure to the benefit of york’s suppliers and subcontractors.*

## TEMPERATURE CONVERSION CHART

**TEMPERATURE CONVERSION CHART -  
ACTUAL TEMPERATURES**

° F	=	° C	° C	=	° F
0		-17.8	-18		-0.4
4		-15.6	-16		3.2
8		-13.3	-14		6.8
12		-11.1	-12		10.4
16		-8.9	-10		14
20		-6.7	-8		17.6
24		-4.4	-6		21.2
28		-2.2	-4		24.8
32		0.0	-2		28.4
36		2.2	0		32
40		4.4	2		35.6
44		6.7	4		39.2
48		8.9	6		42.8
52		11.1	8		46.4
56		13.3	10		50
60		15.6	12		53.6
64		17.8	14		57.2
68		20.0	16		60.8
72		22.2	18		64.4
76		24.4	20		68
80		26.7	22		71.6
84		28.9	24		75.2
88		31.1	26		78.8
92		33.3	28		82.4
96		35.6	30		86
100		37.8	32		89.6
104		40.0	34		93.2
108		42.2	36		96.8
112		44.4	38		100.4
116		46.7	40		104
120		48.9	42		107.6
124		51.1	44		111.2
128		53.3	46		114.8
132		55.6	48		118.4
136		57.8	50		122
140		60.0	52		125.6
144		62.2	54		129.2
148		64.4	56		132.8
152		66.7	58		136.4
156		68.9	60		140
160		71.1	62		143.6
164		73.3	64		147.2
168		75.6	66		150.8
172		77.8	68		154.4
176		80.0	70		158
180		82.2	72		161.6
184		84.4	74		165.2
188		86.7	76		168.8
192		88.9	78		172.4
196		91.1	80		176
200		93.3	82		179.6
204		95.6	84		183.2
208		97.8	86		186.8
212		100.0	88		190.4
216		102.2	90		194
220		104.4	92		197.6
224		106.7	94		201.2
228		108.9	96		204.8
232		111.1	98		208.4
236		113.3	100		212
240		115.6	102		215.6
244		117.8	104		219.2

**TEMPERATURE CONVERSION CHART -  
DIFFERENTIAL TEMPERATURES**

° F	=	° C	° C	=	° F
0		0	0		0
4		2.2	2		3.6
8		4.4	4		7.2
12		6.7	6		10.8
16		8.9	8		14.4
20		11.1	10		18
24		13.3	12		21.6
28		15.6	14		25.2
32		17.8	16		28.8
36		20	18		32.4
40		22.2	20		36
44		24.4	22		39.6
48		26.7	24		43.2
52		28.9	26		46.8
56		31.1	28		50.4
60		33.3	30		54

**PRESSURE CONVERSION CHART -  
GAUGE OR DIFFERENTIAL**

PSI	=	BAR	BAR	=	PSI
20		1.38	1.5		21.8
30		2.07	2		29
40		2.76	2.5		36.3
50		3.45	3		43.5
60		4.14	3.5		50.8
70		4.83	4		58
80		5.52	4.5		65.3
90		6.21	5		72.5
100		6.9	5.5		79.8
110		7.59	6		87
120		8.28	6.5		94.3
130		8.97	7		101.5
140		9.66	7.5		108.8
150		10.34	8		116
160		11.03	8.5		123.3
170		11.72	9		130.5
180		12.41	9.5		137.8
190		13.1	10		145
200		13.79	10.5		152.3
210		14.48	11		159.5
220		15.17	11.5		166.8
230		15.86	12		174
240		16.55	12.5		181.3
250		17.24	13		188.5
260		17.93	13.5		195.8
270		18.62	14		203
280		19.31	14.5		210.3
290		20	15		217.5
300		20.69	15.5		224.8
310		21.38	16		232
320		22.07	16.5		239.3
330		22.76	17		246.5
340		23.45	17.5		253.8
350		24.14	18		261
360		24.83	18.5		268.3
370		25.52	19		275.5
380		26.21	19.5		282.8
390		26.9	20		290
400		27.59	20.5		297.3

