



PRODUCT DRAWING

YORK INTERNATIONAL CORPORATION
P.O. Box 1592, YORK, PA 17405

Supersedes: Nothing

FORM 160.80-PW7 (1099)

**REMOTE MOTOR STARTER SPECIFICATIONS
MILLENNIUMYS (STYLE E)
ROTARY SCREW CHILLER
WITH GRAPHIC CONTROL CENTER**

CONTRACTOR _____
ORDER NO. _____
YORK CONTRACT NO. _____
YORK ORDER NO. _____

PURCHASER _____
JOB NAME _____
LOCATION _____
ENGINEER _____

REFERENCE DATE _____ APPROVAL DATE _____ CONSTRUCTION DATE _____

JOB DATA TO BE FILLED IN BY YORK INTERNATIONAL REPRESENTATIVE

Motor starters for use with YORK Rotary Screw Liquid Chilling Units must be furnished in accordance with the requirements of YORK Engineering Standard R-1079 (0398) to ensure proper functioning of unit and its associated controls.

THE STARTER(S) TO BE FURNISHED BY _____

a. QUANTITY _____ b. MANUFACTURER _____

c. SIZE AND/OR MODEL NUMBER OF STARTER _____

d. STARTER TYPE: ACROSS-THE-LINE

PRIMARY REACTOR _____ % TAP

PRIMARY RESISTOR _____ % TAP

AUTO-TRANSFORMER, CLOSED TRANSITION _____ % TAP

STAR-DELTA, OPEN TRANSITION STAR-DELTA, CLOSED TRANSITION

OTHER _____

} 200 – 600V: 80%, 65% or 57.7%
} 2300 – 5000V: 80% or 65%

MEDIUM VOLTAGE STARTERS ONLY: VACUUM BREAK CONTACTORS OTHER _____

e. TYPE ENCLOSURE – NEMA _____ (NEMA-1 UNLESS OTHERWISE SPECIFIED)

f. TYPE MOUNTING: FLOOR WALL

g. YORK UNIT MODEL NO. YS _____

h. POWER SUPPLY _____ VOLTS – 3-PHASE – _____ HERTZ

i. OPEN MOTOR: FULL LOAD AMPERES (FLA) _____

MOTOR LOCKED ROTOR AMPERES (LRA) _____ FULL VOLTAGE

MAXIMUM INRUSH AMPERES _____ REDUCED VOLTAGE

j. MOTOR NAMEPLATE HORSEPOWER (HP) _____

k. TYPE CONTROL CENTER: MICROCOMPUTER

l. POWER FACTOR CORRECTION CAPACITORS (WHEN REQUIRED) FULL LOAD PF

_____ UNCORRECTED, _____ CORRECTED, OR _____ KVAR REQUIRED AT _____ VOLTS

m. "MAIN CONTACTORS WILL DROP OUT WITHIN 4 CYCLES OF REMOVAL OF 115 VOLT "RUN" SIGNAL."

(This note to appear on starter wiring diagram.)

n. AMMETER REQUIRED: YES _____ (SINGLE-PHASE, THREE-PHASE), NO

p. CONTROL POWER TRANSFORMER REQUIRED: YES (1.5 NET KVA)

q. STRESS CONE SPACING REQUIRED: YES, NO

r. MANUAL RESET OVERLOAD RELAYS REQUIRED (MEDIUM VOLTAGE ONLY) YES, NO

(Required for units having U.L. or cU.L. approval on the YORK unit.)

s. CODE APPROVAL REQUIRED U.L. YES, NO cU.L. YES, NO

(Note: A U.L. or cU.L. listed starter must be supplied with a U.L. or cU.L. listed chiller)

t. REQUIRED APPROVAL, ACCESSORIES AND MODIFICATIONS: (DETAIL) INCLUDE CUSTOMER SPECIFICATIONS, AS REQUIRED.

This standard, defining the requirements of materials to be furnished or services performed, is not subject to interpretation.

1. SCOPE

1.1 This standard covers the special purchasing requirements of motor starters for use with YORK Millennium Screw Chillers models YS BABAS0 through YS FCFC55 with open motors per ASO drawings 024-25274D, 024-25275D, 024-25507D, 024-25508D, 024-26529D, 024-26530D, 024-26533D and 024-26534D.

2. RELATED STANDARDS

- 2.1 a. ANSI/IEEE Standard C57.13, Requirements for Instrument Transformers
- b. National Electrical Code (NEC), ANSI/NFPA- 70
- c. Underwriters Laboratories Standard U.L. 508
- d. Canadian Standards Association (CSA) Std. C22. 2 No.14-91
- e. NEMA Standards, Industrial Controls and Systems, Pub. No. ICS
- f. ASO Drawings 024-25274D, 024-25275D, 024-25507D, 024-25508D, 024-26529D, 024-26530D, 024-26533D and 024-26534D.

g. Underwriters Laboratories Standard U.L. 347

h. NEMA Standards, Motors and Generators MG-1

3. REQUIREMENTS

3.1 Starters supplied under this standard must comply with the requirements of NEC, ANSI/IEEE C57.13, and any additional codes or standards referenced on the purchase order.

3.2 On points of difference with the above referenced standards and codes, the requirements of this standard shall prevail. The starter circuit must be approved by ASO Engineering.

3.3 **Type of Starter** – The basic type of starter (across-the-line, auto-transformer, wye-delta, etc.) covered by this standard shall be as specified on the purchase order.

a. For auto-transformer, primary resistor and primary reactor starters, the design output voltage during starting shall not be less than 57.7% of unit

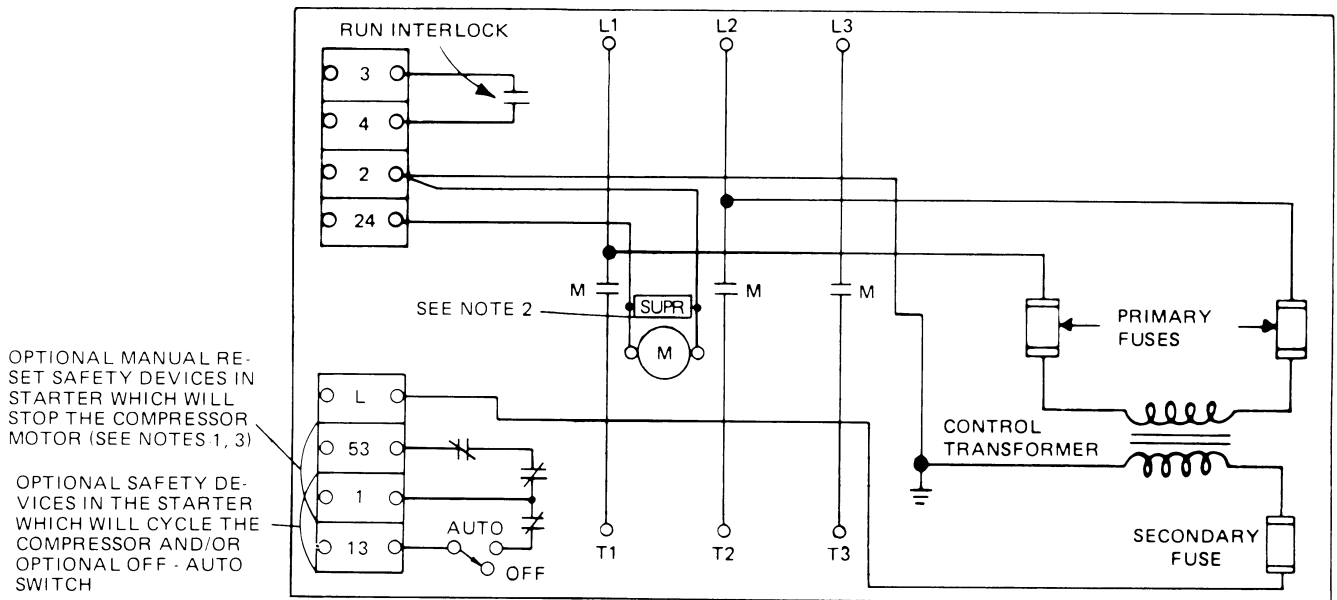

LD02361

NOTES:

- 1 – Connect the contacts of any voltage sensitive safety device(s) in circuit 13-1 rather than circuit 53-1. Any safety device(s) in the starter which may dropout due to loss of power must reset automatically when power is restored.
- 2 – Each 115V inductive load: i.e. motor starter coil, relay coil, etc., shall have a transient suppressor wired in parallel with its coil, physically located at the coil. Transient suppressor shall be a series RC device, 0.1 μ f, 100 ohms, 250VAC, U.L. approved – Rifa P/N PMR210ME6100M100, Electrocube P/N RG-1782-6 or equal.
- 3 – The jumper between terminals 53 & 1 in the chiller control panel must be removed when electro-mechanical starter overloads and/or safety devices are used.

FIG. 3.5 a – TYPICAL ACROSS-THE-LINE STARTER - 200 THRU 600VAC

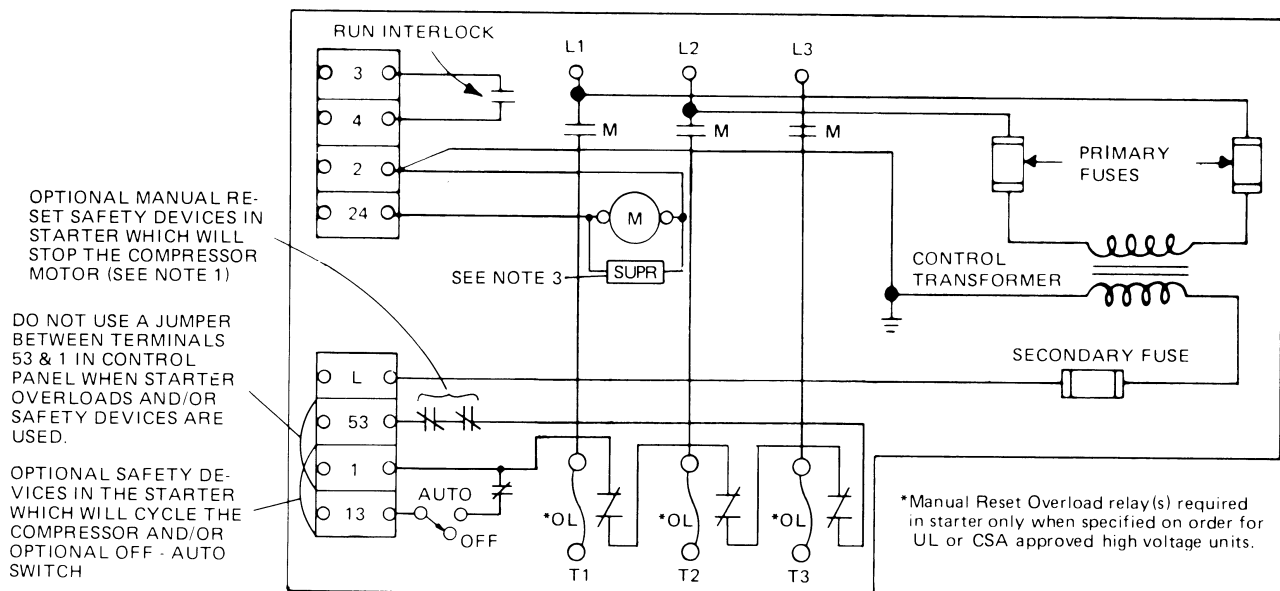

LD02362

NOTES:

- 1 - Connect the contacts of any voltage sensitive safety device(s) in circuit 13-1 rather than circuit 53-1. Any safety device(s) in the starter which may drop out due to loss of power must reset automatically when power is restored.
- 2 - Switchgear with automatically operated circuit breaker(s) may be used in lieu of contactors on high voltage units (above 600V).
- 3 - Each 115V inductive load: i.e. motor starter coil, relay coil, etc., shall have a transient suppressor wired in parallel with its coil, physically located at the coil. Transient suppressor shall be a series RC device, 0.1 mf 100 ohms, 250VAC, U.L. approved - Rifa P/N PMR210ME6100M100, Electrocube P/N RG-1782-6 or equal.

FIG. 3.5 b – TYPICAL ACROSS-THE-LINE STARTER - 2300 THRU 5000VAC

nameplate voltage for 200-600V and 65% of unit nameplate voltage for 2300-5000V. Refer special cases to York, PA, ASO Marketing.

b. Medium voltage starters are NEMA Class E2 which include an integral disconnect means, high interrupting capacity current-limiting fuses and either an air break, drawout contactor or a slide-out vacuum contactor as standard although not shown on Fig. 3.5 b.

3.4 **Enclosure** – Enclosure for the starter must be NEMA Type 1, General Purpose, unless specified otherwise.

3.5 **Control Circuit Wiring** – Control circuit wiring and terminal blocks shall be as shown in Fig. 3.5 a for 200 to 600VAC motor starters and shall be as shown in Fig. 3.5 b for 2300 to 5000VAC motor starters.

3.6 **Power Terminal Marking** – Starter line and load terminals must be identified by suitable markers.

3.7 **Nameplate Marking** – Nameplate shall be marked as follows:

“Volts, phase, Hertz, HP, FLA, LRA for refrigeration and air conditioning duty only per ASO Standard R-1079”. Also “U.L. or cU.L. listed under File No. _____” or “CSA Certified under File No. _____” when specified on purchase order.
NOTE: A U.L. or cU.L. listed starter must be supplied with a U.L. or cU.L. listed chiller.

3.8 Starter Control Circuit

a. Start-Stop Signal – The starter control circuit is actuated by a 115V \pm 10%, single phase, 50 or 60 Hertz “run” signal (1 amp full load, 10 amp inrush maximum) applied across terminals “24” and “2” from the YORK Control Center. If either the starter control voltage or current exceeds this rating, a separate additional control relay of proper rating shall be furnished within the starter. The “stop” function is accomplished by terminating the “run” signal.

b. All ungrounded conductors of the starter control circuit shall be protected by an over-current device rated not more than 300% of the current rating of the conductors or control relay contacts.

c. Control circuit must be designed to open main contactors within four (4) cycles (66.7 milliseconds) after removal of the 115V “Run” signal (including the dropout time of any relay added per Section 3.8(a)).

3.9 Solid State Overload protection is provided in the YORK Control Center.

3.10 For 2300 to 5000VAC motor starters, additional Manual Reset Overload Relays (OLs) are required as follows when specified on the order for U.L. or cU.L. approved units.

a. Three (3) (OLs) shall be supplied.

b. OLs shall be manual reset, ambient compensated, adjustable type, either thermal or mag-

netic or a YORK approved solid-state device such as the Westinghouse IQ-1000.

- c. OLs may sense either line or phase current.
- d. OLs may sense motor current directly (within the current and voltage limitations of the the OL coils), or they may be fed through two or three current transformers (CTs). Refer to paragraph 3.10 h.
- e. The OLs shall be factory set by the starter manufacturer for an ultimate trip point corresponding to 105% of motor full load current (FLA).
- f. If OLs sense the motor phase current of delta connected motors, the ultimate trip point shall correspond to the value shown in paragraph 3.10 e divided by 1.73.
 - (1) For units with power factor correction capacitors on load side of OL relays, the OL ultimate trip point must be decreased as follows:

$$\text{OL ultimate trip setting with PF correction} = \text{OL setting without PF correction} \times \left(\frac{\text{PF before correction}}{\text{PF after correction}} \right)$$

- g. OLs shall be adjusted for locked rotor trip time (seconds) as shown in Table 3.10g. OLs shall be temperature compensated to operate within the specified locked rotor trip time limits over an am-bient temperature range of 40 to 110°F.

TABLE 3.10 (g)

Type of Starting	Percent Voltage	Percent LRA		Overload Relay Trip Time (Sec.)
		Line	Load	
Across-The-Line	100	100	100	8-10
Wye Start-Delta Run**	100+	33	33	45-56
Auto-Transformer	80	64	80	18-22
	65	42.3	65	33-41
	57.7**	33	57.7	45-56
	50*	25	50	*
Primary Resistor Primary Reactor	80	80	80	18-22
	65	65	65	33-41
	57.7**	57.7	57.7	45-56
	50*	50	50	*

+ For Wye Start, line voltage is 100%, motor phase is 57.7%.
 * Refer all cases for 50% tap to York, PA ASO Marketing for approval.
 ** Wye-Delta and 57.7% tap available only for 200-600 volts.

- h. When used, current transformers must comply with ANSI/IEEE Requirements for Instrument Transformers, C57.13. The turns ratio shall appear in a readily visible location.
 - (1.) Current transformers feeding overloads must be sized to meet the accuracy and burden requirements of the overload relays.

- (2.) The same current transformers may be used to feed overload relays and a three phase ammeter circuit, provided the accuracy and burden requirements of both functions are satisfied. See paragraph 3.11.

3.11 **Current Transformers Supplying Current to Optional Ammeter** – The turns ratio shall appear in a readily visible location. Current transformer shall be sized to provide 2.4 to 4 amperes at motor full load current and have an accuracy class of 0.6 and burden rating of B-0.1 with continuous thermal current-rating factor of 1.0 at 30°C. See paragraph 3.15.

3.12 **Sequencing of Steps** – Sequencing of multiple step starters shall be a function of time. The starter manufacturer shall furnish timer(s) with an adjustable range of sixty (60) seconds, factory set by the starter manufacturer for a 42 ± 2 second final step, and with intermediate steps in proportion.

3.13 **Run Interlock** – All starters must be furnished with a normally open interlock which closes when full voltage is applied to the motor. The run interlock contact shall be pilot duty type, 125 VA at 115 volts. The interlock (terminals 3-4) must be suitable for reliable switching of 12 to 30 VA at 115 volts AC.

3.14 **Control Power Transformer** – A control power transformer shall be standardly supplied complying with the following:

- a. Capacity of the control transformer shall be 1.5 Net KVA.
- b. Primary shall be connected to power supply terminals through dual-element fuses in both conductors which are sized for no more than 250% of the primary current.
- c. Secondary voltage output shall be 115 volts ± 10%, single-phase, 50 or 60 Hertz as specified by the purchase order. The secondary windings shall be wired to control terminals “L” (line) and “2” (ground). A 15 amp dual element fuse shall be provided in the “L” (line) circuit.
- d. Circuit 2 (grounded circuit) shall be bonded to the starter enclosure for grounding. A No. 10-32 wire binding screw shall be provided adjacent to terminal 2. Circuit 2 shall be grounded at this point.
- e. Regulation must be such that the output voltage is 100-130V with load variation of 25-100% of rated load.

3.15 **Ammeters** – When specified by the purchase order, an ammeter shall be furnished to measure motor line current. The ammeter shall have a 5 ampere movement and a direct reading scale which indicates actual motor current. Two (2) different arrangements are recommended as follows:

- a. Single-phase ammeter circuit – The ammeter is installed in series with current transformer and a shorting switch is connected across the ammeter as shown in Fig. 3.15 a.

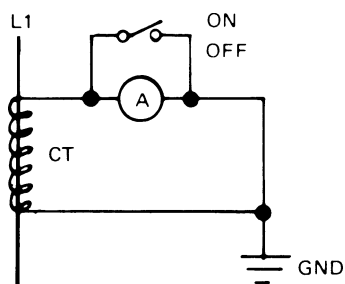

LD02363

FIG. 3.15a – SINGLE PHASE AMMETER CIRCUIT

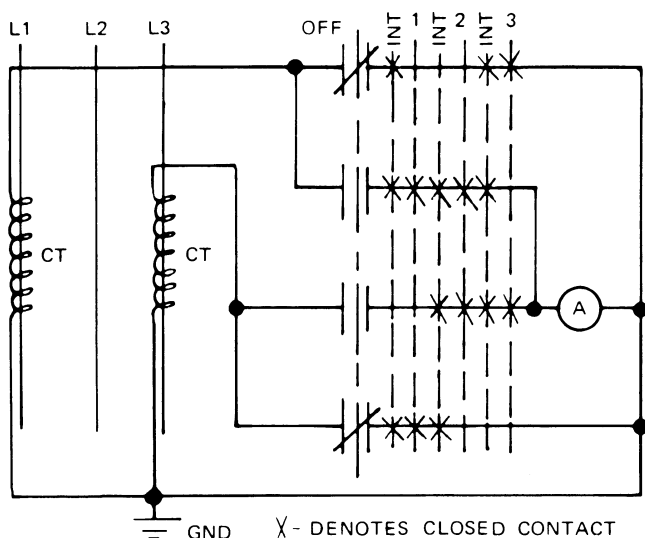

LD02364

FIG. 3.15b – 3-PHASE AMMETER CIRCUIT

- b. Three-phase ammeter circuit – Where indication of all three-phase currents is specified on the order, a 4 position selector switch shall be provided with a common ammeter. This is wired in conjunction with two CTs as shown in Fig. 3.15 b.
- c. If both an ammeter and power factor correction capacitors are specified, the ammeter shall be located in the circuit to indicate motor current.

3.16 **Space Requirements for Stress Cones** – The following minimum distance between point of entry of conduits and line and load connections shall be provided when the use of stress cones for field wiring is indicated.

Voltage	Minimum Distance
2-5 KV	14 inches
5.1-15 KV	19 inches

3.17 **Power Factors Correction Capacitors** – When PF correction capacitors are specified on the order they shall be connected to the load side of the starter in all cases except for open-transition, auto-transformer or wye-delta starting, where they shall be connected to the line side per NEMA Std., MG-1, Part 20. See paragraphs 3.10 f and 3.15 c for other considerations.

3.18 **Voltage Limits** – Starters must operate properly within the voltage limits below.

Hz	Rated Voltage	Nameplate Voltage(s)	Dip Voltage (60 sec. min.)	Continuous Operation	
				Min. Vtg.	Max. Vtg.
60	200V	200-208V	170V	180V	220V
60	230V	220-240V	196V	207V	254V
60	460V	440-480V	391V	414V	508V
60	575V	550-600V	489V	518V	635V
50	380V	380V	323V	342V	402V
50	400V	400V	340V	360V	423V
50	415V	415V	353V	374V	440V

Starters rated at voltages not listed above must operate continuously with voltage variation $\pm 10\%$ from nameplate. They also must operate for at least sixty (60) seconds at 15% below nameplate voltage during start-up.

4. CERTIFICATION

- 4.1 The starter manufacturer must provide three (3) sets (or more as specified on the purchase order) of certified drawings, identified with job name and ASO sales order number and showing dimensions and wiring diagram, as follows:
 - a. Two (2) sets (or more as specified) to source of purchase order.
 - b. One (1) set, for record purposes only, to Service Department 36BE, Applied Systems, York International Corporation, York, PA 17405-1592.

5. PACKAGING AND MARKING

- 5.1 The container used in shipment of the starter must be identified with the ASO Purchase Order, Job Name and ASO Sales Order Number, and any special markings specified.

6. PURCHASING

- 6.1 ASO Purchase Order is to specify:
 - a. Quantity
 - b. Manufacturer
 - c. Size and/or Model Number of Starter

- d. Type:
 Across-The Line
 Wye-Delta (open or closed transition)
 Auto-Transformer (closed transition) ___ % tap
 Primary Reactor or Primary Resistor ___ % tap
 Other _____
- e. Type Enclosure - NEMA _____
- f. Mounting (Floor or Wall)
- g. YORK Unit Model Number
- h. Power Supply, Volts, Phase, Hertz
- i. Rating Data: FLA, LRA, max. inrush amps, HP
- j. Motor Service Factor (if greater than 1.05) _____
- k. Power Factor Correction Capacitors (when required) Full Load PF _____ Uncorrected _____ Corrected or _____ KVAR @ _____ Volts
- l. Required Accessories and Modifications (detail) (include customer specifications, as required)
- m. Code Approval Required:
 U.L. - _____ YES _____ NO
 cU.L. - _____ YES _____ NO

NOTE: A U.L. or cU.L. listed starter must be supplied with a U.L. or cU.L. listed chiller.

- n. Manual Reset Overload Relays required (Medium voltage only) for U.L. or cU.L. approval.
 _____ YES _____ NO
- o. Job Name, and ASO Sales Order Number
- p. ASO Part Number, when applicable for shipment into ASO plants
- q. ASO Standard R-1079
- r. Main contactors will drop out within 4 cycles of removal of 115 volt "Run" signal." This note to appear on starter wiring diagram.

EXAMPLE:

One (1) Model ABC, Auto-Transformer, Closed Transition 65% Tap Starter, NEMA-1 enclosure, floor mounted, for use with YORK Model YS BABAS0-CF Millennium Screw Chiller at 460 volts -3-60 with 176 FLA, 1015 LRA and 426 amps maximum inrush and 154 HP, per ASO Standard R-1079, 1.5 KVA (15 amp) control power transformer, door mounted ammeter and three (3) phase ammeter selector switch, U.L. listed, customer XYZ, sales order number 00-000000.

