

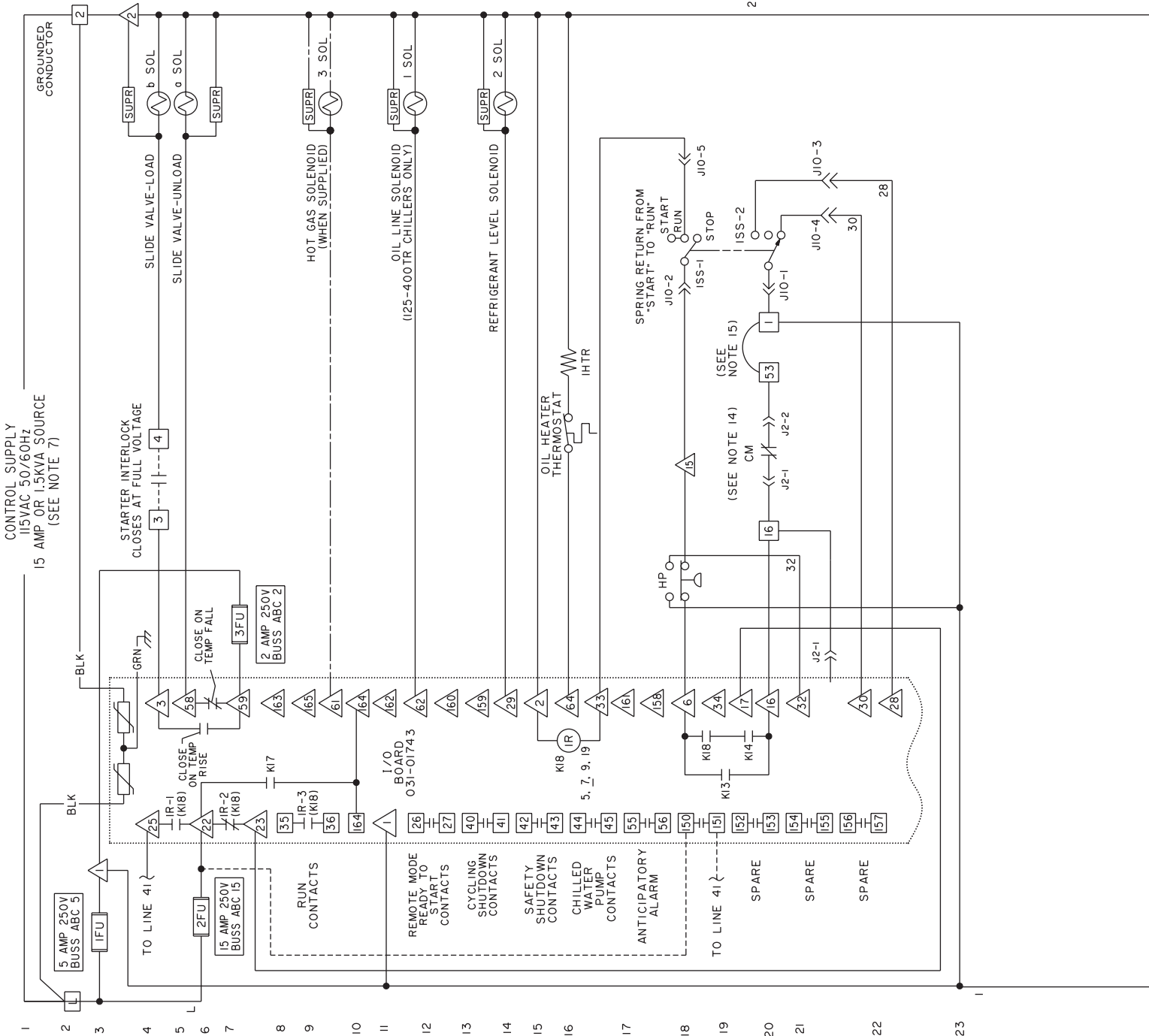

# ELEMENTARY DIAGRAM

035-17133 (REV. A)

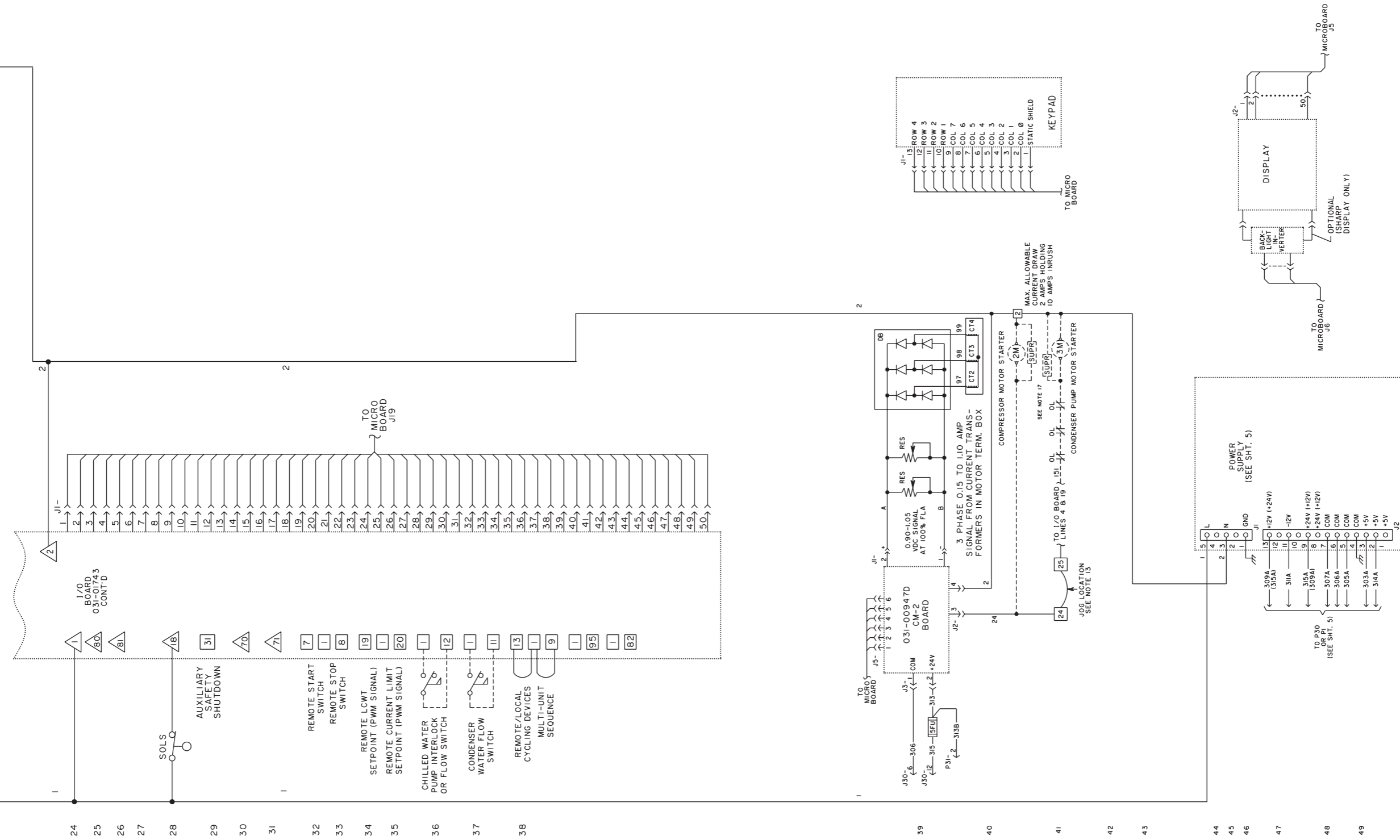



# ELEMENTARY DIAGRAM (Cont'd)

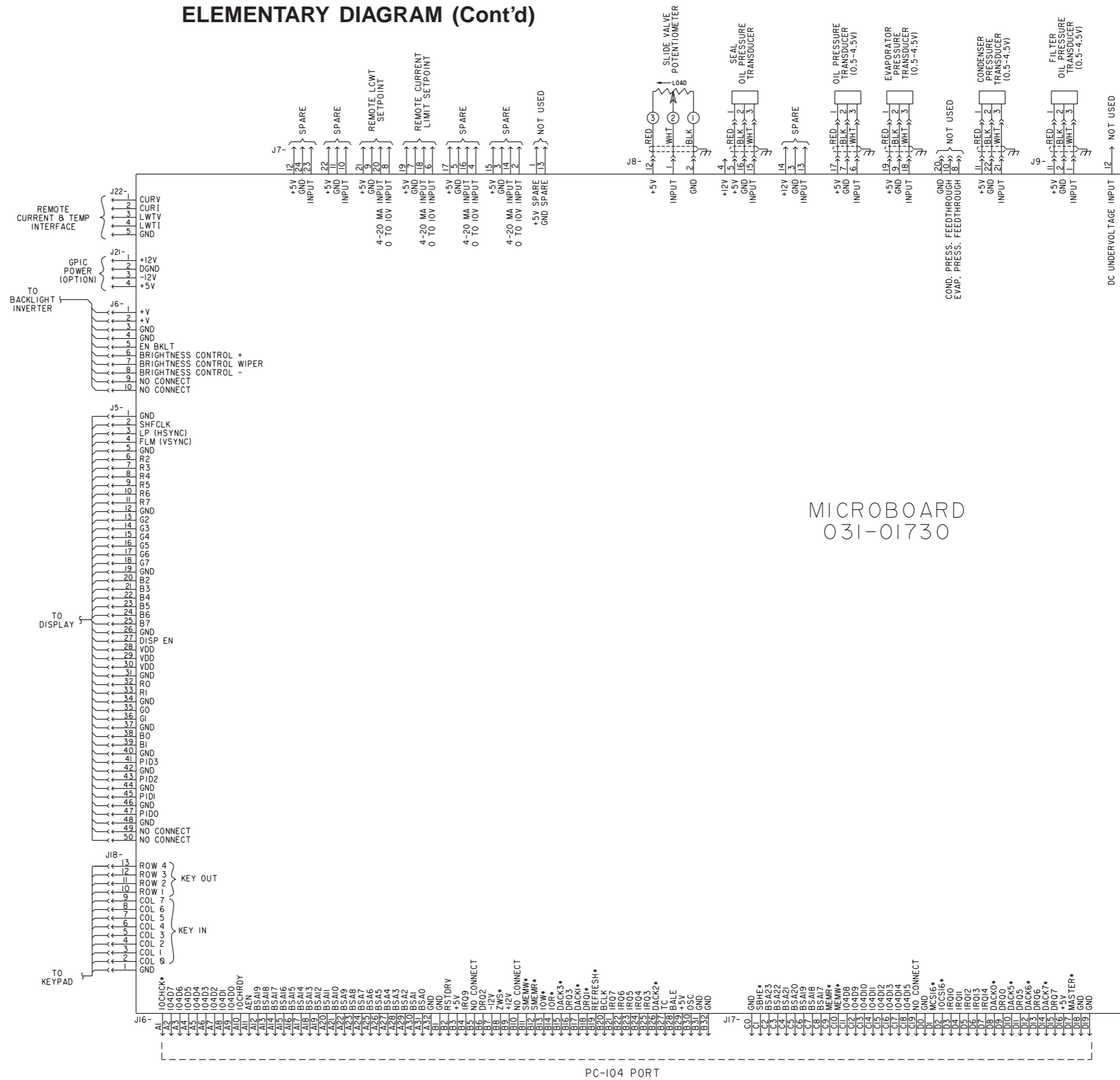

MICROBOARD  
031-01730

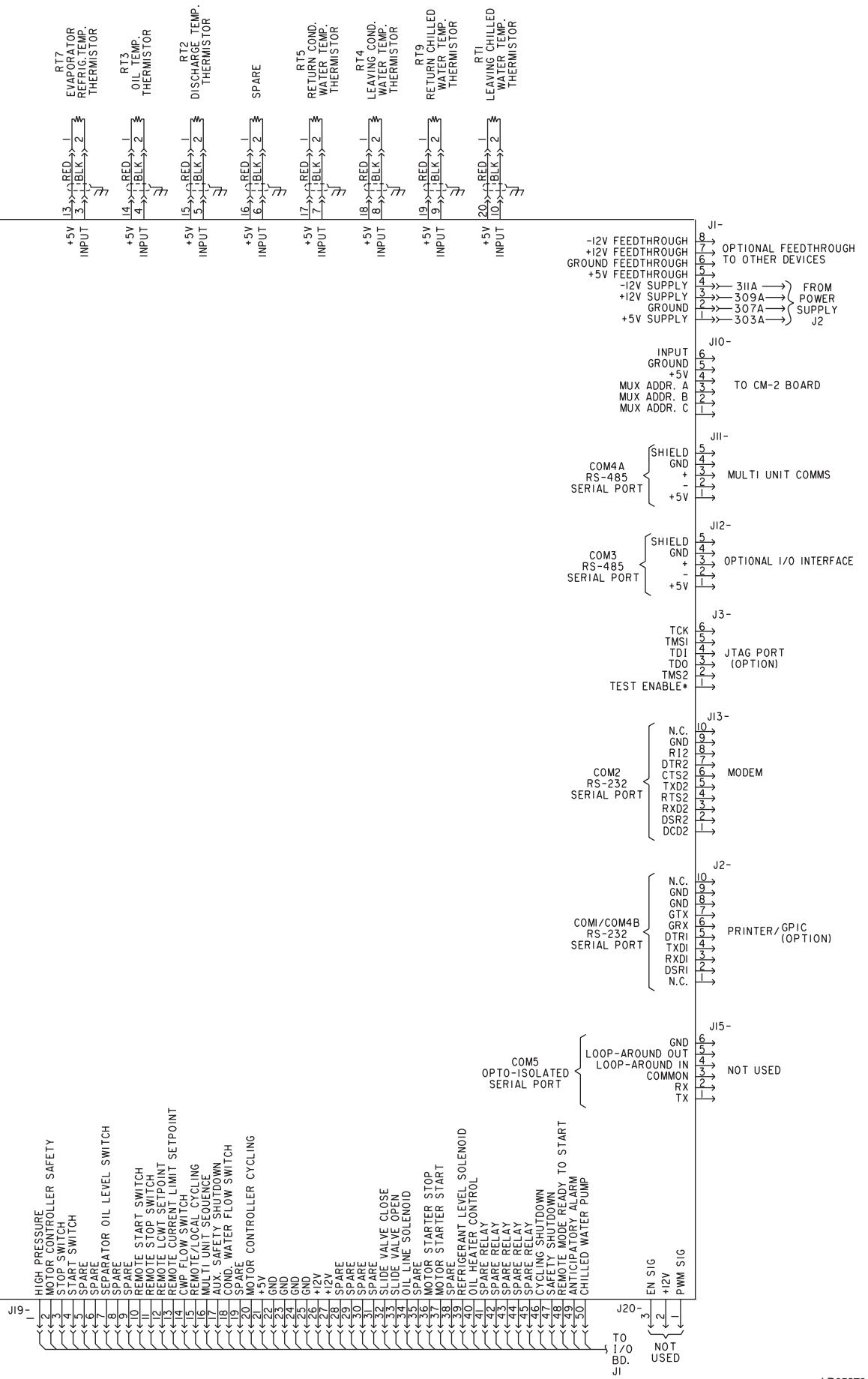

## TIMING DIAGRAM

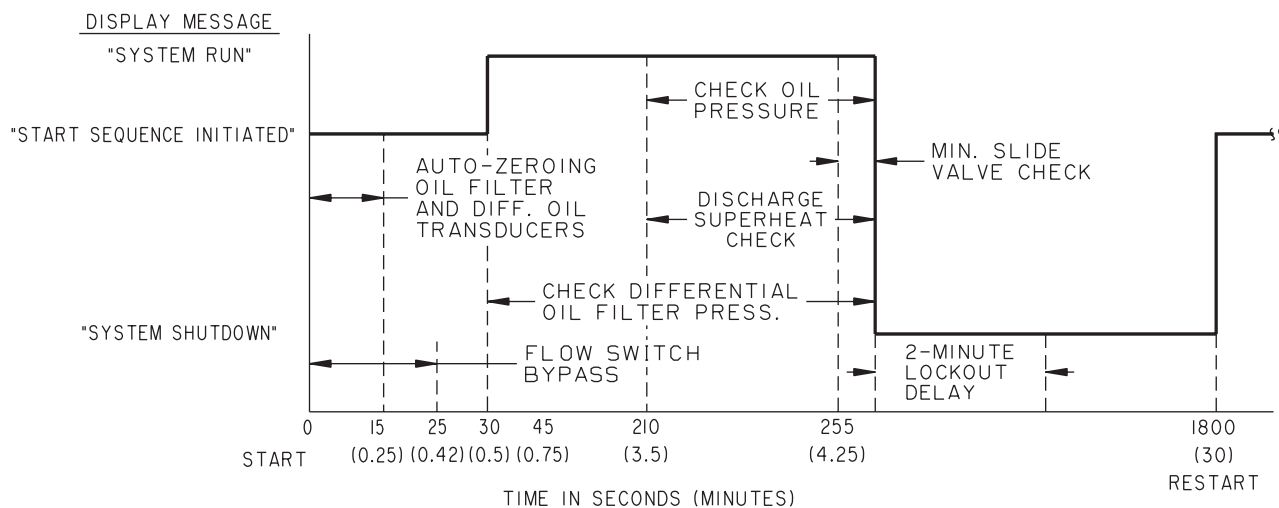





LD05868

### NOTES:

- This wiring diagram describes the standard electronic control scheme for use with an electromechanical starter. For details of standard modifications, refer to Product Form 160.80-PW5.
- Field wiring to be in accordance with the National Electrical Code as well as all other applicable codes and specifications. See Product Form 160.80-PW3 for field wiring connections.
- Numbers along the left side of diagram are line identification numbers. The numbers along the right side indicate the line number location of relay contacts. An underlined contact location signifies a normally closed contact.
- Main control panel Class 1 field wiring terminal connection points are indicated by numbers within a rectangle, i.e. 15. Main control panel factory wiring terminal connection points are indicated by numbers within a triangle, i.e. 5. Component terminal markings are indicated by numbers within a circle, i.e. C1. Numbers adjacent to circuit lines are the circuit identification numbers.
- To cycle unit on and off automatically with contacts other than those shown, install a cycling device between terminals 1 & 13 (line 38) (see note 9). If a cycling device is installed, jumper must be removed between terminals 1 & 13.
- Compressor motor starter with starter interlock contacts (rated 0.2 amps @ 120 volts A.C.) must be per Form 160.47-FA12. Control panel shall be grounded.
- Units installed in Canada must have a field supplied CSA approved 30 Amp disconnect switch and a 15 Amp dual element fuse mounted external to control panel for 115 volt control supply.
- To stop unit and not permit it to start again, install a stop device between terminals 7 & 8 (Line 33) (see note 9). A remote start-stop switch may be connected to terminals 7, 7 & 8 (Lines 32 & 33) (see note 9). Remote start-stop switch (Line 32) is operative only in the "remote" operating mode.
- Device contact rating to be 5 milliamperes @ 115 volts A.C.
- Low oil pressure (LOP) safety shutdown occurs when oil pressure - evaporator pressure differential is less than 15 psi following a 3 minute bypass at compressor start.
- Contact rating is 5 Amps resistive @ 120 volts A.C. or 240 volts A.C.
- \_\_\_\_\_
- To check motor rotation on initial start-up, install momentary switch between terminals 24 & 25 (line 41). Depress start switch. After approx. 30 seconds, jog motor with momentary switch. When proper rotation is obtained, replace momentary switch with jumper. Switch must have a minimum contact rating of 2 FLA., 10 LRA at 115 Volts A.C.
- Motor overload (CM) is set to trip at 105% FLA. During momentary power interruption (power fault), contact opens for 1 second.
- For high and low voltage units, the factory supplied jumper between 1 & 53 must be removed when electromechanical starter overloads and/or safety devices are used. For high voltage (2300-4160) UL and CUL approved units only, electromechanical compressor motor starter overloads (normally closed) must be connected between 1 & 53.
- Contact rating is 5 Amps resistive @ 250 Volts A.C. & 30 Volts D.C., 2 Amp inductive (.4 PF) @ 250 Volts A.C. & 30 Volts D.C.
- Each 115VAC field-connected inductive load: i.e. relay coil, motor starter coil, etc., shall have a transient suppressor wired in parallel with its coil, physically located at the coil. Spare transient suppressors and control circuit fuses are supplied in a bag attached to keypad cable clamp in left side of control panel.

LEGEND

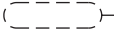
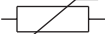
a SOL	SLIDE VALVE-UNLOAD
b SOL	SLIDE VALVE-LOAD
IHTR	500 WATT OIL HEATER
3M	CONDENSER PUMP MOTOR STARTER
IR	COMPRESSOR MOTOR/ IHTR HEATER CONTROL RELAY (KI8 - LOCATED ON I/O BD.)
ISOL	OIL LINE SOLENOID (I25-400TR CHILLERS ONLY)
2SOL	REFRIGERANT LEVEL SOLENOID (WHEN SUPPLIED)
ISS	DPDT 3 POSITION ROCKER SWITCH
CM	SOLID STATE OVERLOAD/POWER FAULT CONTACTS (PART OF CM-2 BOARD)
FDT5	FAULTY DISCHARGE TEMP. SENSOR
FLA	FULL LOAD AMPS (COMPRESSOR MOTOR)
FU	FUSE
HDT	REFRIG. HIGH DISCHARGE TEMP. (PROVIDED BY RT2)
HOP	HIGH OIL PRESSURE (PROVIDED BY TWO TRANSDUCERS)
HOT	HIGH OIL TEMPERATURE (PROVIDED BY RT3)
HP	HIGH PRESSURE CUTOUT
LEP	LOW EVAPORATOR PRESSURE (PROVIDED BY EVAP. PRESS TRANSDUCER)
LOT	LOW OIL TEMPERATURE (PROVIDED BY RT3)
LOP	LOW OIL PRESSURE
LWT	LOW WATER TEMPERATURE (PROVIDED BY RTI)
MOV	METAL OXIDE VARISTOR
OL	MOTOR STARTER OVERLOADS
RTI-RT9	RESISTANCE TEMPERATURE SENSING ELEMENT
RES	RESISTOR
SOLS	SEPARATOR OIL LEVEL SWITCH
<span style="border: 1px solid black; padding: 2px;">SUPR</span>	TRANSIENT SUPPRESSOR
TBI,TB3,TB5,	TERMINAL BLOCK, FACTORY WIRING — 
TB2,TB4	TERMINAL BLOCK, FIELD CONNECTION — 
TB6	TERMINAL BLOCK, FIELD (BOTTOM), FACTORY (TOP)
-----	FIELD WIRING
—————	FACTORY WIRING
.....	CIRCUIT BOARD OR ENCLOSURE BOUNDARY
	JACK (J1,J2,...)
	PLUG (P1,P2,...)
	WIRE ENTRANCE HOLE IN CONTROL PANEL
— · — · —	OPTION (WHEN SUPPLIED) BY YORK.
— · — · —	MECHANICAL LINKAGE
	SHIELDED CABLE
	METAL OXIDE VARISTOR
KI3,KI4,KI7	RELAYS MOUNTED ON I/O BOARD - SEE OPERATOR'S MANUAL

# CONNECTION DIAGRAM

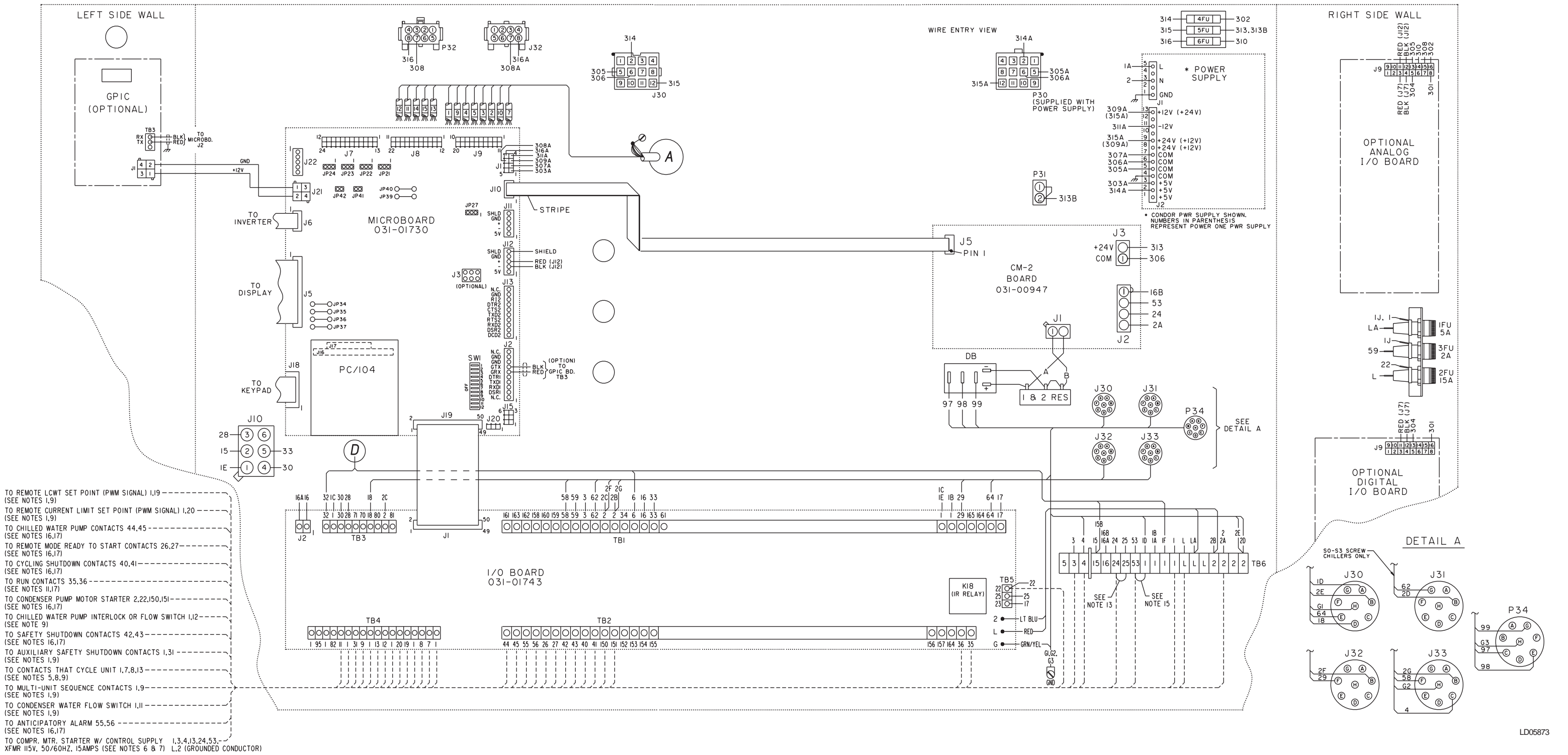

LD05873

(CONTINUED ON PAGES 8 & 9)

# CONNECTION DIAGRAM (Cont'd)

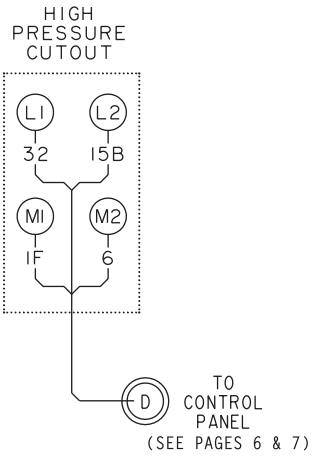

\* DENOTES WHT OR GRN WIRE

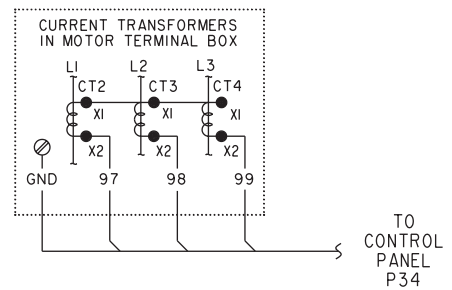
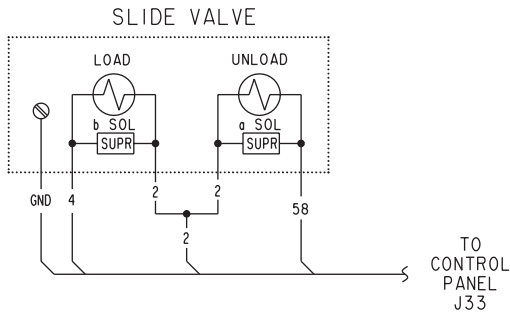
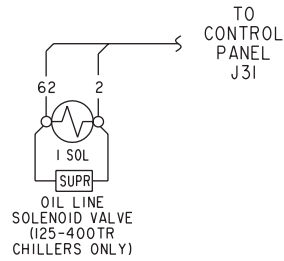
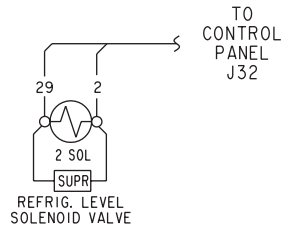
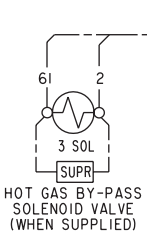
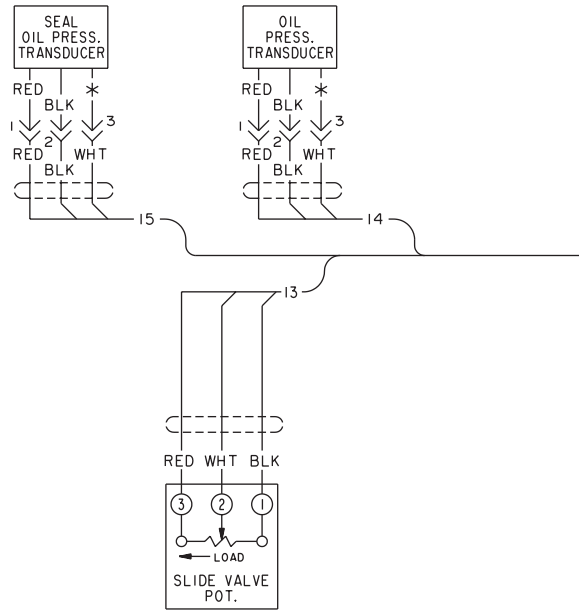

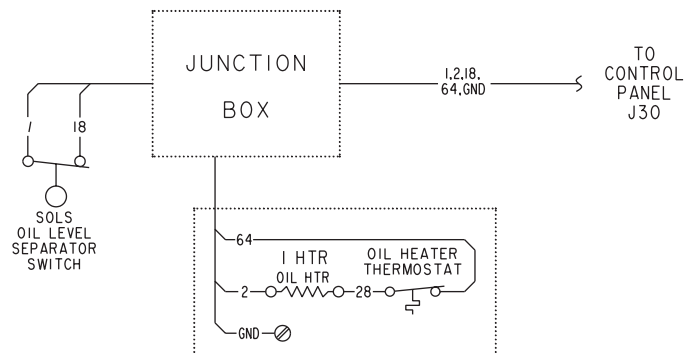
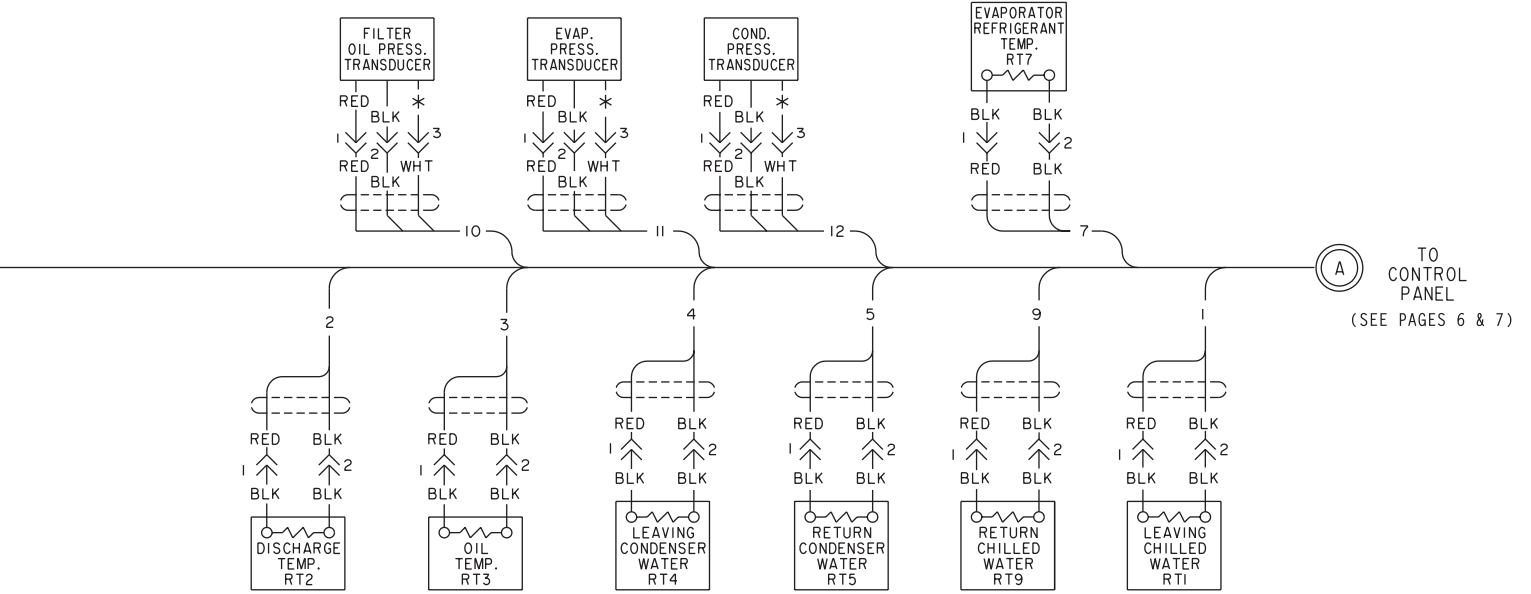

LD05874

# CONNECTION DIAGRAM (CONT'D)

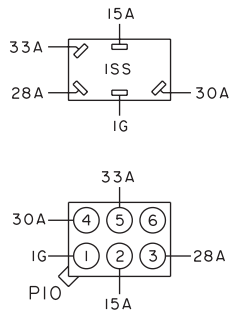
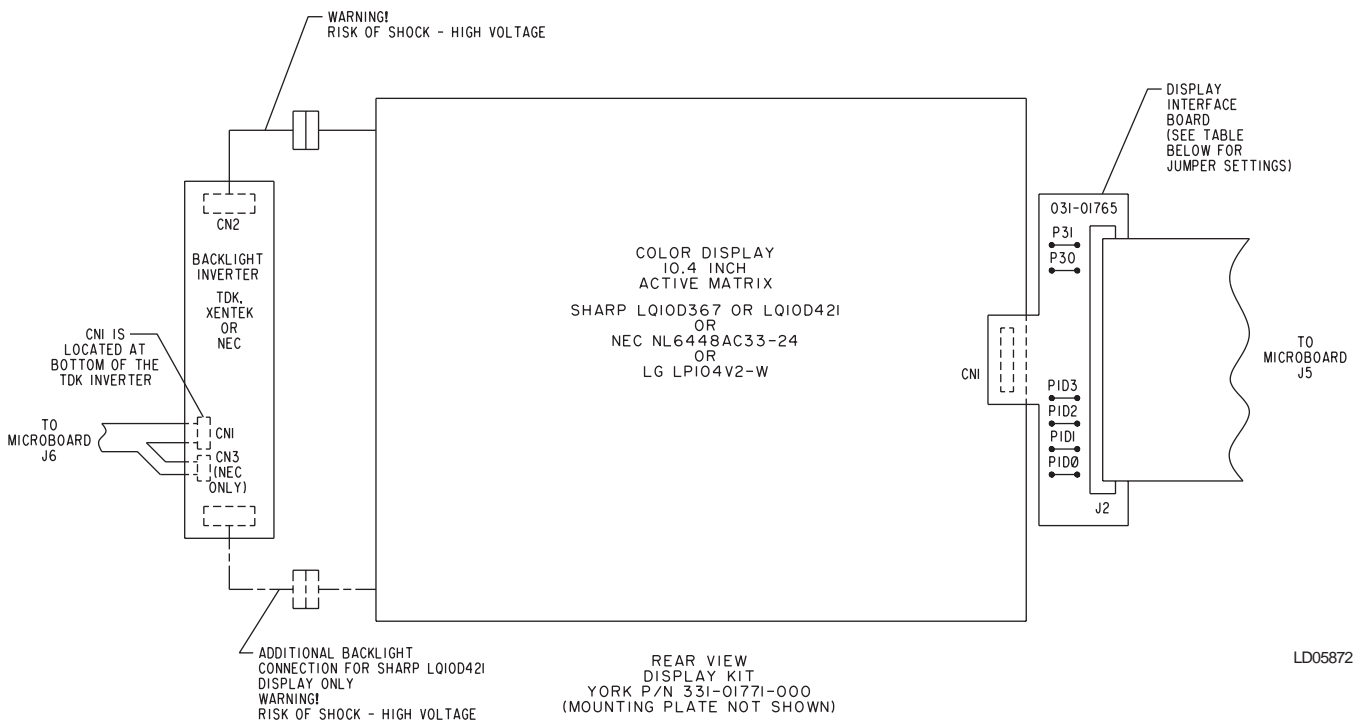

DISPLAY INTERFACE BOARD JUMPER SETTINGS

DISPLAY	P30	P31	PID3	PID2	PID1	PID0
SHARP LQ10D367	IN	IN	OUT	OUT	IN	OUT
SHARP LQ10D42I	IN	IN	OUT	OUT	IN	OUT
NEC OR LG	OUT	OUT	OUT	OUT	OUT	IN

PRESSURE-TEMPERATURE CHART							
APPLICATION		DEVICE	UNITS	OPERATING POINT			
CHILLED WATER	BRINE			ON RISE		ON FALL	
✓	✓	HDT	DEG.F/DEG.C	212/100		211/99.4	
✓	✓	HOT	DEG.F/DEG.C	170/76.7		169/76.1	
✓	✓	HOT WARNING	DEG.F/DEG.C	165/73.9		160/71.1	
✓	✓	LOP	SEE NOTE 10				
✓	✓	HP	PSIG/ kPa	CUT-OUT 270/1862	PROGRAMMABLE PER OPERATOR'S MANUAL FORM 160.80-01 *		CUT-IN 210/1448
✓		LEP (R-22)	PSIG/ kPa	CUT-IN 54.4/375	ALLOW SLIDE VALVE LOADING 57.5/396	INHIBIT SLIDE VALVE LOADING 56.2/387	CUT-OUT 54.3/374
✓		LEP (R-134 a)	PSIG/ kPa	CUT-IN 25.1/173	ALLOW SLIDE VALVE LOADING 28.0/193	INHIBIT SLIDE VALVE LOADING 27.0/186	CUT-OUT 25.0/172
✓	✓	HOP	PSID/ kPa	300/2068		299/2062	
✓	✓	FDTs	DEG.F/DEG.C	30.0/-1.10		29.9/-1.20	
✓		LWT	DEG.F/DEG.C	PROGRAMMABLE PER OPERATOR'S MANUAL FORM 160.80-01			
	✓	LWT	DEG.F/DEG.C				
✓	✓	CLOGGED OIL FILTER	PSID/ kPa	25.0/172		24.9/172	
✓	✓	DIRTY OIL FILTER WARNING	PSID/ kPa	20.0/138		19.9/137	

\* - FUNCTION PROVIDED BY CONDENSER TRANSDUCER

LD05869

