



MILLENNIUM[®]
ROTARY SCREW LIQUID CHILLERS

OPERATING & MAINTENANCE

Supersedes: 160.80-O1 (402)

Form 160.80-O1 (604)

MODEL YS (STYLE E)

**WITH OPTIVIEW™ CONTROL CENTER
FOR ELECTRO-MECHANICAL STARTER
& SOLID STATE STARTER**



00202VIP

IMPORTANT!

READ BEFORE PROCEEDING!

GENERAL SAFETY GUIDELINES

This equipment is a relatively complicated apparatus. During installation, operation, maintenance or service, individuals may be exposed to certain components or conditions including, but not limited to: refrigerants, oils, materials under pressure, rotating components, and both high and low voltage. Each of these items has the potential, if misused or handled improperly, to cause bodily injury or death. It is the obligation and responsibility of operating/service personnel to identify and recognize these inherent hazards, protect themselves, and proceed safely in completing their tasks. Failure to comply with any of these requirements could result in serious damage to the equipment and the property in

which it is situated, as well as severe personal injury or death to themselves and people at the site.

This document is intended for use by owner-authorized operating/service personnel. It is expected that this individual possesses independent training that will enable them to perform their assigned tasks properly and safely. It is essential that, prior to performing any task on this equipment, this individual shall have read and understood this document and any referenced materials. This individual shall also be familiar with and comply with all applicable governmental standards and regulations pertaining to the task in question.

SAFETY SYMBOLS

The following symbols are used in this document to alert the reader to areas of potential hazard:



DANGER indicates an imminently hazardous situation which, if not avoided, will result in death or serious injury.



CAUTION identifies a hazard which could lead to damage to the machine, damage to other equipment and/or environmental pollution. Usually an instruction will be given, together with a brief explanation.



WARNING indicates a potentially hazardous situation which, if not avoided, could result in death or serious injury.

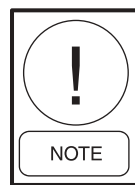

NOTE is used to highlight additional information which may be helpful to you.



External wiring, unless specified as an optional connection in the manufacturer's product line, is NOT to be connected inside the micro panel cabinet. Devices such as relays, switches, transducers and controls may NOT be installed inside the micro panel. NO external wiring is allowed to be run through the micro panel. All wiring must be in accordance with YORK's published specifications and must be performed ONLY by qualified YORK personnel. YORK will not be responsible for damages/problems resulting from improper connections to the controls or application of improper control signals. Failure to follow this will void the manufacturer's warranty and cause serious damage to property or injury to persons.

CHANGEABILITY OF THIS DOCUMENT

In complying with YORK's policy for continuous product improvement, the information contained in this document is subject to change without notice. While YORK makes no commitment to update or provide current information automatically to the manual owner, that information, if applicable, can be obtained by contacting the nearest YORK Applied Systems Service office.

It is the responsibility of operating/service personnel as to the applicability of these documents to the equipment in question. If there is any question in the mind of operating/service personnel as to the applicability of these documents, then, prior to working on the equipment, they should verify with the owner whether the equipment has been modified and if current literature is available.

REFERENCE INSTRUCTIONS

DESCRIPTION	FORM NO.
SOLID STATE STARTER (MOD "A") – OPERATION & MAINTENANCE	160.46-OM3.1
SOLID STATE STARTER (MOD "B") – OPERATION & MAINTENANCE	160.00-O2
INSTALLATION	160.80-N1
OPTIVIEW CONTROL CENTER – SERVICE INSTRUCTIONS	160.80-M1
WIRING DIAGRAM – UNIT WITH ELECTRO-MECHANICAL STARTER	160.80-PW1
WIRING DIAGRAM – UNIT WITH MOD "B" SOLID STATE STARTER	160.80-PW2
RENEWAL PARTS – UNIT	160.80-RP1
RENEWAL PARTS – OPTIVIEW CONTROL CENTER	160.80-RP3

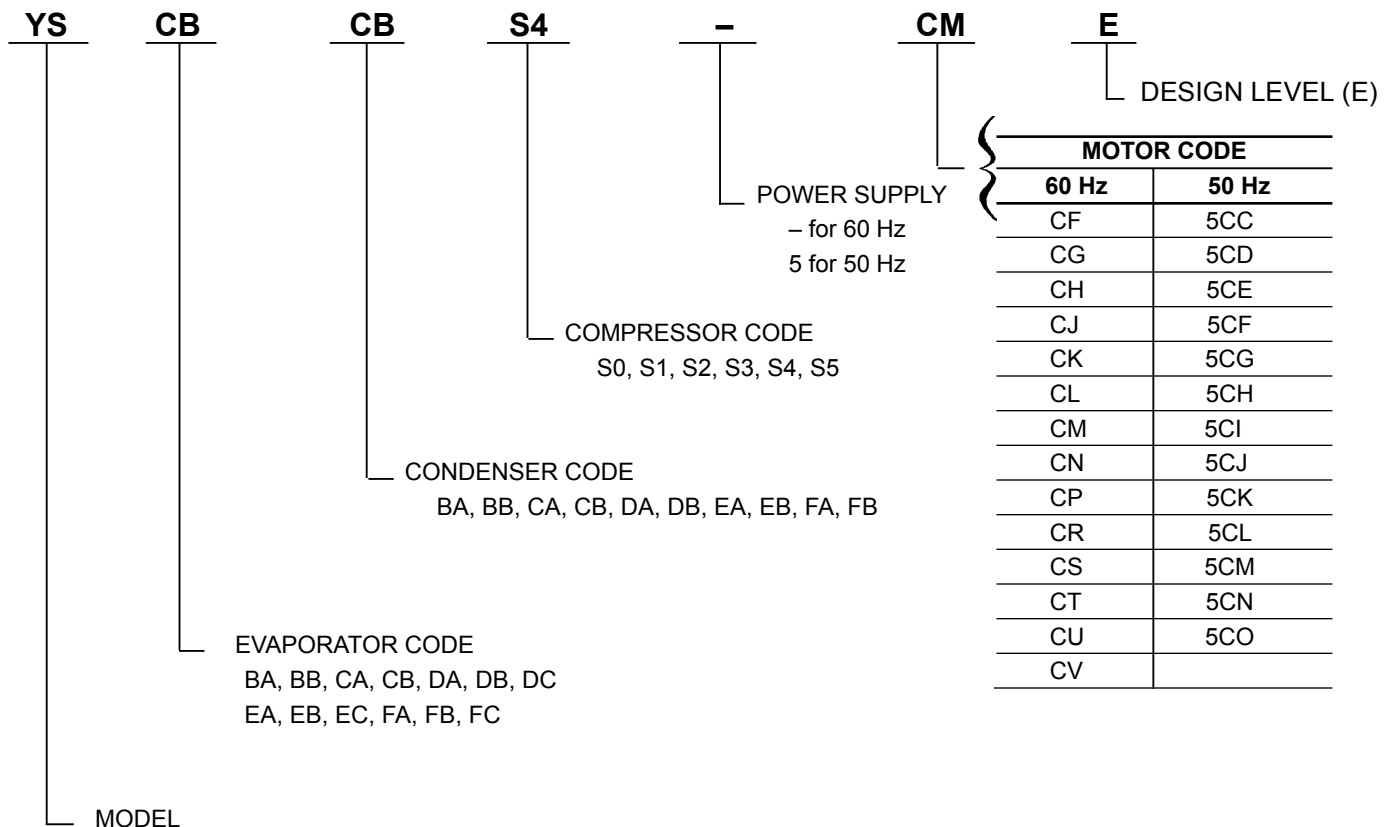

TABLE OF CONTENTS

- SECTION 1 - DESCRIPTION OF SYSTEM AND FUNDAMENTALS OF OPERATION 8**
 - SYSTEM OPERATION DESCRIPTION 8
 - CAPACITY CONTROL..... 9
 - CHILLER OPERATION OVERVIEW 10
- SECTION 2 - OPTIVIEW CONTROL CENTER 16**
 - INTRODUCTION 16
 - CONTROL CENTER 18
 - INTERFACE CONVENTIONS 19
 - OVERVIEW 19
 - DISPLAY ONLY 19
 - PROGRAMMABLE 19
 - NAVIGATION 20
 - LANGUAGES 21
 - ANALOG INPUT RANGES 21
 - HOME SCREEN 22
 - SYSTEM SCREEN 24
 - EVAPORATOR SCREEN 26
 - CONDENSER SCREEN..... 30
 - VARIABLE ORIFICE CONTROL SCREEN 32
 - COMPRESSOR SCREEN..... 34
 - HOT GAS BYPASS SCREEN 36
 - SLIDE VALVE CALIBRATION SCREEN 38
 - OIL SEPARATOR SCREEN 40
 - ELECTRO-MECHANICAL STARTER SCREEN..... 42
 - MOD "A" SOLID STATE STARTER SCREEN 44
 - MOD "B" SOLID STATE STARTER SCREEN 46
 - SETPOINTS SCREEN 48
 - SETUP SCREEN 50
 - SCHEDULE SCREEN 52
 - USER SCREEN..... 54
 - COMMS SCREEN..... 55
 - PRINTER SCREEN..... 56
 - SALES ORDER SCREEN 57
 - OPERATIONS SCREEN 58
 - HISTORY SCREEN 60
 - HISTORY DETAILS SCREEN 62
 - SECURITY LOG 63

TABLE OF CONTENTS (CONT'D)

SECURITY LOG DETAILS	64
CUSTOM VIEW SCREEN	65
CUSTOM VIEW SETUP	66
TREND SCREEN	68
TREND SETUP SCREEN	70
ADVANCED TREND SETUP SCREEN	72
COMMON SLOTS SCREEN	74
MASTER SLOT NUMBERS LIST FOR USE WITH TREND FEATURE.....	75
DISPLAY MESSAGES	77
SECTION 3 - PRINTERS	88
PRINTERS.....	89
PRINTER SETUP	90
CONTROL CENTER SETUP.....	91
SI METRIC CONVERSION	99
TEMPERATURE:.....	99

LIST OF FIGURES

FIG. 1 – MODEL YS MILLENNIUM CHILLER.....	8
FIG. 2 – REFRIGERATION FLOW THROUGH ROTARY SCREW CHILLER	9
FIG. 3 - CONTROL CENTER.....	18
FIG. 4 - HOME SCREEN.....	22
FIG. 5 - SYSTEM SCREEN.....	24
FIG. 6 - EVAPORATOR SCREEN.....	26
FIG. 7 - CONDENSER SCREEN	30
FIG. 8 - VARIABLE ORIFICE CONTROL SCREEN.....	32
FIG. 9 - COMPRESSOR SCREEN	34
FIG. 10 - HOT GAS BYPASS SCREEN	36
FIG. 11 - SLIDE VALVE CALIBRATION SCREEN	38
FIG. 12 - OIL SEPARATOR SCREEN.....	40
FIG. 13 - ELECTRO-MECHANICAL STARTER SCREEN	42
FIG. 14 - MOD “A” SOLID STATE STARTER SCREEN.....	44
FIG. 15 - MOD “B” SOLID STATE STARTER SCREEN.....	46
FIG. 16 - SETPOINTS SCREEN.....	48
FIG. 17 - SETUP SCREEN	50
FIG. 18 - SCHEDULE SCREEN.....	52
FIG. 19 - USER SCREEN	54
FIG. 20 - COMMS SCREEN.....	55
FIG. 21 - PRINTER SCREEN	56
FIG. 22 - SALES ORDER SCREEN.....	57
FIG. 23 - OPERATIONS SCREEN	58
FIG. 24 - HISTORY SCREEN	60
FIG. 25 - HISTORY DETAILS SCREEN.....	62
FIG. 26 - SECURITY LOG.....	63
FIG. 27 - SECURITY LOG DETAILS.....	64
FIG. 28 - CUSTOM VIEW SCREEN.....	65
FIG. 30 - TREND SCREEN.....	68
FIG. 31 - TREND SETUP SCREEN.....	70
FIG. 32 - ADVANCED TREND SETUP SCREEN	72
FIG. 33 - COMMON SLOTS SCREEN.....	74
FIG. 34 – PRINTERS	88
FIG. 35 – SAMPLE PRINTOUT (STATUS REPORT).....	92
FIG. 36 – SAMPLE PRINTOUT (SETPOINT REPORT)	93
FIG. 37 – SAMPLE PRINTOUT (SCHEDULE).....	94
FIG. 38 – SAMPLE PRINTOUT (SALES ORDER).....	95
FIG. 39 – SAMPLE PRINTOUT (HISTORY)	96
FIG. 40 – SAMPLE PRINTOUT (SECURITY LOG REPORT).....	97
FIG. 42 – SAMPLE PRINTOUT (CUSTOM SCREEN REPORT).....	98
FIG. 41 – SAMPLE PRINTOUT (TREND DATA NEW OR EXISTING POINTS).....	98

This page intentionally left blank

SECTION 1

DESCRIPTION OF SYSTEM AND FUNDAMENTALS OF OPERATION

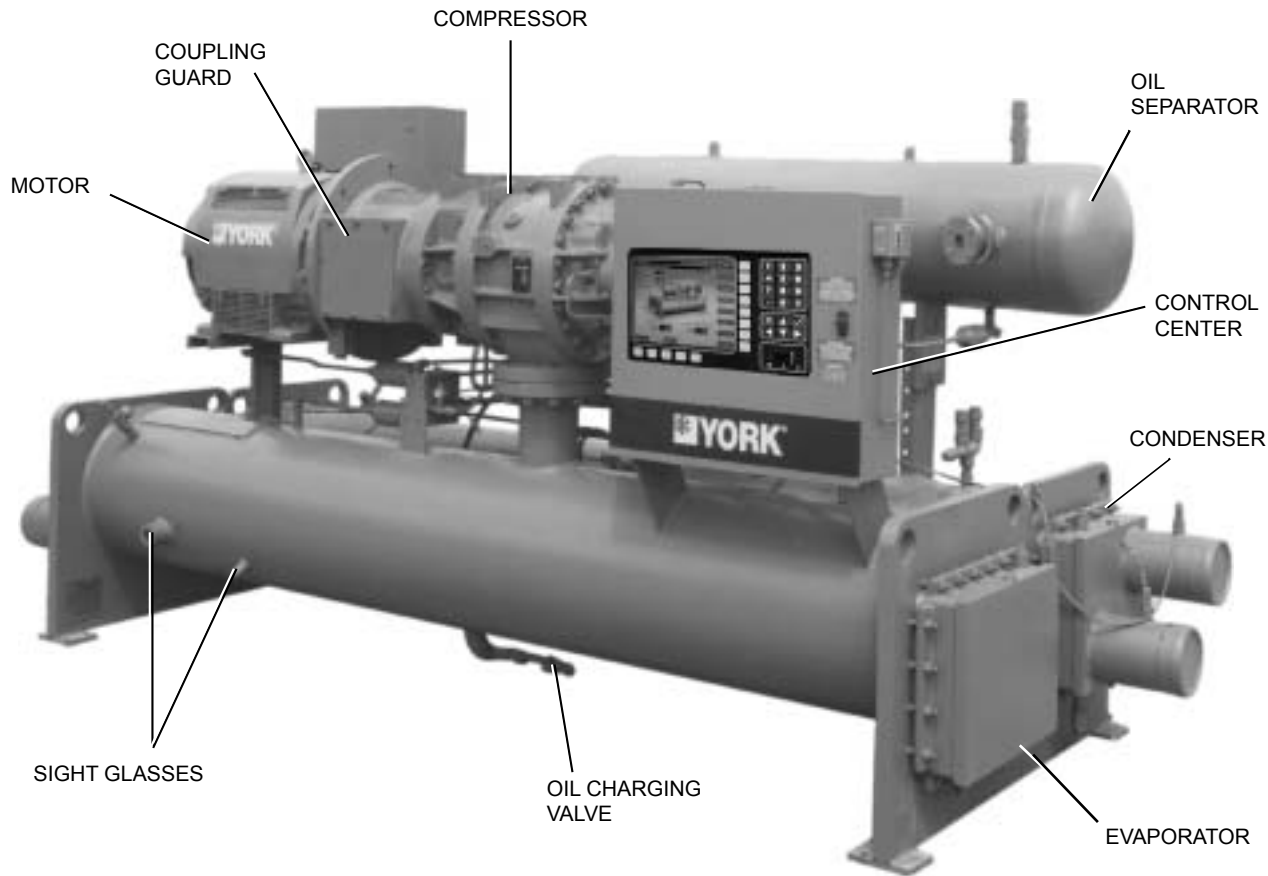

FIG. 1 – MODEL YS MILLENNIUM CHILLER

SYSTEM OPERATION DESCRIPTION (SEE FIG. 2)

The YORK Model YS Millennium Chiller is applied to large air conditioning systems, but may be used on other applications. The chiller consists of an open motor connected to a rotary screw compressor with an adaptor support and coupling, an oil separator, a condenser, a cooler and an OptiView Control Center.

The chiller is controlled by a modern state of the art Graphic Control Center that monitors its operation. The Control Center is programmed by the operator to suit job specifications. Automatic timed start-ups and shutdowns are also programmable to suit nighttime, weekends, and holidays. The operating status, temperatures, pressures, and other information pertinent to operation of the chiller are automatically displayed and read on a graphic display. Other displays can be observed by pressing the keys as labeled on the Control Center. The chiller with the OptiView Control Center is applied with an electro-mechanical starter, or YORK Solid State Starter (optional).

There could be either of two different Solid State Starters applied. New production chillers are equipped with the Mod "B" Solid State Starter. This starter contains a combination Logic/Trigger Board that interfaces to the Control Center with a serial communication link. Earlier vintage starters, such as those encountered in Control Center retrofit applications are equipped with the Mod "A" starter. This starter contains a Trigger Board that interfaces to a Logic Board that is installed inside the Control Center.

In operation, a liquid (water or brine to be chilled) flows through the cooler, where boiling refrigerant absorbs heat from the liquid. The chilled liquid is then piped to fan coil units or other air conditioning terminal units, where it flows through finned coils, absorbing heat from the air. The warmed liquid is then returned to the chiller to complete the chilled liquid circuit.

The refrigerant vapor, which is produced by the boiling action in the cooler, flows to the compressor where rotary screw action compresses it increasing its pressure and temperature and discharges it into the oil separator section which removes the oil before the high pressure gas flows into the condenser tube bundle. Water flowing through the condenser tubes absorbs heat from the refrigerant vapor, causing it to condense. The condenser water is supplied to the chiller from an external source, usually a cooling tower. The condensed refrigerant drains from the condenser into the liquid return line, where the variable orifice meters the flow of liquid refrigerant to the cooler to complete the refrigerant circuit.

The major components of a chiller are selected to handle the refrigerant, which would be evaporated at full load

design conditions. However, most systems will be called upon to deliver full load capacity for only a relatively small part of the time the unit is in operation.

CAPACITY CONTROL

The major components of a chiller are selected for full load capacities, therefore capacity must be controlled to maintain a constant chilled liquid temperature leaving the cooler. A slide valve arrangement located on the rotary screw compressor compensates for various load conditions. The slide valve arrangement is controlled by the OptiView Control Center and unit controls that sense the building load conditions. The control center sends signals to the solenoid valve that loads and unloads the slide valve with the use of compressor oil under

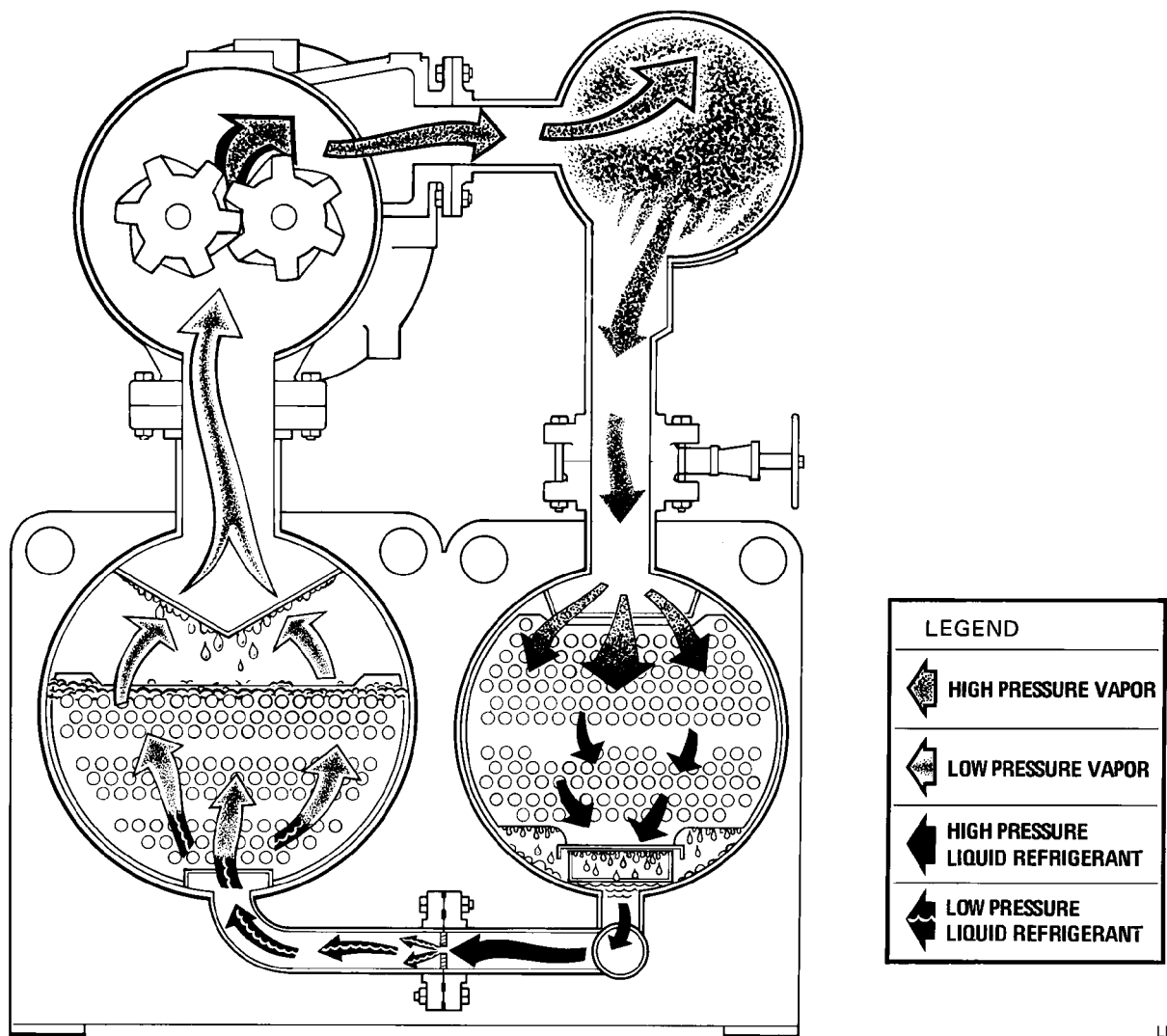

FIG. 2 – REFRIGERATION FLOW THROUGH ROTARY SCREW CHILLER

hydraulic pressure. A cylinder located in the inlet end of the compressor houses a spring loaded shaft and pistons (slide valve) which is fed through its ports by pressurized compressor oil. The flow of the oil is controlled by the equalizing solenoid valve which modulates to load and unload the slide valve that increases or decreases the amount of refrigerant flowing to the compressor, thus controlling the chiller capacity.

CHILLER OPERATION OVERVIEW

In the following description, reference is made to procedures that should be performed only by a Service Technician. Instructions for these procedures are in YORK Service Manual 160.80-M1 and require Service access level.

The chiller will be permitted to start only if there are no Safety or Cycling shutdown condition in effect and the slide valve position is $< 30\%$.

When a Local or Remote start signal is applied, the 30 second start sequence is initiated. "START SEQUENCE INITIATED", along with a 30 second countdown timer, is displayed on the System Status line of the Display. The Oil Line Solenoid Valve 1SOL (125-400TR chillers only) is energized (opened) for the first 15 seconds. During the first 15 seconds, the pressure transducer **Auto-Zeroing** (if enabled) is performed. To compensate for Transducer differences and assure differential pressure accuracy, the transducer outputs that are involved in creation of differential values are compared in the Auto-Zeroing process. During this period, the output of both transducers that are creating the differential pressure are compared to determine the offset between them. Since system pressures should be equalized during this period, both transducers will be sensing the same pressure and their outputs should indicate the same pressure. However, to compensate for differences between transducers and assure differential pressure accuracy, this offset is added or subtracted from the actual differential pressure during System Run to produce the displayed differential value. For example, the displayed "Differential Oil Pressure" is the result of subtracting the output of the Evaporator Transducer from the Oil Transducer. If the Oil Pressure transducer indicates 1.0 PSIG greater than the Evaporator transducer during the auto-zeroing period, then 1.0 PSIG will be subtracted from the dis-

played PSID value during system run. Similarly, if the Oil Pressure Transducer indicates 1.0 PSIG less than the Evaporator Transducer during the this period, then 1.0 PSIG is added to the displayed PSID value during system run. In certain applications, the Auto-Zeroing might have to be disabled. Only a Service Technician should disable this feature.

After the 15 second Auto-zeroing period has elapsed, the Oil Line Solenoid Valve is de-energized (closed) for the remainder of the Start Sequence Period. The Chilled Liquid Flow Switch position is checked 25 seconds into the Start Sequence period. If not closed, a Cycling shutdown is performed.

At the completion of the 30 second start sequence, the Oil Line Solenoid Valve is energized (opened), "SYSTEM RUN" is displayed and the start signal is applied to the compressor motor starter.

Upon entering System Run, a continuous load signal is applied to the slide valve actuator until the Slide Valve position is $\geq 25\%$. This more rapidly increases system pressure differential to facilitate oil flow through the compressor. During the first 3 minutes of System Run, the Slide Valve position is maintained at a minimum of 25%. If the position decreases to 22%, a load signal is applied until the position is again $\geq 25\%$.

After the chiller has been running for > 3 minutes, the Slide Valve minimum position must be maintained to that which will provide enough oil flow through the compressor to maintain sufficient oil level in the Oil Separator. There are two different selectable methods that can be employed as the **Minimum Load Control Source: Slide Valve or Motor FLA**. If "Slide Valve" is selected, the minimum allowed slide valve position is fixed at 15%. If "Motor FLA" is selected, the minimum allowed position is that which will maintain the compressor motor current above the programmed "Minimum Load FLA" Setpoint (15% to 70% FLA). The MINIMUM LOAD CONTROL SOURCE and associated setpoints are programmed by a Service Technician. Regardless of which method is in control, if the slide Valve position decreases to $<$ the minimum allowed position, a 1 second load pulse is applied every 3 seconds until it meets the minimum allowed position. While the Slide Valve unloading is inhibited, "MINIMUM LOAD – LOAD LIMIT" is displayed.

After the chiller has been running for >3 minutes, the Slide Valve is opened or closed to control the Leaving Chilled Liquid Temperature to the Leaving Chilled Liquid Temperature Setpoint. If the actual temperature is $\geq 0.4^\circ\text{F}$ above or below the Setpoint, varying duration load or unload pulses, as appropriate, are applied to the Slide Valve Actuator to correct the error per the following schedule: (as explained later, unload pulses are not applied in Ice Storage Mode).

Error ($^\circ\text{F}$)	Action
+4.0	3.3 sec. load pulse every 7.8 sec.
+2.5	2.4 sec. load pulse every 8.7 sec.
+1.0	0.75 sec. load pulse every 10.4 sec.
-1.0	0.75 sec. unload pulse every 10.4 sec.
-2.5	2.4 sec. unload pulse every 8.7 sec.

Normally, the load and unload pulses are of the same duration for the same error above or below the Leaving Chilled Liquid Temperature Setpoint. This provides proper operation in most applications. However, in those applications where load is quickly removed from the chiller, faster unloading could be necessary. A Service Technician can adjust the **Sensitivity** setpoint to provide faster unloading.

The following **Load Limiting** conditions will override the normal leaving chilled liquid temperature control:

- Low Evaporator Pressure
- High Condenser Pressure
- High Motor Current
- Low Discharge Superheat

The Slide Valve can be manually controlled by a Service Technician from the COMPRESSOR Screen using the Keypad keys. The Slide Valve position will be shown as XXX% until the Slide valve calibration is performed by a Service Technician.

To prevent overcooling the building or process, the chiller will shutdown and display “LEAVING CHILLED LIQUID – LOW TEMPERATURE” when the Leaving Chilled Liquid Temperature decreases to < the programmed **Leaving Chilled Liquid Temperature Cycling Offset-Shutdown** setpoint. After it has shutdown, the chiller is prevented from restarting until the

Leaving Chilled Liquid Temperature has increased to > the programmed **Leaving Chilled Liquid Temperature Cycling Offset-Restart** setpoint. This prevents short cycling the chiller.

The chiller can cool **WATER** or a **BRINE** solution. Water can be cooled over a range of 38.0° to 70.0°F . If Smart Freeze protection (explained below) is enabled, the range is 36.0° to 70.0°F . Brine solution can be cooled over a range of 20.0° to 70.0°F .

Ice Storage mode is an operating mode within Brine mode that allows the chiller to make ice at a faster than normal rate by inhibiting unload pulses to the Slide Valve. Load pulses are applied until the Leaving Chilled Liquid Temperature Cycling Offset-Shutdown threshold is reached, whereupon the chiller shuts down. No unload pulses or hold outputs are applied to the Slide Valve unless any of the following Load Limit conditions exist: Low Evaporator Pressure, High Condenser Pressure, High Motor Current or Low Discharge Superheat. The chiller will automatically restart when the Ice Storage Restart threshold is exceeded. Ice storage mode is turned ON from the Evaporator Screen. After it is turned ON, Ice Storage mode is automatically Activated (inhibits unload pulses) and Deactivated (allows unload pulses) by the value programmed for the Leaving Chilled Liquid Temperature Setpoint. Values $\leq 32.0^\circ\text{F}$ Activates Ice Storage mode. Setpoint values $> 32.0^\circ\text{F}$ Deactivate Ice storage Mode. An LED on the Evaporator Screen illuminates when Ice Storage mode is Active. This allows the chiller to be switched in and out of Ice Storage mode by a Local or Remote change of this setpoint. This feature allows the chiller to make ice in the nighttime hours and perform air-conditioning duty during the daytime hours simply by changing the Leaving Chilled Liquid Temperature Setpoint. When Ice storage is turned ON, there are two different Restart Setpoints employed: One is programmed and will be in effect when the Leaving Chilled Liquid Temperature Setpoint is $\leq 32.0^\circ\text{F}$ (Ice Storage mode Active), the other is programmed and will be in effect when the setpoint is $> 32.0^\circ\text{F}$ (Ice Storage mode Not Active). Each Restart setpoint can be programmed to a different value.

To prevent nuisance shutdowns due to brief periods of chilled liquid flow fluctuations or other brief operating conditions that would normally cause Low Evaporator

Pressure safety shutdowns, the **Smart Freeze** protection feature can be enabled by a Service Technician. With this feature enabled and activated, the chiller is permitted to ride through these temporary conditions. The basis of this feature is that the chilled liquid contains a certain amount of heat that cannot be eliminated immediately. It requires a certain amount of time for solidification to occur. During this period of time, the Evaporator Refrigerant Temperature is used as one of the variables to determine when solidification will occur and an appropriate Low Evaporator Temperature shutdown threshold is applied. This threshold could be lower, but not higher than the normal Safety threshold. This feature also allows the Leaving Chilled Liquid Temperature Setpoint to be set as low as 36.0° F. If set to < 38.0° F, the Low Chilled Liquid Temperature Cycling shutdown threshold becomes a minimum of 34.0° F. After being enabled by a Service technician, Smart Freeze is activated when the leaving Chilled Liquid Temperature is set to < 38.0° F. Once activated, the total number of seconds the Evaporator Refrigerant Temperature is below the freeze threshold is counted. If this accumulated time exceeds the maximum allowed, a safety shutdown is performed and “EVAPORATOR-LOW PRESSURE-SMART FREEZE” is displayed. Smart Freeze cannot be used in Brine cooling mode. A complete description of this feature is contained in YORK Service Manual 160.80-M1.

Since liquid refrigerant is transferred from the Condenser to the Evaporator via the Condenser-Evaporator pressure differential, a large differential can create an excess refrigerant level in the evaporator. A small differential can result in insufficient level in the Evaporator. To maintain an appropriate refrigerant level in the Evaporator under all conditions, the chiller is equipped with a **Variable Orifice**. A solenoid valve, located in a line parallel with the main refrigerant orifice is opened and closed under Program control to create a variable orifice. Opening the line allows a greater refrigerant flow to the Evaporator. Closing the line decreases the flow. When the chiller is shutdown, the solenoid valve is opened during the 2 minute “SYSTEM LOCKOUT DELAY” and closed thereafter. During run, the solenoid valve is controlled per the DELTA P setpoint, programmed by a Service Technician. The DELTA P setpoint represents the system pressure differential (Condenser pressure-Evaporator pressure) and is programmed over the range of 25

to 150 PSIG (R22) or 15 to 110 PSIG (R134a). When the pressure differential is < the DELTA P setpoint, the solenoid valve is opened. When it is > 10 PSIG above the setpoint, the valve is closed. While a Low Evaporator Pressure Warning is in effect, DELTA P control is overridden and the Solenoid Valve is opened until the warning is released. Also, if the Discharge Superheat is < 15.0° (R22); <10.0° F (R134a), DELTA P control and any Low Evaporator Pressure override that is in effect is overridden and the solenoid Valve is closed until the Discharge superheat increases to $\geq 20.0^\circ$ F(R22); $\geq 15.0^\circ$ F(R134a), whereupon the Discharge Superheat Override is released. LED indicators on the VARIABLE ORIFICE CONTROL Screen illuminate when these overrides are in effect. A complete description of the Variable Orifice control is contained in YORK Service Manual 160.80-M1.

An optional **Hot Gas Bypass** system allows the chiller to remain running during extreme light load conditions by diverting hot refrigerant gas directly from the Oil Separator to the Evaporator, bypassing the Condenser. A solenoid Valve, located in the bypass line, is opened and closed under Program control to turn the hot gas on and off. When the chiller is shutdown, the Hot gas Bypass is turned off. Each time the chiller is started, it remains off for the first 3 minutes of chiller operation. Thereafter, it is controlled per the differential between the Return Chilled Liquid temperature and the Leaving Chilled Liquid Temperature Setpoint. This differential is programmed as the Hot Gas ON and Hot Gas OFF setpoints by a Service Technician. If the chiller is equipped with the Hot Gas feature, operation must be enabled by a Service technician. A complete description of the Hot Gas Bypass system is contained in YORK Service Manual 160.80-M1.

Since the chiller is not allowed to start until the Slide Valve position is <30%, it is unloaded to <30% prior to shutting down on the following routine shutdowns. The presence of oil pressure while the chiller is operating facilitates the unloading. This minimizes the time delay between starts. To assure mechanical problems cannot prevent a chiller shutdown, if the Slide Valve has not unloaded to < 30% within 210 seconds of receiving a shutdown command, a shutdown occurs, regardless of Slide Valve position.

- “Multi-Unit Cycling-Contacts Open”
- “System Cycling-Contacts Open”
- “Remote stop”
- “Leaving Chilled Liquid-Low Temperature”
- “Control Panel-Schedule”

In multiple chiller applications it may be possible for the chilled liquid (Water or Brine) from an operating chiller to flow through the Evaporator of a standby chiller. This represents a possible freeze threat to the Condenser of the standby chiller. The **Standby Chiller Freeze Protection** feature minimizes this freeze potential by allowing the OptiView Control Center of the standby chiller to cycle the Condenser Pump based on the standby chiller’s Condenser Saturation Temperature while it is shutdown. At chiller shutdown, the pump runs until the condenser saturation temperature increases to $>35.0^{\circ}\text{F}$, whereupon the pump is turned off. While the chiller is shutdown, the condenser saturation temperature is monitored. If it decreases to $< 30.0^{\circ}\text{F}$, the pump is turned on and runs until the temperature increases to $> 35.0^{\circ}\text{F}$. After the chiller has been shutdown for at least the time delay programmed as the Freeze time Setpoint, and the temperature decreases to $< 28.0^{\circ}\text{F}$, “WARNING – FREEZE THREAT FROM OPERATING CHILLER” is displayed and alarm output is activated. When the temperature increases to 28.0°F , the warning message and alarm output automatically clear. If this feature is desired, **Freeze Warning** must be enabled by a Service Technician. A complete description of this feature is contained in the YORK Service Manual 160.80-M1. An **Oil Recovery** feature is included in Flash Memory Card version C.MLM.03.03.xxx (and later). Extended operation at low load, entering condenser water temperatures that are below design, oil cooler supply problems or oil solenoid valve problems can allow oil to migrate from the oil separator to the evaporator refrigerant charge. This reduces the quantity of oil in the separator and can result in “Oil Separator – Low Level” safety shutdowns. Excess oil mixed with the refrigerant in the evaporator will cause severe foaming when the chiller is started. This foaming carries liquid refrigerant into the compressor, lowering the compressor discharge temperature. As the compressor discharge temperature approaches the condenser saturation

temperature (low discharge superheat), the refrigerant gas has a greater affinity to absorb more oil. When the discharge superheat is reduced, oil cannot be separated from the refrigerant gas in the oil separator. The Oil Recovery feature is used to automatically recover the oil that has accumulated in the evaporator refrigerant. It accomplishes this by applying load, unload or hold outputs to the slide valve in 5-second intervals according to the rate of change of the discharge superheat in each interval. This operation is detailed below. The feature can be Enabled or Disabled. The Default is Disabled. Pertinent information for this feature is displayed on the Oil Separator Screen. The change in superheat that occurs in each 5-second interval is displayed as “Change in Discharge Superheat = $xx.x^{\circ}\text{F}$ ”. Increases are displayed as $xx.x$. Decreases are displayed as $-xx.x$. The Oil recovery feature is Enabled and Disabled on this screen. This feature is used as a tool to recover oil and should only be enabled following an oil loss safety shutdown.

After a 3-minute bypass at start, during which the Separator Oil Level Switch (SOLS) status is bypassed, the Oil Recovery operation is performed as follows:

1. If the discharge superheat is $[>15.0^{\circ}\text{F}$ (R22) (10.0°F for R134a) and $<25.0^{\circ}\text{F}$ (R22) (13.0°F for R134a)] or the Slide Valve position is $< 40\%$, the superheat and superheat rate of change are evaluated every 5 seconds and the following action is taken at the end of each 5-second period. While this operation is in effect, “Warning – Oil Recovery limit” is displayed on the System Details line of the display. If the change in discharge superheat:
 - Remains the same or increases, apply 0.5 second load pulse
 - Decreases by 0.1 to 0.9°F , hold the slide valve
 - Decreases $>1^{\circ}\text{F}$, apply 0.5 second unload pulse.
2. If the discharge superheat is $<15.0^{\circ}\text{F}$ (R22) (10.0°F for R134a) but $>10^{\circ}\text{F}$ (R22) (5.0°F for R134a), hold the slide valve.
3. If the discharge superheat is $\leq 10.0^{\circ}\text{F}$ (R22) (5.0°F for R134a):
 - Inhibit loading
 - If condition exists for ≥ 10 seconds, invoke “Excess

Charge Override' routine as follows: apply 0.5 second unload pulses every 3 seconds (during which "Warning – Low Discharge Superheat Limit" is displayed) until Superheat $\geq 15.0^{\circ}\text{F}$ (whereupon "Warning-Low Discharge Superheat Detected" replaces the message "Warning – Low Discharge Superheat Limit").

4. When both the superheat increases to $\geq 25.0^{\circ}\text{F}$ (R22)(13.0 $^{\circ}\text{F}$ for R134a) and the slide valve position is $\geq 40\%$, "Warning – Oil Recovery Limit" is cleared, Oil Recovery operation terminates and normal operation resumes.

If the Oil recovery feature is Enabled, the restart criteria following an "Oil Separator – Low Level" safety shutdown is different than if the feature is Disabled. With the feature Disabled, the Separator Oil Level Switch (SOLS) must be closed before a restart is allowed. This requirement is the same as in all previous software versions. However, to eliminate the need to manually bypass the SOLS in order to restart a chiller that has already suffered oil loss, the SOLS does not have to be closed to start the chiller when the feature is Enabled.

This page intentionally left blank

SECTION 2

OPTIVIEW CONTROL CENTER

INTRODUCTION

The YORK OptiView Control Center is a microprocessor based control system for R22 or R134a screw chillers. It controls the leaving chilled liquid temperature via slide valve controls and has the ability to limit motor current via control of the slide valve. Further, it is compatible with the York Solid State Starter (optional), and electromechanical starter applications.

The panel comes configured with a full screen LCD Graphic Display mounted in the middle of a keypad interface. The graphic display allows the presentation of several operating parameters at once. In addition, the operator may view a graphical representation of the historical operation of the chiller as well as the present operation. For the novice user, the locations of various chiller parameters are clearly and intuitively marked. Instructions for specific operations are provided on many of the screens.

The graphic display also allows information to be represented in both English (temperatures in °F and pressures in PSIG) and Metric (temperatures in °C and pressures in kPa) mode. The advantages are most apparent, however, in the ability to display many languages.

The Control Center continually monitors the system operation and records the cause of any shutdowns (Safety, Cycling or Normal). This information is recorded in memory and is preserved even through a power failure condition. The user may recall it for viewing at any time. During operation, the user is continually advised of the operating conditions by various status and warning messages. In addition, it may be configured to notify the user of certain conditions via alarms. A complete listing of shutdown, status, and warning messages is attached in the **Display Messages** section of this book.

There are certain screens, displayed values, programmable Setpoints and manual control shown in this book that are for Service Technician use only. They are only

displayed when logged in at **SERVICE** access level or higher. The Setpoints and parameters displayed on these screens are explained in detail in YORK Service Manual 160.80-M1. **These parameters affect chiller operation and should NEVER be modified by anyone other than a qualified Service Technician. They are shown in this book for reference only.**

Advanced Diagnostics and troubleshooting information for Service Technicians are included in YORK Service Manual 160.80-M1. Also included in the Service manual are detailed descriptions of chiller features, such as the Refrigerant Level Control, Hot Gas Bypass, Remote Setpoints, and Smart Freeze Protection.

The control center expands the capabilities of remote control and communications. By providing a common networking protocol through the ISN, YORK Chillers not only work well individually, but also as a team. This new protocol allows increased remote control of the chiller, as well as 24-hour performance monitoring via a remote site. In addition, compatibility is maintained with the present network of ISN communications. The chiller also maintains the standard digital remote capabilities as well. Both of these remote control capabilities allow for the standard Energy Management System (EMS) interface:

1. Remote Start
2. Remote Stop
3. Remote Leaving Chilled Liquid Temperature Setpoint adjustment (0-20mA or 4-20mA, 0-10VDC or 2-10VDC) or Pulse Width Modulation
4. Remote Current Limit Setpoint adjustment (0-20mA or 4-20mA, 0-10VDC or 2-10VDC) or Pulse Width Modulation
5. Remote "Ready to Start" Contacts
6. Safety Shutdown Contacts

7. Cycling Shutdown Contacts

The chiller operating program resides in the Optiview control center Microboard. The control center could be equipped with either of the following Microboards:

- 031-01730-000 – shipped in new production chillers until March 2004. The program resides in a replaceable Flash Memory Card. The software version (C.MLM.03.xx.yzz) is printed on label adhered to card. Program can be upgraded by replacing the card.
- 031-02430-000 – shipped in new production chillers after March 2004. The program resides in non-removable onboard memory. The software version is C.OPT.03.xx.yzz, and is viewable on the DIAGNOSTICS Screen in SERVICE access level. The program can be upgraded by downloading a new program from a Program Card. Program Cards are shirt-pocket-size portable memory storage devices available from YORK.

Earlier vintage chillers could be equipped with a later Microboard due to service replacement.

Software versions (C.MLM.03.xx.yzz or C.OPT.03.xx.yzz) are alpha-numeric codes that represent the application, language package and revision levels per below. Each time the controls portion or language section is revised, the respective revision level increments.

- C – Commercial chiller
- MLM – Used on Microboard 031-01730-000
- OPT - Used on Microboard 031-02430-000
- 03 – YS chiller
- xx - controls revision level (00, 01, etc)
- y – language package (0=English only, 1=NEMA, 2=CE, 3=NEMA/CE)
- zz – language package revision level (00, 01, etc)

Throughout this book, reference is made to functions and features that are only available in certain Flash Memory Card revision levels (C.MLM.03.xx.xxx). To cross reference C.MLM software to C.OPT software, refer to the controls revision level. Software version C.OPT.03.03A.xxx is of the same controls revision level as C.MLM.03.03.xxx. From this starting point, both receive the same updates at each revision. Software upgrades should only be performed by a Service Technician.

CONTROL CENTER

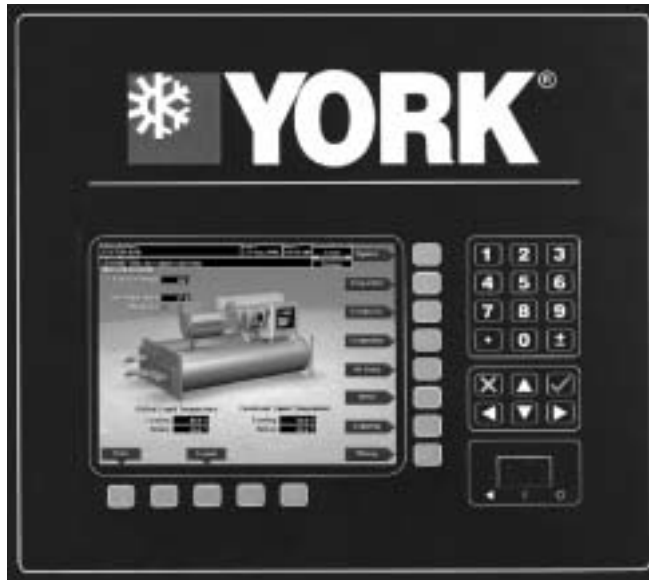





FIG. 3 - CONTROL CENTER

00245VIP

The OptiView Control Center display is highlighted by a full screen graphics display. This display is nested within a standard keypad, and is surrounded by “soft” keys which are redefined based on the currently displayed screen. Eight buttons are available on the right side of the panel, and are primarily used for navigation between the system screens. At the base of the display are 5 additional buttons. The area to the right of the keypad is used for data entry with a standard numeric keypad provided for entry of system setpoints and limits.

 The *Decimal* key provides accurate entry of setpoint values.

 A +/- key has also been provided to allow entry of negative values and AM/PM selection during time entry.

 In order to accept changes made to the chiller setpoints, the *Check* key is provided as a universal ‘Enter’ key or ‘Accept’ symbol.

 In order to reject entry of a setpoint or dismiss an entry form, the ‘X’ key is provided as a universal ‘Cancel’ symbol.

 *Cursor Arrow* keys are provided to allow movement on screens which contain a large amount of entry data. In addition, these keys can be used to scroll through history and event logs.

The Start/Stop control is operated via a three-position rocker switch. When toggled all the way to the right, it is

considered in the **STOP/RESET** position. When in the middle position, this is considered the **RUN** state. When toggled to the left-most position, it is considered in the **START** state. Each state is described in detail below:

- **STOP / RESET (O)**

When in this position, the chiller will not run under any condition. For safety reasons, this position is required for many maintenance tasks to be completed. In addition, the switch must be placed in this state following a Safety shutdown before the chiller is allowed to restart. This guarantees that manual intervention has taken place and the shutdown has been acknowledged.

- **START (◀)**

The switch can only remain in this position when being acted upon by a manual force. Once the user has released the switch, it automatically reverts to the RUN position. Generally, this state only occurs momentarily as the operator attempts to locally start the unit. Once this position has been sensed, if all fault conditions are cleared, the unit will enter the “Start Sequence Initiated” cycle.

- **RUN (■)**

When in this position, the chiller is able to operate. The switch spring-returns to this state after it has been toggled to the **START** position. When in this state, the chiller is allowed to function normally, and will also allow the chiller to automatically restart following a Cycling shutdown. The switch must be in this state to receive a valid remote start signal when operating under a remote control source.

INTERFACE CONVENTIONS

OVERVIEW

The new graphical display on each control panel allows a wide variety of information to be presented to the user. Each screen description in this document will begin with a section entitled **Overview** which will describe the graphical elements on the screen and give a short summary of the functions available. Each element on the screen will then be categorized into three distinct groups: Display Only, Programmable, and Navigation. Below is a short description of what types of information are included in these groups.

The Programmable values and Navigation commands are also subject to access level restrictions as described below. For each of these elements, an indication is given to show the minimum access level required to program the value or navigate to the sub-screen.

DISPLAY ONLY

Values in this group are read-only parameters of information about the chiller operation. This type of information may be represented by a numerical value, a text string, or an LED image. For numerical values, if the monitored parameter is above the normal operating range, the high limit value will be displayed along with the '>' symbol; if it is below the normal operating range, the low limit value will be displayed along with the '<' symbol. In some cases, the value may be rendered invalid by other conditions and the display will use X's to indicate this.

PROGRAMMABLE

Values in this group are available for change by the user. In order to program any setpoints on the system, the user must first be logged in with the appropriate access level. Each of the programmable values requires a specific Access Level which will be indicated beside the specified value. All of the programmable controls in the system fall into one of the categories described below:

Access Level

In order to program any setpoints on the system, the user must first login with an appropriate access level. When power is applied to the chiller, the system begins with an Access Level of **VIEW**. This will allow the user to navi-

gate to most screens and observe the values displayed there. However, the user will not be allowed to change any values. To change any values, the user must return to the **Home Screen** (shown by default when power is applied to the system), and use the **LOGIN** button or utilize the **CHANGE SETPOINTS** key described below. At this point, the user will be prompted to enter a User ID and the corresponding Password. By default, the User ID is zero (0). In order to gain standard **OPERATOR** level access, the Password would be entered as **9 6 7 5**, using the numeric keypad. **OPERATOR** access reverts to the **VIEW** level after 10 continuous minutes without a keypress. If a custom User ID and Password have been defined (see User Screen), the user may enter that User ID and the corresponding Password value.

If the correct password is received, the user is authorized with the appropriate Access Level. If an incorrect password is entered, the user is notified of the failure and prompted again. At this point the user may retry the password entry, or cancel the login attempt.

Change Setpoints

On screens containing setpoints programmable at the **OPERATOR** access level, a key with this label will be visible if the present access level is **VIEW**. This key brings up the Access Level prompt described above. It allows the user to login at a higher Access Level without returning to the Home Screen. After login, the user may then modify setpoints on that screen.

Setpoints

The control center uses the setpoint values to control the chiller and other devices connected to the chiller system. Setpoints can fall into several categories. They could be numeric values (such as 45.0°F (7°C) for the Leaving Chilled Liquid Temperature), or they could Enable or Disable a feature or function.

Regardless of which setpoint is being programmed, the following procedure applies:

1. Press the desired setpoint key. A dialog box appears displaying the present value, the upper and lower limits of the programmable range, and the default value.
2. If the dialog box begins with the word "ENTER", use the numeric keys to enter the desired value.

Leading zeroes are not necessary. If a decimal point is necessary, press the ‘.’ key (i.e. 45.0).

Pressing the ▲ key, sets the entry value to the default for that setpoint. Pressing the ▼ key, clears the present entry. The ◀ key is a backspace key and causes the entry point to move back one space.

If the dialog box begins with “SELECT”, use the ◀ and ▶ keys to select the desired value.

If the previously defined setpoint is desired, press the ‘X’ (Cancel) key to dismiss the dialog box.

3. Press the ‘✓’ (Enter) key.

If the value is within range, it is accepted and the dialog box disappears. The chiller will begin to operate based on the new programmed value. If out of range, the value will not be accepted and the user is prompted to try again.

Manual Controls

Some keys are used to perform manual control functions. These may involve manual control of items such as the slide valve. Other keys in this category are used to initiate/terminate processes such as calibrations or reports.

Free Cursor

On screens containing many setpoints, a specific “soft” key may not be assigned to each setpoint value. A soft key will be assigned to enable the cursor arrow keys below the numeric keypad which are used to “highlight” the desired setpoint field. At this point, the ‘T’ key is pressed to bring up a dialog prompting the user to enter a new setpoint value. The ‘X’ key cancels cursor mode. (See the Schedule Screen for an example.)

NAVIGATION

In order to maximize the amount of values which the panel can display to the user, and in order to place those values in context, multiple screens have been designed to describe the chiller operation. In order to move from one screen to the next, navigation keys have been defined. These keys allow the user to either move “forward” to a sub-screen of the present screen, or move “backward” to the previous screen. Except for the Home Screen display, the upper-right “soft” key will always return the user to the Home Screen. Navigating with “soft” keys is as simple as pressing the key next to the label containing the name of the desired screen. The system will immediately refresh the display with the graphics for that screen. Following is a layout of all the screens and how they are connected.

Home Screen (page 22)

- └ System Screen (page 24)
- └ Evaporator (page 26)
 - └ Condenser (page 30)
 - └ Variable Orifice (page 32)
 - └ Compressor (page 34)
 - └ Hot Gas Bypass (page 36)
 - └ Slide Valve Calibration (page 38)
- └ Oil Sump (Separator) (page 40)
- └ Motor (page 42)
 - └ EM Starter Version (page 42)
 - └ Mod “A” Solid State Starter (page 44)
 - └ Mod “B” Solid State Starter (page 46)
- └ Setpoints (page 48)
 - └ Setup (page 50)
 - └ Schedule (page 52)
 - └ User (page 54)
 - └ Comms (page 55)
 - └ Printer (page 56)
 - └ Sales Order (page 57)
 - └ Operations (page 58)
 - └ Diagnostics (*Refer to YORK Service Manual 160.80-M1*)
- └ History (page 60)
 - └ History Details (page 62)
 - └ Trend (page 68)
 - └ Trend Setup (page 70)
 - └ Advanced Trend Setup (page 72)
 - └ Common Slots (page 74)
 - └ Custom View (page 65)
 - └ Custom View Setup (page 65)
 - └ Security Log (page 63)
 - └ Security Log Details (page 64)

LANGUAGES

The Screens can be displayed in various languages. Language selection is done on the USER Screen. The desired language is selected from those available. Not all languages are available. English is the default language. If a language other than English is being displayed, an

English-only speaking person should navigate to the USER Screen using the preceding Navigation chart and select English per the USER Screen instructions in this book.

2

ANALOG INPUT RANGES

The following table indicates the valid display range for each of the analog input values. In the event that the input sensor is reading a value outside of these ranges, the < or > symbols will be displayed beside the minimum or maximum value, respectively.

ANALOG INPUT	ENGLISH RANGE			METRIC RANGE		
	LOW	HIGH	UNITS	LOW	HIGH	UNITS
Leaving Chilled Liquid Temperature	0.0	82.0	°F	-17.7	27.7	°C
Return Chilled Liquid Temperature	0.0	94.1	°F	-17.7	34.5	°C
Leaving Condenser Liquid Temperature	8.0	133.5	°F	-13.3	56.3	°C
Return Condenser Liquid Temperature	8.0	133.5	°F	-13.3	56.3	°C
Evaporator Refrigerant Temperature (Optional)	0.0	126.1	°F	-17.7	52.3	°C
Discharge Temperature	31.8	226.3	°F	-0.1	107.9	°C
Oil Temperature	31.8	226.3	°F	-0.1	107.9	°C
Condenser Pressure (R22 and R134a)	0.0	315.0	PSIG	0.0	2172.4	KPAG
Condenser Temperature (R22)*	-122.1	130.9	°F	-85.6	54.9	°C
Condenser Temperature (R134a)*	-98.7	160.1	°F	-72.6	71.7	°C
Evaporator Pressure (R22 – water)	49.4	128.8	PSIG	340.6	888.2	KPAG
Evaporator Pressure (R22 – brine)	25.0	100.0	PSIG	172.4	689.6	KPAG
Evaporator Pressure (R134a)	5.5	77.4	PSIG	37.9	533.7	KPAG
Evaporator Temperature (R22 – water)*	13.0	67.0	°F	-10.5	19.4	°C
Evaporator Temperature (R22 – brine)*	-18.0	51.4	°F	-27.7	10.7	°C
Evaporator Temperature (R134a)*	-44.9	64.7	°F	-42.7	18.1	°C
Oil Pressure (R22)	23.2	271.8	PSIG	160.0	1874.4	KPAG
Oil Pressure (R134a)	0.0	315.0	PSIG	0.0	2172.4	KPAG
Filter Oil Pressure (R22 and R134a)	0.0	315.0	PSIG	0.0	2172.4	KPAG
Seal Oil Pressure (R22 and R134a)	0.0	315.0	PSIG	0.0	2172.4	KPAG

*Saturation temperatures are calculated values. They will display XXX if the pressure used for the calculation is out of range.

HOME SCREEN



FIG. 4 - HOME SCREEN

00218VIP

OVERVIEW

When the chiller system is powered on, the above default display appears. The primary values which must be monitored and controlled are shown on this screen. The Home Screen display depicts a visual representation of the chiller itself. Animation indicates chilled liquid flow.

DISPLAY ONLY**Chilled Liquid Temperature - Leaving**

Displays the temperature of the liquid as it leaves the evaporator.

Chilled Liquid Temperature - Return

Displays the temperature of the liquid as it enters the evaporator.

Condenser Liquid Temperature - Leaving

Displays the temperature of the liquid as it leaves the condenser.

Condenser Liquid Temperature - Return

Displays the temperature of the liquid as it enters the condenser.

Motor Run (LED)

Is **ON** when the digital output controlling the Motor Starter contact is on.

% Full Load Amps

This displays the percentage of full load amps utilized by the system.

Operating Hours

Displays the cumulative operating hours of the chiller.

PROGRAMMABLE**Login**

Access Level Required: VIEW

The Control Center restricts certain operations based on password entry by the operator. Three different access levels are provided as follows: **VIEW**: The panel defaults to the lowest access level which is termed **VIEW**. In this mode, the chiller operating values and setpoints can be observed, but no changes can be made. **OPERATOR**: The second access level is termed **OPERATOR** and will allow the customer to change all of the setpoints required to operate the chiller system. The **OPERATOR** access level reverts to the **VIEW** level after 10 continuous minutes without a keypress. **SERVICE**: In the event that advanced diagnostics are necessary, a **SERVICE** access level has been provided. Only qualified service personnel utilize this access level. This level provides advanced control over many of the chiller functions and allows calibration of many of the chiller controls. The access levels are listed above in hierarchical order beginning with the lowest level and proceeding to the highest level. Users logged in under

higher access levels may perform any actions permitted by lower access levels.

The **OPERATOR** access level is accompanied by a 10-minute time-out. After ten (10) successive minutes without a keypress, the panel will revert to the **VIEW** access level. This prevents unauthorized changes to the chiller if a user was logged in at a higher access level and failed to logout. Proper procedure requires that after making necessary setpoint adjustments the user return to the Home Screen and logout.

Logout

Access Level Required: OPERATOR

This key is displayed when a user is logged in at any level other than **VIEW**. Pressing it will return the access level to **VIEW**.

Print

Access Level Required: VIEW

Use this key to generate a hard-copy report of the present system status. This provides a snapshot of the primary operating conditions at the time the key is pressed. The History page provides enhanced reporting capability. (See HISTORY below.)

Message Clear

Access Level Required: SERVICE

When certain safety or cycling conditions have been detected and the chiller has been shutdown, the main status display of the chiller will continue to display a message indicating the cause of the shutdown. Using this key, the message can be cleared once the condition has been removed.

Warning Reset

Access Level Required: OPERATOR

Use of this key acknowledges a warning condition and resets the message display associated with it.

NAVIGATION

System

Used to provide additional system information.

Evaporator

A detailed view of all evaporator parameters, including the programmable Leaving Chilled Liquid Setpoints.

Condenser

A detailed view of all condenser parameters.

Compressor

A detailed view of all the compressor parameters. This includes slide valve control, and Hot Gas Bypass Control and slide valve calibration.

Oil Sump

A detailed view of all the oil sump parameters. This includes the Seal Lubrication functionality.

Motor

A detailed view of the motor controller parameters, specific to the controller type presently utilized on the chiller system. This allows programming of the Current Limit and the Pulldown Demand Limit values.

Setpoints

This screen provides a single location to program the most common system setpoints. It is also the gateway to many of the general system setup parameters such as Date/Time, Display Units, Scheduling, Printer Setup, etc.

History

This screen provides access to a snapshot of system data at each of the last 10 shutdown conditions.

SYSTEM SCREEN

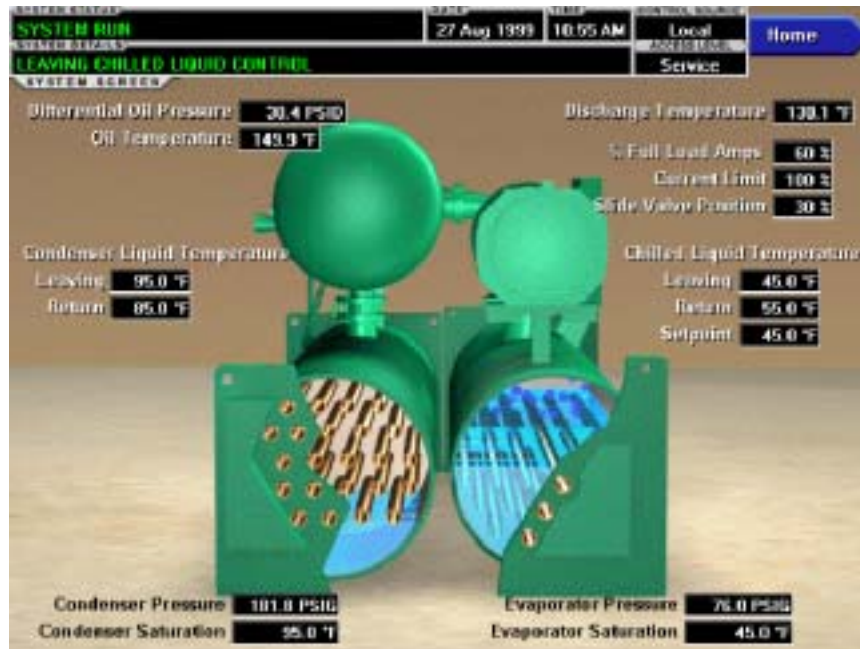

FIG. 5 - SYSTEM SCREEN

00219VIP

OVERVIEW

This screen gives a general overview of common chiller parameters for both shells.

DISPLAY ONLY

Discharge Temperature

Displays the temperature of the refrigerant in its gaseous state at discharge of the compressor as it travels to the condenser.

Chilled Liquid Temperature - Leaving

Displays the temperature of the liquid as it leaves the evaporator.

Chilled Liquid Temperature - Return

Displays the temperature of the liquid as it enters the evaporator.

Chilled Liquid Temperature - Setpoint

Displays the active temperature setpoint to which the chiller is controlling the evaporator liquid. This value could come from a 0-20mA or 4-20 mA, 0-10VDC or 2-10VDC input in Analog Remote mode, PWM signal in Digital Remote mode, ISN/Microgateway interface in ISN mode, or a locally programmed value in local mode.

Evaporator Pressure

Displays the present refrigerant pressure in the evaporator.

Evaporator Saturation Temperature

Displays the present saturation temperature in the evaporator.

Condenser Liquid Temperature - Leaving

Displays the temperature of the liquid as it leaves the condenser.

Condenser Liquid Temperature - Return

Displays the temperature of the liquid as it enters the condenser.

Condenser Pressure

Displays the refrigerant pressure in the condenser.

Condenser Saturation Temperature

Displays the saturation temperature in the condenser.

Oil Temperature

Displays the temperature of the oil in the separator (sump).

Differential Oil Pressure

Displays the pressure differential between the oil pressure transducer (input to the compressor) and the evaporator pressure transducer. The displayed value includes offset pressure derived from auto-zeroing during the START SEQUENCE INITIATED. If either of the transducers used to calculate this differential is out of range, the display field will show XX.X.

% Full Load Amps

This displays the percentage of full load amps utilized by the system.

Current Limit

Displays the current limit value in use. This value could come from a 0-20mA or 4-20 mA, 0-10VDC or 2-10VDC input in Analog Remote mode, PWM signal

in Digital Remote mode, ISN/Microgateway interface in ISN mode, or a locally programmed value.

Slide Valve Position

The value displayed represents the position of the slide valve relative to fully closed at 0% and fully open at 100%.

PROGRAMMABLE

None

NAVIGATION**Home**

Access Level Required: VIEW

Causes an instant return to the Home Screen.

EVAPORATOR SCREEN



FIG. 6 - EVAPORATOR SCREEN

00220VIP

OVERVIEW

This screen displays a cutaway view of the chiller evaporator. All setpoints relating to the evaporator side of the chiller are maintained on this screen. Animation of the evaporation process indicates whether the chiller is presently in a **RUN** condition. Animation of the liquid flow indicates chilled liquid flow.

DISPLAY ONLY

Chilled Liquid Flow Switch (Open / Closed)

Displays whether the liquid flow is present in the evaporator.

Chilled Liquid Pump

Displays the command presently sent by the control center to the Chilled Liquid Pump (**RUN** or **STOP**).

Evaporator Pressure

Displays the present refrigerant pressure in the evaporator.

Evaporator Saturation Temperature

Displays the present saturation temperature in the evaporator.

Return Chilled Liquid Temperature

Displays the temperature of the liquid as it enters the evaporator.

Leaving Chilled Liquid Temperature

Displays the temperature of the liquid as it leaves the evaporator.

Evaporator Refrigerant Temperature

Displays the temperature of the refrigerant in the evaporator, if the sensor is present.

Small Temperature Difference

Displays the difference between the Leaving Chilled Liquid temperature and the Evaporator Refrigerant temperature. The Evaporator Refrigerant temperature will be represented by the Refrigerant Temperature sensor input if the sensor is present and enabled, otherwise it will be represented by the Evaporator Saturation temperature.

Leaving Chilled Liquid Temperature Setpoints – Setpoint

Displays the present setpoint to which the chiller is operating, whether controlled locally or remotely. This value could come from a 0-20mA or 4-20 mA, 0-10VDC or 2-10VDC input in Analog Remote mode, PWM signal in Digital Remote mode, ISN/Microgateway interface in ISN mode, or a locally programmed value in local mode. This setpoint is in effect for either WATER, BRINE or BRINE/ICE storage operation. In water cooling or brine cooling mode the slide valve is modulated to achieve this setpoint. In brine/ice storage mode, unload pulses

are inhibited, allowing the chiller to make ice at a faster rate as explained in the “Operation” section. The water cooling setpoint range is 38°F to 70°F. The brine cooling setpoint range is 20°F to 70°F and the default is 45°F. When in brine mode and Ice Storage mode is on, it is automatically activated and deactivated by the setpoint that is entered: 20°F to 32°F activates ice storage mode, > 32°F to 70°F deactivates ice storage mode. This allows the chiller to be switched in and out of ice storage mode (when in brine mode and ice storage is on) by locally or remotely changing this setpoint.

Leaving Chilled Liquid Temperature Setpoints – Remote Range

Displays the present maximum range above the Leaving Chilled Liquid temperature setpoint that this setpoint can be remotely changed to. This is the Local Leaving Chilled Liquid Temperature - Range setpoint (See the description in the following section of programmable setpoints).

Leaving Chilled Liquid Temperature Setpoints - Shutdown

Displays the Leaving Chilled Liquid Temperature at which the chiller will shut down to avoid over-cooling the building. By default this value is 4°F below the Leaving Chilled Setpoint. The displayed value is the difference between the present Leaving Chilled Liquid Temperature setpoint and the setpoint entered for the Leaving Chilled Liquid Temperature Cycling Offset - Shutdown.

Leaving Chilled Liquid Temperature Setpoints – Shutdown Offset

Displays the offset below the Leaving Chilled Liquid Temperature setpoint at which the chiller will shutdown to avoid over-cooling. This is the Leaving Chilled Liquid Temperature Cycling - Shutdown setpoint (See the description in the following section of programmable setpoints).

Leaving Chilled Liquid Temperature Setpoints – Restart

Displays the Leaving Chilled Liquid Temperature at which the chiller will restart after it has shut down to avoid over-cooling. By default, the chiller will restart at the Leaving Chilled Liquid Temperature Setpoint. The displayed value is the difference between the present Leaving Chilled Liquid Temperature setpoint and the setpoint entered for the Leaving Chilled Liquid Temperature Cycling Offset - Restart. If Ice Storage is On and the Leaving Chilled Liquid Temperature Setpoint is $\leq 32.0^\circ\text{F}$, the Restart Temperature is the value programmed as the Ice Storage Restart Temperature.

Leaving Chilled Liquid Temperature Setpoints – Restart Offset

Displays the offset above the Leaving Chilled Liquid Temperature setpoint at which the chiller will restart after it has shut down to avoid over-cooling. This is the Leaving Chilled Liquid Temperature Cycling - Restart setpoint (See the description in the following section of programmable setpoints). If Ice Storage is On and the Leaving Chilled Liquid Temperature Setpoint is $\leq 32.0^\circ\text{F}$, the Restart Offset is the value programmed as the Ice Storage Restart Offset.

Ice Storage Active (LED)

Illuminates when Ice Storage mode is active. It is active when Ice Storage mode has been turned ON and the Leaving Chilled Liquid Temperature Setpoint is set to $\leq 32.0^\circ\text{F}$. Extinguished when Ice Storage mode is turned ON but not Active. It is not active when the Leaving Chilled Liquid Temperature Setpoint is $> 32.0^\circ\text{F}$. If Ice Storage mode is turned OFF, this indicator is not displayed.

PROGRAMMABLE

Local Leaving Chilled Liquid Temperature - Range *Access Level Required:* OPERATOR

This is the range over which an analog (0-20mA, 4-20mA, 0-10VDC or 2-10VDC) in Analog Remote mode or a digital signal (PWM) in Digital Remote mode can reset the Leaving Chilled Liquid Temperature setpoint above the operator programmed **Base** Setpoint (see below). Programmable as either 10, 20, 30, or 40°F, with a default of 10°F, it is added to the **Base** value to create a range over which the remote device can reset the setpoint. For example, if this setpoint is programmed for 10°F and the operator programmed value is 45°F, then the remote device can set the Leaving Chilled Liquid Temperature setpoint over the range 45.0° - 55.0°F.

Local Leaving Chilled Liquid Temperature - Setpoint

Access Level Required: OPERATOR

This value allows the user to define the Leaving Chilled Liquid Temperature that is to be maintained by the chiller. It is programmable over the range of 38.0°F to 70.0°F (water) or 20.0°F to 70.0°F (brine). (Micro Board Program Jumper J35 must be removed for Brine cooling applications). If Smart Freeze (see below) is enabled, the range is 36.0°F to 70.0°F (water). If Ice Storage is ON and wanted, the range is 20°F to 32°F (brine). A remote device can provide an analog signal (0-20mA, 4-20mA, 0-10VDC or 2-10VDC) in Analog

Remote mode, or PWM signal in Digital Remote mode that changes the setpoint by creating an offset above this base or lowest setting allowed for the Leaving Chilled Liquid Temperature setpoint. This offset may be defined up to 10, 20, 30, or 40°F above this base setpoint (see the Remote Leaving Chilled Liquid Temperature Setpoint Range description above). Additionally, a remote Microgateway device (in ISN Remote mode) can define the setpoint through a serial data stream. In this case, the incoming setpoint is not an offset that is applied to this locally programmed **Base** setpoint value, but rather is the setpoint value itself.

Leaving Chilled Liquid Temperature Cycling Offset - Shutdown

Access Level Required: OPERATOR

This value allows the user to specify the Leaving Chilled Liquid Temperature at which the chiller will shut down on a **LEAVING CHILLED LIQUID – LOW TEMPERATURE** cycling shutdown. This is done by defining an offset below the Leaving Chilled Liquid Temperature setpoint. It is programmable over a range of 1°F to 64°F below the setpoint, to a minimum cutout of 36°F (water), 34°F (water with Smart Freeze enabled) or 16°F (brine). It establishes the minimum allowable temperature for the Leaving Chilled Liquid Temperature and prevents over-cooling of the building. Anytime the Leaving Chilled Liquid Temperature setpoint is increased, the shutdown threshold is 36.0°F (water) or 16.0°F (brine) for the next ten (10) minutes. If Smart Freeze (see below) is enabled, the threshold is 34.0°F for the next 10 minutes. After ten (10) minutes have elapsed, the shutdown threshold becomes the programmed setpoint value.

Leaving Chilled Liquid Temperature Cycling Offset - Restart

Access Level Required: OPERATOR

This value allows the user to specify the Leaving Chilled Liquid Temperature at which the chiller will restart after a shutdown on a **LEAVING CHILLED LIQUID – LOW TEMPERATURE** cycling shutdown. This is done by defining an offset above the Leaving Chilled Liquid Temperature setpoint. It is programmable over a range of 0°F to 60°F above the setpoint, to a maximum restart value of 80°F. If Ice Storage mode is ON, there are two different RESTART Setpoints employed: One is programmed and will be in effect when the Leaving Chilled Liquid Temperature Setpoint is $\leq 32.0^\circ$ F. The other is programmed and will be in effect when the

Setpoint is $> 32.0^\circ$ F. Each can be programmed to a different value.

The chiller will automatically restart when this temperature is reached. This setpoint can be used to reduce chiller cycling by delaying the chiller restart until the cooling load has increased.

Brine Low Evaporator Cutout

Access Level Required: SERVICE

This value is only available in Brine mode. It allows the user to specify the Evaporator Pressure at which a safety shutdown is initiated. Service Technicians refer to YORK Service Manual 160.80-M1.

Sensitivity

Access Level Required: SERVICE

This value allows the user to adjust the sensitivity of the Leaving Chilled Liquid Temperature control. Service Technicians refer to YORK Service Manual 160.80-M1.

Ice Storage (On / Off)

Access Level Required: SERVICE

When in Brine Mode this must be turned on or off via this toggle and then the Leaving Chilled Liquid Temperature setpoint is used to automatically activate or deactivate Ice Storage Mode. Service Technicians refer to YORK Service Manual 160.80-M1.

Smart Freeze (Off / On)

Access Level Required: SERVICE

This value is only available if the chiller is not in Brine mode. It allows the user to enable the Smart Freeze Point Operation which allows the chiller to run closer to the freeze point without shutting down. Service Technicians refer to YORK Service Manual 160.80-M1.

Refrigerant (Enabled / Disabled)

Access Level Required: SERVICE

When an Evaporator Refrigerant Sensor has been installed it must be enabled via this toggle before the system will utilize the new, enhanced resolution input. Service Technicians refer to YORK Service Manual 160.80-M1.

NAVIGATION

Home

Access Level Required: VIEW

Causes an instant return to the Home Screen.

This page intentionally left blank

CONDENSER SCREEN

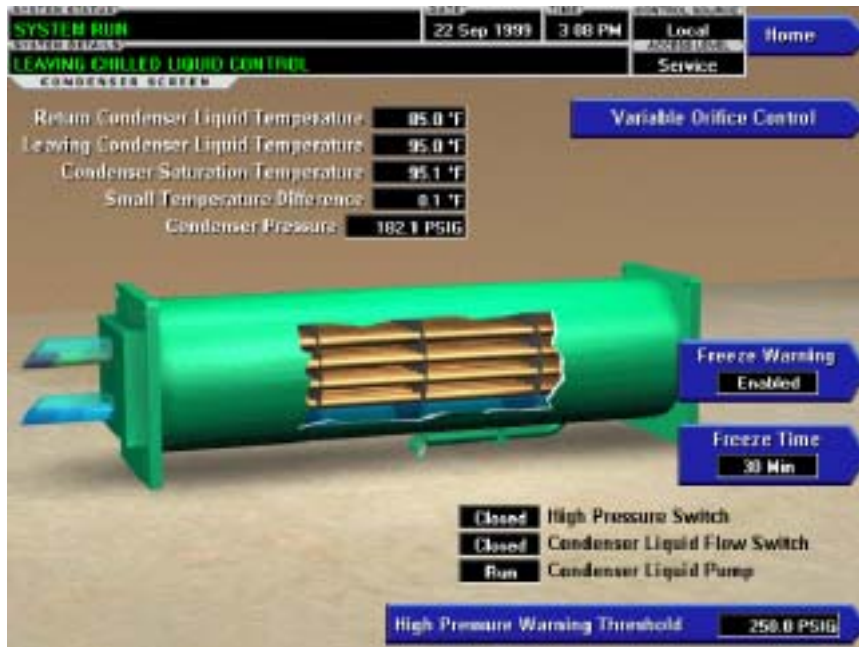

FIG. 7 - CONDENSER SCREEN

00221VIP

OVERVIEW

This screen displays a cutaway view of the chiller condenser. All setpoints relating to the condenser side of the chiller are maintained on this screen. Animation indicates condenser liquid flow. This screen also serves as a gateway to controlling the Refrigerant Level.

DISPLAY ONLY

Leaving Condenser Liquid Temperature

Displays the water temperature as it leaves the condenser.

Return Condenser Liquid Temperature

Displays the water temperature as it enters the condenser.

Condenser Pressure

Displays the refrigerant pressure in the condenser.

Condenser Saturation Temperature

Displays the saturation temperature in the condenser.

Small Temperature Difference

Displays the difference between the Condenser Refrigerant temperature and the Leaving Condenser Liquid temperature. The Condenser Refrigerant temperature will be represented by the Condenser Saturation temperature.

High Pressure Switch (Open / Closed)

Displays the present position of the high pressure switch. This will indicate whether a High Pressure fault is present.

Condenser Liquid Flow Switch

Indicates whether flow is present in the condenser.

Condenser Liquid Pump (Run / Stop)

Indicates whether Condenser liquid pump is operating.

PROGRAMMABLE

High Pressure Warning Threshold

Access Level Required: SERVICE

This value allows the user to define the condenser pressure at which the chiller will initiate a warning.

Freeze Warning (Enabled / Disabled)

Access Level Required: SERVICE

Enables and disables the standby chiller freeze protection feature. Service Technicians refer to York Service Manual 160.80-M1.

Freeze Time

Access Level Required: SERVICE

Only displayed if Freeze Warning feature is Enabled. Allows the user to define the Freeze Warning bypass time (30 to 60 minutes). Standby chiller Freeze warnings are

bypassed until the standby chiller has been shutdown for at least this amount of time. Service technicians refer to YORK Service Manual 160.80-M1

NAVIGATION

Home

Access Level Required: VIEW

Causes an instant return to the Home Screen.

Variable Orifice Control

Access Level Required: SERVICE

Moves to the Refrigerant Level sub-screen allowing programming of the refrigerant liquid level control setpoints.

VARIABLE ORIFICE CONTROL SCREEN

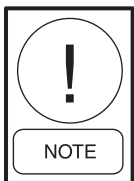

FIG. 8 - VARIABLE ORIFICE CONTROL SCREEN

00222VIP

OVERVIEW

This screen, accessed from the CONDENSER Screen in SERVICE access level, displays all of the applicable Variable Orifice control parameters and allows a Service technician to program the DELTA P Setpoint. The Low Evaporator Pressure and Superheat Override LED's are located on this screen. A view of the liquid flow piping to the chiller condenser, along with the solenoid flow control valve is shown. A solenoid valve located in a line parallel with the refrigerant orifice, is opened and closed to create a variable orifice. Opening the parallel line allows a greater refrigerant flow to the evaporator. Under Program control, it is energized to open the parallel line and de-energized to close the parallel line. During run, the Solenoid Valve is primarily controlled by DELTA P control. However, Low Evaporator Pressure and Discharge Superheat conditions can override DELTA P control as explained below.



Requires a login access level of SERVICE. Service Technicians refer to YORK Service Manual 160.80-M1 for operation instructions and explanation of all programmable setpoints and displayed values.

DISPLAY ONLY

Condenser Pressure

Displays the refrigerant pressure in the condenser.

Evaporator Pressure

Displays the present refrigerant pressure in the evaporator.

Delta P (Condenser-Evaporator)

This is the differential between the condenser and evaporator pressure calculated as $\Delta P = \text{condenser pressure} - \text{evaporator pressure}$. This value is compared to the Delta P setpoint. If this system Delta P decreases to \leq the Delta P setpoint, the solenoid valve is opened. It will remain open until the system Delta P increases to ($\Delta P \text{ setpoint} + 10$); whereupon it will close.

Discharge Temperature

Displays the temperature of the refrigerant in its gaseous state at discharge of the compressor as it travels to the condenser.

Condenser Saturation Temperature

Displays the saturation temperature in the condenser.

Superheat Temperature

Displays the difference between the discharge temperature and the condenser saturated temperature

Low Evaporator Override (LED)

If the evaporator pressure decreases to the Low Evaporator Pressure Warning threshold of 56.2 PSIG (R22) or 27.0 PSIG (R134a), DELTA P control is overridden and the solenoid valve is opened. While this condition is in effect, “WARNING - EVAPORATOR – LOW PRESSURE LIMIT” is displayed and this **Low Evaporator Pressure Override LED** is illuminated. The solenoid will remain open until the Low Pressure limit condition is no longer in effect (≥ 57.5 PSIG R22; ≥ 28.0 PSIG R134a), whereupon the Low Pressure override is released.

Superheat Override (LED)

If the Discharge Superheat (Discharge temp – Condenser Saturation temp) is $< 15.0^\circ$ F (R22) or $< 10.0^\circ$ F (R134a), DELTA P control or any Low Evaporator Pressure override (as explained above) that is in effect is overridden and the solenoid valve is closed. While this condition is in effect, the **Superheat Override LED** is illuminated. The solenoid valve will remain closed until the Discharge Superheat increases to $\geq 20.0^\circ$ F (R22) or $\geq 15.0^\circ$ F (R134a), whereupon the Discharge Superheat override is released.

PROGRAMMABLE**Delta P Setpoint**

During run, the solenoid valve is opened and closed per the **DELTA P** Setpoint that has been programmed by a qualified Service Technician. The setpoint is programmed over the range of 25 to 150 PSIG (R22) or 15 to 110 PSIG (R134a). Service Technicians refer to YORK Service Manual 160.80-M1.

NAVIGATION**Home**

Access Level Required: VIEW

Causes an instant return to the Home Screen.

Condenser

Access Level Required: VIEW

Return to the Condenser Screen.

COMPRESSOR SCREEN



FIG. 9 - COMPRESSOR SCREEN

00223VIP

OVERVIEW

This screen displays a cutaway view of the chiller compressor, revealing the rotary screw, and shows all conditions associated with the compressor. The slide valve positioning is animated and with the proper Access Level it can be manually controlled. Animation of the compressor rotors indicates whether the chiller is presently in a **RUN** condition. This screen also serves as a gateway to sub-screens for calibrating the slide valve or configuring the optional Hot Gas Bypass.

DISPLAY ONLY

Differential Oil Pressure

Displays the pressure differential between the oil pressure transducer (input to the compressor) and the evaporator pressure transducer. The displayed value includes the offset pressure derived from auto-zeroing during the START SEQUENCE INITIATED. If either of the transducers used to calculate this differential is out of range, the display field will show XX.X.

Differential Oil Pressure = (Oil Pressure - Evaporator Pressure) ± Offset Pressure

The Offset Pressure is used to calculate the differential pressure. The Offset Pressure is the pressure differential between the oil pressure transducer and the evaporator

pressure transducer during the first 15 seconds of START SEQUENCE INITIATED. This is the transducer auto-zeroing. During this time the transducers will be sensing the same pressure and their outputs should be equal. However, due to accuracy tolerances in transducer design, differences can exist. Therefore, to compensate for differences between transducers and assure differential pressure sensing accuracy, the Offset Pressure is subtracted from or added to the differential pressure. (Certain operating conditions could require the auto-zeroing to be disabled. This must never be done by anyone other than a qualified service technician). The offset pressure calculation will not be performed if either transducer is out of range. The offset value will be taken as 0 PSI in this instance.

Oil Temperature

Displays the temperature of the oil in the sump.

Discharge Temperature

Displays the temperature of the refrigerant in its gaseous state at discharge of the compressor as it travels to the condenser.

Discharge Superheat

Displays the temperature differential between the Discharge Temperature and the Condenser Saturation Temperature.

Slide Valve Position

The value displayed represents the position of the slide valve relative to fully closed at 0% and fully open at 100%.

Oil Return Solenoid (LED)

Indicates whether the solenoid is presently energized.

Full Load Amps (Electromechanical Starter only)

Access Level Required: SERVICE

Displays the motor current as a percentage of the Full Load Amps (FLA) value.

Phase A, B, C Current (Solid State Starter only)

Access Level Required: SERVICE

Displays the 3-phase motor current values being read from the Solid State Starter.

PROGRAMMABLE**[Slide Valve] Load (Manual)**

Access Level Required: SERVICE

This key puts the slide valve control into manual mode and loads the slide valve. The slide valve will continue to load until the Unload, Hold, or Auto key is pressed.

[Slide Valve] Hold (Manual)

Access Level Required: SERVICE

This key puts the slide valve control into manual mode and holds the slide valve in its present position. The slide valve will remain at this position until the Load, Unload, or Auto key is pressed.

[Slide Valve] Unload (Manual)

This key puts the slide valve control into manual mode and unloads the slide valve. The slide valve will continue to unload until the Load, Hold, or Auto key is pressed.

[Slide Valve] Auto

Access Level Required: SERVICE

This key puts the slide valve control into automatic mode.

Maximum Load Temperature

Access Level Required: SERVICE

Allows a Service Technician to specify a special Load Limit for use in certain applications. Service Technicians refer to YORK Service Manual 160.80-M1.

Maximum Load FLA

Access Level Required: SERVICE

This setpoint is used in conjunction with the above “Maximum Load Temperature” setpoint. Service Technicians refer to YORK Service Manual 160.80-M1.

Minimum Load Control Source

Access Level Required: SERVICE

The **Minimum Load Control** feature prevents the Slide Valve from unloading to a position that will not allow sufficient oil transfer to the Oil Separator while

the chiller is running. If the Slide valve is permitted to unload too far, there will not be enough oil transfer to the Oil Separator and a “Oil Separator – Low Level” Safety shutdown will result. There are two selectable control sources that can be used to set the minimum allowed Slide Valve position:

- a. **Slide Valve** – This method limits the minimum Slide Valve position to 15% (based on the position feedback potentiometer) after the chiller has been running for 3 minutes. When the Slide Valve unloads to 15%, no more unload pulses will be applied. If it decreases to < 15%, a 1 second load pulse is applied every 3 seconds until the Slide Valve position is \geq 15%.
- b. **Motor FLA** – This method limits the Slide Valve minimum position to one that will maintain the compressor motor current above the programmed **Minimum Load FLA** (15% to 70% FLA) Setpoint after the chiller has been running for 3 minutes. When the Slide Valve unloads to the point where the motor current decreases to the Minimum Load FLA Setpoint, no more unload pulses will be applied. If it unloads to the point where the motor current is < Minimum Load FLA Setpoint, a 1 second load pulse is applied every 3 seconds until the motor current is \geq the Minimum Load FLA Setpoint.

Service Technicians refer to YORK Service Manual 160.80-M1.

Minimum Load FLA

Access Level Required: SERVICE

Only displayed if Motor FLA is selected as the Minimum Load Control Source. Allows the user to set the motor current value to that which will maintain the Slide Valve position above the minimum allowed position. Service Technicians refer to YORK Service manual 160.80-M1.

NAVIGATION**Home**

Access Level Required: VIEW

Causes an instant return to the Home Screen.

Hot Gas

Access Level Required: SERVICE

Only available if the system uses Hot Gas Bypass. Moves to the sub-screen allowing for the setup of Hot Gas. Service Technicians refer to YORK Service Manual 160.80-M1.

Slide Valve Calibration

Access Level Required: SERVICE

Only available if the chiller is stopped. Moves to the sub-screen allowing calibration of the Slide Valve. Service Technicians refer to YORK Service Manual 160.80-M1.

HOT GAS BYPASS SCREEN



FIG. 10 - HOT GAS BYPASS SCREEN

00224VIP

The HOT GAS BYPASS Screen, accessed from the COMPRESSOR Screen, displays a pictorial of the bypass line and solenoid valve location on the chiller. The Hot Gas ON and OFF Setpoints are programmed on this screen and system parameters pertinent to Hot Gas Bypass operation are displayed. An LED illuminates when the Hot Gas Solenoid is ON. If the chiller is equipped with the Hot Gas Bypass option, operation must be enabled on the OPERATIONS Screen.

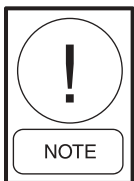

Requires a login access level of SERVICE. Service Technicians refer to YORK Service Manual 160.80-M1 for operation instructions and explanation of all programmable setpoints and displayed values.

DISPLAY ONLY

Slide Valve Position

The value displayed represents the position of the slide valve relative to fully closed at 0% and fully open at 100%.

Return Chilled Liquid Temperature

Displays the temperature of the liquid as it enters the evaporator.

Leaving Chilled Liquid Temperature

Displays the temperature of the liquid as it leaves the evaporator.

Hot Gas Solenoid (LED)

Indicates whether the solenoid is presently energized.

PROGRAMMABLE

On Setpoint

The Hot Gas Bypass solenoid valve is turned on when the Return Chilled Liquid Temperature decreases to \leq the number of degrees of this On Setpoint above the Leaving Chilled Liquid Temperature Setpoint. The ON Setpoint is programmed over the range of 1.0 to 10.0° F (default 1.0). Service Technicians refer to YORK Service Manual 160.80-M1 for an explanation of this setpoint.

Off Setpoint

Once the Hot Gas Bypass solenoid valve is turned on, it is turned off when the Return Chilled Liquid Temperature increases above the Leaving Chilled Liquid Temperature Setpoint by greater than or equal to the number of degrees of this Off Setpoint. The OFF setpoint is programmed over the range of 2.0 to 15.0° F (default 2.0). Service Technicians refer to YORK Service Manual 160.80-M1 for an explanation of this setpoint.

NAVIGATION

Home

Access Level Required: VIEW

Causes an instant return to the Home Screen.

Compressor

Access Level Required: VIEW

Return to the Compressor Screen.

SLIDE VALVE CALIBRATION SCREEN

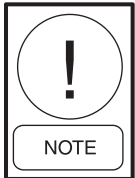

FIG. 11 - SLIDE VALVE CALIBRATION SCREEN

00225VIP

OVERVIEW

This screen displays a cutaway view of the chiller compressor, revealing the rotary screw and slide valve and provides the capability of calibrating the slide valve.



Requires a login access level of SERVICE. Service Technicians refer to YORK Service Manual 160.80-M1 for operation instructions and explanation of all programmable setpoints and displayed values.

DISPLAY ONLY

Slide Valve Loading (LED)

Indicates the slide valve is loading.

Slide Valve Unloading (LED)

Indicates the slide valve is unloading.

Calibration Messages

These are text messages which step the user through the calibration process and indicate its success or failure.

PROGRAMMABLE

Start Calibration

This option is hidden after calibration has started. Service Technicians refer to YORK Service Manual 160.80-M1 for an explanation of this setpoint.

Cancel Calibration

This option only becomes available after calibration has started. Service Technicians refer to YORK Service Manual 160.80-M1 for an explanation of this setpoint.

NAVIGATION

Home

Access Level Required: VIEW

Causes an instant return to the Home Screen.

Compressor

Access Level Required: VIEW

Return to the Compressor Screen.

This page intentionally left blank

OIL SEPARATOR SCREEN

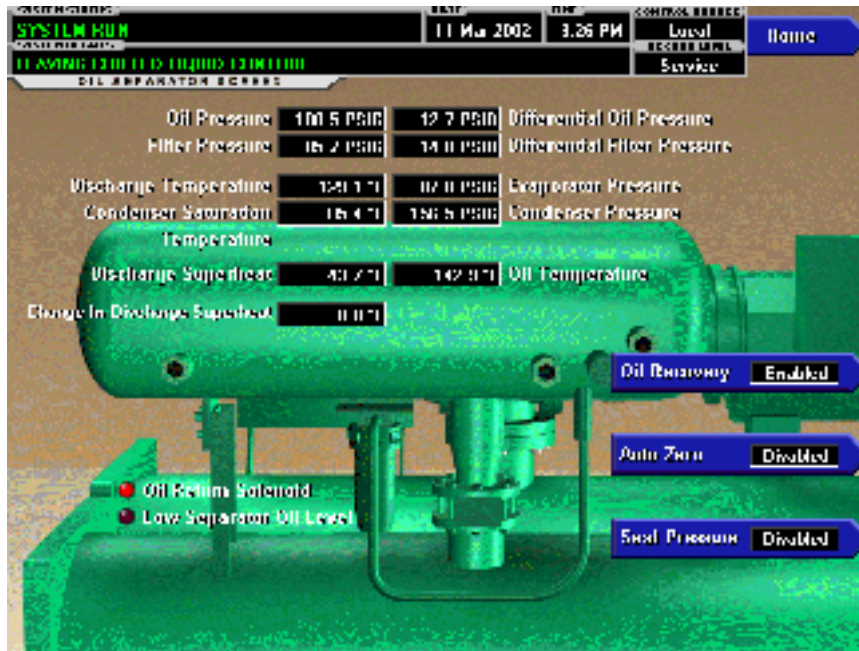

FIG. 12 - OIL SEPARATOR SCREEN

00645VIP

OVERVIEW

This screen displays a close-up of the chiller oil sump and provides all the necessary setpoints for maintaining the oil.

DISPLAY ONLY**Discharge Temperature**

Displays the temperature of the refrigerant in its gaseous state at discharge of the compressor as it travels to the condenser.

Oil Temperature

Displays the temperature of the oil in the sump.

Discharge Superheat

Displays the temperature differential between the Discharge Temperature and the Condenser Saturation Temperature.

Change in Discharge Superheat

(Flash Memory Card version C.MLM.03.03.xxx & later)

Only displayed if the Oil Recovery feature is enabled. Displays the change in Discharge Superheat that occurs in rolling 5 second intervals. Value displayed is the present superheat minus the superheat 5 seconds ago. Increases are displayed as xx.x. Decreases are displayed as -xx.x.

Oil Pressure

Displays the pressure of the oil at the input to the compressor.

Filter Pressure

Displays the pressure of the oil at the input to the filter.

Seal Pressure

Displays the pressure of the oil at the seal.

Differential Oil Pressure

Displays the pressure differential between the oil pressure (as sensed at the input to the compressor) and the evaporator pressure. If either of the transducers used to calculate this differential is out of range, the display field will show XX.X. The displayed value includes the offset pressure that is derived during the first 15 seconds of "Start Sequence Initiated" (Refer to the following explanation of offset pressure).

$$\text{Differential Oil Pressure} = \\ (\text{Seal Oil Pressure} - \text{Evaporator Pressure}) \\ + \text{Offset Pressure}$$

Differential Filter Pressure

Displays the pressure differential between the input to the oil filter and the input to the compressor. This value

is used to check for filter clogging. If either of the transducers used to calculate this differential is out of range, the display field will show XX.X. The displayed value includes the offset pressure that is derived during the first 15 seconds of “Start Sequence Initiated”. (Refer to the following explanation of offset pressure).

$$\text{Differential Filter Pressure} = (\text{Filter Pressure} - \text{Oil Pressure}) \pm \text{Offset Pressure}$$

Differential Seal Pressure

Displays the pressure differential between the seal oil pressure and the evaporator pressure. This value is used to check for a seal going bad. If either of the transducers used to calculate this differential is out of range, the display field will show XX.X. The displayed value includes the offset pressure that is derived during the first 15 seconds of “Start Sequence Initiated” (Refer to the following explanation of offset pressure).

$$\text{Differential Seal Pressure} = (\text{Seal Oil Pressure} - \text{Evaporator Pressure}) \pm \text{Offset Pressure}$$

Offset Pressure

The Offset Pressure is a calculated value that is used to calculate the differential pressure. The Offset Pressure is the pressure differential between the corresponding transducers during the first 15 seconds of START SEQUENCE INITIATED. This is the transducer auto-zeroing. During this time the transducers will be sensing the same pressure and their outputs should be equal. However, due to accuracy tolerances in transducer design, differences can exist. Therefore, to compensate for differences between transducers and assure differential pressure sensing accuracy, the Offset Pressure is subtracted from the differential pressure. (Certain operating conditions could require the auto-zeroing to be disabled. This must never be done by anyone other than a qualified service technician.

Oil Return Solenoid (LED)

Indicates whether the solenoid is energized.

Low Separator Oil Level (LED)

The oil level indicator in the separator is detecting a low oil level.

PROGRAMMABLE

Auto Zero (Enabled / Disabled)

Access Level Required: SERVICE

Allows the user to enable or disable the transducer auto-zeroing that is used to calculate the offset pressure. (Refer to the description of the Offset Pressure). Service Technicians refer to YORK Service Manual 160.80-M1.

Seal Pressure (Enabled / Disabled)

Access Level Required: SERVICE

Allows the user to enable or disable the use of the seal oil pressure transducer. Service Technicians refer to YORK Service Manual 160.80-M1.

Oil Recovery (Enabled/Disabled)

(Flash Memory Card version C.MLM.03.03.xxx & later)

Access Level Required: OPERATOR

Allows the user to enable or disable the Oil Recovery feature. It should be enabled or disabled only under the recommendation and guidance of a qualified Service technician. Since this feature limits slide valve loading under certain conditions, chiller capacity will be limited while the conditions are in effect. Therefore, this feature should not be enabled unless oil recovery is necessary. Refer to feature description in Section 1.

NAVIGATION

Home

Access Level Required: VIEW

Causes an instant return to the Home Screen.

ELECTRO-MECHANICAL STARTER SCREEN



FIG. 13 - ELECTRO-MECHANICAL STARTER SCREEN

00227VIP

OVERVIEW

This screen displays all information pertaining to an Electro-Mechanical Starter.

DISPLAY ONLY

Motor Run (LED)

Indicates whether the digital output from the controls is commanding the motor to **RUN**.

Motor Current % Full Load Amps

Displays the motor current as a percentage of the Full Load Amps (FLA) value. For the Electro-Mechanical Starter this is the data returned by the CM-2 board.

Current Limit Setpoint

Displays the current limit value in use. This value could come from a 0-20mA, 4-20mA, 0-10VDC or 2-10VDC input in Analog Remote mode, PWM signal in Digital Remote mode, Microgateway interface in ISN mode, or a locally programmed value.

Pulldown Demand Time Left

Displays the time remaining in the programmed pulldown period if the value is nonzero.

PROGRAMMABLE

Local Motor Current Limit

Access Level Required: OPERATOR

Allows the user to specify the maximum allowed motor current (as a percentage of FLA). When the motor current reaches this value, the slide valve will not be permitted to load further. If the motor current rises above this value, the slide valve will unload to reduce the current to this value.

Pulldown Demand Limit

Access Level Required: OPERATOR

Allows the user to specify the current limit value (as a percentage of FLA) to which the chiller will be limited during the specified pulldown limit time. This value will override the Motor Current Limit value during this time period. This function is used to provide energy savings following chiller start-up.

Pulldown Demand Time

Access Level Required: OPERATOR

Allows the user to set a period of time for which the pulldown demand limit will be in effect after the chiller starts.

NAVIGATION

Home

Access Level Required: VIEW

Causes an instant return to the Home Screen.

MOD "A" SOLID STATE STARTER SCREEN



FIG. 14 - MOD "A" SOLID STATE STARTER SCREEN

00228VIP

OVERVIEW

This screen displays all information pertaining to the Mod "A" Solid State Starter.

DISPLAY ONLY

Motor Run (LED)

Indicates whether the digital output from the controls is commanding the motor to RUN.

Motor Current % Full Load Amps

Displays the motor current as a percentage of the Full Load Amps (FLA) value. For this Solid State Starter this is the data returned by the Starter Logic board.

Current Limit Setpoint

Displays the current limit value in use. This value could come from a 0-20mA, 4-20 mA, 0-10VDC, or 2-10VDC input in Analog Remote mode, PWM signal in Digital Remote mode, Microgateway interface in ISN mode, or a locally programmed value in local mode.

Pulldown Demand Time Left

Displays the time remaining in the programmed pulldown period.

Scale/Model

Display information about the Liquid Cooled-Solid State Starter (LC-SSS) Rating and the maximum allowed Full Load Amps.

Voltage - Phase A, B, C

Display the 3-phase input line voltage values being read from the Solid State Starter.

Current - Phase A, B, C

Display the 3-phase motor current values being read from the Solid State Starter.

PROGRAMMABLE

Local Motor Current Limit

Access Level Required: OPERATOR

Allows the user to specify the maximum allowed motor current (as a percentage of FLA). When the motor current reaches this value, the slide valve will not be permitted to load further. If the motor current rises above this value, the slide valve will unload to reduce the current to this value.

Pulldown Demand Limit

Access Level Required: OPERATOR

Allows the user to specify the current limit value (as a percentage of FLA) to which the chiller will be limited during the specified pulldown limit time. This value will override the Motor Current Limit value during this time period. This function is used to provide energy savings following chiller startup.

Pulldown Demand Time

Access Level Required: OPERATOR

Allows the user to set a period of time for which the pulldown demand limit will be in effect after the chiller starts.

Full Load Amps

Access Level Required: SERVICE

Defines the maximum amps at which the motor can operate. This value is viewable when logged in under the Operator or View access level. Service Technicians refer to YORK Service Manual 160.80-M1.

Supply Voltage Range

Access Level Required: SERVICE

Allows the user to select a specific voltage range for voltage checking. When not disabled, this line voltage range is used to determine a low line and high line voltage threshold for initiating a shutdown. Service Technicians refer to YORK Service Manual 160.80-M1.

Current Unbalance Check (Enabled / Disabled)

Access Level Required: SERVICE

Allows the user to control whether the logic checks for current unbalance and initiates a shutdown as a result. Service Technicians refer to YORK Service Manual 160.80-M1.

NAVIGATION**Home**

Access Level Required: VIEW

Causes an instant return to the Home Screen.

MOD "B" SOLID STATE STARTER SCREEN



FIG. 15 - MOD "B" SOLID STATE STARTER SCREEN

00342VIP

OVERVIEW

This screen displays information pertaining to the Mod "B" Solid State Starter.

DISPLAY ONLY

Motor Run (LED)

Indicates whether the digital output from the controls is commanding the motor to RUN.

Motor Current % Full Load Amps

Displays the motor current as a percentage of the Full Load Amps (FLA) value.

Current Limit Setpoint

Displays the current limit value in use. This value could come from a 0-20mA, 4-20 mA, 0-10VDC or 2-10VDC input in Analog Remote mode, PWM signal in Digital Remote mode, Microgateway interface in ISN remote mode, or a locally programmed value in local mode.

Pulldown Demand Time Left

Displays the time remaining in the programmed pulldown period.

Input Power

Displays the Kilowatts measured by the Solid State Starter.

KW Hours

Displays the cumulative amount of kilowatts used over time.

Starter Model

Displays the Solid State Starter model that is applied to the chiller. Starter Models are 7L, 14L, 26L, or 33L.

Voltage - Phase A, B, C

Display the 3-phase input line voltage measured by the Solid State Starter.

Current - Phase A, B, C

Display the 3-phase motor current values measured by the Solid State Starter.

Temperature - Phase A, B, C

Displays the temperatures of the Silicon Controlled Rectifier assemblies.

PROGRAMMABLE

Local Motor Current Limit

Access Level Required: OPERATOR

Allows the user to specify the maximum allowed motor current (as a percentage of FLA). When the motor current reaches this value, the slide valve will not be permitted to load further. If the motor current rises above this value, the slide valve will unload to reduce the current to this value.

Pulldown Demand Limit

Access Level Required: OPERATOR

Allows the user to specify the current limit value (as a percentage of FLA) to which the chiller will be limited during the specified pulldown limit time. This value will override the Motor Current Limit value during this time period. This function is used to provide energy savings following chiller start-up.

Pulldown Demand Time

Access Level Required: OPERATOR

Allows the user to set a period of time for which the pulldown demand limit will be in effect after the chiller starts.

Full Load Amps

Access Level Required: SERVICE

Defines the maximum amps at which the motor can operate. This value is viewable when logged in under the Operator or View access level. Service Technicians refer to YORK Service Manual 160.80-M1.

Voltage Range

Access Level Required: SERVICE

Allows the user to select specific line voltage range for voltage checking. When not disabled, this line voltage range is used to determine a low line and high line voltage threshold for initiating a shutdown. Service Technicians refer to YORK Service Manual 160.80-M1.

Starting Current

Access Level Required: SERVICE

Defines the maximum allowed motor starting amps. The Solid State Starter will limit the motor starting current to this value. Service Technicians refer to YORK Service Manual 160.80-M1.

Open SCR (Enabled/Disabled)

Access Level Required: SERVICE

Allows the user to enable or disable the Solid State Starter Open SCR safety detection. This must never be disabled unless under advisement of the YORK Factory. Service Technicians refer to YORK Service Manual 160.80-M1.

Shorted SCR (Enabled/Disabled)

(Flash Memory Card version C.MLM.03.01 or later)

Access Level Required: SERVICE

Allows the user to enable or disable the Solid State Starter Shorted SCR safety detection. This must never be disabled unless under advisement of the YORK Factory. Service Technicians refer to YORK Service Manual 160.80-O1.

KWH Reset

Access Level Required: SERVICE

Allows the user to reset the cumulative Kilowatt Hours. Service Technicians refer to YORK Service Manual 160.80-M1.

NAVIGATION**Home**

Access Level Required: VIEW

Causes an instant return to the Home Screen.

SETPOINTS SCREEN



FIG. 16 - SETPOINTS SCREEN

00230VIP

OVERVIEW

This screen provides a convenient location for programming the most common setpoints involved in the chiller control. This screen also serves as a gateway to a sub-screen for defining the setup of general system parameters.

DISPLAY ONLY

Leaving Chilled Liquid Temperature - Setpoint

Displays the present setpoint to which the chiller is operating whether controlled remotely or locally. This value could come from a 0-20mA, 4-20 mA, 0-10VDC or 2-10VDC input in Analog Remote mode, PWM signal in Digital Remote mode, Microgateway interface in ISN remote mode, or a locally programmed value in local mode.

Leaving Chilled Liquid Temperature Cycling - Shutdown

Displays the Leaving Chilled Liquid Temperature at which the chiller will shut down to avoid over-cooling the building. This value is calculated by subtracting the Leaving Chilled Liquid Temperature Cycling Offset – Shutdown from the Leaving Chilled Liquid Temperature – Setpoint. If this value is below the absolute minimum allowed shutdown temperature the minimum value is displayed.

Leaving Chilled Liquid Temperature Cycling – Restart

Displays the Leaving Chilled Liquid Temperature at which the chiller will restart after it has shut down due to over-cooling temperature. This value is calculated by adding the Leaving Chilled Liquid Temperature Cycling Offset – Restart to the Leaving Chilled Liquid Temperature – Setpoint.

Current Limit Setpoint

Displays the present setpoint to which the chiller is operating whether controlled remotely or locally. This value could come from a 0-20mA, 4-20mA, 0-10VDC or 2-10VDC input in Analog Remote mode, PWM signal in Digital Remote mode, Microgateway interface in ISN remote mode, or a locally programmed value in Local mode.

PROGRAMMABLE

Local Leaving Chilled Liquid Temperature - Range *Access Level Required: OPERATOR*

This is the range over which an analog signal (0-20mA, 4-20mA, 0-10VDC or 2-10VDC) in Analog Remote Mode or a digital signal (PWM) in Digital Remote mode can reset the Leaving Chilled Liquid Temperature setpoint above the operator programmed **Base** Setpoint (see below). Programmable as either 10, 20, 30 or 40°F, with a default of 10°F, it is added to the *BASE* value to create a range over which the remote device can reset the

setpoint. For example, if this setpoint is programmed for 10°F and the operator programmed value is 45°F, then the remote device can set the Leaving Chilled Liquid Temperature setpoint over the range 45.0° - 55.0°F.

Local Leaving Chilled Liquid Temperature - Setpoint

Access Level Required: OPERATOR

This value allows the user to define the Leaving Chilled Liquid Temperature that is to be maintained by the chiller. It is programmable over the range of 38.0°F to 70.0°F (water) or 20.0°F to 70.0°F (brine). If Smart Freeze is enabled, the range is 36.0°F to 70.0°F (water). A remote device can provide an analog signal (0-20mA, 4-20mA, 0-10VDC, or 2-10VDC) in Analog Remote mode, or PWM signal in Digital Remote mode that changes the setpoint by creating an offset above the operator programmed *BASE* Leaving Chilled Liquid Temperature setpoint. This offset may be defined up to 10.0°F, 20.0°F, 30.0°F, or 40.0°F above the *BASE* setpoint (see the Remote Leaving Chilled Liquid Temperature Setpoint Range description above). Additionally, a Microgateway (in ISN Remote mode) can define the setpoint through a serial data stream. In this case, the incoming setpoint is not an offset that is applied to the locally programmed *BASE* setpoint value, but rather is the setpoint value itself.

Leaving Chilled Liquid Temperature Cycling Offset - Shutdown

Access Level Required: OPERATOR

This value allows the user to specify the Leaving Chilled Liquid Temperature at which the chiller will shut down on a **LEAVING CHILLED LIQUID – LOW TEMPERATURE** cycling shutdown. This is done by defining an offset below the Leaving Chilled Liquid Temperature setpoint. It is programmable over a range of 1°F to 64°F below the setpoint, to a minimum cutout of 36°F (water), 34°F (water with Smart Freeze enabled) or 16°F (brine). It establishes the minimum allowed temperature for the Leaving Chilled Liquid Temperature and prevents over-cooling of the building. Anytime the Leaving Chilled Liquid Temperature setpoint is increased, the shutdown threshold is 36.0°F (water) or 16.0°F (brine) for the next ten (10) minutes. If Smart Freeze is enabled, the threshold is 34.0°F for the next 10 minutes. After ten (10) minutes have elapsed, the shutdown threshold becomes the programmed setpoint value.

Leaving Chilled Liquid Temperature Cycling Offset - Restart

Access Level Required: OPERATOR

This value allows the user to specify the Leaving Chilled Liquid Temperature at which the chiller will restart after

a shutdown on a **LEAVING CHILLED LIQUID – LOW TEMPERATURE** cycling shutdown. This is done by defining an offset above the Leaving Chilled Liquid Temperature setpoint. It is programmable over a range of 0°F to 70°F above the setpoint, to a maximum restart value of 80°F. The chiller will automatically restart when this temperature is reached. This setpoint can be used to reduce chiller cycling by delaying the chiller restart until the cooling load has increased.

Remote Analog Input Range

Access Level Required: OPERATOR

This setpoint defines, for the Control Center, the remote signal range applied for remote reset of the Leaving Chilled Liquid Temperature Setpoint and Current Limit Setpoint in ANALOG remote mode. If the remote signal is 0-10VDC or 0-20mA, this setpoint must be programmed for 0-10VDC. If the remote signal is 2-10VDC or 4-20mA, this setpoint must be programmed for 2-10VDC.

Local Motor Current Limit

Access Level Required: OPERATOR

Allows the user to specify the maximum allowed motor current (as a percentage of FLA). When the motor current reaches this value, the slide valve will not be permitted to load further. If the motor current rises above this value, the slide valve will unload to reduce the current to this value.

Pulldown Demand Limit

Access Level Required: OPERATOR

Allows the user to specify the current limit value (as a percentage of Full Load Amps) to which the chiller will be limited during the specified pulldown limit time. This value will override the Motor Current Limit value during this time period. This function is used to provide energy savings following chiller startup.

Pulldown Demand Time

Access Level Required: OPERATOR

Allows the user to set a period of time for which the pulldown demand limit will be in effect after the chiller starts.

Print

Access Level Required: VIEW

Generates **Setpoints** print report.

NAVIGATION

Home

Access Level Required: VIEW

Causes an instant return to the Home Screen.

Setup

Access Level Required: VIEW

Moves to the sub-screen allowing setup of general system parameters.

SETUP SCREEN



FIG. 17 - SETUP SCREEN

LD09573

OVERVIEW

This screen is the top level of the general configuration parameters. It allows programming of the time and date, along with specifications as to how the time will be displayed (12 or 24 hour format). In addition, the chiller configuration, as determined by the state of the Micro Board Program Jumpers and Program Switches is displayed. A qualified Service Technician, following instructions in YORK Service Manual 160.80-M1, establishes this configuration per the desired operation. This screen also serves as a gateway to more sub-screens for defining general system parameters.

DISPLAY ONLY

031-01730-000 MICROBOARD

Chilled Liquid Pump Operation:
Displays **Standard** or **Enhanced**

Refrigerant Selection:
Displays **R-22** or **R134a**

Anti-Recycle:
Displays **Disabled** or **Enabled**

Power Failure Restart:
Displays **Manual** or **Automatic**

Liquid Type:
Displays **Water** or **Brine**

031-02430-000 MICROBOARD

Refrigerant Selection
Displays R134a or R22

Liquid Type
Displays Water or Brine

PROGRAMMABLE

Set Date

Access Level Required: OPERATOR

Allows the user to specify the present date. This value is critical to logging system shutdowns accurately and for utilizing the scheduling capabilities. When prompted to enter a date value, the user must enter the day, month, and four-digit year (using leading zeroes as necessary). If within range, the value will be accepted. If out of range, the user is prompted for the information again. At this point the user may retry the date entry, or cancel the programming attempt.

Set Time

Access Level Required: OPERATOR

Allows the user to specify the present time. This value is critical to logging system shutdowns accurately and for utilizing the scheduling capabilities. When prompted to enter a time value, the user must enter the hour and

minute desired (using leading zeroes as necessary). If the chiller is presently set to 24-hour mode, the time must be entered in the 24-hour format. Otherwise, the user must also select AM or PM for the entered time. If out of range, the user is prompted for the information again. At this point the user may retry the time entry, or cancel the programming attempt.

Clock (Enabled / Disabled)

Access Level Required: OPERATOR

Allows the user to enable or disable the real-time clock in order to conserve battery life. The clock will be disabled during manufacturing and must be enabled at system commissioning. In addition, when preparing for prolonged shutdown the clock should once again be disabled.

12/24 Hr

Access Level Required: OPERATOR

Allows the user to specify the format in which the time will be presented to the user. This setpoint will affect the display of the time on the chiller panel and on all reports generated. 12-Hour time format will include the **AM** and **PM** modifiers and show the range of time between 1:00 and 12:59, while the 24-Hour time format will show the range of time between 0:00 and 23:59.

031-02430-000 MICROBOARD ONLY

Change Settings

Access Level Required: OPERATOR or higher

Used to enter the following setpoints. Pressing this key places a green selection box around the first changeable setpoint. The access level determines which setpoints can be changed. Use the ▲ and ▼ keys to place the selection box around the desired setpoint. With the setpoint selected, press the ENTER (✓) key. A dialog box appears with the range of settings.

Chilled Liquid Pump Operation

Access Level Required: SERVICE Allows a Service Technician to select chilled liquid pump control contacts (I/O Board TB2-44/45) operation as either Standard or Enhanced. Service Technicians refer to YORK Service Manual 160.80-M1.

Motor Drive Type

Access Level Required: SERVICE

Allows a Service Technician to enter the applied compressor motor type as either electro- mechanical (EM), Solid State Starter (SSS-Mod A) or Solid State starter (SSS – Mod B). Service Technicians refer to YORK Service manual 160.80-M1.

Anti-Recycle

Access level Required: SERVICE

Allows a Service Technician to Enable or Disable the anti-recycle timer. Service Technicians refer to YORK Service manual 160.80-M1.

Power Failure Restart

Access Level Required: OPERATOR

Allows the user to select Manual or Automatic restart after power failure.

NAVIGATION

Home

Access Level Required: VIEW

Causes an instant return to the Home Screen.

Schedule

Access Level Required: VIEW

Moves to the sub-screen allowing definition of the chiller operation schedule.

Diagnostics

Access Level Required: SERVICE

Moves to the sub-screen allowing limited diagnostic capability while operating. Refer to YORK Service Manual 160.80-M1.

Comms

Access Level Required: VIEW

Moves to the sub-screen allowing configuration of system communications.

Printer

Access Level Required: VIEW

Moves to the sub-screen allowing configuration and control of printer functions.

Sales Order

Access Level Required: VIEW

Moves to the sub-screen displaying the Sales Order information for the chiller system.

Operations

Access Level Required: VIEW

Moves to the sub-screen displaying operating parameters of the chiller system.

User

Access Level Required: VIEW

Moves to the sub-screen allowing configuration of user preferences.

SCHEDULE SCREEN



FIG. 18 - SCHEDULE SCREEN

00232VIP

OVERVIEW

The schedule screen contains more programmable values than a normal display screen. As such, each programmable value is not linked to a specific button. Instead the **Select** key is used to enable the cursor arrows which are used to highlight the day and the start or stop time the user wishes to modify. At this point the user may press the 'T' (**Check**) key to program the Start / Stop times for that day.

In order for the Start / Stop combination to be utilized, each Start time must have a corresponding Stop time which occurs later in the day. The presently programmed schedule for a given day can be cancelled by setting both the Start and Stop time to 12:00AM. If the Start time equals the Stop time (with any time other than 12:00AM), the chiller is OFF for that day. If the user desires the chiller to operate continuously through several days, the Stop time of Day 1 can be set to 11:59 PM and the Start time of Day 2 can be set to 12:00 AM. The chiller will not stop but continue to operate until the stop of Day 2.

The user has the ability to define a standard set of Start / Stop times which are utilized every week. The user may then specify *exception* Start / Stop combinations for any day of the week up to 6 weeks in advance. At the end of each week the schedule for the next week is created by combining the standard week definition and the next defined exception week. The schedule is then updated

as each of the exception weeks “shifts down”, leaving a new, blank exception week in the 6th week slot.

DISPLAY ONLY

None

PROGRAMMABLE

Standard Week Start/Stop Times

Access Level Required: OPERATOR

For each day of the week, the user may specify a time for the chiller to start and a time for the chiller to stop. The times specified in this entry week will be used as the default for every week of chiller operation.

Exception Start/Stop Times

Access Level Required: OPERATOR

For each day of the week, the user may specify a time for the chiller to start and a time for the chiller to stop. These Start / Stop combinations may be scheduled up to five (5) weeks in advance and also for the present week. As each week goes by, the new schedule will be created for the present week using the Exception specification in combination with the Standard week definition, as described above.

Schedule (Enabled / Disabled)

Access Level Required: OPERATOR

Allows the user to enable or disable the monitoring function which enforces the scheduled starting and stopping of the chiller.

Repeat Sunday Schedule

Access Level Required: OPERATOR

Duplicates the schedule defined for Sunday for the remainder of the standard weekdays.

Reset All Exception Days

Access Level Required: OPERATOR

Deletes all programming for exception days within the next 6 weeks.

Select

Access Level Required: OPERATOR

Places a selection box around a start time for a given day. Use ◀, ▶, ▲ or ▼ cursor arrows to place the box around the desired start or stop time for a given day.

Print

Access Level Required: VIEW

Generates a **Schedule** print report.

NAVIGATION**Home**

Access Level Required: VIEW

Causes an instant return to the Home Screen.

Setup

Access Level Required: VIEW

Return to the previous setup screen.

USER SCREEN



FIG. 19 - USER SCREEN

00343VIP

OVERVIEW

This screen allows definition of custom User ID's and matching passwords. This allows the building administrator to assign custom passwords to those who are authorized to maintain the chiller.

Each Custom User value is not linked to a specific button. Instead, the **Change** button is pressed which enables the cursor arrows which are used to highlight the Custom User parameter the user wishes to modify. At this point the '✓' (**Check**) button is pressed and the value may be entered.

DISPLAY ONLY

None

PROGRAMMABLE

System Language

Access Level Required: OPERATOR

Allows the user to define the language for all Screens. The desired language is selected by scrolling through the list of those available. English is the Default language and is selected by pressing the s key when the dialog box appears during the selection process. The selected language will not be displayed until after the user navigates from the USER Screen to another Screen.

English / Metric Units

Access Level Required: OPERATOR

Define the unit system (English or Metric) used by the chiller display.

Custom User ID (4)

Access Level Required: SERVICE

This allows the user to specify up to four (4) Custom User ID values. Each user ID will then require a corresponding Password and User Level. A User ID can be defined for various maintenance personnel. Service Technicians refer to YORK Service Manual 160.80-M1.

Custom User Password (4)

Access Level Required: SERVICE

This allows the user to specify up to four (4) Custom Password values. Each Password will then require a corresponding User ID and User Level. Service Technicians refer to YORK Service Manual 160.80-M1.

Custom User Access Level (4)

Access Level Required: SERVICE

This allows the user to specify up to four (4) Custom User Access Levels. Each Access Level will then require a corresponding Password and User ID. Service Technicians refer to YORK Service Manual 160.80-M1.

NAVIGATION

Home

Access Level Required: VIEW

Causes an instant return to the Home Screen.

Setup

Access Level Required: VIEW

Return to the Setup Screen.

COMMS SCREEN



FIG. 20 - COMMS SCREEN

00447VIP

OVERVIEW

(Screen shown from Flash Memory Card version C.MLM.03.02.xxx and later. Screen layout from earlier versions slightly different). This screen allows definition of the necessary communications parameters. Refer to PRINTER Section of this book for details of the Printer connections and setup. Presently, there are no COM 2 communications features available.

DISPLAY ONLY

None

PROGRAMMABLE

Chiller ID

Access Level Required: OPERATOR

Define the numeric chiller ID when used within an ISN network of chillers. This ID number is also printed at the top of reports obtained with a local printer.

Printer Setup and COM 2 Setup

Access Level Required: OPERATOR

Pressing either key places a green selection box around the first changeable parameter. Use the ▲ and ▼ keys to place the selection box around the desired parameter to be changed. With the selection box around the desired parameter, press the ENTER (✓) key. A dialog box is displayed permitting data entry.

Printer Baud Rate

Define the baud rate at which the panel shall communicate to the printer.

Printer Data Bit(s)

Define the number of data bits with which the panel shall communicate to the printer.

Printer Parity Bit(s)

Define the number of parity bits with which the panel shall communicate to the printer.

Printer Stop Bit(s)

Define the number of stop bits with which the panel shall communicate to the printer.

COM 2 Baud Rate

Define the baud rate at which the panel shall communicate through the modem port.

COM 2 Data Bit(s)

Define the number of data bits with which the panel shall communicate to the modem port.

COM 2 Parity Bit(s)

Define the number of parity bits with which the panel shall communicate through the modem port.

COM 2 Stop Bit(s)

Define the number of stop bits with which the panel shall communicate through the modem port.

NAVIGATION

Home

Access Level Required: VIEW

Causes an instant return to the Home Screen.

Setup

Access Level Required: VIEW

Return to the Setup Screen.

PRINTER SCREEN

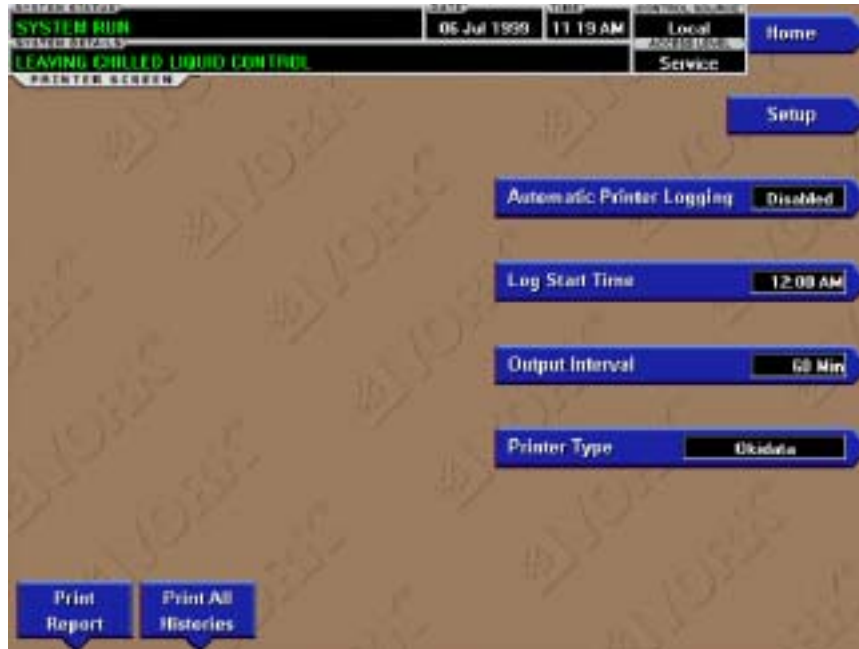

FIG. 21 - PRINTER SCREEN

00235VIP

OVERVIEW

This screen allows definition of the necessary communications parameters for the printer. Refer to PRINTER section of this book for details of the Printer connections and setup.

DISPLAY ONLY

Time Remaining Until Next Print

Displays the time until the next print log will occur, if the function is enabled.

PROGRAMMABLE

Log Start Time

Access Level Required: OPERATOR

Set the time at which scheduled print logs will begin.

Output Interval

Access Level Required: OPERATOR

Define the interval at which log printing will occur.

Automatic Printer Logging (Enabled / Disabled)

Access Level Required: OPERATOR

Enable the printer to begin printing status reports beginning at the programmed start time and recurring at the interval defined above.

Printer Type

Access Level Required: OPERATOR

Define the printer type connected to the chiller system.

Print Report

Access Level Required: OPERATOR

Select the report type to print when the Print Report key is selected. This can vary from Status report (present system parameters), Setpoints report (present value of the system setpoints), Schedule report (present value of the system schedule times), or a Sales Order Data report (information provided on the Sales Order screen). A print report is generated upon completion of selection.

Print All Histories

Access Level Required: OPERATOR

Generate a report of the system data at the time of all stored shutdowns.

NAVIGATION

Home

Access Level Required: VIEW

Causes an instant return to the Home Screen.

Setup

Access Level Required: VIEW

Return to the Setup Screen.

SALES ORDER SCREEN

The screenshot shows the SALES ORDER SCREEN interface. At the top, it displays 'SYSTEM RUN', '06 Jul 1999', '11 21 AM', 'Local', and 'Service'. Below this, there are several sections of input fields:

- Date Information:** Commissioning Date (00 000 0000), Job Name, Job Location, Model Number, York Order Number, Panel Serial Number, Chiller Serial Number.
- Nameplate Information:** Motor Code, Volts, Phases, Frequency (Hz), LRA, Full Load Amps, Inrush Amps.
- Design Load:** Evaporator and Condenser sections with fields for Pressure, Design Working Pressure, Loading Factor, Pressure Drop, Nozzle Arrangement In, Nozzle Arrangement Out, Leaving Temperature, Return Temperature, GPM, and Tubes.
- System Information:** Refrigerant, Tons, Gear Code, Input Type, Drive Percent, VSD/SSS/LH, Kilowatts Input.

Navigation buttons include 'Home', 'Service', 'Setup', 'Set Order Info', and 'Print'.

FIG. 22 - SALES ORDER SCREEN

00236VIP

OVERVIEW

This screen allows definition of the sales order parameters. The Commissioning date is entered by the YORK Service Technician at the time of chiller commissioning. These values should never be changed or entered by anyone other than a qualified Service Technician. Entry instructions are included in the YORK Service Manual 160.80-M1. The remainder of the values are entered at the YORK Factory during the manufacturing of the chiller.

DISPLAY ONLY

Model Number

Factory defined model number of the chiller system.

Panel Serial Number

Factory defined serial number for the micropanel.

Chiller Serial Number

Factory defined serial number for the chiller system.

YORK Order Number

Factory defined order number under which the chiller was sold.

System Information

Factory defined conditions for which the chiller was originally rated and sold.

Condenser and Evaporator Design Load Information

Factory defined description of the condenser and evaporator configuration at time of shipment.

Nameplate Information

Factory defined information about the chiller motor configuration.

PROGRAMMABLE

Commissioning Date

Access Level Required: SERVICE

Define the date at which the chiller was commissioned.

Job Name and Location

Access Level Required: SERVICE

Factory defined job name and location the chiller is destined for.

Print

Access level required: VIEW

Generates a Sales Order print report.

NAVIGATION

Home

Access Level Required: VIEW

Causes an instant return to the Home Screen.

Setup

Access Level Required: VIEW

Return to the Setup Screen.

OPERATIONS SCREEN

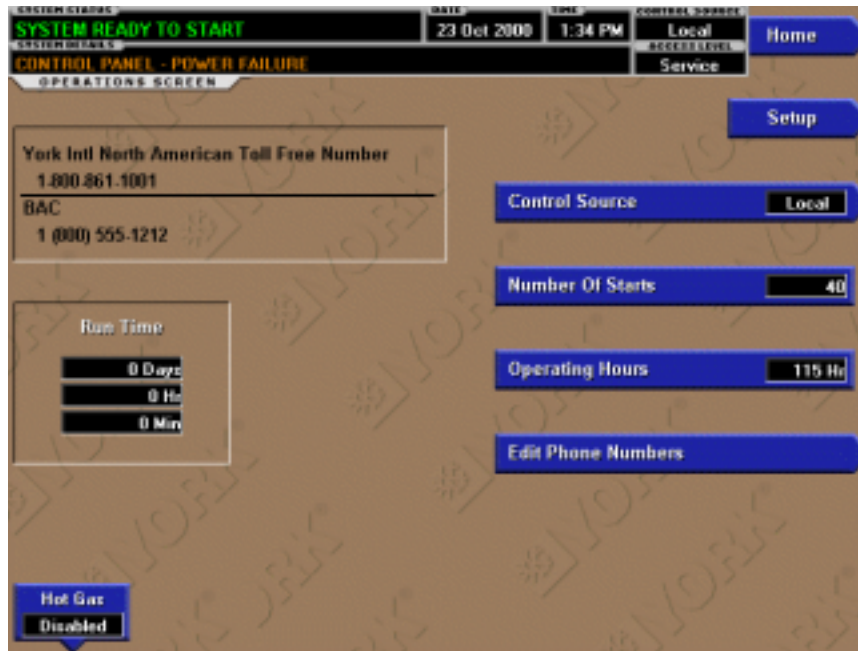

FIG. 23 - OPERATIONS SCREEN

00448VIP

OVERVIEW

This screen allows definition of general parameters having to do with the operation of the chiller.

DISPLAY ONLY

Chiller Run Time

(Flash memory Card version C.MLM.03.01 or later)

Displays the amount of time the chiller has been running since the last start signal was received. Value is reset to zero when the chiller enters Coastdown. It remains at zero while shutdown and during “Start Sequence Initiated.”

PROGRAMMABLE

Control Source

Access Level Required: OPERATOR

Define whether the control of the chiller will be Local, Digital Remote, Analog Remote, Modem Remote or ISN Remote.

Number of Starts

Access Level Required: ADMIN

Displays the number of the starts the chiller has initiated. This may be reprogrammed to a desired value, (generally when this value has been reset due to a Micro Board replacement), but should not be done so arbitrarily.

Operating Hours

Access Level Required: ADMIN

Displays the total accumulated run time of the chiller. This may be reprogrammed to a desired value (generally

when this value has been reset due to a Microboard replacement), but should not be done so arbitrarily.

Service Phone Numbers

(Flash Memory Card version C.MLM.03.02.xxx and later)

Access Level Required: SERVICE

Displays up to two service phone numbers. The Regional service phone number is displayed as the first number. Although the label and number can be changed appropriately, the default for this entry is “York Intl North American Toll Free Number 1-800-861-1001”. The Local service phone number is displayed as the second number. Although blank by default, the appropriate label and number can be entered by a Service Technician. Service Technicians refer to Service Manual 160.80-M1.

Hot Gas Bypass (Enabled / Disabled)

Access Level Required: SERVICE

Enables and Disables the optional Hot Gas Bypass Control Feature.

NAVIGATION

Home

Access Level Required: VIEW

Causes an instant return to the Home Screen.

Setup

Access Level Required: VIEW

Return to the Setup Screen.

This page intentionally left blank

HISTORY SCREEN

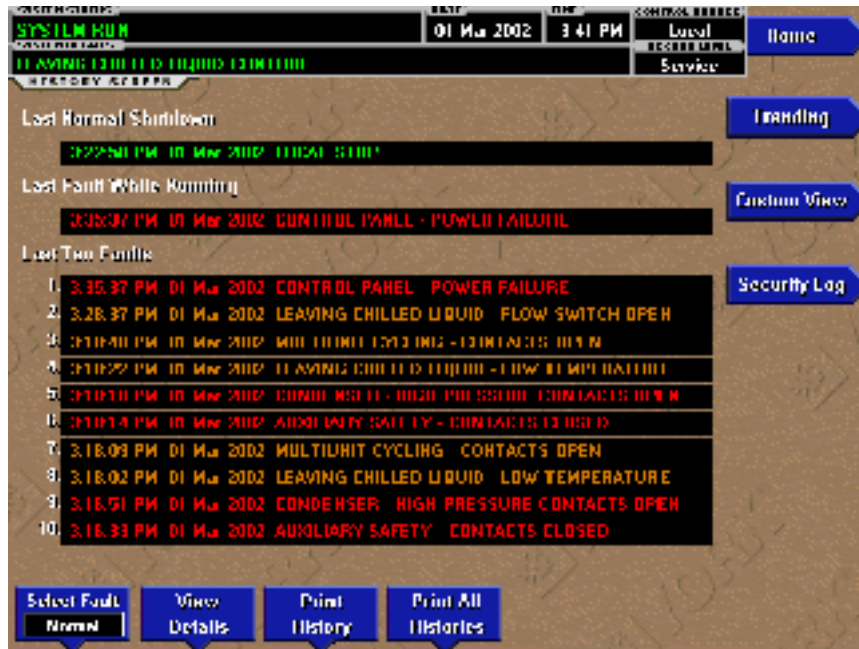

FIG. 24 - HISTORY SCREEN

00646VIP

OVERVIEW

This screen allows the user to browse through the faults. In order to get a more thorough reporting of the system conditions at the time of the recorded shutdown, move to the sub-screen **HISTORY DETAILS**.

The user may use the **Select Fault** button to select the history to view. At this point the **View Details** button is used to jump to a sub-screen containing stored chiller parameters values at the time of the shutdown. Additionally, the **Print History** button can be used to generate a hard-copy report of the parameter values at the time of the shutdown.

DISPLAY ONLY

Last Normal Shutdown

This window displays the date and time and the description of the last normal shutdown. A normal shutdown is defined as:

- Local (Panel rocker switch)
- Remote (Digital, Analog or ISN)

Last Fault While Running

This window displays the date and time and the description of the last safety or cycling shutdown while the system was running.

Last Ten Faults

This window displays a chronological listing (most recent first) of the date and time and the description of the last ten safety or cycling shutdowns that occur while the system is running or stopped.

PROGRAMMABLE

Print History

Access Level Required: VIEW

This generates a report listing the status of the chiller parameters at the time of the selected shutdown.

Print All Histories

Access Level Required: VIEW

This generates a report listing the status of the chiller parameters at the time of each of the stored shutdowns.

NAVIGATION

Home

Access Level Required: VIEW

Causes an instant return to the Home Screen.

View Details

Access Level Required: VIEW

Causes a move to a sub-screen containing the value of select chiller parameters at the time of the associated shutdown.

Trending

Access Level Required: VIEW

Causes a move to a sub-screen allowing the user to view trending data on selected chiller parameters.

Custom View

Access Level required: VIEW

Causes a move to a sub-screen allowing the user to view the Custom Setup Screen.

Security Log

(Flash Memory Card version C.MLM.03.03.xxx & later)

Access Level Required: SERVICE

Causes a move to a sub-screen allowing the user to view a record of the last 75 setpoint changes.

HISTORY DETAILS SCREEN



FIG. 25 - HISTORY DETAILS SCREEN

00647VIP

OVERVIEW

This screen allows the user to see an on-screen printout of all the system parameters at the time of the selected shutdown. Not all screens are shown above. The number of screens required to display all of the data varies according to the type of motor starter and options applied.

DISPLAY ONLY

History Printout

This is the on-screen printout of the system parameters.

PROGRAMMABLE

Page Up

Access Level Required: VIEW

Scroll up in the displayed data (if applicable).

Page Down

Access Level Required: VIEW

Scroll down in the displayed data (if applicable).

Print History

Access Level Required: VIEW

This generates a report listing the status of the chiller parameters at the time of the selected shutdown.

NAVIGATION

Home

Access Level Required: VIEW

Causes an instant return to the Home Screen.

History

Access Level Required: VIEW

Causes a return to the History Screen.

SECURITY LOG

Category	Setpoint	New Value
1 Motor	Submaster Motor Logging	Disabled
2 Motor	Local Motor Current Limit	100%
3 Motor	PullDown Demand Limit	100%
4 Motor	PullDown Demand Time	0 Min
5 System	Remote Analog Input Range	2.10 Volts
6 Evaporator	Refract Offset	5.0 °F
7 Evaporator	Shutdown Offset	5.0 °F
8 Printer	Printer Type	Epson
9 Motor	Output Interval	100 Min
10 Motor	Log Shift Time	10000 Min
11 Motor	Submaster Motor Logging	Enabled
12 Motor	PullDown Demand Time	5 Min
13 Motor	PullDown Demand Time	15 Min
14 Motor	PullDown Demand Limit	50%
15 Motor	Local Motor Current Limit	90%

FIG. 26 - SECURITY LOG

00648VIP

OVERVIEW

(This screen only available with Flash Memory Card version C.MLM.03.03.xxx and later).

This screen displays a listing of the last 75 setpoint changes. They are listed and numbered in reverse order in which they were changed, with the most recent listed as number 1. Multiple pages are necessary to display all 75 changes. Not all setpoints are logged. Service technicians refer to list in YORK Service Manual 160.80-M1.

The details of any setpoint change can be viewed by navigating to a subscreen that displays the date and time of the change, Access Level and USER ID used to make the change, the old setpoint value and the new setpoint value. **Note: Requires a login access level of SERVICE.**

DISPLAY ONLY

Category

Displays the category of the setpoint (motor, evaporator, condenser, etc.)

Setpoint

Displays the setpoint that was changed.

New Value

Displays the value that was entered at the time of the setpoint change.

PROGRAMMABLE

Log Entry

Allows the user to select a particular setpoint change for detail viewing.

Print

Generates a detailed report of all setpoint changes listed in the setpoint change log.

Page Up

Scroll up in the displayed data (if applicable).

Page Down

Scroll down in the displayed data (if applicable).

NAVIGATION

Home

Access Level Required: SERVICE

Causes an instant return to the Home Screen.

History

Access Level Required: SERVICE

Causes an instant return to the History Screen.

View Details

Access Level Required: SERVICE

Causes a move to a sub-screen containing the details of the setpoint change selected with the Log Entry Key.

SECURITY LOG DETAILS

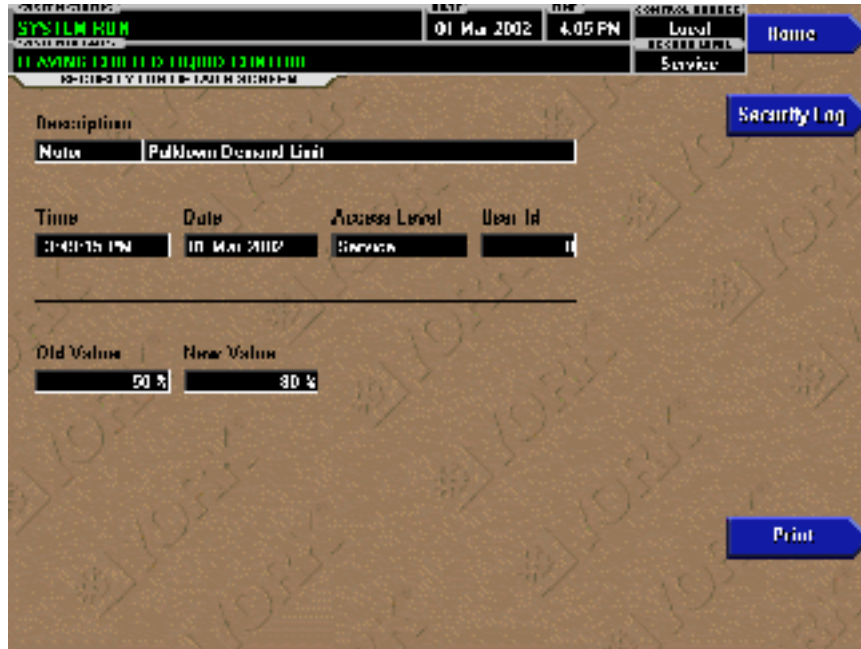

FIG. 27 - SECURITY LOG DETAILS

00649VIP

OVERVIEW

(This screen only available with Flash Memory Card version C.MLM.03.03.xxx and later).

This screen allows the user to view the details of a logged setpoint change, selected from the list on the Security Log Screen. The date and time the setpoint was changed, the new and old setpoint value and access level and user ID used to make the change are displayed. The data on this screen can be printed. **Note: Requires a login access level of SERVICE.**

DISPLAY ONLY

Description

Displays the setpoint/category that was changed.

Time

Displays the time the setpoint was changed.

Date

Displays the date the setpoint was changed.

Access Level

Displays the Login Access Level used to make the setpoint change.

User ID

Displays the User ID used to make the setpoint change.

Old Value

Displays the previous setpoint value.

New Value

Displays the value entered at the time of the setpoint change.

PROGRAMMABLE

Print

Generates a report of change parameters displayed on this screen.

NAVIGATION

Home

Access Level Required: SERVICE

Causes an instant return to the Home Screen.

Security Log

Access Level Required: SERVICE

Causes an instant return to the Security Log Screen.

CUSTOM VIEW SCREEN

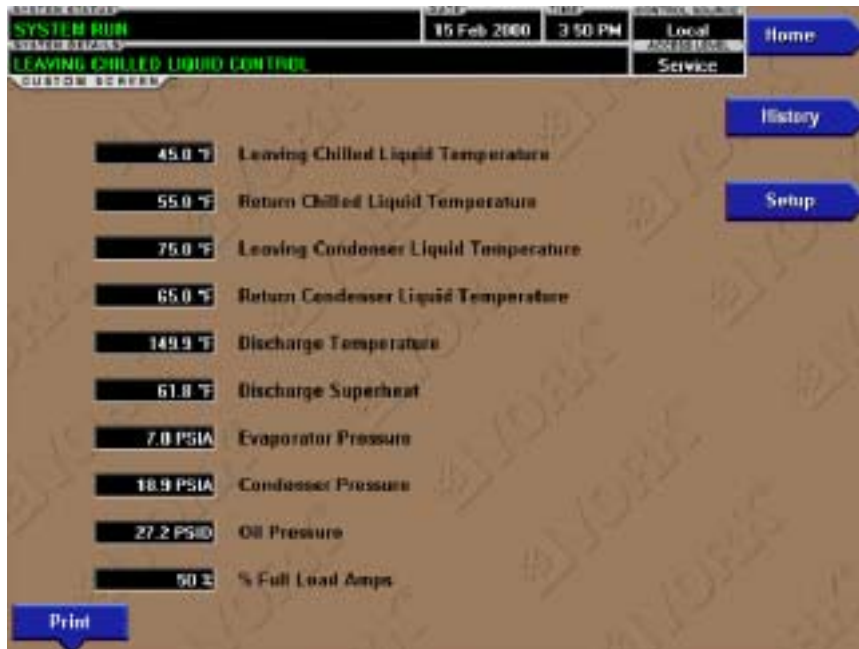

FIG. 28 - CUSTOM VIEW SCREEN

00346VIP

OVERVIEW

This screen allows up to 10 Service Technician selected parameters to be displayed. These parameters are selected from a list on the Custom View Setup Screen. This allows the Service Technician to display parameters pertinent to a particular problem during troubleshooting. At completion of the service call, the display can be cleared or the parameters can be left there for monitoring by operations personnel.

DISPLAY ONLY

None

PROGRAMMABLE

Print

(Flash Memory Card version C.MLM.03.01 or later)

Access Level Required: VIEW

This generates a listing of the parameters displayed on this screen.

NAVIGATION

Home

Access Level Required: VIEW

Causes an instant return to the Home Screen.

History

Access Level Required: VIEW

Causes an instant return to the History Screen.

Setup

Access Level Required: SERVICE

Causes a jump to the sub-screen that allows selection of the parameters to be displayed.

CUSTOM VIEW SETUP

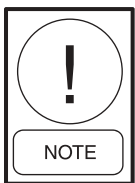

FIG. 29 - CUSTOM VIEW SETUP

00241VIP

OVERVIEW

This screen allows the Service technician to select up to 10 parameters for display on the Custom View Screen.



Requires a login access level of SERVICE. Service Technicians refer to YORK Service Manual 160.80-M1 for operation instructions and explanation of all programmable setpoints and displayed values.

DISPLAY ONLY

Slot Numbers

Lists the available parameters that can be displayed. The desired parameters for display are selected from this list.

PROGRAMMABLE

Page Up

Scroll up through list of available parameters.

Page Down

Scroll down through list of available parameters.

Select

First use the Page Up and Page Down keys to scroll through the Slot Numbers list and note the number of the parameter(s) to be displayed. Pressing the Select key

places a green colored selection box around Custom Slot 1. If it is desired to change an already entered parameter, use the 5 and 6 keys to place the selection box around the slot number to be changed. With the selection box around the slot number to be changed or entered, press the ENTER (✓) key. A dialog box is displayed permitting data entry. Using the numeric keypad keys, enter the desired slot number and press the ENTER (✓) key.

Custom Slot (1-10)

Use the Select key and numeric keypad keys as described above and enter the slot number from Slot Numbers list. Setting the Slot number to zero clears the display of this slot number.

Clear Display

Pressing this key clears all selected parameters from the Custom View screen.

NAVIGATION

Home

Access Level Required: VIEW
Causes a return to the Home Screen.

Custom View

Access Level Required: SERVICE
Causes a return to the Custom View Screen.

This page intentionally left blank

TREND SCREEN



FIG. 30 - TREND SCREEN

00449VIP

OVERVIEW

As many as six Operator selected parameters (Data Points) can be plotted in an X/Y graph format. The X-Axis is scaled per the selected Data Collection Interval and displayed in a time of day or elapsed time format, as selected with the X-axis toggle key. The Y-Axis is scaled for each parameter per the selected minimum and maximum value for each parameter. Analog parameters are scaled in pressure, temperature, volts, amps, hertz or time. Digital on/off parameters are scaled as zero (off) and one (on). Only one Y-Axis label is displayed at a time. The Y-Axis Toggle Key is used to toggle the Y-Axis labels through the different parameters. The Y-Axis label that is being displayed is identified at the top of the graph. For identification, each plotted parameter and associated Y-Axis labeling is color coordinated.

With Flash Memory Card version C.MLM.03.01.xxx and earlier, all trended Data Points are displayed simultaneously. With Flash Memory Card version C.MLM.03.02.xxx and later, the DATA SELECT key is used to display all trended Data Points simultaneously or select a single Data Point for display.

The parameters are sampled at the selected Data Collection Interval and plotted using 450 data points across the X-Axis. If the actual value of the sampled parameter is less than the Y-Axis label minimum for that parameter,

the value will be plotted at the minimum value. Similarly, if the actual value is greater than the Y-Axis label maximum for that parameter, the value will be plotted at the maximum value.

There are three types of charts that can be created: **ONE SCREEN, CONTINUOUS** or **TRIGGERED** (not applicable to Flash Memory Card version C.MLM.03.01.xxx and earlier). When plotting reaches the end of the X-axis, if ONE SCREEN is selected, trending stops and data is frozen. If CONTINUOUS is selected, the oldest data is dropped from the left-hand side of the graph at the next collection interval. Thereafter, the oldest data is dropped from the left hand-side of the graph at each data collection interval. If TRIGGERED is selected, data collection can be set to start or stop based upon the selected TRIGGER ACTION (START or STOP). If START is selected, data collection will not begin until the Triggers have been satisfied and any selected TRIGGER DELAY has elapsed. Data collection will stop at the completion of one screen of data as with the ONE SCREEN. If STOP is selected, data collection will not stop until the Triggers have been satisfied and any selected TRIGGER DELAY has elapsed.

If a power failure occurs while the trending is running, the trending is stopped. Upon restoration of power, the last screen of data that was collected will be displayed on the trending screen. The START key must be pressed to initiate a new trend screen.

DISPLAY ONLY

This screen allows the user to view the graphical trending of the selected parameters and is also a gateway to the graph setup screens.

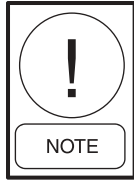

A red screen with the words “TREND MAX MUST BE > TREND MIN” will appear if the Y-Axis minimum has been programmed to a value that is greater than the Y-Axis maximum for any parameter. If this appears, proceed to the Trend Setup Screen to change the values.

PROGRAMMABLE

Start

Access Level Required: OPERATOR

Pressing this key clears the graph, starts a new graph, sets the time of day to the present clock time and begins the trending. This key is only available if trending is stopped. If the selected Chart Type is TRIGGERED and TRIGGER ACTION is set to START, data collection will not begin until the Triggers have been satisfied and any selected TRIGGER DELAY has elapsed. Otherwise, data collection will begin immediately.

Stop

Access Level Required: OPERATOR

Pressing this key stops the trending. The trend data is frozen on the display until another graph is started with the START key. The STOP key is only available if trending is running.

Data Select

(Flash Memory Card version C.MLM.03.02.xxx and later)

Access Level required: VIEW

Allows the user to display all trended data points simultaneously or select a single trended data point for display, hiding the other data points. Selections are ALL DATA or DATA POINT X (1-6).

Print

(Flash Memory Card version C.MLM.03.02.xxx and later)

Access Level Required: VIEW

Allows the data on the trend screen to be printed in tabular format. If set to EXISTING, a snapshot of the data presently on the screen is sent to the printer. If set to NEW, all data collected after pressing this key will be sent to the printer as it is collected. If set to DISABLED, no data is sent to the printer. Refer to PRINTERS section of this book for printout example.

Y-Axis

Access Level Required: VIEW

This key toggles the Y-Axis labels of the graph. Each key press changes the label to another of the selected parameters.

X-Axis

Access Level Required: VIEW

This key toggles the X-Axis labels of the graph. Each key press alternates the scaling between time of day and elapsed time. The Time of Day scaling is in 24-hour format. The Elapsed Time scaling is the time elapsed since the START key was pressed, starting the trending.

NAVIGATION

Home

Access Level Required: VIEW

Causes a return to the Home Screen.

History

(Flash memory Card version C.MLM.03.01.xxx and earlier)

Access Level Required: VIEW

Causes a return to the History Screen.

Trend Setup

Access Level Required:

Only displayed if the trending is stopped. Causes a jump to a sub-screen for configuring the trending display.

TREND SETUP SCREEN



FIG. 31 - TREND SETUP SCREEN

00450VIP

OVERVIEW

This screen is used to configure the trending screen. The parameters to be trended are selected from the Common Slots Screen or Common Slots Master list and entered as Slot Numbers for Data Points 1 through 6. The Y-Axis minimum and maximum values for each parameter are entered as Data Point Min and Data Point Max for Data Points 1 through 6. The interval at which all the parameters are sampled is selected as the Data Collection Interval.

DISPLAY ONLY

None

PROGRAMMABLE**Chart Type**

Access Level Required: OPERATOR

Selects CONTINUOUS, ONE SCREEN or TRIGGERED (Flash Memory Card version (C.MLM.03.02.xxx and later) type of graph.

Collection Interval

Access Level Required: OPERATOR

Selects the interval at which the parameters are sampled. There are 450 data points displayed across the X-Axis of the graph. Each point represents the instantaneous value of the parameter. The user selects the time interval

between these points. This is called the DATA COLLECTION INTERVAL, or the interval at which the parameter is sampled. This interval is programmable over the range of 1 second to 3600 seconds (1 hour), in one second increments. The selected interval not only determines the sample interval, but also the full screen time display. The full screen time display is a result of the selected interval in seconds, multiplied by the 450 data points. For example, if the **Data Collection Interval** is programmed for 900 seconds, the parameter would be sampled every 900 seconds, with the last 112.5 hours (4.7 days) of data viewable on the screen. Therefore, the selected interval is a compromise between resolution and full screen time display. Select the desired **Data Collection Interval** as follows:

1. Determine the desired time interval (in seconds), between data samples.
2. Calculate the full screen time display as follows:
 - $450 \times \text{Data Collection Interval} = \text{full screen seconds}$
 - $\text{full screen seconds} / 60 = \text{full screen minutes}$
 - $\text{full screen minutes} / 60 = \text{full screen hours}$
 - $\text{full screen hours} / 24 = \text{full screen days}$
3. Decide if the resultant sample interval and full screen display meet the requirements. If not, select a different sample interval.

Select

Access Level Required: OPERATOR

This key is used to enter the slot numbers and the minimum and maximum Y-Axis values of each parameter to be trended. Pressing this key places a yellow box around Data Point 1 Slot Number. ▲ and ▼ navigation keys to place the box around the value of Data Points 1 through 6 to be changed. With the desired value selected, press the ✓ key. A dialog box is displayed permitting data entry.

Data Point Slot # (1-6)

Access Level Required: OPERATOR

Use the SELECT key as described above and enter the slot number from the Common Slots Screen or Master Slot Number List of the desired parameter to be trended. The selected parameter description will be displayed for the Data Point. Setting this slot number to zero will disable trending for that particular Data Point. Any or all points can be disabled.

Data Point Min (1-6)

Access Level Required: OPERATOR

Only displayed if the Associated Slot Number is not Zero. This is the minimum value displayed for the Y-Axis. Selecting a parameter for a Data Point sets this to the default value, which is the lowest value allowed for that parameter. It can be changed to a value that provides a more appropriate resolution for the parameter being monitored. To change, use the SELECT key as described above and enter the desired value. The value must always be set to a value less than the Data Point Max. Otherwise, a red graph is displayed on the Trend Screen with the words “**TREND MAX MUST BE > TREND MIN**”. If the parameter selected for this data point is a digital type (on/off), this value must be set to zero (0). Zero indicates the OFF state.

Data Point Max (1-6)

Access Level Required: OPERATOR

Only displayed if the associated slot number is not zero.

This is the maximum value displayed for the Y-Axis. Selecting a parameter for a Data Point sets this to the default value, which is the highest value allowed for that parameter. It can be changed to a value that provides a more appropriate resolution for the parameter being monitored. To change, use the **SELECT** key as described above and enter the desired value. The value must always be set to a value greater than the Data Point Min. Otherwise, a red graph is displayed on the Trend Screen with the words “**TREND MAX MUST BE > TREND MIN**”. There are 20 Y-axis divisions. If a MIN-MAX span is selected that is not evenly divided by 20, the Program will automatically select the next higher MAX value that makes the span evenly divided by 20. For example, if 0.0 is selected as the MIN, and 69.0 as the MAX, the Program will insert 70.0 as the MAX value. If the parameter selected for this data point is a digital type (on/off), this value must be set to one (1). One indicates the on state.

NAVIGATION**Home**

Causes a return to the Home Screen.

Trending

Causes a return to the Trending Screen.

Slot Numbers

Causes a jump to a sub-screen that lists the slot numbers of the most commonly monitored parameters. The desired parameters to be plotted are selected from this screen.

Triggers

(Flash Memory Card version C.MLM.03.02.xxx and later)

Causes a jump to the Advanced Trend Setup Screen, where the start/stop Triggers can be setup. Only displayed if TRIGGERED has been selected as Chart Type.

ADVANCED TREND SETUP SCREEN



FIG. 32 - ADVANCED TREND SETUP SCREEN

00451VIP

OVERVIEW

(Flash Memory Card version C.MLM.03.02.xxx and later)

The desired data collection start/stop triggers are setup on this screen. The trend data collection can be set to start or stop based upon the status of up to two selected Triggers. The Triggers can consist of digital events or analog parameters compared to thresholds. The Triggers can be used individually or in combination. The digital and analog parameters are selected from the Common Slots Screen (or Master Slot Numbers List in this book).

The parameter selected as the Primary Trigger is compared to a value selected as the Primary Test, using the Primary Operator as a comparator. If it is evaluated as true, then the data collection is started or stopped (after any selected Trigger delay) per the selected Trigger Action.

A Secondary Trigger can be evaluated with the Primary Trigger to start/stop data collection. The Primary to Secondary Operator is used to define the Trigger combinations required to be true to start/stop data collection. The Secondary Trigger is setup and evaluated the same as the Primary Trigger. Entry fields are as follows:

If Primary Trigger
Is Primary Operator Primary Test

Primary to Secondary Operator

Secondary Trigger
Is Secondary Operator Secondary Test

Then Trigger Action the Data Collection
With a delay of Trigger Delay

After the desired Triggers are set, the START key on the TREND Screen must be manually pressed before the triggers will be evaluated. While waiting for the triggers to start or stop data collection, a status message is displayed in the upper right corner of the TREND Screen describing the pending action.

DISPLAY ONLY

None

PROGRAMMABLE

Primary Trigger

Access Level Required: OPERATOR

Selects the first parameter to be evaluated. Selection is made from the Slot Numbers listing on the Trend Com-

mon Slots Screen or the Master Slot Numbers List in this book. Setting this slot number to zero disables the Primary Trigger.

Primary Operator

Access Level Required: OPERATOR

Selects the comparator for the Primary Trigger's relationship to the Primary Test. If the Primary Trigger is an analog value, selections are: <, <=, =, =>, >. If the Primary Trigger is a digital event, selections are: Equal To, Not Equal To.

Primary Test

Access Level Required: OPERATOR

Selects the value or condition that the Primary Trigger is compared to. Selection ranges from the Primary Trigger minimum value to the Primary Trigger maximum value.

Trigger Action

Access Level Required: OPERATOR

Selects whether the trend data collection will Start or Stop when the Trigger comparisons are true. If set to Start, data collection will stop after one screen of data is collected.

Trigger Delay

Access Level Required: OPERATOR

Allows the data collection start or stop to be delayed after the Triggers evaluate as true. The delay is selectable from 1 to 864000 seconds (10 days). Display is in days, hours, minutes and seconds. The delay timer begins when the triggers evaluate as true. If the Trigger Action is set to Start, data collection will begin after the triggers evaluate as true and the delay timer has elapsed. If the Trigger Action is set to Stop, data collection will stop after the Triggers evaluate as true and the delay timer has elapsed.

Primary to Secondary Operator

Access Level Required: OPERATOR

Selects whether the Primary Trigger, Secondary Trigger or both have to be true in order to start or stop data

collection. Selections are AND, OR, XOR and None. If NONE is selected, the Secondary Trigger is disabled.

Data collection will start/stop (as selected with Trigger Action) when:

- If AND selected: Both Primary AND Secondary are true
- If OR selected: Either Primary OR Secondary (or both) are true
- If XOR selected: Either Primary OR Secondary (but not both) are true

Secondary Trigger

Access Level Required: OPERATOR

Selects the second parameter to be evaluated. Selection is made from the Slot Numbers listing on the Trend Common Slots Screen or the Master Slot Numbers List in this book. Setting this slot number to zero disables the Secondary Trigger.

Secondary Operator

Access Level required: OPERATOR

Selects the comparator for the Secondary Trigger's relationship to the Secondary Test. If the Secondary trigger is an Analog value, selections are: <, <=, =, =>, >. If the Secondary Trigger is a digital event, selections are: Equal To, Not Equal To.

Secondary Test

Access Level Required: OPERATOR

Selects the value or condition that the Secondary Trigger is compared to. Selection ranges from the Secondary Trigger minimum to the Secondary Trigger maximum.

NAVIGATION

Home

Causes an instant return to the Home Screen.

Trend Setup

Causes an instant return to the Trend Setup Screen.

COMMON SLOTS SCREEN



FIG. 33 - COMMON SLOTS SCREEN

00244VIP

OVERVIEW

This screen displays the slot numbers of the commonly monitored parameters. The slot numbers for the remainder of the available parameters are listed on the Master Slot Numbers List that follows.

From these lists, select up to six parameters to be trended. Return to the Trend Setup Screen and enter the parameters Slot Numbers into Data Points 1 through 6.

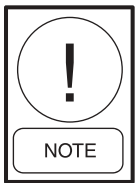

Requires a login access level of OPERATOR or higher.

DISPLAY ONLY**Slot Numbers**

These are the slot numbers of the most commonly used parameters.

PROGRAMMABLE**Page Down**

Access Level Required: OPERATOR
Scroll down in the displayed data.

Page Up

Access Level Required: OPERATOR
Scroll up in the displayed data.

Print

Access Level Required: OPERATOR
Generates a list of the slot numbers of the available parameters.

NAVIGATION**Home**

Causes an instant return to the Home Screen.

Trend Setup

Causes a return to the Trend Setup Screen.

MASTER SLOT NUMBERS LIST FOR USE WITH TREND FEATURE

SLOT NO.	DESCRIPTION	SLOT NO.	DESCRIPTION
256	System: Chiller State	1800	Leaving Chilled Liquid: Selected Temperature Setpoint
259	System: Are Safety Shutdown Contacts Closed	1801	Leaving Chilled Liquid: Control Sensitivity
260	System: Are Cycling Shutdown Contacts Closed	1802	Leaving Chilled Liquid: Remote Temperature Range
261	System: Are Anticipatory Alarm Contacts Closed	1803	Leaving Chilled Liquid: Restart Temperature Offset
262	System: Operating Hours	1804	Leaving Chilled Liquid: Restart Temperature Setpoint
264	System: Number of Starts	1805	Leaving Chilled Liquid: Shutdown Temperature Offset
265	System: Is Stop Switch Closed	1806	Leaving Chilled Liquid: Shutdown Temperature Setpoint
266	System: Is Start Switch Closed		
267	System: Is Remote Ready to Start	1807	Return Chilled Liquid: Temperature
280	External Contact: Is Remote Stop Closed	1808	Evaporator: Pressure
281	External Contact: Is Remote Start Closed	1809	Evaporator: Saturation Temperature
282	External Contact: Is MultiUnit Cycling Closed	1810	Evaporator: Small Temperature Difference
283	External Contact: Is Remote Cycling Closed	1811	Evaporator: Is Refrigerant Sensor Present
284	External Contact: Is Auxiliary Safety Open	1812	Evaporator: Refrigerant Temperature
285	Dipswitch: Is Anti-Recycle Enabled	1813	Evaporator: Delta P / P
287	Dipswitch: Is Diagnostics Enabled		
288	Jumper: Liquid Type	1815	Smart Freeze Protection: Is Control Enabled
289	Dipswitch: Chilled Liquid Pump Operation		
290	Jumper: Motor Type	1818	Leaving Chilled Liquid: Remote Digital Temperature Setpoint
291	Dipswitch: Power Failure Restart	2048	Leaving Condenser Liquid: Temperature
293	Jumper: Refrigerant Selection	2049	Leaving Condenser Liquid: Is Flow Switch Closed
304	Options: Control Mode	2050	Leaving Condenser Liquid: Is Pump On
305	Options: System Language	2051	Return Condenser Liquid: Temperature
306	Options: Chiller ID Number		
307	Options: Display Mode	2052	Condenser: Pressure
336	Security: Log In Level	2053	Condenser: Saturation Temperature
337	Security: Log In User ID	2054	Condenser: Small Temperature Difference
512	Sched: Is Schedule Enabled	2057	Condenser: Is High Pressure Switch Closed
1296	Discharge: Temperature	2058	Condenser: High Pressure Warning Threshold
1298	Discharge: Superheat Temperature	2059	SubCooling: Temperature
1543	Oil Return Solenoid: Is Solenoid On	2304	Motor: Starter Type
1792	Leaving Chilled Liquid: Temperature	2305	Motor: Is Motor Starter On
1793	Leaving Chilled Liquid: Temperature Differential	2306	Motor: Current %FLA
1794	Leaving Chilled Liquid: Is Flow Switch Closed	2307	Motor: Is Motor Controller Switch Open
1795	Leaving Chilled Liquid: Is Pump On		
1796	Leaving Chilled Liquid: Local Temperature Setpoint	2308	Motor: Current Limit Local Setpoint
1797	Leaving Chilled Liquid: Remote Analog Temperature Setpoint	2309	Motor: Current Limit Remote Analog Setpoint
1798	Leaving Chilled Liquid: Remote ISN Temperature Setpoint	2310	Motor: Current Limit Remote ISN Setpoint
1799	Leaving Chilled Liquid: Remote Modem Temperature Setpoint	2311	Motor: Current Limit Remote Modem Setpoint
		2312	Motor: Current Limit Selected Setpoint

SLOT NO.	DESCRIPTION
2313	Motor: Pulldown Demand Time Remaining
2314	Motor: Pulldown Demand Limit Setpoint
2315	Motor: Pulldown Demand Time Setpoint
2316	Motor: Anti-Recycle Time Remaining
2317	Motor: Current Limit Remote Digital Setpoint
	Mod "A" SSS Only
2560	SSS: Phase A Current
2561	SSS: Phase B Current
2562	SSS: Phase C Current
2563	SSS: Phase A Voltage
2564	SSS: Phase B Voltage
2565	SSS: Phase C Voltage
2566	SSS: Scale/Model
2567	SSS: Full Load Amps
2568	SSS: Supply Voltage Range
2569	SSS: Is Current Unbalance Check Enabled
	Mod "B" SSS Only
2570	Serial SSS: Input Power
2571	Serial SSS: Kilowatt Hours
2572	Serial SSS: Phase A Current
2573	Serial SSS: Phase B Current
2574	Serial SSS: Phase C Current
2575	Serial SSS: Phase A Voltage
2576	Serial SSS: Phase B Voltage

SLOT NO.	DESCRIPTION
2577	Serial SSS: Phase C Voltage
2578	Serial SSS: Phase A Temperature
2579	Serial SSS: Phase B Temperature
2580	Serial SSS: Phase C Temperature
2581	Serial SSS: Starter Model
2582	Serial SSS: Full Load Amps
2583	Serial SSS: Voltage Range
2584	Serial SSS: Starting Current
2585	Serial SSS: Is Serial Communications OK
2586	Serial SSS: Panel to Sss Comm Errors
2587	Serial SSS: to Panel Comm Errors
16388	Slide Valve: Position
16401	Oil: Pressure
16402	Oil: Differential Pressure
16404	Seal Oil: Pressure
16405	Seal Oil: Differential Pressure
16406	Filter Oil: Pressure
16407	Filter Oil: Differential Pressure
16409	Oil Separator: Temperature
16410	Variable Orifice: Delta P (Cond-Evap)
16412	Variable Orifice: Is Solenoid On
16415	Hot Gas Bypass: Is Solenoid On

DISPLAY MESSAGES

The Status Bar of the Display contains a Status Line and, beneath it a Details Line. The Status Line contains a message describing the operating state of the chiller; whether it is stopped, running, starting or shutting down. The Details Line displays Warning, Cycling, Safety, Start Inhibit and other messages that provide further details of the Status Bar messages. The **Status Messages** listed below are displayed on the Status Line. All other messages are displayed on the Details Line.

To aid in the meaning of the message, messages are displayed in different colors as follows:

- Normal Operation messages - Green
- Warning messages - Yellow
- Cycling Shutdown messages - Orange
- Safety Shutdown messages - Red

Note that there are three types of shutdowns. If the chiller shuts down on a CYCLING shutdown, it will automatically restart when the condition that caused the shutdown no longer exists. SAFETY shutdowns require the operator to perform a manual reset at the keypad. A NORMAL shutdown occurs from a properly requested or scheduled shutdown. The event that caused the shutdown is displayed on the Details Line.

STATUS MESSAGES

“SYSTEM READY TO START”

The chiller is shut down but will start upon receipt of a Local or Remote start signal.

“CYCLING SHUTDOWN – AUTO RESTART”

The chiller is shut down on a CYCLING shutdown. The cause of the shutdown is still in effect and is displayed on the Details line of the Status Bar. The chiller will automatically restart when the CYCLING condition clears.

“SAFETY SHUTDOWN – MANUAL RESTART”

The chiller is shut down on a SAFETY shutdown. The cause of the shutdown is still in effect and is displayed on the Details line of the Status Bar. The chiller can be started after the Safety condition clears and the Operator moves the COMPRESSOR switch to the STOP-RESET (O) position.

“START SEQUENCE INITIATED”

A chiller start has been initiated. The oil line solenoid valve 1SOL (125-400TR chillers only) is energized

(opened) for 15 seconds. During this 15 seconds period, the pressure transducer AUTO-ZEROING sequence is performed unless it was disabled.

“SYSTEM RUN”

The chiller is running under the condition described in the Details Line of the Status Bar.

“START INHIBIT”

The chiller is prevented from being started due to the reason displayed on the Details Line of the Status bar.

“SLIDE VALVE CLOSING BEFORE SHUTDOWN”

To assure the Slide Valve unloads to < 30% position during shutdown, it is unloaded to < 30% prior to shutting down the chiller on certain shutdowns.

While the chiller is running, if one of the below listed shutdown commands occur and the slide valve position is > 30%, a continuous unload signal is applied to the slide valve until its position is < 30%. While the slide valve is unloading this status message is displayed. The event that caused the shutdown is displayed on the Details Line. When the slide valve position becomes < 30%, the chiller shuts down and the normal 2-minute lockout period begins. The shutdown commands that initiate this operation are:

- MULTIUNIT CYCLING - CONTACTS OPEN
- SYSTEM CYCLING - CONTACTS OPEN
- REMOTE STOP
- LEAVING CHILLED LIQUID - LOW TEMPERATURE
- CONTROL PANEL - SCHEDULE

To assure that a defective slide valve actuator or mechanical problems cannot prevent a chiller shutdown, if the slide valve has not unloaded to < 30% within 210 seconds of receiving the shutdown command, a shutdown occurs regardless of slide valve position. If the chiller start is initiated and the slide valve is still >30%, the “START INHIBIT” status message is displayed and the message “SLIDE VALVE - POSITION > 30%” is displayed on the detail line.

“SYSTEM LOCKOUT DELAY”

Anytime the chiller shuts down for any reason, it cannot be restarted for 2 minutes. This message is displayed during that time. This is so the refrigerant in the system settles and the evaporator and condenser pressure equalize.

RUN MESSAGES

“LEAVING CHILLED LIQUID CONTROL”

The chiller is running, controlling the Leaving Chilled Liquid to the Leaving Chilled Liquid Temperature Setpoint. There are no system conditions inhibiting this operation.

“MOTOR-PULLDOWN LIMIT”

The Pulldown Demand Limit Setpoint timer is in effect and the Compressor Motor current is \geq the Pulldown Demand Current Limit Setpoint value. The slide valve operation is being inhibited as described in “MOTOR – HIGH CURRENT LIMIT” message below.

“MOTOR - HIGH CURRENT LIMIT”

The Compressor Motor Current is \geq the Local or Remote Current Limit Setpoint. The Current Limit Setpoint is programmed over a range of 30% to 100% of the Chiller Full Load Amps (FLA). When the motor current increases to the “inhibit load” threshold, the slide valve is inhibited from further loading. This prevents a further current rise. If the current continues to rise to the “start unload” threshold, the slide valve begins unloading until the current falls to the “stop unload” threshold. Automatic Slide Valve operation is resumed and this message automatically clears when the motor current decreases to the “allow load” threshold. To allow field calibration of the Solid State Starter (Mod “A”) Logic Board or CM-2 Current Module, pressing the Slide Valve Load key in Service access level, starts a 10 minute timer during which the current limit thresholds are elevated. Refer to the following table.

Slide Valve Control	Motor Current (%FLA)	
	All Other Modes	Service Mode
On rise, inhibit load	100	107
On fall, allow load	98	106
On rise, start unload	104	110
On fall, stop unload	102	109

An example of current limit is as follows: If a Solid State Starter chiller FLA is 100 Amps and the Current Limit Setpoint is 50%, the following will occur:

- 50 Amps - inhibit slide valve load
- 52 Amps - slide valve begins unloading
- 51 Amps - slide valve stops unloading
- 49 Amps - allow automatic slide valve control

“MAXIMUM LOAD - LOAD LIMIT”

Displayed if the special Maximum Load Limit Setpoint is limiting the Slide Valve loading. This special setpoint is used to prevent overloading the Oil Separator on certain compressor/chiller combinations operating at extreme conditions. It limits the compressor motor current to 60% to 100% (as programmed) until the Leaving Chilled Liquid Temperature is $< 50.0^{\circ}\text{F}$ to 70.0°F (as programmed) after 3 minutes of operation. Service Technicians refer to YORK Service manual 160.80-M1.

“MINIMUM LOAD - LOAD LIMIT”

Displayed while Slide Valve unloading is being limited by the selected control source (Slide Valve or Motor FLA). If “Slide Valve” is selected, the minimum allowed slide valve position is 15%. If “Motor FLA” is selected, the minimum allowed slide valve position is that which will maintain the motor current above the programmed value (15% to 70% FLA). Regardless of which method is selected, if the Slide Valve position falls below the minimum allowed position, a 1 second load pulse is applied every 3 seconds until it meets the minimum allowed position. The control source is selected by a Service Technician using instructions in YORK Service manual 160.80-M1.

START INHIBIT MESSAGES

“ANTI-RECYCLE XXMin/Sec”

The chiller is inhibited from starting because the 30 minute anti-recycle time has not yet elapsed. Time remaining is displayed.

“SLIDE VALVE - POSITION > 30%”

The chiller is inhibited from starting because the slide valve did not properly unload. This could be the result of a defective slide valve actuator or mechanical problem.

“MOTOR CURRENT >15% FLA”

The Control center has detected a Compressor Motor Current of a magnitude that is $>15\%$ of the chiller Full Load Amps for 10 continuous seconds, while the chiller is shutdown. As long as this condition exists, the oil pump is turned on. This is generally indicative of a failure of the motor starter, Control Center start circuits or motor current feedback circuits. After motor current is no longer detected, a SYSTEM LOCKOUT DELAY is performed. The chiller can be started after motor current is no longer detected, the SYSTEM LOCKOUT DELAY has completed and the COMPRESSOR switch is placed in the STOP-RESET (O) position.

“LCSSS - HIGH TEMPERATURE PHASE X - STOPPED”

(Mod. “B” Solid State Starter only)

The chiller is stopped and the Liquid Cooled Solid State Starter Logic/Trigger Board has detected that the temperature of phase A, B, or C (designated as X in this message) Silicon Controlled Rectifier (SCR) module is > 110°F. The starter cooling pump will run and the chiller will be inhibited from starting until the temperature decreases to <109°F.

WARNING MESSAGES

“WARNING – REAL TIME CLOCK FAILURE”

During the initialization process that occurs when power is applied to the Control Center, test data is written to a location in the BRAM battery backed memory device (IC location U52 on Micro Board). This data is then read from the BRAM and compared to the test data. If the read data is not the same as that which was written to the device, it is assumed the BRAM and Real time Clock operation is defective and this message is displayed. The BRAM should be replaced by a qualified Service Technician. This message automatically clears when the BRAM problem has been solved.

“WARNING – SETPOINT OVERRIDE”

A blank BRAM battery-backed memory device (IC location U52 on Micro Board) or a failure of this device was detected during the initialization process that occurs when power is applied to the Control Center. Due to this failure, any or all of the programmed Setpoints could have been corrupted. Therefore, all Setpoints have been automatically changed to their Default values. All Setpoints will have to be programmed to their desired values. This message will clear when the WARNING RESET key is pressed in OPERATOR (or higher) access mode.

“WARNING – CONDENSER – HIGH PRESSURE LIMIT”

The Condenser Pressure exceeds the High Pressure Warning Setpoint threshold, programmed by a Service technician logged in at SERVICE access level. While this condition is in effect, the Slide Valve is inhibited from further loading. This message automatically clears and the Slide Valve is permitted to load when the Condenser pressure decreases to 5 PSIG below the Setpoint.

“WARNING – EVAPORATOR – LOW PRESSURE LIMIT”

The Evaporator pressure has decreased to the Warning

threshold. This threshold is fixed in Water cooling applications. In Brine cooling applications, the threshold is a fixed amount above the programmable safety shutdown threshold. The Safety threshold in Brine applications is determined by the Brine solution and is determined by the YORK Factory. While this condition is in effect, the Slide Valve is inhibited from further loading. This message automatically clears and the Vanes are permitted to open when the Evaporator pressure increases to the reset value.

	Warning Threshold (PSIG)		Reset Threshold (PSIG)	
	Water	Brine	Water	Brine
R22	56.2	+1.9 >Safety Setpoint	57.5	+3.2>Safety Setpoint
R134a	27.0	+2.0 >Safety Setpoint	28.0	+3.0>Safety Setpoint

“WARNING – FREEZE THREAT FROM OPERATING CHILLER”

Displayed after the chiller has been shutdown for at least the amount of time programmed as the Freeze Warning Bypass Setpoint (programmed by a Service technician logged in at Service access level) and the Condenser Saturation Temperature decreases to <28°F. When the temperature increases to >28° F, the warning message clears.

“WARNING – FREEZE THREAT, CONDENSER FLOW SWITCH OPEN”

If the Standby Chiller Freeze Protection is enabled, the Control Center operates the Condenser Water Pump during Freeze Threat situations, while the chiller is shutdown. This message is displayed if the Condenser Water Flow Switch does not close within 60 seconds of condenser pump start or it opens for 2 continuous seconds after the 60 second start bypass. This message will clear when the WARNING RESET key is pressed in OPERATOR (or higher) access level.

“WARNING – LOW DISCHARGE SUPERHEAT LIMIT”

If the chiller has been running for at least 3 minutes and the Discharge Superheat is ≤ 10.0°F (R22), 5.0°F (R134a), this message is displayed and the slide valve is inhibited from loading. If this condition exists continuously for 10 seconds, the Slide valve is driven with 0.5 second unload pulses, applied every 3.5 seconds until the Discharge Superheat is ≥ 15.0°F (R22), 10.0°F (R134a), whereupon this message is replaced with “WARNING – LOW DISCHARGE SUPERHEAT DETECTED”. “WARNING – LOW DISCHARGE SUPERHEAT DETECTED” Refer to “WARNING - LOW DISCHARGE SUPERHEAT LIMIT” message above. This message

will clear when the Warning reset key is pressed in OPERATOR (or higher) access level.

“WARNING – OIL - DIRTY FILTER”

Displayed if the oil filter differential pressure exceeds 20 PSID for 8 continuous seconds. This message automatically clears when the condition clears.

“WARNING – OIL - HIGH TEMPERATURE”

Displayed when the oil temperature rises to 165°F. This message automatically clears when the temperature decreases to $\leq 160^\circ\text{F}$.

“WARNING – SLIDE VALVE UNCALIBRATED”

The slide valve position potentiometer calibration has not yet been performed. This message automatically clears when the calibration has been performed.

“WARNING – OIL RECOVERY LIMIT”

(Flash Memory Card version C.MLM.03.03.xxx & later)

Displayed while the Oil Recovery feature is limiting the Slide Valve Loading. This load limiting will be in effect if the chiller has been running for more than 3 minutes and the Discharge Superheat is [$<25.0^\circ\text{F}$ (R22)(13.0°F for R134a) but $>10.0^\circ\text{F}$ (R22)(5.0°F for R134a)] or the slide valve position is $<40\%$. This load limiting remains in effect until both the Discharge Superheat increases to $\geq 25.0^\circ\text{F}$ (R22)(13.0°F for R134a) and the Slide Valve position increases to $\geq 40\%$, whereupon this message is automatically cleared. Refer to Section 1 (Chiller Operation Overview) for details of the Load limiting. If the Discharge Superheat decreases to 10.0°F (5.0°F for R134a) or less, the “Warning – Low Discharge Superheat Limit” routine is invoked and replaces the “Warning – Oil Recovery limit” message. The Oil Recovery feature is enabled or disabled on the Oil Separator Screen.

ROUTINE SHUTDOWN MESSAGES

“REMOTE STOP”

A shutdown command has been received from a remote device. Remote Stop commands can be received in Digital Remote mode via I/O Board TB4-7/8 or in ISN (Integrated Systems Network) Remote mode via the Microgateway serial communications. If the chiller is running when this occurs, the Pre-rotation Vanes are driven fully closed prior to shutting down the chiller.

“LOCAL STOP”

A local shutdown command has been received by placing the Keypad Start-Run-Stop/Reset Switch in the stop (O) position.

“PLACE COMPRESSOR SWITCH IN RUN POSITION”

The Control Center is in either Digital or ISN (Integrated Systems Network) Remote mode. The Operator is requested to place the COMPRESSOR Switch in the RUN position. The Control Center will not accept a Remote start/stop command unless the switch is in the RUN position.

CYCLING SHUTDOWN MESSAGES

“MULTIUNIT CYCLING – CONTACTS OPEN”

The Multiunit Cycling contacts connected to I/O Board TB4-9, have opened to initiate a cycling shutdown. If the chiller is running when this occurs, the Slide Valve is fully unloaded prior to shutting down the chiller. The chiller will automatically restart when the contacts close.

“SYSTEM CYCLING – CONTACTS OPEN”

The System Cycling contacts connected to I/O Board TB4-13, have opened to initiate a cycling shutdown. If the chiller is running when this occurs, the slide valve is fully unloaded prior to shutting down the chiller. The chiller will automatically restart when the contacts close.

“CONTROL PANEL – POWER FAILURE”

A Control Power failure has occurred. If the power failure occurred while the chiller was running, it will automatically restart when power is restored. This message can indicate a Cycling (auto-restart after power failure) or Safety (manual restart after power failure) shutdown, depending upon Control Center configuration. It indicates a cycling shutdown when displayed in orange characters; Safety shutdown when displayed in red characters. The Control Center is configured for auto-restart or manual restart after power failure by a qualified Service Technician following instructions in YORK Service Manual 160.80-M1.

“LEAVING CHILLED LIQUID – LOW TEMPERATURE”

The Leaving Chilled Liquid Temperature has decreased to the programmed Shutdown Temperature Setpoint. If the chiller is running when this occurs, the Slide Valve is fully unloaded prior to shutting down the chiller. The chiller will automatically restart when the temperature increases to the programmed Restart Temperature Setpoint.

“LEAVING CHILLED LIQUID – FLOW SWITCH OPEN”

The Chilled Liquid Flow Switch has remained open for 2 continuous seconds while the chiller was running or failed to close during the Start Sequence Initiated period. The chiller will automatically restart when the flow switch closes.

“CONDENSER – FLOW SWITCH OPEN”

The Condenser water flow switch has remained open for 2 continuous seconds while the chiller was running. This check is bypassed for the first 30 seconds of “System Run”. The chiller will automatically restart when the flow switch closes.

“MOTOR CONTROLLER – CONTACTS OPEN”

The CM-2 Current module (Electromechanical starter applications) or Mod “A” Solid State Starter Logic Board (Solid State Starter applications) has shutdown the chiller. When detecting a fault condition that places the starter or motor at risk, these devices open the Motor Controller contacts “CM” (located on the respective device and connected between TB6-16 and TB6-53 in the Control Center) to initiate a shutdown. Since there are several different faults that are monitored, LED’s on the respective device illuminate to identify the specific fault that has occurred. The chiller will automatically restart when the Motor Controller contacts close. On some shutdowns, the respective device automatically closes the contacts when the fault condition clears. Other shutdowns require the Operator to perform a Manual Reset at the respective device.

Device	Manual Reset Fault	Automatic Reset Fault
CM-2 Module	Overload	None
Mod “A”	Overload	Phase Rotation/Loss
Solid State Starter	High Temp(>212° F)	High Temp start inhibit (>110° F)
	Fault Current	Trigger Board Out-of-Lock

“MOTOR CONTROLLER – LOSS OF CURRENT”

The Compressor Motor current decreased to 10% Full Load Amps (FLA) for 25 continuous seconds while the chiller was running. This could be caused by the starter de-energizing during run or a defect in the motor current feedback circuitry to the Control Center. The chiller will automatically restart at the completion of “System Coastdown”.

“POWER FAULT”

The CM-2 Current Module (Electro-mechanical starter applications) or Mod “A” Solid State Starter Logic Board (Solid State Starter applications) has shutdown the chiller because it detected a fault condition that places the motor at risk. These devices open and close the Motor controller “CM” contacts (located on the respective device and connected between TB6-16 and TB6-53 in the Control Center) in < 3 seconds to initiate the shutdown and produce this message. An LED on the respective device illuminates to identify the specific fault that has occurred. The chiller will automatically restart when the contacts close.

Device	Shutdown
CM-2 Module	Power fault
Solid State Starter	Power Fault
	Half Phase

“CONTROL PANEL – SCHEDULE”

The programmed Daily Schedule Setpoint has shutdown the chiller. If this occurs while the chiller is running, the Pre-rotation Vanes are driven fully closed prior to shutting down the chiller. The chiller will automatically restart at the next scheduled start time.

“STARTER – LOW SUPPLY LINE VOLTAGE”

(Mod “A” Solid State Starter)

The voltage in any phase of the AC Power Line Voltage supplying the Solid State Starter has decreased to the low line voltage threshold for 20 continuous seconds. The chiller will automatically restart when the voltage returns to the restart level. The thresholds are as follows:

Supply Voltage Range (Volts)	Shutdown (Volts)	Restart (Volts)
380	305	331
400	320	349
415	335	362
440-480	370	400
550-600	460	502
Supply Voltage Range disabled	none	N/A

“STARTER – HIGH SUPPLY LINE VOLTAGE”

(Mod “A” Solid State Starter)

The voltage in any phase of the AC Power Line Voltage supplying the Solid State Starter has increased to the high line voltage threshold for 20 continuous seconds. The chiller will automatically restart when the voltage returns to the restart level. The thresholds are as follows:

Supply Voltage Range (Volts)	Shutdown (Volts)	Restart (Volts)
380	415	414
400	436	435
415	454	453
440-480	524	523
550-600	655	654
Supply Voltage Range disabled	none	N/A

MOD “B” SOLID STATE STARTER CYCLING SHUTDOWN MESSAGES

“LCSSS INITIALIZATION FAILED”

When AC Power is restored to the system after a power failure, an initialization process occurs wherein the Control Center attempts to establish communications through the serial communications link with the Liquid Cooled Solid State Starter. If communications are not established within 10 consecutive attempts, a Cycling shutdown is performed and this message is displayed. The Control Center attempts to establish communications until successful.

“LCSSS - SERIAL COMMUNICATIONS”

After communications have been successfully established in the INITIALIZATION process, the Control Center initiates a data transmission to the Liquid Cooled Solid State Starter on the serial communications link every 2 seconds. After these communications have been established, if the Control Center does not receive a reply within 10 consecutive attempts, a Cycling shutdown is performed and this message is displayed. This same Cycling shutdown is performed, along with the same message, if the Liquid Cooled Solid State Starter does not receive a response from the control center after 10 consecutive attempts to communicate with the Control Center after INITIALIZATION has been successfully completed. The Control Center attempts to establish communications until successful.

“LCSSS SHUTDOWN - REQUESTING FAULT DATA...”

The Liquid Cooled State Starter Logic/Trigger Board has shut down the chiller but the Control Center has not yet received the cause of the fault from the LCSSS, via the serial communications link. The LCSSS shuts down the chiller by opening the Motor Controller LCSSS Stop Contacts (K1 relay located on the starter Logic/Trigger Board and connected between TB6-16 and TB6-53 in the Control Center). The Micro Board, in the Control Center then sends a request for the cause of the fault to the Logic/Trigger Board over the serial communications link. Since serial communications are initiated every 2 seconds, this message is typically displayed for a few seconds and then replaced with one of the following fault messages.

“LCSSS - STOP CONTACTS OPEN”

Refer to “LCSSS SHUTDOWN – REQUESTING FAULT DATA ...” above. If the Control Center’s Micro Board does not receive the cause of a starter initiated shutdown with 20 seconds of the shutdown, it is assumed

it is not forthcoming and that message is replaced with this message. The chiller can be started when the Motor Controller LCSSS Stop Contacts close.

A missing interlock jumper between Starter Logic/Trigger Board J1-1 and J1-12 will also produce this message.

“LCSSS - POWER FAULT”

The Liquid Cooled Solid State Starter Logic/Trigger Board has detected that the compressor motor current in one or more phases has decreased to <10% of the FLA for a minimum of 1 line cycle. This check is inhibited during the first 4 seconds of SYSTEM RUN and until the motor current is >25% of the FLA. The chiller will automatically restart upon completion of SYSTEM COASTDOWN.

“LCSSS - LOW PHASE (X) TEMPERATURE SENSOR”

The Liquid Cooled Solid State Starter Logic/Trigger Board has detected that the temperature of the starter phase A, B or C (designated as X in the message) Silicon Controlled Rectifier (SCR) Module has decreased to <37° F. This would generally be indicative of a disconnected or defective sensor. If all three SCR Modules are indicating a temperature of <37° F, the SCR Module cooling pump turns on. This is accomplished by disconnecting all three sensors. This feature allows Service Technicians to run the cooling pump while filling the cooling system by disconnecting plugs P2, P3 and P4 in the LCSSS.

“LCSSS - RUN SIGNAL”

The Liquid Cooled Solid State Starter receives two start signals from the Control Center simultaneously; one via the serial communications link and one via the start relay TB6-24 in the Control Center. If they are not received within 5 seconds of one another, a cycling shutdown is performed and this message is displayed. This is generally indicative of defective wiring.

“LCSSS - INVALID CURRENT SCALE SELECTION”

There is an invalid compressor motor current scale jumper combination installed in the Liquid Cooled Solid Starter Logic/Trigger Board J1. Jumper combination determines allowable “100% FLA” setpoint range; 7L-35 to 260A, 14L-65 to 510A, 26L-125 to 850A and 33L-215 to 1050A. The chiller will be permitted to start when the jumpers are configured correctly. Refer to YORK Starter service manual 160.00-O2 for valid jumper configurations.

“LCSSS - PHASE LOCKED LOOP”

The Liquid Cooled Solid State Starter Logic/Trigger Board phase locked loop circuit was not able to maintain lock with phase A of the power line. This could be caused by a power line anomaly such as sag or jitter. A power line frequency jitter of up to 3Hz/second can be tolerated. The chiller will automatically restart when lock has resumed.

“LCSSS - LOW SUPPLY LINE VOLTAGE”

The Liquid Cooled Solid State Starter Logic/Trigger Board has detected that the compressor motor AC power line voltage, in any phase, decreased below the low line voltage threshold continuously for 20 seconds. The chiller will automatically restart when the voltage in all phases returns to the restart level. The thresholds are as follows:

<u>Supply Voltage Range (Volts)</u>	<u>Shutdown (Volts)</u>	<u>Restart (Volts)</u>
Disabled	None	N/A
200-208	160	174
220-240	185	200
380	305	331
400	320	349
415	335	362
440-480	370	400
550-600	460	502

“LCSSS - HIGH SUPPLY LINE VOLTAGE”

The Liquid Cooled Solid State Starter Logic/Trigger Board has detected that the compressor motor AC power line voltage, in any phase, exceeded the high line voltage threshold continuously for 20 seconds. The chiller will automatically restart when the voltage in all phases returns to the restart level. The thresholds are as follows:

<u>Supply Voltage Range (Volts)</u>	<u>Shutdown(Volts)</u>	<u>Restart(Volts)</u>
Disabled	None	N/A
200-208	227	226
220-240	262	261
380	415	414
400	436	435
415	454	453
440-480	524	523
550-600	655	654

“LCSSS - LOGIC BOARD PROCESSOR”

Communication between the V25 Microprocessor and Digital Signal Processor (DSP) on the Liquid Cooled Solid State Starter Logic/Trigger Board has been interrupted. The chiller will automatically restart when communications are restored.

“LCSSS - LOGIC BOARD POWER SUPPLY”

Following application of power, this message is displayed and a snapshot of the LCSSS parameters and time of power failure are sent to the Control Center.

“LCSSS - PHASE LOSS”

The Liquid Cooled Solid State Starter Logic/Trigger Board has detected the line-to-line RMS voltage in any phase has decreased to $\leq 30\%$ of the lowest value of the programmed voltage range. If the programmed voltage range is “Disabled”, a value of 60 Vac is used as the threshold. The chiller will automatically restart when the line voltage is $>$ the shutdown threshold. The voltage range is programmed by a Service technician following instructions in Service Manual 160.80-M1.

SAFETY SHUTDOWN MESSAGES

“EVAPORATOR – LOW PRESSURE”

(This message is applicable only if the Smart Freeze feature is not activated. If Smart Freeze is activated and has initiated the shutdown, “Evaporator - Low Pressure - Smart Freeze” is displayed. Its description follows).

The evaporator pressure, as sensed by the Evaporator Transducer, has decreased to the Safety shutdown threshold. For water cooling applications, the safety shutdown threshold is a fixed value for the respective refrigerant. For Brine cooling applications, the safety shutdown threshold varies according to the concentration of the Brine solution. The Brine shutdown threshold is programmed at the YORK Factory. It should not be changed by anyone other than a qualified Service Technician following instructions in YORK Service Manual 160.80-M1. The chiller can be started after the evaporator pressure increases to the restart threshold and the COMPRESSOR switch is placed in the Stop-Reset (O) position.

		<u>Shutdown (PSIG)</u>	<u>Restart (PSIG)</u>
Water cooling -	R22	54.3	54.4
	R134a	25.0	25.1
Brine cooling -	R22	25.0 to 54.3 as programmed	+0.1 > Shutdown threshold
	R134a	6.0 to 25.0 as programmed	+0.1 > Shutdown threshold

“EVAPORATOR – LOW PRESSURE - SMART FREEZE”

Smart Freeze Protection is activated and has shut down the chiller because the evaporator temperature has been below the Smart Freeze threshold for greater than the

allowable number of seconds. If the evaporator refrigerant temperature sensor RT7 is Enabled (using procedure in Service Manual 160.80 M1), this parameter is used as the evaporator refrigerant temperature and the freeze threshold is 32.8°F. If RT7 is not Enabled, the evaporator refrigerant temperature used is the Evaporator Saturation Temperature, derived from the Evaporator Pressure Transducer and the freeze threshold is 34.0°F.

The count is incremented once for every second the evaporator refrigerant temperature is below the freeze threshold (but is never decremented below zero). The number of seconds it will take the chilled liquid to freeze is based on how far the evaporator refrigerant temperature is below the freeze threshold as follows:

Number of seconds to freezing = $(4053.7) / (\text{freeze threshold} - \text{evaporator refrigerant temperature})$

Smart Freeze is activated only if the feature has been Enabled by a Service Technician (following instructions in Service Manual 160.80-M1) and the Leaving Chilled Liquid Temperature setpoint is $< 38.0^\circ\text{F}$.

“EVAPORATOR – TRANSDUCER OR LEAVING LIQUID PROBE”

A possible defective Evaporator pressure Transducer or Leaving Chilled Liquid temperature Thermistor has been detected. The pressure and temperature that these devices are indicating are not in the correct relationship to each other. The Control Center converts the evaporator pressure to a Saturated Temperature value and compares this value to the Leaving Chilled Liquid temperature (difference = chilled liquid temp – evaporator saturated temp). The difference should not be outside the range of -2.5°F to $+25.0^\circ\text{F}$. If the Transducer and Thermistor are accurate, the Evaporator Saturated temperature should not be $> 2.5^\circ$ warmer nor $> 25.0^\circ\text{F}$ colder than the leaving chilled liquid temperature. In order to initiate a shutdown, the difference must be outside the acceptable range continuously for 10 minutes. The chiller can be started after the COMPRESSOR switch is placed in the Stop-Reset (O) position. This check is not performed when the optional Hot Gas feature is enabled in brine mode.

“EVAPORATOR – TRANSDUCER OR TEMPERATURE SENSOR”

A possible defective Evaporator pressure Transducer or Refrigerant Temperature Sensor has been detected. The Control Center converts the evaporator pressure to a Saturated Temperature value and compares this value to

the optional Evaporator Refrigerant Temperature Sensor. If the difference between these temperatures is greater than 3.0°F , continuously for 1 minute, this shutdown is performed.

This check is only performed under the following conditions:

- Chiller has been running for at least 10 minutes
- Evaporator Refrigerant temperature (RT7) has been enabled by a Service technician using instructions in YORK Service Manual 160.80.M1
- Not in Brine cooling mode
- Smart Freeze is enabled (Flash Memory Card version C.MLM.03.02.xxx, and later).
- Evaporator Temperature Sensor (RT7) or Evaporator Saturation Temperature is indicating a temperature of $< 32.0^\circ\text{F}$ (Flash Memory Card version C.MLM.03.02.xxx and later)

The chiller can be started after the temperatures are within 3.0°F of one another and the COMPRESSOR switch is placed in the Stop-reset (O) position.

“CONDENSER – HIGH PRESSURE CONTACTS OPEN”

The contacts of the electro-mechanical high pressure safety device, located on the condenser shell, have opened because this device has detected a pressure > 270.0 PSIG. The contacts will automatically close when the condenser pressure decreases to < 210.0 PSIG. The chiller can be started after the contacts close and the COMPRESSOR switch is placed in the Stop-Reset (O) position.

“CONDENSER – HIGH PRESSURE”

The condenser pressure, as sensed by the Condenser Transducer, has increased to > 270.0 PSIG. The chiller can be started after the pressure decreases to < 210.0 PSIG and the COMPRESSOR switch is placed in the Stop-reset (O) position.

“CONDENSER – HIGH PRESSURE – STOPPED”

(Software versions C.MLM.03.04.xxx and later or C.OPT.03.04.301 and later) The condenser pressure exceeded 245.0 PSIG while the chiller was stopped. High temperature condenser water flowing through the condenser while the chiller is shutdown can cause a condenser high pressure condition resulting in loss of refrigerant. This safety fault anticipates this problem by annunciating the condenser high pressure condition.

The chiller can be restarted after a Service Technician performs a special reset preset procedure contained in YORK Service Manual 160.80-M1.

“CONDENSER – PRESSURE TRANSDUCER OUT OF RANGE”

The Condenser Pressure Transducer is indicating a pressure that is >315.0 PSIG. This is outside the normal operating range of the transducer. This is generally indicates a defective transducer. The chiller can be started after the transducer is indicating a pressure that is within range and the COMPRESSOR switch is placed in the Stop-Reset (O) position.

“AUXILIARY SAFETY – CONTACTS CLOSED”

The Auxiliary Safety shutdown contacts, connected to I/O Board TB4-31 have closed, initiating a safety shutdown. This input is a general-purpose, user defined safety shutdown input. The chiller can be started after the contacts open and the COMPRESSOR switch is placed in the Stop-Reset (O) position.

“DISCHARGE – HIGH TEMPERATURE”

The discharge temperature, as sensed by the Discharge Temperature Thermistor, has increased to >212.0°F. The chiller can be started after the temperature decreases to <212.0°F and the COMPRESSOR switch is placed in the Stop-Reset (O) position.

“DISCHARGE – LOW TEMPERATURE”

The discharge temperature, as sensed by the Discharge Temperature Thermistor, has decreased to < 30.0° F. The chiller can be started after the temperature increases to > 30.0° F and the COMPRESSOR switch is placed in the Stop-Reset (O) position.

“OIL – HIGH TEMPERATURE”

The oil temperature, as sensed by the Oil Temperature Thermistor, has increased to > 170.0° F. The chiller can be started after the temperature decreases to < 170.0° F and the Compressor switch is placed in the Stop-Reset (O) position.

“OIL – LOW DIFFERENTIAL PRESSURE”

The differential oil pressure decreased to < 20.0 PSID for 2 continuous seconds after the chiller has been running for >3 minutes. The differential oil pressure is the difference between the oil pressure (as sensed at the input to the compressor) and the evaporator pressure. To restart the chiller, press the COMPRESSOR Switch to STOP/RESET position, then to START position.

“OIL - LOW DIFFERENTIAL SEAL PRESSURE”

The Seal Oil Differential Pressure decreased to < 20.0 PSID for 2 continuous seconds after the chiller has been running for > 3 minutes. To restart the chiller, press the COMPRESSOR Switch to STOP/RESET position, then to START position. This check is not performed if the chiller is not equipped with a Seal Oil Pressure Transducer and the feature has been Disabled by a Service Technician using instructions in YORK service Manual 160.80-M1.

“OIL OR CONDENSER TRANSDUCER ERROR”

The chiller is shut down because the oil pressure was greater than the (condenser pressure + 20 PSIG) for 10 continuous minutes after the chiller was running for 10 minutes. The condenser pressure in the formula is that which is measured at the condenser. The oil pressure is that which is measured at the input to the compressor. To restart the chiller, press COMPRESSOR switch to STOP/RESET position, then to START position.

“OIL - CLOGGED FILTER”

The chiller is shut down because the OIL FILTER DIFFERENTIAL PRESSURE (Refer to the description of the OIL SEPARATOR screen) exceeded 25 PSID for 8 continuous seconds. To restart the chiller, press COMPRESSOR switch to STOP/RESET position, then to START position.

“OIL - HIGH PRESSURE”

Chiller is shut down because the oil pressure transducer that is sensing oil pressure at the input to the compressor, indicated 300 PSIG while the chiller was running. The chiller will be allowed to restart when the pressure decreases to 299 PSIG. This safety shutdown is provided as a verification of transducer accuracy. Display of this message is generally indicative of a defective transducer or interface. To restart the chiller, press COMPRESSOR switch to STOP/RESET position, then to START position.

“OIL SEPARATOR - LOW LEVEL”

The chiller is shut down because the separator oil level switch has opened, indicating a low oil level in the separator. To restart the chiller, press COMPRESSOR switch to STOP/RESET position, then to START position.

The oil level switch must be open for 30 continuous seconds in order for this safety shutdown to be initiated. This prevents momentary switch fluctuations from causing nuisance shutdowns.

“CONTROL PANEL – POWER FAILURE”

A Control Power failure has occurred. The chiller can be started after the COMPRESSOR switch is placed in the Stop-reset (O) position. This message can indicate a Cycling (auto-restart after power failure) or Safety (manual restart after power failure) shutdown, depending upon Control Center configuration. It indicates a Cycling shutdown when displayed in orange characters; Safety shutdown when displayed in red characters. The Control center is configured for auto-restart or manual restart after power failure by a qualified Service technician following instructions in YORK Service Manual 160.80-M1.

“MOTOR OR STARTER – CURRENT IMBALANCE”

The three phase compressor motor current imbalance was > 30% continuously for 45 seconds. The imbalance is not checked until the chiller has been running for at least 45 seconds and the average of the three phases of motor current is > 80% of the programmed 100% chiller Full Load Amps. The average is calculated as: $I_{ave} = (I_a + I_b + I_c) / 3$. The imbalance is calculated as:

$$\frac{(I_a - I_{ave}) + (I_b - I_{ave}) + (I_c - I_{ave})}{2(I_{ave})} \times 100$$

The Style B Solid State Starter detects the unbalance condition and advise the Optiview Control Center Microboard via serial communications. The Style A Solid State Starter returns the 3-phase motor current values to the Optiview Control Center Microboard where the unbalance calculation is performed. This safety shutdown is not performed on Electro- mechanical starter applications.

“WATCHDOG – SOFTWARE REBOOT”

The Micro Board’s software Watchdog initiated a Microprocessor reset because it detected that a portion of the chiller operating Program was not being executed. The result of this reset is a Safety shutdown and re-initialization of the Program. This is generally indicative of a severe electrical power disturbance or impending Micro Board Failure. The chiller can be started after the COMPRESSOR switch is placed in the Stop-Reset (O) position.

MOD “B” SOLIDSTATE STARTER SAFETY SHUTDOWN MESSAGES**“LCSSS SHUTDOWN - REQUESTING FAULT DATA...”**

The Liquid Cooled Solid State Starter Logic/Trigger Board has shut down the chiller but the Control Center has not yet received the cause of the fault from the LCSSS, via the serial communications link. The LCSSS shuts down the chiller by opening the Motor Controller LCSSS Stop Contacts (K1 relay located on the Logic/Trigger Board and connected between TB6-16 and TB6-53 in the Control Center). The Micro Board, in the Control Center, then sends a request for the cause of the fault to the Logic/Trigger Board over the serial communications link. Since serial communications are initiated every 2 seconds, this message is typically displayed for a few seconds and then replaced with one of the following fault messages.

“LCSSS - HIGH INSTANTANEOUS CURRENT”

The Liquid Cooled Solid State Starter Logic/Trigger Board detected that the compressor motor current in any phase exceeded 1.1(1.414 x RMS value of the programmed Start Current) for a minimum of 1 second. The chiller can be started after the COMPRESSOR switch is placed in the Stop-Reset (O) position.

“LCSSS - HIGH PHASE (X) HEATSINK TEMPERATURE - RUNNING”

The Liquid Cooled Solid State Starter Logic/Trigger Board has detected the temperature of phase A, B or C (designed as X in the message) Silicon Controlled Rectifier (SCR) Modules has exceeded 212° F while the chiller was running. The safety can be reset after all SCR temperatures are < 210° F and the COMPRESSOR switch is placed in the Stop-Reset position (O). However, the chiller cannot be started until all SCR temperatures are < 109° F. During the shutdown, the starter cooling pump runs until the temperature is < 109° F.

“LCSSS - 105% MOTOR CURRENT OVERLOAD”

The highest phase of the compressor motor current increased to > 105% of the programmed 100% chiller Full Load Amps continuously for 40 seconds. The chiller can be started after the COMPRESSOR switch is placed in the Stop-Reset (O) position.

“LCSSS - PHASE (X) SHORTED SCR”

A shorted Silicon Controlled Rectifier (SCR) in phase A, B or C (designated as X in the message) has been detected by the Liquid Cooled Solid State Starter Logic/Trigger Board. The voltage across each SCR is monitored to detect the shorted condition. The shorted condition must exist continuously for 5 seconds in order to announce the fault. This check is disabled while the chiller is running. The chiller can be started after the condition has been corrected and the COMPRESSOR switch is placed in the Stop-Reset (O) position.

“LCSSS - OPEN SCR”

An open Silicon Controlled Rectifier (SCR) has been detected by the Liquid Cooled Solid State Starter Logic/Trigger Board. The open condition must exist continuously for 5 seconds in order to announce the fault. The chiller can be started after the condition has been corrected and the COMPRESSOR switch is placed in the Stop-Reset (O) position. This check is disabled when the chiller is shut down. In certain applications, local power line conditions could interfere with the open SCR detection technique. This requires a qualified Service Technician to disable this check. Refer to YORK Service Manual 160.80-M1.

“LCSSS – PHASE (X) OPEN SCR”

(Software versions C.MLM.03.04.xxx and later or C.OPT.03.04.301 and later) An open SCR in phase A, B or C (designated as X in message) has been detected. This safety shutdown has the same criteria as “LCSSS – OPEN SCR” above. However, when the Solid State Starter Logic/Trigger Board is equipped with Eprom version C.SSS.01.03 (and later) and the Optiview Control Center is equipped with above software, the phase in which the open SCR occurred is identified.

“LCSSS - PHASE ROTATION”

The Liquid Cooled Solid State Starter Logic/Trigger Board has detected the three phase compressor motor power line voltage phase rotation is not correct. The chiller can be started after the phase rotation is correct and the COMPRESSOR Switch is placed in the Stop-Reset (O) position.

SECTION 3 PRINTERS



23887A

OKIDATA MICROLINE 184



23889A

WEIGH-TRONIX



00085VIP

SEIKO DPU-414

FIG. 34 – PRINTERS

PRINTERS

A printer can be connected to the Control Center's Micro Board to print the following reports. The screen from which each report can be generated is listed in parenthesis.

- **Status** - Present system parameters (Printer, Home)
- **Setpoints** - Present programmed values of all setpoints (Printer, Setpoints)
- **Schedule** - Present value of programmed daily schedule (Printer, Schedule)
- **Sales Order** - Information on Sales Order Screen (Printer, Sales Order)
- **History** - System parameters at the time of the last normal stop, last fault while running and last 10 faults, whether running or not (Printer, History)
- **Cycling or Safety shutdown initiated Print** - Snapshot of all system parameters at instant of shutdown. Automatically occurs if printer is connected at time of shutdown.
- **Trend** (Flash Memory card version C.MLM.03.02.xxx and later) - Prints a snapshot of the existing trend screen data or prints new data collected after the trend print key is pressed.

The printer can be permanently connected to the Control Center or connected as required to produce a report. If permanently connected, a **DATA LOGGING** feature can produce a Status report automatically, beginning at an Operator selected start time and occurring at an Operator selected interval thereafter.

The following figures are examples of the different print reports. Solid State Starter application print reports shown. Electro-mechanical starter and Variable Speed Drive reports are similar but print parameters applicable to those devices.

- Figure 35 - Status
- Figure 36 - Setpoints
- Figure 37 - Schedule
- Figure 38 - Sales Order
- Figure 39 - History
- Figure 40 - Security Log (Flash Memory Card version C.MLM.03.03.xxx and later)
- Figure 41 - Trend (Flash Memory Card version C.MLM.03.02.xxx and later)
- Figure 42 - Custom Screen

PRINTERS

The following Printers can be used. **Printers must be equipped with an RS-232 Serial interface.**

- **Okidata** –
Models: 182,182 turbo, 184 turbo
Dimensions: 14 in. wide x 10.5 in. deep
Paper: 8.5 in. wide
Type: Dot matrix impact
Purchase: 800-OKIDATA
- **Weigh-Tronix** –
Models: 2600, 1220
Dimensions: 2.3 in. wide x 2.8 in. deep
Paper: 2.25 in. wide
Type: Dot matrix impact
Purchase: USA 800-982-6622
International 707-527-5555
- **Seiko** –
Model: DPU414-30B (Power supply PW4007-U I required)
Dimensions: 6.3 in. wide x 6.7 in. deep
Paper: 4.4 in. wide
Type: Thermal
Purchase: Reptron Electronics, Inc
Phone: 800-800-5441 ext. 4686
Fax: 813-891-4056
Attn: Nancy Arthur, Account Manager
(narthur@reptron.com)

The Control Center provides the required formatting control codes for the printers above when the printer is selected on the PRINTER Screen in the instructions below. These codes are transmitted through the serial interface to the printer to provide a proper print format. Different printers require different formatting control codes. Other printers might provide proper operation when connected to the Control Center. However, the print format may not be correct or as desired. Proceed with caution and use the following guidelines if an unlisted printer is selected:

1. All must be capable of RS-232 Serial communications.
2. Primary differences between printers involve the formatting control codes required by the printer. These codes are sent from the Control Center to the printer.

For example, Weigh-Tronix printers require a control code to select 40 column width. This same code is interpreted by the Okidata printer as an instruction to print wide characters. In some instances, a printer will ignore a code it cannot interpret.

- The Control Center requires a busy signal from the printer when the printer receive buffer is full. This causes the Control Center to momentarily terminate data transmission until the printer can accept more data. The busy signal polarity must be asserted low when busy.

PRINTER CONNECTIONS

Connect the printers to the Control Center Micro Board as follows. Only one printer can be connected at a time.

• OKIDATA 182, 182 turbo, 184 turbo

Micro Board	Printer	Function
J2-4	pin 3	Tx (data to printer)
J2-2	pin 11	DSR (busy signal from printer)
J2-9	pin 7	Gnd
Cabinet		shield

• WEIGH-TRONIX

Micro Board	Printer	Function
J2-4	pin 2	Tx (data to printer)
J2-2	pin 5	DSR (busy signal from printer)
J2-9	pin 7	Gnd
Cabinet		shield

• SEIKO

Micro Board	Printer	Function
J2-4	pin 3	Tx (data to printer)
J2-2	pin 8	DSR (busy signal from printer)
J2-9	pin 5	Gnd
Cabinet		shield

Hardware required:

Cable – #18 AWG stranded 50ft. maximum length.

Connectors –

- Micro Board: None. Strip 1/4" insulation from wire and insert into screw terminal block.
- Printers: Okidata - 25 pin plug DB-25P or equivalent; Shell DB-C2-J9 or equivalent. Weigh-Tronix - Same as Okidata. Cable assembly available from Weigh-Tronix. Seiko - 9-Pin D-type Subminiature (DB-9 pin male).

PRINTER SETUP

The selected printer must be configured as follows. Refer to manual provided by Printer manufacturer with respective Printer.

• OKIDATA 182, 182 turbo, 184 turbo Printer

CONTROL BOARD Switch settings:

- SW1 - on Unslashed 0
- 2 - off Unslashed 0
- 3 - off Unslashed 0
- 4 - off Form Length 11 in.
- 5 - on Form Length 11 in.
- 6 - off Auto Line Feed off
- 7 - on 8 bit data
- 8 - off Enable front panel

If equipped with a SUPER SPEED serial Board:

- SW1-1 - on Odd or even parity
- 1-2 - on No parity
- 1-3 - on 8 bit data
- 1-4 - on Protocol ready/busy
- 1-5 - on Test select
- 1-6 - on Print mode
- 1-7 - off SDD(-) pin 11
- 1-8 - on SDD(-) pin 11
- 2-1 - on 1200 Baud*
- 2-2 - on 1200 Baud*
- 2-3 - off 1200 Baud*
- 2-4 - off DSR active
- 2-5 - on Buffer threshold 32 bytes
- 2-6 - on Busy signal 200ms
- 2-7 - on DTR space after power on
- 2-8 - not used

If equipped with HIGH SPEED serial board:

- SW1 - off (-) Low when busy
- 2 - off 1200 Baud*
- 3 - off 1200 Baud*
- 4 - on 1200 Baud*
- 5 - not used
- 6 - off no parity
- 7 - off Pin 20 & pin 11 act as busy line

• WEIGH-TRONIX Printer

- IMP-24 Model 2600

- SW1 - off 1200 Baud*
- 2 - on 1200 Baud*

Model 1220**- Configure Menu**

Baud= 1200
 Data Bits = 8
 Stop Bits = 1
 Hshake = Busy-Line
 Cols = 32
 Invert = No
 Font = 5 x 8
 Mag = None

- Custom Menu

Auto Seq = No
 Zero = 0
 Pound sign = #
 _(Underscore)
 Busy invert = no
 Online/offline = yes
 Ext Ch Set = no
 Print ready = yes

Set Clock = not used

Reset Seq = not used

• SEIKO

DipSW 1-1 = off Input-Serial
 1-2 = on Printing speed high
 1-3 = on Auto loading - on
 1-4 = off Auto LF - off
 1-5 = on Setting Command - Enable
 1-6 = off Printing density - 100%
 1-7 = on Printing density - 100%
 1-8 = on Printing, density - 100%

DipSW 2-1 = on Printing Columns - 40
 2-2 = on User Font Back-up - on
 2-3 = on Character Select - normal
 2-4 = off Zero - slash
 2-5 = on International character set - American
 2-6 = on International character set - American
 2-7 = on International character set - American
 2-8 = off International character set - American

DipSW 3-1 = on Data length - 8 bits
 3-2 = on Parity Setting - no
 3-3 = on Parity condition - odd
 3-4 = on Busy control - H/W busy
 3-5 = on Baud rate select - 1200*
 3-6 = off Baud rate select - 1200*

3-7 = on Baud rate select - 1200*

3-8 = off Baud rate select - 1200*

* Settings shown for 1200 Baud. Other Baud rates can be selected. Refer to Printer manufacturer's manual supplied with Printer.

CONTROL CENTER SETUP**Chiller ID**

Access Level Required: OPERATOR or Higher
 Using the COMMS Screen, assign an Identification number to the chiller. This number will appear at the top of each report.

Printer Setup

Access Level Required: OPERATOR or Higher
 Using the COMMS Screen, the Control Center must be configured to transmit data in the same format as the Printer is configured to receive the data. The following values must be entered.

- Baud Rate - Set as desired. Value selected must be the same as Printer configuration above.
- Data Bits - 8
- Parity - None
- Stop Bits - 1

Printer Type

Access Level required: OPERATOR or Higher
 Using the PRINTER Screen, the actual Printer type connected to the Control Center must be entered. Selection determines the control codes that are sent to the Printer. These codes determine such things as lines per inch, character width and general formatting. Available selections are: Okidata, Weigh-Tronix and Seiko.

Automatic Data Logging

Access Level required: OPERATOR or Higher.
 If automatic data logging is desired, a Status Report can be automatically printed at a specified interval beginning at a specified time, using the PRINTER Screen. The interval is programmable over the range of 1 minute to 1440 minutes in 1 minute increments. The first print will occur at the programmed START time and occur at the programmed OUTPUT INTERVAL thereafter. The time remaining until the next print is displayed on the PRINTER Screen.

- Automatic Printer Logging - Enables and disables automatic data logging
- Log Start Time - Enter the time the first print is desired.
- Output Interval - Enter the desired interval between prints.

**YORK UPDATE
Chiller ID 0**

(c) 1997 - 2001 YORK INTERNATIONAL CORPORATION
Mon 21 Jun 1999 1:26:51 PM

SYSTEM RUN
LEAVING CHILLED LIQUID CONTROL
[List all warnings presently active]

Controls C.MLM.03.03.102
Run Time 0 Days 2 Hr 59 Min
Operating Hours = 298 Hr
Number Of Starts = 106
Control Source = Local

Evaporator

Leaving Chilled Active Setpoint = 45.0°F
Chilled Liquid Pump = Run
Chilled Liquid Flow Switch = Closed
Leaving Chilled Liquid Temp = 50.0°F
Return Chilled Liquid Temp = 59.3°F
Evaporator Pressure = 78.2 Psig
Evaporator Saturation Temperature = 41.1°F
Evaporator Refrigerant Temperature = 40.0°F
[If Refrigerant Sensor enabled]
Small Temperature Difference = 10.0°F

Condenser

Condenser Liquid Pump = Run
Condenser Liquid Flow Switch = Closed
Leaving Condenser Liquid Temperature = 85.0°F
Return Condenser Liquid Temperature = 94.9°F
Condenser Pressure = 135.8 Psig
Condenser Saturation Temperature = 71.7°F
Small Temperature Difference = -13.3°F
Drop Leg Refrigerant Temperature = 85.0°F
[If Drop Leg Sensor enabled]
Sub Cooling Temperature = 2.0°F
[If Drop Leg Sensor enabled]

Compressor

Discharge Temperature = 121.6°F
Slide Valve Position = 28 %

Oil Sump

Oil Pressure = 120.7 Psig
Differential Oil Pressure = 41.6 Psid
Filter Pressure = 118.9 Psig
Differential Filter Pressure = 13.1 Psid
Seal Pressure = 105.2 Psig
[If Seal Pressure Sensor Enabled]
Seal Differential Pressure = 32.8 Psid
[If Seal Pressure Sensor Enabled]
Oil Temperature = 137.9°F
Oil Return Solenoid = On

Variable Orifice Control

Delta P = 57.6 Psid
Variable Orifice = Closed

Hot Gas

Hot Gas Solenoid = Off

[Skip the following section if Motor Type is not EM]
Electro-Mechanical Starter

Motor Run = On
% Full Load Amps = 94 %

[Skip the following section if Motor Type is not Mod A
SSS]

Liquid-Cooled Solid State Starter

Motor Run = On
% Full Load Amps = 94 %
Phase A Voltage = 447 V
Phase B Voltage = 409 V
Phase C Voltage = 442 V
Phase A Current = 193 A
Phase B Current = 204 A
Phase C Current = 190 A

[Skip the following section if Motor Type is not Mod B
SSS]

Liquid-Cooled Solid State Starter

Motor Run = On
% Full Load Amps = 94 %
Starter Model = 33L
KW Hours = 20723 KWH
Input Power = 145 KW
Phase A Voltage = 447 V
Phase B Voltage = 409 V
Phase C Voltage = 442 V
Phase A Current = 193 A
Phase B Current = 204 A
Phase C Current = 190 A
Phase A Temperature = 88°F
Phase B Temperature = 89°F
Phase C Temperature = 75°F

FIG. 35 – SAMPLE PRINTOUT (STATUS REPORT)

```

YORK SETPOINTS
CHILLER ID 0
(c) 1997 - 2001 YORK INTERNATIONAL CORPORATION
Mon 21 Jun 1999 1:27:39 PM

Software Versions
-----
---
Controls =
C.MLM.03.03.102
BIOS = C.MLM.00.03
Kernel = 0.18
GUI = 0.25
SIO = 0.21
GPIC = 0.03
SSS [Skip if Motor Type is not Serial SSS] =
C.SSS.01.01

System Information
-----
---
System Language = English
Data Display Mode = English
Control Source = Local
Remote Analog Input Range = 0 - 10 Volts
Clock = Enabled

Jumper Settings
-----
---
Chilled Liquid Pump Operation = Standard
Refrigerant Selection = R22
Anti-Recycle = Enabled
Power Failure Restart = Auto
Liquid Type = Water

Printer Setup
-----
---
Automatic Printer Logging = Disabled
Log Start Time = 12:00 am
Output Interval = 60 Min
Printer Type = Okidata
Baud = 9600 Baud
Data Bits = 8 Bits
Parity = None
Stop Bits = 1 Bit

COM 2 Setup
-----
---
Baud = 19200 Baud
Data Bits = 8 Bits
Parity = Odd
Stop Bits = 1 Bit

Evaporator
-----
---
Leaving Chilled Local Setpoint = 45.0°F
Leaving Chilled ISN Setpoint = 45.0°F
Leaving Chilled Modem Setpoint = 45.0°F
Leaving Chilled Analog Setpoint = 45.0°F
Leaving Chilled Digital Setpoint = 45.0°F
Remote Range = 10.0°F
Sensitivity = Normal
Restart Offset = 0.0 °F
    
```

```

Restart Setpoint = 45.0°F
Shutdown Offset = 4.0°F
Shutdown Setpoint = 41.0 ~F
Brine Low Evaporator Cutout = 25.0 Psig
Smart Freeze = Off
Refrigerant = Disabled

Condenser
-----
High Pressure Warning Threshold = 44.9 Psig
Drop Leg = Disabled

Compressor
-----
Maximum Load Temperature = 70.0 ~F
Maximum Load FLA = 60 %
Minimum Load Control Source = Slide Valve
Motor FLA Limit = 15 %
Freeze Warning = Enable
Freeze Time = 30 Min
Ice Storage = Off

Oil Sump
-----
Auto Zero = Enable
Seal Pressure = Enable
Oil Recovery = Enable

Variable Orifice Control
-----
Delta P Setpoint = 25 Psid

Hot Gas
-----
Hot Gas = Disabled
On Setpoint = 1.0 ~F
Off Setpoint = 2.0 ~F

[Skip the following section if Motor Type is not EM]
Electro-Mechanical Starter
-----
Local Motor Current Limit = 100 %
Remote ISN Current Limit = 100 %
Remote Analog Current Limit = 100 %
Remote Digital Current Limit = 100 %
Remote Modem Current Limit = 100 %
Pulldown Demand Limit = 100 %
Pulldown Demand Time = 0 Min

[Skip the following section if Motor Type is not Mod A
SSS]
Liquid-Cooled Solid State Starter
-----
Local Motor Current Limit = 100 %
Remote ISN Current Limit = 100 %
Remote Analog Current Limit = 100 %
Remote Digital Current Limit = 100 %
Remote Modem Current Limit = 100 %
Pulldown Demand Limit = 100 %
Pulldown Demand Time = 0 Min
Scale/Model = 600 V, 281 A
Supply Voltage Range = Disabled
Full Load Amps = 150 A
Current Imbalance Check = Disabled
    
```

3

FIG. 36 – SAMPLE PRINTOUT (SETPOINT REPORT)

```

[Skip the following section if Motor Type is not Mod B
SSS]
Liquid-Cooled Solid State Starter
-----
---
Local Motor Current Limit           = 100 %
Remote ISN Current Limit             = 100 %
Remote Analog Current Limit          = 100 %
Remote Digital Current Limit         = 100 %
Remote Modem Current Limit           = 100 %
Pull-down Demand Limit               = 100 %
Pull-down Demand Time                = 0 Min
Starter Model                        = 33L
Voltage Range                        = Disabled
Full Load Amps                      = 215 A
Starting Current                     = 1460 A
Open SCR                             = Disabled

```

FIG. 36 – CONTINUED

```

YORK SCHEDULE
CHILLER ID      3
© 1997 - 1999 YORK INTERNATIONAL CORPORATION
MON 29 MAR 1999      1 27 PM

SCHEDULE = OFF

STANDARD SCHEDULE
-----
---
SUN  START = OFF      STOP = OFF
MON  START = 06:00 AM STOP = 05:00 PM
TUE  START = 06:00 AM STOP = 05:00 PM
WED  START = 06:00 AM STOP = 05:00 PM
THU  START = 06:00 AM STOP = 05:00 PM
FRI  START = 06:00 AM STOP = 05:00 PM
SAT  START = OFF      STOP = OFF

EXCEPTION DAYS
-----
---
15 JUL 1999 START = OFF      STOP = OFF
16 JUL 1999 START = 08:00 AM STOP = 10:00 PM

```

FIG. 37 – SAMPLE PRINTOUT (SCHEDULE)

YORK SALES ORDER
CHILLER ID 3
 © 1997 - 1999 YORK INTERNATIONAL CORPORATION
 MON 29 MAR 1999 1 28 PM

ORDER INFORMATION

 COMMISSIONING DATE 01 OCT 1999
 JOB NAME
 JOB LOCATION
 MODEL NUMBER YSFBFAS3-CVE
 YORK ORDER NUMBER 99102014-01
 PANEL SERIAL NUMBER 12345678
 CHILLER SERIAL NUMBER 12345678

DESIGN LOAD - EVAPORATOR

 PASSES 2
 DESIGN WORKING PRESSURE 150
 FOULING FACTOR 0.00010
 PRESSURE DROP 21.1
 NOZZLE ARRANGEMENT IN 2
 NOZZLE ARRANGEMENT OUT 3
 LEAVING TEMPERATURE 44.0
 RETURN TEMPERATURE 56.0
 GPM 1500.0
 TUBES 181

DESIGN LOAD - CONDENSER

 PASSES 2
 DESIGN WORKING PRESSURE 150
 FOULING FACTOR 0.00025
 PRESSURE DROP 28.0
 NOZZLE ARRANGEMENT IN 1
 NOZZLE ARRANGEMENT OUT
 LEAVING TEMPERATURE 94.3
 RETURN TEMPERATURE 85.0
 GPM 2250.0
 TUBES 230

NAMEPLATE INFORMATION

 MOTOR CODE CV
 POWER (VOLTS) 460
 PHASES 3
 FREQUENCY (HZ) 60
 LOCKED ROTOR AMPS 4400
 FULL LOAD AMPS 642
 INRUSH AMPS 655

SYSTEM INFORMATION

 REFRIGERANT R134A
 TONS 150
 GEAR CODE RK
 LIQUID TYPE WATER
 BRINE PERCENT
 KILOWATTS INPUT 467
 VSD / SSS / EM SSS

3

FIG. 38 – SAMPLE PRINTOUT (SALES ORDER)

```

YORK History 1
Chiller ID 0
(c) 1997 - 2001 YORK INTERNATIONAL CORPORATION
Mon 21 Jun 1999 1:26:51 PM

SYSTEM READY TO START
LCSSS - LOGIC BOARD POWER SUPPLY
[List any warnings that were active at the time of
shutdown]

Controls      C.MLM.03.03.102
Run Time      0 Days      2 Hr      59 Min
Operating Hours              = 298 Hr
Number Of Starts              = 106
Control Source                = Local

Evaporator
-----
Leaving Chilled Active Setpoint      = 45.0 °F
Chilled Liquid Pump                  = Run
Chilled Liquid Flow Switch           = Closed
Leaving Chilled Liquid Temperature   = 50.0 °F
Return Chilled Liquid Temperature    = 59.3 °F
Evaporator Pressure                  = 78.2 Psig
Evaporator Saturation Temperature    = 41.1 °F
Evaporator Refrigerant Temperature  = 40.0 °F
      [If Refrigerant Sensor enabled]
Small Temperature Difference          = 10.0 °F

Condenser
-----
Condenser Liquid Pump                = Run
Condenser Liquid Flow Switch         = Closed
Leaving Condenser Liquid Temperature = 85.0 °F
Return Condenser Liquid Temperature  = 94.9 °F
Condenser Pressure                   = 135.8 Psig
Condenser Saturation Temperature     = 71.7 °F
Small Temperature Difference          = -13.3 °F
Drop Leg Refrigerant Temperature     = 85.0 °F
      [If Drop Leg Sensor enabled]
Sub Cooling Temperature              = 2.0 °F
      [If Drop Leg Sensor enabled]

Compressor
-----
Discharge Temperature                = 121.6 °F
Slide Valve Position                 = 28 %

Oil Sump
-----
Oil Pressure                         = 120.7 Psig
Differential Oil Pressure             = 41.6 Psid
Filter Pressure                      = 118.9 Psig
Differential Filter Pressure          = 13.1 Psid
Seal Pressure                        = 105.2 Psig
      [If Seal Pressure Sensor Enabled]
Seal Differential Pressure            = 32.8 Psid
      [If Seal Pressure Sensor Enabled]
Oil Temperature                      = 137.9 °F
Oil Return Solenoid                  = On
    
```

```

Variable Orifice Control
-----
Delta P                              = 57.6 Psid
Variable Orifice                      = Closed

Hot Gas
-----
Hot Gas Solenoid                     = Off

[Skip the following section if Motor Type is not EM]
Electro-Mechanical Starter
-----
Motor Run                             = On
% Full Load Amps                     = 94 %

[Skip the following section if Motor Type is not Mod A
SSS]
Liquid-Cooled Solid State Starter
-----
Motor Run                             = On
% Full Load Amps                     = 94 %
Phase A Voltage                       = 447 V
Phase B Voltage                       = 409 V
Phase C Voltage                       = 442 V
Phase A Current                       = 193 A
Phase B Current                       = 204 A
Phase C Current                       = 190 A

[Skip the following section if Motor Type is not Mod B
SSS]
Liquid-Cooled Solid State Starter
-----
Motor Run                             = On
% Full Load Amps                     = 94 %
Starter Model                         = 33L
KW Hours                              = 20723 KWH
Input Power                           = 145 KW
Phase A Voltage                       = 447 V
Phase B Voltage                       = 409 V
Phase C Voltage                       = 442 V
Phase A Current                       = 193 A
Phase B Current                       = 204 A
Phase C Current                       = 190 A
Phase A Temperature                   = 88 °F
Phase B Temperature                   = 89 °F
Phase C Temperature                   = 75 °F
    
```

FIG. 39 – SAMPLE PRINTOUT (HISTORY)

YORK Setpoint Change Log**Chiller ID 0**

(c) 1997 - 2001 YORK INTERNATIONAL CORPORATION

Fri 05 Oct 2001 4:48:04 PM

Log Entry 1 Evaporator - Leaving Chilled Local Setpoint

```

---
Date                = 05 Oct 2001
Time                = 4:23:49 PM
Access Level        = Service
User Id             = 4268
Old Value           = 46.5 ~F
New Value           = 48.0 ~F

```

Log Entry 2 Condenser - High Pressure Warning Threshold

```

---
Date                = 05 Oct 2001
Time                = 1:36:12 PM
Access Level        = Service
User Id             = 4268
Old Value           = 162.5 Psig
New Value           = 225.0 Psig

```

Log Entry 3 Condenser - Drop Leg

```

---
Date                = 05 Oct 2001
Time                = 1:36:02 PM
Access Level        = Service
User Id             = 4268
Old Value           = Disabled
New Value           = Enabled

```

Log Entry 4 Evaporator - Refrigerant

```

---
Date                = 05 Oct 2001
Time                = 1:35:48 PM
Access Level        = Service
User Id             = 4268
Old Value           = Disabled
New Value           = Enabled

```

3

FIG. 40 – SAMPLE PRINTOUT (SECURITY LOG REPORT)

```

YORK Trend
Chiller ID 163
© 1997 - 2000 YORK INTERNATIONAL CORPORATION
MON 09 OCT 2000 3:33:47 PM

DATA 1: LEAVING CHILLED LIQUID TEMPERATURE
DATA 2: RETURN CHILLED LIQUID TEMPERATURE
DATA 3: EVAPORATOR PRESSURE
DATA 4: LEAVING CONDENSER LIQUID TEMPERATURE
DATA 5: RETURN CONDENSER LIQUID TEMPERATURE
DATA 6: CONDENSER PRESSURE

  TIME    DATA 1  DATA 2  DATA 3  DATA 4  DATA 5  DATA 6
3:33:47PM 45.5°F  55.0°F  39.0 PSIG 95.0°F  85.0°F 120.0 PSIG
3:33:48PM 45.5°F  55.0°F  39.0 PSIG 95.0°F  85.0°F 120.0 PSIG
3:33:49PM 45.5°F  55.0°F  39.0 PSIG 95.0°F  85.0°F 120.0 PSIG
3:33:50PM 45.5°F  55.0°F  39.0 PSIG 95.0°F  85.3°F 120.1 PSIG
3:33:51PM 45.5°F  55.2°F  39.1 PSIG 95.1°F  85.4°F 120.2 PSIG
    
```

FIG. 41 – SAMPLE PRINTOUT (TREND DATA NEW OR EXISTING POINTS)

```

YORK Custom View
Chiller ID 0
(c) 1997 - 2001 YORK INTERNATIONAL CORPORATION
Mon 21 Jun 1999 1:28:25 PM

Leaving Chilled Liquid Temperature      = 45.0 °F
Return Chilled Liquid Temperature       = 55.0 °F
Leaving Condenser Liquid Temperature    = 95.0 °F
Return Condenser Liquid Temperature     = 85.0 °F
Evaporator Saturation Temperature       = 41.0 °F
Condenser Saturation Temperature        = 78.5 °F
Evaporator Pressure                     = 70.0 Psig
Condenser Pressure                      = 140.0 Psig
Oil Pressure                             = 45.0 Psid
% Full Load Amps                        = 50 %
    
```

FIG. 42 – SAMPLE PRINTOUT (CUSTOM SCREEN REPORT)

SI METRIC CONVERSION

The following factors can be used to convert from English to the most common SI Metric values.

MEASUREMENT	MULTIPLY THIS ENGLISH VALUE	BY	TO OBTAIN THIS METRIC VALUE
CAPACITY	TONS REFRIGERANT EFFECT (ton)	3.516	KILOWATTS (kW)
POWER	KILOWATTS (kW)	NO CHANGE	KILOWATTS (kW)
	HORSEPOWER (hp)	0.7457	KILOWATTS (kW)
FLOW RATE	GALLONS / MINUTE (gpm)	0.0631	LITERS / SECOND (L/s)
LENGTH	FEET (ft)	304.8	MILLIMETERS (mm)
	INCHES (in)	25.4	MILLIMETERS (mm)
WEIGHT	POUNDS (lb)	0.4536	KILOGRAMS (kg)
VELOCITY	FEET / SECOND (fps)	0.3048	METERS / SECOND (m/s)
PRESSURE DROP	FEET OF WATER (ft)	2.989	KILOPASCALS (k Pa)
	POUNDS / SQ. INCH (psi)	6.895	KILOPASCALS (k Pa)

TEMPERATURE:

To convert degrees Fahrenheit (°F) to degrees Celsius (°C) subtract 32° and multiply by 5/9 or 0.5556.

To convert a temperature range (i.e., 10°F or 12°F chilled water range) from Fahrenheit to Celsius, multiply by 5/9 or 0.5556.

