



**MILLENNIUM™
ROTARY SCREW LIQUID CHILLERS**

INSTALLATION, OPERATION & MAINTENANCE

Supersedes: Nothing

Form 160.80-NOM1 (1199)

**MODELS
YS BA BA S0 THROUGH YS FC FB S5
STYLE E**

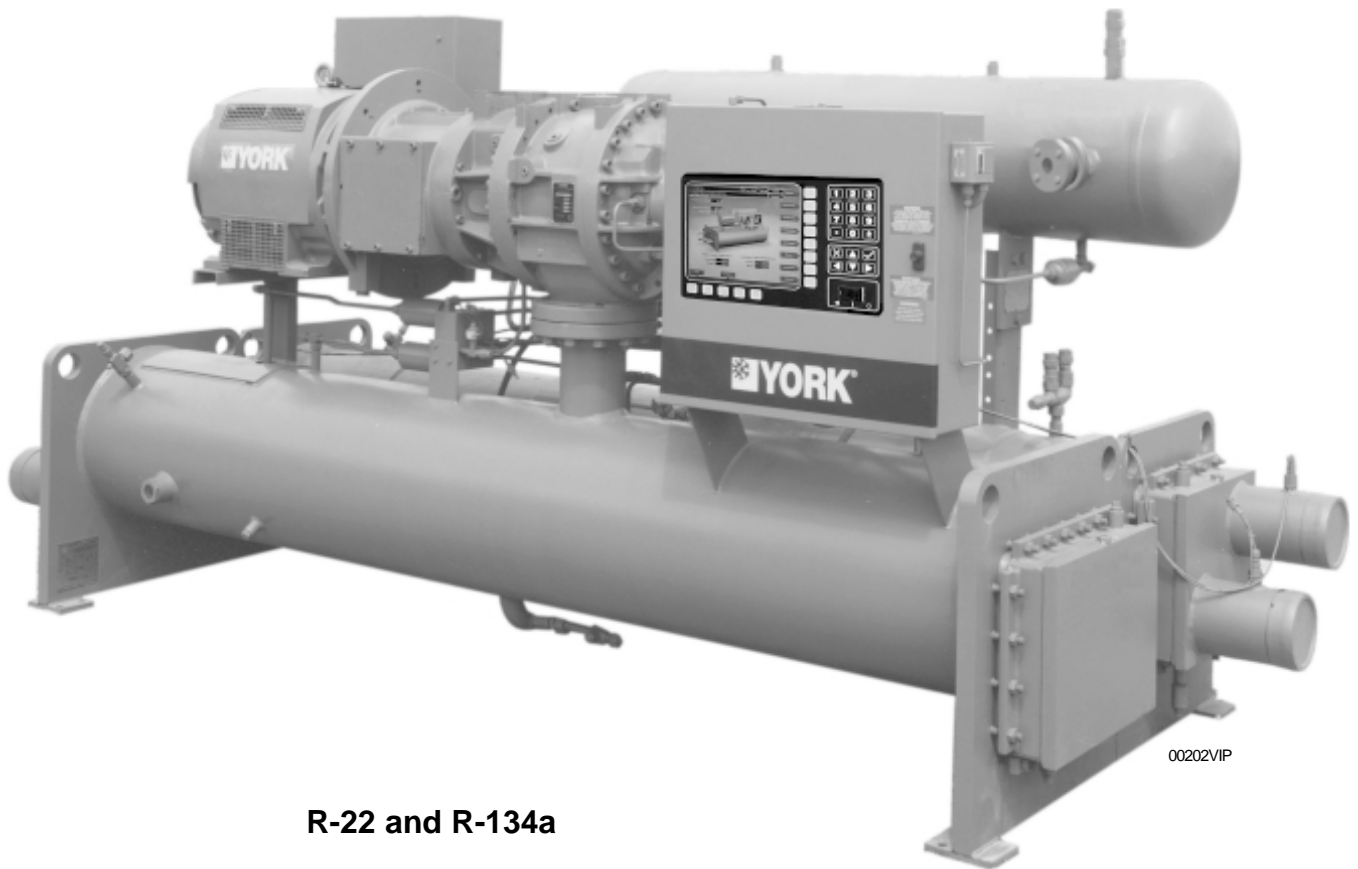

00202VIP

R-22 and R-134a



Metric Conversions



Manufactured in
ISO-Certified Facility

IMPORTANT!

READ BEFORE PROCEEDING!

GENERAL SAFETY GUIDELINES

This equipment is a relatively complicated apparatus. During installation, operation, maintenance or service, individuals may be exposed to certain components or conditions including, but not limited to: refrigerants, oils, materials under pressure, rotating components, and both high and low voltage. Each of these items has the potential, if misused or handled improperly, to cause bodily injury or death. It is the obligation and responsibility of operating/service personnel to identify and recognize these inherent hazards, protect themselves, and proceed safely in completing their tasks. Failure to comply with any of these requirements could result in serious damage to the equipment and the property in which it is

situated, as well as severe personal injury or death to themselves and people at the site.

This document is intended for use by owner-authorized operating/service personnel. It is expected that this individual possesses independent training that will enable them to perform their assigned tasks properly and safely. It is essential that, prior to performing any task on this equipment, this individual shall have read and understood this document and any referenced materials. This individual shall also be familiar with and comply with all applicable governmental standards and regulations pertaining to the task in question.

SAFETY SYMBOLS

The following symbols are used in this document to alert the reader to areas of potential hazard:

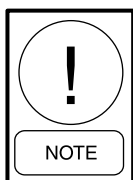

***NOTE** is used to highlight additional information which may be helpful to you.*



***CAUTION** identifies a hazard which could lead to damage to the machine, damage to other equipment and/or environmental pollution. Usually an instruction will be given, together with a brief explanation.*

CHANGEABILITY OF THIS DOCUMENT

In complying with YORK's policy for continuous product improvement, the information contained in this document is subject to change without notice. While YORK makes no commitment to update or provide current information automatically to the manual owner, that information, if applicable, can be obtained by contacting the nearest YORK Applied Systems Service office.

It is the responsibility of operating/service personnel as to the applicability of these documents to the equipment in question. If there is any question in the mind of operating/service personnel as to the applicability of these documents, then, prior to working on the equipment, they should verify with the owner whether the equipment has been modified and if current literature is available.

NOMENCLATURE

The model number denotes the following characteristics of the unit:

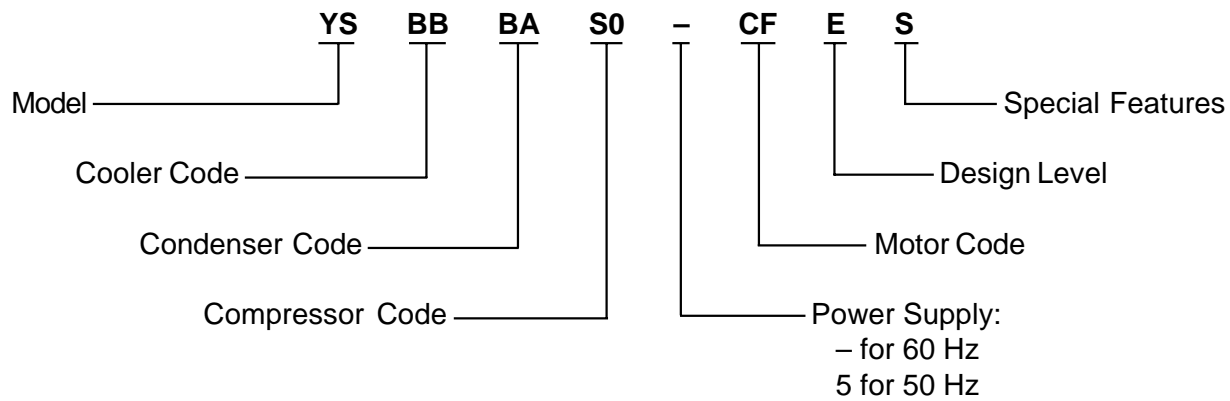

TABLE OF CONTENTS

| | |
|---|----|
| Nomenclature | 3 |
| SECTION 1 INSTALLATION | |
| General | 7 |
| Inspection | 8 |
| Data Plate | 8 |
| Location | 8 |
| Foundation | 8 |
| Clearance | 8 |
| Rigging | 9 |
| Locating and Installing Isolator Pads | 14 |
| Checking the Isolator Pad Deflection | 14 |
| Installing Optional Spring Isolators | 20 |
| Piping Connections | 21 |
| Check for Piping Alignment | 21 |
| Cooler and Condenser Water Piping | 22 |
| Chilled Water Circuit | 22 |
| Condenser Water Circuit | 23 |
| Stop Valves | 23 |
| Flow Switches (Field Installed) | 23 |
| Drain and Vent Valves | 23 |
| Checking Piping Circuits and Venting Air | 24 |
| Refrigerant Relief Piping | 24 |
| Unit Piping | 25 |
| Control Wiring | 25 |
| Power Wiring | 25 |
| Unit with Electro-Mechanical Starter | 25 |
| Unit with Solid State Starter (Optional) | 26 |
| Insulation | 26 |
| Insulation Check – Request for Start-Up Service | 26 |
| SECTION 2 START-UP | |
| Installation Checklist | 28 |
| YS Chiller Commissioning Checklist | 29 |
| YS Chiller Pre-Startup Checklist | 29 |
| YS Chiller Startup | 32 |

TABLE OF CONTENTS

SECTION 3 OPERATION

| | |
|------------------------------------|----|
| Basic Description | 32 |
| Components | 32 |
| Driveline | 32 |
| Oil Separator | 32 |
| Condenser | 32 |
| Evaporator | 32 |
| Condensing Water Temperature | 37 |
| R-22 Refrigerant | 37 |
| R-134a Refrigerant | 37 |
| Oil System | 37 |
| Oil Eductor Circuit | 41 |
| Liquid Refrigerant Circuit | 41 |
| Dual Service Chillers | 41 |
| Capacity Control | 44 |

SECTION 4 MAINTENANCE

| | |
|---|----|
| General | 46 |
| Compressor Oil | 46 |
| Changing Compressor Oil | 46 |
| Oil Level | 47 |
| Oil Filter | 47 |
| Oil Filter Replacement | 47 |
| Single Oil Filter | 47 |
| Dual Oil Filters | 47 |
| Filter Drier Replacement | 49 |
| Motor | 49 |
| Determining Correct Refrigerant Charge Level | 49 |
| Refrigerant Charging | 49 |
| Refrigerant Leak Checking | 50 |
| Pressure Connections | 50 |
| Condenser Tubes | 50 |
| Condenser Water Side Tube Cleaning Procedure | 50 |
| Chemical Cleaning Procedure | 51 |
| Mechanical Cleaning Procedure | 51 |
| Evaporator Tubes | 51 |
| Megging The Motor | 52 |
| Vibration Analysis | 54 |
| Spectral Alarm Bands for 4/6 Lobe Twin Screw Chillers | 55 |
| Oil Recovery | 56 |

LIST OF TABLES

| | | |
|---|--|----|
| 1 | Clearances | 8 |
| 2 | Weights - English, R-22 and R-134a Units, 50 and 60 Hz | 10 |
| 3 | Weights - SI, R-22 and R-134a Units, 50 and 60 Hz | 12 |
| 4 | Refrigerant Relief Characteristics | 25 |
| 5 | Variable Orifice Pressure Differential Setpoints | 41 |
| 6 | YORK Oil Types | 46 |
| 7 | Compressor Oil Limits | 46 |
| 8 | Maintenance Requirements for YORK YS Chillers | 48 |
| 9 | Refrigerant Charge Level | 49 |

LIST OF FIGURES

| | | |
|----|--|----|
| 1 | Model YS Style D Rotary Screw Liquid Chiller | 7 |
| 2 | Rigging | 9 |
| 3 | Standard Neoprene Vibration Isolator Pad Mounts | 15 |
| 4 | Overall Dimensions - English, S0 thru S3 Compressor | 16 |
| 5 | Overall Dimensions - English, S4 and S5 Compressor | 17 |
| 6 | Overall Dimensions - Std. Intl., S0 thru S3 Compressor | 18 |
| 7 | Overall Dimensions - Std. Intl., S4 and S5 Compressor | 19 |
| 8 | Spring Isolators (Optional) | 20 |
| 9 | Schematic of a Typical Piping Arrangement for Cooling Units | 22 |
| 10 | Typical Refrigerant Vent Piping from Relief Valves | 23 |
| 11 | Typical Refrigerant Vent Piping from Rupture Disk | 24 |
| 12 | YS Motor Connections (Electro-Mechanical Starter Application) | 27 |
| 13 | Installation Check List and Request for Authorized Start-Up Engineer | 28 |
| 14 | YS Screw Chiller Component Layout Drawing – Design Level “E” | 34 |
| 15 | YS Screw Chiller Oil Piping Schematic – Design Level “E” | 35 |
| 16 | YS Screw Chiller Optional Dual Oil Filter Piping Schematic – Design Level “E” | 36 |
| 17 | Oil Filter Location | 37 |
| 18 | Oil & Filter Pressure Transducers | 38 |
| 19 | Eductor Block | 38 |
| 20 | YS Screw Chiller Oil Separator Schematic – Design Level “E” | 39 |
| 21 | Filter Driers and Oil Eductor | 41 |
| 22 | YS Screw Chiller Oil Eductor Schematic – Design Level “E” | 42 |
| 23 | YS Screw Chiller Refrigerant Schematic – Design Level “E” | 43 |
| 24 | 4-Way Directional Valve Sub-plate | 44 |
| 25 | Figure To Come | 44 |
| 26 | YS Screw Chiller Capacity Control Piping Schematic – Design Level “E” | 45 |
| 27 | Double Purpose Hydraulic Cylinder | 45 |
| 28 | Oil Heater and Sight Glasses | 47 |
| 29 | Oil Cooler Valve | 50 |
| 30 | Diagram, Megging Motor Windings | 52 |
| 31 | Motor Stator Temperature & Insulation Resistances | 53 |
| 32 | Transducer Measurement Points | 54 |
| 33 | YS Chiller Oil Recovery Guide | 57 |

SECTION 1 – INSTALLATION

GENERAL

This instruction describes the installation of a Model YS Rotary Screw Liquid Chiller. (See Figure 1.) This unit is shipped as a single factory assembled, piped, wired and nitrogen or refrigerant charged package (Form 1 shipment). This unit requires a minimum of field labor to make chilled water connections, condenser water connections, refrigerant atmospheric relief connections, and electrical power connections.

YS units can also be shipped dismantled when required by rigging conditions, but generally it is more economical to enlarge access openings to accommodate the factory assembled unit.

The YS Chiller may be ordered and shipped in the following forms:

- Form 1 – Factory Assembled Unit, Complete with Motor and Refrigerant and Oil Charges as discussed in this instruction.
- Form 2 – Factory Assembled (same as Form 1) except not charged with oil or refrigerant. Shipped with holding charge of nitrogen. Refrigerant shipped in 50 and 125 lb. cylinders.
- Form 3 – Driveline Separate From Shells – Shipped as three major assemblies.
- Form 7 – Split Shells – Shipped as four major assemblies.

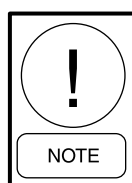

Units shipped dismantled MUST be reassembled by, or under the supervision of a YORK representative. Refer to Form 160.80-N1 for detailed instructions of Form 3 and 7 shipments.

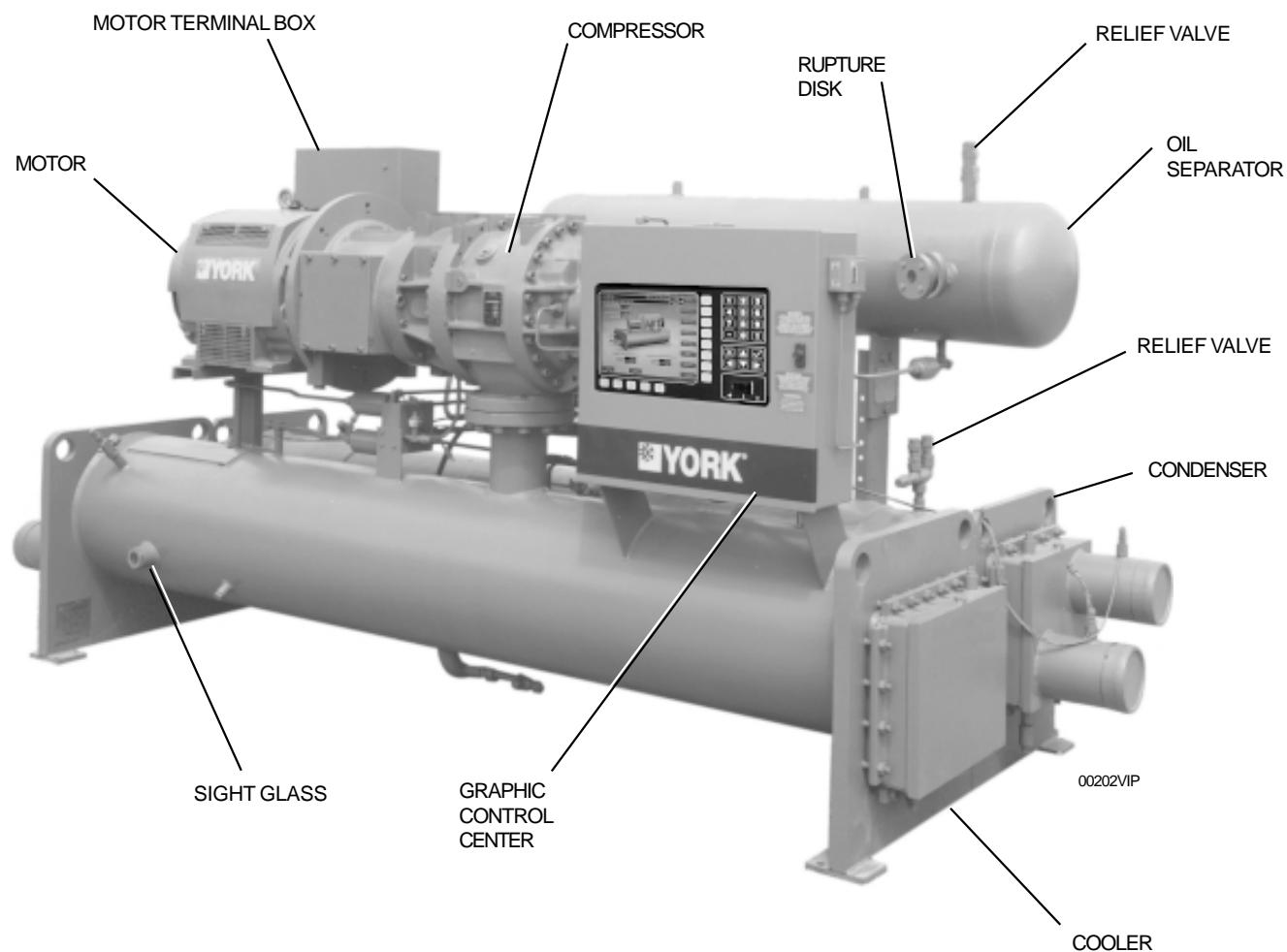

FIG. 1 – MODEL YS, STYLE E ROTARY SCREW LIQUID CHILLER



The YORK Warranty will be voided if the following restrictions are not adhered to:

- 1. No valves or connections should be opened under any circumstances because such action will result in loss of the factory refrigerant or nitrogen charge.***
- 2. Do not dismantle or open the unit for any reason except under the supervision of a YORK representative.***
- 3. When units are shipped dismantled, notify the nearest YORK office in ample time for a YORK representative to supervise rigging the unit to its operating position and the assembly of components.***
- 4. Do not make final power supply connections to the compressor motor or control center.***
- 5. Do not charge the system with oil.***
- 6. Do not attempt to start the system.***
- 7. Do not run hot water (100°F max.) or steam through the cooler or condenser at any time.***

INSPECTION

The unit shipment should be checked on arrival to see that all major pieces, boxes and crates are received. Each unit should be checked on the trailer or rail car when received, before unloading, for any visible signs of damage. Any damage or signs of possible damage must be reported to the transportation company immediately for their inspection.

YORK WILL NOT BE RESPONSIBLE FOR ANY DAMAGE IN SHIPMENT OR AT JOB SITE OR LOSS OF PARTS. (Refer to Shipping Damage Claims, Form 50.15-NM.)

When received at the job site, all containers should be opened and the contents checked against the packing list. Any material shortage should be reported to YORK immediately.

DATA PLATE

A unit data plate is mounted on the control center assembly of each unit, giving unit model number; design working pressure; water passes; refrigerant charge; serial numbers; and motor power characteristics and connection diagrams. Refer to “Nomenclature” on page 3 to verify data plate markings.

LOCATION

The chiller should be located in an indoor location where temperature ranges from 40°F to 110°F (4°C to 43°C).

The units are furnished with neoprene vibration isolator mounts for basement or ground level installations. Units may be located on upper floor levels providing the floor is capable of supporting the total unit operating weight. Refer to Tables 1 and 2.

Equipment room should be ventilated to allow adequate heat removal. Check ANSI, state, local or other codes.

FOUNDATION

A level floor, mounting pad or foundation must be provided by others, capable of supporting the operating weight of the unit.

CLEARANCE

Clearances should be adhered to as follows:

- Rear, Ends and Above Unit – 2 Ft. / 610 mm
- Front of Unit – 3 Ft. / 914 mm
- Tube Removal – See Table 1 below

TABLE 1 – CLEARANCES

| COMPRESSOR | TUBE REMOVAL SPACE | | ADD – MARINE WATER BOXES | |
|----------------|--------------------|-------|--------------------------|-----|
| | Ft. - In. | mm | Ft. - In. | mm |
| S0, S1, S2, S3 | 10'-1" | 3,073 | 1'-6" | 457 |
| S4, S5 | 12'-1" | 3,683 | 1'-9" | 533 |

RIGGING

The complete standard unit is shipped without skids. (When optional skids are used, it may be necessary to remove the skids so riggers skates can be used under the unit end sheets to reduce the overall height.)

Each unit has four lifting holes (two on each end) in the end sheets which should be used to lift the unit. Care should be taken at all times during rigging and handling to avoid damage to the unit and its external connections. Lift only using holes shown in Figure 2.



Do not lift the unit with slings around motor/compressor assembly or by means of eyebolts in the tapped holes of the compressor motor assembly. Do not turn a unit on its side for rigging. Do not rig with driveline in a vertical orientation.



If necessary to rig a unit by one end to permit lifting or dropping through a vertical passageway, such as an elevator shaft, contact YORK Factory for special rigging instructions.

The shipping and operating weights are given in Tables 2 and 3. Overall dimensions are shown in Figures 4 thru 7. More detailed dimensions can be found in Form 160.80-PA1.

If optional shipping skids are used, remove them before lowering the unit to its mounting position. Rig the unit to its final location on the floor or mounting pad by lifting the unit (or shell assembly) with an overhead lift and lower the unit to its mounting position.

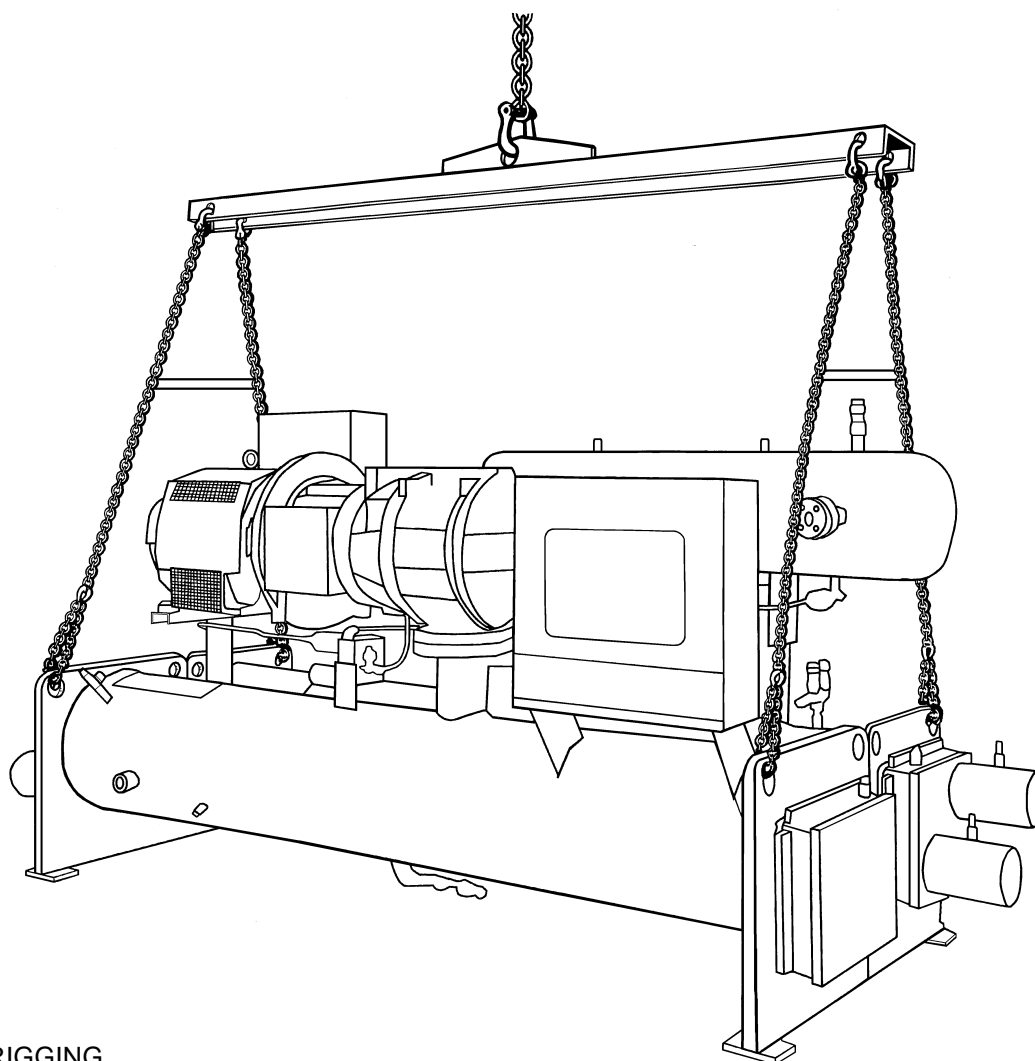

FIG. 2 – RIGGING

TABLE 2 – WEIGHTS - ENGLISH, R-22 AND R-134A UNITS, 50 AND 60 HZ

| SHELL CODE COOLER – COND. | COM-PRES-SOR | SHIP-PING WT. (Lbs.) | OPER-ATING WT. (Lbs.) | REFRIG-ERANT CHARGE (Lbs. R-22) | REFRIG-ERANT CHARGE (Lbs. R-134a) | SHELL CODE COOLER – COND. | COM-PRES-SOR | SHIP-PING WT. (Lbs.) | OPER-ATING WT. (Lbs.) | REFRIG-ERANT CHARGE (Lbs. R-22) | REFRIG-ERANT CHARGE (Lbs. R-134a) |
|---------------------------|--------------|----------------------|-----------------------|---------------------------------|-----------------------------------|---------------------------|--------------|----------------------|-----------------------|---------------------------------|-----------------------------------|
| BA-BA | S0 | 8,388 | 9,019 | 490 | 441 | CA-DA | S2 | 13,357 | 14,765 | 750 | 675 |
| BA-BB | S0 | 8,538 | 9,235 | 490 | 441 | CA-DB | S2 | 13,874 | 15,506 | 750 | 675 |
| BB-BA | S0 | 8,494 | 9,187 | 460 | 414 | CB-DA | S2 | 13,588 | 15,093 | 750 | 675 |
| BB-BB | S0 | 8,644 | 9,403 | 460 | 414 | CB-DB | S2 | 14,105 | 15,833 | 750 | 675 |
| BA-CA | S0 | 9,142 | 9,996 | 520 | 468 | DA-CA | S2 | 13,293 | 14,480 | 840 | 756 |
| BA-CB | S0 | 9,416 | 10,388 | 520 | 468 | DA-CB | S2 | 13,577 | 14,872 | 840 | 756 |
| BB-CA | S0 | 9,271 | 10,186 | 480 | 432 | DB-CA | S2 | 13,668 | 15,008 | 840 | 756 |
| BB-CB | S0 | 9,545 | 10,579 | 480 | 432 | DB-CB | S2 | 13,941 | 15,400 | 840 | 756 |
| CA-BA | S0 | 9,297 | 10,084 | 620 | 558 | DC-CA | S2 | 14,026 | 15,552 | 840 | 756 |
| CA-BB | S0 | 9,448 | 10,299 | 620 | 558 | DC-CB | S2 | 14,299 | 15,943 | 840 | 756 |
| CB-BA | S0 | 9,528 | 10,412 | 620 | 558 | DA-DA | S2 | 14,549 | 16,124 | 950 | 855 |
| CB-BB | S0 | 9,679 | 10,627 | 620 | 558 | DA-DB | S2 | 15,066 | 16,864 | 950 | 855 |
| CA-CA | S0 | 10,011 | 11,020 | 650 | 585 | DB-DA | S2 | 14,869 | 16,608 | 910 | 819 |
| CA-CB | S0 | 10,285 | 11,413 | 650 | 585 | DB-DB | S2 | 15,386 | 17,348 | 910 | 819 |
| CB-CA | S0 | 10,242 | 11,348 | 650 | 585 | DC-DA | S2 | 15,215 | 17,437 | 840 | 756 |
| CB-CB | S0 | 10,516 | 11,740 | 650 | 585 | DC-DB | S2 | 15,732 | 16,781 | 840 | 756 |
| BA-BA | S1 | 8,454 | 9,085 | 490 | 441 | CA-CA | S3 | 12,360 | 13,372 | — | 612 |
| BA-BB | S1 | 8,608 | 9,301 | 490 | 441 | CA-CB | S3 | 12,633 | 13,764 | — | 612 |
| BB-BA | S1 | 8,560 | 9,253 | 460 | 414 | CB-CA | S3 | 12,591 | 13,698 | — | 612 |
| BB-BB | S1 | 8,711 | 9,469 | 460 | 414 | CB-CB | S3 | 12,865 | 14,090 | — | 612 |
| BA-CA | S1 | 9,208 | 9,974 | 520 | 468 | CA-DA | S3 | 13,574 | 14,983 | — | 675 |
| BA-CB | S1 | 9,482 | 10,454 | 520 | 468 | CA-DB | S3 | 14,090 | 15,726 | — | 675 |
| BB-CA | S1 | 9,337 | 10,252 | 480 | 432 | CB-DA | S3 | 13,804 | 15,313 | — | 675 |
| BB-CB | S1 | 9,611 | 10,645 | 480 | 432 | CB-DB | S3 | 14,324 | 16,054 | — | 675 |
| CA-BA | S1 | 9,363 | 10,150 | 620 | 558 | DA-CA | S3 | 13,497 | 14,673 | 840 | 756 |
| CA-BB | S1 | 9,513 | 10,365 | 620 | 558 | DA-CB | S3 | 13,770 | 15,065 | 840 | 756 |
| CB-BA | S1 | 9,594 | 10,478 | 620 | 558 | DB-CA | S3 | 13,861 | 15,201 | 840 | 756 |
| CB-BB | S1 | 9,745 | 10,693 | 620 | 558 | DB-CB | S3 | 14,134 | 15,593 | 840 | 756 |
| CA-CA | S1 | 10,077 | 11,086 | 650 | 585 | DC-CA | S3 | 14,219 | 15,744 | 840 | 756 |
| CA-CB | S1 | 10,351 | 11,479 | 650 | 585 | DC-CB | S3 | 14,491 | 16,135 | 840 | 756 |
| CB-CA | S1 | 10,308 | 11,414 | 650 | 585 | DA-DA | S3 | 14,741 | 16,316 | 950 | 855 |
| CB-CB | S1 | 10,582 | 11,806 | 650 | 585 | DA-DB | S3 | 15,258 | 17,057 | 950 | 855 |
| BA-BA | S2 | 10,542 | 11,174 | — | 441 | DB-DA | S3 | 15,061 | 16,800 | 910 | 819 |
| BA-BB | S2 | 10,693 | 11,390 | — | 441 | DB-DB | S3 | 15,578 | 17,541 | 910 | 819 |
| BB-BA | S2 | 10,648 | 11,342 | — | 414 | DC-DA | S3 | 15,408 | 17,333 | 840 | 756 |
| BB-BB | S2 | 10,797 | 11,558 | — | 414 | DC-DB | S3 | 15,925 | 18,073 | 840 | 756 |
| BA-CA | S2 | 11,298 | 12,065 | — | 468 | DA-CA | S4 | 17,068 | 18,247 | — | 740 |
| BA-CB | S2 | 11,571 | 12,547 | — | 468 | DA-CB | S4 | 17,341 | 18,639 | — | 740 |
| BB-CA | S2 | 11,426 | 12,342 | — | 432 | DB-CA | S4 | 17,431 | 18,776 | — | 740 |
| BB-CB | S2 | 11,701 | 12,735 | — | 432 | DB-CB | S4 | 17,705 | 19,168 | — | 740 |
| CA-BA | S2 | 11,452 | 12,241 | — | 558 | DC-CA | S4 | 17,791 | 19,320 | — | 740 |
| CA-BB | S2 | 11,604 | 12,457 | — | 558 | DC-CB | S4 | 18,064 | 19,710 | — | 740 |
| CB-BA | S2 | 11,683 | 12,567 | — | 558 | DA-DA | S4 | 18,313 | 19,893 | — | 830 |
| CB-BB | S2 | 11,833 | 12,783 | — | 558 | DA-DB | S4 | 18,833 | 20,634 | — | 830 |
| CA-CA | S2 | 12,146 | 13,155 | 680 | 612 | DB-DA | S4 | 18,635 | 20,378 | — | 800 |
| CA-CB | S2 | 12,419 | 13,547 | 680 | 612 | DB-DB | S4 | 19,153 | 21,119 | — | 800 |
| CB-CA | S2 | 12,377 | 13,483 | 680 | 612 | DC-DA | S4 | 18,983 | 20,912 | — | 740 |
| CB-CB | S2 | 12,650 | 13,874 | 680 | 612 | DC-DB | S4 | 19,426 | 21,652 | — | 740 |

TABLE 2 – WEIGHTS - ENGLISH, R-22 AND R-134A UNITS, 50 AND 60 HZ (CONT'D)

| SHELL CODE COOLER – COND. | COM-PRES-SOR | SHIP-PING WT. (Lbs.) | OPER-ATING WT. (Lbs.) | REFRIG-ERANT CHARGE (Lbs. R-22) | REFRIG-ERANT CHARGE (Lbs. R-134a) | SHELL CODE COOLER – COND. | COM-PRES-SOR | SHIP-PING WT. (Lbs.) | OPER-ATING WT. (Lbs.) | REFRIG-ERANT CHARGE (Lbs. R-22) | REFRIG-ERANT CHARGE (Lbs. R-134a) |
|---------------------------|--------------|----------------------|-----------------------|---------------------------------|-----------------------------------|---------------------------|--------------|----------------------|-----------------------|---------------------------------|-----------------------------------|
| EA-EA | S4 | 20,460 | 21,890 | 1,400 | 1,260 | EA-EA | S5 | 20,777 | 22,210 | — | 1,260 |
| EA-EB | S4 | 21,104 | 22,743 | 1,400 | 1,260 | EA-EB | S5 | 21,423 | 23,065 | — | 1,260 |
| EB-EA | S4 | 20,955 | 22,484 | 1,350 | 1,215 | EB-EA | S5 | 21,275 | 22,807 | — | 1,215 |
| EB-EB | S4 | 21,533 | 23,337 | 1,350 | 1,215 | EB-EB | S5 | 21,853 | 23,682 | — | 1,215 |
| EC-EA | S4 | 21,362 | 23,139 | 1,300 | 1,170 | EC-EA | S5 | 21,681 | 23,462 | — | 1,170 |
| EC-EB | S4 | 22,000 | 23,991 | 1,300 | 1,170 | EC-EB | S5 | 22,322 | 24,317 | — | 1,170 |
| EA-FA | S4 | 23,485 | 25,592 | 1,520 | 1,368 | EA-FA | S5 | 23,808 | 25,919 | — | 1,368 |
| EA-FB | S4 | 24,695 | 27,192 | 1,520 | 1,368 | EA-FB | S5 | 25,020 | 27,521 | — | 1,368 |
| EB-FA | S4 | 23,914 | 26,180 | 1,520 | 1,368 | EB-FA | S5 | 24,240 | 26,508 | — | 1,368 |
| EB-FB | S4 | 25,119 | 27,781 | 1,450 | 1,305 | EB-FB | S5 | 25,445 | 28,112 | — | 1,305 |
| EC-FA | S4 | 24,382 | 26,840 | 1,450 | 1,305 | EC-FA | S5 | 24,707 | 27,171 | — | 1,305 |
| EC-FB | S4 | 25,592 | 28,435 | 1,450 | 1,305 | EC-FB | S5 | 25,919 | 28,769 | — | 1,305 |
| FA-EA | S4 | 22,922 | 24,998 | — | 1,690 | FA-EA | S5 | 23,274 | 25,280 | — | 1,690 |
| FA-EB | S4 | 23,638 | 25,853 | — | 1,690 | FA-EB | S5 | 23,920 | 26,135 | — | 1,690 |
| FB-EA | S4 | 23,711 | 25,902 | — | 1,690 | FB-EA | S5 | 23,991 | 26,184 | — | 1,690 |
| FB-EB | S4 | 24,288 | 26,757 | — | 1,690 | FB-EB | S5 | 24,568 | 27,036 | — | 1,620 |
| FC-EA | S4 | 24,171 | 27,076 | — | 1,620 | FC-EA | S5 | 24,453 | 27,356 | — | 1,620 |
| FC-EB | S4 | 25,141 | 27,929 | — | 1,620 | FC-EB | S5 | 25,423 | 28,211 | — | 1,620 |
| FA-FA | S4 | 25,977 | 28,655 | 2,000 | 1,800 | FA-FA | S5 | 26,257 | 28,936 | 2,000 | 1,800 |
| FA-FB | S4 | 27,187 | 30,256 | 2,000 | 1,800 | FA-FB | S5 | 27,467 | 30,536 | 2,000 | 1,800 |
| FB-FA | S4 | 26,626 | 29,552 | 2,000 | 1,800 | FB-FA | S5 | 26,906 | 29,832 | 2,000 | 1,800 |
| FB-FB | S4 | 27,830 | 31,152 | 1,900 | 1,710 | FB-FB | S5 | 28,111 | 31,433 | 1,900 | 1,710 |
| FC-FA | S4 | 27,148 | 30,729 | 1,900 | 1,710 | FC-FA | S5 | 27,759 | 31,009 | 1,900 | 1,710 |
| FC-FB | S4 | 28,688 | 32,324 | 1,900 | 1,710 | FC-FB | S5 | 28,969 | 32,604 | 1,900 | 1,710 |

- NOTES:**
1. Calculate total chiller weight by adding motor weight, solid state starter weight, and marine water box weights, if applicable.
 2. Shipping weight includes refrigerant and oil charge. Operating weight includes water in tubes and water boxes.
 3. Weights based on standard tubes in coolers and condensers.
 4. Operating weight based on R-22. Subtract difference in refrigerant charge if using R-134a.

TABLE 3 – WEIGHTS - SI, R-22 AND R-134A UNITS, 50 AND 60 HZ

| SHELL CODE COOLER – COND. | COM-PRES-SOR | SHIP-PING WT. (Kgs.) | OPER-ATING WT. (Kgs.) | REFRIG-ERANT CHARGE (Kgs. R-22) | REFRIG-ERANT CHARGE (Kgs. R-134a) | SHELL CODE COOLER – COND. | COM-PRES-SOR | SHIP-PING WT. (Kgs.) | OPER-ATING WT. (Kgs.) | REFRIG-ERANT CHARGE (Kgs. R-22) | REFRIG-ERANT CHARGE (Kgs. R-134a) |
|---------------------------|--------------|----------------------|-----------------------|---------------------------------|-----------------------------------|---------------------------|--------------|----------------------|-----------------------|---------------------------------|-----------------------------------|
| BA-BA | S0 | 3,805 | 4,091 | 222 | 200 | CA-DA | S2 | 6,059 | 6,697 | 340 | 306 |
| BA-BB | S0 | 3,873 | 4,189 | 222 | 200 | CA-DB | S2 | 6,293 | 7,034 | 340 | 306 |
| BB-BA | S0 | 3,853 | 4,167 | 209 | 188 | CB-DA | S2 | 6,164 | 6,846 | 340 | 306 |
| BB-BB | S0 | 3,921 | 4,265 | 209 | 188 | CB-DB | S2 | 6,398 | 7,182 | 340 | 306 |
| BA-CA | S0 | 4,147 | 4,534 | 236 | 212 | DA-CA | S2 | 6,030 | 6,568 | 381 | 343 |
| BA-CB | S0 | 4,271 | 4,712 | 236 | 212 | DA-CB | S2 | 6,159 | 6,746 | 381 | 343 |
| BB-CA | S0 | 4,205 | 4,620 | 218 | 196 | DB-CA | S2 | 6,200 | 6,808 | 381 | 343 |
| BB-CB | S0 | 4,330 | 4,799 | 218 | 196 | DB-CB | S2 | 6,324 | 6,985 | 381 | 343 |
| CA-BA | S0 | 4,217 | 4,574 | 281 | 253 | DC-CA | S2 | 6,362 | 7,054 | 381 | 343 |
| CA-BB | S0 | 4,286 | 4,672 | 281 | 253 | DC-CB | S2 | 6,486 | 7,232 | 381 | 343 |
| CB-BA | S0 | 4,322 | 4,723 | 281 | 253 | DA-DA | S2 | 6,599 | 7,314 | 431 | 388 |
| CB-BB | S0 | 4,390 | 4,820 | 281 | 253 | DA-DB | S2 | 6,834 | 7,650 | 431 | 388 |
| CA-CA | S0 | 4,541 | 4,999 | 295 | 265 | DB-DA | S2 | 6,745 | 7,533 | 413 | 371 |
| CA-CB | S0 | 4,665 | 5,177 | 295 | 265 | DB-DB | S2 | 6,979 | 7,869 | 413 | 371 |
| CB-CA | S0 | 4,646 | 5,147 | 295 | 265 | DC-DA | S2 | 6,902 | 7,909 | 381 | 343 |
| CB-CB | S0 | 4,770 | 5,325 | 295 | 265 | DC-DB | S2 | 7,136 | 7,612 | 381 | 343 |
| BA-BA | S1 | 3,835 | 4,121 | 222 | 200 | CA-CA | S3 | 5,606 | 6,066 | — | 278 |
| BA-BB | S1 | 3,905 | 4,219 | 222 | 200 | CA-CB | S3 | 5,730 | 6,243 | — | 278 |
| BB-BA | S1 | 3,883 | 4,197 | 209 | 188 | CB-CA | S3 | 5,711 | 6,213 | — | 278 |
| BB-BB | S1 | 3,951 | 4,295 | 209 | 188 | CB-CB | S3 | 5,836 | 6,391 | — | 278 |
| BA-CA | S1 | 4,177 | 4,524 | 236 | 212 | CA-DA | S3 | 6,157 | 6,796 | — | 306 |
| BA-CB | S1 | 4,301 | 4,742 | 236 | 212 | CA-DB | S3 | 6,391 | 7,133 | — | 306 |
| BB-CA | S1 | 4,235 | 4,650 | 218 | 196 | CB-DA | S3 | 6,261 | 6,946 | — | 306 |
| BB-CB | S1 | 4,360 | 4,829 | 218 | 196 | CB-DB | S3 | 6,497 | 7,282 | — | 306 |
| CA-BA | S1 | 4,247 | 4,604 | 281 | 253 | DA-CA | S3 | 6,122 | 6,656 | 381 | 343 |
| CA-BB | S1 | 4,315 | 4,702 | 281 | 253 | DA-CB | S3 | 6,246 | 6,833 | 381 | 343 |
| CB-BA | S1 | 4,352 | 4,753 | 281 | 253 | DB-CA | S3 | 6,287 | 6,895 | 381 | 343 |
| CB-BB | S1 | 4,420 | 4,850 | 281 | 253 | DB-CB | S3 | 6,411 | 7,073 | 381 | 343 |
| CA-CA | S1 | 4,571 | 5,029 | 295 | 265 | DC-CA | S3 | 6,450 | 7,141 | 381 | 343 |
| CA-CB | S1 | 4,695 | 5,207 | 295 | 265 | DC-CB | S3 | 6,573 | 7,319 | 381 | 343 |
| CB-CA | S1 | 4,676 | 5,177 | 295 | 265 | DA-DA | S3 | 6,687 | 7,401 | 431 | 388 |
| CB-CB | S1 | 4,800 | 5,355 | 295 | 265 | DA-DB | S3 | 6,921 | 7,737 | 431 | 388 |
| BA-BA | S2 | 4,782 | 5,069 | — | 200 | DB-DA | S3 | 6,832 | 7,620 | 413 | 371 |
| BA-BB | S2 | 4,850 | 5,167 | — | 200 | DB-DB | S3 | 7,066 | 7,957 | 413 | 371 |
| BB-BA | S2 | 4,830 | 5,145 | — | 188 | DC-DA | S3 | 6,989 | 7,862 | 381 | 343 |
| BB-BB | S2 | 4,898 | 5,243 | — | 188 | DC-DB | S3 | 7,224 | 8,198 | 381 | 343 |
| BA-CA | S2 | 5,125 | 5,473 | — | 212 | DA-CA | S4 | 7,742 | 8,277 | — | 336 |
| BA-CB | S2 | 5,249 | 5,691 | — | 212 | DA-CB | S4 | 7,866 | 8,455 | — | 336 |
| BB-CA | S2 | 5,183 | 5,598 | — | 196 | DB-CA | S4 | 7,907 | 8,517 | — | 336 |
| BB-CB | S2 | 5,308 | 5,777 | — | 196 | DB-CB | S4 | 8,031 | 8,695 | — | 336 |
| CA-BA | S2 | 5,195 | 5,553 | — | 253 | DC-CA | S4 | 8,070 | 8,764 | — | 336 |
| CA-BB | S2 | 5,264 | 5,650 | — | 253 | DC-CB | S4 | 8,194 | 8,940 | — | 336 |
| CB-BA | S2 | 5,299 | 5,700 | — | 253 | DA-DA | S4 | 8,307 | 9,023 | — | 376 |
| CB-BB | S2 | 5,367 | 5,798 | — | 253 | DA-DB | S4 | 8,543 | 9,360 | — | 376 |
| CA-CA | S2 | 5,509 | 5,967 | 308 | 278 | DB-DA | S4 | 8,453 | 9,243 | — | 363 |
| CA-CB | S2 | 5,633 | 6,145 | 308 | 278 | DB-DB | S4 | 8,688 | 9,580 | — | 363 |
| CB-CA | S2 | 5,614 | 6,116 | 308 | 278 | DC-DA | S4 | 8,611 | 9,486 | — | 336 |
| CB-CB | S2 | 5,738 | 6,293 | 308 | 278 | DC-DB | S4 | 8,812 | 9,821 | — | 336 |

TABLE 3 – WEIGHTS - SI, R-22 AND R-134A UNITS, 50 AND 60 HZ (CONT'D)

| SHELL CODE COOLER – COND. | COM-PRES-SOR | SHIP-PING WT. (Kgs.) | OPER-ATING WT. (Kgs.) | REFRIG-ERANT CHARGE (Kgs. R-22) | REFRIG-ERANT CHARGE (Kgs. R-134a) | SHELL CODE COOLER – COND. | COM-PRES-SOR | SHIP-PING WT. (Kgs.) | OPER-ATING WT. (Kgs.) | REFRIG-ERANT CHARGE (Kgs. R-22) | REFRIG-ERANT CHARGE (Kgs. R-134a) |
|---------------------------|--------------|----------------------|-----------------------|---------------------------------|-----------------------------------|---------------------------|--------------|----------------------|-----------------------|---------------------------------|-----------------------------------|
| EA-EA | S4 | 9,281 | 9,929 | 635 | 572 | EA-EA | S5 | 9,424 | 10,074 | — | 572 |
| EA-EB | S4 | 9,573 | 10,316 | 635 | 572 | EA-EB | S5 | 9,717 | 10,462 | — | 572 |
| EB-EA | S4 | 9,505 | 10,199 | 612 | 551 | EB-EA | S5 | 9,650 | 10,345 | — | 551 |
| EB-EB | S4 | 9,767 | 10,586 | 612 | 551 | EB-EB | S5 | 9,913 | 10,742 | — | 551 |
| EC-EA | S4 | 9,690 | 10,496 | 590 | 531 | EC-EA | S5 | 9,835 | 10,642 | — | 531 |
| EC-EB | S4 | 9,979 | 10,882 | 590 | 531 | EC-EB | S5 | 10,125 | 11,030 | — | 531 |
| EA-FA | S4 | 10,653 | 11,609 | 689 | 621 | EA-FA | S5 | 10,799 | 11,757 | — | 621 |
| EA-FB | S4 | 11,202 | 12,334 | 689 | 621 | EA-FB | S5 | 11,349 | 12,484 | — | 621 |
| EB-FA | S4 | 10,847 | 11,875 | 689 | 621 | EB-FA | S5 | 10,995 | 12,024 | — | 621 |
| EB-FB | S4 | 11,394 | 12,601 | 658 | 592 | EB-FB | S5 | 11,542 | 12,752 | — | 592 |
| EC-FA | S4 | 11,060 | 12,175 | 658 | 592 | EC-FA | S5 | 11,207 | 12,325 | — | 592 |
| EC-FB | S4 | 11,609 | 12,898 | 658 | 592 | EC-FB | S5 | 11,757 | 13,050 | — | 592 |
| FA-EA | S4 | 10,397 | 11,339 | — | 767 | FA-EA | S5 | 10,557 | 11,467 | — | 767 |
| FA-EB | S4 | 10,722 | 11,727 | — | 767 | FA-EB | S5 | 10,850 | 11,855 | — | 767 |
| FB-EA | S4 | 10,755 | 11,749 | — | 767 | FB-EA | S5 | 10,882 | 11,877 | — | 767 |
| FB-EB | S4 | 11,017 | 12,137 | — | 767 | FB-EB | S5 | 11,144 | 12,264 | — | 735 |
| FC-EA | S4 | 10,964 | 12,282 | — | 735 | FC-EA | S5 | 11,092 | 12,409 | — | 735 |
| FC-EB | S4 | 11,404 | 12,669 | — | 735 | FC-EB | S5 | 11,532 | 12,797 | — | 735 |
| FA-FA | S4 | 11,783 | 12,998 | 907 | 816 | FA-FA | S5 | 11,910 | 13,125 | 907 | 816 |
| FA-FB | S4 | 12,332 | 13,724 | 907 | 816 | FA-FB | S5 | 12,459 | 13,851 | 907 | 816 |
| FB-FA | S4 | 12,078 | 13,405 | 907 | 816 | FB-FA | S5 | 12,205 | 13,532 | 907 | 816 |
| FB-FB | S4 | 12,624 | 14,131 | 862 | 776 | FB-FB | S5 | 12,751 | 14,258 | 862 | 776 |
| FC-FA | S4 | 12,314 | 13,939 | 862 | 776 | FC-FA | S5 | 12,591 | 14,066 | 862 | 776 |
| FC-FB | S4 | 13,013 | 14,662 | 862 | 776 | FC-FB | S5 | 13,140 | 14,789 | 862 | 776 |

- NOTES:**
1. Calculate total chiller weight by adding motor weight, solid state starter weight, and marine water box weights, if applicable.
 2. Shipping weight includes refrigerant and oil charge. Operating weight includes water in tubes and water boxes.
 3. Weights based on standard tubes in coolers and condensers.
 4. Operating weight based on R-22. Subtract difference in refrigerant charge if using R-134a.

RIGGING (CONT'D)

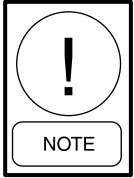

Units shipped dismantled should be assembled under the supervision of a YORK representative.

If the cooler is to be field insulated, the insulation should be applied while the unit is in the lift position, before the unit is placed in position.

LOCATING AND INSTALLING ISOLATOR PADS

The isolator pads should be located in accordance with the floor layout of the dimensional product drawing, Form 160.47-PA1. After the isolator pads have been placed into position on the floor, lower the unit onto the pads. Make sure the pads are even with the edges of the mounting feet. When the unit is in place, remove the rigging equipment and check that the chiller is level, both longitudinally and transversely. See Figure 3.

The longitudinal alignment of the unit should be checked by placing a level on the top center of the cooler shell **under the compressor/motor assembly**. Transverse alignment should be checked by placing a level on top of the shell end sheets at each end of the unit.

The unit should be level within 1/4 inch from one end to the other end and from front to the rear. If the chiller is not level within the amount specified, lift it and place shims between the isolation pad and the tube sheets.

CHECKING THE ISOLATOR PAD DEFLECTION

All isolator pads should be checked for the proper deflection while checking the level of the unit. Each pad should be deflected approximately 0.15 inch (4mm). If an isolator pad is under deflected, shims should be placed between the unit tube sheet and the top of the pad to equally deflect all pads. Refer to Figure 3.

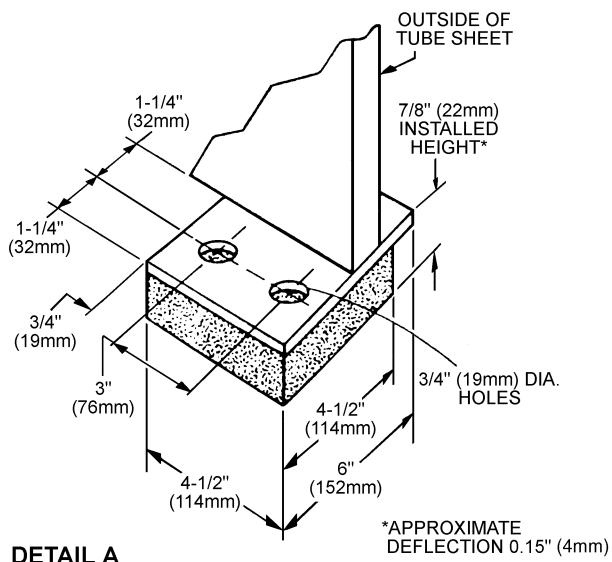

LD02942

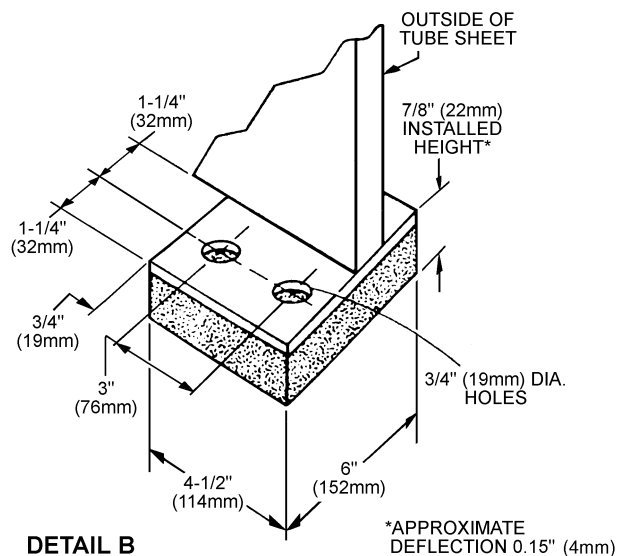

LD02943

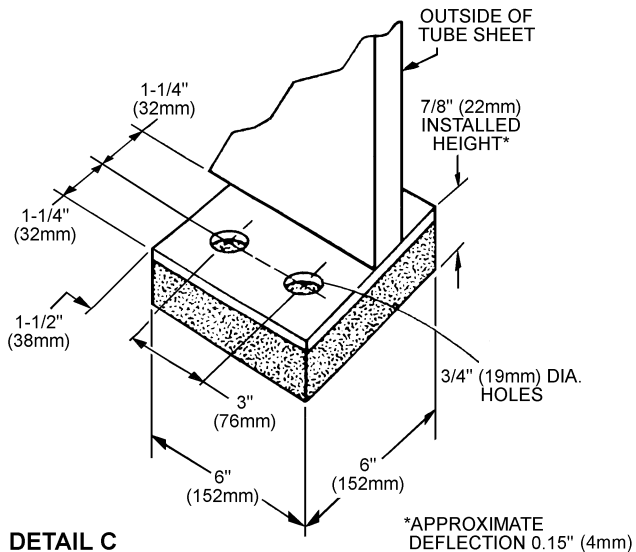

LD02944

| OPERATING WEIGHT (Lbs. / Kgs.) | DETAIL |
|------------------------------------|----------|
| UP TO 16,365 / 7,423 | A |
| 16,636 / 7,546 to 28,835 / 13,080 | B |
| 28,836 / 13,080 to 53,530 / 24,281 | C |

FIG. 3 – STANDARD NEOPRENE VIBRATION ISOLATOR PAD MOUNTS

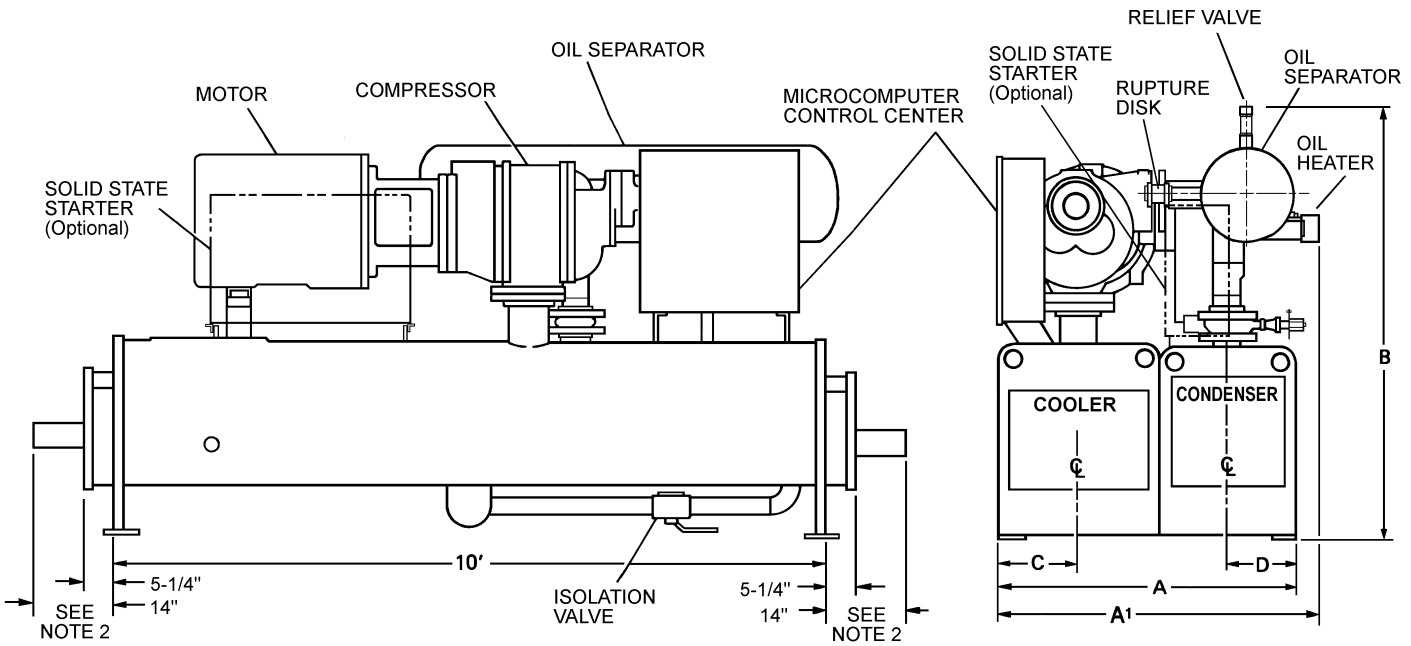

LD00068

| DIMENSION | S0 and S1 COMPRESSOR | | | | S2 COMPRESSOR | | | S2 and S3 COMPRESSOR | | | |
|---------------------------------|----------------------------------|------------|------------|------------|---------------|-----------|-----------|----------------------|-----------|-----------|-----------|
| | SHELL CODES (Cooler - Condenser) | | | | | | | | | | |
| | B-B | B-C | C-B | C-C | B-B | B-C | C-B | C-C | C-D | D-C | D-D |
| A - TUBE SHEET WIDTH | 4'-2-7/8" | | | | 5'-2-1/2" | | | 5'-2-1/2" | | | |
| A ¹ - OVERALL WIDTH | 4'-6-3/4" | 4'-6-1/4" | 4'-6-3/4" | 4'-6-1/4" | 5'-3-3/4" | | | 5'-3-3/4" | | | |
| B - OVERALL HEIGHT ³ | 5'-8-5/8" | 5'-11-1/2" | 5'-10-1/4" | 5'-11-1/2" | 5'-11-1/4" | 6'-3-1/4" | 6'-3-1/4" | 6'-3-1/4" | 6'-7-5/8" | 6'-8-3/4" | 6'-9-3/8" |
| C - COOLER C/L | 1'-1-7/8" | | | | 1'-5" | | | 1'-5" | | | |
| D - CONDENSER C/L | 0'-11-5/8" | | | | 1'-2-1/4" | | | 1'-2-1/4" | | | |

FIG. 4 - OVERALL DIMENSIONS - ENGLISH, S0 THRU S3 COMPRESSOR

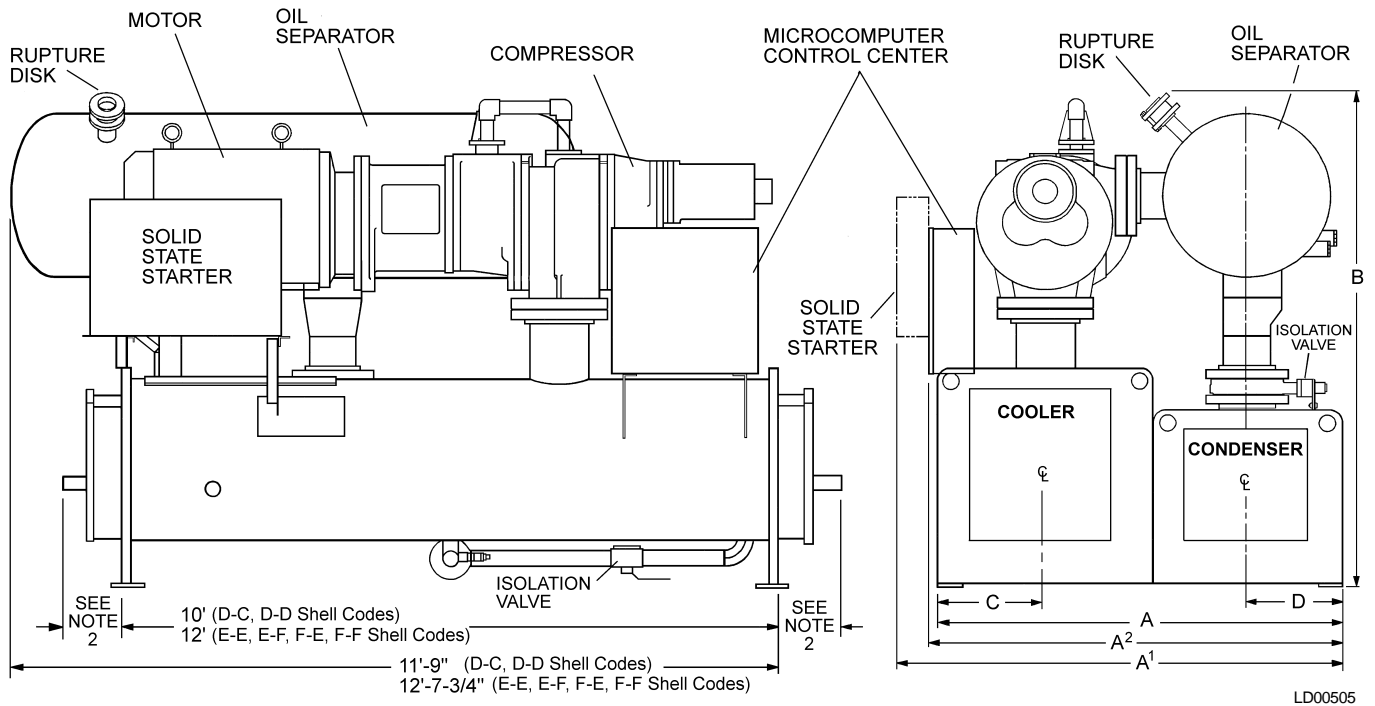

| DIMENSION | S4 COMPRESSOR | | S4 and S5 COMPRESSOR | | | |
|---|----------------------------------|-----------|----------------------|-----------|-----------|-----------|
| | SHELL CODES (Cooler - Condenser) | | | | | |
| | D-C | D-D | E-E | E-F | F-E | F-F |
| A TUBE SHEET WIDTH | 6'-2" | 6'-2" | 6'-2" | 6'-4-1/2" | 6'-6-1/2" | 6'-9" |
| A ¹ - With SSS | 6'-9-7/8" | 6'-9-7/8" | 6'-9-7/8" | 7'-0-3/8" | 7'-3-5/8" | 7'-2-5/8" |
| A ² - OVERALL WD. (less SSS) | 6'-3-3/8" | 6'-3-3/8" | 6'-2" | 6'-4-1/2" | 6'-6-1/2" | 6'-9" |
| B - OVERALL HEIGHT ³ | 7'-9-1/8" | 7'-9-1/8" | 7'-9-1/8" | 8'-2-1/4" | 8'-2-1/4" | 8'-2-1/4" |
| C - COOLER C/L | 1'-7-3/4" | 1'-7-3/4" | 1'-7-3/4" | 1'-7-3/4" | 1'-10" | 1'-10" |
| D - CONDENSER C/L | 1'-5-1/4" | 1'-5-1/4" | 1'-5-1/4" | 1'-6-1/2" | 1'-5-1/4" | 1'-6-1/2" |

FIG. 5 - OVERALL DIMENSIONS - ENGLISH, S4 AND S5 COMPRESSOR

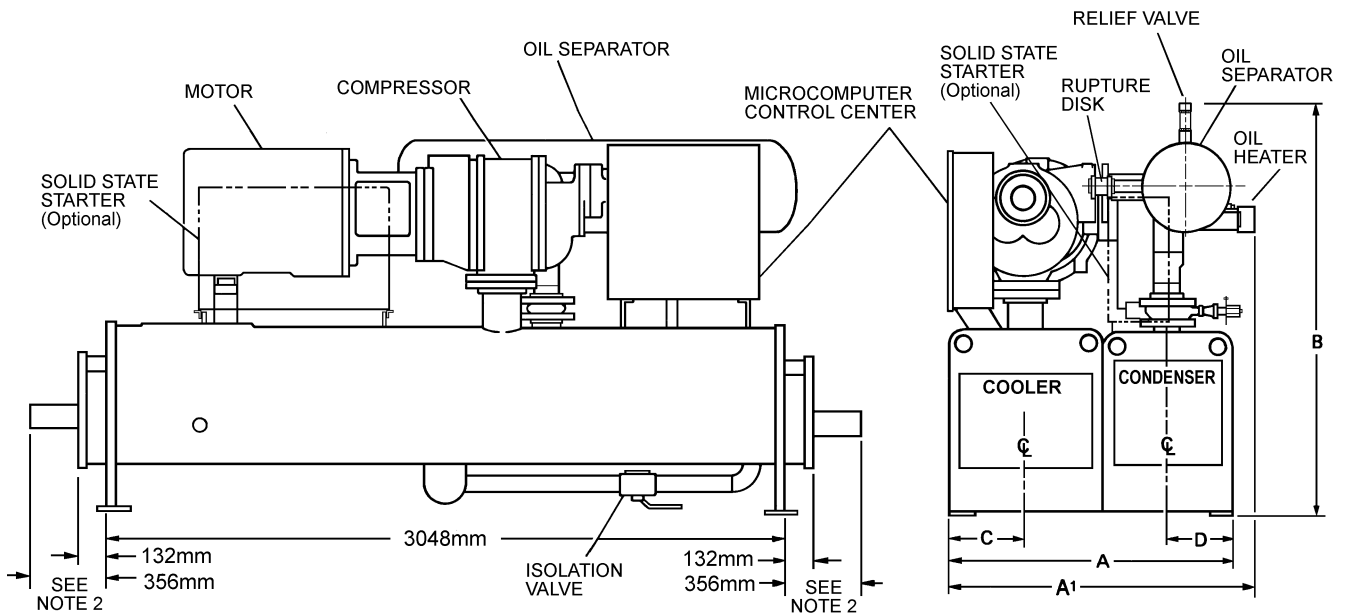

LD00506

| DIMENSION | S0 and S1 COMPRESSOR | | | | S2 COMPRESSOR | | | | S2 and S3 COMPRESSOR | | | |
|---------------------------------|----------------------------------|-------|-------|-------|---------------|-------|-------|-------|----------------------|-------|-------|--|
| | SHELL CODES (Cooler – Condenser) | | | | | | | | | | | |
| | B-B | B-C | C-B | C-C | B-B | B-C | C-B | C-C | C-D | D-C | D-D | |
| A – TUBE SHEET WIDTH | 1,292 | 1,292 | 1,292 | 1,292 | 1,588 | 1,588 | 1,588 | 1,588 | 1,588 | 1,588 | 1,588 | |
| A ¹ – OVERALL WIDTH | 1,349 | 1,349 | 1,349 | 1,349 | 1,591 | 1,591 | 1,591 | 1,591 | 1,591 | 1,591 | 1,591 | |
| B – OVERALL HEIGHT ³ | 1,816 | 1,895 | 1,857 | 1,899 | 1,848 | 1,946 | 1,946 | 1,946 | 2,054 | 2,102 | 2,102 | |
| C – COOLER C/L | 351 | 351 | 351 | 351 | 432 | 432 | 432 | 432 | 432 | 432 | 432 | |
| D – CONDENSER C/L | 295 | 295 | 295 | 295 | 362 | 362 | 362 | 362 | 362 | 362 | 362 | |

All dimensions in mm.

FIG. 6 – OVERALL DIMENSIONS - STANDARD INTERNATIONAL, S0 THRU S3 COMPRESSOR

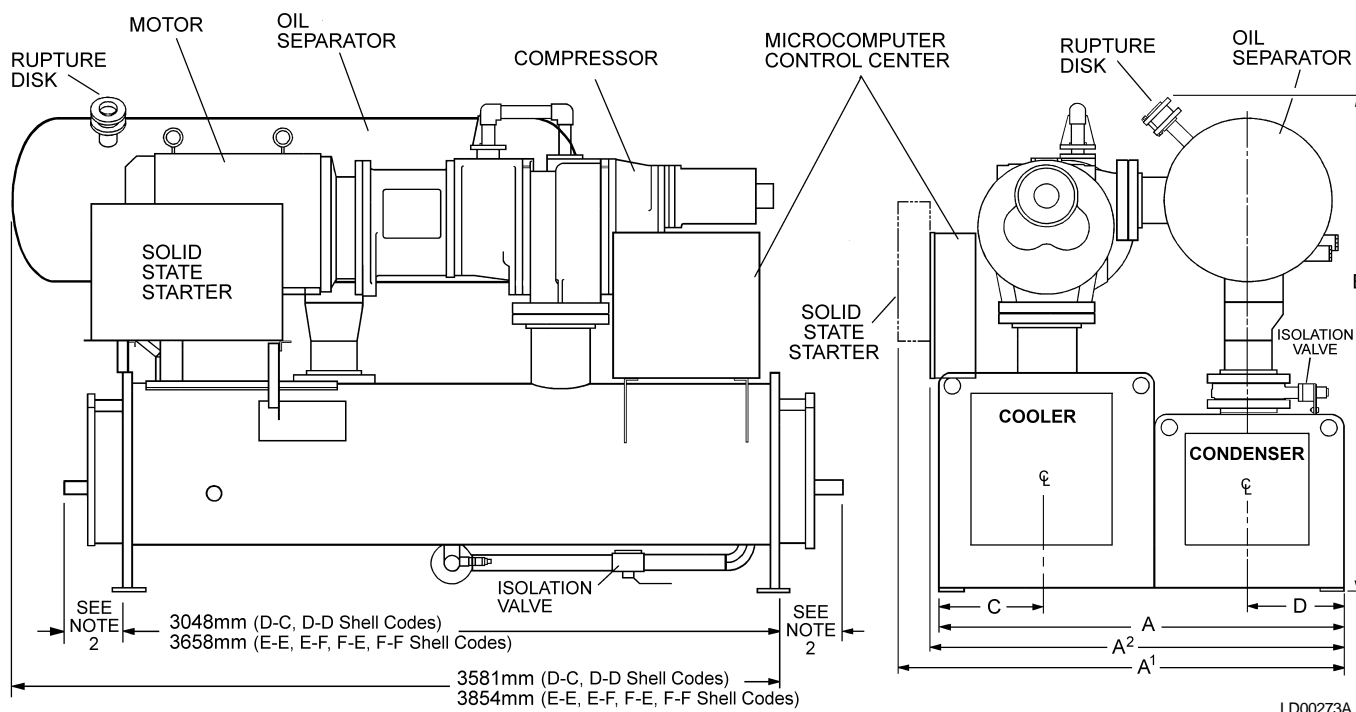

| DIMENSION | S4 COMPRESSOR | | S4 and S5 COMPRESSOR | | | |
|---|----------------------------------|-------|----------------------|-------|-------|-------|
| | SHELL CODES (Cooler – Condenser) | | | | | |
| | D-C | D-D | E-E | E-F | F-E | F-F |
| A – TUBE SHEET WIDTH | 1,880 | 1,880 | 1,880 | 1,943 | 1,994 | 2,057 |
| A ¹ – WITH SOLID STATE STARTER | 2,080 | 2,080 | 2,080 | 2,143 | 2,226 | 2,200 |
| A ² – OVERALL WIDTH (Less S.S.S) | 1,915 | 1,915 | 1,880 | 1,943 | 1,994 | 2,057 |
| B – OVERALL HEIGHT ³ | 2,365 | 2,365 | 2,365 | 2,496 | 2,496 | 2,496 |
| C – COOLER C/L | 502 | 502 | 502 | 502 | 559 | 559 |
| D – CONDENSER C/L | 438 | 438 | 438 | 470 | 438 | 470 |

All dimensions in mm.

FIG. 7 – OVERALL DIMENSIONS - STANDARD INTERNATIONAL, S4 AND S5 COMPRESSOR

INSTALLING OPTIONAL SPRING ISOLATORS

To install these spring isolators, first remove the bolts and nuts from the spring isolator bracket. Bolt the isolator bracket to the unit foot support before the unit is located on the floor. Place the four spring isolators in

position in accordance with the product drawing, Form 160.47-PA1. The threaded adjusting bolts in each isolator should be screwed out of the isolator until the extended head of the screw fits snugly into the isolator bracket hole. Then the unit is lowered over the adjusting bolts. Refer to Figure 8.

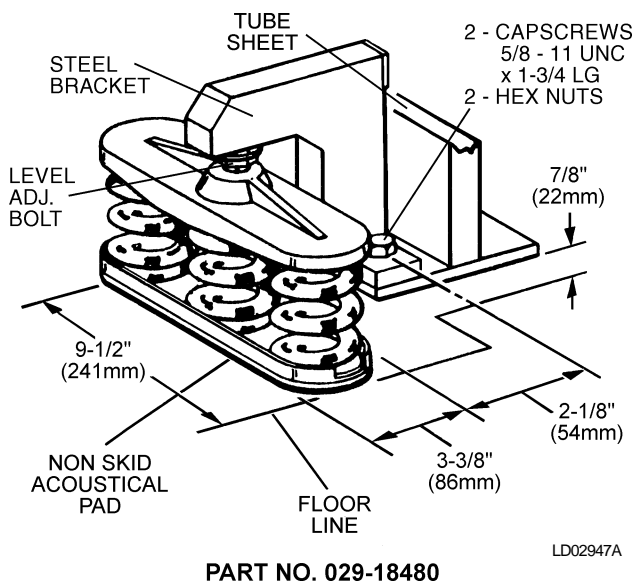
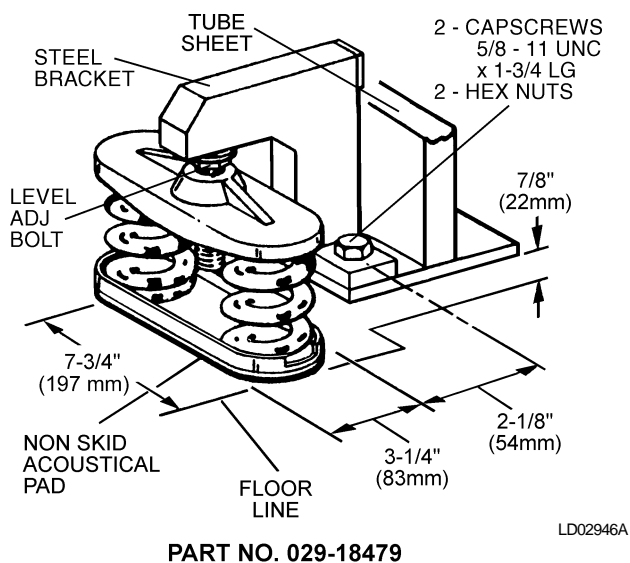

SPRING ISOLATORS (4 Per Unit) – ENGLISH

| COMPRESSOR SIZE | SYSTEM OPERATING WEIGHT (Lbs.) | PART NUMBER |
|---------------------------|--------------------------------|---------------|
| S0, S1, S2, S3 | UP to 6,865 | 029-18479-001 |
| | 6,866 to 9,818 | 029-18479-002 |
| | 9,819 to 12,182 | 029-18479-003 |
| | 12,183 to 15,272 | 029-18479-004 |
| | 15,273 to 18,272 | 029-18480-001 |
| | 18,273 to 22,909 | 029-18480-002 |
| S4, S5 | UP to 22,909 | 029-18480-002 |
| | 22,910 to 26,044 | 029-18480-003 |
| | 26,045 to 32,101 | 029-18480-004 |

SPRING ISOLATORS (4 Per Unit) – SI

| COMPRESSOR SIZE | SYSTEM OPERATING WEIGHT (kg) | PART NUMBER |
|---------------------------|------------------------------|---------------|
| S0, S1, S2, S3 | UP to 3,114 | 029-18479-001 |
| | 3,115 to 4,453 | 029-18479-002 |
| | 4,454 to 5,525 | 029-18479-003 |
| | 5,526 to 6,927 | 029-18479-004 |
| | 6,928 to 8,288 | 029-18480-001 |
| | 8,289 to 10,392 | 029-18480-002 |
| S4, S5 | UP to 10,392 | 029-18480-002 |
| | 10,392 to 11,813 | 029-18480-003 |
| | 11,814 to 14,561 | 029-18480-004 |

FIG. 8 – SPRING ISOLATORS (OPTIONAL)

The adjusting bolts should now be rotated one (1) turn at a time, in sequence, until the unit end sheets are about 7/8 inch (22mm) off the floor or foundation, and the unit is level. Check the level of the unit both longitudinally and transversely. If the adjusting bolts are not long enough to level the unit due to an uneven or sloping floor or foundation, steel shims (grouted, if necessary) must be added beneath the isolator assemblies as necessary.

After the unit is leveled, wedge and shim under each corner to solidly support the unit in this position while piping connections are being made, pipe hangers adjusted and connections checked for alignment. Then the unit can be filled with water and checked for leaks. The adjusting bolts should now be finally adjusted and the wedges and shims can be removed. The unit should now be in correct level position, clear of the floor or foundation and without any effect from the weight of the piping. When the unit is properly supported, spring isolator deflection should be approximately 1" (25 mm).

PIPING CONNECTIONS

After the unit is leveled (and wedged in place for optional spring isolators) the piping connections may be fabricated; chilled water, condenser water and refrigerant relief. The piping should be arranged with offsets for flexibility, and adequately supported and braced independently of the unit to avoid strain on the unit and vibration transmission. Hangers must allow for alignment of pipe. Isolators (by others) in the piping and hangers are highly desirable, and may be required by specifications. This is done to effectively utilize the vibration isolation characteristics of the isolator mounts on the unit.

CHECK FOR PIPING ALIGNMENT

When piping is complete, check for alignment try opening a connection in each line, as close to the unit as possible, by removing the flange bolts or coupling. If any of the bolts are bound in their holes, or if the connection springs are out of alignment. The misalignment must be corrected by properly supporting the piping or by applying heat to anneal the pipe.



It may be necessary to weld chilled water or condenser water piping directly to the water pipe nozzles. Since chilled and condenser water temperature sensor wells are often in close proximity to these connection points, sensors in the wells may often see temperatures of several hundred degrees. We have reason to believe that some potential exists for damaging these sensors from the transferred heat. Any damage will most likely show up as error in the sensor.

It is advisable to remove the sensors from the wells during the welding process as a precautionary measure. If the sensor is removed, assure that it bottoms out when it is placed back in the well.



If the piping is annealed to relieve stress, the inside of the pipe must be cleaned of scale before it is finally bolted in place.

COOLER AND CONDENSER WATER PIPING

YS Chillers have cooler and condenser liquid heads with nozzles that are grooved for the use of victaulic couplings. The nozzles are also suitable for welding Class 150 PSIG (1034 kPa) flanges.

The nozzles and water pass arrangements are furnished in accordance with the job requirements (see Product Drawing, Form 160.47-PA1). Standard units are designed for 150 PSIG (1034 kPa) DWP on the water side. If job requirements are for greater than 150 PSIG (1034 kPa) DWP, check the unit data plate to determine if the unit has provisions for the required DWP before applying pressure to cooler or condenser.

Chilled Water Circuit

The minimum velocity through the tubes is 3 FPS (feet per second) (0.914 MPS - meters per second), so chilled water piping designs for variable flow should be selected with higher velocities at design conditions. The rate of change should be slow, to make sure that the chiller controls can track the load.

The following is a guideline for an allowable variable flow rate of change. This may require modification based on specific design application.

The maximum allowable rate of change is 15 minutes to go from 10% to 50% of design flow, based on a minimum chilled water system turnover rate of 15 minutes. System turnover rate (STR) is a measure of the chilled water system volume as compared to the design chilled water flow rate, and is defined as:

$$\text{System Turnover Rate (STR)} = \frac{\text{Volume of chilled water system (gallons)}}{\text{Design chilled water flow rate (gpm)}}$$

As noted previously, if the STR is above 15 minutes, chilled water flow rate of change is 15 minutes. If STR goes below 15 minutes, chilled water flow rate of change must be modified as follows:

$$\text{Rate of Change from 100\% to 50\% Flow (minutes)} = 15 + 15 - \text{STR}$$

Chilled water must leave the cooler through the connection marked "Liquid Outlet". Cooling water must enter the condenser through the connection marked "Liquid Inlet". Refer to Figure 9.

Foreign objects which could lodge in, or block flow through, the cooler and condenser tubes must be kept out of the water circuit. All water piping must be cleaned or flushed before being connected to the unit, pumps, or other equipment.

Permanent strainers (by others) are required in both the cooler and condenser water circuits to protect the unit as well as the pumps, tower spray nozzles, chilled water coils and controls, etc. The strainer, meeting YORK specifications should be installed in the entering chilled water line, directly upstream of the unit.

Water piping circuits should be arranged so that the pumps discharge through the unit. The circuits should be controlled as necessary to maintain essentially constant chilled and condenser water flows through the unit at all load conditions.

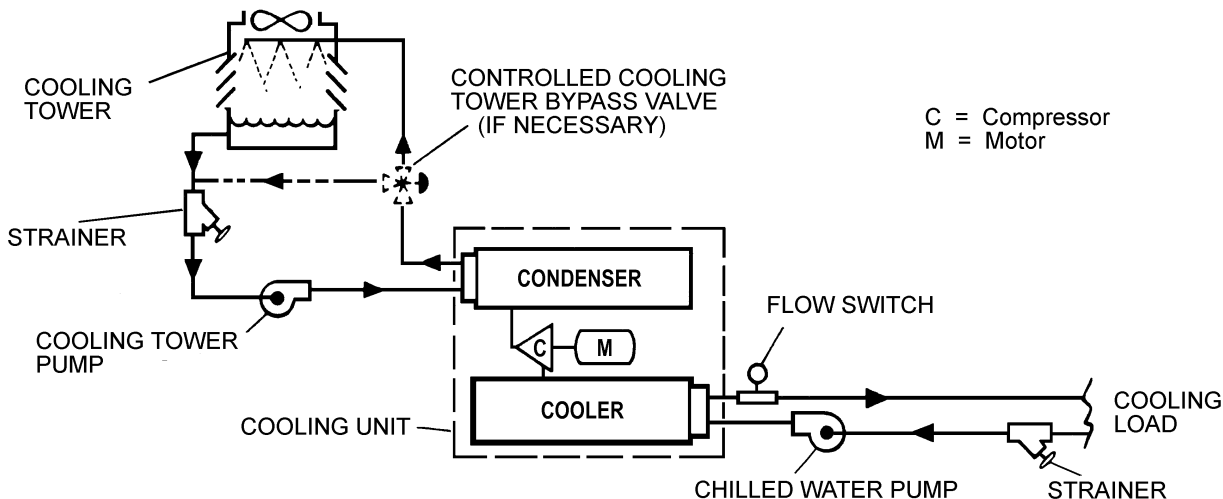

FIG. 9 – SCHEMATIC OF A TYPICAL PIPING ARRANGEMENT

LD03299

If pumps discharge through the unit, the strainer may be located upstream from the pumps to protect both pump and unit. (Piping between the strainer, pump and unit must be very carefully cleaned before start-up.) If pumps are remotely installed from the unit, strainers should be located directly upstream.

Condenser Water Circuit

For proper operation of the unit, condenser refrigerant pressure must be maintained above cooler pressure. If operating conditions will fulfill this requirement, no attempt should be made to control condenser water temperature by means of automatic valves, cycling of the cooling tower fan or other means. Refer to Fig. 9 for a typical water piping schematic. YS units are designed to function satisfactorily and efficiently, when condenser water is allowed to seek its own temperature level at reduced loads and off-peak seasons of the year. However, if entering condenser water temperature can go below the required minimum, condenser water temperature must be maintained equal to or slightly higher than the required minimum. Refer to page 37, Condensing Water Temperature, and the formula to calculate the minimum Entering Condensing Water Temperature.

Stop Valves

Stop valves may be provided (by others) in the cooler and condenser water piping, adjacent to the unit to ease maintenance. Pressure taps should be provided (by others) in the piping as close to the unit as possible, to aid in obtaining operating checks.

Flow Switches (Field Installed)

A flow switch or pressure differential control in the chilled water line(s), adjacent to the unit, is an accessory which can be provided by YORK for connection to the control center. If a flow switch is used, it must be directly in series with the unit and sensing only water flow through the unit. The differential switch must sense pressure drop across the unit.

Drain and Vent Valves

Drain and vent valves (by others) should be installed in the connections provided in the cooler and condenser liquid heads. These connections may be piped to drain if desired.

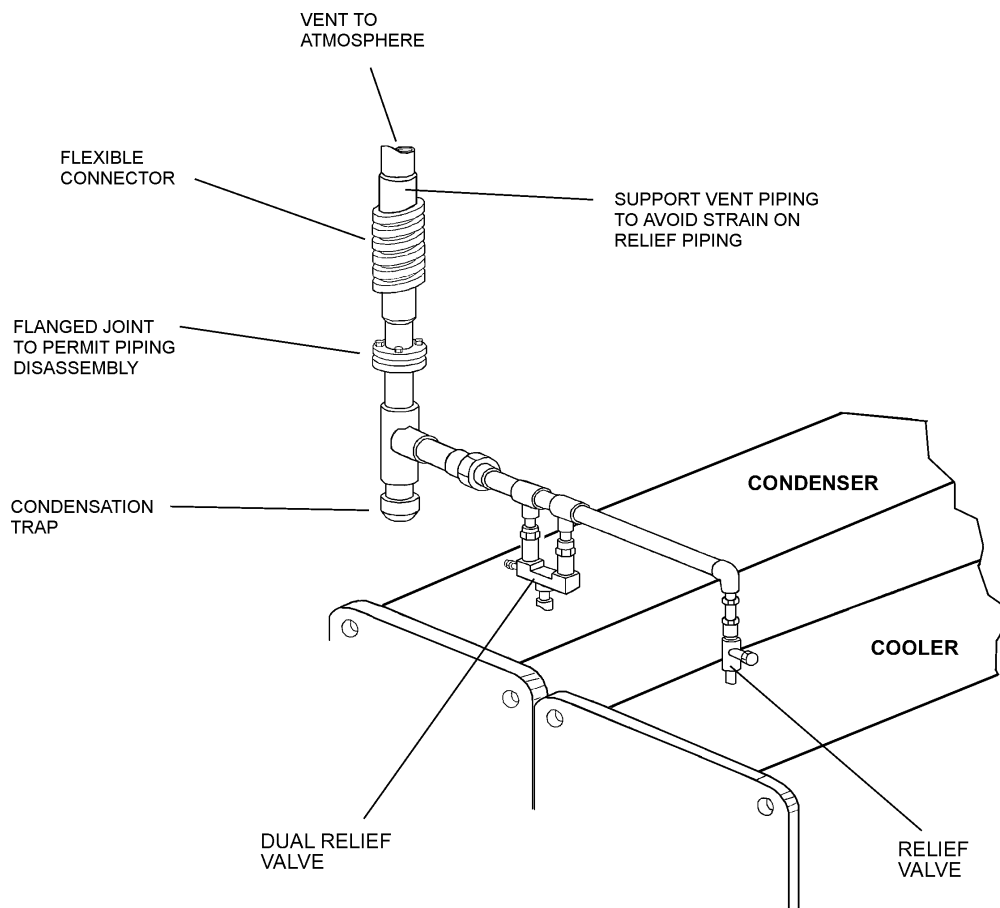

FIG. 10 – TYPICAL REFRIGERANT VENT PIPING FROM RELIEF VALVES

Checking Piping Circuits and Venting Air

After the water piping is completed, but before any water box insulation is applied, tighten and torque the nuts on the liquid head flanges (to maintain between 30 and 60 ft. lbs. / 41 and 81 nm). Gasket shrinkage and handling during transit cause nuts to loosen. If water pressure is applied before this is done, the gaskets may be damaged and have to be replaced. Fill the chilled and condenser water circuits, operate the pumps manually and carefully check the cooler and condenser water heads and piping for leaks. Repair leaks as necessary.

Before initial operation of the unit both water circuits should be thoroughly vented of all air at the high points.

REFRIGERANT RELIEF PIPING

Each unit is equipped with relief device(s) on the cooler, condenser and oil separator for the purpose of quickly relieving excess pressure of the refrigerant charge to the atmosphere in case of an emergency. The relief

valve is furnished in accordance with American Society of Heating, Refrigeration and Air Conditioning Engineers Standard 15 (ASHRAE 15) and set to relieve at 300 PSIG (2069 kPa). The rupture disk on the oil separator is set at 345 PSIG (2379 kPa) and sized to accommodate the compressor pumping capacity. The relief valve is furnished in accordance with ASHRAE-15 and is set to relieve at 300 PSIG (2060 kPa).

Refrigerant relief vent piping (by others), from the relief valves to the outside of the building, is required by code and should be installed on all units. Refer to Figures 10, 11 and Table 4. For additional information on relief valve discharge line sizing, refer to Form 160.47-AD2 (Application Data).

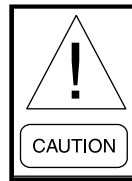

- 1. Piping should be properly supported to prevent any strain on bursting disk mounting.**
- 2. Be careful not to puncture bursting disk when thread protector is removed.**

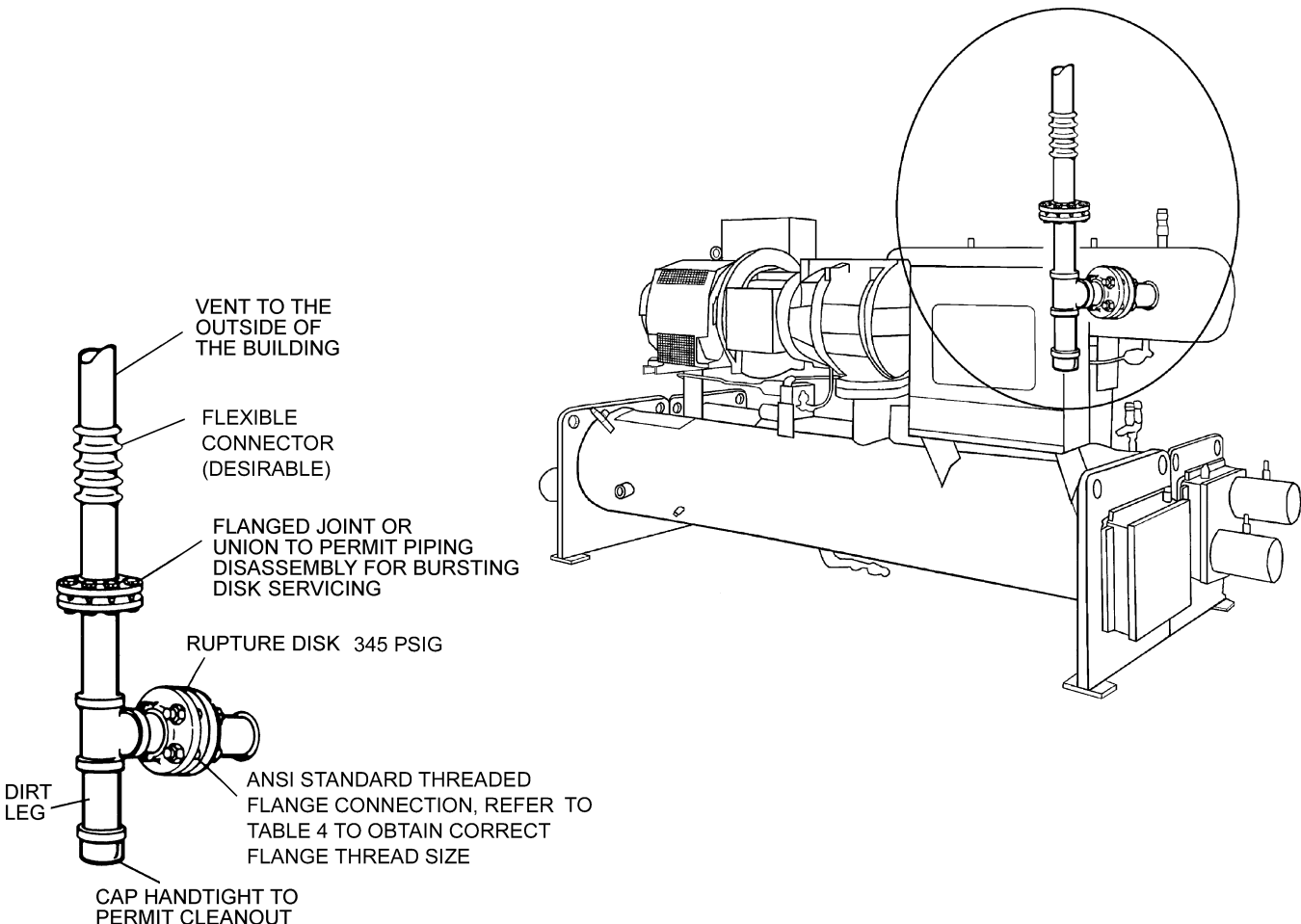

FIG. 11 – TYPICAL REFRIGERANT VENT PIPING FROM RUPTURE DISK

LD03300

TABLE 4 – REFRIGERANT RELIEF CHARACTERISTICS

| OIL SEPARATOR (R-22) | | | | | |
|----------------------|-------------------|------------|-----------|--------------|--------|
| COMPRESSOR CODE | RELIEF VALVE | | | RUPTURE DISK | |
| | C | Cr | DUAL (1) | CR | SINGLE |
| | LBS. AIR PER MIN. | OUTLET NPT | #AIR/MIN. | OUTLET NPT | |
| S0, S1 (2) | 24.0 | 35.9 | *3/4" | 511.0 | 2" |
| S2, S3 (2) | 28.3 | 35.9 | 3/4" | 764.0 | 2" |
| S4 (2) | 33.3 | 63.8 | 1" | 1008.0 | 2-1/2" |
| S5 (2) | 33.3 | 63.8 | 1" | 1275.0 | 2-1/2" |

| OIL SEPARATOR (R-134a) | | | | | |
|------------------------|-------------------|------------|-----------|--------------|--------|
| COMPRESSOR CODE | RELIEF VALVE | | | RUPTURE DISK | |
| | C | Cr | DUAL (1) | CR | SINGLE |
| | LBS. AIR PER MIN. | OUTLET NPT | #AIR/MIN. | OUTLET NPT | |
| S0, S1 (2) | 24.0 | 35.9 | *3/4" | 511.0 | 2" |
| S2, S3 (2) | 28.3 | 35.9 | 3/4" | 511.0 | 2" |
| S4 (2) | 33.3 | 63.8 | 1" | 764.0 | 2-1/2" |
| S5 (2) | 33.3 | 63.8 | 1" | 1008.0 | 2-1/2" |

* Single relief valve

Where:

C = Min. required discharge capacity

Cr = Rated capacity of YORK supplied relief valve @ 300 PSIG or rupture disk at 345 PSIG

Relief valve set pressure - 300 PSIG (2,069 kPa).

Rupture disk set pressure - 345 PSIG (2,379 kPa).

NOTES:

- Dual relief valve consists of one three-way shut off valve and two single relief valves. The valve configuration will not allow both valves to be shut off at the same time, and valves are sized such that each relief valve has sufficient discharge capacity when used alone. This permits safe removal of either relief valve for repair or replacement, while maintaining vessel protection.
- ASHRAE 15-1994 Section 9.8 and Appendix F describes relief requirements for positive displacement compressors. Summarized, the unit must be equipped with a relief device suitable for relieving the entire compressor capacity. YORK YS mod E (S0 - S5 compressor) units utilize a 2" rupture disk venting to atmosphere set at 345 PSIG (Refer to Table 4 for proper connection size).

UNIT PIPING

Compressor lubricant piping and system refrigerant piping are factory installed on all units shipped assembled. On units shipped dismantled, the following piping should be completed under the supervision of the YORK representative; the lubricant piping; system oil return using material furnished. See Form 160.80-N1.

CONTROL WIRING

After installation of the control center on units shipped disassembled, the control wiring must be completed between unit components and control center or solid state starter when used, using the wiring harness furnished.

Field wiring connections for commonly encountered control modifications (by others), if required, are shown on Wiring Diagram, Form 160.47-PW5.

| COOLER | | | |
|--------|---------------------|------|--------|
| SHELL | SINGLE RELIEF VALVE | | |
| | C | Cr | OUTLET |
| | LBS. AIR PER MIN. | | NPT |
| B | 26.3 | 35.9 | 3/4" |
| C | 31.7 | 35.9 | 3/4" |
| D | 39.7 | 63.8 | 1" |
| E | 51.2 | 63.8 | 1" |
| F | 62.4 | 63.8 | 1" |

| CONDENSER | | | |
|-----------|-----------------------|------|--------|
| SHELL | DUAL RELIEF VALVE (1) | | |
| | C | Cr | OUTLET |
| | LBS. AIR PER MIN. | | NPT |
| B | 24.0 | 35.9 | 3/4" |
| C | 28.3 | 35.9 | 3/4" |
| D | 34.3 | 35.9 | 3/4" |
| E | 41.2 | 63.8 | 1" |
| F | 53.6 | 63.8 | 1" |

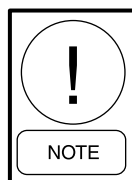

No deviations in unit wiring from that shown on drawings furnished shall be made without prior approval of the YORK Representative.

POWER WIRING

Unit With Electro-Mechanical Starter

A 115 volt – single-phase – 60 or 50 Hertz power supply of 15 amperes must be furnished to the control center, from the control transformer (1-1/2 kVa required) included with the compressor-motor starter. DO NOT make final power connections to control center until approved by YORK Representative. Refer to Form 160.80-PW3, *Power Wiring*. YORK recommends that all connections to the unit be flexible. Consult with and conform to all local regulatory requirements.

POWER WIRING (CONT'D)

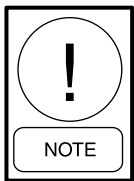

Remote Electro-Mechanical starters for the YS Unit must be furnished in accordance with YORK Standard R-1079.

Each YS unit is furnished for a specific electrical power supply as stamped on the unit data plate, which also details the motor connection diagrams.

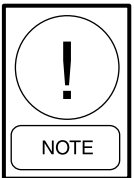

To insure proper motor rotation, the starter power input and starter to motor connections must be checked with a phase sequence indicator in the presence of the YORK Representative.



IMPORTANT: DO NOT cut wires to final length or make final connections to motor terminals or starter power input terminals until approved by the YORK Representative.

Figure 12 shows the power wiring hook-up for YS Motor Connections. (Refer to Wiring Labels in Motor Terminal Box for hook-up to suit motor voltage and amperage.)

Motor leads are furnished with a crimp-type connection having a clearance hole for a 3/8 inch bolt, motor terminal lugs are not furnished.

Unit With Solid State Starter (Optional)

A YS unit equipped with a Solid State Starter, does not require wiring to the compressor-motor. The motor power wiring is factory connected to the Solid State Starter (or an optional factory installed disconnect

switch). All wiring to the control panel is completed by the factory. A control transformer is furnished with the Solid State Starter. Refer to Form 160.80-PW1.

INSULATION

Insulation of the type specified for the job, or minimum thickness to prevent sweating of 30°F surfaces (water chill application), should be furnished (by others) and applied to the cooler shell, end sheets, liquid feed line to flow chamber, compressor suction connection, and cooler liquid heads and connections. The liquid head flange insulation must be removable to allow head removal for tube maintenance. Details of areas to be insulated are given in Product Drawing, Form 160.47-PA1.

Units can be furnished, factory anti-sweat insulated, on order at additional cost. This includes all low temperature surfaces except the two cooler liquid heads.



IMPORTANT: DO NOT field insulate until the unit has been leak tested under the supervision of the YORK Representative.

INSTALLATION CHECK – REQUEST FOR START-UP SERVICE

After the unit is installed, piped and wired as described in this Instruction, but before any attempt is made to start the unit, the YORK District Office should be advised so that the start-up service, included in the contract price, can be scheduled. Notification to the YORK Office should be by means of Installation Check List and Request, Form 160.47-CL1, in triplicate. (See Figure 13.)

The services of a YORK Representative will be furnished to check the installation and supervise the initial start-up and operation on all YS units installed within the Continental United States.

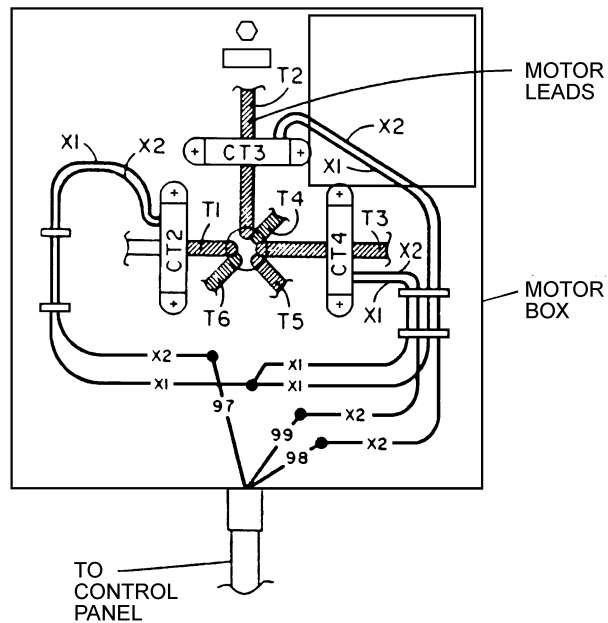

LOW VOLTAGE (6 LEAD MOTOR)
(200V – 600V)

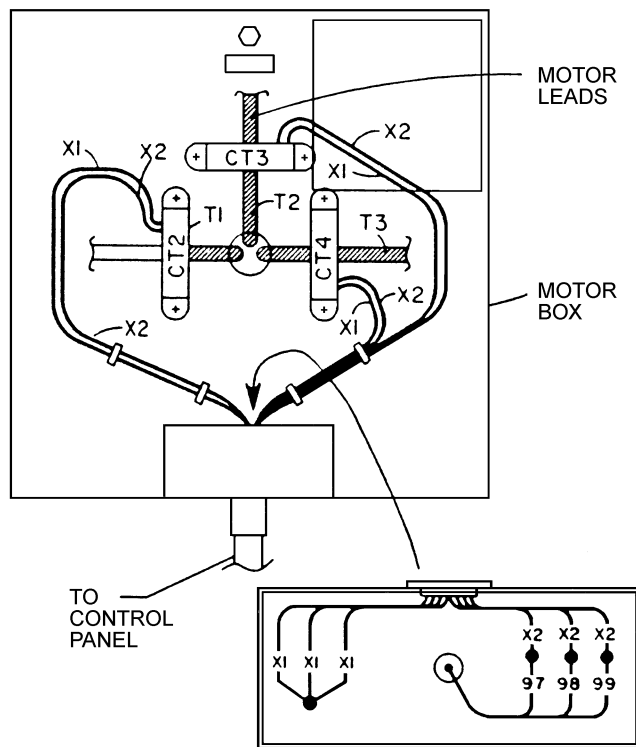

HIGH VOLTAGE (3 LEAD MOTOR)
(2300V – 4160V)

LD03301

FIG. 12 – YS MOTOR CONNECTIONS (ELECTRO-MECHANICAL STARTER APPLICATION)

MODEL YS YORK MILLENNIUM™

INSTALLATION CHECK LIST AND REQUEST FOR AUTHORIZED START-UP ENGINEER

*TO: _____ **JOB NAME:** _____
 _____ **LOCATION:** _____
 _____ **CUSTOMER ORDER NO.** _____
YORK TEL. NO. _____ **YORK ORDER NO.** _____ **YORK CONTRACT NO.** _____

CHILLER _____
MODEL NO. _____ **SERIAL NO.** _____
 The work (as checked below) is in process and will be completed by _____ / _____ / _____
Month Day Year

The following work must be completed in accordance with installation instructions

A. YORK CHILLER

- 1. Unit assembled (if shipped dismantled) and refrigerant piping installed under YORK Supervision
- 2. Vibration isolator mounts so the unit is level, and isolators equally deflected

B. WATER PIPING

- 1. Condenser water piping installed between condenser, pumps and cooling tower
- 2. Chilled water piping installed between cooler, pumps and cooling coils
- 3. Make-up and fill lines installed to cooling tower and chilled water system
- 4. All water piping checked for strain—Piping should not spring when connections are broken at unit
- 5. Water piping leak tested and flushed, and water strainers cleaned after flushing. Piping systems filled with water and trapped air vented
- 6. Chilled and condenser water flow available to meet unit design requirements

C. REFRIGERANT RELIEF PIPING (when required)

- 1. Refrigerant relief piping (with flexible connection) installed from unit to atmosphere (per ASHRAE-15)

D. ELECTRICAL WIRING

- 1. Electro-mechanical starter
 - a. Main and control power supply available
 - b. Compressor motor starter furnished in accordance with YORK Standard R-1079 — Form 160.47-PA5.1
 - c. Wiring completed from main power supply to starter—but not cut to length or connected to starter
 - d. Wiring completed from starter to compressor motor—but not cut to length or connected to motor
 - e. 115 volt service completed to Control Center—but not connected

- 2. Solid state starter
 - a. Main and control power supply available
 - b. Wiring completed from main power supply to solid state starter—but not cut to length or connected to starter...
- 3. Control center
 - a. Jumper wire not installed between terminal 24 and 25 located on the control center terminal strip
 - b. External control wiring completed from the control center to chilled water flow switches on interlocks in accordance with the YORK Wiring Diagram
 - c. Power available and wiring completed to the following starters and motors, and rotation of each checked

NOTE—Do not check compressor motor rotation

 - (1.) Chilled water pump(s)
 - (2.) Condenser water pump(s)
 - (3.) Cooling tower fan
 - d. Meg ohm meter available for checking motor windings

E. TESTING, EVACUATION AND CHARGING (Under York Supervision if Unit Shipped Less Refrigerant or Dismantled)

- 1. R-22 available for testing
- 2. Dry Nitrogen available for testing
- 3. A high vacuum pump available for evacuation and dehydration of system
- 4. Refrigerant-22 (Supplied by YORK available for charging)
- 5. Unit (ready to be) (has been) pressure tested, evacuated, dehydrated and charged

F. CONDITIONS

- 1. YORK oil for compressor on job
- 2. Cooling load available for testing and operating unit
- 3. Personnel available for final wiring connections
- 4. Personnel available for start-up and testing
- 5. Owners operating personnel available for instruction

Names: _____

With reference to the terms of the above contract, we are requesting the presence of your Authorized Representative at the job site on _____ / _____ / _____ to start the system and instruct operating personnel HAVE HIM CONTACT _____ Month

We understand that the services of the YORK Authorized Representative will be furnished in accordance with the contract for a period of not more than _____ consecutive normal working hours, and we agree that a charge of _____ per diem plus travel expenses will be paid to YORK if services are required for longer than _____ consecutive normal hours or if repeated calls are required.

Signed: _____
 Title: _____

FIG. 13 – INSTALLATION CHECK LIST AND REQUEST FOR AUTHORIZED START-UP ENGINEER

SECTION 2 – START-UP

YS CHILLER COMMISSIONING CHECKLIST

This checklist is provided as a guide to the service technician to ensure the YS Chiller is properly commissioned.

- ❖ This symbol indicates that the feature described is programmable or selectable from Graphic Control Center. Refer to Operational Form 160.80-O1 and the Service Manual Form 160.80-M1 for more information concerning the Graphic Control Center. The specific Graphic Control Center screen is listed in bold capital text, followed by the setpoints or operating parameters that can be configured in that screen.
- * An asterisk following one of the Graphic Control Center programmable or selectable features indicates that the default value has been pre-programmed into Graphics Control center at one of the YORK factories.

YS CHILLERS PRE-STARTUP CHECKLIST

Installation

- * Check all utility interconnections to the chiller: water piping, electrical and control wiring to the chiller.
- * Verify that the chiller is level.
- * Check the mounting spring isolators or vibration isolators for equal loading.
- * Check the relief valve piping for excessive load on the relief devices.

Form 2, Form 3 and Form 7 Shipments

- * A Vacuum Dehydration Unit is required for all field re-assembled YS Chillers; Form 3 and Form 7. In addition, Form 2 YS Chillers shipped without refrigerant require a Vacuum Dehydration procedure prior to commissioning. Refer to the Vacuum Dehydration procedure detailed in YORK Form 160.80-N1, *Field Re-Assembly for Form 3 & Form 7 Shipments (Style E)*.

Evaporator and Condenser Flow Rates

- * Check for properly installed and clean strainers in the water supply lines to the evaporator and condenser. Clean and properly installed water strainers is a YORK warranty requirement.

- ❖ Refer to the **Sales Order** screen for the Evaporator and Condenser design flow rates and pressure drops. Use the pressure drops to establish the correct flow rates.

EVAPORATOR SCREEN

Enter the following setpoints:

- ❖ Leaving Chilled Liquid Temperature (except ISN Remote Mode)
- ❖ Remote Leaving Chilled Liquid Temperature Setpoint Range (except ISN Remote mode)
- ❖ Low Chilled Liquid Temperature, Cycling Shutdown Temperature
- ❖ Low Chilled Liquid Temperature, Cycling Shutdown Restart Temperature
- ❖ Leaving Chilled Liquid Temperature Control Sensitivity
- ❖ Brine Low Evaporator Pressure Cutout Threshold*
- ❖ Ice Storage Mode ON/OFF
- ❖ Smart Freeze Protection ON/OFF
- ❖ Refrigerant Temperature Sensor ENABLE/DISABLE

CONDENSER SCREEN

Enter the following setpoints:

- ❖ Enter the High Pressure Limit/Warning Threshold setpoint.
- ❖ Freeze Warning (standby chiller freeze protection) ENABLE/DISABLE
- ❖ Freeze Warning time delay

Flow Safety Devices

- * Locate the flow safety devices and confirm their interconnection to the Graphic Control center.
- * Verify the operation of the flow safety devices. Simulate the low flow condition and make certain the switch is opening under the low flow condition. Removing a wire connection will simulate only the electrical connection, not the functional operation of the flow safety device.

Low Temperature Brine Chillers

- * Verify the freeze point of the brine in the evaporator. Use a hand-held optical refractometer or a hydrometer.
- * Make certain the Brine Low Evaporator Pressure Cutout Threshold* Setpoint (**EVAPORATOR** screen) is set above the brine freeze point.

High Pressure Safety Switch

- * Verify the setpoint of the high-pressure safety switch. Reconfirm the High Pressure Limit/Warning threshold setpoint (**CONDENSER** screen).

Compressor

- * Make certain the incoming electrical power disconnect is in the open position.
- * Remove one of the access cover plates located on the D-Flange Motor-Compressor spacer casting. Check the coupling bolts to make certain they are tight. Check the Allen head set screws in the coupling hubs to make certain they are tightened.
- * Rotate the compressor several revolutions by hand.

COMPRESSOR SCREEN

Maximum Load

- ❖ Maximum Load Temperature
- ❖ Maximum Load FLA
- ❖ Select Minimum Load Control Source (Slide Valve Position or % Motor FLA)
 - ❖ If Motor FLA selected, enter Minimum Load FLA

SLIDE VALVE CALIBRATE SCREEN

- ❖ Perform Slide Valve Calibration

Note the slide valve can be calibrated with the chiller off or while it is running. To perform the slide valve calibration while the chiller is off, it is necessary to use a hand pump to pump oil into the slide valve cylinder to move the slide valve from 0% to 100%. The slide valve can also be calibrated with the chiller running; however, there must be enough available load for the chiller to be loaded to 100% capacity. Refer to Service Manual 160.80-M1, *Graphic Control Center*, for more information.

Motor

- * Check the voltage supply to make certain it is the same as the Motor Nameplate Data.
- * Megohm the motor. Follow the instructions for Motor Megohm Check on page 52.
- * Lubricate the motor bearings. Follow the motor manufacturer instructions.
- * Check motor rotor rotation. All YS Chillers rotate clockwise when viewed facing the compressor shaft.

MOTOR SCREEN

Program the following setpoints:

- ❖ Local Motor Current Limit
- ❖ Pulldown Demand Limit
- ❖ Pulldown Demand Time

Motor Starter

For YORK Solid State Starter, Mod “B”, program the following setpoints:

- ❖ Full Load Amps*
- ❖ Start Current*
- ❖ Supply Voltage Range*
- ❖ Enable Open SCR Detection
- ❖ KWH Reset

For YORK Solid State Starter, Mod “A”, program the following setpoints:

- ❖ Full Load Amps*
- ❖ Supply Voltage Range*
- ❖ Current Unbalance Check ENABLE/DISABLE

Logic Board:

- ❖ Verify location of 300V/600V Jumper*
- ❖ Verify Start Current Calibration*
- ❖ Verify 105% FLA Calibration

For YORK Electro-Mechanical Starter Applications:

Current Module:

- ❖ Verify Switch S1 (Wye-Delta 57% or all others) Setting
- ❖ Verify Pot R16 (LRA/FLA ratio) Setting*
- ❖ Verify Slide Bar Resistor “RES” Setting*
- ❖ Verify 105% FLA Calibration*
- ❖ Verify 100% FLA Calibration*

Refrigerant Leak Check

- ✱ Thoroughly leak check the entire chiller for leaks prior to starting. Make certain to include relief valves. This may require removing field-installed relief valve piping.

Compressor Oil

- ✱ Check the compressor oil level. Oil should be visible in the top sight glass on the side of the oil separator.
- ✱ Make certain that the oil heater has been energized at least 24 hours prior to starting the chiller. Oil temperature should be at least 15°F above saturated refrigerant temperature.

OIL SEPARATOR SCREEN

Enter the following setpoints:

- ❖ Auto Zero ENABLE/DISABLE
- ❖ Seal Oil Pressure Transducer ENABLE/DISABLE

Cooling Tower

- ✱ Verify that the cooling tower is operational and the fans and controls are ready for the chiller to be started.

Water Treatment

- ✱ Make certain the water treatment is in place and operational.

Wiring

- ✱ Check and verify all interconnecting wiring with the wiring diagram.
- ✱ Make certain all wire terminals are tight and plugs are properly secured.

GRAPHIC CONTROL CENTER PROGRAMMABLE FUNCTIONS

PROGRAM JUMPERS / SWITCHES

- ❖ Verify Micro Board Program Jumpers and Program Switches are configured appropriately.

VARIABLE ORIFICE CONTROL SCREEN

- ❖ Enter the Delta P setpoint.

HOT GAS BYPASS SCREEN

If the chiller is equipped with optional Hot Gas Bypass control, enable operation on the **OPERATIONS** screen and enter the following setpoints:

- ❖ ON Setpoint
- ❖ OFF Setpoint

SETPOINTS SCREEN

The setpoints listed on the **SETPOINTS** screen have already been programmed on previous screens. The values shown reflect the previously programmed values. However, the setpoints listed here can be changed on this screen if desired. This screen is used primarily as a central location from which most setpoints can be programmed. If it is not desired to change any of the listed setpoints, proceed to the **SETUP** screen.

SETUP SCREEN

- ❖ Enable Clock
- ❖ Enter Clock Time and Date
- ❖ Select 12 or 24 hour display mode
- ❖ The states of Program Jumpers/Switches that affect Chiller Operation are shown on the **SETUP** screen. These were configured in set 1, above. Refer to Tables 1 and 2 of Service Manual 160.80-M1 if it is desired to change them.

SCHEDULE SCREEN

- ❖ Enable or Disable Daily Start/Stop schedule as required
- ❖ Enter chiller START/STOP schedule, if required.

USER SCREEN

- ❖ Select desired Display Language
- ❖ Select desired Display units; English or Metric
- ❖ If desired, establish custom User IDs and Passwords.

COMMS SCREEN

If Modem or Printer is connected to the Micro Board Serial Data Ports, enter the following parameters as required for each device connected:

- ❖ Baud Rate
- ❖ Number of Data Bits
- ❖ Number of Stop Bits
- ❖ Parity

Enter appropriate number for Modem, Printer or ISN Remote Application:

- ❖ Chiller ID (identification)

PRINTER SCREEN

If printer is connected to Micro Board Serial Ports, enter the following:

- ❖ Automatic Print Logging ENABLE/DISABLE
- ❖ Automatic Printer Logging Start Time
- ❖ Automatic Print Logging Interval
- ❖ Printer Type
- ❖ Report Type (Status, Setpoints, Schedule or Sales Order)

SALES ORDER SCREEN

- ❖ Enter Chiller commissioning date
- IMPORTANT: Print a copy of the Sales Order screen and maintain a copy on file in the local YORK Service Office.**

OPERATIONS SCREEN

- ❖ Select desired Control Source (Operating Mode); Local, ISN Remote, Digital Remote, or Analog Remote
- ❖ Hot Gas Bypass Control (optional) ENABLE/DISABLE

The following can be changed if desired:

- ❖ Chiller Start Counter
- ❖ Chiller Operating Hours Counter

YS CHILLER START-UP

Start

- * Start the chiller and operate the chiller at design conditions or at the maximum load conditions available.

Graphic Control Center

- * Recheck the setpoints and programmable functions of the Graphic Control Center. Change as necessary to match the operating conditions.

Print

- * Use the Graphic Control Center print feature to print a copy of all operating data.
- * Print a copy of the Sales Order Screen.

Important: Save the hard copies of the operating data and the Sales Order screen. Maintain a file in the local YORK Service Office.

Leak Check

- * Thoroughly check all fittings and connections for oil and refrigerant leaks.

CUSTOMER (OPERATING PERSONNEL) INSTRUCTION

Operation

- * Instruct the customer or operating personnel on the location of all controls and the operation of the Graphic Control Center.

Maintenance

- * Review the maintenance schedule with the customer.
- * Review the preventative maintenance schedule with the operating personnel and make certain that it is thoroughly understood, including the required oil filter element change after the first 200 hours of operation.
- * Start-up is an excellent time to log baseline data from vibration analysis, oil analysis and eddy current testing.

SECTION 3 – OPERATION

BASIC DESCRIPTION

The YORK YS Chiller package uses a refrigerant-flooded evaporator and a liquid-cooled condenser. The compressor is a heavy-duty, industrial-rated rotary screw compressor. The YS package consists of four major components - Driveline, Oil Separator, Condenser, and Evaporator. Refer to the Chiller Package Component drawing, Figure 14.

COMPONENTS

Driveline

The driveline is made up of the compressor and a 2-pole industrial induction motor. The motor is mounted to the compressor with a “D”-flange spacer. The “D”-flange eliminates the necessity to align the motor and compressor.

The compressor is a positive displacement, variable volume, direct drive, twin helical rotary screw compressor. The male rotor is a direct drive by the motor; the female rotor is an idler that is driven by the male rotor. The rotors do not touch each other or the compressor housing. The rotors are separated by a hydraulic oil seal, which prevents high pressure gas from leaking into low pressure areas.

Evaporator pressure gas is drawn into the compressor and compressed by the male and female rotors as they rotate together and reduce the volume of gas.

The compressor bearings are industrial duty rated, anti-friction rolling element bearings. No sleeve bearings are used. Oil is injected into the compressor by differential pressure to lubricate the bearings, seal the rotors and remove the heat of compression. The oil that is injected into the compressor mixes with the compressed gas and is separated from the refrigerant gas in the oil separator.

A slide valve is positioned between the male and female rotors, that moves axially to match the compressor capacity to that of the evaporator refrigeration load. The slide valve is moved by differential pressure. As the slide valve moves toward the unloaded position, less suction gas is pumped through the compressor. The control panel automatically positions the slide valve to match the load requirements. The slide valve can be operated manually.

When the compressor is shut off, a spring returns the slide valve to unloaded position. The compressor starts with the slide valve in the unloaded position.

Oil Separator

The oil separator removes the oil that was injected into the compressor. The oil separator is a three stage design. Most of the oil separates by a reduction in velocity in the first stage. The discharge gas is then directed through a high surface area that collects more of the oil. The final stage is a coalescer element(s) that removes the fine aerosol particles of oil.

The oil separator is very efficient and removes nearly 100% of the oil. The very small amount of oil that does pass through the oil separator is returned to the compressor through a filter drier.

The oil separator is also a reservoir for the oil. A temperature controlled immersion heater is installed in the oil reservoir. The oil heater is interlocked with a low oil level safety switch.

Condenser

Oil free refrigerant gas leaving the oil separator flows into the condenser. Water flowing through the condenser tubes removes the evaporator heat load, the heat of compression and condenses the refrigerant gas into refrigerant liquid.

The liquid refrigerant then flows through the integral liquid sub-cooler located in the bottom of the condenser. The sub-cooled liquid refrigerant flows into the evaporator by differential pressure.

Evaporator

Condensing pressure refrigerant flows out of the liquid sub-cooler into the liquid line where the liquid refrigerant is metered into the evaporator by an orifice. The liquid refrigerant begins to flash (and cool) after flowing through the orifice plate. The refrigerant is distributed in the bottom of the evaporator. Liquid refrigerant floods the evaporator and the heat is exchanged from the chilled liquid, flowing on the inside of the evaporator tubes, to the liquid refrigerant on the outside of the tubes.

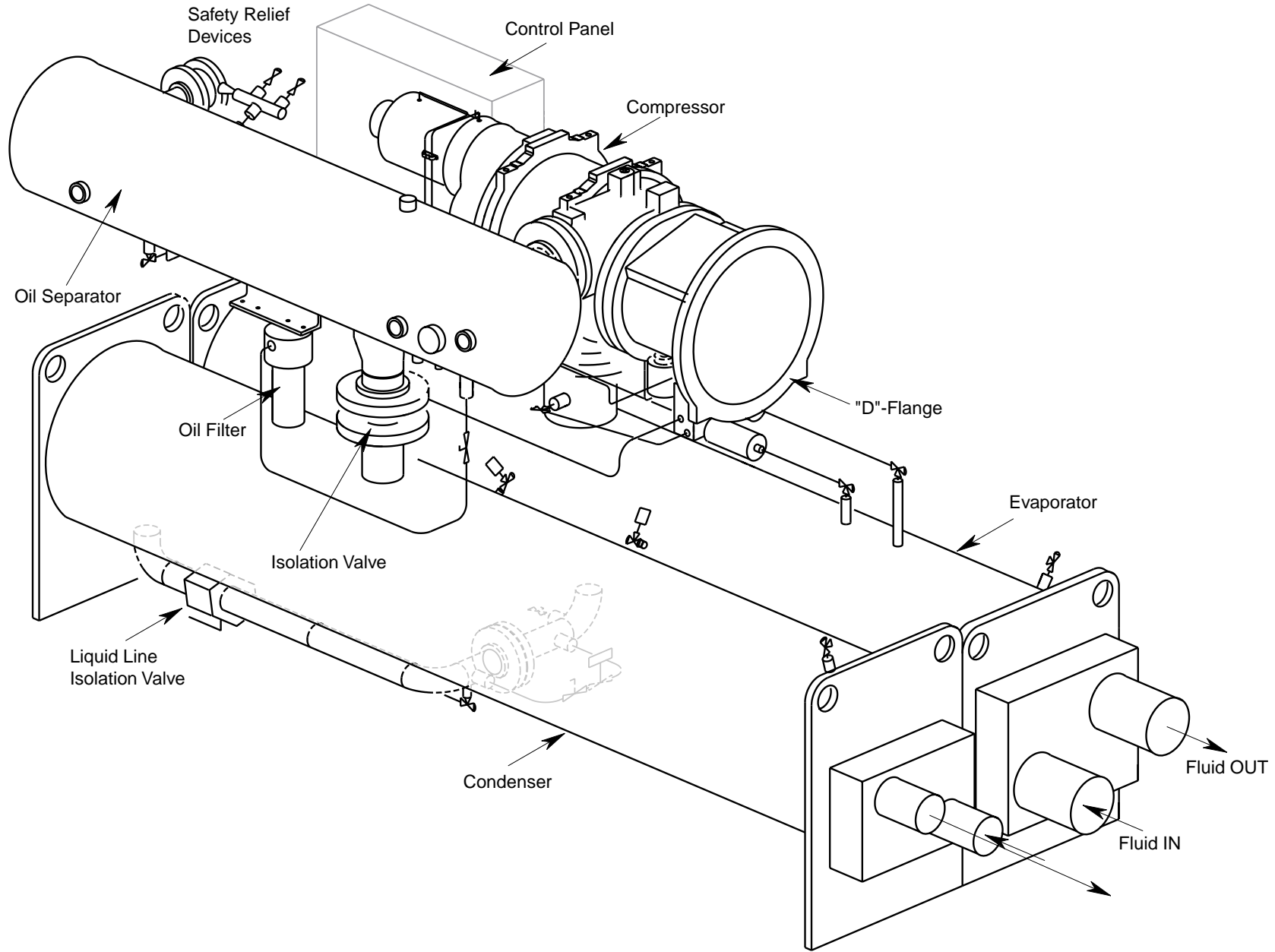

FIG. 14 – YS SCREW CHILLER COMPONENT LAYOUT DRAWING – DESIGN LEVEL "E"

LD004898

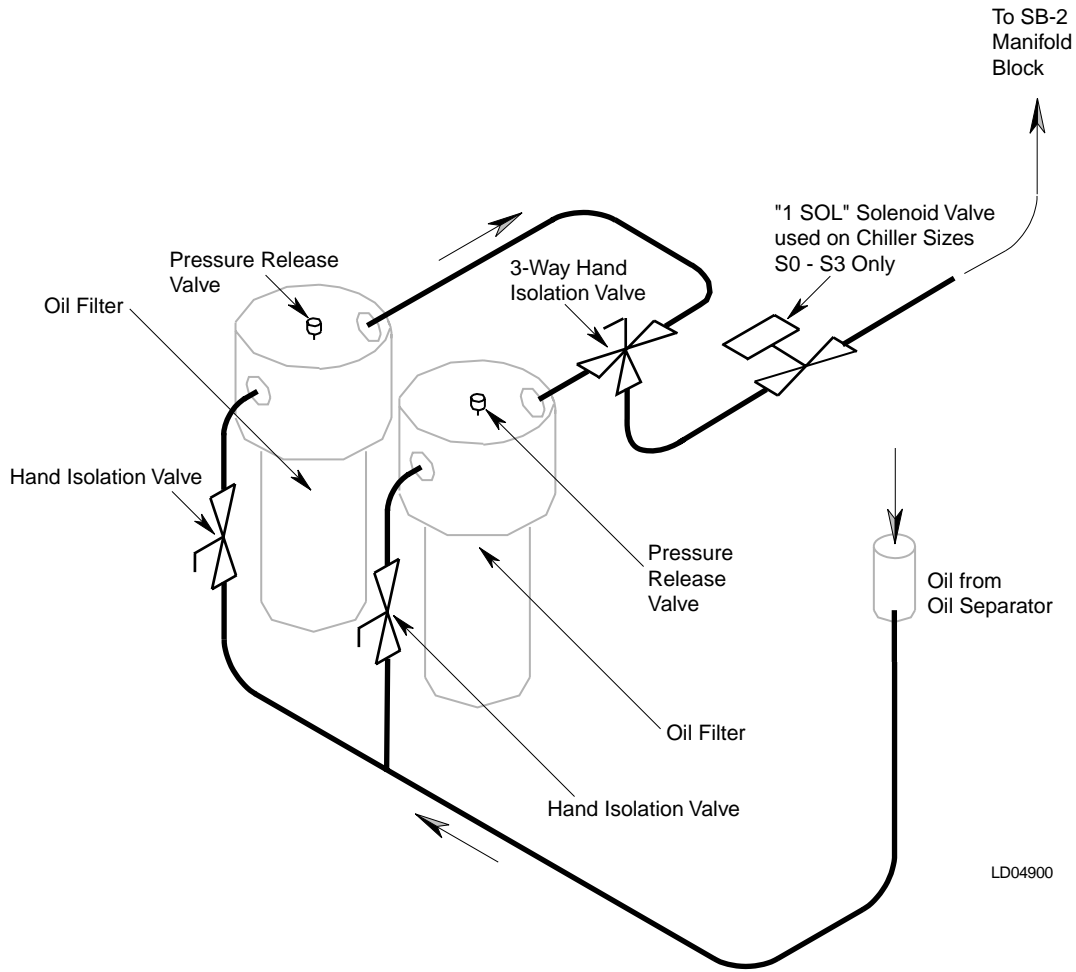

FIG. 16 – YS SCREW CHILLER OPTIONAL DUAL OIL FILTERS PIPING SCHEMATIC – DESIGN LEVEL “E”

A baffle is welded into the top of the evaporator to collect oil that falls from the compressor, preventing oil from mixing with the refrigerant charge. The baffle prevents liquid refrigerant from damaging the compressor.

CONDENSING WATER TEMPERATURE

YS Chillers can be operated with entering condensing water temperature that is less than design conditions. The following formula is used to calculate the minimum entering condensing water temperature. Note the minimum entering condensing water temperature is dependent upon the operating load condition.

R-22 Refrigerant

ECW minimum =

$$LCWT + 11 + \left[\frac{(\% \text{ of load})(15 - \text{design condenser } \Delta T)}{100} \right]$$

R-134a REFRIGERANT

ECW minimum =

$$LCWT + 16 + \left[\frac{(\% \text{ of load})(10 - \text{design condenser } \Delta T)}{100} \right]$$

Where:

ECW minimum =

Minimum Entering Condensing Water Temperature °F

LCWT =

Leaving Chilled Water Temperature °F

Operating below the minimum entering condensing water will not provide energy savings and will result in oil management problems.

Special entering condensing water temperature controls may be required when long condensing water circuits are used and the chiller is being started with minimum load available.

OIL SYSTEM

Refer to the Oil Piping Schematic Drawing, Figure 15 and the Oil Separator Drawing, Figure 20.

Oil flows from the oil separator into the compressor by differential pressure. The oil flows from the oil separator through a 3 micron oil filter (or optional dual oil filters). Filtered oil then flows to a oil manifold that is located at compressor port SB-2, see Figure 15.

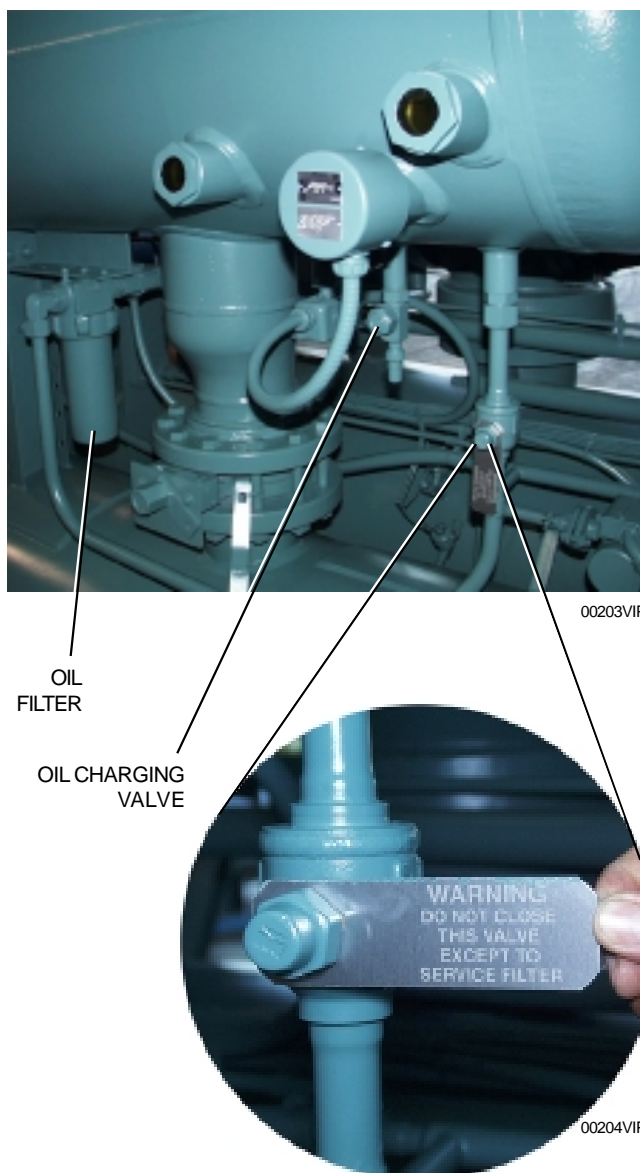

FIG. 17 – OIL FILTER LOCATION

The oil pressure transducer is located at the SB-2 manifold. The differential pressure is measured as the difference between the Oil Pressure Transducer at SB-2 and the Filter Pressure Transducer located in the oil separator. This value is compared to the limits in the control panel logic. If the oil filter differential reaches 20 PSID, a warning message is displayed by the control panel display. If the oil filter reaches 25 PSID, a safety shutdown is initiated. See Figure 18.



FIG. 18 – OIL AND FILTER PRESSURE TRANSDUCERS

An oil supply line from the manifold at SB-2 is piped to the capacity control directional valve at Port P. The 4-way capacity control solenoid (directional) valve directs oil pressure against one side or the other of the slide valve piston. The opposite side of the slide valve is relieved to suction pressure at compressor port SC-11. The differential pressure between the P port and the suction pressure at Compressor Port SC-11 is what provides the force to load or unload the slide valve and provide capacity control. Refer to Fig. 26, Capacity Control Schematic Diagram.

Oil flows from the oil manifold at SB-2 to the brazed plate, refrigerant cooled oil cooler. Cool oil leaving the brazed plate heat exchanger flows to the eductor block manifold. The oil circuit is separate from the eductor oil management system. See Figure 19.

The eductor block manifold oil circuit contains the Seal Oil Pressure Transducer and a High Oil Temperature

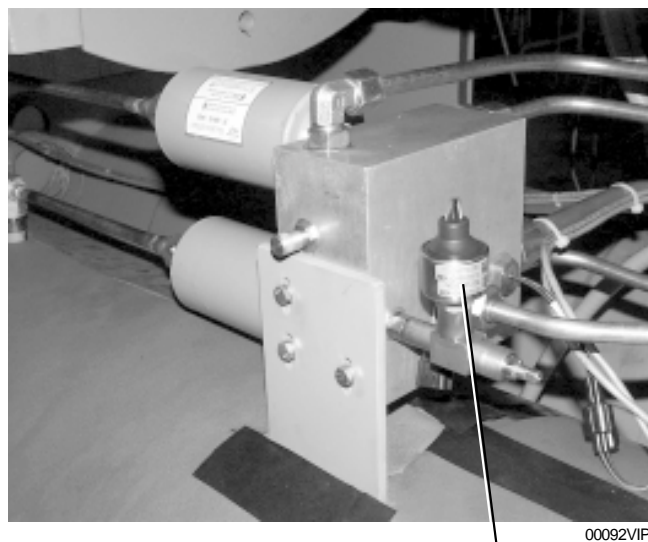

FIG. 19 – EDUCTOR BLOCK

Safety sensor. The Seal Oil Pressure is monitored by the control panel. The differential pressure between the Seal Oil Pressure and the Evaporator Pressure Transducer is calculated and compared to the control panel logic. If the differential reaches the set point (30 PSID for R-22 and 20 PSID for R-134a, the control panel will initiate a safety shutdown. A high oil temperature safety shutdown will be initiated at 170°F (77°C).

The oil leaving the oil eductor manifold block flows into the compressor at compressor port SB-3 to lubricate the compressor bearings and shaft seal. All of the oil that is injected into the compressor mixes with refrigerant gas during compression. The oil and refrigerant gas is discharged into the oil separator, where it is separated and returned to the oil sump. A high discharge temperature safety is located in the discharge line, between the compressor and oil separator. This safety will initiate a safety shutdown at 210°F (99°C).

Oil is separated from the refrigerant gas in the oil separator in a three step process.

In the first stage of oil separation, high velocity oil and refrigerant gas in the compressor discharge line under goes a rapid reduction in velocity as it enters the large diameter oil separator. Most of the oil drops out of the refrigerant gas stream due to the reduction in velocity. The oil falls by gravity into the oil reservoir located in the bottom of the oil separator.

The second stage of oil separation is accomplished by directing the refrigerant gas through mesh pads that have an extended surface area. Smaller liquid oil drop-

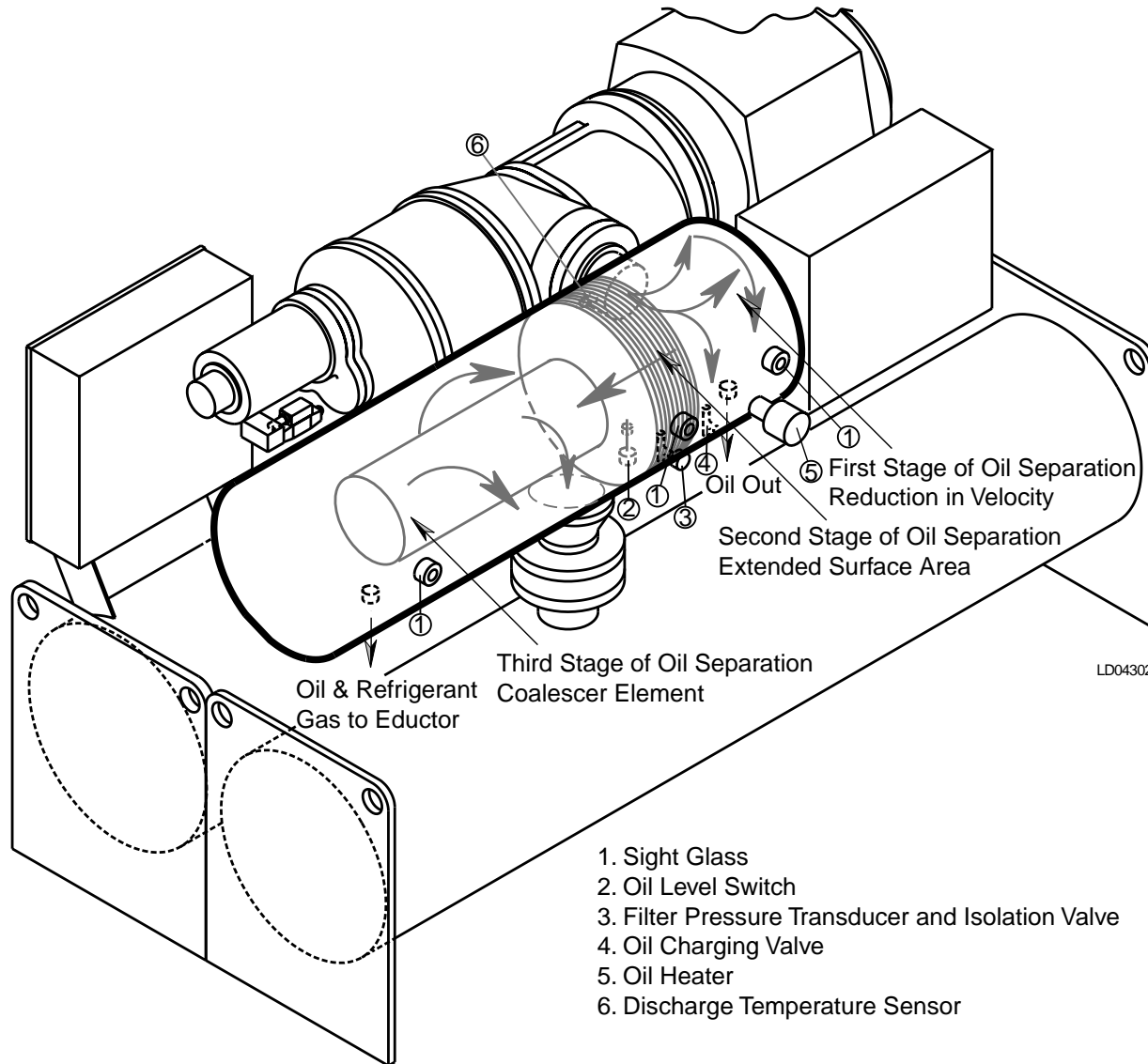

- 1. Sight Glass
- 2. Oil Level Switch
- 3. Filter Pressure Transducer and Isolation Valve
- 4. Oil Charging Valve
- 5. Oil Heater
- 6. Discharge Temperature Sensor

39 **FIG. 20 – YS SCREW CHILLER OIL SEPARATOR SCHEMATIC – DESIGN LEVEL “E”**

lets are collected on the extended surface area of the wire mesh pads where the oil falls by gravity into the oil reservoir.

The third and final stage of oil separation is achieved in the oil coalescing element section of the oil separator. The oil mixed with the refrigerant entering the coalescer element is a very fine aerosol mist about the size of cigarette smoke particles. These small aerosol mist particles wet the coalescer element media and form larger oil droplets which fall by gravity to the bottom of the coalescer element section. The oil collected in the coalescer section is drained from the oil separator with a small amount of refrigerant gas. This provides the high pressure “gas drive” for the eductors to return oil from the evaporator. Refer to section titled “Oil Eductor Circuit”, page 41.

Three sight glasses are provided in the oil separator for monitoring the oil level and verifying performance of the coalescer element. Liquid oil should be visible in the top glass of the oil separator when the chiller is off. During operation, oil may be higher or lower due to system load and operating conditions.

A low oil level safety switch is provided in the bottom of the oil separator. A safety shutdown will be initiated if the oil level is below the switch setting for 30 continuous seconds after the chiller has been running for 3 minutes.

An oil drain and charging valve is located on the bottom of the oil separator. A 5/8 inch male flare connection is provided for ease of connecting a hose to quickly drain used oil into a EPA approved recovery cylinder or tank. Oil can be added into the oil reservoir with the chiller in service.



Do not add oil. YORK YS Chiller packages are pre-charged with the correct amount of YORK oil during functional testing after manufacture. Refer to the Table 6, YORK Oil Types, in the Maintenance Section.

Oil loss is most often the result of operating conditions at loads under 10% of the chillers rated capacity and with condensing water that is too cold for load and operating condition.

The oil is not “lost” but has migrated into the refrigerant charge and is most likely in the evaporator. Excessive amounts of oil in the evaporator will result in operational problems.

Oil management problems result if the compressor discharge superheat is not maintained at the values listed in Table 9. Compressor discharge superheat is the difference between the compressor discharge temperature and the saturated condenser temperature. Compressor discharge superheat is used in conjunction with the evaporator approach to determine the most efficient refrigerant charge.



Should the control panel display EXCESS CHARGE WARNING this is most likely the result of excessive amounts of oil in the evaporator. Excess amounts of oil in the refrigerant will cause foaming. The oil foam carries liquid refrigerant into the compressor. This results in lowering the compressor discharge superheat to low levels. If the compressor discharge superheat falls to within 10°F of the saturated condensing temperature the control panel will display EXCESS CHARGE WARNING. Compressor loading will be inhibited while the EXCESS CHARGE WARNING is displayed. The inhibit loading will remain in effect until the compressor discharge superheat increases to 15°F. Refer to “Oil Recovery Procedure” in the Maintenance section on page 56.

OIL EDUCTOR CIRCUIT

An oil eductor circuit is provided to properly manage the amount of oil in the refrigerant charge. A small amount of oil is normal in the refrigerant charge and will be found in the evaporator. If not properly managed the oil will accumulate and have adverse consequences regarding chiller performance.

The oil eductor circuit consists of three refrigerant and oil filter driers, two “jet pump” eductors and the inter-connecting piping. Refer to Figures 21 and 22.

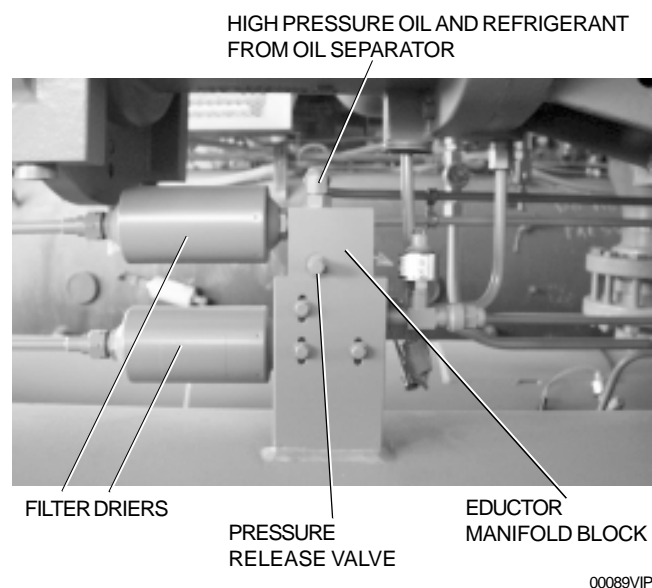

FIG. 21 – FILTER DRIERS AND OIL EDUCTOR

The eductors operate using the “jet pump” principle. Discharge pressure gas and oil flows through a filter dryer located at the bottom of the oil separator. YS Chillers are supplied with a variable orifice arrangement. The reduced pressure (pumping action) is created by the velocity of the discharge pressure gas and oil flowing through the orifice and nozzle. This creates a reduced pressure area that allows the oil-rich refrigerant and oil to flow from the evaporator into the compressor.

Oil-rich refrigerant flows into the eductor block through the filter drier from the evaporator. The oil rich refrigerant mixes with the discharge pressure gas and flows into the compressor suction line.

A second eductor flows oil, which may have collected in the evaporator trough through the second filter drier located on the eductor block. This oil mixes with the discharge gas in the eductor block and flows to the compressor at port SC-5.

The filter driers should be changed annually or when excessive amount of oil is indicated in the refrigerant charge.

LIQUID REFRIGERANT CIRCUIT

Liquid refrigerant flows from the condenser into the evaporator by differential pressure. Sub-cooled liquid refrigerant flows out of the condenser into the liquid line. A metering orifice is installed in the liquid line to control the rate liquid refrigerant flows into the evaporator. The orifice is selected based upon the operating conditions of the chiller. Refer to Figure 23.

YS Chillers are supplied with a variable orifice arrangement. In parallel with the metering orifice is a solenoid valve and hand-throttling valve. The solenoid is energized open by the DIFFERENTIAL PRESSURE set point that is field programmable from the panel. The differential pressure between condensing pressure and evaporating pressure is compared to the set point value. When the differential pressure is at or less than the setpoint, the solenoid valve is energized open. The solenoid valve is de-energized closed when the differential pressure is equal to or greater than the setpoint plus 10 PSIG. A hand-throttling valve is provided to adjust the refrigerant flow rate through the solenoid valve to match the system operating conditions.

Dual Service Chillers – Ice duty and comfort cooling air conditioning applications will require the solenoid valve to be energized open in the air conditioning mode of operation since this represents the low differential pressure mode of operation.

The differential pressure setpoint is field programmable within the ranges specified in Table 5 for different refrigerants and EPROM version S.01F.17 and later. See YORK Service Bulletin 160.47-M2 (SB18) for programming instructions.

TABLE 5 – VARIABLE ORIFICE PRESSURE DIFFERENTIAL SETPOINTS

| REFRIGERANT | DIFFERENTIAL PRESSURE RANGE |
|-------------|-----------------------------|
| R-22 | 25 - 150 PSID |
| R-134A | 15 - 110 PSID |

A liquid line hand-isolation valve is located between the condenser and the metering orifice plate. This valve, in combination with the hand isolation valve between the

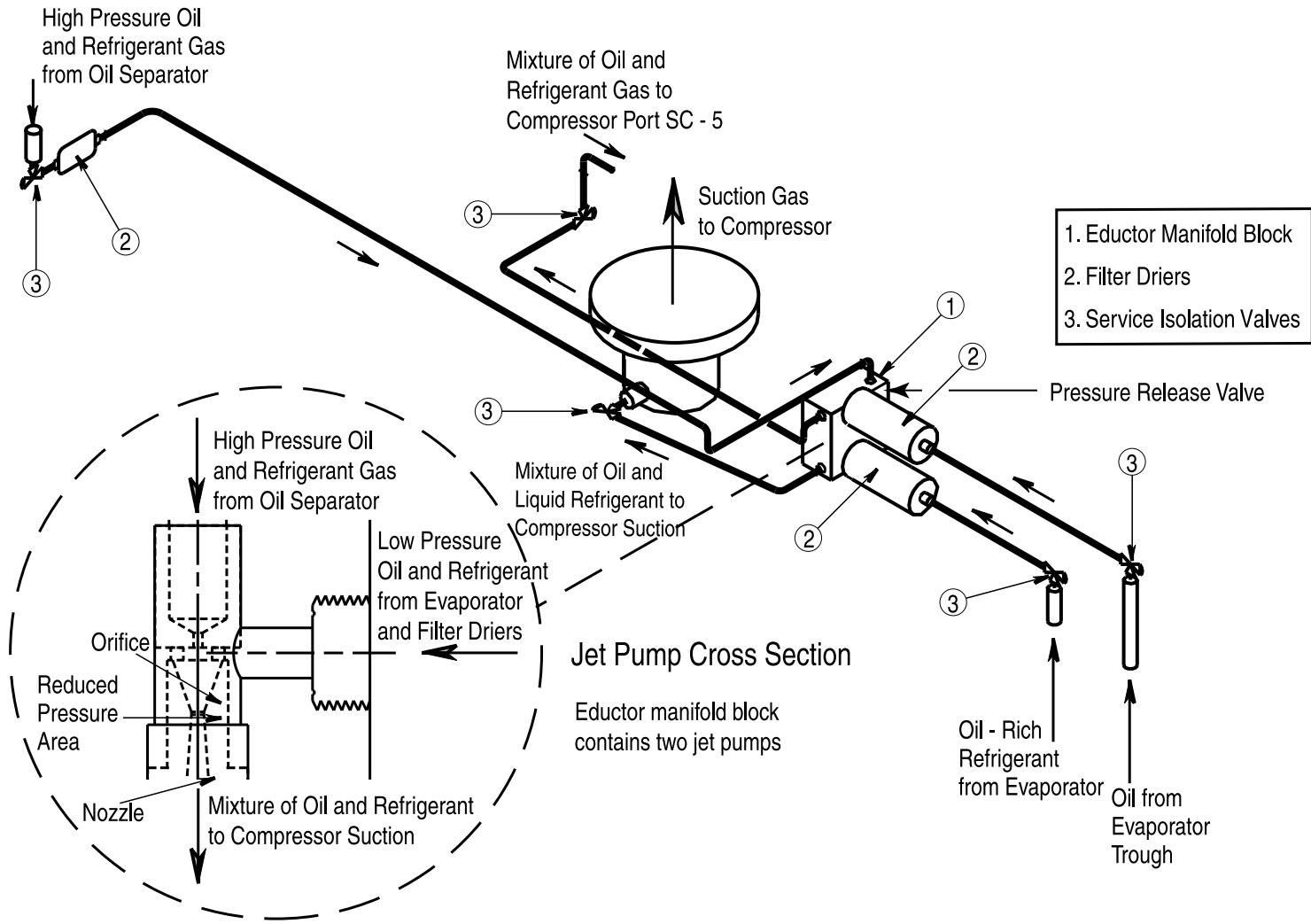

LD04299

FIG. 22 – YS SCREW CHILLER OIL EDUCTOR SCHEMATIC – DESIGN LEVEL “E”

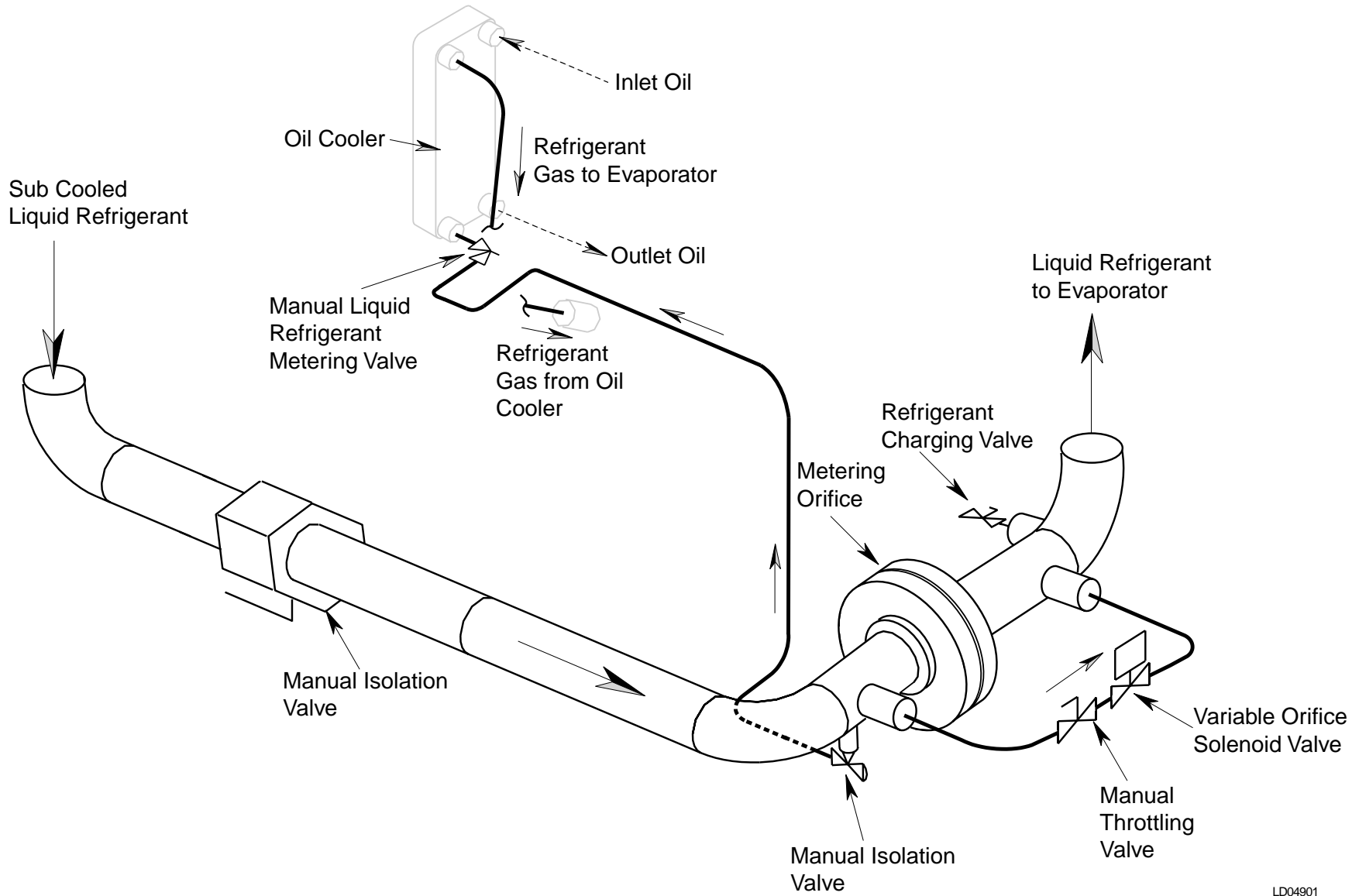

LD04901

FIG. 23 – YS SCREW CHILLER REFRIGERANT SCHEMATIC – DESIGN LEVEL “E”

oil separator and the condenser, allows all of the refrigerant charge to be stored in the condenser.

A ½ inch liquid refrigerant supply is piped from the bottom of the liquid line to the refrigerant cooled oil cooler. The refrigerant gas from the oil cooler is piped directly into the evaporator.

A liquid refrigerant-charging valve is piped into the liquid line between the evaporator and the metering orifice. A ¾ inch male flare connection is provided for connecting hoses or transfer lines.

CAPACITY CONTROL

Refer to the Capacity Control Piping Schematic piping, Fig. 26.

Capacity control is accomplished by using differential pressure to move the slide valve. As the slide valve is moved axially between the compressor rotors the volume of gas pumped by the compressor is changed to match the system requirements.

Leaving evaporator fluid temperature is continuously monitored by the microprocessor. The Leaving Evaporator fluid temperature is compared to the Leaving Evaporator fluid Set Point. When the leaving evaporator fluid temperature is beyond the range of the set point value a signal is sent to the relay output board. A signal is sent from the relay output board to energize the 4-way valve directional solenoid valves.

When Solenoid Valve B is energized the slide valve begins to move in the load direction. The 4-way directional valve opens Port P to Port B and Port A to Port T. Oil pressure from the oil circuit flows into the 4-way solenoid valve sub-plate manifold at Port P. Oil pressure flows through the sub-plate manifold block and out Port B to Compressor Port SC-2. Simultaneously, oil flows out of Compressor Port SC-1 into Port A on the sub-plate manifold, through the sub-plate manifold block and out of the sub-plate manifold block at Port T to suction pressure.

When the Solenoid Valve A is energized, the slide valve will move in the unload direction. The 4-way directional valve opens Port P to Port A and Port B to Port T. See Figure 24. High pressure oil flows into Compressor Port SC-1 and oil is relieved out of Compressor Port SC-2 to suction pressure.

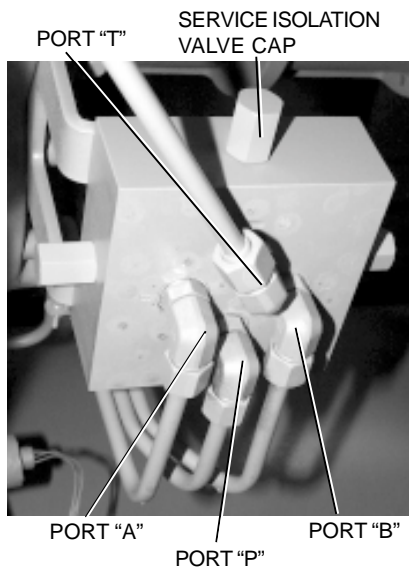

00093VIP

FIG. 24 – 4-WAY DIRECTIONAL VALVE SUBPLATE

A slide valve potentiometer is used to provide feedback to the microprocessor to display slide valve position as a percentage of full load. See Fig. 25.

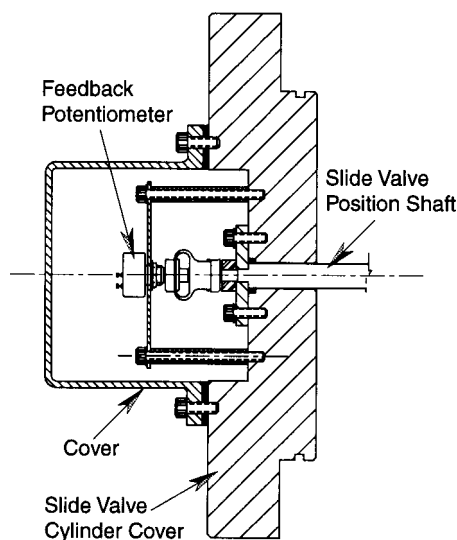

LD05117

FIG. 25 – SLIDE VALVE POTENTIOMETER

Four manual isolation valves are incorporated into the 4-way solenoid sub-plate to isolate the 4-way directional valve for service. Remove the steel hexagonal caps to gain access to the service valve stem. Use a refrigeration service valve wrench to close or open the valves.

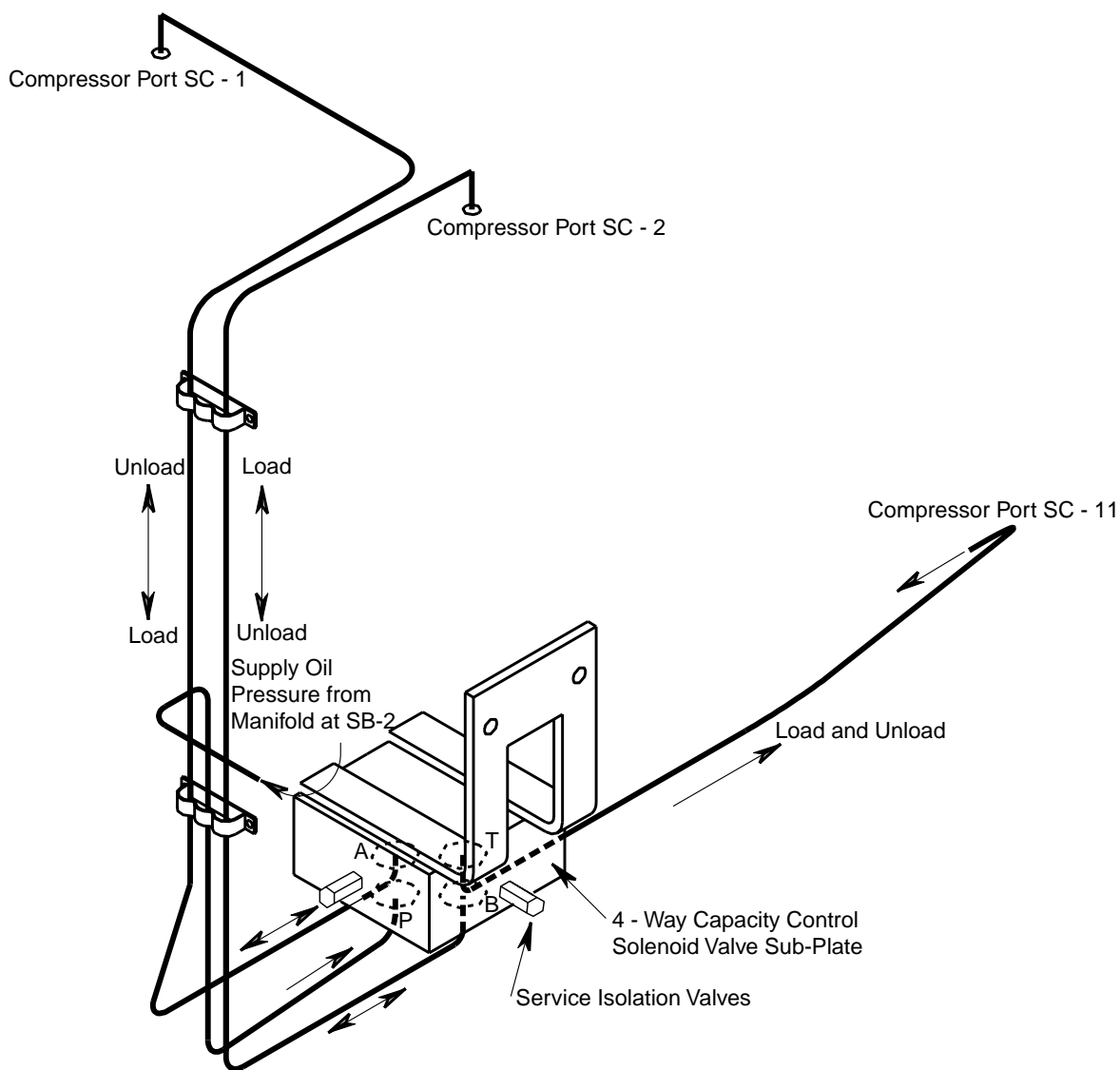

LD04300

FIG. 26 – YS SCREW CHILLER CAPACITY CONTROL PIPING SCHEMATIC – DESIGN LEVEL “E”

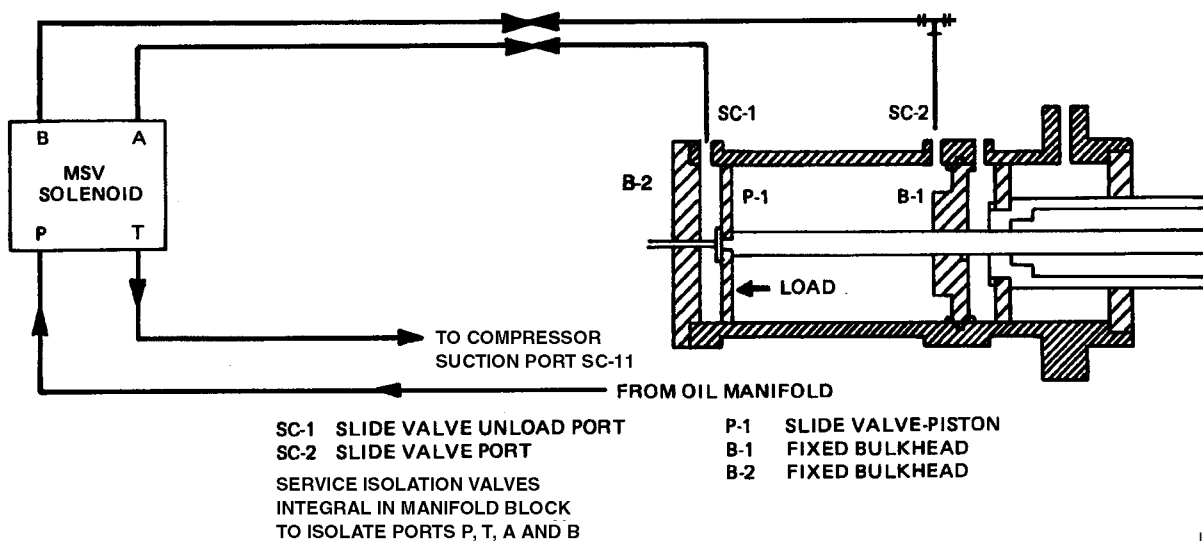

LD04902

FIG. 27 – DOUBLE PURPOSE HYDRAULIC CYLINDER

SECTION 4 – MAINTENANCE

GENERAL

The maintenance requirements for YS Chillers is shown on the following page. The procedure is given in the left- hand column and the frequency required is marked with an “X” shown in the right-hand columns. Refer to the note at the bottom of the form to maintain warranty validation.

COMPRESSOR OIL

YORK oil types approved for YS Chillers and the quantity of oil required is listed in Table 6.

TABLE 6 – YORK OIL TYPES

| CHILLER SIZE | R-22 OIL TYPE | R-134a OIL TYPE | SYSTEM QUANTITY (GAL) |
|--------------|---------------|-----------------|-----------------------|
| S0 | C | H | 10 |
| S1 | C | H | 10 |
| S2 | C | H | 10 |
| S3 | S | H | 10 |
| S4 | S | H | 15 |
| S5 | S | H | 15 |

YORK “C” Oil is a mineral oil. YORK “P” and “H” oil are polyolester (POE) oils. Polyolester oil is very hygroscopic and will absorb moisture from the atmosphere if it is not handled properly. Polyolester oil should be stored in metal containers. Plastic containers should not be used because they allow moisture to permeate into the oil.

Yearly oil analysis is recommended to verify the continued use of the compressor oil.



It is very important to take the oil sample after the oil filter. The slide valve cylinder has two pressure service ports that are ideal for drawing the oil sample. The oil sample should not be left open to the atmosphere for more than 15 minutes since it will absorb moisture from the atmosphere and may yield erroneous results.

Compressor oil should be changed when the oil analysis indicates the oil has moisture and acid numbers are in excess of the limits set in Table 7.

TABLE 7 – COMPRESSOR OIL LIMITS

| YORK OIL TYPE | MOISTURE CONTENT (by Karl Fisher) ppm | TAN (Total Acid Number) mgKOH/ml |
|---------------|---------------------------------------|----------------------------------|
| C | LESS THAN 50 PPM | LESS THAN 0.05 |
| H | LESS THAN 300 PPM | LESS THAN 0.5 |
| S | LESS THAN 300 PPM | LESS THAN 0.5 |

The YORK YS Chiller Compressors use rolling element bearings (ball and roller bearings); no sleeve bearings are used. Oil analysis that include metals may cause confusion when the results are compared to other equipment that utilize different bearing types. Iron and copper are examples of metals, which will appear in oil analysis that include metals. Other metals that may appear are Titanium, Zinc, Lead, Tin and Silicon. These metals should be ignored and are acceptable in quantities of less than 100 ppm. If a oil analysis should indicate high levels of Iron (more than 300 ppm) combined with Chromium and Nickel (more than 50 ppm), consult your local YORK Service Office – this could indicate bearing damage and wear.

The immersion oil heater will maintain the oil temperature between 105°F (40°C) and 115°F (46°C). The immersion oil heater is interlocked with the oil level float and will be de-energized when the oil level float drops to the low oil safety set point. See Figure 28.

Changing Compressor Oil

Compressor oil is changed by draining oil from the oil separator into a refrigerant recovery container. The oil separator is under positive pressure at ambient temperatures. Connect one end of a 5/8 inch refrigeration charging hose to the service valve located at the bottom of the oil separator; connect the other end to an approved refrigerant recovery cylinder. Open the valve and drain the oil from the oil separator.

Weigh the empty refrigerant recovery cylinder (compressor oil weighs 7 lb/gallon). Calculate the number of gallons of oil that has been removed from the oil separator by weighing the refrigerant recovery cylinders with the oil in them.

Use a hand or electric oil pump to pump new oil into the oil separator. Pump oil into the oil separator until the oil is approximately half way in the upper sight glass. The

amount of oil removed from the oil separator should equal the amount of new oil pumped into the oil separator.

Oil Level

A visual check is sufficient to verify the oil level. Two sight glasses are part of the oil separator and should be used to determine the proper operating oil level.

The upper sight glass should have liquid oil visible in the sight glass with the chiller off and the oil at 105°F (40°C) and 115°F (46°C). When the chiller is in operation, the oil level may be different from the standby condition, due to the turbulence created by the discharge gas in the oil separator. See Figure 28.

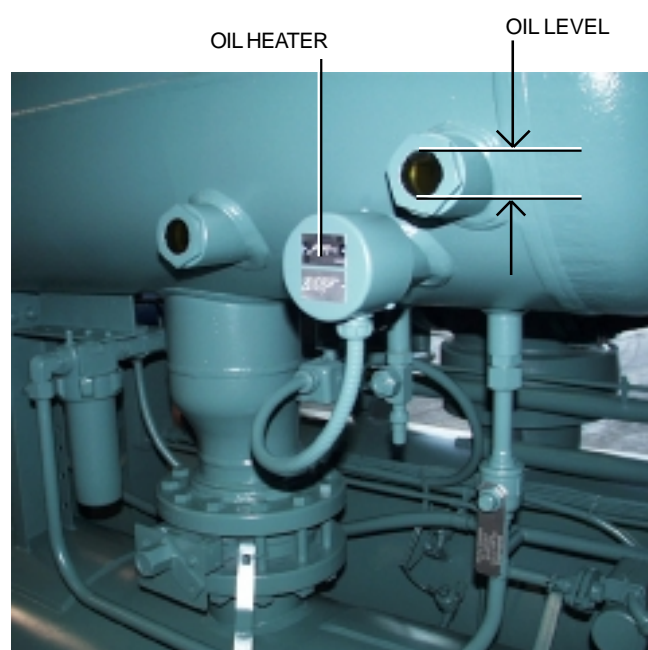

00206VIP

FIG. 28 – OIL HEATER AND SIGHT GLASSES

OIL FILTER

A single oil filter is provided as standard equipment and dual oil filter arrangements are available as optional equipment. The oil filter(s) are a replaceable 3 micron cartridge type oil filter. Use only YORK approved oil filter elements. See Figure 17.

The oil filter element should be changed after the first 200 hours of operation and then as necessary thereafter. Change the oil filter element before the differential pressure reaches 20 PSID. Always replace the oil filter element and o-ring on a yearly maintenance schedule.

The YORK control panel will automatically display the message “DIRTY OIL FILTER” when the differential

pressure reaches 20 PSID across the oil filter. A safety shutdown will be initiated if the oil pressure differential pressure reaches 25 PSID. The control panel will display the message “CLOGGED OIL FILTER”

OIL FILTER REPLACEMENT

Single Oil Filter

The chiller must be OFF. Turn the rocker switch to the OFF position; turn the circuit breaker to the OFF position to prevent the chiller from being accidentally started.

1. Close the hand isolation valves on the inlet and outlet oil lines going to and from the oil filter.
2. Relieve the refrigerant pressure and oil in the oil filter and the oil lines through the pressure access port fitting, located on the top of the filter housing. Connect a refrigeration pressure hose to the pressure access port and drain the oil and refrigerant into a suitable refrigerant recovery container.
3. Position a container to collect the oil (less than 2 quarts, 1.9 liters). Loosen and remove the drain nut at the bottom of the oil filter housing; drain the oil into the container.
4. Unscrew the oil filter bowl.
5. Remove the oil filter element.
6. Install a new element.
7. Install a new O-ring on the top of the oil filter bowl.
8. Tighten the oil filter bowl.
9. Evacuate the air from the oil filter to 500 microns PSIG.
10. Open the hand isolation valves.
11. The chiller is ready to be restarted.

Dual Oil Filters

The dual oil filter option allows one oil filter to be isolated and changed with the chiller in operation.

1. Open the hand isolation valves on the idle filter.
2. Close the hand isolation valves on the filter to be changed.
3. Follow the instructions for changing the single oil filter beginning at step #2.
4. This can now be the idle filter and the chiller can be operated with the current oil filter.

MAINTENANCE REQUIREMENTS FOR YORK YS CHILLERS

TABLE 8 – MAINTENANCE REQUIREMENTS FOR YORK YS CHILLERS

| PROCEDURE | DAILY | WEEKLY | MONTHLY | QUARTERLY | YEARLY | EVERY 50,000 HOURS |
|--|-------|--------|---------|-----------|---------------------|--------------------|
| Record Operating Pressures and Temperatures | X | | | | | |
| Check Oil and Refrigerant Levels | | X | | | | |
| Check Operation of Oil Heater | | | X | | | |
| Check 3-Phase Voltage and Current Balance | | | | X | | |
| Leak Check and Repair Leaks *** | | | | X | | |
| Calibrate Safety Controls | | | | | X | |
| Check Slide Valve Operation and Calibrate Slide Valve Potentiometer | | | | | X | |
| Lubricate Motor Bearings (per Motor Manufacturer's Recommendation) & Clean Motor | | | | | X | |
| Mechanically Brush Condenser Tubes | | | | | X (or as necessary) | |
| Megohm Motor | | | | | X | |
| Perform Oil Analysis on Compressor Lube Oil *** | | | | | X | |
| Remove Condenser Water Box(s) and Inspect Tube Sheets | | | | | X | |
| Replace Filters/Driers | | | | | X | |
| Replace Oil Filter(s) **** | | | | | | X |
| Verify Evaporator and Condenser Water Flow Rates vs. Design Conditions | | | | | X | |
| Vibration Analysis | | | | | X | |
| Compressor Internal Inspection *** | | | | | | X |

*** These procedures must be performed at the specified time interval by an Industry Certified Technician, who has been trained and qualified to work on this type of YORK equipment. A record of this procedure being successfully carried out must be maintained on file by the equipment owner, should proof of adequate maintenance be required at a later date for warranty validation purposes.

**** Change oil filter(s) elements after the first 200 hours of operation.

FILTER DRIER REPLACEMENT

The filter driers should be changed annually or when excessive amount of oil is indicated in the refrigerant charge.

When the filter driers require changing the chiller must be shut off.

1. Close the (5) service isolation valves identified in schematic drawing, Figure 23.
2. Carefully remove the insulation on the (2) filter driers located on the eductor block.
3. Relieve the pressure from the circuit using the pressure access fitting located on the side of the eductor block. Connect a refrigeration pressure hose to the pressure access port and drain the oil and refrigerant into a suitable refrigerant recovery container.
4. Loosen the Rota-Lock® Nuts at each end of the (3) filter driers. Remove the filter driers.
5. Teflon® seal washers are used to seal the filter drier connections. These washers must be replaced when the filter driers are replaced.
6. Tighten the Rota-Lock® Nuts at each end of the three filter driers to a torque of 60 ft-lb.
7. Evacuate the air from the oil filter to 500 microns PSIG.
8. Open the five hand isolation valves. The chiller is now ready to be placed back into service.

MOTOR

Inspect the motor at regular intervals. Keep the motor clean and vent openings clear. Follow the original motor manufacturer recommendation for lubricating the motor bearings. If the chiller is exposed to dusty and dirty conditions during installation, lubricate the motor bearings ahead of the suggested schedule.

DETERMINING CORRECT REFRIGERANT CHARGE LEVEL

The refrigerant charge level is correct when the measured evaporator approach and discharge refrigerant gas superheat are within the values listed in Table 9.



IMPORTANT: The chiller must be at design operating conditions and full load operation before the correct refrigerant charge level can be properly determined.

TABLE 9 – REFRIGERANT CHARGE LEVEL

| CONDITION | R-22 REFRIGERANT | R-134a REFRIGERANT |
|--|---------------------|-----------------------|
| COMFORT COOLING APPLICATIONS | | |
| EVAPORATOR APPROACH | 1°F-5°F | 1°F-5°F |
| DISCHARGE SUPERHEAT | 35°F-45°F | 12°F-18°F |
| BRINE (ICE MAKING) APPLICATIONS | | |
| EVAPORATOR APPROACH | 4°F-8°F | 4°F-8°F |
| DISCHARGE SUPERHEAT | 45°F-65°F | 24°F-36°F |

Liquid refrigerant will be visible in the evaporator sight glass. The refrigerant level cannot be properly determined by viewing the liquid refrigerant level in the evaporator sight glass.

All YS Chillers shipped Form 1 are charged with the correct amount of refrigerant. Under some operating conditions the chiller may appear to be overcharged or undercharged with refrigerant. Consult with the YORK Factory prior to removing or adding refrigerant. The liquid line isolation valve may have to be partially throttled to prevent overfeeding the evaporator in some applications and under certain operating conditions.

Definitions:

$$\text{Evaporator Approach} = (\text{S.E.T}) - (\text{L.E.L.T})$$

$$\text{Discharge Superheat} = (\text{C.D.G.T}) - (\text{S.C.T})$$

Where:

S.E.T. = Saturated Evaporator Temperature

L.E.L.T. = Leaving Evaporator Liquid Temp.

C.D.G.T. = Compressor Discharge Gas Temp.

S.C.T. = Saturated Condensing Temperature

These values can be obtained from the Graphic Control Center. Refer to Graphic Control center Operating Instructions, Form 160.80-01.

REFRIGERANT CHARGING

Should it become necessary to add refrigerant charge to a YORK YS Chiller; add charge until the evaporator approach and refrigerant gas discharge superheat are at within the values listed in Table 9.

A charging valve is located in the liquid line below the evaporator. The size of the charging connection is 3/4 inch male flare. Purge air and non-condensables from the charging hose. Only add new refrigerant, or refrigerant that has been tested and certified to meet American Refrigeration Institute Standard (ARI-700).

REFRIGERANT LEAK CHECKING

Periodic refrigerant leak checking must be part of a comprehensive maintenance program. Leak check the entire chiller using a calibrated electronic leak detector.

Confirm leaks with soap bubbles that are found using the electronic leak detector.

Check refrigerant relief valve piping and tube rolled joints as part of the comprehensive refrigerant leak checking program.

Repair leaks before adding refrigerant.

OIL TEMPERATURE CONTROL

A valve has been added to the liquid refrigerant line supply liquid refrigerant to the oil cooler (See Fig. 29). This valve has been added beginning with design level “E” chillers. The purpose of the valve is to regulate the amount of liquid refrigerant being supplied to the oil cooler. Set the valve to maintain oil temperature at 80°F to 100°F. *Note the most sever oil cooling load is when the chiller is unloaded.* Allow the chiller to operate for a period of time while monitoring the oil temperature. The valve may require as little as 1/2 turn open for some applications.



FIG. 29 – OIL COOLER VALVE

00207VIP

PRESSURE CONNECTIONS

All threaded pressure connections used on the YORK YS Chillers are SAE straight thread, O-ring face seal type fittings or Primore Rotalock[®] fittings.

The O-ring straight thread fittings and O-ring face seal fittings are designed and used in accordance with SAE J1926 and J1453. Should it become necessary to remove a fitting, the O-ring(s) should be replaced. Make certain to use only neoprene replacement O-rings. O-rings can be ordered from the local YORK Service Office.

Pipe sealant compounds are not required with SAE type O-ring fittings. The O-ring seal accomplishes the pressure sealing. Lubricate the O-ring with compressor oil prior to assembly.

All filter driers and angle shut off valves use Primore Rotalock[®] fittings. These fittings use a Teflon[®] fiber seal washer. The Teflon[®] fiber seal washers should be replaced each time the filter driers are changed.

CONDENSER TUBES

The standard condenser tubes used in YORK YS Chillers are internally enhanced copper tubes.

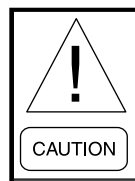

If the equipment is located in an unheated area that is susceptible to freezing, the water must be drained from the condenser to prevent tube failure from freezing.

Proper condenser water treatment can eliminate or significantly reduce the formation of scale on the water-side of the condenser tubes.

Maintain a minimum condenser water flow rate through the tubes of at least 3.33 ft/sec. (1 meter/sec.). Through tube water velocity should not exceed 12 ft/sec. (3.6 meter/sec.).

Condenser tubes must be maintained to provide proper chiller operation. Condenser Approach Temperature is a useful tool to monitor the performance of the condenser. By recording and logging the Condenser Approach Temperature as part of the chiller maintenance program, this will provide a warning that the waterside condenser tubes are fouled and require cleaning.

Condenser Approach Temperature is the difference between the Condenser Leaving Water Temperature and the Saturated Condensing Temperature.

If the approach increases above 10°F (5.6°C), or during the annual condenser inspection and the tubes are observed to be fouled, the tubes will require cleaning. For

condenser fluids other than water consult with the local YORK Field Service Office for the correct condenser approach.

CONDENSER WATER SIDE TUBE CLEANING PROCEDURE

Two methods are used for waterside tube cleaning to remove the scale; chemical and mechanical cleaning procedures. The composition of the scale will determine which method will be most effective to remove the scale and dirt.

Consult with the local YORK Field Service Office for a recommendation of the method(s) used in the local area.

Chemical Cleaning Procedure

Chemical cleaning is an effective method to remove scale from internally enhanced copper tubes. However, a company knowledgeable with the chemical cleaning procedure should be contracted or consulted. Follow the chemical cleaning company recommendations concerning solution cleaning strength and time duration of the cleaning process.



Serious damage to the condenser tubes will result if the chemical cleaning procedure is improperly applied.

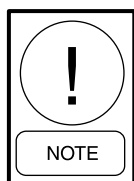

Mechanical tube cleaning must always follow a chemical cleaning procedure.

When chemical cleaning of the condenser tubes is required, it may be necessary to calculate the internal volume of the waterside condenser tubes. This information is necessary to properly mix the correct concentration of cleaning solution.

Standard materials of construction for YORK YS Chiller condensers is copper tubes and mild carbon steel water boxes.

The internal volume (waterside) of the condenser can be calculated as follows:

$$\text{Volume (in}^3\text{)} = N * L * 0.30680 \text{ in}^3/\text{in}$$

Where: N = Number of Condenser Tubes
L = Length of each Tube in inches

To convert in³ to gallons, divide the Volume (in³) by 231 in³/gallon.

Mechanical Cleaning Procedure

1. Drain the water from the condenser.
2. Remove the water boxes from both ends of the condenser. Use proper lifting equipment when removing the water boxes. Use caution not to damage the threads on the mounting studs that are welded to the tube sheet.
3. Select a tube cleaning brush for 5/8 inch I.D copper condenser tubes. If tubes other than 5/8 inch copper are used, select a tube cleaning brush that is made for the tube size. Generally, brushes made of hard plastic or brass bristled wires are preferred for cleaning copper tubes.
4. Attach the tube cleaning brush to the end of a cleaning machine or cleaning rod.
5. Flush the condenser with clean water to remove the debris.
6. Replace the water box gasket with a new gasket and reassemble the water boxes onto the condenser.

EVAPORATOR TUBES

The standard evaporator tubes used in YORK YS Chillers are internally enhanced copper tubes.



If the equipment is located in an unheated area that is susceptible to freezing, the water must be drained from the evaporator to prevent tube damage from freezing.

Maintain evaporator water or brine flow rates through the evaporator tubes that the chiller was designed for. Refer to the engineering data on the sales order form for the correct flow rates.

Generally, the water or brine that is circulated through the evaporator is part of closed loop circuit that is treated with chemicals to prevent the formation of scale and debris.

If cleaning of the evaporator tubes is required, follow the condenser cleaning procedure.

MEGOHM THE MOTOR

Make certain that the motor disconnect switch (circuit breaker) is in the open position. Megohm the motor as follows:

1. Use a megohm meter to verify the minimum motor and wiring insulation resistance. Megohm between phases and each phase to ground, refer to Fig. 30, Diagram, Megohm Motor Windings. Refer to Fig. 31, Motor Stator Temperature and Insulation resistances.

2. If insulation resistance values fall to the left of the curve, remove external leads from the motor and repeat test.

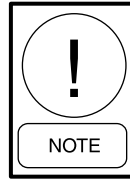

Motor is to be megged with the starter at ambient temperature after 24 hours of idle standby.

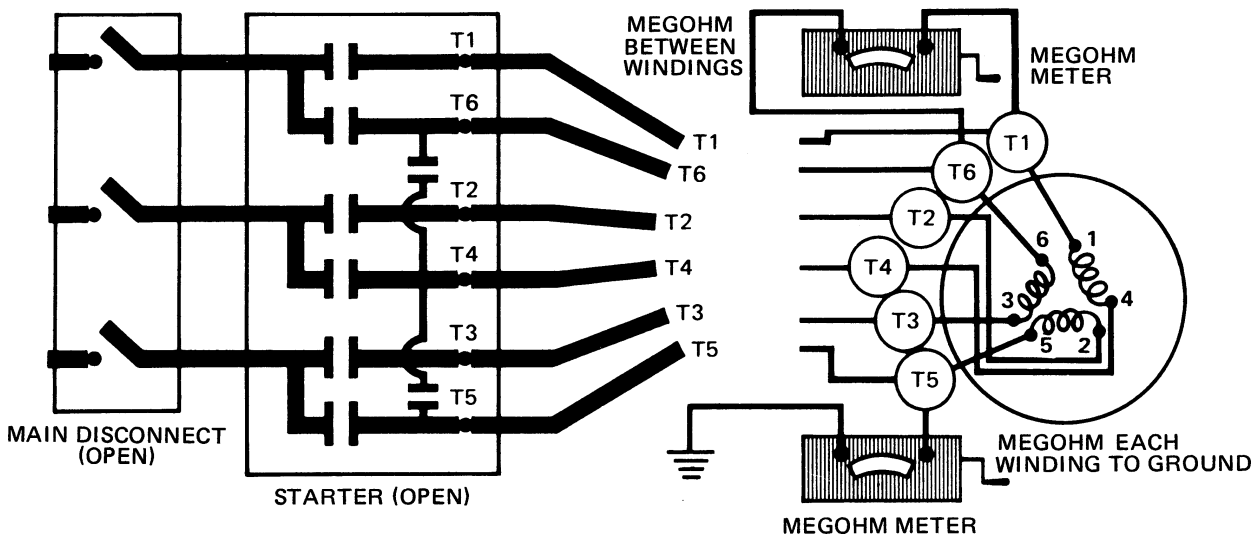

LD00475

FIG. 30 – DIAGRAM, MEGOHM MOTOR WINDINGS

FIG. 31 – MOTOR STATOR TEMPERATURE AND INSULATION RESISTANCES

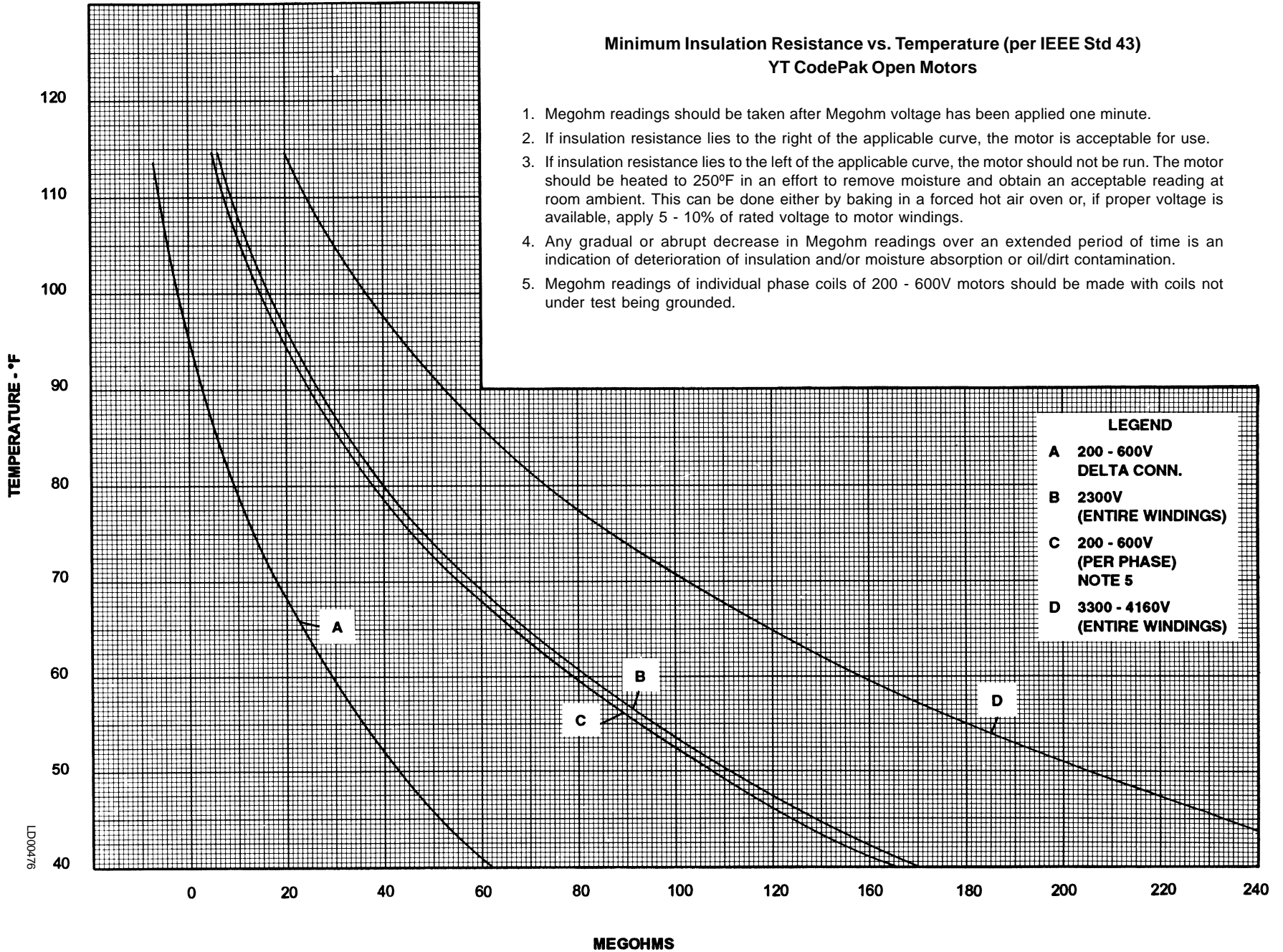

VIBRATION ANALYSIS

Vibration analysis performed at yearly intervals is a useful diagnostic that can detect internal damage to rotating machinery and component parts. This service should be performed by a skilled technician trained in the use and operation of the equipment. Fig. 32 is provided to properly locate the transducer measurement points. Locat-

ing the transducers at these locations will enable the data to be analyzed against a large database of sound and vibration data.

Note the natural or pumping frequency of the YORK YS compressor is 238 HZ (14,280 CPM) at 60 HZ and 198 HZ (11,880 CPM) at 50 HZ operation.

SPECTRAL ALARM BANDS FOR 4/6 LOBE TWIN SCREW CHILLERS

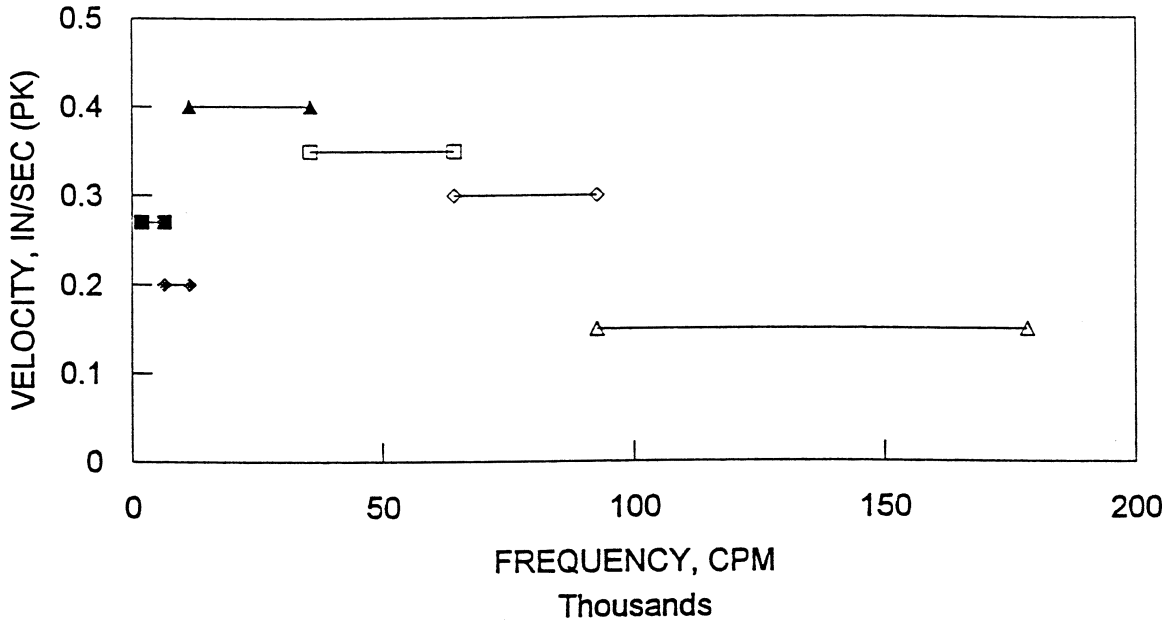

| | |
|------------------------------------|------------------------------------|
| ■ MOTOR/MALE RTR & FEMALE RTR RPM | □ 3X - 4X COMPR. PUMPING FREQUENCY |
| ◆ 2X - 3X MOTOR/MALE ROTOR | ◇ 5X - 6X COMPR. PUMPING FREQUENCY |
| ▲ 1X - 2X COMPR. PUMPING FREQUENCY | △ >6X COMPR. PUMPING FREQ. - FMAX |

LD04382

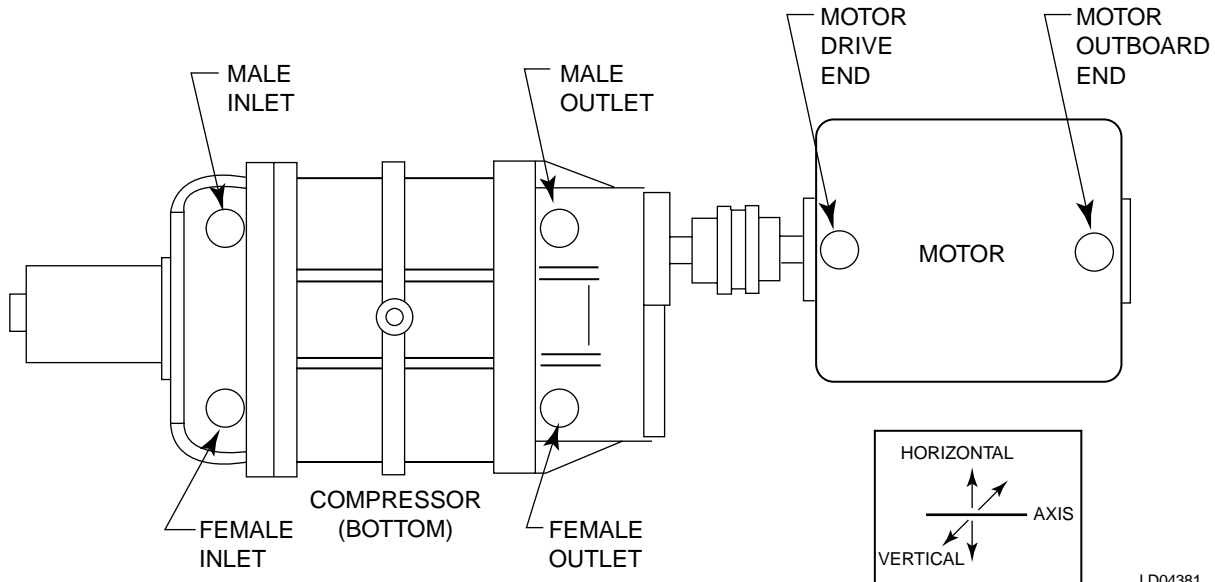

LD04381

FIG. 32 – TRANSDUCER MEASUREMENT POINTS

SPECTRAL ALARM BANDS FOR 4/6 LOBE TWIN SCREW CHILLERS

Reference: Proven method for specifying spectral band alarm levels and frequencies using today's predictive maintenance software systems

James E. Berry, Technical Associates of Charlotte, Inc.

| | | | | |
|-------------------|------|--------|---------------|------------|
| OVERALL LEVEL | OA | 0.500 | IN/SEC (0-PK) | |
| MTR/MALE RTR RPM | MTR | 3570 | RPM = | 59.5 HZ |
| 4/6 LOBE RATIO | LR | 0.67 | | |
| FEMALE ROTOR | IDLE | 2380 | RPM = | 39.7 HZ |
| MALE ROTOR LOBES | LOB | 4 | | |
| PUMPING FREQUENCY | BPF | 14280 | CPM = | 238.0 HZ |
| FREQUENCY MAX | FMAX | 178500 | CPM = | 2,975.0 HZ |

| ITEM | BAND 1 | BAND 2 | BAND 3 | BAND 4 | BAND 5 | BAND 6 |
|-----------------------|--------|--------|--------|--------|--------|---------|
| BAND LOWER FREQ., CPM | 1,904 | 6,426 | 11,424 | 35,700 | 64,260 | 92,820 |
| BAND UPPER FREQ., CPM | 6,426 | 11,424 | 35,700 | 64,260 | 92,820 | 178,500 |
| BAND LOWER FREQ., HZ | 32 | 107 | 190 | 595 | 1,071 | 1,547 |
| BAND UPPER FREQ., HZ | 107 | 190 | 595 | 1,071 | 1,547 | 2,975 |
| BAND ALARM LEVEL | 0.27 | 0.2 | 0.4 | 0.35 | 0.3 | 0.15 |

DESCRIPTION OF BAND COVERAGE

| | |
|--------|--------------------------------------|
| BAND 1 | MOTOR/MALE RTR & FEMALE RTR RPM |
| BAND 2 | 2X - 3X MOTOR/MALE ROTOR |
| BAND 3 | 1X - 2X COMPR. PUMPING FREQUENCY |
| BAND 4 | 3X - 4X COMPR. PUMPING FREQUENCY |
| BAND 5 | 5X - 6X COMPR. PUMPING FREQUENCY |
| BAND 6 | >6X COMPR. PUMPING FREQUENCY - FMAX. |

NOTES:

1. Assume measurements by accelerometer or velocity pickup as close as possible to Bearing Housing, see Fig. 32.
2. Assume machine NOT mounted on vibration isolators (for isolated machinery - set alarm levels 50% higher).
3. Set motor levels same as compressor given above.
4. Chiller must be at a consistent condition (not only motor amps) when measurements are taken. Monitor and record all performance parameters.
5. Aerodynamic noise (pressure pulsation) sources dominate mechanical sources at pumping frequency and harmonics and does not represent energy transmitted through bearings.
6. Set danger levels 50% higher than alarm levels.
7. Another set of data with much higher Fmax can be used to detect additional stages of bearing failure using techniques described in Preventative Maintenance literature.

OIL RECOVERY

YS Chiller Best Practice Oil Recovery Method

A skilled service technician can recover oil from the refrigerant charge in the evaporator in less than 60 minutes.

Before starting the chiller, print a **History** print. This will help you determine the reason for the oil loss. The operating conditions are stored in memory in a history buffer file. Connect a printer and press the **History** print key.

1. If the chiller was shut off on **LOW OIL LEVEL** safety: Place a jumper wire between terminals 1 and 18 to satisfy the control circuit.
2. Start the chiller in **AUTO** mode of operation.
3. As soon as the chiller starts, remove the jumper wire from between terminals 1 and 18. (This was installed in Step 1.)
4. In the automatic mode of operation, the slide valve will be force loaded to establish differential pressure. A minimum pressure differential of 30 PSID (oil supply pressure relative to evaporator pressure) must be met within the first three minutes of chiller operation or the chiller will be shut off on a **LOW PRESSURE** safety.

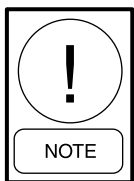

If the entering condenser water is cold, turn off the condenser pump or regulate that amount of water flowing through the condenser to establish the necessary pressure differential. Recommended, entering condenser water temperature should be at least 15°F or greater than the leaving chilled water temperature.

5. Press the **FILTER PRESSURE** key and monitor the **DIFF PRESS** as soon as the 30 PSID pressure differential has been established. Press the **UNLOAD** key to unload the slide valve.
6. Calculate the compressor discharge superheat (DSH).

$$\begin{aligned} \text{Compressor DSH} = & \\ & (\text{Condenser Discharge Temperature}) \\ & - (\text{Saturated Condensing Temperature}) \end{aligned}$$

Monitor the compressor DSH. When the compressor DSH is equal to, or greater than, 15°F, press the **LOAD** key for one second and then press the **HOLD** key.

7. Recalculate the compressor DSH. Do not increase the slide valve position until the compressor DSH is equal to, or greater than, 15°F.

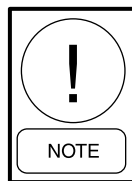

*Refer to Figure 33. This is a comparison of the compressor DSH vs. Time and Slide Valve Position vs. Time. This plot is from a YSBBBBS1-CHD chiller. Three additional gallons of oil were added and all the oil was transferred from the oil separator into the evaporator until the chiller shut off on **LOW OIL LEVEL** safety. Use this chart as a guide for oil recovery. Actual field conditions will determine how large the slide valve incremental increase can be to maintain compressor DSH of 15°F or greater.*

The process of recovering oil from the refrigerant charge is dependent on compressor DSH, time and slide valve position.

During the initial phase of the oil recovery process, the slide valve position can not be increased more than 2% - 3% without lowering the compressor DSH to below 10°F. If the slide valve position is increased too rapidly, the increase in compressor suction velocity will entrain oil/refrigerant foam with the suction gas. The entrained oil/refrigerant foam will lower the compressor discharge temperature and the compressor DSH to less than 10°F. If the compressor DSH is less than 10°F, an **EXCESS CHARGE OVERRIDE** protection is initiated and the slide valve will be automatically unloaded. Further loading of slide valve will be inhibited until the compressor DSH increases to above 15°F.

*Notice the sequence of events that begin at the nine-minute interval on Figure 33. The technician increases the slide valve position from 8% to 13%. This incremental change was too large - notice the compressor DSH is reduced from 17.8°F to 9.9°F. Since the **EXCESS CHARGE OVERRIDE** threshold of 10°F was exceeded, the slide valve was automatically unloaded to 0%. Beginning at the eleven-minute interval, the technician was careful to maintain compressor DSH at higher levels until the oil was recovered.*

As more oil is removed from the refrigerant, larger incremental slide valve increases are possible, and the compressor DSH will remain above 15°F. **Be patient, let**

the compressor DSH be your guide. Moving the slide valve in increments that are too large will only result in the oil recovery process taking longer than necessary.

- When the slide valve position is at least 40% and the compressor DSH is above 25°F, the chiller can be placed in the AUTO mode of operation. Press the AUTO key.

- Press the STATUS key. The message WARNING – EXCESS CHARGE will appear. To clear this message, press the WARNING RESET key.

- Determine the reason for the OIL LOSS/REFRIG-ERANT CHARGE messages and take necessary action to prevent reoccurrence.

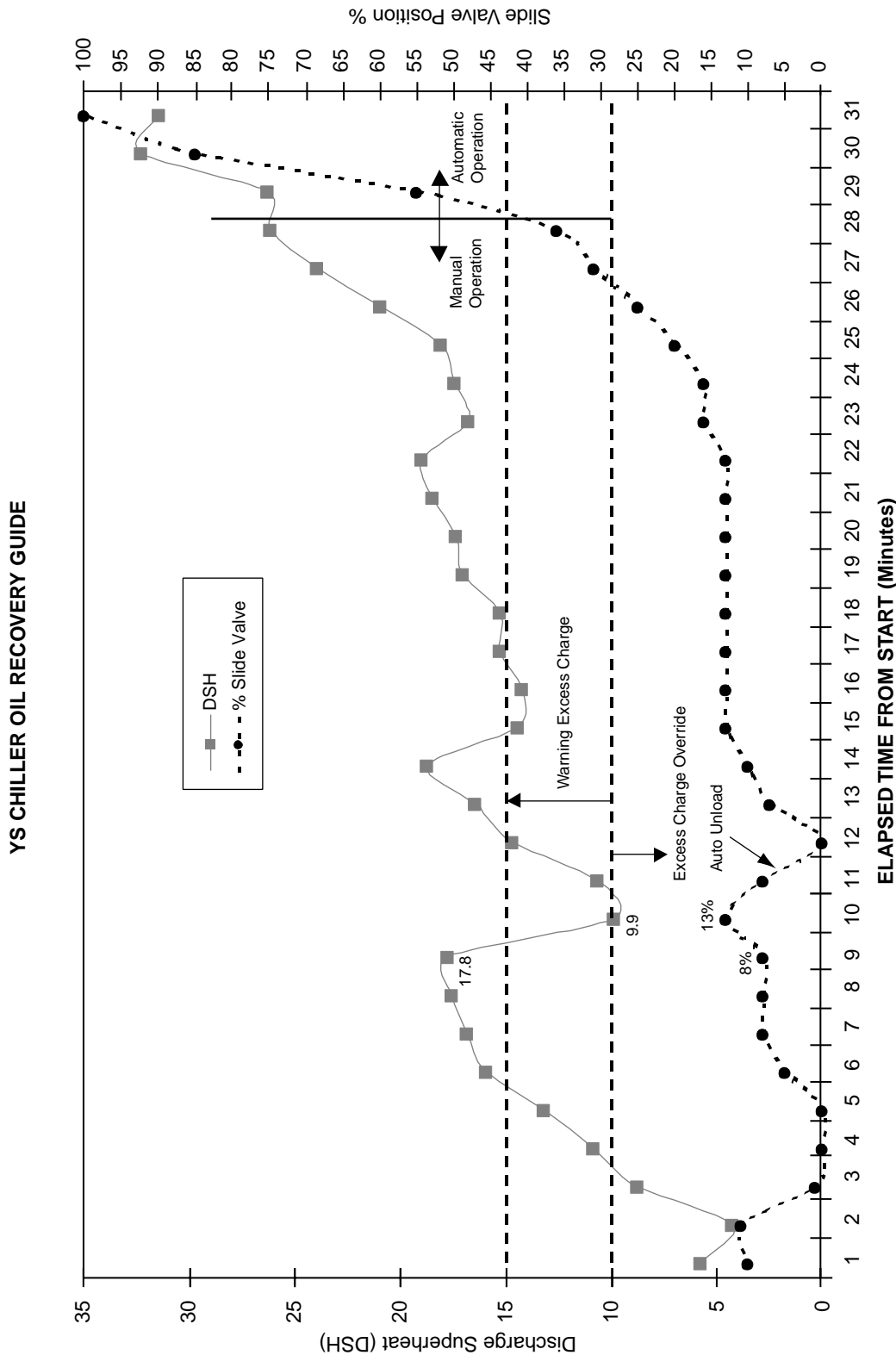

YSBBBS1-CHD Off on Low Oil Separator Level safety, additional three gallons of oil added to evaporator

LD04903

FIG. 33 – YS CHILLER OIL RECOVERY GUIDE

VACUUM DEHYDRATION

Should the chiller be opened to the atmosphere for lengthy repair or service, follow the Vacuum Dehydration Guidelines in Form 160.47-N3.1 (1099), Field Re-Assembly for Form 3 & Form 7 Shipment of Model YS Chillers, to ensure that all air, moisture and non-condensable gases are removed prior to placing the chiller into service.

NOTES

