 PRODUCT DRAWING	Supersedes: Nothing FORM 160.47-PW12 (798)
	WIRING DIAGRAM MILLENNIUMYS (STYLE D) ROTARY SCREW CHILLER MICROCOMPUTER CONTROL CENTER WITH YORK SOLID STATE STARTER
YORK INTERNATIONAL CORPORATION P.O. Box 1592, YORK, PA 17405	
CONTRACTOR _____ ORDER NO. _____ YORK CONTRACT NO. _____ YORK ORDER NO. _____	PURCHASER _____ JOB NAME _____ LOCATION _____ ENGINEER _____
<input type="checkbox"/> REFERENCE DATE _____	<input type="checkbox"/> APPROVAL DATE _____
<input type="checkbox"/> CONSTRUCTION DATE _____	

JOB DATA:

CHILLER MODEL NO. YS _____

NO. OF UNITS _____

COMPRESSOR MOTOR _____ VOLTS, 3-PHASE, _____ HZ

REMARKS: _____

ELEMENTARY DIAGRAM

REF. 035-15941-000, REV A

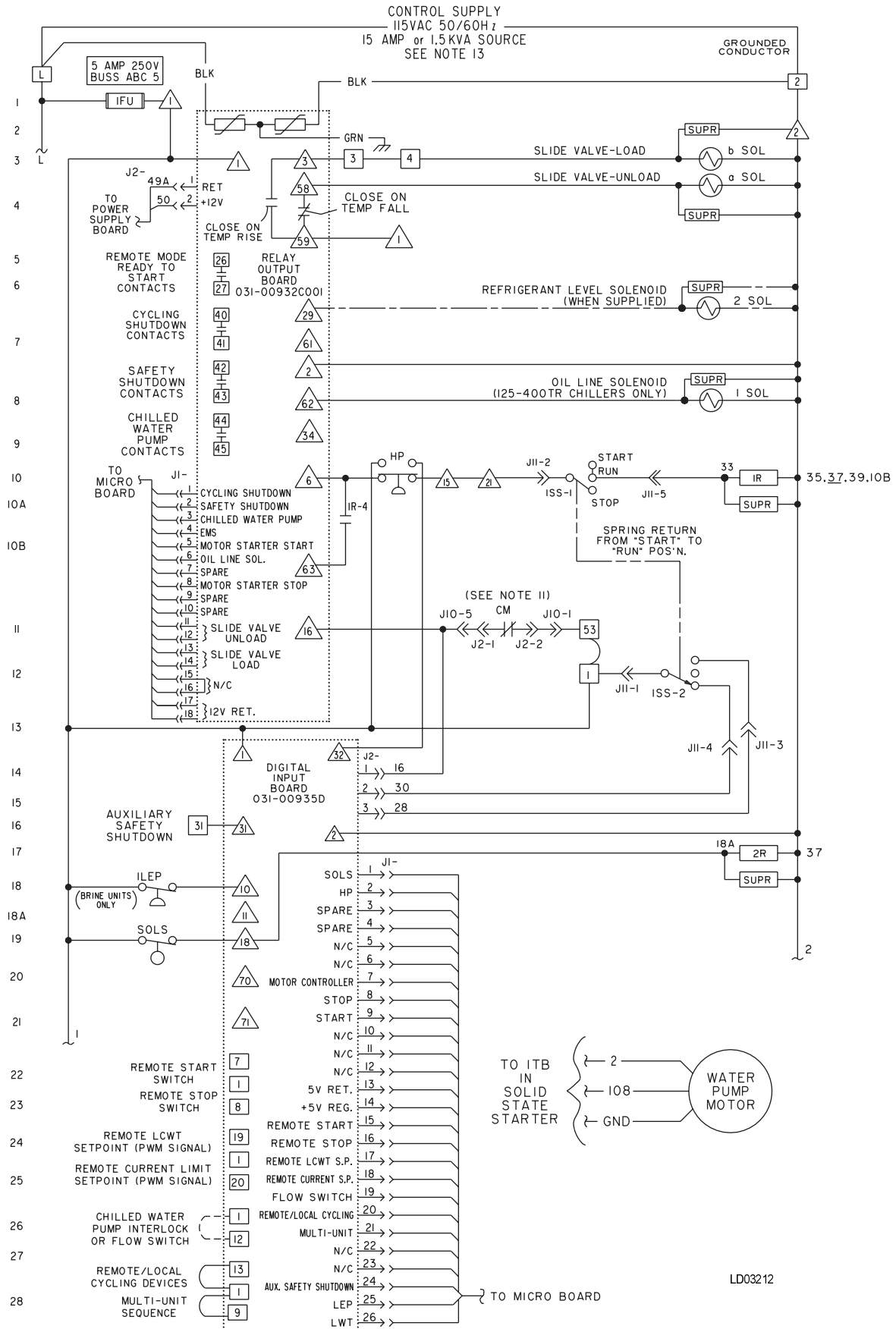

(Cont'd. on pages 3 & 4)

ELEMENTARY DIAGRAM

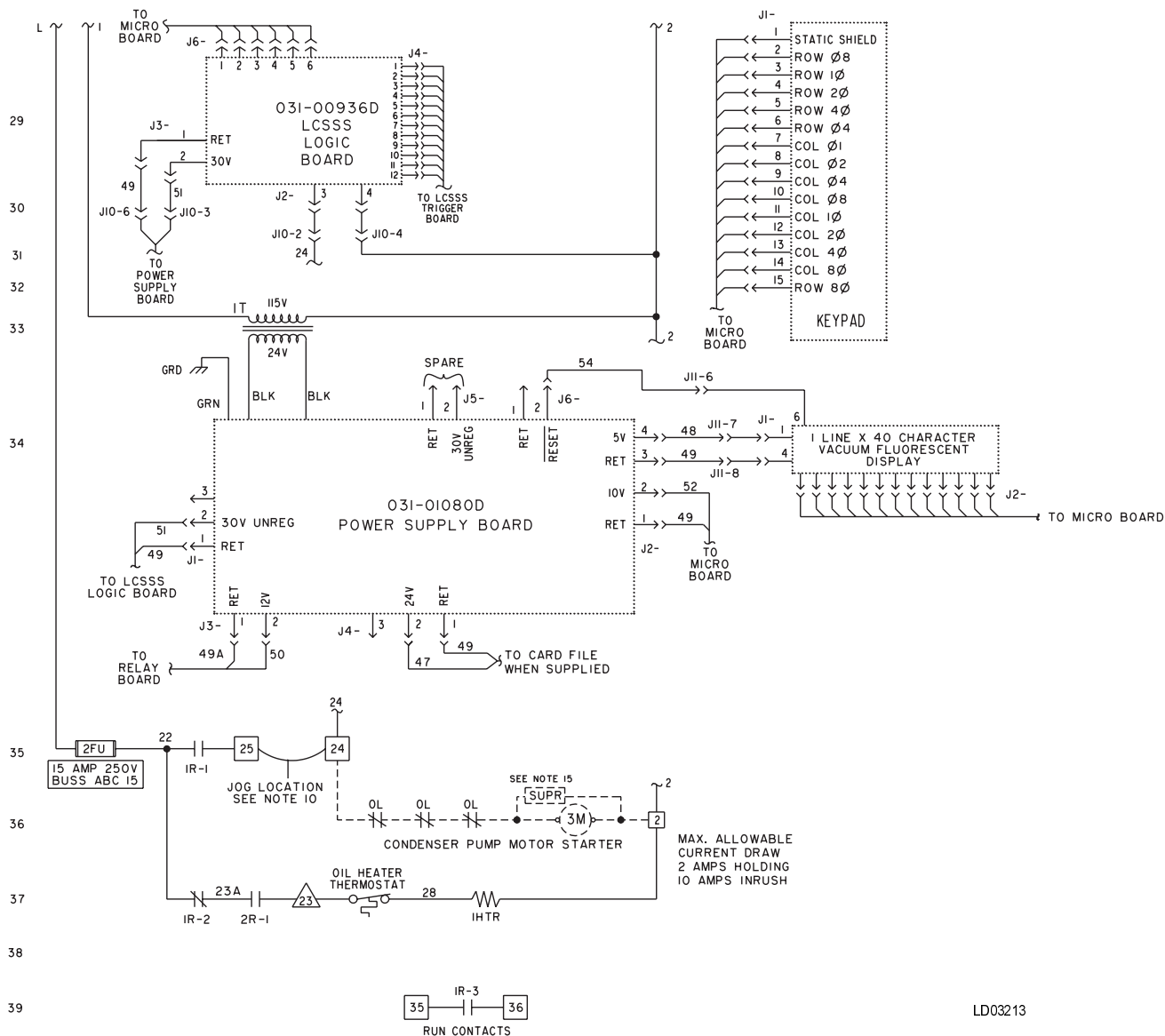

LD03213

DISPLAY MESSAGE

TIMING DIAGRAM

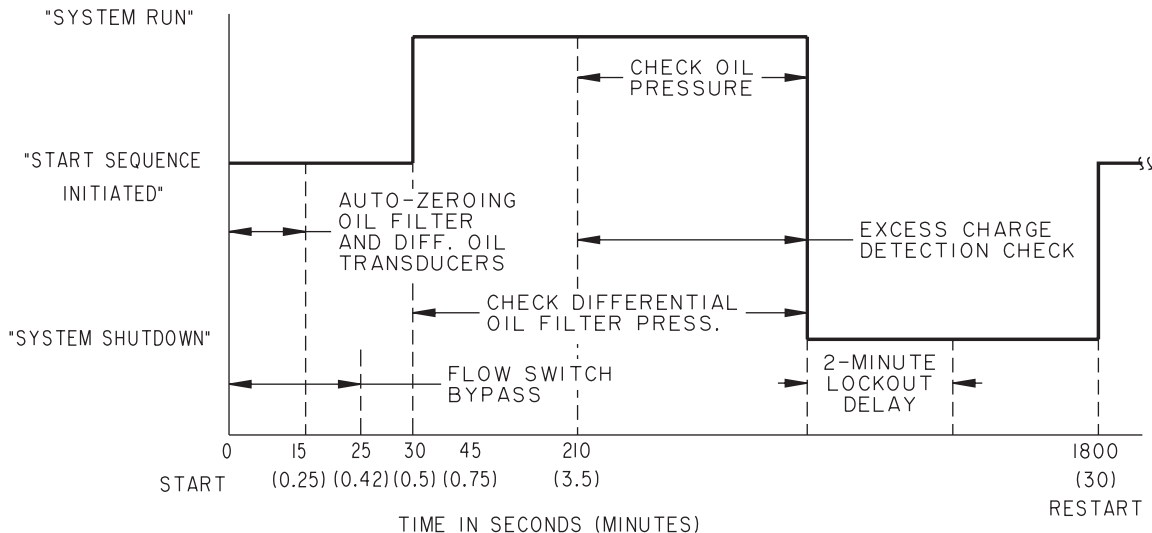

LD03214

ELEMENTARY DIAGRAM

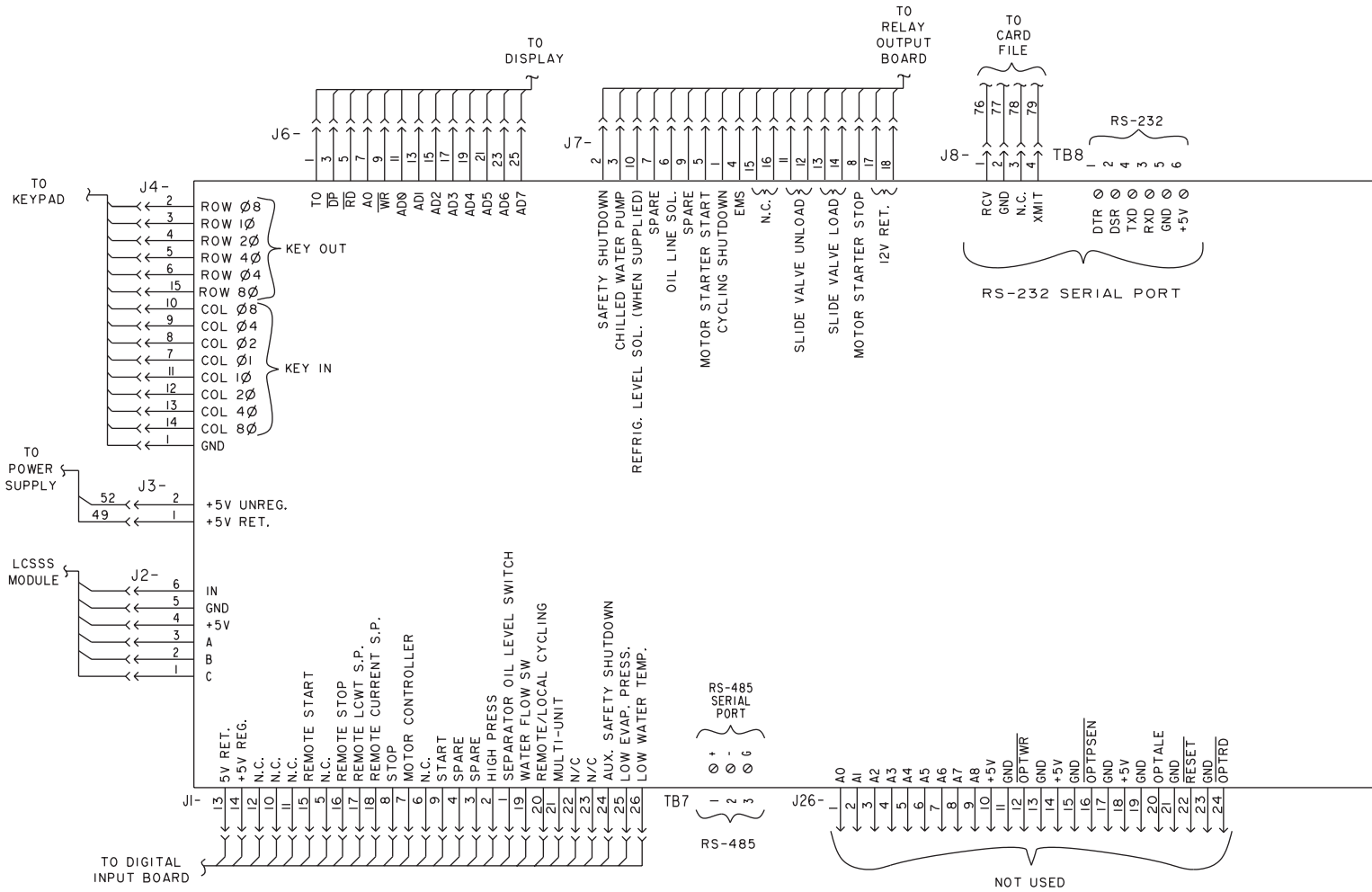



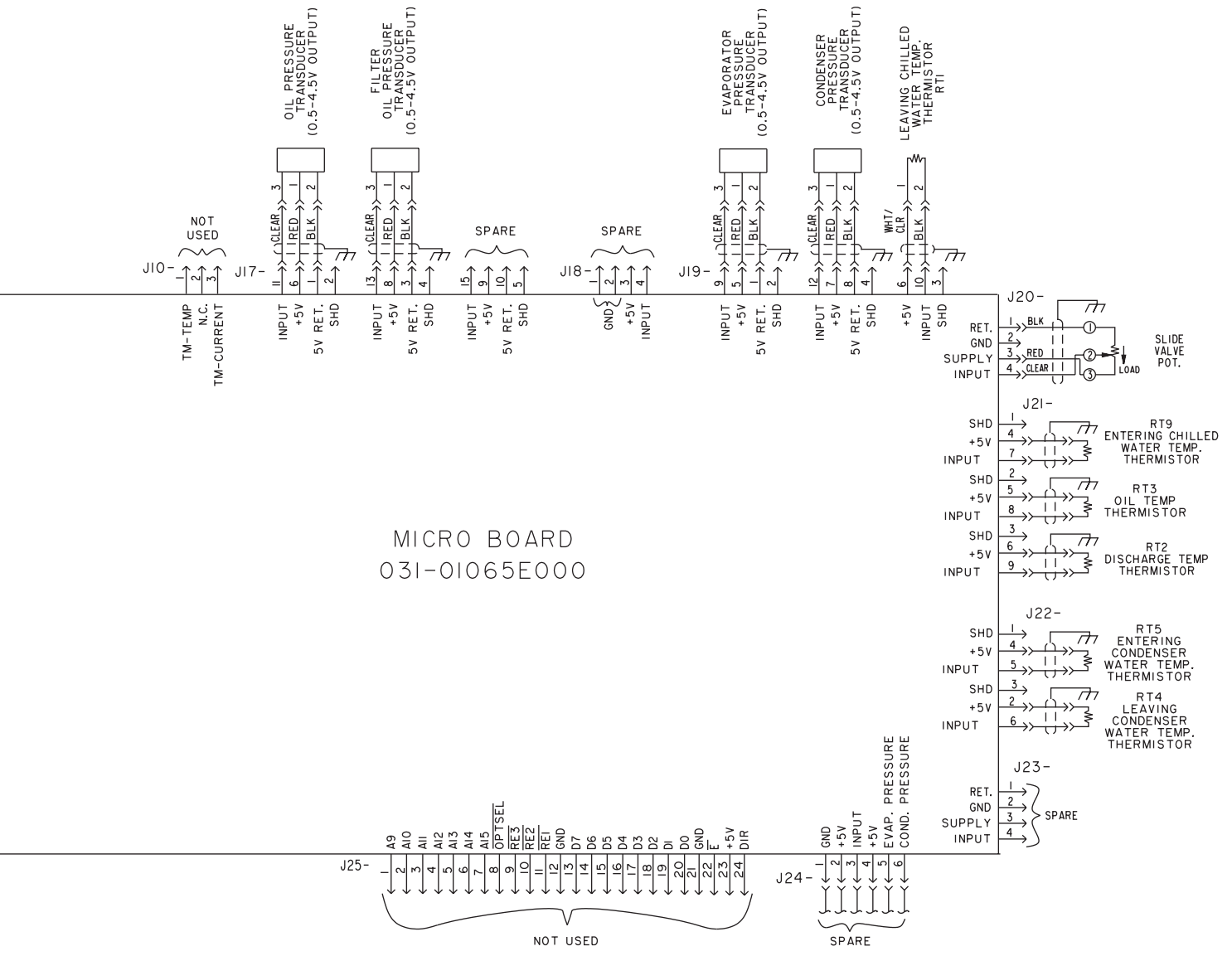



ELEMENTARY DIAGRAM

















LD03215

LEGEND

a SOL	SLIDE VALVE-UNLOAD	MOV	METAL OXIDE VARISTOR
b SOL	SLIDE VALVE-LOAD	OL	MOTOR STARTER OVERLOADS
IHTR	500 WATT OIL HEATER	SOLS	SEPARATOR OIL LEVEL SWITCH
3M	CONDENSER PUMP MOTOR STARTER	RT1-RT9	RESISTANCE TEMPERATURE SENSING ELEMENT
IR	COMPRESSOR MOTOR/ HEATER CONTROL RELAY	RES	RESISTOR
ISOL	OIL LINE SOLENOID (125-400 TR CHILLERS ONLY)		TRANSIENT SUPPRESSOR
2SOL	REFRIGERANT LEVEL SOLENOID (WHEN SUPPLIED)		
ISS	DPDT 3 POSITION ROCKER SWITCH	TB1,TB3,TB6	TERMINAL BLOCK, FACTORY WIRING — 
ITB	TERMINAL BLOCK, FACTORY WIRING (IN SOLID STATE STARTER)	TB2,TB4,TB5	TERMINAL BLOCK, FIELD CONNECTION — 
IT	CLASS 2 POWER SUPPLY TRANSFORMER	----	FIELD WIRING
CM	{ SOLID STATE OVERLOAD/POWER FAULT CONTACTS (PART OF LCSSS LOGIC BOARD)	—	FACTORY WIRING
FDTS	FAULTY DISCHARGE TEMP. SENSOR	CIRCUIT BOARD OR ENCLOSURE BOUNDARY
FLA	FULL LOAD AMPS (COMPRESSOR MOTOR)	→	JACK (J1,J2,...)
FU	FUSE	⌋	PLUG (P1,P2,...)
HDT	REFRIG. HIGH DISCHARGE TEMP. (PROVIDED BY RT2)		WIRE ENTRANCE HOLE IN CONTROL PANEL
HOP	HIGH OIL PRESSURE	----	OPTION (WHEN SUPPLIED) BY YORK.
HOT	HIGH OIL TEMPERATURE (PROVIDED BY RT3)	----	MECHANICAL LINKAGE
HP	HIGH PRESSURE CUTOUT		SHIELDED CABLE
LEP	LOW EVAPORATOR PRESSURE (PROVIDED BY EVAP. PRESS TRANSDUCER)		METAL OXIDE VARISTOR
LOP	LOW OIL PRESSURE		
ILEP	LOW EVAPORATOR PRESSURE CUTOUT (BRINE UNITS ONLY)		
LOT	LOW OIL TEMPERATURE (PROVIDED BY RT3)		
LWT	LOW WATER TEMPERATURE (PROVIDED BY RT1)		

LD03216

NOTES:

1. This wiring diagram describes the standard electronic control scheme for use with a YORK Solid State Starter. For details of standard modifications, refer to Product Drawing Form 160.47-PW5.
2. Field wiring to be in accordance with the National Electrical Code as well as all other applicable codes and specifications. See Product Drawing Form 160.47-PW4 for field wiring connections.
3. Numbers along the left side of diagram are line identification numbers. The numbers along the right side indicate the line number location of relay contacts. An underlined contact location signifies a normally closed contact.
4. Main control panel Class 1 field wiring terminal connection points are indicated by numbers within a rectangle, i.e.  . Main control panel factory wiring terminal connection points are indicated by numbers within a triangle, i.e.  . Component terminal markings are indicated by numbers within a circle, i.e.  . Numbers adjacent to circuit lines are the circuit identification numbers.
5. To cycle unit on and off automatically with contacts other than those shown, install a cycling device between terminals  &  (line 27) (see Note 7). If a cycling device is installed, jumper must be removed between terminals  &  .
6. To stop unit and not permit it to start again, install a stop device between terminals  &  (line 23) (see Note 7). A Remote start-stop switch may be connected to terminals  ,  &  (lines 22 and 23) (see Note 7). Remote start-stop switch (line 22) is operative only in the "remote" operating mode.
7. Device contact rating to be 5 milliamperes at 115 volts A.C.
8. Contact rating is 5A resistive @ 120 volts A.C. or 240 volts A.C.
9. For wiring diagram of solid state starter, refer to Product Form 160.47-PW6.
10. To check motor rotation on initial start-up, install momentary switch between terminals  &  (line 35). Depress start switch, after approx. 30 seconds, jog motor with momentary switch. When proper rotation is obtained, replace momentary switch with jumper. Switch must have a minimum contact rating of 2 FLA, 10 LRA at 115 volts A.C.
11. Solid state starter overload contact (CM) on solid state starter logic board is set to trip at 105% FLA. Contact also opens for 1 second during momentary power interruption (power fault).
12. Contact rating is 5 amps resistive @ 250 volts A.C. & 30 volts D.C., 2 amp inductive (0.4 PF) @ 250 volts A.C. & 30 volts D.C.
13. Field connected control power supply is not required, as control transformer is supplied on the rear of the solid state starter.
14. Wires 2* and L* are from solid state starter.
15. Each 115VAC field-connected inductive load, i.e. relay coil, motor starter coil, etc. shall have a transient suppressor wired in parallel with its coil, physically located at the coil. Spare transient suppressors and control circuit fuses are supplied in a bag attached to the top of the hinged panel.
16. Low oil pressure (LOP) safety shutdown occurs when oil pressure – evaporator pressure differential is less than 15 psi following a 3 minute bypass at compressor start.

PRESSURE – TEMPERATURE CHART							
APPLICATION		DEVICE	UNITS	OPERATING POINT			
CHILLED WATER	BRINE			ON RISE	ON FALL		
✓	✓	HDT	DEG.F/DEG.C	212/100	211/99.4		
✓	✓	HOT	DEG.F/DEG.C	170/76.7	169/76.1		
✓	✓	HOT WARNING	DEG.F/DEG.C	165/73.9	160/71.1		
✓	✓	LOP	SEE NOTE 16				
✓	✓	HP	PSIG/ kPa	CUT-OUT 270/1862	INHIBIT SLIDE VALVE LOADING * 251.3/1733	ALLOW SLIDE VALVE LOADING * 250/1724	CUT-IN 210/1448
✓		LEP (R-22)	PSIG/ kPa	CUT-IN 54.4/375	ALLOW SLIDE VALVE LOADING 57.5/396	INHIBIT SLIDE VALVE LOADING 56.2/387	CUT-OUT 54.3/374
✓		LEP (R-134 a)	PSIG/ kPa	CUT-IN 25.1/173	ALLOW SLIDE VALVE LOADING 28.0/193	INHIBIT SLIDE VALVE LOADING 27.0/186	CUT-OUT 25.0/172
	✓	ILEP	PSIG				
✓	✓	HOP	PSID/ kPa	300/2068			299/2062
✓	✓	FDTs	DEG.F/DEG.C	30.0/-1.10			29.9/-1.20
✓		LWT	DEG.F/DEG.C	CHILLED LIQUID TEMP. SETPOINT (FOR LWT RESTART PROGRAMMING RANGE SEE FORM 160.47-01.1)	AT OR ABOVE LCWT= 40/4.4, LWT=4/2.2 BELOW THE CHILLED LIQ. TEMP. SETPOINT: WHEN THE SETPOINT IS RAISED, LWT=36/2.2 FOR 10 MINUTES, BELOW LCWT=40/4.4, LWT=36/2.2		
	✓	LWT	DEG.F/DEG.C	CHILLED LIQUID TEMP. SETPOINT (FOR LWT RESTART PROGRAMMING RANGE SEE FORM 160.47-01.1)	LWT = 4/2.2 BELOW THE CHILLED LIQ. TEMP. SETPOINT: WHEN THE SETPOINT IS RAISED, LWT=4/2.2 BELOW THE PREVIOUS CHILLED LIQ. TEMP. SETPOINT FOR 10 MINUTES		
✓	✓	CLOGGED OIL FILTER	PSID/ kPa	25.0/172			24.9/172
✓	✓	DIRTY OIL FILTER WARNING	PSID/ kPa	20.0/138			19.9/137

* Function provided by condenser transducer

LD03217

LOW / HIGH VOLTAGE TRIP / RESET VALUES				
COMPRESSOR MOTOR SUPPLY VOLTAGE RANGE - (V)	LOW LINE VOLTAGE OPERATING POINT		HIGH LINE VOLTAGE OPERATING POINT	
	CUTOUT - (V) (ON FALL)	CUTIN - (V) (ON RISE)	CUTOUT - (V) (ON RISE)	CUTIN - (V) (ON FALL)
200-208	160	174	227	226
220-240	185	200	262	261
380	305	331	415	414
400	320	349	436	435
415	335	362	454	453
440-480	370	400	524	523
550-600	460	502	655	654
SUPPLY VOLTAGE RANGE DISABLED	NONE	0	NONE	0

LD03218

CONNECTION DIAGRAM

DOOR OPEN (REAR SIDE OF DOOR)

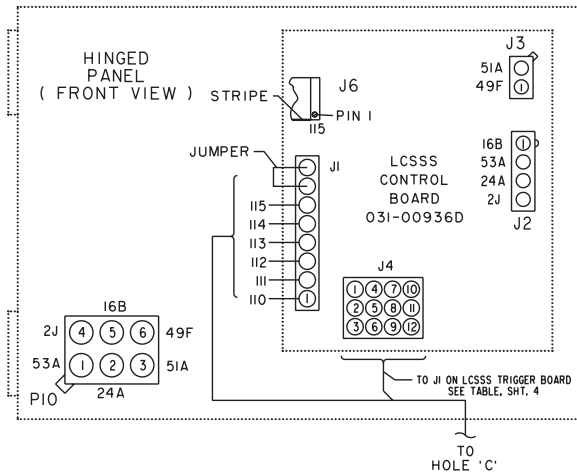
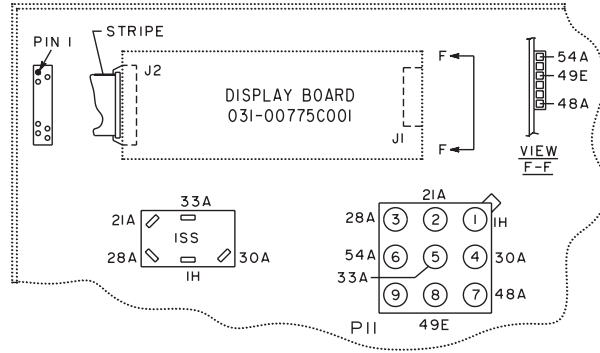

- TO REMOTE LCWT SET POINT (PWM SIGNAL) 1,19 -----
- (SEE NOTES 1,7)
- TO REMOTE CURRENT LIMIT SET POINT (PWM SIGNAL) 1,20 -----
- (SEE NOTES 1,7)
- TO CHILLED WATER PUMP CONTACTS 44,45 -----
- (SEE NOTES 12,15)
- TO REMOTE MODE READY TO START CONTACTS 26,27 -----
- (SEE NOTES 12,15)
- TO CYCLING SHUTDOWN CONTACTS 40,41 -----
- (SEE NOTES 12,15)
- TO RUN CONTACTS 35,36 -----
- (SEE NOTES 8,15)
- TO CONDENSER PUMP MOTOR STARTER 2,24 -----
- (SEE NOTE 15)
- TO CHILLED WATER PUMP INTERLOCK
OR FLOW SWITCH 1,12 -----
- (SEE NOTE 7)
- TO SAFETY SHUTDOWN CONTACTS 42,43 -----
- (SEE NOTES 12,15)
- TO AUXILIARY SAFETY SHUTDOWN CONTACTS 1, 3I -----
- (SEE NOTES 1,7)
- TO CONTACTS THAT CYCLE UNIT 1,7,8,13 -----
- (SEE NOTES 5,6,7)
- TO MULTI-UNIT SEQUENCE CONTACTS 1,9 -----
- (SEE NOTES 1,7)

(Cont'd. on pages 10 & 11)

CONNECTION DIAGRAM

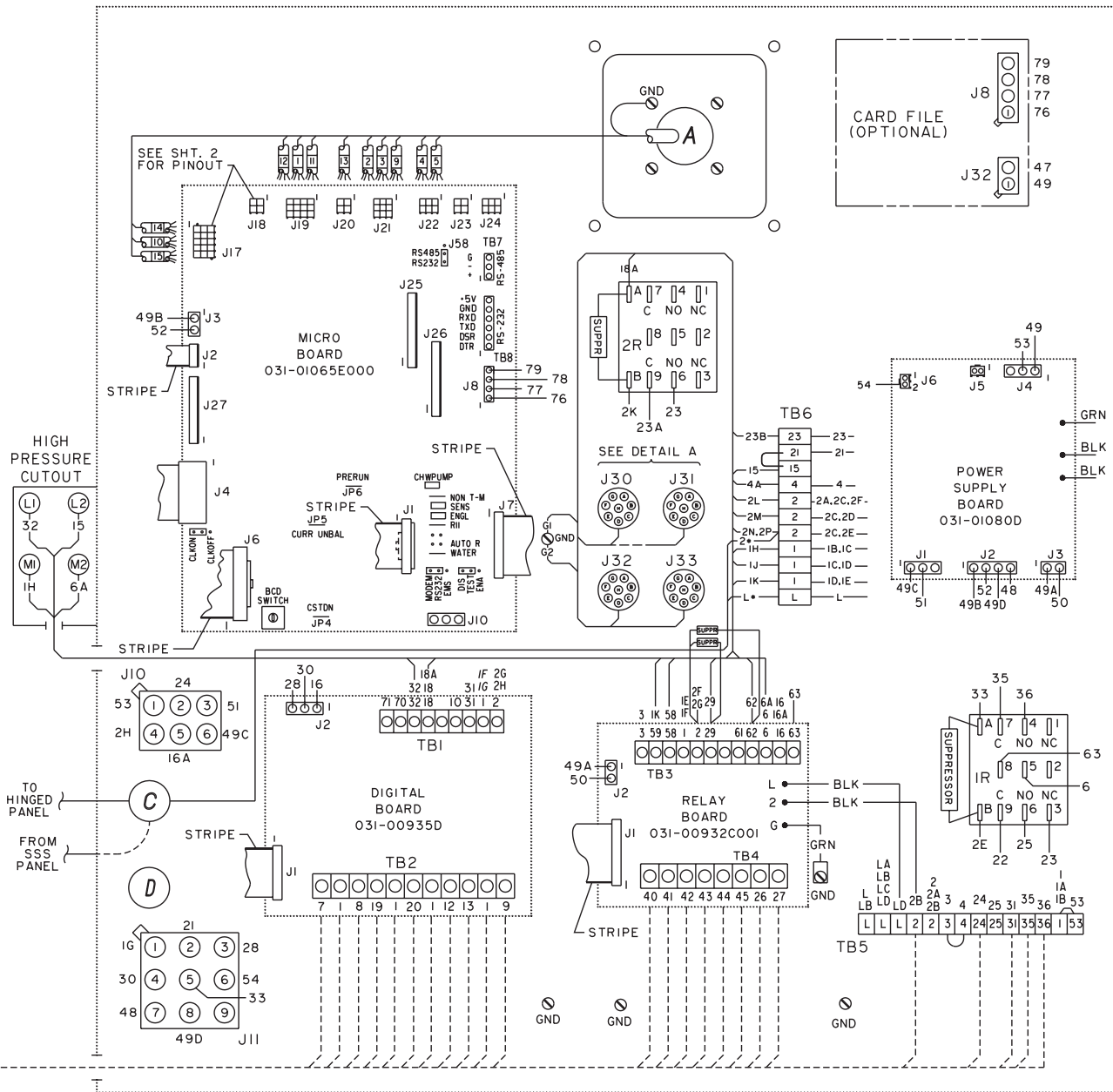

DETAIL A

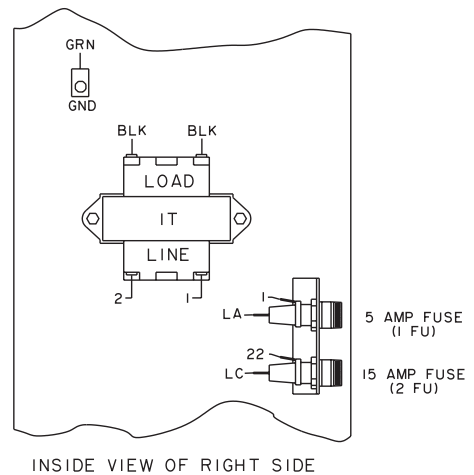
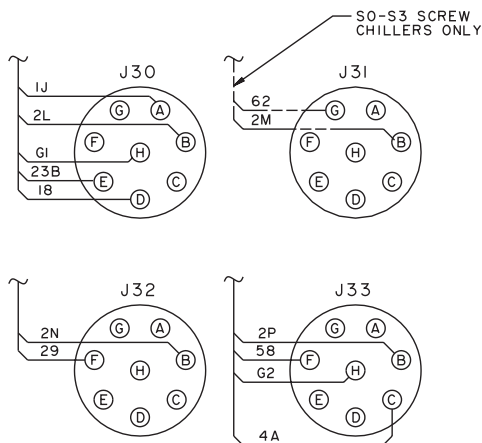

CONNECTION DIAGRAM

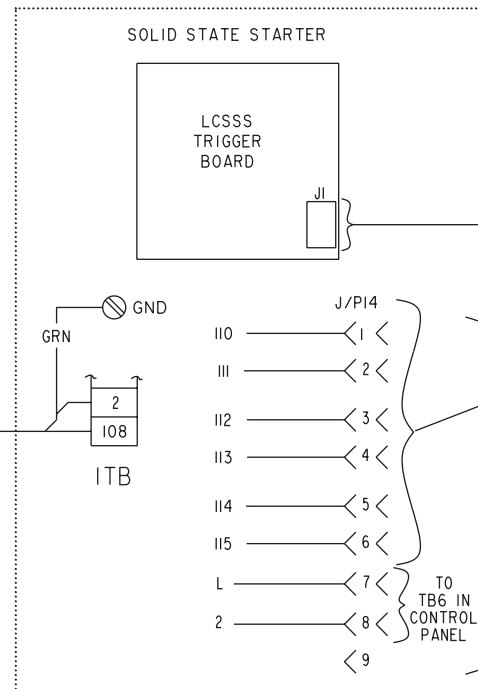
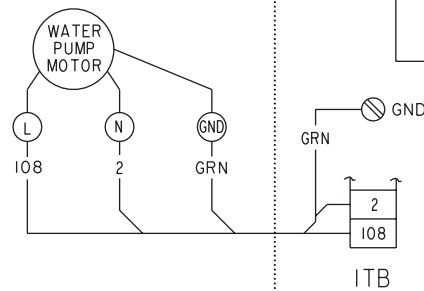
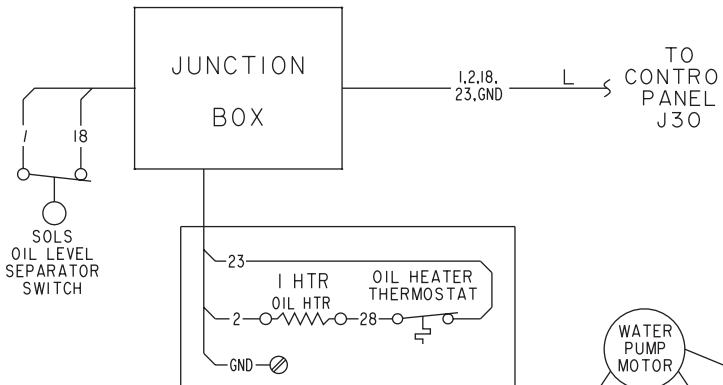
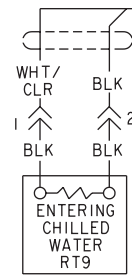
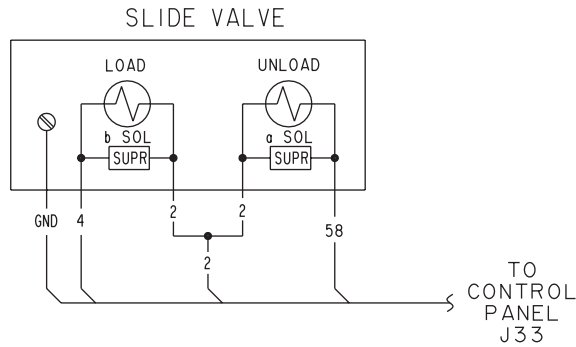
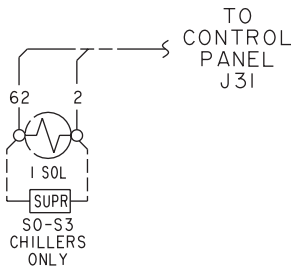
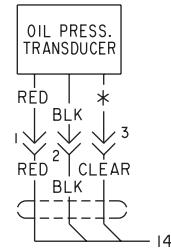
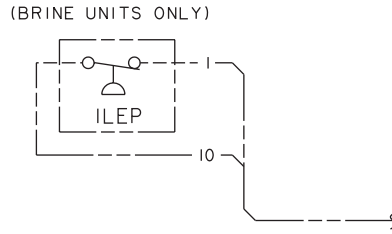
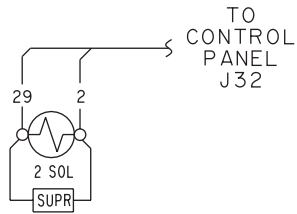

CONNECTION DIAGRAM

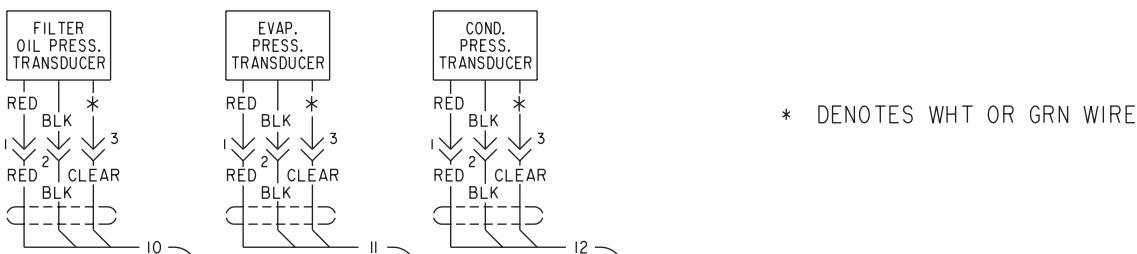

* DENOTES WHT OR GRN WIRE

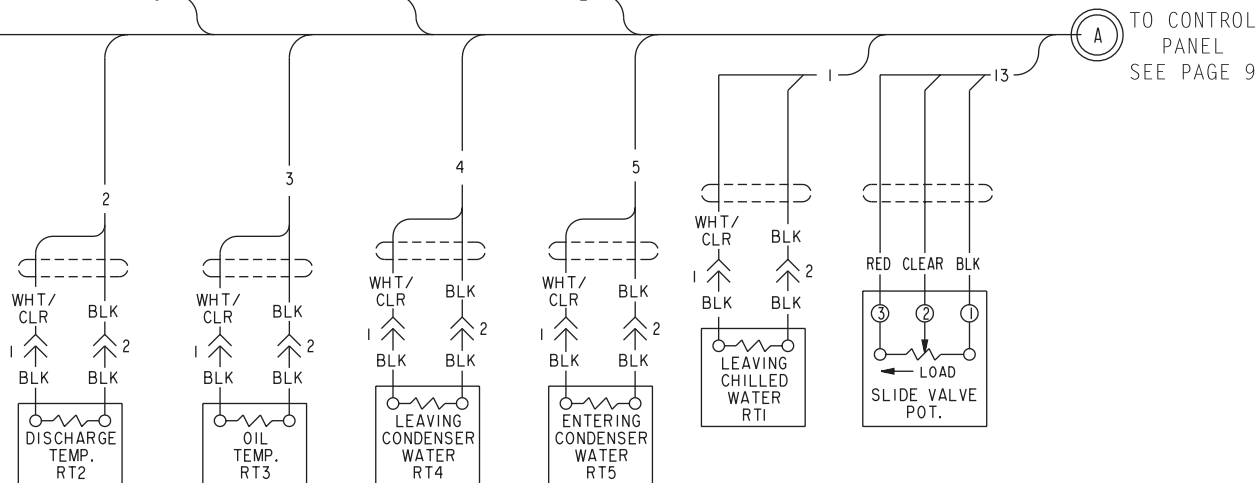

(A) TO CONTROL PANEL SEE PAGE 9

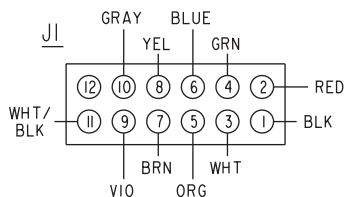

TO J4 ON LCSSS LOGIC BOARD SEE TABLE I

(C) TO CONTROL PANEL SEE PAGE 9

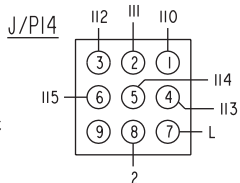

TO J1 ON LCSSS LOGIC BOARD

TABLE I

* CONNECTOR PIN	SHIELDED CABLE WIRE COLOR
1	BLK
2	RED
3	WHT
4	GRN
5	ORG
6	BLUE
7	BRN
8	YEL
9	VIOL
10	GRAY
11	WHT/BLK
12	DRAIN WIRE **

* - SAME PIN NUMBERS ARE USED AT BOTH ENDS OF CABLE
 ** - NOT CONNECTED TO TRIGGER BOARD

