 <b>PRODUCT DRAWING</b>	Supersedes: Nothing	FORM 160.47-PW1 (897)
	<b>WIRING DIAGRAM</b> <b>MILLENNIUMYS (STYLE C) ROTARY SCREW CHILLER</b> <b>MICROCOMPUTER CONTROL CENTER</b> <b>WITH ELECTRO-MECHANICAL STARTER</b>	
YORK INTERNATIONAL CORPORATION P.O. Box 1592, YORK, PA 17405		
CONTRACTOR _____ ORDER NO. _____ YORK CONTRACT NO. _____ YORK ORDER NO. _____	PURCHASER _____ JOB NAME _____ LOCATION _____ ENGINEER _____	
<input type="checkbox"/> REFERENCE    DATE _____	<input type="checkbox"/> APPROVAL    DATE _____	<input type="checkbox"/> CONSTRUCTION    DATE _____

**JOB DATA:**

CHILLER MODEL NO. YS \_\_\_\_\_

NO. OF UNITS \_\_\_\_\_

COMPRESSOR MOTOR \_\_\_\_\_ VOLTS, 3-PHASE, \_\_\_\_\_ HZ

**REMARKS:** \_\_\_\_\_

\_\_\_\_\_

\_\_\_\_\_

\_\_\_\_\_

\_\_\_\_\_

\_\_\_\_\_

# ELEMENTARY DIAGRAM

REF. 035-09973-000, REV D

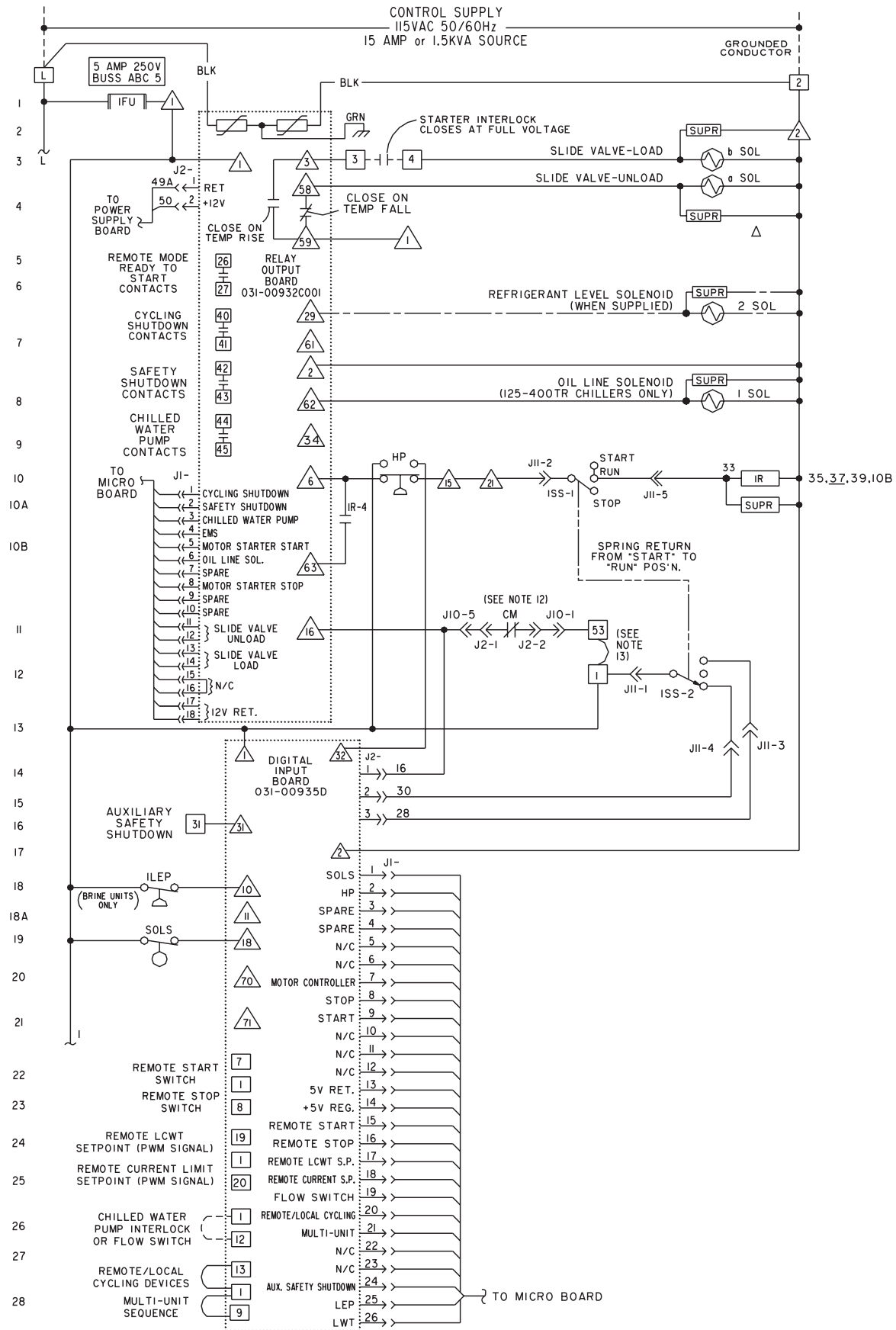

LD02399

(Cont'd. on pages 3 & 4)

### ELEMENTARY DIAGRAM

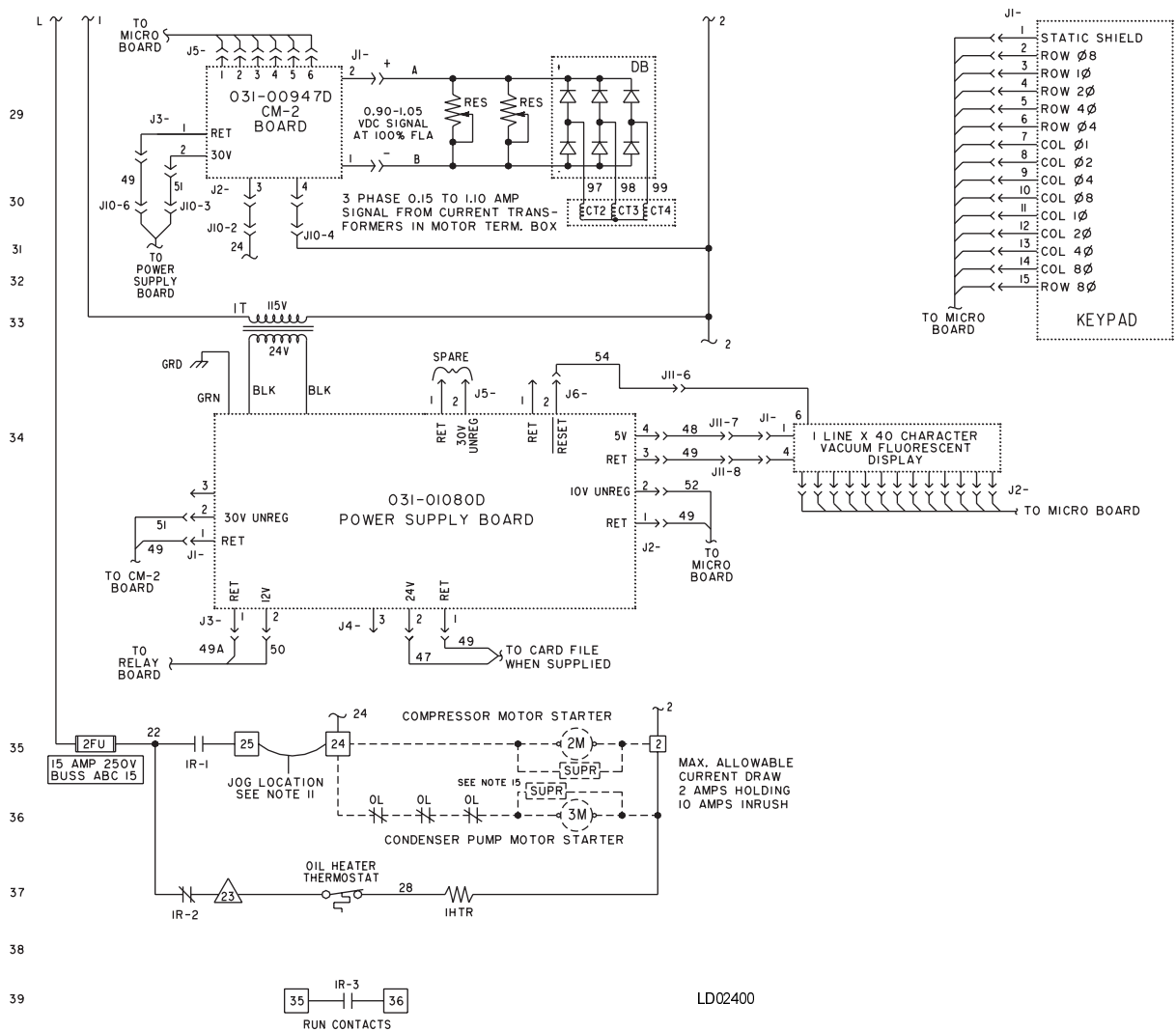

### TIMING DIAGRAM

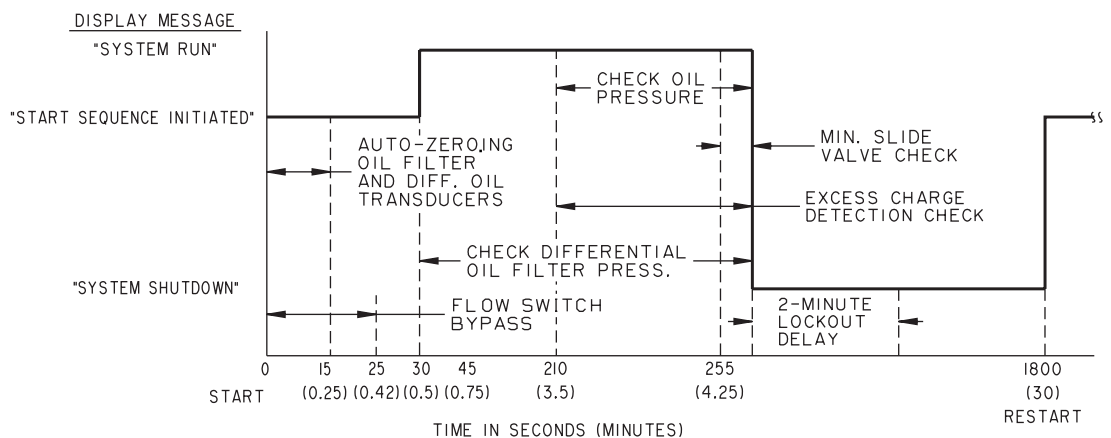

LD02401



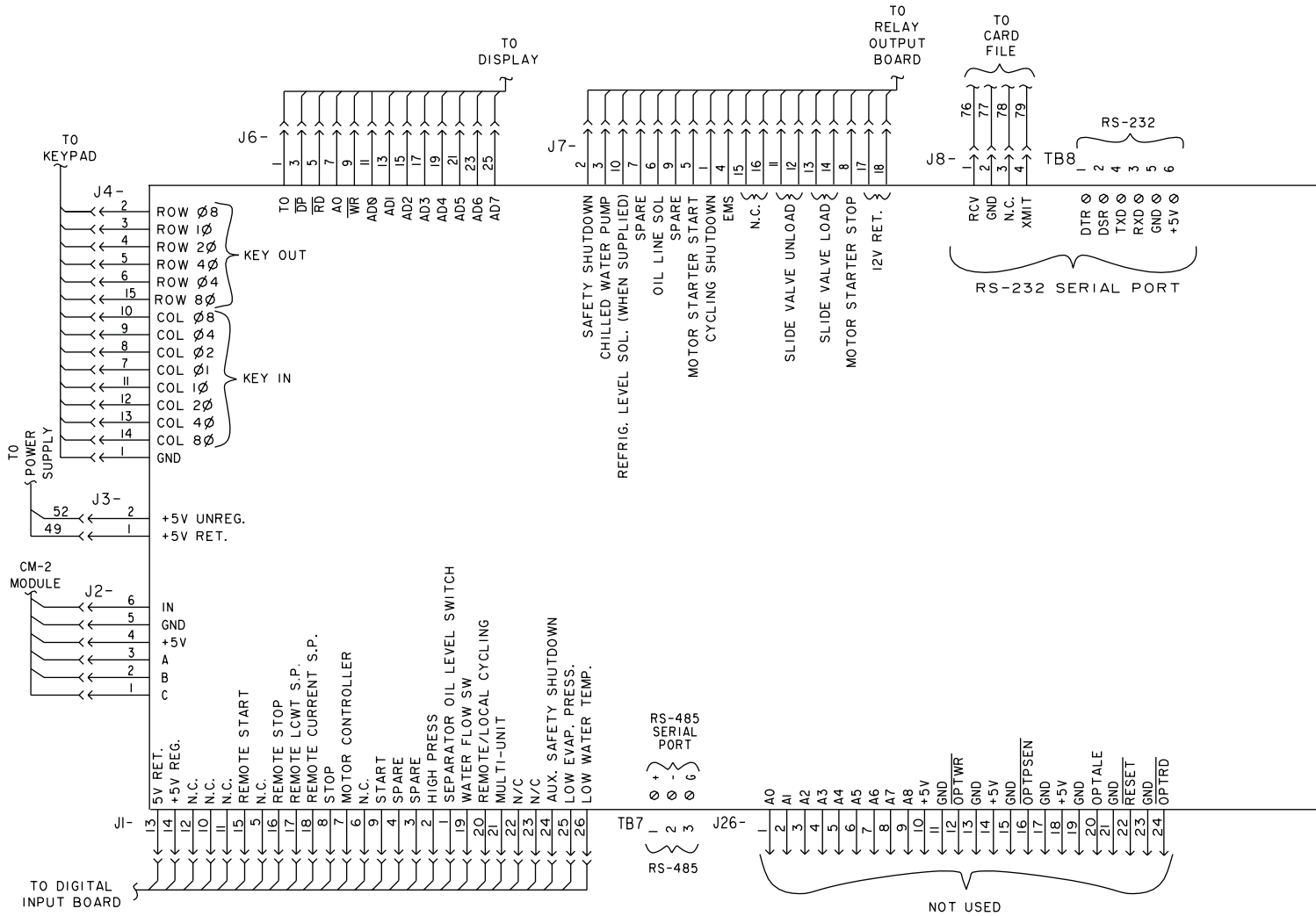

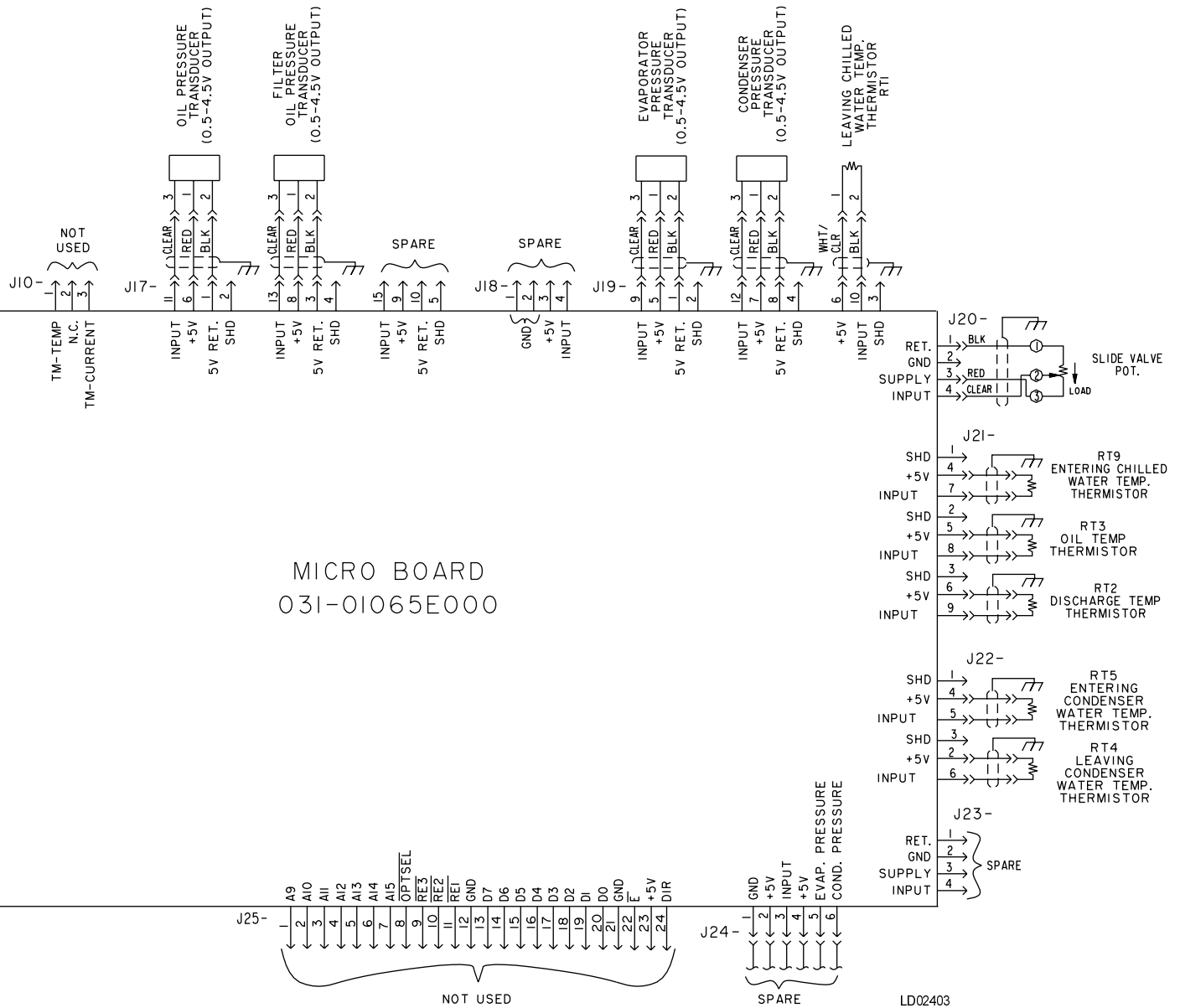

# ELEMENTARY DIAGRAM (Cont'd.)



### ELEMENTARY DIAGRAM (Cont'd.)



## LEGEND

a SOL	SLIDE VALVE-UNLOAD	LWT	LOW WATER TEMPERATURE (PROVIDED BY RTI)
b SOL	SLIDE VALVE-LOAD	MOV	METAL OXIDE VARISTOR
IHTR	500 WATT OIL HEATER	OL	MOTOR STARTER OVERLOADS
3M	CONDENSER PUMP MOTOR STARTER	SOLS	SEPARATOR OIL LEVEL SWITCH
IR	COMPRESSOR MOTOR/ HEATER CONTROL RELAY	RTI-RT9	RESISTANCE TEMPERATURE SENSING ELEMENT
ISOL	OIL LINE SOLENOID (I25-400 TR CHILLERS ONLY)	RES	RESISTOR
2SOL	REFRIGERANT LEVEL SOLENOID (WHEN SUPPLIED)	 SUPR	TRANSIENT SUPPRESSOR
ISS	DPDT 3 POSITION ROCKER SWITCH	TBI,TB3,TB6	TERMINAL BLOCK, FACTORY WIRING - 
IT	CLASS 2 POWER SUPPLY TRANSFORMER	TB2,TB4, TB5	TERMINAL BLOCK, FIELD CONNECTION - 
CM	{ SOLID STATE OVERLOAD/POWER FAULT CONTACTS (PART OF CM-2 BOARD)	-----	FIELD WIRING
CT	CURRENT TRANSFORMER	=====	FACTORY WIRING
FDTS	FAULTY DISCHARGE TEMP. SENSOR	-----	CIRCUIT BOARD OR ENCLOSURE BOUNDARY
FLA	FULL LOAD AMPS (COMPRESSOR MOTOR)	→	JACK (J1,J2,...)
FU	FUSE	⌋	PLUG (P1,P2,...)
HDT	REFRIG. HIGH DISCHARGE TEMP. (PROVIDED BY RT2)		WIRE ENTRANCE HOLE IN CONTROL PANEL
HOP	HIGH OIL PRESSURE	-----	OPTION (WHEN SUPPLIED) BY YORK.
HOT	HIGH OIL TEMPERATURE (PROVIDED BY RT3)	-----	MECHANICAL LINKAGE
HP	HIGH PRESSURE CUTOUT		SHIELDED CABLE
LEP	LOW EVAPORATOR PRESSURE (PROVIDED BY EVAP. PRESS TRANSDUCER)		METAL OXIDE VARISTOR
LOP	LOW OIL PRESSURE		
ILEP	LOW EVAPORATOR PRESSURE CUTOUT (BRINE UNITS ONLY)		
LOT	LOW OIL TEMPERATURE (PROVIDED BY RT3)		

LD02402

### NOTES:

1. This wiring diagram describes the standard electronic control scheme for use with an Electro-Mechanical Starter. For details of standard modifications (by others), refer to Product Drawing Form 160.47-PW5.
2. Field wiring to be in accordance with the National Electrical Code as well as all other applicable codes and specifications. See Product Drawing Form 160.47-PW3 for field wiring connections.
3. Numbers along the left side of diagram are line identification numbers. The numbers along the right side indicate the line number location of relay contacts. An underlined contact location signifies a normally closed contact.
4. Main control panel Class 1 field wiring terminal connection points are indicated by numbers within a rectangle, i.e. 15. Main control panel factory wiring terminal connection points are indicated by numbers within a triangle, i.e. 5. Component terminal markings are indicated by numbers within a circle, i.e. C1. Numbers adjacent to circuit lines are the circuit identification numbers.
5. To cycle on and off automatically with contacts other than those shown, install a cycling device between terminals 1 & 13 (line 27) (see Note 9). If a cycling device is installed, jumper must be removed between terminals 1 & 13.
6. Compressor motor starter with starter interlock contacts (rated 0.2 amps @ 120 volts A.C.) must be per Form 160.47-PW7. Control panel shall be grounded.
7. Units installed in Canada must have a field supplied CSA approved 30 amp disconnect switch and a 15 amp dual element fuse mounted external to control panel for 115 volt control supply.
8. To stop unit and not permit it to start again, install a stop device between terminals 1 & 8 (line 23) (see Note 9). A Remote start-stop switch may be connected to terminals 1, 7 & 8 (lines 22 and 23) (see Note 9). Remote start-stop switch (line 22) is operative only in the "remote" operating mode.
9. Device contact rating to be 5 milliamperes at 115 volts A.C.
10. Contact rating is 5A resistive @ 120 volts A.C. or 240 volts A.C.
11. To check motor rotation on initial start-up, install momentary switch between terminals 24 & 25 (line 35). Depress start switch, after approx. 30 seconds, jog motor with momentary switch. When proper rotation is obtained, replace momentary switch with jumper. Switch must have a minimum contact rating of 2 FLA, 10 LRA at 115 volts A.C.
12. Solid state motor overload (CM) is set to trip at 105% FLA. During momentary power interruption (power fault), contact also opens for 1 second.
13. For high and low voltage units, the factory supplied jumper between 1 & 53 must be removed when Electro-Mechanical starter overloads and/or safety devices are used. For high voltage (2300-4160) UL and CSA approved units only, electro-mechanical compressor motor starter overloads (normally closed) must be connected between 1 & 53.
14. Contact rating is 5 amps resistive @ 250 volts A.C. & 30 volts D.C., 2 amp inductive (0.4 PF) @ 250 volts A.C. & 30 volts D.C.
15. Each 115VAC field-connected inductive load, i.e. relay coil, motor starter coil, etc. shall have a transient suppressor wired in parallel with its coil, physically located at the coil. Spare transient suppressors and control circuit fuses are supplied in a bag attached to the top of the hinged panel.
16. Low oil pressure (LOP) safety shutdown occurs when oil pressure – evaporator pressure differential is less than 15 psi following a 3 minute bypass at compressor start.

PRESSURE – TEMPERATURE CHART							
APPLICATION		DEVICE	UNITS	OPERATING POINT			
CHILLED WATER	BRINE			ON RISE		ON FALL	
✓	✓	HDT	DEG.F/DEG.C	212/100		211/99.4	
✓	✓	HOT	DEG.F/DEG.C	170/76.7		169/76.1	
✓	✓	HOT WARNING	DEG.F/DEG.C	165/73.9		160/71.1	
✓	✓	LOP	SEE NOTE 16				
✓	✓	HP	PSIG/ kPa	CUT-OUT 270/1862	INHIBIT SLIDE VALVE LOADING * 251.3/1733	ALLOW SLIDE VALVE LOADING * 250/1724	CUT-IN 210/1448
✓		LEP (R-22)	PSIG/ kPa	CUT-IN 54.4/375	ALLOW SLIDE VALVE LOADING 57.5/396	INHIBIT SLIDE VALVE LOADING 56.2/387	CUT-OUT 54.3/374
✓		LEP (R-134 a)	PSIG/ kPa	CUT-IN 25.1/173	ALLOW SLIDE VALVE LOADING 28.0/193	INHIBIT SLIDE VALVE LOADING 27.0/186	CUT-OUT 25.0/172
	✓	ILEP	PSIG				
✓	✓	HOP	PSID/ kPa	300/2068		299/2062	
✓	✓	FDS	DEG.F/DEG.C	30.0/-1.10		29.9/-1.20	
✓		LWT	DEG.F/DEG.C	CHILLED LIQUID TEMP. SETPOINT (FOR LWT RESTART PROGRAMMING RANGE SEE FORM 160.47-01.1)		AT OR ABOVE LCWT= 40/4.4, LWT=4/2.2 BELOW THE CHILLED LIQ. TEMP. SETPOINT: WHEN THE SETPOINT IS RAISED, LWT=36/2.2 FOR 10 MINUTES, BELOW LCWT=40/4.4, LWT=36/2.2	
	✓	LWT	DEG.F/DEG.C	CHILLED LIQUID TEMP. SETPOINT (FOR LWT RESTART PROGRAMMING RANGE SEE FORM 160.47-01.1)		LWT = 4/2.2 BELOW THE CHILLED LIQ. TEMP. SETPOINT: WHEN THE SETPOINT IS RAISED, LWT=4/2.2 BELOW THE PREVIOUS CHILLED LIQ. TEMP. SETPOINT FOR 10 MINUTES	
✓	✓	CLOGGED OIL FILTER	PSID/ kPa	25.0/172		24.9/172	
✓	✓	DIRTY OIL FILTER WARNING	PSID/ kPa	20.0/138		19.9/137	

\* Function provided by condenser transducer

LD02404

# CONNECTION DIAGRAM

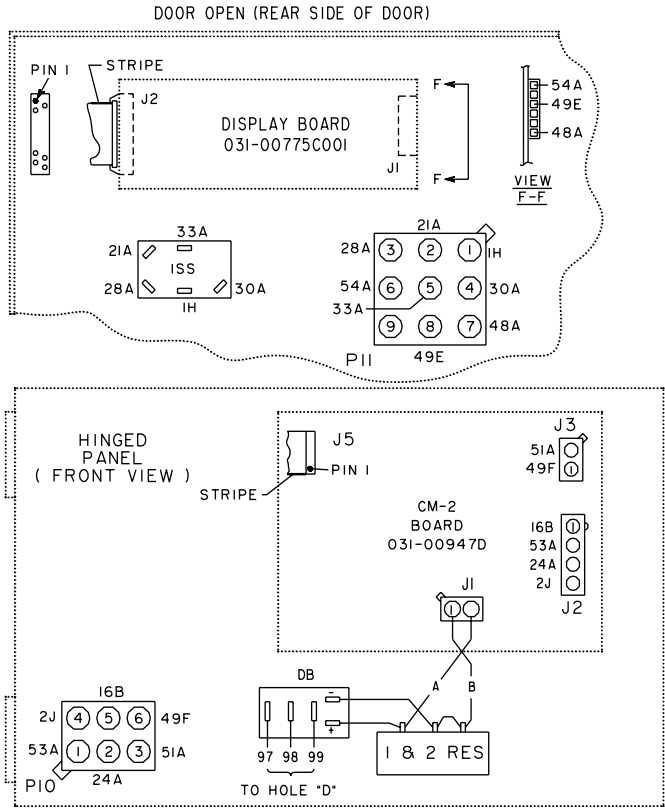

- TO REMOTE LCWT SET POINT (PWM SIGNAL) 1,19 -----
- (SEE NOTES 1,9)
- TO REMOTE CURRENT LIMIT SET POINT (PWM SIGNAL) 1,20 -----
- (SEE NOTES 1,9)
- TO CHILLED WATER PUMP CONTACTS 44,45 -----
- (SEE NOTES 14,15)
- TO REMOTE MODE READY TO START CONTACTS 26,27 -----
- (SEE NOTES 14,15)
- TO CYCLING SHUTDOWN CONTACTS 40,41 -----
- (SEE NOTES 14,15)
- TO RUN CONTACTS 35,36 -----
- (SEE NOTES 10,15)
- TO CONDENSER PUMP MOTOR STARTER 2,24 -----
- (SEE NOTE 15)
- TO CHILLED WATER PUMP INTERLOCK  
OR FLOW SWITCH 1,12 -----
- (SEE NOTE 9)
- TO SAFETY SHUTDOWN CONTACTS 42,43 -----
- (SEE NOTES 14,15)
- TO CONTACTS THAT CYCLE UNIT 1,7,8,13 -----
- (SEE NOTES 5,8,9)
- TO AUXILIARY SAFETY SHUTDOWN CONTACTS 1,31 -----
- (SEE NOTES 1,9)
- TO COMPRESSOR MOTOR STARTER 1,3,4,13,24,53 -----
- WITH CONTROL SUPPLY TRANSFORMER L,2 (GROUNDED CONDUCTOR)
- 115V, 50/60HZ., 15AMPS (SEE NOTES 6,7)
- TO MULTI-UNIT SEQUENCE CONTACTS 1,9 -----

# CONNECTION DIAGRAM

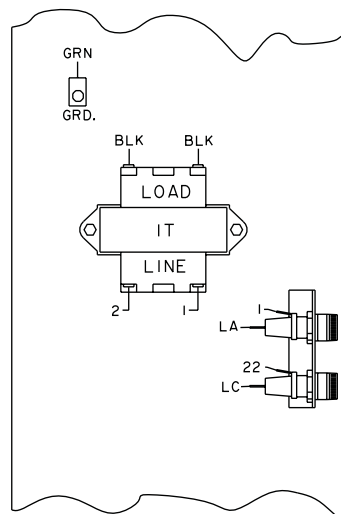
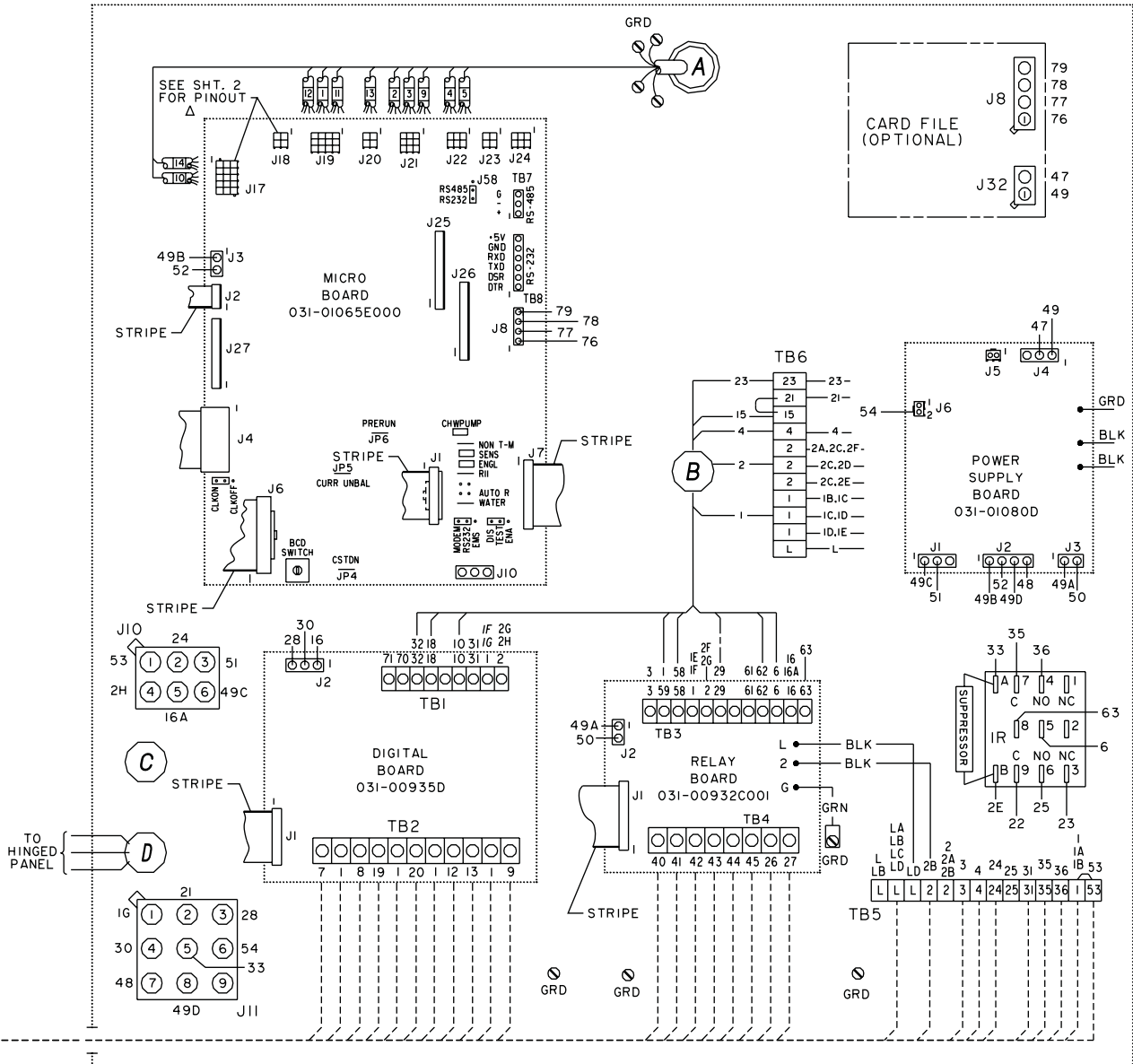

LD02405

# CONNECTION DIAGRAM (Cont'd)

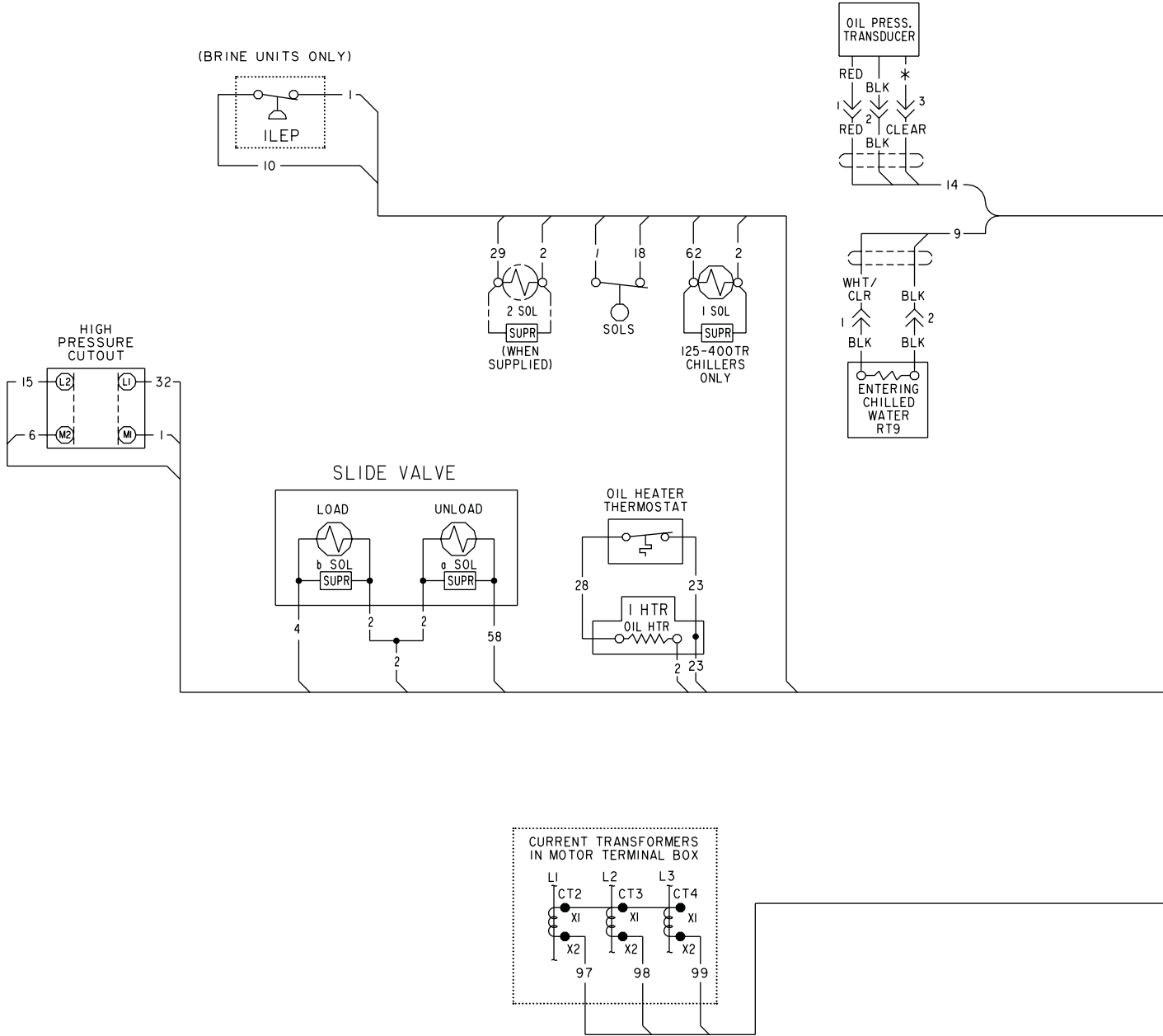

### CONNECTION DIAGRAM (Cont'd)

