



CodePak™
CODEPAK ROTARY SCREW LIQUID CHILLER

INSTALLATION INSTRUCTIONS

Supersedes: See back cover

Form 160.47-N1 (300)

COOLING
MODEL YS BA BA S0 THRU YS FC FB S5
(STYLES A, B & C)
125 THRU 675 TONS

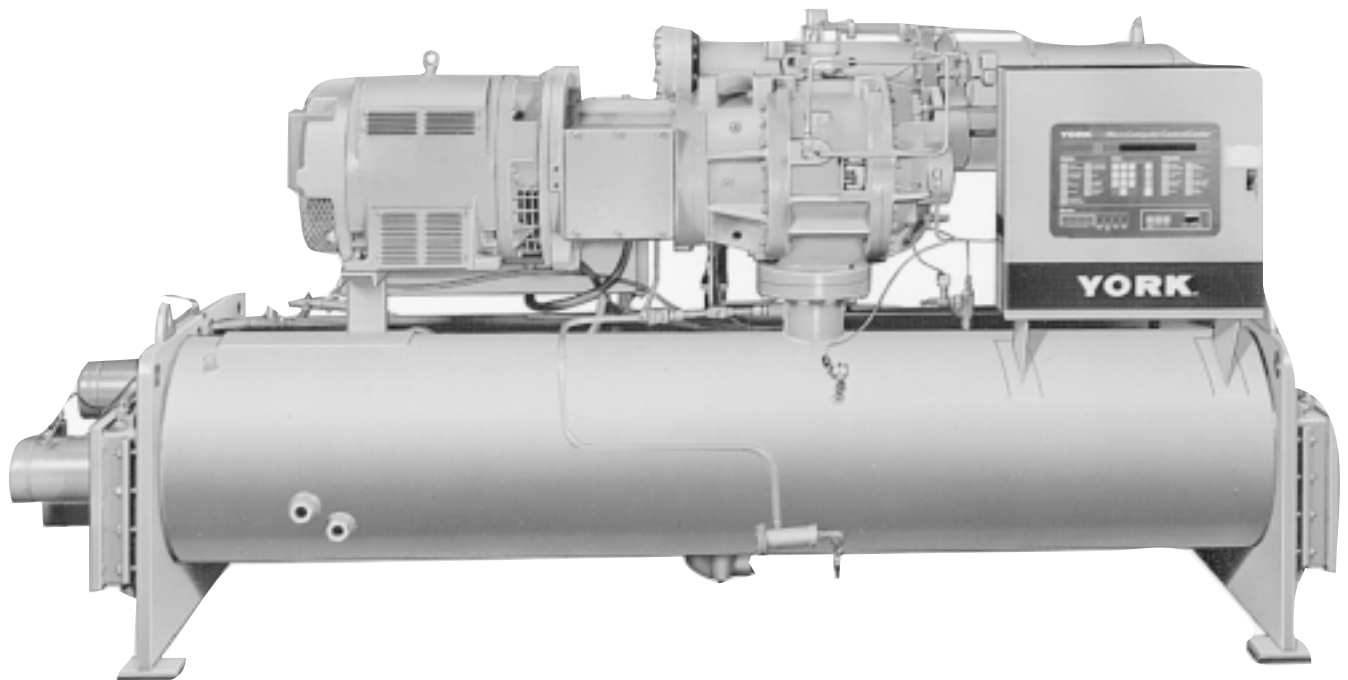

00332VIP

**REFERENCE
INSTRUCTIONS**

- 50.15-NM – SHIPPING DAMAGE CLAIMS
- SEE TABLE1 – PRODUCT DRAWINGS
- 160.47-CL1 – INSTALLATION CHECKLIST AND REQUEST FOR START-UP
- 160.47-NI.2 – FIELD ASSEMBLY OF CODEPAK

TABLE OF CONTENTS

| | |
|--|----------|
| RIGGING DATA – OVERALL DIMENSIONS & WEIGHTS | 3 |
| INTRODUCTION | 4 |
| GENERAL | 4 |
| FIELD ASSEMBLED UNITS ONLY | 4 |
| CONSTRUCTION DRAWINGS (PRODUCT DRAWINGS) | 4 |
| SHIPMENT | 4 |
| INSPECTION – DAMAGE – SHORTAGE | 5 |
| CODEPAK DATA PLATE | 6 |
| RIGGING | 6 |
| LOCATION | 7 |
| FOUNDATION | 7 |
| CLEARANCE | 6 |
| INSTALLATION | 7 |
| RIGGING UNIT TO FINAL LOCATION | 7 |
| LOCATING AND INSTALLING ISOLATION MOUNTS | 7 |
| CHECKING THE ISOLATION PAD DEFLECTION | 7 |
| CHECKING THE UNIT LEVEL | 7 |
| INSTALLING OPTIONAL SPRING ISOLATORS | 7 |
| PIPING CONNECTIONS | 8 |
| COOLER AND CONDENSER WATER PIPING | 9 |
| REFRIGERANT RELIEF PIPING | 9 |
| UNIT PIPING | 10 |
| CONTROL WIRING | 10 |
| POWER WIRING | 11 |
| INSULATION | 11 |
| INSTALLATION CHECK – REQUEST FOR START-UP SERVICE | 11 |



00333VIP

FIG. 1 – MODEL YS CODEPAK – MICROCOMPUTER CONTROL CENTER

RIGGING DATA – OVERALL DIMENSIONS & WEIGHTS

Overall dimensions and weights are shown in Product Drawings furnished with each unit in the instruction packet. Product Drawings for the unit involved are charted as follows:

| TYPE OF CODEPAK | PRODUCT DRAWING |
|-----------------|-------------------|
| Cooling – YS | Form 160.47-PA1.1 |

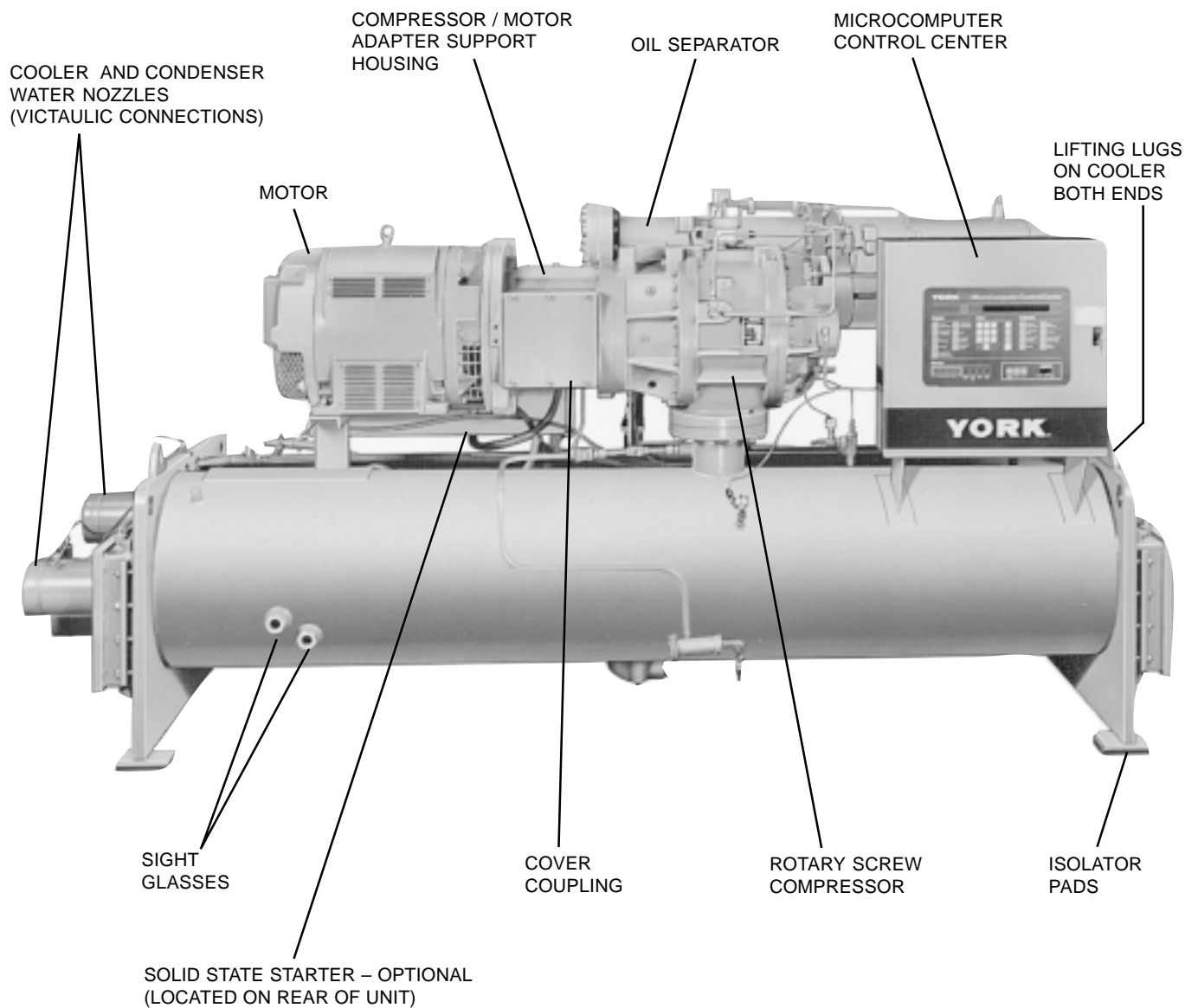

00332VIP

FIG. 2 – CODEPAK MODEL YS – FRONT VIEW OF COOLING UNIT

INTRODUCTION

GENERAL

This instruction describes the installation of a Model YS Codepak Rotary Screw Liquid Chiller. This unit is shipped as a single factory assembled, piped, wired and nitrogen or refrigerant charged package requiring a minimum of field labor to make chilled water connections, condenser water connections, refrigerant atmospheric relief connections, and electrical power connections.

CodePaks can also be shipped dismantled when required by rigging conditions, but generally it is more economical to enlarge access openings to accommodate the factory assembled unit. CodePaks shipped dismantled **MUST** be field assembled under the supervision of a YORK representative, but otherwise installation will be as described in this instruction.

FIELD ASSEMBLED UNITS ONLY

Use Form 160.47-N1.2 in conjunction with this installation instruction. This instruction will be furnished with all units that are to be field assembled. Extra copies may be ordered from the YORK Publications Distribution Center.

CONSTRUCTION DRAWINGS

Construction drawings are furnished for each job as noted in Table 1. These drawings must be carefully followed and used in conjunction with this installation instruction, to ensure proper installation of the unit. In event of any differences between drawings and this instruction, the drawings shall govern.

The services of a YORK representative will be furnished to check the installation, supervise the initial start-up and operation of all CodePaks in accordance with the contract.



The YORK Warranty will be voided if the following restrictions are not adhered to:

1. No valves or connections should be opened under any circumstances because such action will result in loss of the factory refrigerant or nitrogen charge.
2. Do not dismantle or open the CodePak for any reason except under the supervision of a YORK representative.
3. When units are shipped dismantled, notify the nearest YORK office in ample time for a YORK representative to supervise rigging the unit to its operating position and the assembly of components.
4. Do not make final power supply connections to the compressor motor or control center.
5. Do not charge the system with oil.
6. Do not attempt to start the system.
7. Do not run hot water (110°F max.) or steam through the cooler or condenser at any time.

SHIPMENT

The CodePak may be ordered and shipped in any of the following forms:

TABLE 1 – CONSTRUCTION DRAWINGS (PRODUCT DRAWINGS) ISSUED BY THE YORK DISTRICT OFFICE

| DESCRIPTION | CONTROL PANEL NO. | |
|--|--------------------------|---------------|
| | 371-01112-001 | 371-01200-003 |
| | PRODUCT DRAWING FORM NO. | |
| Dimensions and Physical Data | 160.47-PA1.1 | 160.47-PA1.1 |
| Wiring Diagram MicroComputer Control Center Solid State Starter | 160.47-PA2.1 | 160.47-PA6 |
| Wiring Diagram MicroComputer Control Center Electro-Mechanical Starter | 160.47-PA2.2 | 160.47-PA7 |
| Wiring Diagram, Solid State Starter | 160.47-PA2.5 | 160.47-PA8 |
| Field Wiring, Solid State Starter | 160.47-PA3.1 | 160.47-PA9 |
| Field Wiring, Electro-Mechanical Starter | 160.47-PA3.2 | 160.47-PA10 |
| Field Control Modifications | 160.47-PA4.1 | 160.47-PA1 1 |
| Motor Starter Specifications Electro-Mechanical Starter | 160.47-PA5.1 | 160.47-PA12 |

Form 1. – Factory Assembled Unit, Complete With Motor and Refrigerant and Oil Charges

1. The motor / compressor assembly and oil separator mounted, with all necessary interconnecting piping assembled. MicroComputer Control Center is mounted on the unit. Complete unit factory leak tested, evacuated and fully charged with Refrigerant-22.

An optional Solid State Starter can be factory mounted and wired.

2. Miscellaneous material – Four (4) vibration isolation pads (or optional spring isolators and brackets).

Form 2.– Factory Assembled (same as Form 1) except not charged with oil or refrigerant. Shipped with holding charge of nitrogen. Refrigerant shipped in 50 lb. and 125 lb. cylinders.

Form 3. – Driveline Separate From Shells – Shipped as three major assemblies. Unit first factory assembled, refrigerant piped, wired and leak tested; then dismantled for shipment. Compressor/open motor assembly removed from shells and skidded. Evaporator/condenser is not skidded. Oil separator is skidded.

All wiring integral with compressor is left on it, and all conduit is left on shell. All openings on compressor, oil separator, and shell are closed and charged with dry nitrogen (2 to 3 PSIG).

Miscellaneous packaging of control center, oil eductor filter, tubing, water temperature controls, wiring, oil, isolators, solid state starter (option), etc.; R-22 charge shipped concurrently or separately in 50 lb. and 125 lb. cylinders.

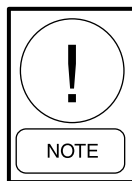

Units shipped dismantled MUST be re-assembled by, or under the supervision of a YORK Representative. (See Form 160.47-N1.2.)

Form 7. – Split Shells – Shipped as four major assemblies. Unit first factory assembled, refrigerant piped, wired and leak tested; then dismantled for shipment. Compressor / open

motor assembly removed from shells and skidded. Oil separator is skidded,

Evaporator and condenser shells are separated at tube sheets and are not skidded. Refrigerant lines between shells are flanged and capped, requiring **no** welding. **Tube sheets will require welding in field.**

All wiring integral with compressor is left on it. All wiring harnesses on shells are removed.

All openings on compressor, oil separator and shells are closed and charged with dry nitrogen (2 to 3 PSIG).

Miscellaneous packaging of control center, oil eductor filter, tubing, water temperature controls, wiring, oil, isolators, solid state starter (option), etc.; R-22 charge shipped concurrently or separately in 50 lb. and 125 lb. cylinders.

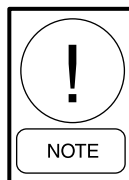

Units shipped dismantled MUST be reassembled by, or under the supervision of a YORK Representative. (See Form 160.47-N1.2.)

When more than one CodePak is involved, the major parts of each unit will be marked to prevent mixing of assemblies. (Piping and Wiring Drawings to be furnished by YORK.)

INSPECTION – DAMAGE – SHORTAGE

The unit shipment should be checked on arrival to see that all major pieces, boxes and crates are received. Each unit should be checked on the trailer or rail car when received, before unloading, for any visible signs of damage. Any damage or signs of possible damage must be reported to the transportation company immediately for their inspection.

YORK WILL NOT BE RESPONSIBLE FOR ANY DAMAGE IN SHIPMENT OR AT JOB SITE OR LOSS OF PARTS. (Refer to Shipping Damage Claims, Form 50.15-NM.)

When received at the job site all containers should be opened and contents checked against the packing list. Any material shortage should be reported to YORK immediately. (Refer to Shipping Damage Claims, Form 50.15-NM.)

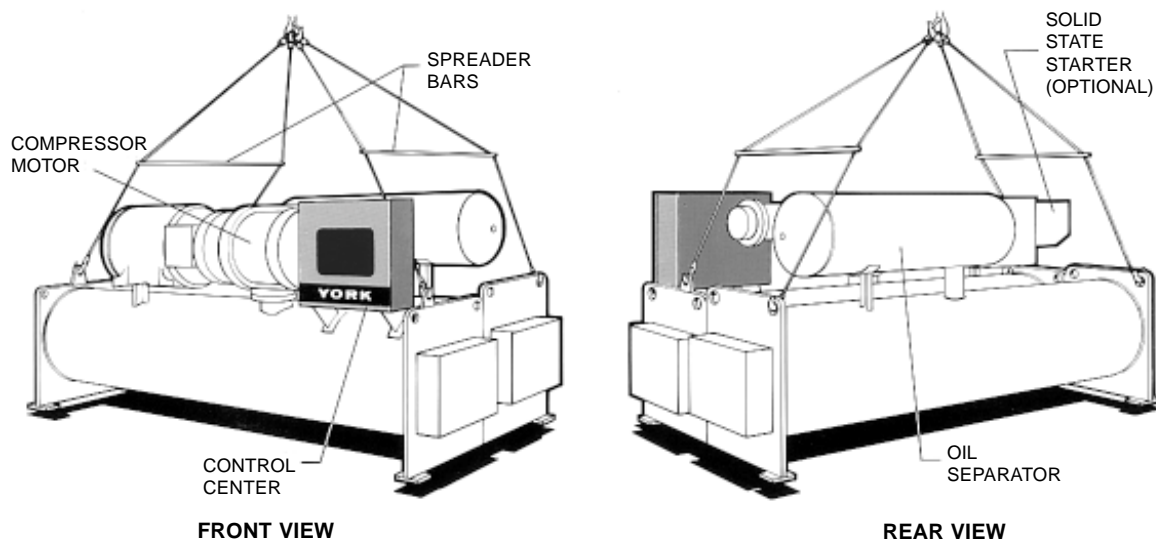

FOR LIFTING CODEPAK – Use spreader bars with four separate cables or chains. Length of lifting elements must be adequate to clear all projections.

LD05510

FIG. 3 – RIGGING

CODEPAK DATA PLATE

A unit data plate is mounted on the control center assembly of each unit, giving unit model number; design working pressure; water passes; refrigerant charge; serial numbers; and motor power characteristics and connection diagrams.

RIGGING

The complete standard CodePak is shipped without skids. (When optional skids are used it may be necessary to remove the skids so riggers skates can be used under the unit end sheets to reduce overall height.)

Each unit has four (4) lifting holes (two on each end) in the end sheets which should be used to lift the unit. (See Fig. 3.)

Care should be taken at all times during rigging and handling of the Codepak to avoid damage to the unit and its external connections. Lift only using holes shown in Fig. 3.

Do not lift the unit with slings around motor/compressor assembly or by means of eyebolts in the tapped holes of the compressor motor assembly. Do not turn a unit on its side for rigging. Do not rig vertically.

Use of Slings (See Fig. 3 for proper use of slings in rigging.)



If necessary to rig the CodePak by one end to permit lifting or dropping through a vertical passage-way, such as an elevator shaft, contact YORK factory shipping for special rigging instructions.

The rigging and operating weights and overall dimensions are given in the proper Product Drawing as referenced in Table 1, as a guide in determining the clearances required for rigging. (Add 6" to overall height for optional skidded unit.)

LOCATION

YORK Codepaks are furnished with neoprene vibration isolator mounts for basement or ground level installations. Units may be located on upper floor levels providing the floor is capable of supporting the total unit operating weight and optional spring isolators are used.

IMPORTANT

Sufficient clearance to facilitate normal service and maintenance work must be provided all around and above the unit, and particularly space provided at either end to permit cleaning or replacement of cooler and condenser tubes – see CLEARANCE on Product Drawings furnished with each job. A doorway or other sufficiently large opening properly located may be used. YS CodePak – Equipment room should be ventilated to allow adequate heat removal. Check ANSI, state, local or other codes. The chiller should be located in an indoor location where temperature range from 40°F to 110°F.

FOUNDATION

A level floor, mounting pad or foundation must be provided by others, capable of supporting the operating weight of the unit. (See Product Drawings Forms 160.47-PA1.1 or 160.47-PA1.2 for floor layout.)

CLEARANCE

Clearances should be adhered to as follows:

- 2 ft. – Rear, ends and above unit.
- Front of unit – See Product Drawings
- Tube Removal – See Product Drawings.

INSTALLATION

RIGGING UNIT TO FINAL LOCATION

Rig the unit to its final location on the floor or mounting pad, lift the unit (or shell assembly) by means of an overhead lift and lower the unit to its mounting position. (If optional shipping skids are used remove them before lowering the CodePak to its mounting position.)

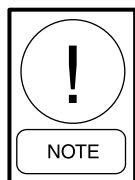

At this point units shipped dismantled should be assembled under the supervision of a YORK representative.

If cooler is to be field insulated, the insulation should be applied to the cooler before the unit is placed in position while the unit is in the lift position.

LOCATING AND INSTALLING ISOLATOR PADS (REFER TO FIG. 4)

The isolator pads should be located in accordance with the floor layout on the Dimensional Product Drawing. After the isolator pads have been placed into position on the floor, lower the CodePak onto the pads. Make sure the pads are even with the edges of the CodePak mounting feet. When the unit is in place, remove the rigging equipment and check that the chiller is level, both longitudinally and transversely. (See CHECKING THE UNIT LEVEL.)

The unit should be level within 1/4" from one end to the other end and from front to the rear. If the chiller is not level within the amount specified, lift it and place shims between the isolation pad and the CodePak tube sheets.

(Shims furnished by the installer.) Lower unit again and recheck its level.

CHECKING THE ISOLATION PAD DEFLECTION

All isolation pads should be checked for the proper deflection while checking the level of the CodePak. Each pad should be deflected approximately 0.15 inch. If an isolation pad is under deflected, shims should be placed between the unit tube sheet and the top of the pad to equally deflect all pads.

CHECKING THE UNIT LEVEL

The longitudinal alignment of the unit should be checked by placing a level on the top center of the cooler shell **under the compressor / motor** assembly. Transverse alignment should be checked by placing a level on top of the shell end sheets at each end of the CodePak.

INSTALLING OPTIONAL SPRING ISOLATORS (REFER TO FIG. 5)

To install these spring isolators first remove the bolts and nuts from the spring isolator bracket. Bolt isolator bracket to unit foot support before CodePak is located on the floor. Place the four (4) spring isolators in position in accordance with the Product Drawing Form 160.47-PA1.1. The threaded jacking screws in each isolator should be screwed out of the isolator until the extended head of the screw fits snugly into the isolator bracket hole. Then the CodePak is lowered over the jacking screws.

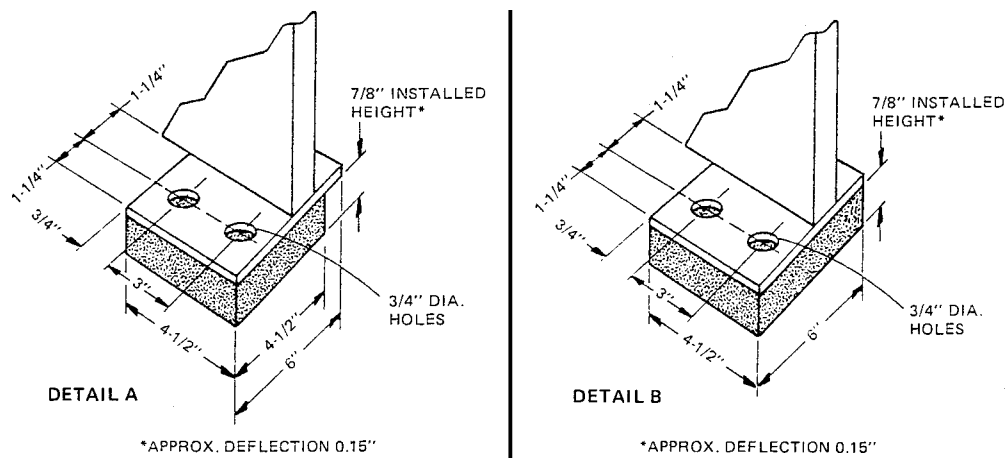

LD05511

| CODEPAK OPERATING WEIGHT | ISOLATOR PART NO. |
|-----------------------------------|-------------------|
| UP TO 16,365 LBS. SEE DETAIL A | 028-010578 |
| UP TO 28,835 LBS. SEE DETAIL B | 028-010518 |

FIG. 4 – STANDARD NEOPRENE VIBRATION ISOLATOR PAD MOUNTS

SPRING ISOLATORS (4 PER UNIT)

| SYSTEM OPERATING WEIGHT LBS. | PART NO. |
|------------------------------|---------------|
| Up to 6,865 | 029-18479-001 |
| 6,866 to 9,818 | 029-18479-002 |
| 9,819 to 12,182 | 029-18479-003 |
| 12,183 to 15,272 | 029-18479-004 |
| 15,283 to 18,272 | 029-18480-001 |
| 18,273 to 22,909 | 029-18480-002 |

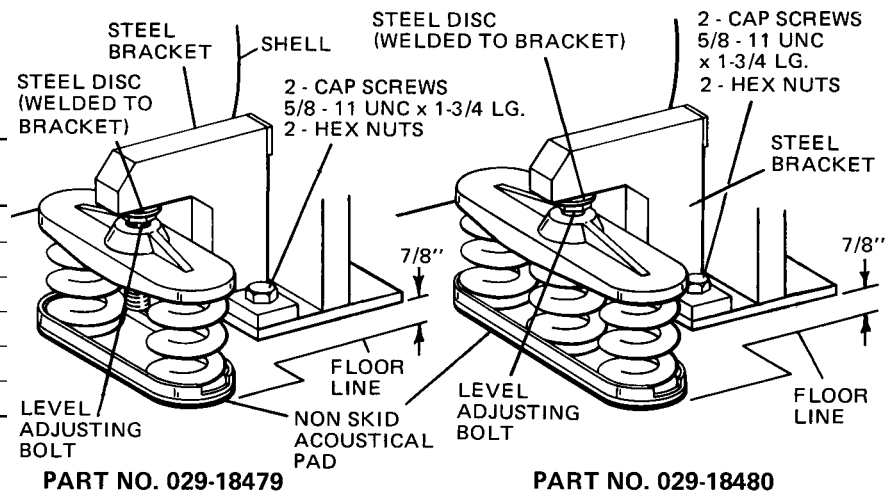

FIG. 5 – SPRING ISOLATORS

LD05512

The jacking screws should now be rotated one (1) turn at a time, in sequence, until the unit end sheets are about 7/8" off the floor or foundation, and the unit is level. Check the level of the unit both longitudinally and transversely (see Checking The Unit Level). If the jacking screws are not long enough to level unit due to an uneven or sloping floor or foundation, steel shims (grouted, if necessary) must be added beneath the isolator assemblies as necessary.

now be in correct level position, clear of the floor or foundation and without any effect from the weight of the piping. When the unit is properly supported, spring isolator deflection should be approximately 1".

After the unit is leveled, wedge and shim under each corner to solidly support the unit in this position while piping connections are being made, pipe hangers adjusted and connections checked for alignment. Then the unit is filled with water and checked for leaks. The jacking screws should now be finally adjusted until the wedges and shims can be removed. The unit should

PIPING CONNECTIONS

After the unit is leveled (and wedged in place for optional spring isolators) the piping connections may be fabricated; chilled water, condenser water and refrigerant relief. The piping should be arranged with offsets for flexibility, and adequately supported and braced independently of the unit to avoid strain on the unit and vibration transmission. Hangers must allow for alignment of pipe. Isolators (by others) in the piping and hangers are highly desirable, and may be required by specifications, in order to effectively utilize the vi-

bration isolation characteristics of the vibration isolation mounts of the unit.

Check for piping alignment – Upon completion of piping, a connection in each line as close to the unit as possible should be opened, by removing the flange bolts or coupling and checked for piping alignment. If any of the bolts are bound in their holes, or if the connection springs out of alignment, the misalignment must be corrected by properly supporting the piping or by applying heat to anneal the pipe.

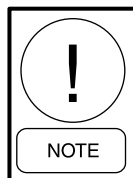

In some systems, it may be necessary to weld chilled water piping directly to the water pipe nozzles. Since chiller water temperature sensor wells are often in close proximity to these connection points, sensors in the wells may often see temperatures of several hundred degrees. We have reason to believe that some potential exists for damaging these sensors from the transferred heat. Any damage will most likely show up as error in the sensor.

It is advisable to remove the sensors from the wells during the welding process as a precautionary measure. If the sensor is removed, assure that it bottoms out when it is placed back in the well.

This same precaution should also be observed whenever condenser water temperature sensors are present in the chiller system and condenser water piping is to be welded to the chiller.

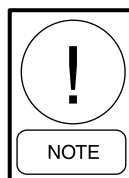

If the piping is annealed to relieve stress, the inside of the pipe must be cleaned of scale before it is finally bolted in place.

COOLER AND CONDENSER WATER PIPING

The cooler and condenser liquid heads of Codepak units have nozzles which are grooved, suitable for welding 150 PSIG DWP flanges or the use of Victaulic couplings.

The nozzles and water pass arrangements are furnished in accordance with the job requirements (see Product Drawings as referenced in Table 1) furnished with the job. Standard units are designed for 150 PSIG DWP on the water side. If job requirements are for greater than 150 PSIG DWP, check the unit data plate to determine if the CodePak has provisions for the required DWP before applying pressure to cooler or condenser.

Cooling Units – Chilled Water (Refer to Fig. 6.)

Chilled water must leave the cooler through the connection marked “Liquid Outlet.” Cooling water must enter the condenser through the connection marked “Liquid Inlet.”

Foreign objects which could lodge in, or block flow through, the cooler and condenser tubes must be kept out of the water circuit. All water piping must be cleaned or flushed before being connected to the CodePak, pumps, or other equipment.

Permanent strainers (by others) are required in both the cooler and condenser water circuits to protect the CodePak as well as the pumps, tower spray nozzles, chilled water coils and controls, etc. The strainer, meeting YORK specifications should be installed in the entering chilled water line, directly up-stream of the CodePak.

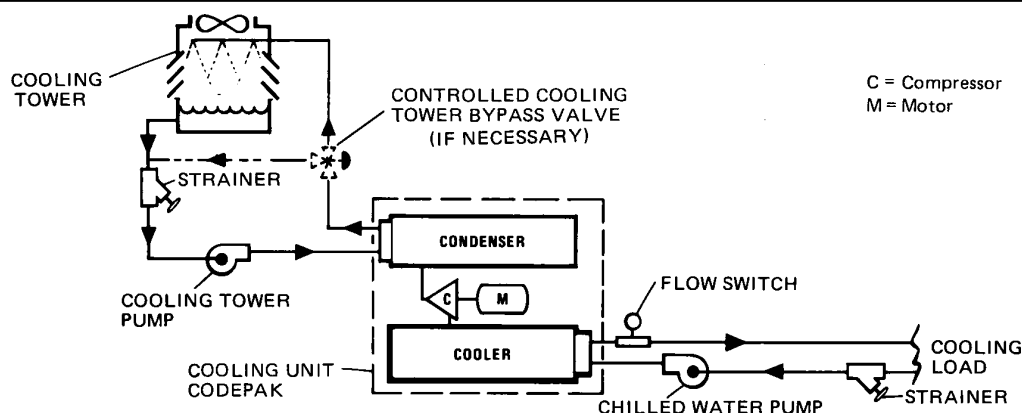

FIG. 6 – SCHEMATIC OF A TYPICAL PIPING ARRANGEMENT FOR COOLING ONLY CODEPAKS

Water piping circuits should be arranged so that the pumps discharge through the CodePak, and should be controlled as necessary to maintain essentially constant chilled and condenser water flows through the unit at all load conditions.

If pumps discharge through the CodePak, the strainer may be located upstream from pumps to protect both pump and CodePak. (Piping between strainer, pump and CodePak must be very carefully cleaned before startup.) If pumps are remotely installed from CodePak, strainers should be located directly upstream of the CodePak.

Cooling Units – Condenser Water Circuit (Refer to Fig. 6.)

For proper operation of the unit, condenser refrigerant pressure must be maintained above cooler pressure. If operating conditions will fulfill this requirement, no attempt should be made to control condenser water temperature by means of automatic valves, cycling of the cooling tower fan or other means, since CodePaks are designed to function satisfactorily and efficiently when condenser water is allowed to seek its own temperature level at reduced loads and off-peak seasons of the year. However, if entering condenser water temperature can go below the required minimum, (refer to 160.47-O1, Fig. 4) condenser water temperature must be maintained equal to or slightly higher than the required minimum. Refer to Fig. 6 for typical water piping schematic for cooling CodePak.

Stop Valves

Stop valves may be provided (by others) in the cooler and condenser water piping adjacent to the unit to facilitate maintenance. Pressure taps should be provided (by others) in the piping as close to the unit as possible to facilitate operating checks.

Flow Switches (Field Installed)

A flow switch or pressure differential control in the chilled water line(s) adjacent to the unit is an accessory furnished for connection to the control center. If a flow switch is used, it must be directly in series with the CodePak and sensing only water flow through the CodePak. The differential switch must sense pressure drop across the unit.

Drain and Vent Valves

Drain and vent valves (by others) should be installed in the connections provided in the cooler and condenser liquid heads. These connections may be piped to drain if desired.

Checking Piping Circuits and Venting Air

After the water piping is completed, but before any water box insulation is applied, tighten and torque (to maintain between 30 and 60 ft. lbs.) the nuts on the liquid head flanges. Gasket shrinkage and handling during transit cause nuts to loosen. If water pressure is applied before this is done, the gaskets may be damaged and have to be replaced. Fill the chilled and condenser water circuits, operate the pumps manually and carefully check the cooler and condenser water heads and piping for leaks. Repair leaks as necessary.

Before initial operation of the unit both water circuits should be thoroughly vented of all air at the high points.

REFRIGERANT RELIEF PIPING

Each unit is equipped with relief device(s) on the cooler, condenser and oil separator for the purpose of quickly relieving excess pressure of the refrigerant charge to the atmosphere as a safety precaution in case of an emergency. The relief device is furnished in accordance with ASHRAE-15 and is set to relieve at 300 PSIG. (Larger relief valve on oil separator is set at 350 PSIG.)

Refrigerant relief vent piping (by others), from the relief valves to the outside of the building, is required by code and should be installed on all CodePaks. The vent line(s) should be designed in accordance with ASHRAE-15 or local code(s).

UNIT PIPING

Compressor lubricant piping and system R-22 external piping are factory installed on all units shipped assembled. On units shipped dismantled, the following piping should be completed under the supervision of the YORK representative; the lubricant piping; system oil return using material furnished. See Form 160.47-N1.2

CONTROL WIRING (SEE TABLE 1 FOR PROPER WIRING DIAGRAM)

On units shipped disassembled, after installation of the control center, control wiring must be completed between unit components and control center or solid state starter when used, using wiring harness furnished.

Field wiring connections for commonly encountered control modifications (by others), if required, are shown on Wiring Diagram listed in Table 1.

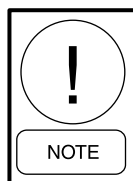

No deviations in unit wiring from that shown on drawings furnished shall be made without prior approval of the YORK Representative.

POWER WIRING (SEE TABLE 1 FOR PROPER WIRING DIAGRAM)

CodePak with Electro-Mechanical Starter

A 115 volt – single phase – 60 or 50 Hertz power supply of 15 amperes must be furnished to the control center, from the optional control transformer (1-1/2 KVA required) included with the compressor motor starter. **DO NOT** make final power connections to control center until approved by YORK representative.

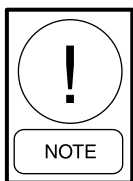

Remote Electro-Mechanical starters for the CodePak must be furnished in accordance with YORK Standard R-1079.

Each CodePak unit is furnished for a specific electrical power supply as stamped on the Unit Data Plate, which also details the motor connection diagrams.

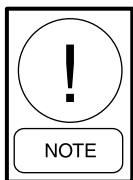

To ensure proper motor rotation the starter power input and starter to motor connections must be checked with a phase sequence indicator in the presence of the YORK representative.

IMPORTANT

DO NOT cut wires to final length or make final connections to motor terminals or starter power input terminals until approved by the YORK representative.

YS Motors (Electro-Mechanical Starter)

Fig. 7 shows the power wiring hook-up for YS CodePak Motor Connections. (Refer to Wiring Labels in Motor Terminal Box for hook-up to suit motor voltage and amperage.)

Motor leads are furnished with a crimp type connection having a clearance hole for a 3/8" bolt, motor terminals lugs are not furnished.

CodePak With Solid State Starter (Optional)

A CodePak equipped with a Solid State Starter, does not require wiring to the compressor motor. The motor power wiring is factory connected to the Solid State Starter (or an optional factory installed disconnect switch). All wiring to the control panel is completed by the factory. A control transformer is furnished with the Solid State Starter.

INSULATION (SEE PRODUCT DRAWING FORM 160.47-PA1.1)

Insulation of the type specified for the job, or minimum thickness to prevent sweating of 30°F surfaces (water chill application), should be furnished (by others) and applied to the cooler shell, end sheets, liquid feed line to flow chamber, compressor suction connection, and cooler liquid heads and connections. The liquid head flange insulation must be removable, to allow head removal for tube maintenance. Details of areas to be insulated are given on the Product Drawings.

Units can be furnished factory anti-sweat insulated on order at additional cost. This includes all low temperature surfaces except the two (2) cooler liquid heads.

IMPORTANT

DO NOT field insulate until the unit has been leak tested under the supervision of the YORK representative.

INSTALLATION CHECK – REQUEST FOR START-UP SERVICE

After the unit is installed, piped and wired as described in this Instruction, but before any attempt is made to start the unit, the YORK District Office should be advised so that the start-up service, included in the contract price, can be scheduled. Notification to the YORK office should be by means of Installation Check List and Request, Form 160.47-CL1, in triplicate.

The services of a YORK representative will be furnished to check the installation and supervise the initial start-up and operation on all CodePaks installed within the Continental United States.

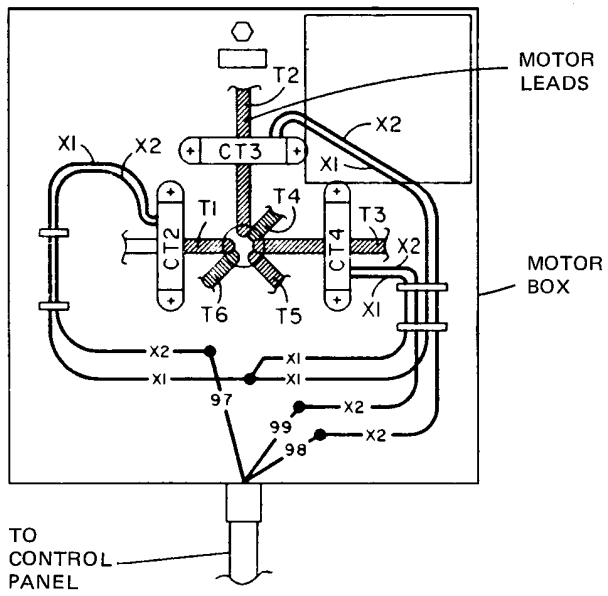

LOW VOLTAGE (6 LEAD MOTOR)
(200V – 600V)

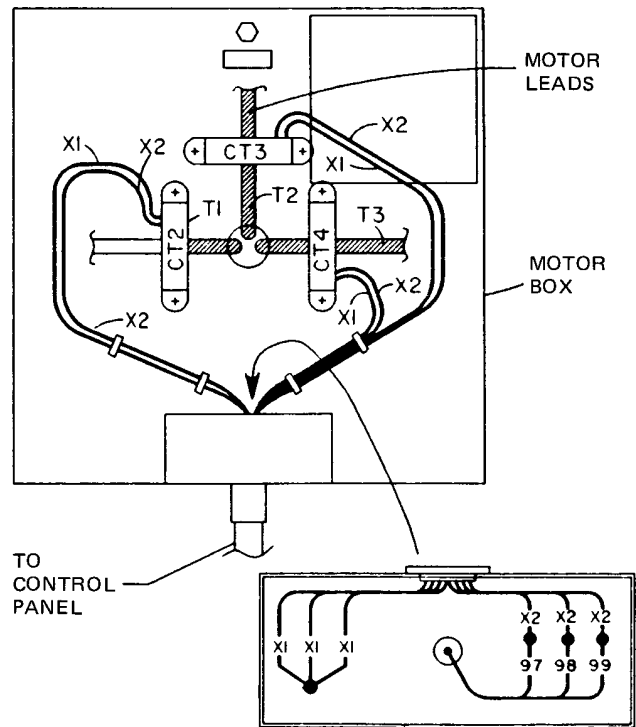

HIGH VOLTAGE (3 LEAD MOTOR)
(2300V – 4160V)

LD05514

FIG. 7 – YS CODEPAK MOTOR CONNECTIONS (ELECTRO-MECHANICAL STARTER APPLICATION)

