

MICROCOMPUTER CONTROL CENTER



- SECTION 1
- SECTION 2
- SECTION 3
- SECTION 4
- SECTION 5
- SECTION 6
- SECTION 7

REFERENCE LITERATURE

FORMS	DESCRIPTION
160.65-PA2.1	WIRING DIAGRAM
160.65-PA3.2	FIELD WIRING
160.65-PA4.1	FIELD MODIFICATIONS
160.65-O1	OPERATING AND MAINTENANCE

TABLE OF CONTENTS

SECTION 1

Operation/Start-Up	3-11	Annunciator Display	8
Introduction	3	Shutdown Record Display	9
Keys and Functions	4	Freeze Display	9
Operating Display	5	Security Display	10
Adjustable Setpoints Display	6	Auto Cycle Display	10
To Change Adjustable Setpoint	7	Cycle Flow Inputs	11
How to Determine Adjustable Setpoints	7	Switches/Shutdowns and Inputs	11
Fixed Setpoints Display	8	Cycling	11
Fixed Setpoints	8		

SECTION 2

How The Microprocessor Center Works	12
---	----

SECTION 3

Service	13-24	Calibration Check of Liquid Level Sensor (LT-106)	20-22
Single Board Computer PCB Diagram & Adjustment Locations	14	SV Pos Potentiometer Replacement & Adjustment	22
Eprom Replacement	15	Volumizer Potentiometer Replacement & Adjustment	22-23
Output Fuse Replacement (1 FU & 2 FU)	15	Temperature and/or Pressure Adjustment	25
Pressure Transducers	15-18	Checking Motor Rotation	25
Testing	15	Battery Backup	25
Removal/Replacement	18	Liquid Crystal Displays Adjustment	25
Tools Required	18		
Installation	18		
Temperature Sensors	18		
Liquid Level Actuator Valve & Level Transmitter Operation	20		

SECTION 4

Compressor Motor Starter, (CT's) Control Transformer and Power Factor Capacitors	25
---	----

SECTION 5

Troubleshooting, Power Dips & Power Failures & Chiller Start Up Flow Chart	26-33	Troubleshooting Control System (Reference Wiring Diagrams)	27
Troubleshooting the MicroComputer Control Center	26	Misc. Service Notes on SBC	27
Abnormal Operation and Analysis and Correction	26	Troubleshooting Charts	28-30
Maintenance	27	Power Dip Flow Chart	31
		Power Failure Chart	31
		Unit Start Up Flow Chart	32-35

SECTION 6

Display Screens	36-38
-----------------------	-------

SECTION 7

Telecommunications	39-42
--------------------------	-------

SECTION 1 OPERATION & START-UP

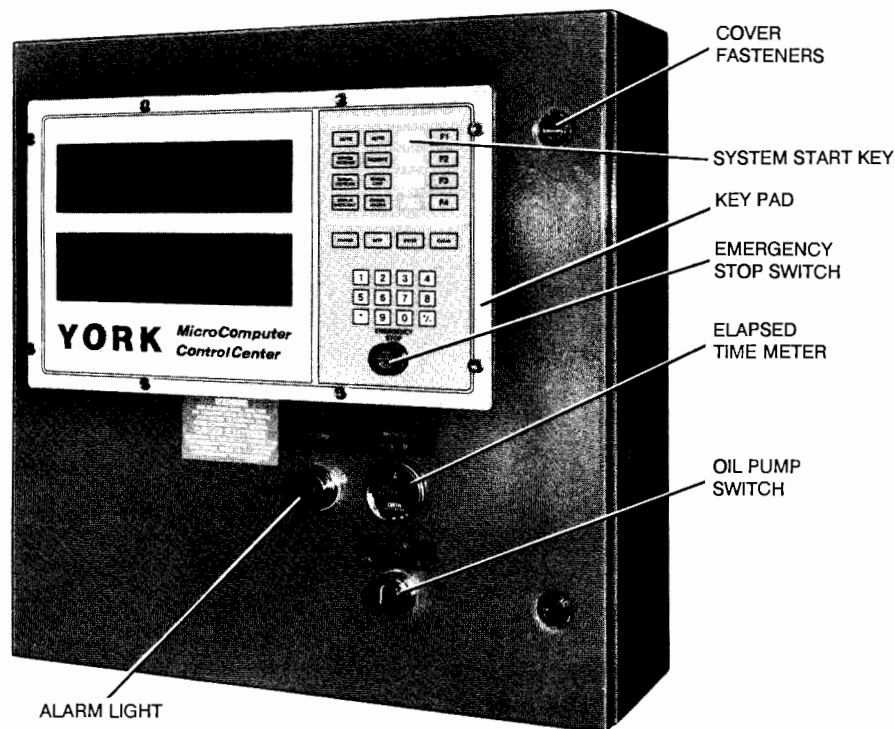

FIG. 1 – MICROCOMPUTER CONTROL CENTER FOR ROTARY SCREW CHILLER

INTRODUCTION

This instruction covers the operation and startup of the YORK Rotary Screw Chiller, 1000 through 1250 tons, MicroComputer Control Center and its association with the operation of the compressor lubrication system, the oil separator system, and the hydraulic system.

The instruction also includes complete information about the chiller system which includes cooler and condenser temperature and pressure controls.

The information in this section of the manual provides the logical step-by-step instructions to properly start-up and operate the YORK Codepak Rotary Screw Chiller Unit.

THE INFORMATION CONTAINED IN THIS INSTRUCTION MUST BE READ AND UNDERSTOOD BEFORE ATTEMPTING TO START OR OPERATE THE UNIT.

The YORK Codepak Rotary Screw Chiller is controlled by a state-of-the-art MicroComputer Control Center. This control center continuously monitors the chiller's condition and operation. The MicroComputer also directs instructions to the various chiller unit subsystems.

The MicroComputer Control Center has a membrane switch keyboard. Pressing the keyboard in the area YORK APPLIED SYSTEMS

outlined as a key will cause that function to be recognized by the microprocessor. The keyboard has 32 membrane type keys.

In addition to the keyboard, there is an emergency stop button. Pushing the emergency stop will bypass the computer and remove all power from the outputs.

This will shut down the compressor motor and all high voltage to the compressor auxiliary systems such as the oil pump and liquid injection solenoid. THE EMERGENCY SHUTDOWN IS FOR EMERGENCY SHUTDOWN SITUATIONS ONLY and MUST NOT BE USED TO ROUTINELY SHUT OFF THE COMPRESSOR.

HAZARD OF ELECTRIC SHOCK

WARNING – OPEN ALL DISCONNECTS BEFORE SERVICING EQUIPMENT.

The microprocessor continuously monitors the state of the battery which maintains setpoints and various other data. If the battery voltage is low, the message "LOW BATTERY" will flash in the lower right hand corner of the bottom display.

The MicroComputer Control Center hardware contains an output watch-dog circuit. If the microprocessor should fail, this circuit will disable (turn off) all outputs.

KEYS AND KEY FUNCTIONS

NOTE: The MicroComputer Control Center will automatically return to the MAIN display after 60 seconds of keyboard nonactivity.

The **CHANGE** key rotates the dual display screen through seven display modes. The **CHANGE** key is also used to change the status of various setpoints.

The **STEP** key steps or moves a set of flashing brackets through the variable setpoints on the Adjustable setpoints display, the Auto-cycle display, the Security display and the Setback display. The setpoint enclosed within the flashing brackets may be changed or updated. The **STEP** key is also used when the annunciator display is selected to step through the annunciator's four information displays.

*NOTE: The * key is used to step or move the flashing brackets, described above, backwards.*

The **ENTER** key is used to enter new setpoint limits.

The **CLEAR** key will reset an alarm or cutout indication on the annunciator screen and will clear the microprocessor to allow continued operation or restarting if all conditions have returned to normal and no other control lockouts are in force.

The **NUMERIC KEYPAD** is used to introduce new setpoint limits.

The **RUN**, **STOP**, and **REMOTE START** keys control the starting and stopping of the compressor unit.

The **ALARM SILENCE** key will de-energize the alarm light.

The **AUTO**, **REMOTE** and **MANUAL** keys control the operation of the compressor slide valve and moveable slide stop.

The **F1** function key will return the operator to the main operating display. This function may be invoked at any time, even during setpoint entry.

The **F2** function key will call up the Security display.

NOTE: Press the F2 key, as prompted by the display, to return to the previously selected display.

The **F4** function key will call up the Auto Cycle display.

NOTE: To exit the Auto Cycle display, press the F1 key as prompted by the display.

The **DISPLAY BACKLIGHT** key will toggle the dual LCD display backlights on and off. A preset delay will shut off the backlight after ten minutes elapsed time.

The MicroComputer Control Center has two liquid crystal displays in an 8 line by 40 character format, for a total of 320 characters. There are 9 different display modes. When power is first applied to the control panel, the unit

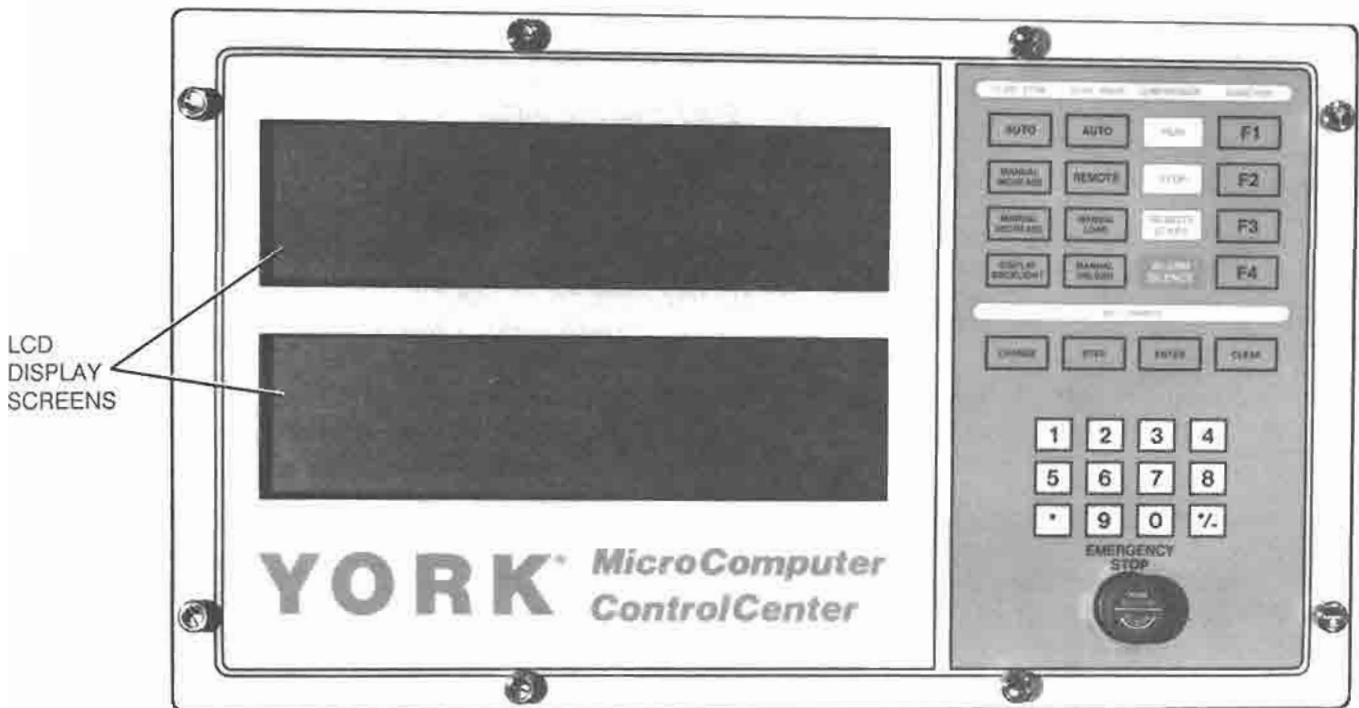

FIG. 2 – MICROCOMPUTER CONTROL CENTER MEMBRANE KEYBOARD

will be in the MAIN display mode. To change to a different display mode, press the **CHANGE** key. The display modes in their order of rotation are:

1. Main display
2. Operating display
3. Adjustable Setpoints display
4. Fixed Setpoints display
5. Annunciator display
6. Shutdown Record display
7. Freeze display

-
- [F2] Security display
 - [F4] Auto Cycle display
-

NOTE: On initial powering of the MicroComputer Control Center, and any time power has been removed from the control center, only the Main, Operating, Setpoints, Annunciator, and Shutdown displays will display information. The freeze display will appear as a dark screen. The Freeze display will only be present after a compressor unit cutout.

OPERATING DISPLAY*
(Refer to DISPLAY SCREENS page 34)

OPERATING DISPLAY: Thu 10-05-89 15:33:36				
Suction Disch Oil Filter Compressor				
74.5 g	180 g	170 g	01PSID	MAN Mode
44° F	140° F	135° F	RUNNING	
V Ratio S V Pos Pump %FLA Sep 132°F				
1.8	090%	OFF	089%	HTR off
Auto D	Auto L	FORCED UNLD		ALARM
Liq Temp = + 44°F Liq Level = 50% LOW BATTERY				

* Display for illustrative purposes only.

The Operating display is continuously updated and provides a variety of information in regard to the current status of the compressor's condition and performance.

The information furnished by the Operating display is as follows:

The DAY, DATE, and TIME are displayed at the top right of the display.

NOTE: To set day, date, and time; see **TO CHANGE THE ADJUSTABLE SETPOINTS**

SUCTION – Suction Pressure and Temperature are measured at the compressor inlet and are, respectively, displayed in pounds per square inch gauge (g) and degrees Fahrenheit.

DISCH – Discharge Pressure and Temperature are measured at the compressor outlet and are, respectively, displayed in pounds per square inch gauge (g) and degrees Fahrenheit.

OIL – Oil Pressure and Temperature are measured prior to entering the compressor and are, respectively, displayed in pounds per square inch gauge (g) and degrees Fahrenheit.

COMPRESSOR – Compressor displays the status of the compressor unit. The mode of operation will be indicated as either manual (MAN MODE) when the RUN key has been pressed, automatic (AUTO MODE) when Auto Cycle has been activated, remote (RMT MODE) when the REMOTE key has been pressed, or off (OFF MODE).

V RATIO – Volume Ratio is the ratio selected by the MicroComputer to provide the highest efficiency at any given suction and discharge pressure condition. Immediately below this, an information space has been provided to indicate whether V ratio is in the automatic (AUTO) or the manual (MAN) mode. The MicroComputer will control this function only in the automatic mode. To the right of the mode indicator, two other messages may appear:

- I - Indicates V Ratio increase.
- D - Indicates V Ratio decrease.

SV POS – Slide valve position is displayed as a percentage. This percentage reflects the mechanical position of the slide valve and does not reflect the percentage of full load operation. Immediately below this information, space has been provided to indicate whether SV Pos is in the automatic (AUTO), manual (MAN), or remote (RMT) mode. The MicroComputer will control this function in the automatic mode. To the right of the mode indicator, two other messages may appear:

- L - Indicates Slide Valve loading.
- U - Indicates Slide Valve unloading.

PUMP – Pump displays the current status of the oil pump. The display will read ON or OFF whenever the HAND-OFF-AUTO switch is selected to AUTO and the compressor is running.

SECTION
1

% FLA — Percent Full Load Amps displays the percentage of the drive motor full load amperage rating that the motor is currently using.

SEP — Separator displays the oil separator temperature in degrees Fahrenheit.

HTR — Heater displays the condition of the oil separator heater(s), indicating ON or OFF.

ALARM/CUTOUT — An Alarm or Cutout message indicates an Alarm or Cutout setpoint has been reached, or exceeded. Rotate the display mode to the Annunciator display for details. In the event of a cutout, rotate to the Freeze display for further details.

FORCED UNLD — A Forced Unload message indicates that the percentage of motor full load amps has exceeded the maximum limit and the MicroComputer is unloading the compressor until the percentage FLA falls back to normal limits.

RECYCLE DELAY — A Recycle Delay message indicates that the compressor has shut down within the time delay setpoint period. The Recycle Delay will prevent the compressor from starting until the 30 min. delay time expires and is intended to prevent damage to the compressor motor from successive restarts. During Recycle Delay, the MicroCompter will alternately flash "RECYCLE DELAY" and the remaining delay time in minutes.

CAUTION: If the [RUN] key is pushed while the unit is in Recycle Delay, the compressor will start at the end of the delay period.

LIQ. TEMP. — Displays the leaving chilled water or brine temperature in degrees F as the application requires.

LIQ. LEVEL — Displays the level of refrigerant in the subcooler as a % value.

ADJUSTABLE SETPOINTS DISPLAY*
(Refer to DISPLAY SCREENS page 34)

ADJUSTABLE SETPOINTS: ID = [33] [10-01-89]	
Cap. Control — [45° F]	Thu [15:33:36]
Lo Suct Cutout-[57.7 g]	Baud—[2400]
Lo Suct Alarm—[55.0 g]	
Hi Disch Cutout-[225 g] Flow [NC]	
Hi Disch Alarm—[215 g]	
M.L.C.1 Stop Load-[095%] CT Factor-[078]	
M.L.C.2 Force Unld[100%] Recy.Delay-[30]	

* Display for illustrative purposes only.

The Adjustable Setpoints display lists the adjustable setpoints which define the limits of the compressor package operation. When these limits are reached, or exceeded, an alarm or compressor shutdown will occur.

The information furnished by the Adjustable Setpoints display is as follows:

CAPACITY CONTROL — Control setpoint relative to leaving water temperature in degrees F.

LIQ. TEMP. — The Liq. Temp. setpoint, reported in degrees F controls the loading and unloading of the compressor when SV POS is in the automatic (AUTO) mode.

LO SUCT CUTOUT — The Low Suction Pressure Cutout, reported in pounds per square inch gauge (g) will shut down the compressor if the suction pressure drops to this limit, or lower, for one second or longer. This is fixed, not adjustable.

LO SUCT ALARM — The Low Suction Pressure Alarm, reported in pounds per square inch gauge (g) will trigger a pre-alarm if the suction pressure drops to this limit, or lower.

HI DISCH CUTOUT — The High Discharge Pressure Cut-out, reported in pounds per square inch gauge (g), will shut down the compressor if the discharge pressure equals, or exceeds, this setpoint. This cutout is fixed-not adjustable.

HI DISCH ALARM — The High Discharge Pressure Alarm, reported in pounds per square inch gauge (g) will trigger a pre-alarm if the discharge pressure equals, or exceeds, this setpoint.

M.L.C. 1 STOP LOAD — The Motor Load Control Stop Load, reported as a percentage of the motor full load amps (FLA), will prevent the compressor slide valve from loading when the setpoint is equaled, or exceeded.

M.L.C. 2 FORCE UNLD — The motor Load control Force Unload, reported as a percentage of the motor full load amps (FLA), will force the compressor to unload until the motor full load amps (FLA) fall within 1% of the setpoint, or lower.

ID — The ID number is a programmable identification code used in telecommunications to access a specific compressor.

DATE — The date displays the current date in the following format: Month- Day- Year.

DAY — Day will display the current day of the week.

TIME – The Time displays the current time in the following format: Hours:Minutes:Seconds. The time is in 24:00:00 hour clock format.

D.B. = ± Allowable deadband of the liq. temp. programmable from 1°F to 10°F.

P.B. = ± Proportional Band Toggles in 2, 5, or 10% values.

Position – Refrigerant Level Set Point in %.

Dead Band – Refrigerant Level Actuator Dead Band adjustable from 1% to 10%.

Proband – Refrigerant Level Actuator Proportional Band Toggles at 20, 50, or 100%.

Cap. Control – Shows the chilled liquid set point in °F.

BAUD – Shows the baud rate of the RS422 communication ports 1 and 2. Both ports are configured as follows: word = 8 bit, parity = none or even, stop = 1 bit. The communications ports are programmable from 300 to 19200 baud.

Lo Liq. Temp. Cutout – The leaving chilled water temperature, expressed in degrees F, will shut down the compressor if it drops to this limit or lower.

Lo Liq. Temp. Alarm – The leaving chilled water temperature, expressed in degrees F, will trigger a prealarm if the temperature drops to this limit or lower.

CT FACTOR – The Current Transformer Factor records the proper current transformer factor to match the compressor motor FLA rating to the current transformer primary rating. The CTF factor is programmable and its correct value is determined by the following formula:

$$CTF = \frac{1024 \times FLA \text{ (Full Load Amps)}}{10 \times CT \text{ (Current Transformer Primary Amps)}}$$

EXAMPLE:

$$\begin{aligned} FLA &= 230 \text{ Amps} \\ CT &= 300 \text{ (300:5)} \end{aligned}$$

$$CTF = \frac{1024 \times 230}{10 \times 300} = 78 \text{ (Round to whole number)}$$

IMPORTANT

This setpoint **MUST** be programmed when the unit is installed.

RECY. DELAY – The Recycle Delay displays the current recycle delay setpoint in minutes.

TO CHANGE THE ADJUSTABLE SETPOINTS

Adjustable Setpoints are stored in RAM (random access memory) and are easily changed in the field.

CAUTION: Adjustable Setpoints are lost if power is interrupted and the battery is not fully charged. To facilitate re-entry, we suggest that a list of Adjustable Setpoints be affixed to one end of the MicroComputer Control Center for reference.

NOTE: The following procedure also applies to the changing of the Security, Setback and Auto Cycle display setpoints.

1. Press the **CHANGE** key to rotate the display to the Adjustable Setpoints display.
2. Press the **STEP** key to move or step a set of flashing brackets through the various setpoints. A setpoint is selected for change or update when it is enclosed by the flashing brackets.

NOTE: The **DAY** indicator, itself, will flash when selected for change or update.

3. Having selected the setpoint to be changed, the **NUMERIC KEYPAD** may be used to enter the new setpoint.

NOTE: All digits must be entered, including zeros. For example. (01.0).

NOTE: The **DAY**, **BAUD RATE**, **DEAD BAND**, AND **PROPORTIONAL BANDS** setpoints, once selected, are changed or updated by pressing the **CHANGE** key.

4. In the event that an incorrect setpoint is keyed in all or part, press the **CLEAR** key to restore the original setpoint. Pressing the **CLEAR** key a second time will eliminate the flashing brackets.
5. Having keyed the desired setpoint, press the **ENTER** key. The new setpoint will be entered and the flashing brackets will move or step to the next setpoint.

NOTE: A setpoint entry outside the parameters of the Adjustable Setpoint display will be refused and the original Adjustable setpoint will be restored.

HOW TO DETERMINE ADJUSTABLE SETPOINTS

Adjustable Setpoints should reflect values compatible with normal system operation. A too high Low Suction Pressure Alarm setpoint may cause nuisance prealarms. Similarly, cutout setpoints should not fall within what are considered normal plant operation.

RANGES AND DEFAULTS ARE SHOWN BELOW

	RANGES	DEFAULTS
HI DISCH. CUT	270 g Max	270g
HI DISCH. ALARM	270g Max	260g
LO SUCT. CUT	52.7 Fixed	52.7g Fixed
LO. SUCT. ALARM	50.0 Min	55g
MLC 1 STOP LOAD	0-110%	100%
MLC 2 FORCE UNLOAD	0-115%	104%
CAP. CONTROL	38°-70°F	45°
LIQ. TEMP. CUT-OUT	36°-66°F	41°
LIQ. TEMP. ALARM	38°-70°F	42°

The Capacity control setpoint should be the equivalent of the normal suction condition.

FIXED SETPOINTS DISPLAY*
(Refer to DISPLAY SCREENS Page 35)

FIXED SETPOINTS

The Fixed Setpoints display lists all fixed setpoints, program version, plus low oil alarm and low oil cutout setpoints.

Fixed setpoints define the limits of acceptable compressor operation. Fixed Setpoints are factory determined, stored in programmed memory (PROM), and will remain in memory if power to the MicroComputer is interrupted.

HI DISCH CUT – The High Discharge Temperature Cutout, reported in degrees Fahrenheit, will shut down the compressor if the discharge temperature equals, or exceeds, this setpoint.

HI DISCH ALARM – The High discharge Temperature Alarm, reported in degrees Fahrenheit, will trigger will trigger a pre-alarm if the discharge temperature equals, or exceeds, this setpoint.

LOW OIL TEMP CUT – The Low Oil Temperature Cutout, reported in degrees Fahrenheit, will shut down the compressor if the oil temperature equals, or falls below, this setpoint.

LOW OIL TEMP ALARM – The Low Oil Temperature Alarm, reported in degrees Fahrenheit, will trigger a pre-alarm if the oil temperature equals, or falls below, this setpoint.

FULL LUBE – Pump type is indicated.

PGM/ – Microprocessor Program version.

FILTER – The Oil Filter setpoint will trigger an alarm when the differential pressure across the oil filter equals, or exceeds, 25 pounds per square inch (PSI) for 15 seconds, or longer.

* Displays for illustrative purposes only.

OIL HEATER – The Oil Heater setpoint, reported in degrees Fahrenheit, turns on the oil separator heater(s) when the oil temperature equals, or falls below, this setpoint whenever the compressor is NOT running.

LOW OIL CUT – The Low Oil Cutout will shut down the compressor when the oil pressure equals, or falls below, this setpoint.

LOW OIL ALARM – The Low Oil alarm will trigger a pre-alarm when the oil pressure equals, or falls below, this setpoint.

ANNUNCIATOR DISPLAY*
(Refer to DISPLAY SCREENS page 35)

ANNUNCIATOR: PG-1 THRU 10-01-89 15:33:36
(Use STEP key to advance PAGE)

High Press. Cutout *****

High Pressure Alarm *****

High Press. Cutout *****

High Pressure Alarm *****

High Press. Cutout *****

High Pressure Alarm *****

ANNUNCIATOR: PG-2 THRU 10-01-89 15:33:36
(Use STEP key to advance PAGE)

Lo Temp. Cutout *****

Lo Temp Alarm *****

High Press. Cutout *****

High Pressure Alarm *****

ANNUNCIATOR: PG-3 THRU 10-01-89 15:33:36
(Use STEP key to advance PAGE)

Comp. Auxiliary *****

Pump Auxiliary *****

Oil Level *****

Comp. Differential *****

Dirty Filter *****

* Displays for illustrative purposes only.

ANNUNCIATOR: PG-4 THRU 10-01-89 15:33:36 (Use STEP key to advance PAGE)	
Lo Flow (Shutdown)	*****
Lo Liq. Temp. Alarm	*****
Lo Liq. Temp. Counter	*****

* Displays for illustrative purposes only.

When a pre-alarm or cutout occurs, a flashing ALARM or CUTOOUT indicator will appear in the lower right hand corner of the Operating display. To determine the fault, rotate to the Annunciator display by pressing the CHANGE key.

The Annunciator display lists all key operative points on four sequential displays. These displays can be rotated from page #1 thru page #4 by pressing the STEP key. When a pre-alarm or cutout is triggered, the pertinent point will flash, and the time of the occurrence will be recorded to the right of the alarm. Pre-alarms are self-clearing. At this time the alarm will stop flashing, but the time of the first occurrence will still be recorded to the right of the alarm. Pressing the CLEAR key while at the Annunciator display will clear all alarms and/or cutouts.

In order to restore the Annunciator display and resume normal operation it will be necessary to go through the following steps:

1. Correct the conditions causing the alarm.
2. Press the ALARM SILENCE key. (This action may precede correcting the conditions causing the alarm).
3. To clear or reset the Annunciator pages, press the CLEAR key. This will also clear the ALARM or CUTOOUT indicator from the Operating display.
4. Press [F1] key to call-up the Operating display. If the conditions causing the alarm have not been corrected or a new fault has occurred, a new ALARM or CUTOOUT message will appear.

NOTE: Use of the Emergency Stop Button may trip one or more alarm setpoints.

SHUTDOWN RECORD DISPLAY*
(Refer to DISPLAY SCREENS page 36)

SHUTDOWN RECORD: THRU 10-01-89 15:33:36 (Use STEP key to advance PAGE)	
Lo Temp. Cutout	*****
Lo Temp Alarm	*****
High Press. Cutout	*****
High Pressure Alarm	*****

* Displays for illustrative purposes only.

The Shutdown Record display keeps a record of the last six shutdowns (cutouts). This information will help troubleshoot persistent operational problems. The most recent cutout will appear on the top line of the display with the oldest appearing on the last or bottom line. When a cutout occurs, all information is moved down one line and the new cutout appears at the top. When the display is full, the oldest record is dropped off the display and is not retained in memory. The information presented is echoed from the Annunciator display; providing the type of cutout, the day, the date, and the time.

NOTE: This information will not be lost due to power failure.

FREEZE DISPLAY*
(Refer to DISPLAY SCREENS page 36)

FREEZE DISPLAY: Thru 10-05-89 15:33:36					
Suction	Disch	Oil Filter	Compressor		
20.0 g	225 g	170 g	01 PSID	OFF	Mode
+015° F	140° F	135° F			RECYCLE
V Ratio	S V Pos	Pump	%FLA	Sep 132°F	
4.6	090%	OFF	080%	HTR off	
Auto	Auto			CUTOOUT	
Liq. Temp. = +44°F			Liq. Level = 50%		

* Displays for illustrative purposes only.

The Freeze display has the same appearance and contains the same information as the Operating display. (For a description of the information presented by the Freeze

display, refer to the Operating display, page 5). The Freeze display freezes the information of the Operating display AT THE MOMENT OF A COMPRESSOR CUTOUT. The information on the Freeze display can help the operator to identify the cause of a fault which occurred when no one was present. The Freeze display will retain the information generated by a cutout until a new cutout occurs or power is removed from the Micro-Computer.

CAUTION: Do not confuse the Freeze display with the Operating display. In order to avoid confusion remember that the displayed information on the Operating display is constantly being updated and changed. The Freeze display is fixed and FREEZE DISPLAY appears in the upper left hand corner of the display.

NOTE: The Freeze display will appear as a blank screen when power is initially furnished to the unit, and it will return to a blank screen anytime power is removed from the MicroComputer.

SECURITY DISPLAY*

<p>SECURITY DISPLAY: Thru 10-01-89 15:33:36</p>
<p>Setpoints Access — — — [Enabled] Keyboard</p>
<p>Enter Access Code — — — [* * * * *]</p>
<p>Press F2 To Exit</p>

* Display for illustrative purposes only.

The [F2] function key will call up the Security display. The Security display allows the operator to either enable or disable the Control Center's keyboard and, thereby, prevent unauthorized tampering with the various adjustable setpoints. When enabled, the MicroComputer keyboard is fully operative and the security lockout is not in effect. When disabled, the keyboard is rendered partially nonfunctional. All displays will still be accessible through the keyboard. If any attempt is made to enter new adjustable setpoints, however, the MicroComputer will default to the Security display.

TO ENABLE THE KEYBOARD, press the **STEP** key so that the brackets beside Enter Access Code flash, key the proper five digit access code, and press **ENTER**. The

Setpoints Access will toggle from disabled to enabled and adjustable setpoint entry is now possible.

TO DISABLE THE KEYBOARD, press the [F2] function key to call up the Security display. Press the **STEP** key until the brackets beside Enter Access Code flash, key the proper five digit access code, and press **ENTER**. Now, press the **STEP** key until the brackets beside Setpoints Access flash and press the **CHANGE** key to toggle from enabled to disabled.

TO CHANGE THE ACCESS CODE, press the [F2] function key to call up the Security display. Press the **STEP** key until the brackets beside Enter Access Code flash, key the proper five digit access code, and press **ENTER**. Now select the Enter Access Code a second time by pressing the **STEP** key until the brackets beside Setpoints Access flash, key in the new five digit access code, and press **ENTER**.

NOTE: Power loss will not effect the Security Display.

NOTE: IF NO ACCESS CODE WAS ENTERED AND THE DISABLED COMMAND WAS SELECTED, THE ACCESS CODE IS [00000].

LOST OR FORGOTTEN ACCESS CODE: Consult YORK Service Dept. for assistance:

AUTO CYCLE DISPLAY*
(Refer to DISPLAY SCREENS page 37)

<p>AUTO CYCLE DISPLAY: Thru 10-01-89 15:33:36</p>
<p>Refer to DISPLAY SCREENS Page 37</p>
<p> </p>

* Display for illustrative purposes only.

The Auto Cycle display provides for independently adjustable setpoints to turn the compressor on and off in response to the chilled liq. temp. or as an adjustable setpoint to limit the minimum slide valve position.

NOTE: To change the Auto Cycle setpoints, refer to "TO CHANGE THE ADJUSTABLE SETPOINTS"

ADJUSTABLE SETPOINTS: ID = [] [- -]	
Cap. Control ---- []	Day [: :]
Lo Suct Cutout - []	Baud []
Lo Suct Alarm -- []	
Hi Disch Cutout []	Flow [NC]
Hi Disch Alarm []	
M.L.C. Stop Load ----- [%]	CT Factor []
M.L.C. Force Unld ----- [%]	Recy. Delay - [30]

FIG. 3 – ADJUSTABLE SETPOINTS DISPLAY

CHILLED LIQ. TEMP. – Constantly monitors and displays the Liq. Temp. in degrees F.

COMPRESSOR START – Compressor Start-up will bring the compressor back on line when the Liq. Temp. rises to the displayed setpoint.

COMPRESSOR STOP – Compressor Stop will shut down the unit if the Liq. Temp. drops to or below the displayed setpoint limit.

NOTE: This limit must be set higher than Low Liq. Cutout and the Low Liquid alarm setpoints.

MINIMUM SLIDE VALVE – Minimum Slide Valve Position, shown as a percentage, will limit the slide valve position to the displayed setpoint.

AUTO CYCLE ACTIVE – Indicates whether Auto Cycle is active (Yes) or not active (No). Press the **CHANGE** key while at this setpoint to change the status. Upon deactivation, the compressor will return to the previous mode of operation.

CYCLE FLOW INPUTS

Digital input 2 includes multi sequence and cycling devices input. If any of the "SWITCHES" are not closed, the unit cannot start. If the unit is running and any "SWITCH" opens, the unit will shutdown. These safeties are "RUN PERMISSIVE" inputs and will auto restart or restart the unit once all safeties are cleared. No message is displayed. Factory jumpers for both inputs are supplied. **INSTALL THE SUPPLIED JUMPERS WHEN THE OPTIONAL CYCLING DEVICES ARE NOT INSTALLED.**

SWITCHES/SHUTDOWNS AND INPUTS

Digital input 7 will include both Flow Switch Inputs, Discharge Valve Interlock and Safety Devices Input. If any of the four "SWITCHES" are not closed, the unit

cannot START. If the unit is running and any "SWITCH" opens, the unit will shutdown. These safeties require a manual RESET. Message displayed is "FLOW". Factory jumpers for the condenser flow input and the SAFETY DEVICES input are supplied. A five second software "FILTER" is supplied to avoid nuisance flow switch shutdowns.

NOTE: The Control Center is supplied with jumpers for the condenser flow switch and both safety device terminals. Should condenser flow and/or the safety device inputs be utilized, the appropriate jumper must be removed. Chiller flow protection is mandatory.

CYCLING

Pump operation:

If discharge pressure g – suction pressure g is ≥ 95 then pump is "OFF".

If discharge pressure g – suction pressure g is ≤ 85 then pump is "ON".

This leaves a 10 lb. transition deadband with no change.

When oil pressure in g reaches the actual displayed values for OPCO/OPA then cutout or alarm will occur.

Calculations for OIL PRESSURE CUT OUT/OIL PRESSURE ALARM:

During compressor operation:

$$\text{OPCO} = (.39 \times \text{suction in g}) + (.61 \times \text{discharge in g})$$

$$\text{OPA} = (.39 \times \text{suction in g}) + (.61 \times \text{discharge in g}) + 10$$

During Pre-lube Drive to Compressor Start:

$$\text{OPCO} = \text{Condenser Pressure} + 5 \text{ PSIG}$$

SECTION 2

HOW THE YORK MICROCOMPUTER CONTROL CENTER WORKS

SUMMARY

The YORK MicroComputer Control Center has four(4) major components and a variety of sensors. The major components are the SBC (single board computer) two (2) display screens, and the keyboard.

The SBC can be considered the brain of the Micro-Computer Control Center. The SBC contains the logic center which provides the rules by which the Microcomputer will operate, the integrated circuit chips which store the burned in memory of how the Codepak YORK Rotary Screw Chiller is to behave, an analog input to convert VDC from the various sensors into computer binary language, and a RAM (random access memory) integrated circuit chips to store information which can be readily changed by the MicroComputer or, as in the case of adjustable setpoints, by the operator. The SBC collects information, processes the information, and delivers instructions to the displays and to the output modules.

The SBC gathers information from several sources on the chiller unit. Pressure transducers sense changes in pressure and return a variable DC voltage of 0.5 to 4.5 to the SBC. The signals are converted into binary code which the MicroComputer understands. The Micro-Computer scans the incoming data many times per second and compares the information it receives with the instructions programmed in the PROM chips, information stored in the RAM chips and instructions it has received from the control center keyboard. As operating conditions change the MicroComputer also forwards the information it is receiving to the display screen. When an operating condition or conditions develop which the MicroComputer program identifies as requiring a specific action, the microprocessor then generates an instruction which is forwarded to the output modules. The instruction triggers a solid state output device capable of handling control voltage and the instruction is executed. In some cases such as load and unload instructions, the computer displays the instruction on the Operating display with an L (load) or U (unload) symbol at the same time as the appropriate output is energized.

If the MicroComputer Control Center receives information that indicates an abnormal operating condition has been reached, or is present it will generate one or more of the following instructions:

1. If a subsystem on the compressor unit, such as the oil heater(s) can correct the problem: the Micro-Computer Control Center will energize or de-energize this system.
2. If a pre-alarm setpoint has been reached the Micro-Computer will trigger the pre-alarm and display this

information on the Operating display and the Annunciator display.

3. If a cutout setpoint has been reached the Micro-Computer will trigger the pre-alarm and shut down the chiller. The MicroComputer will indicate CUTOOUT on the Operating display and the information present on the Operating display at the moment of cutout will be stored and can be retrieved by rotating displays to the Freeze display. Additional information will be available through the Annunciator and Shutdown Record displays.

A typical example of how the MicroComputer responds can be illustrated by the responses generated by the microprocessors as oil temperature increases. Assume that the ambient temperature and chiller unit temperature is 45°F and you have just pressed the **RUN** key to start the Codepak Chiller unit:

AT 45 DEGREES F.

MicroComputer receives information that the oil temperature is below 49°F, the low oil temperature cutout setpoint, and triggers an alarm. The Micro-Computer will prevent the Codepak chiller from being started. The MicroComputer also instructs the oil heater output to energize the oil heater(s).

AT 50 DEGREES F.

When the oil temperature reaches 50°F the Microcomputer will allow the Low Oil Temperature Cutout to be cleared and the Codepak chiller unit can now be started. (Assume that the **RUN** key has been pressed and that the chiller has now started). The low oil temperature alarm would still be engaged and cannot be cleared until oil temperature exceeds 58°F. The oil heater(s) shut off on compressor start.

AT 122 DEGREES F.

The MicroComputer Control Center instructs the 2 oil heater(s) output to de-energize (This is failsafe. The heater(s) should already be de-energized due to compressor running.)

AT 125 TO 180 DEGREES F.

Normal operating range. The MicroComputer Control Center continues monitoring oil temperature and reporting this information on the Operating display.

NOTE: If the operator makes an error by attempting to start the compressor under conditions outside safe normal operating conditions, the Micro-Computer Control Center will prevent start-up and advise the operator of the fault.

SECTION 3 SERVICE

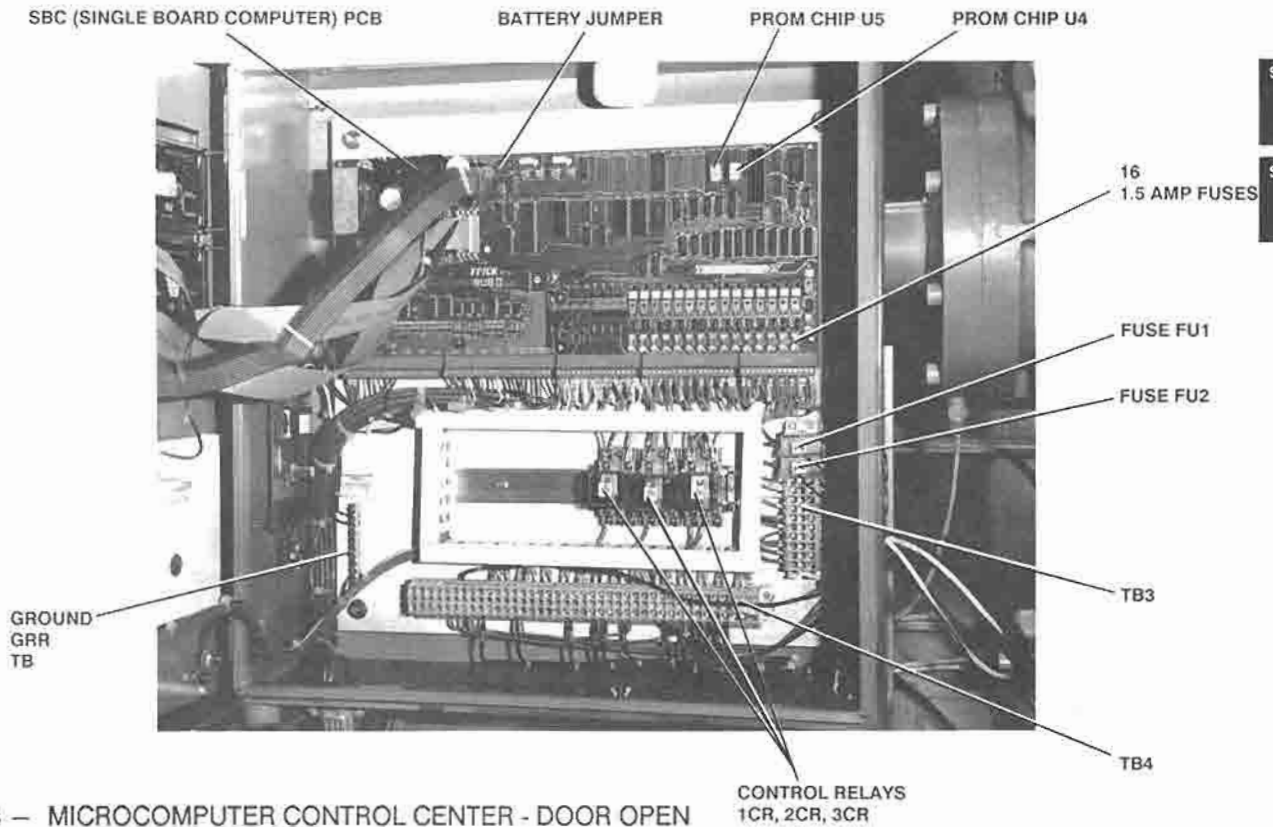

SECTION 2
SECTION 3

FIG. 4 – MICROCOMPUTER CONTROL CENTER - DOOR OPEN

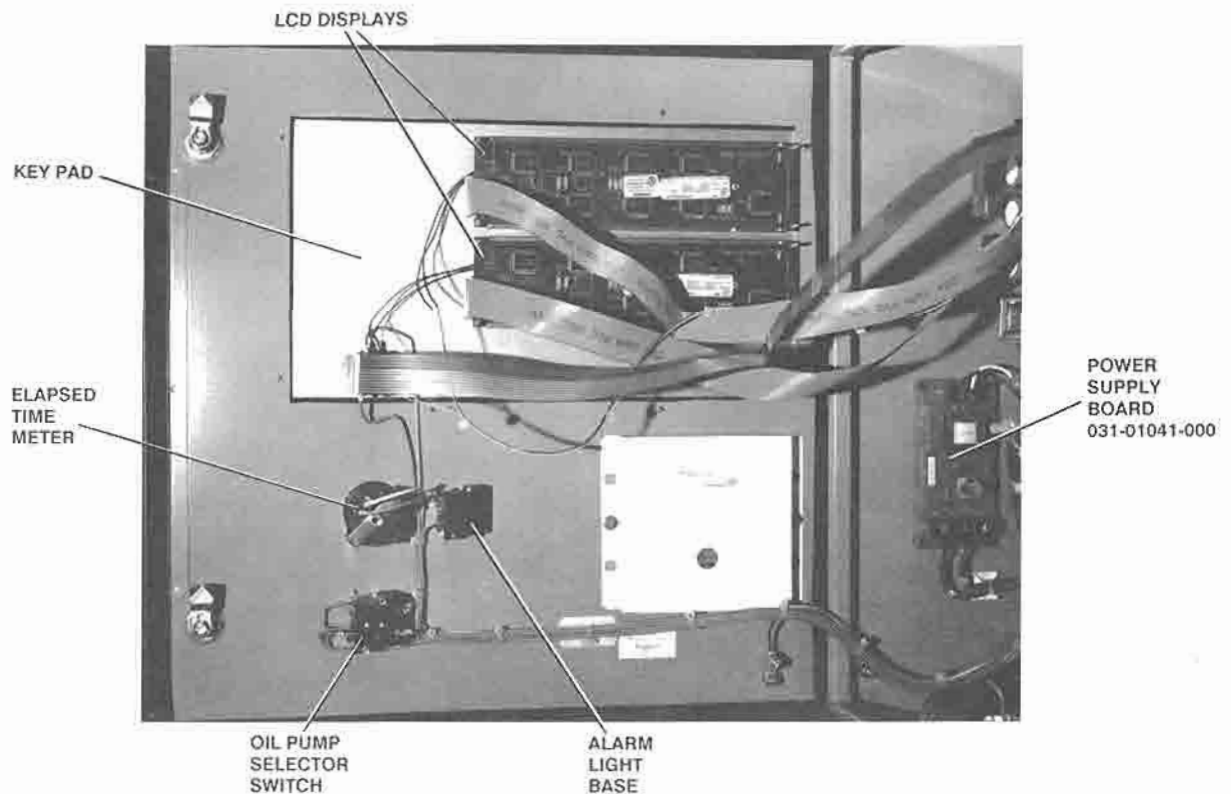

FIG. 5 – MICROCOMPUTER CONTROL CENTER - VIEW INSIDE OF DOOR

EPROM MEMORY I/C CHIP REPLACEMENT

Microprocessor EPROM memory I/C chips are located inside the MicroComputer Control Center console on the SBC (Single Board Computer) board. A special tool is required to remove these chips to prevent damaging them. The procedure to replace EPROM memory chips is outlined below:

1. Shut off control power.
2. Remove the MicroComputer Control Center cover.
3. Using a chip extraction tool, remove old and install new chip.

NOTE: The chip labelled PROM 1 must be inserted into socket U4 and the chip labelled PROM 2 must be inserted into socket U5. (See SECTION-5, page 26, Troubleshooting the MicroComputer Control Center).

CAUTION: THE NOTCHED END OF THE CHIP MUST BE UP WHEN THE CHIP IS INSERTED.

NOTE: Eproms are susceptible to damage caused by static electricity. Refer to FORM 55.05-NM11 on static damage.

OUTPUT FUSE REPLACEMENT (1FU and 2 FU)

1. Shut off control power.
2. Remove the MicroComputer Control Center cover.
3. Identify faulty fuse.
4. Use voltmeter to verify that no voltage is present on either side of the fuse.
5. Remove faulty fuse using fuse puller.
6. Install new plug-type fuse.

SECTION 3

PRESSURE TRANSDUCERS

Testing

There are four (4) transducers used on the unit. They are as follows:

1. Condenser	300 PSIG Transducers	15 VDC Input .5 to 4.5 VDC Output
2. Oil Filter		
3. Oil		
4. Suction (Cooler)	125 PSIG Transducers	

YORK PART NO.	KAVLICO PART NO.	FULL SCALE PRESS.	MAX. STANDBY PRESS.	MAX. OPER. PRESS.	PRESS. AT 0.5 VDC	PRESS. AT 4.5 VDC
025-28955-001	P455-5022	300 PSI	300 PSI	300 PSI	0.0 PSIG	300 PSI
025-28955-002	P455-5023	139.7	314.7 PSIA	139.7 PSIA	64.7 PSIA	139.7 PSIA

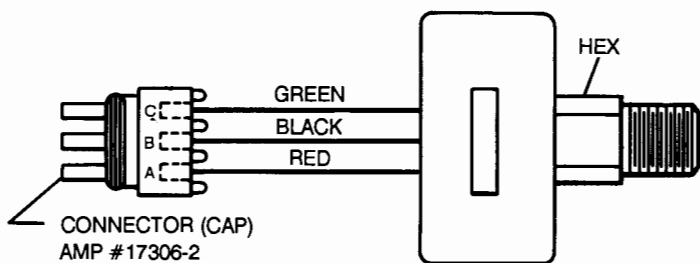

OIL PRESS., FILTER PRESS. AND DISCHARGE TRANSDUCER 025-28955-001

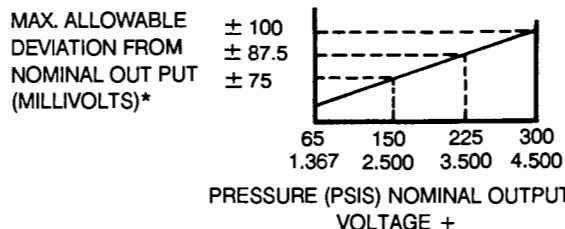

ELECTRICAL CONNECTION
 RED - POSITIVE SUPPLY (+15 VDC)
 GREEN - OUTPUT (SIGNAL)
 BLACK - COMMON (NOT CONNECTED TO CASE)

SUCTION PRESS. TRANSDUCER 025-28955-002

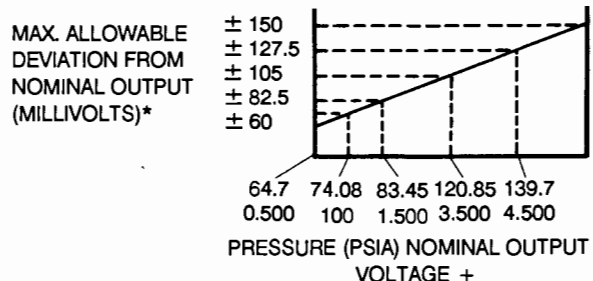

* Includes Accuracy, Linearity, Hysteresis, Repeatability, Temp. Drift Effects.
 + With 15.000 VDC Supply

FIG. 7 – PRESSURE TRANSDUCERS

TABLE 1
CONDENSER, OIL AND OIL FILTER PRESSURE TRANSDUCERS
PRESSURE VS. VOLTAGE

(PART NO. 025-28955-001)

Pressure = 75V - 37.5 OR Volts = 0.0133P + 0.5

PRESSURE (PSIG)	VOLTAGE (DC)	PRESSURE (PSIG)	VOLTAGE (DC)	PRESSURE (PSIG)	VOLTAGE (DC)
65	1.367	116	2.047	167	2.727
66	1.380	117	2.060	168	2.740
67	1.394	118	2.074	169	2.754
68	1.407	119	2.087	170	2.767
69	1.420	120	2.100	171	2.780
70	1.434	121	2.114	172	2.794
71	1.447	122	2.127	173	2.807
72	1.460	123	2.140	174	2.820
73	1.474	124	2.154	175	2.834
74	1.487	125	2.167	176	2.847
75	1.500	126	2.180	177	2.860
76	1.514	127	2.194	178	2.874
77	1.527	128	2.207	179	2.887
78	1.540	129	2.220	180	2.900
79	1.554	130	2.234	181	2.914
80	1.567	131	2.247	182	2.927
81	1.580	132	2.260	183	2.940
82	1.594	133	2.274	184	2.953
83	1.607	134	2.287	185	2.967
84	1.620	135	2.300	186	2.980
85	1.634	136	2.314	187	2.993
86	1.647	137	2.327	188	3.007
87	1.660	138	2.340	189	3.020
88	1.674	139	2.354	190	3.033
89	1.687	140	2.367	191	3.047
90	1.700	141	2.380	192	3.060
91	1.714	142	2.394	193	3.073
92	1.727	143	2.407	194	3.087
93	1.740	144	2.420	195	3.100
94	1.754	145	2.434	196	3.113
95	1.767	146	2.447	197	3.127
96	1.780	147	2.460	198	3.140
97	1.794	148	2.474	199	3.153
98	1.807	149	2.487	200	3.167
99	1.820	150	2.500	201	3.180
100	1.834	151	2.514	202	3.193
101	1.847	152	2.527	203	3.207
102	1.860	153	2.540	204	3.220
103	1.874	154	2.554	205	3.233
104	1.887	155	2.567	206	3.247
105	1.900	156	2.580	207	3.260
106	1.914	157	2.594	208	3.273
107	1.927	158	2.607	209	3.287
108	1.940	159	2.620	210	3.300
109	1.954	160	2.634	211	3.313
110	1.967	161	2.647	212	3.327
111	1.980	162	2.660	213	3.340
112	1.994	163	2.674	214	3.353
113	2.007	164	2.687	215	3.367
114	2.020	165	2.700	216	3.380
115	2.034	166	2.714	217	3.393

TABLE 2
COOLER SUCTION
PRESSURE VS. VOLTAGE

(PART NO. 025-28955-002)

Pressure = 18.75 + 40.625 OR Volts = 0.0533P - 2.167

PRESSURE (PSIG)	VOLTAGE (DC)	PRESSURE (PSIG)	VOLTAGE (DC)	PRESSURE (PSIG)	VOLTAGE (DC)
50.0	0.500	75.5	1.860	101.0	3.220
50.5	0.527	76.0	1.887	101.5	3.247
51.0	0.553	76.5	1.913	102.0	3.273
51.5	0.580	77.0	1.940	102.5	3.300
52.0	0.607	77.5	1.967	103.0	3.327
52.5	0.633	78.0	1.993	103.5	3.353
53.0	0.660	78.5	2.020	104.0	3.380
53.5	0.687	79.0	2.047	104.5	3.407
54.0	0.713	79.5	2.073	105.0	3.433
54.5	0.740	80.0	2.100	105.5	3.460
55.0	0.767	80.5	2.127	106.0	3.487
55.5	0.793	81.0	2.153	106.5	3.513
56.0	0.820	81.5	2.180	107.0	3.540
56.5	0.847	82.0	2.207	107.5	3.567
57.0	0.873	82.5	2.233	108.0	3.593
57.5	0.900	83.0	2.260	108.5	3.620
58.0	0.927	83.5	2.287	109.0	3.647
58.5	0.953	84.0	2.313	109.5	3.673
59.0	0.980	84.5	2.340	110.0	3.700
59.5	1.007	85.0	2.367	110.5	3.727
60.0	1.033	85.5	2.393	111.0	3.753
60.5	1.060	86.0	2.420	111.5	3.780
61.0	1.087	86.5	2.447	112.0	3.807
61.5	1.113	87.0	2.473	112.5	3.833
62.0	1.140	87.5	2.500	113.0	3.860
62.5	1.167	88.0	2.527	113.5	3.887
63.0	1.193	88.5	2.553	114.0	3.913
63.5	1.220	89.0	2.580	114.5	3.940
64.0	1.247	89.5	2.607	115.0	3.967
64.5	1.273	90.0	2.633	115.5	3.993
65.0	1.300	90.5	2.660	116.0	4.020
65.5	1.327	91.0	2.687	116.5	4.047
66.0	1.353	91.5	2.713	117.0	4.073
66.5	1.380	92.0	2.740	117.5	4.100
67.0	1.407	92.5	2.767	118.0	4.127
67.5	1.433	93.0	2.793	118.5	4.153
68.0	1.460	93.5	2.820	119.0	4.180
68.5	1.487	94.0	2.847	119.5	4.207
69.0	1.513	94.5	2.873	120.0	4.233
69.5	1.540	95.0	2.900	120.5	4.260
70.0	1.567	95.5	2.927	121.0	4.287
70.5	1.593	96.0	2.953	121.5	4.313
71.0	1.620	96.5	2.980	122.0	4.340
71.5	1.647	97.0	3.007	122.5	4.367
72.0	1.673	97.5	3.033	123.0	4.393
72.5	1.700	98.0	3.060	123.5	4.420
73.0	1.727	98.5	3.087	124.0	4.447
73.5	1.753	99.0	3.113	124.5	4.473
74.0	1.780	99.5	3.140	125.0	4.500
74.5	1.807	100.0	3.167		
75.0	1.833	100.5	3.193		

SECTION
3

Removal/Replacement Of Transducers

TOOLS REQUIRED:

1. Use an Open ended wrench.

DO NOT Under Any Circumstances, Install Or Remove any Transducers with a "Strap Wrench".

Torque applied by a strap wrench on the transducer case will cause the case to turn before the body (See Fig. 8). This turning will mis-align the internal locking tabs on the case and body causing pressure to leak around one of the internal "O" rings. When this happens, system pressure is applied to the top plate causing it to separate (blow away) from the case. In addition, the epoxy on the top plate will shatter spraying it in all directions.

When installing a transducer, as soon as the threads catch, turn it in the rest of the way with an open end wrench (See Fig. 8) applied to the hex area on the body.

When removing a transducer, turn it out entirely with an open end wrench (See Fig. 8) applied to the hex area on the body.

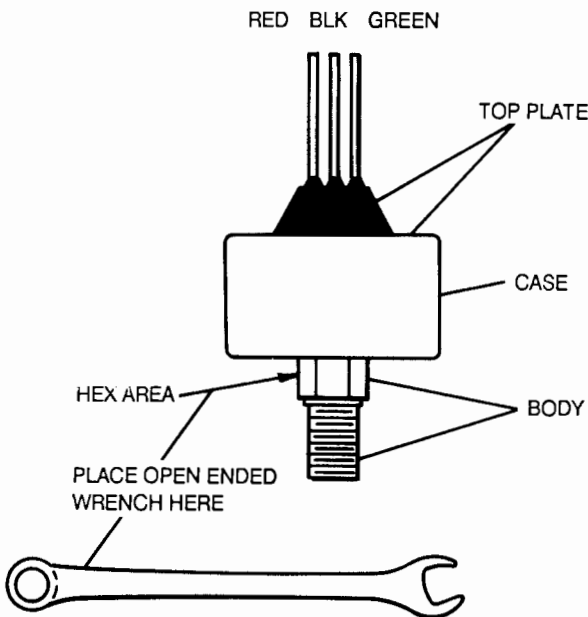

FIG. 8 – REMOVING AND REPLACING TRANSDUCER

All system pressure transducers must be installed per the following procedure. Using Teflon tape or other compounds and excessive force distorts the transducer case, causing internal leaks. Case distortion also makes transducer removal difficult if not impossible.

CHILLER TRANSDUCER INSTALLATION

Improper installation will cause slight deformities in the transducer case that allow refrigerant to leak past internal "O" rings. These leaks will cause failures to occur within hours or may take several weeks.

To install use the procedure below should be used on all transducers, whether mounted directly to chiller or on a fitting:

1. Apply primer (Part No. 013-01753-000) to the threads of transducer, allow 3 minutes for primer to dry. Primer may be purchased locally as LOCQUIC Primer N (764 Series).
2. Apply sealant (Part No. 013-02280-000) to the threads of transducer. Sealant may be purchased locally as LOCTITE PSI Pipe Sealant (567 Series).

Install transducer into port until hand tight (snug). Using proper open-end wrench, tighten transducer additional 1/2 turn.

3. Excess sealant outside the joint should be wiped away since it will not cure. Transducer can be leak checked with unit after following the above procedure.

* DO NOT substitute primer or sealant of another type or vendor. Primer and sealant must be specifically designed to be used with stainless steel.

TEMPERATURE SENSORS (Refer to Fig's. 9 and 10)

There are five (5) sensors used in the chiller. They are as follows:

SUCTION

Sensor Range is: -61° F to +118° F

DISCHARGE

Sensor Range is: +34° F to +215° F

OIL TEMP.

Sensor Range is: 0° F to +179° F

SEP. TEMP.

Sensor Range is: 0° F to +179° F

LEAVING CHILLED WATER TEMP.

Sensor Range is: -66° F to +113° F

NOTE: Although the displayed temperature ranges differ, all temperature sensors are identical.

IMPORTANT

The sensors are all Temp. to Current Converters (no resistance) and are all the same. A resistance check cannot be performed.

To check a sensor, simply un-plug the sensor in question and swap it with another sensor on the chiller. If the problem persists check the wiring and the SBC (Single Board Computer) PCB. Replace sensor if the swapped one works.



FIG. 9 – TEMPERATURE SENSOR – YORK PART NO. 025-28956-000

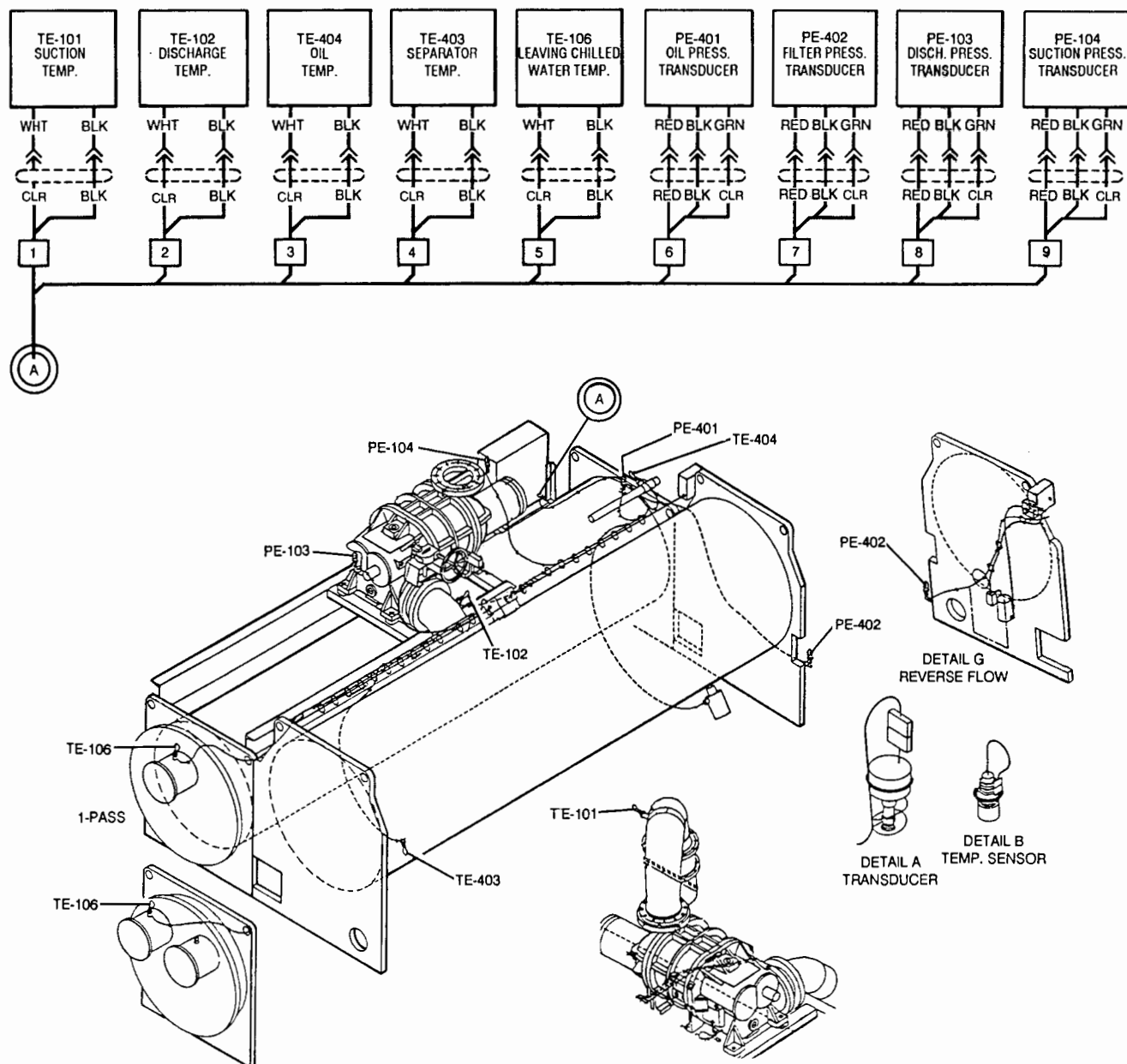

FIG. 10 – TRANSDUCERS AND SENSORS LOCATION

REFRIGERANT LIQUID LEVEL ACTUATOR/VALVE & LEVEL TRANSMITTER OPERATION

(Refer to Fig. 11)

The liquid level valve/actuator controls the refrigerant level within the subcooler. Control is accomplished by supplying 120 VAC to terminal 12 (close valve) or terminal 7 (open valve) with respect to terminal 2. Switch 2SS must be in the auto position for the valve to operate properly.

The refrigerant level is sensed by a capacitance level transmitter (LT-106) which outputs a +1 volt to +5 volt D.C. signal, corresponding to 0% and 100% level (terminals Sig 1 to GND. on 031-01041 P.C.B.). The liquid level setpoint, deadband and proportional band values are user defined and retain the default values of 50%, 1%, and 100% respectively, until changed by the user.

CALIBRATION CHECK OF LIQUID LEVEL SENSOR (LT-106) (Refer to Fig. 11)

SYMPTOM

1. If the sensor is out of adjustment the chiller will go down on LOW EVAP PRESS.
2. Oil to REFRIG. LEVEL is different on each job.
3. Needs to be checked or adjusted.
4. 50% DEFAULT VALVE.

SOLUTION

STEP 1

1. Check voltage on each panel between GND and SIG 1 terminals on circuit board Part No. 031-01041, mounted on the left hand wall of the MicroComputer enclosure. (See Fig. 5, page 15). This should indicate .85 to .95 VDC (with no refrigerant in chiller)
2. If not calibrated/adjusted correctly adjust the zero pot in the LT-106 sensor so it reads between .85 and .95 VDC.

STEP 2

1. Program in the panel a level value of 002. (Position- [.002%])
2. Start chiller.
3. Switch 2SS should be in the AUTO POSITION.
4. Slowly increase from 002 (in 10% steps), each time look at the Liquid Level readout to verify that the actual indicated value increases to the programmed value.
5. The actual value should be able to follow the programmed value up to 100%.
6. If the actual value stops somewhere between; program a value 2% less than the highest actual read-

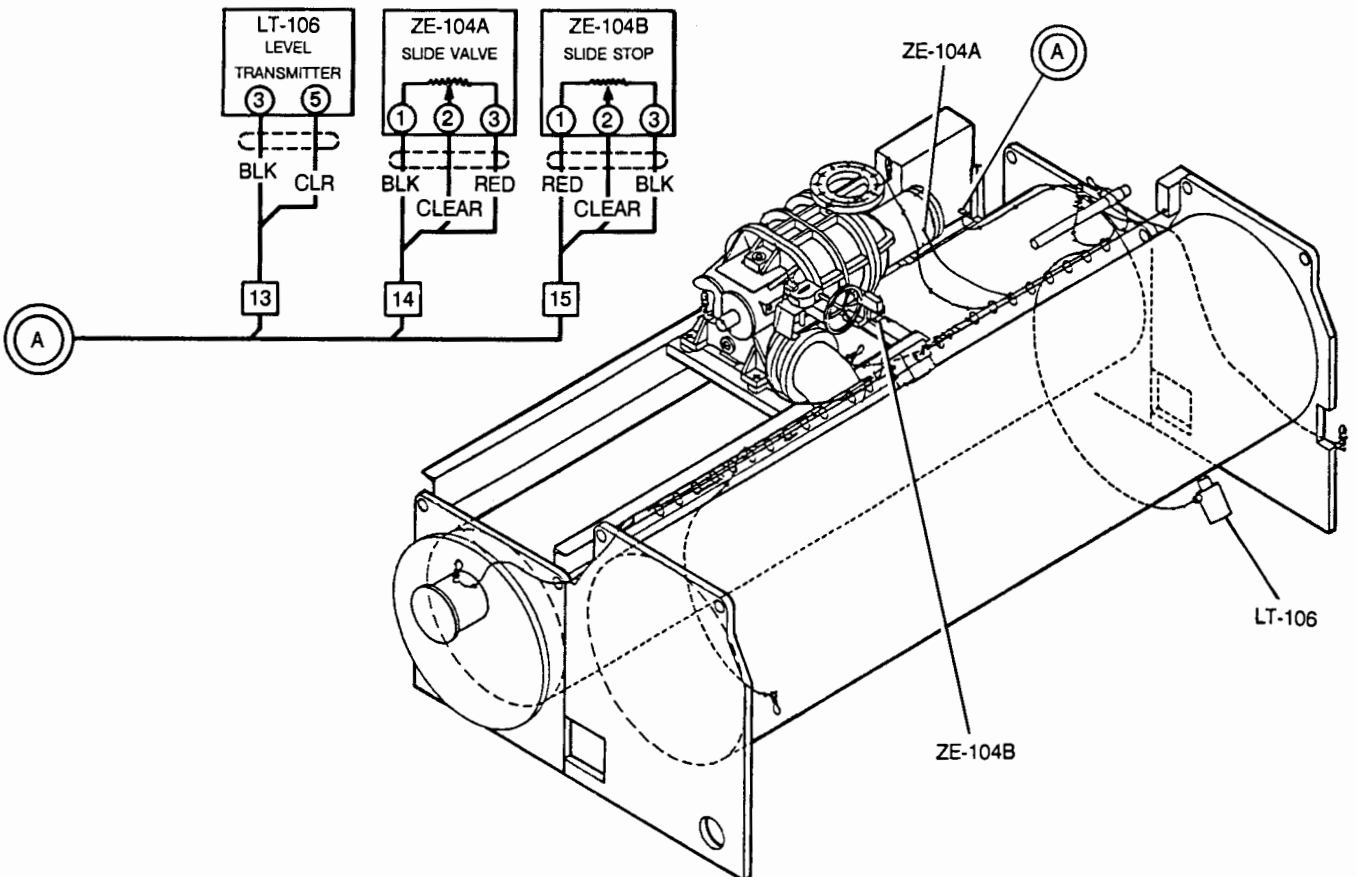

FIG. 11 – LOCATION OF REFRIGERANT LIQUID LEVEL TRANSMITTER, SLIDE VALVE CONTROL AND SLIDE STOP CONTROL

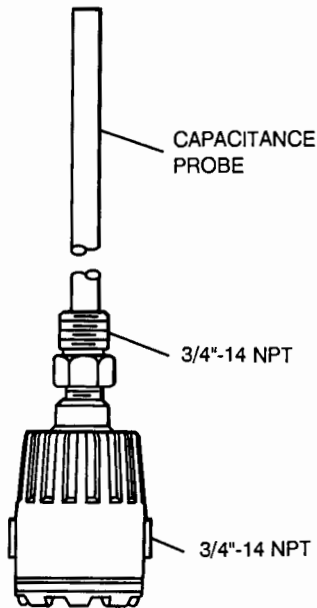

FIG. 12 – LT-106 LIQUID LEVEL SENSOR

ing. (If it stops somewhere between, this means that the probe is fully covered with refrigerant).

7. Allow the system to stabilize.
8. Liq. Level Actuator Valve wiring *must* be disconnected. (with chiller running) Refer to Form 160.65-PA2.1. (Terminal block TB4) (Terminal TB3)
 - a. Remove wires from terminal 12* and 7.* (Fig. 23, page 42).
 - b. Remove wire #12* first then #7.*
9. Adjust the SPAN pot located in the LT-106 to obtain 5 volts between GND and SIG 1 terminals on 031-01401 board (5V = 100%).
10. Connect wires #12* and #7* back on terminals.
11. Return to 050% (050% = The probe is 1/2 covered with refrigerant).

*Wires are hot (120 VAC) (Refer to Form 160.65-PA2.1)

12. Set up is complete.

NOTE: The "SPAN" and "ZERO" pots are in the sensor LT106.

Service Replacement Procedure Only

Equipment Required For The Following Calibration Check

- A. Beckman Tech #330 or equivalent digital volt meter (D.V.M.)
- B. Nail Polish (For sealing pots).

STEP 1

1. Place the LT-106 on the floor with the probe pointing upward. (Refer to Fig. 12).
2. Hook up the 2 wires from the existing wiring harness to the probe. (Refer to Fig. 13). Check the voltage between the GND and SIG 1 terminals on the 031-01041 board. It should indicate between .85 and .95 VDC. If not, go to Step 3.
3. Close zero switch #1 (coarse adj.) located in the transmitter housing and adjust the zero fine adjust pot to obtain a reading of 0.88 to 0.92 volts on the D.V.M. If the D.V.M. reads a value greater than 0.92V and 0.92V cannot be obtained, open zero switch #1 and close zero switch #2. Adjust the zero fine adjust pot to obtain a reading of 0.88 to 0.92V on the D.V.M.

STEP 2

1. Place the probe (LT-106) back into the chiller.
2. Program in a value of 002%.
3. Power up, Switch 2SS in the AUTO position. START THE CHILLER.
4. Program a value of 012%. Check to see if the level comes up.

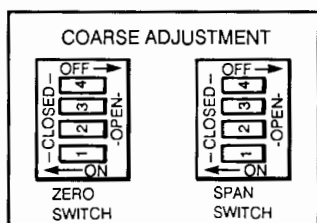
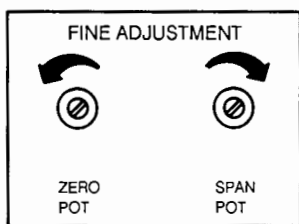
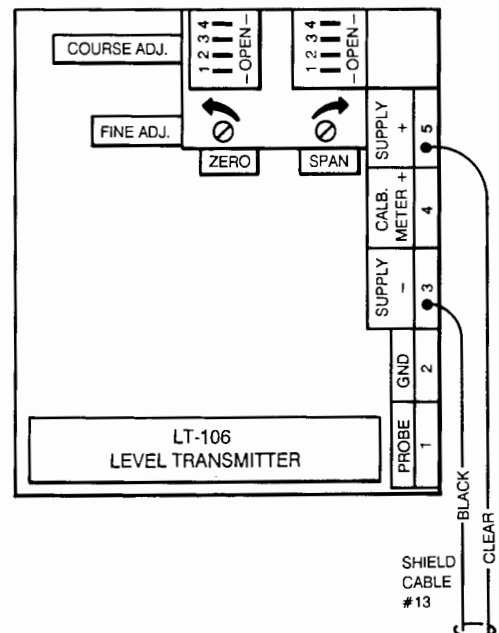

FIG. 13 – LT-106 LEVEL TRANSMITTER



5. Program in 022%. Check if the level comes up. Observe the liquid level readout to verify that value.
6. Increase in 10% steps until 100% is reached.
7. If the level readout fails to increase to the programmed value somewhere in between: Program a value 2% less than the maximum reading. (If this condition happens the probe is fully covered with refrigerant at this time.)
8. Leave the system stabilize out.
9. Liquid level actuator valve must be disconnected (with chiller running). Refer to Wiring Diagram Form 160.65-PA2.1.
 - A. Remove wires off terminal #12* (Terminal block TB4) and terminal #7* (Terminal block TB3).
 - B. Remove wire off #12 first then wire #7*
10. Adjust the Span fine adjust pot to obtain a reading of 4.90 to 5.00V on the D.V.M. If the D.V.M. reads a value less than 4.90V and 4.90V cannot be obtained, open Span Switch #3 and close Span Switch #4. Adjust the Span fine adj. pot to obtain a reading of 4.90 to 5.00V on the D.V.M.
11. Reconnect wires #12* and #7* back on the terminals.
12. Set up is complete.
13. Return to 050% (050% = The probe is 1/2 covered with refrigerant).

* Wires are hot 120VAC. (Refer to Form 160.65-PA2.1)

SV POS POTENTIOMETER REPLACEMENT AND ADJUSTMENT (Refer to Fig. 14)

The SLIDE VALVE POSITION POTENTIOMETER is located on the end of the compressor unloader cylinder.

1. Shut off control power.
2. Remove the four socket head capscrews securing the potentiometer cover to the unloader cylinder.
3. Unsolder leads to the potentiometer and remove. Loosen the setscrew on the potentiometer side of the flexible coupling.
4. Remove the three retainer clips securing the potentiometer to the base plate. The potentiometer should slip out of the coupling.
5. Install the new potentiometer and reassemble.

CAUTION: Do not apply too much heat to the pot terminals as this may damage the pot internally.

Adjustment (Refer to Fig's. 14 and 18)

ROUGH ADJUSTMENT is made with the slide valve fully unloaded and the control power off. Remove connector P5. With a digital voltmeter, measure the resistance across the red and white wires, having removed them from the SBC. The resistance should be 1000 +/- 50

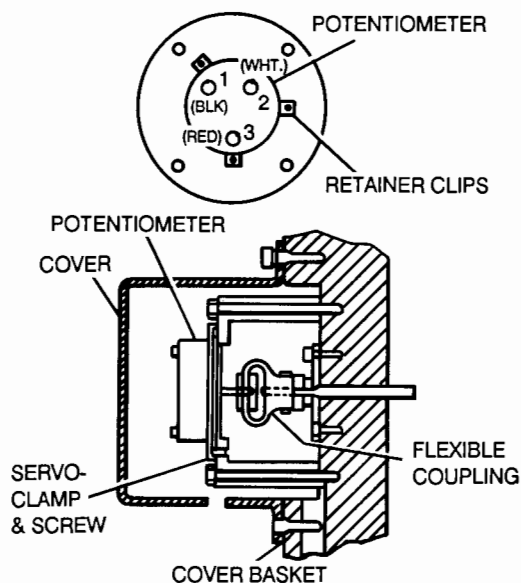

FIG. 14 – POTENTIOMETER LOCATION

ohms. If adjustment is necessary, loosen the servo clamp screws and rotate the potentiometer clockwise or counterclockwise until the resistance reading is as close to 1000 ohms as possible. Retighten the clamp screws and replace wires.

NOTE: Mechanical travel of the slide valve potentiometer is 300 degrees rotation when the slide stop is confirmed to be in the 1.7 Vi position. The travel will be less than 300 degrees if the slide stop is in any position above 1.7 Vi.

Decrease the slide stop to achieve a value of 1.7. FINE ADJUSTMENT must be made with the slide valve fully unloaded and the compressor running. The Operating display at this time should indicate a slide valve position of 0%. If the display is greater than 0%, adjust potentiometer POT #4 on the SBC until 0% is indicated. If 0% is not attainable, get as close as possible and then proceed to the next step. The adjustments of POT #4 and POT #3 are interactive and POT #3 may require adjustment to allow POT #4 to come into range.

Completely load the slide valve. The display at this time should indicate 100%. If the display is less than 100%, adjust potentiometer POT #3 on the SBC until 100% is indicated.

Repeat this sequence until the slide valve indicates 0% fully unloaded and 100% fully loaded.

VOLUMIZER POTENTIOMETER REPLACEMENT AND ADJUSTMENT (Refer to Fig's. 15 and 18)

The volumizer potentiometer is located under a cover on the right side of the compressor (facing shaft) at the inlet end.

1. Shut off control power.

2. Remove the potentiometer cover and gasket.
3. Remove the potentiometer and mounting bracket.
4. Install new potentiometer and bracket.
5. **ADJUSTMENT** must be made with the compressor running and the slide valve fully unloaded. With the slide stop at maximum Vi position, check that the potentiometer pushrod is in contact with the slide stop pushrod. If not, the bracket must be ground or trimmed until contact is made. Completely decrease the slide stop. The Operating display at this time should indicate a Vi of 1.7 if greater than 1.7 adjust potentiometer POT #2 on the SBC until 1.7 is indicated. If 1.7 is not obtainable, get as close as possible and proceed to the next step. Adjustment of POT #2 and POT #1 are interactive and POT #1 may require adjustment to allow POT #2 to come into range. Now, completely increase the slide stop. The display at this time should indicate a Vi of 2.5. If less than 2.5, adjust potentiometer POT #1 on the SBC until 2.5 is indicated. Repeat this sequence until the slide stop indicates 1.7 when fully decreased and 2.5 when fully increased.

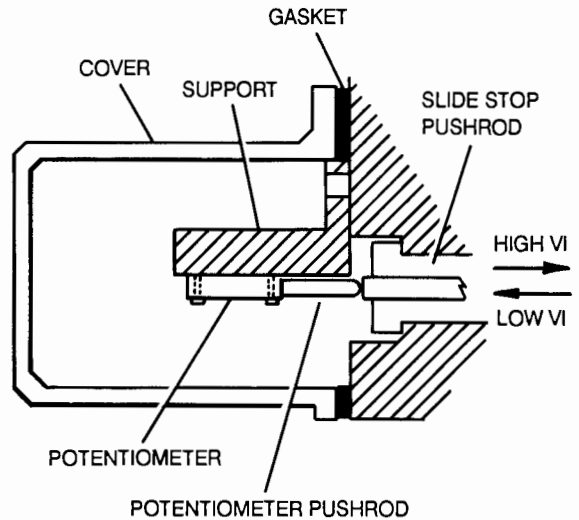

SECTION
3

FIG. 15 – VOLUMIZER POTENTIOMETER

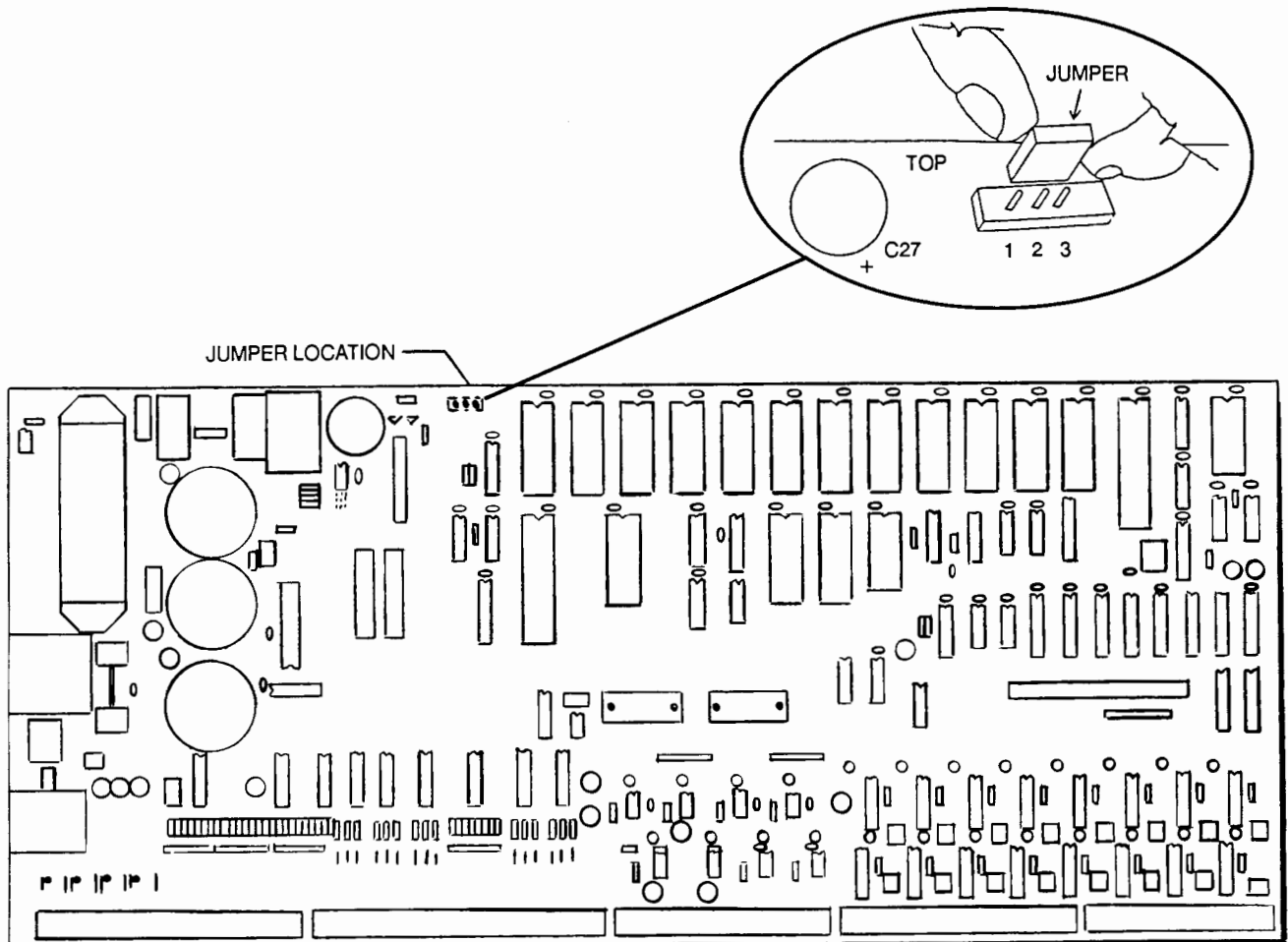
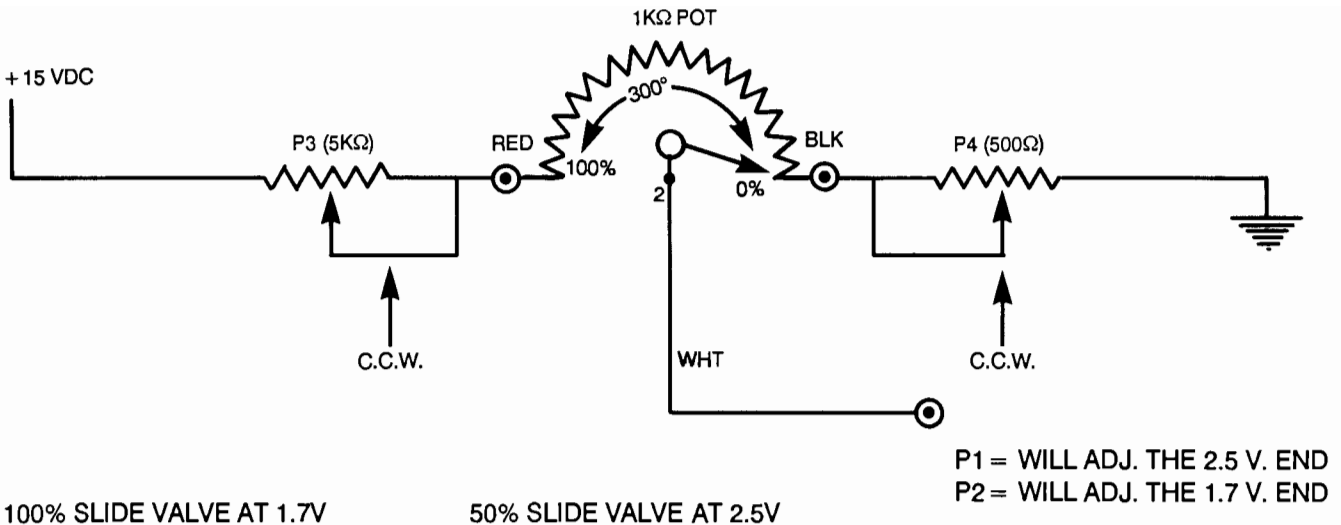
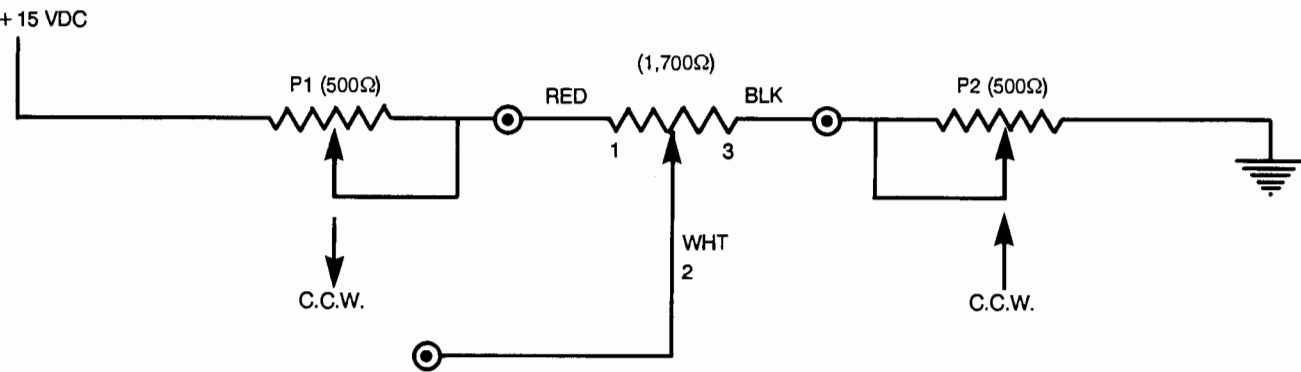

FIG. 16 – LOCATION OF BATTERY BACKUP JUMPER ON SBC SINGLE BOARD COMPUTER PCB.



NOTE: Slide Stop Must Be Adj. First Then Adj. The Slide Valve. To Start The Chiller The Slide Valve Must Be Set At 9% Or Less.

SLIDE VALVE – ADJUSTMENT



NOTE: If you can not adj., perhaps the Slide Stop Pot was not mounted correctly on the mounting bracket.

SLIDE STOP BLOW UP

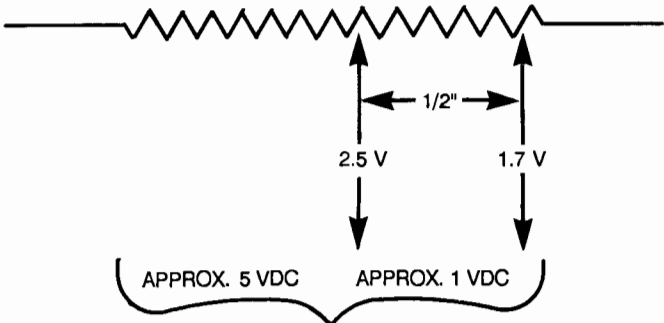

P1 = WILL ADJ. THE 2.5V END
P2 = WILL ADJ. THE 1.7V END

SLIDE STOP

FIG. 17 – SLIDE VALVE AND SLIDE STOP WIRING DIAGRAM

TEMPERATURE and/or PRESSURE ADJUSTMENT

All temperature and pressure sensors are factory set, calibration is not required. In addition to the starter package interlocks shown on the starter package diagram, the following optional interlocks are on the typical Codepak Screw Chiller unit with the Micro-Computer Control Center wiring diagram: (Form 160.65-PA2.1)

1. Remote LOAD, UNLOAD, interlocks in case the customer desires to operate the unit from a remote control device.

CHECKING MOTOR ROTATION

COMPRESSOR ROTATION IS CLOCKWISE WHEN FACING THE END OF THE COMPRESSOR SHAFT. Under NO conditions should the motor rotation be checked with the coupling center installed as damage to the compressor may result.

BATTERY BACKUP (Refer to Fig. 16, page 23)

The battery backup prevents data loss during power interruption and it will maintain the adjustable setpoints stored in RAM (random access memory) for up to 3

months after power loss. Expected battery life is ten (10) years, and a trickle charge maintains the battery backup at peak charge when control voltage is present. A battery jumper arrangement on the PCB enables and disables the battery.

To maximize battery life during extended chiller shutdown a jumper is located on the board at the top and to the right of the battery (Refer to page 18). Move the jumper from the left 2 pins (1 & 2) to the right 2 pins (2 & 3) to activate the battery function. All boards shipped with the Codepak Screw Chiller will have this jumper on the left two pins. The jumper will have to be moved to the right at the startup of the unit.

LIQUID CRYSTAL DISPLAYS ADJUSTMENT

The LCD is factory preset at 20 degrees below the horizontal for maximum contrast. To determine whether the LCD is suitably aligned, vertically move your line-of-sight up and down in front of the displays. If adjustment of the viewing angle is necessary, remove the display panel and adjust potentiometer (R7), located near the center of each of the display boards.

SECTION 3
SECTION 4

SECTION 4 COMPRESSOR MOTOR STARTER, (CT) CURRENT TRANSFORMER AND POWER FACTOR CAPACITORS

MOTOR STARTERS (Refer to Form 160.65-PA5.1)
For information about remote motor starters, current

transformers (CT'S), and power factor correction capacitors.

C.T. is a 0-5 AMP secondary C.T.
(See Form 160.65-PA5.1)

NOTE: If the SBC (Single Board Computer) is replaced the C.T. Factor must be re-set on the new P.C.B.

* C.T. is located in the Electro-Mechanical Starter

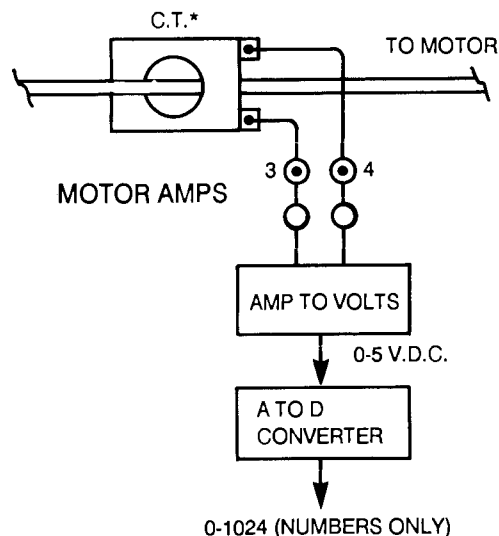

FIG. 18 – RESETTING THE C.T. FACTOR

SECTION 5

TROUBLESHOOTING, POWER DIPS, POWER FAILURES AND CHILLER START-UP FLOW CHART

TROUBLESHOOTING THE YORK CODEPAK MICROCOMPUTER CONTROL CENTER

This section contains information on troubleshooting and making corrections to the MicroComputer and control circuits of the YORK Codepak Rotary Screw Chiller unit. This section is composed of four parts: general information, a troubleshooting guide, a repair procedure guide, and an illustrative schematic and data.

GENERAL INFORMATION

WARNING: THE COMPONENTS WITHIN THE MICROCOMPUTER CONTROL CENTER CAN BE INADVERTENTLY DAMAGED BY STATIC ELECTRICITY OR MISHANDLING. ONLY QUALIFIED TECHNICIANS SHOULD DIRECTLY HANDLE THESE COMPONENTS.

1. DO NOT REMOVE the MicroComputer Control Center cover or attempt to make corrections to the microprocessor power supply without shutting off the control power. Accidental shorts can irreparably damage the SBC (single board computer) or the display screens.
2. DO NOT HANDLE the SBC or the display screen boards when their cables are disconnected without first attaching a ground strap to prevent static electrical discharge from your body.

TROUBLESHOOTING GUIDE

Successful problem solving requires an organized approach to define the problem, identify the cause, and make the proper correction. Sometimes it is possible that two relatively obvious problems combine to provide a set of symptoms that can mislead the troubleshooter. Be aware of this possibility and avoid solving the "wrong problem".

ABNORMAL OPERATION ANALYSIS and CORRECTION

Four logical steps are required to analyze an operational problem effectively and make the necessary corrections:

1. Define the problem and its limits.
2. Identify all possible causes.
3. Test each cause until the source of the problem is found.
4. Make the necessary corrections.

The first step in effective problem solving is to define the limits of the problem. If, for example, the compressor periodically experiences high oil temperatures, do not rely on this observation alone to help identify the problem. Lowering the equalizing pressure on the thermal expansion valve would increase the refrigerant feed and the oil temperature should drop.

When an operating problem develops compare all operating information on the OPERATING DISPLAY with normal operating conditions. If an Operating Log has been maintained the log can help determine what constitutes normal operation for the chiller unit in that particular system.

The following list of abnormal system conditions can cause abnormal operation of the YORK Codepak Rotary Screw Chiller:

1. Insufficient or excessive refrigeration load.
2. Excessively high suction pressure.
3. Excessively high suction superheat.
4. Excessively high discharge pressure.
5. Inadequate refrigerant charge or low oil separator level.
6. Excessively high or low temperature coolant to the oil cooler.
7. Liquid return from system (slugging).
8. Blocked tubes in water cooled oil cooler from high mineral content of water.
9. Problems in electrical service to compressor unit.
10. Air and moisture present in the system.

Make a list of all deviations from normal plant operation and normal compressor unit operation. Delete any items which do not relate to the symptom and separately list those items that might relate to the symptom. Use the list as a guide to further investigate the problem.

The second step in problem solving is to decide which items on the list are possible causes and which items are additional symptoms. High discharge temperature and high oil temperature readings on a display may both be symptoms of a problem and not casually related. High suction superheat or a low receiver level, however, could cause both symptoms.

The third step is to identify the most likely cause and take action to correct the problem. If the symptoms are not relieved move to the next item on the list and repeat the procedure until you have identified the cause of the problem. Once the cause has been identified and confirmed make the necessary corrections.

MAINTENANCE

Most problems encountered with the MicroComputer Control Center and control circuits will be the result of a wiring fault, blown fuse, or failure of a peripheral control such as a solenoid coil or a pressure transducer. Faults in the computer, while possible, are unlikely. If a fault develops in the computer, the probability is that all functions will cease and the display screens will go blank.

The control system of the YORK Rotary Screw Chiller consists of a 120 volt AC (high voltage) side and a 0-25 volt DC (low voltage) side. The 120 volt side actuates solenoids, relays, alarms, and other electro-mechanical functions. The 0-25 volt DC side operates the computer and its various sensors. the MicroComputer Control Center console contains the SBC (Single Board Computer) and two display screens.

CAUTION

High Voltages are present within the Micro-Computer Control Center, THIS CAN CAUSE INJURY OR DEATH.

To troubleshoot the low voltage side of the YORK control circuits, it is necessary to have the following tools:

1. Accurate digital multimeter*.
2. Small wire stripper.
3. Small screwdriver.
4. Small snip nose pliers.
5. 15 watt soldering iron (no larger).
6. .032,60/40 rosin core solder.
7. IC chip extraction and insertion tools*.
8. Grounding strap*.
9. Static free grounded work surface.

*Available from York. Order kit (451862)
YORK Part No. 025-28966-080

TROUBLESHOOTING THE YORK MICROCOMPUTER CONTROL SYSTEM

(Refer To Wiring Diagram Form 160.65-PA2.1 Unit Wiring and Form 160.65-3.2 Field Wiring)

MISC. SERVICE NOTES ON SBC (Single Board Computer)

The Micro will not operate without EPROM chips. When EPROMS are not installed, the micro display will only indicate a dash in the upper left hand corner of the display.

TROUBLESHOOTING

THE YORK MICROCOMPUTER CONTROL SYSTEM

(REFER TO WIRING DIAGRAMS FORM 160.65-PA2.1 AND 160.65-PA3.2)

SYMPTOM	PROBABLE CAUSES AND CORRECTIONS
DISPLAYS ARE INOPERATIVE	<p>Check the 10 amp fuse (2 FU) which controls all voltage going to the microprocessor.</p> <p>Shut off power to the MicroComputer Control Center. Remove the console cover and confirm that all cable and wire connections are made.</p>
OIL PUMP DOES NOT START	<p>Verify that the Oil Pump HAND-OFF-AUTO switch (1SS) is in the AUTO position and that the Emergency Stop Button is not depressed.</p> <p>Output 11 controls the Oil Pump Starter Relay (3CR) when in the Auto mode. If HAND is selected on 1SS, Output 11 will not have any effect on the operation of the oil pump starter.</p> <p>If AUTO has been selected and the oil pump does not start, check for 120 VAC between Wires 39 and 2. If 120 VAC is not found when the LED for Output 11 is on, check the fuse (11FU) and/or replace the output 11 module. If the problem persists, check the control relay (3CR).</p> <p>The Oil Pump Starter Auxiliary Contact switches voltage to Input 6 (Wires 19 and 5) when the auxiliary contacts are closed and the AUTO mode is selected on 1SS. If the Input does not turn on and voltage is present at input 6, consult YORK International.</p>
OIL PUMP IS RUNNING BUT THE COMPRESSOR DOES NOT START	<p>The (HAND-OFF-AUTO) Oil pump Selector Switch (1SS) controls oil pump operation and must be in the AUTO position before the compressor can be started.</p> <p>Verify that the Slide Valve has unloaded to 9% or less. If the Slide Valve has not unloaded, troubleshoot the hydraulic system. Compressor will not start until the Slide Valve is unloaded.</p> <p>Output 1 controls the motor starter. Check between terminals 38 and 2 for 120 VAC. If 120 VAC is not found when the LED for Output 1 is on, check the fuse (1FU) and/or replace the Output 1 module.</p>
COMPRESSOR AUXILIARY SHUTDOWN	<p>Output 1 controls the Compressor Start Relay (2CR). If the compressor does not start and the LED for Output 1 is on, check the fuse (1FU) and/or replace the Output 1 module. If the problem persists, check the interposing relay (2CR).</p> <p>The Compressor Starter Auxiliary Contacts turn on Input 5 when they are closed. These contacts are located within the Compressor Starter.</p>
OIL HEATERS DO NOT OPERATE	<p>The oil heaters should operate only when the compressor is NOT running and the oil in the separator sump is cold.</p> <p>If the oil heaters do not work check fuse 1FU (20 amp). If the fuse is not blown, check wires 25 and 2 and between wires 26 or 27 and 2 for 120 VAC. If 120 VAC is not found, check between wires 25 and 26 or 27. If 120 VAC is found between wires 25 and 26 or 27, the Oil Heater Relay is defective. Next, check the voltage between wires 9 and 2. If 120 VAC is present, the Oil Heater Relay is defective.</p> <p>If you do not read 120 VAC between wires 9 and 2 when the LED for Output 10 is on, check the fuse (10FU) and/or replace the output (10) module.</p>

SYMPTOM	PROBABLE CAUSES AND CORRECTIONS
SLIDE VALVE DOES NOT LOAD AND/OR UNLOAD	<p>Verify that the Slide Valve is in the AUTO mode and that capacity control is calling for loading or unloading (AUTO L or AUTO U will appear on the Operating Display).</p> <p>Output 2 controls the Slide Valve Load Soleniod. If 120 VAC is found across Wires 17 and 2, the Slide Valve Solenoid should be energized. If not, the solenoid is defective. If 120 VAC is not found when the LED for Output 2 is on, check the fuse (2FU) and/or replace the Output 2 module.</p> <p>Output 3 controls the Slide Valve Unload Solenoid. If 120 VAC is found across Wires 16 and 2, the Slide Valve Unload Solenoid should be energized. If not, the solenoid is defective. If 120 VAC is not found across Wires 16 and 2 when the LED for Output 3 is on, check the fuse (3FU) and/or replace the Output 3 module.</p> <p><i>NOTE: Verify that the proper setpoint has been programmed into Capacity Control on the Adjustable Setpoints display.</i></p>
SLIDE STOP DOES NOT INCREASE AND/OR DECREASE	<p>Verify that the Slide Stop is in the AUTO mode and that Vi Ratio is calling for a Vi increase or a Vi decrease (AUTO I or AUTO D will appear on the Operating Display).</p> <p>Output 4 controls the Slide Stop Increase Soleniod. If 120 VAC is found across Wires 15 and 2, the Slide Stop Increase Solenoid should be energized. If not, the solenoid is defective. If 120 VAC is not found across wires 15 and 2 when the LED for Output 4 is on, check the fuse (4FU) and/or replace the Output 4 module.</p> <p>Output 5 controls the Slide Stop Decrease Solenoid. If 120 VAC is found across Wires 14 and 2, the Slide Stop Decrease Solenoid should be energized. If not, the solenoid is defective. If 120 VAC is not found across Wires 14 and 2 when the LED for Output 5 is on, check the fuse (5FU) and/or replace the Output 5 module.</p>
LIQUID LEVEL ACTUATOR OPERATION	<p>Verify that switch 2SS is in the AUTO position and measure the A.C. voltage between terminals 12 (7) and 2 when the LED for Output 12 (7) is on. If 120 VAC is not found check the fuse 12FU (7FU) and/or replace the Output 12 (7) module. If 120 VAC is found, check the voltage between terminals 3 (2) and 1 with the LCV-106 enclosure. If the 120 VAC is found and the actuator is not fully closed (open), the actuator is defective. Otherwise, switch 2SS is defective.</p>
CHECKING SENSORS TE-101-102-404 403-106	<p>The Sensors are Temp. to Current Converters.</p> <p>There are NO check points/posts on the Micro P.C.B. for voltage checks.</p> <p>To check a Sensor you must swap two like Sensors and note if your problem moves or stays the same. This will tell you if you have a defective Sensor.</p> <p>You can un-plug the Sensors at the Sensor itself, DO NOT remove the Sensor wires at the terminal strip at the (SBC) Single Board Computer. P.C.B. thus causing possible poor/intermittent connections.</p>
ALARM LIGHT DOES NOT LIGHT	<p>Output 9 controls the Alarm Light. The Light should turn on only when there is a pre-alarm. If the Alarm does not Light when these conditions are found, check for 120 VAC across Wires 10 and 2. If 120 VAC is not found, check the fuse (9FU). If 120 VAC is found, replace the light bulb.</p>
CONTROL PANEL DOES NOT RESPOND TO REMOTE CONTROL SIGNALS	<p>Inputs 2 and 3 can be used to operate the compressor from a remote location.</p> <p><i>NOTE: Check the Operating Display to verify that the Slide Valve is in the REMOTE MODE.</i></p> <p>If 120 VAC is found across Wires 21 and 2, 22 and 2 and the input does not turn on, consult YORK International.</p>

SECTION
5

SYMPTOM	PROBABLE CAUSES AND CORRECTIONS
MOTOR LOAD CONTROL (FORCED UNLOAD) OCCURS AT LOW MOTOR AMPS	The current transformer is used to convert the AC motor amps to a DC voltage signal for the microprocessor. If the %FLA reading from the Operating Display is incorrect, consult YORK International.
PRESSURES ON THE OPERATING DISPLAY DO NOT APPEAR CORRECT	<p>TEST 1 – Shut down the compressor and allow pressures to equalize. Suction pressure, discharge pressure and oil pressure should have the same reading.</p> <p>TEST 2 – If either oil pressure or discharge pressure read different pressures, one or both transducers are at fault.</p> <p>Refer to Transducer Check - Testing - Troubleshooting Section - Page 26.</p>
COMPRESSOR DOES NOT AUTOMATICALLY LOAD OR UNLOAD	<p>Verify that the [AUTO] has been pressed and AUTO appears under SV Pos on the Operating Display.</p> <p>If the problem persists, see the Troubleshooting section SLIDE VALVE DOES NOT LOAD and/or UNLOAD.</p>
DISPLAY SCREENS DISPLAY SCRAMBLED PATTERN OR LISTS ALPHABET	A loose or improper connection between the displays and the SBC is indicated. Remove fuse (2FU, 10 amp) for 15 seconds and, then, restore to reset the displays.

POWER DIP

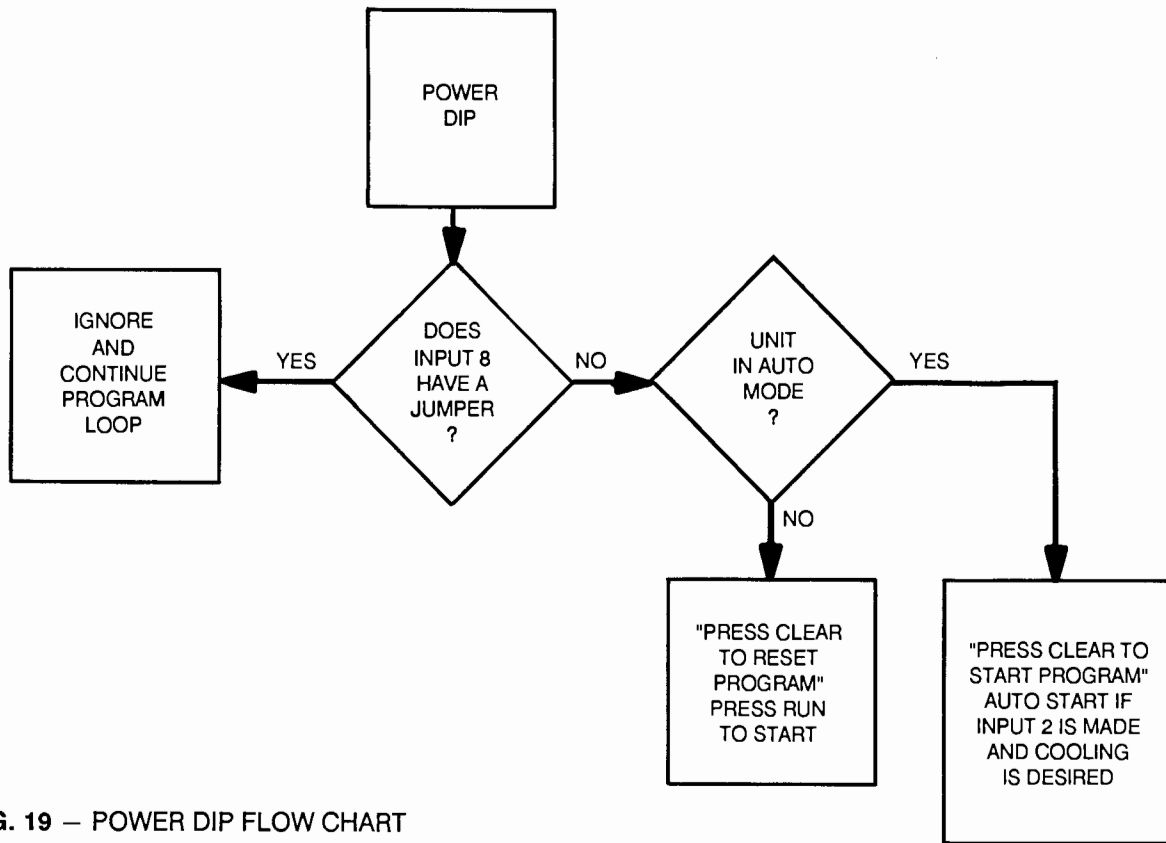

SECTION
5

FIG. 19 – POWER DIP FLOW CHART

POWER FAILURE

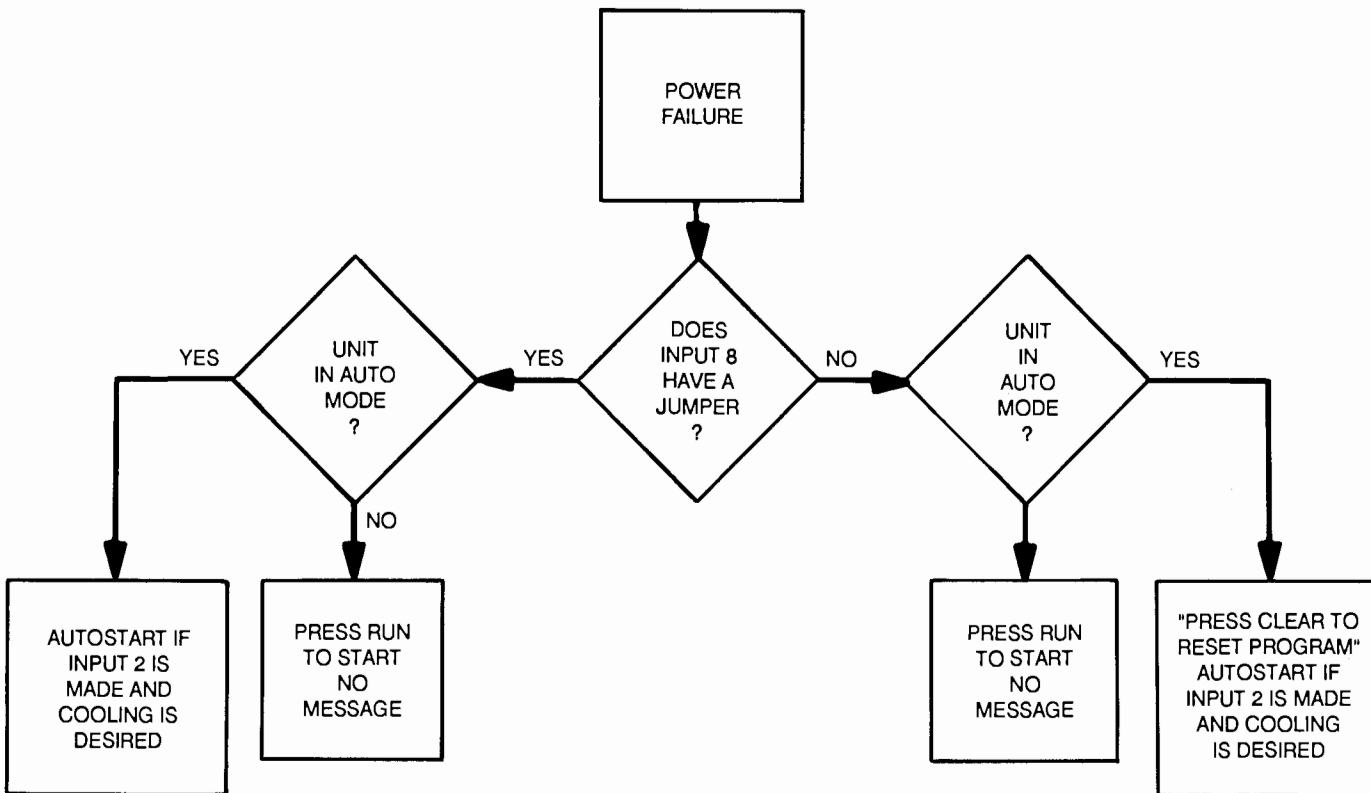
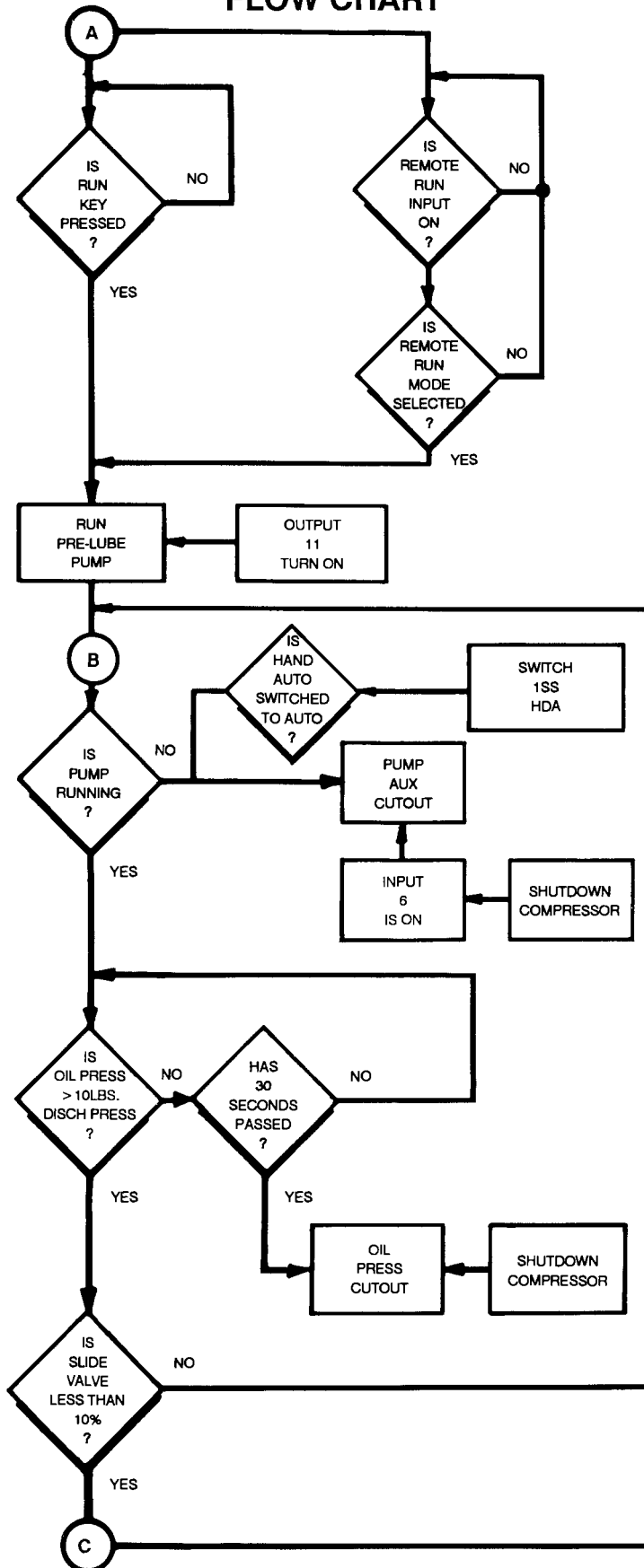

FIG. 20 – POWER FAILURE FLOW CHART

UNIT START-UP FLOW CHART



Con't to Page 33

FIG. 21 – CHILLER START-UP FLOW CHART (Cont'd on Pages 33, 34, & 35)

Con't from Page 32

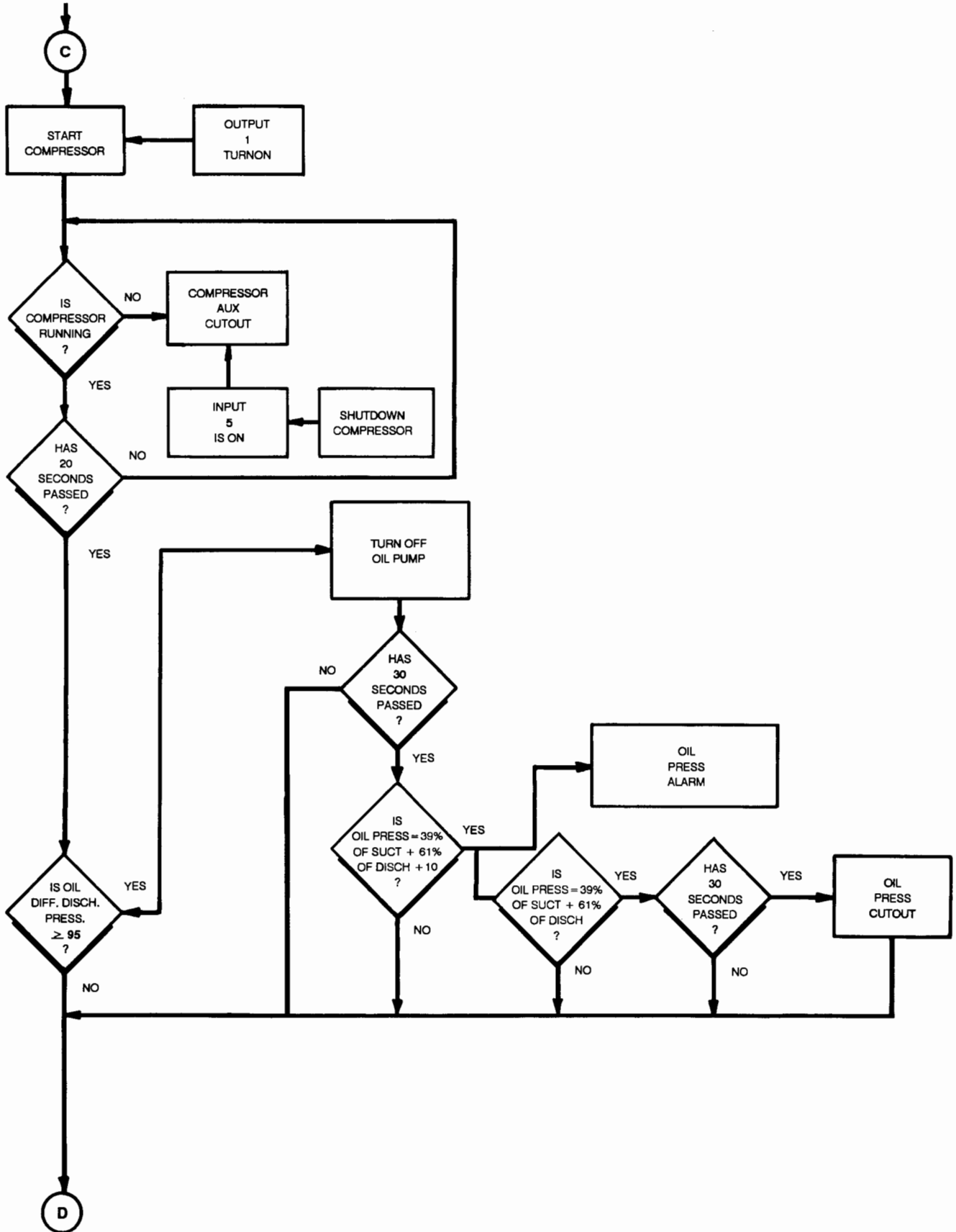

FIG. 21 – CHILLER START-UP FLOW CHART (Con't from Page 32)

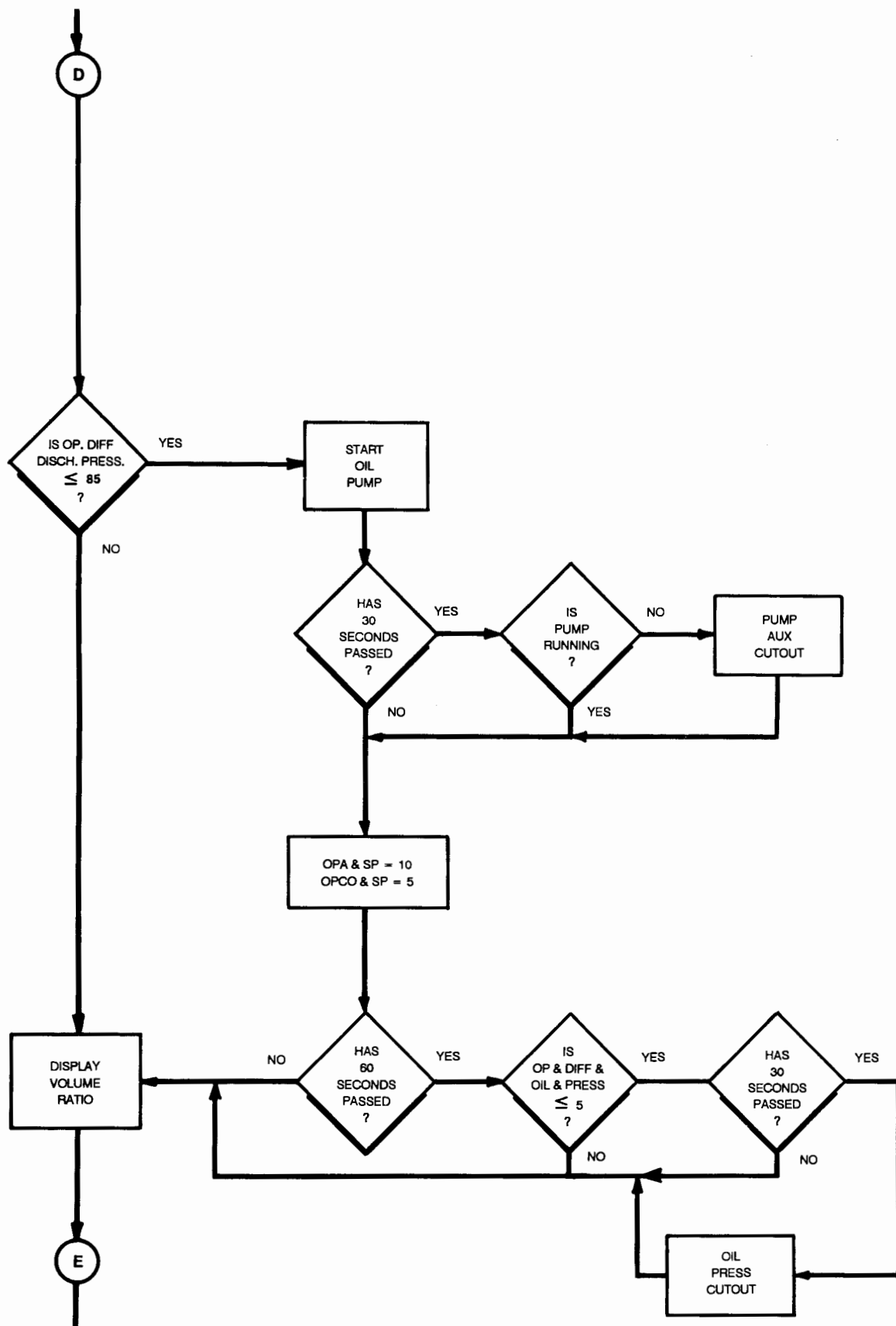

FIG. 21 – CHILLER START-UP FLOW CHART (Cont'd from Page 33)

Con't from Page 34

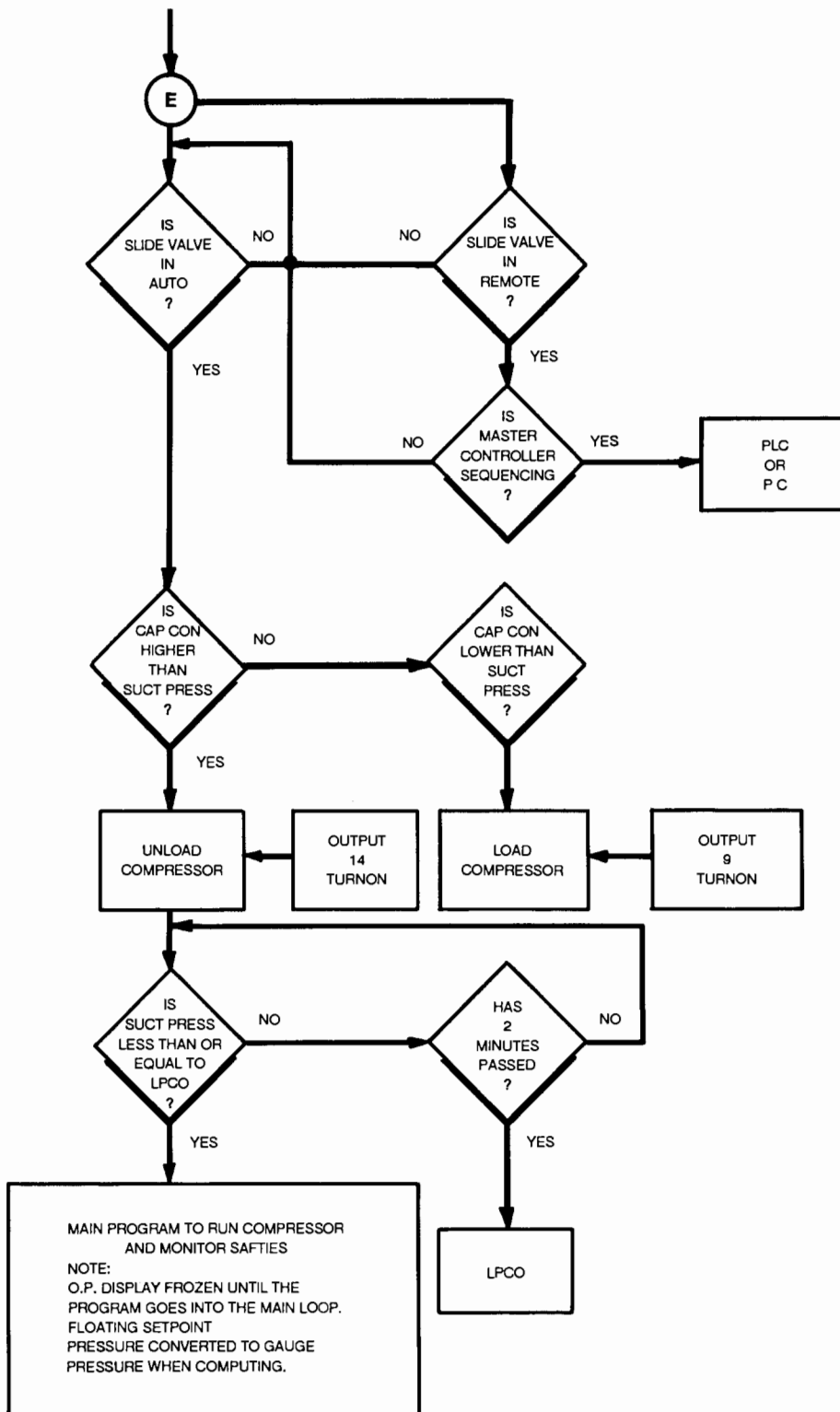

FIG. 21 – CHILLER START-UP FLOW CHART (Cont'd from Page 34)

SECTION 6 DISPLAY SCREENS

MAIN DISPLAY:	THU 01-15-89	00:43:06
Leaving Chilled Liquid Temp. -----		+047°F
Motor Current -----		090% FLA
Evaporator Pressure -----		065.8g

Condenser Pressure -----	= 230g
Oil Temp. = 120°F --- Oil Press. -----	= 250g
Current Setpoint -----	= 100%
Chilled Liquid Setpoint -----	= +045°F

ADJUSTABLE SETPOINTS:

Page #2

	Liquid Control
Liquid Setpoints:	Setpoints:

Cap. Control --- [+045°F]	Position - [050%]
Lo Liq Temp Cut [+041°F]	Dead Band [01%]
Lo Liq Temp Alr [+042°F]	Pro Band [100%]
D.B. [01°F] P.B. [10%]	

OPERATING DISPLAY:					THU 01-15-89	00:47:03
Suction	Disch	Oil	Filter	Compressor		
065.8g	230g	250g	11 PSID	Off Mode		
+070°F	185°F	127°F				

V Ratio	SV POS	Pump	%FLA	SEP 105°F
0.0	006%	Off	090%	Htr On
Auto	RMT			
Liq Temp = +047°F Liq. Level = 000%				

DISPLAY SCREENS

ADJUSTABLE SETPOINTS: ID = [01] [01-15-89]	
Page #1	Thru [01:11:10]
Lo Suct Cutout - - - [52.7g]	Baud - - - [1200]
Lo Suct Alarm - - - [55 g]	

Hi Disch Cutout - - - - - [270 g]	Flow [Shutd]	[NC]
Hi Disch Alarm - - - - - [270 g]		
M.C.L. 1 Stop Load - - - - [100%]	CT Factor - - - - - [0]	
M.C.L. 2 Force Unld - - - - [104%]	Recy. Delay - - - - [30]	

SECTION
6

FIXED SETPOINTS:	CYCLING FULL LUBE
	Oil Pump PGM/G
	Liq. Inj Con 113°F

Hi Disch Cut - - - - - [212°F]	Filter - - - - - [25]
Hi Disch Alarm - - - [194°F]	Oil Heater - - - - [113°F]
Lo Oil Temp Cut - - [49°F]	Lo Oil Cut - - - - [000]
Lo Oil Temp Alarm [58°F]	Lo Oil Alarm - - - [000]

ANNUNCIATOR: PG-1 THU 01-15-89 00:37:06
(Use STEP Key To Advance Page)
Hi Press. Cutout - - - - -
Hi Press. Alarm - - - - -

Low Press. Cutout - - - - -
Low Press. Alarm - - - - -
Oil Press. Cutout - - - - -
Oil Press. Alarm - - - - -

DISPLAY SCREENS

SHUTDOWN RECORD:	THU 01-15-89	00:38:15
Low Press. Cutout	Wed 01-14-00	02:57:19
Low Press. Cutout	Wed 01-14-00	00:56:09
Low Press. Cutout	Wed 01-14-00	00:18:09
Pump Auxiliary	Thu 01-01-00	00:45:59
Pump Auxiliary	Thu 01-01-00	00:45:13
Pump Auxiliary	Thu 01-01-00	00:41:58

FREEZE DISPLAY		

SECTION 7 TELECOMMUNICATIONS

MICROCOMPUTER CONTROL CENTER TELECOMMUNICATIONS

The YORK MicroComputer Control Center comes with an onboard telecommunications interface. The telecommunications feature permits interfacing the control center with a modem, remote data communications terminal, or master computer via RS-422 protocol. In the

case of a modem, telephone lines are used for the actual transmission of data permitting communications from a remote location.

Two RS-422 parts are provided with each control center, allowing multi-unit telecommunications through one hardware link.

SINGLE UNIT CONNECTION

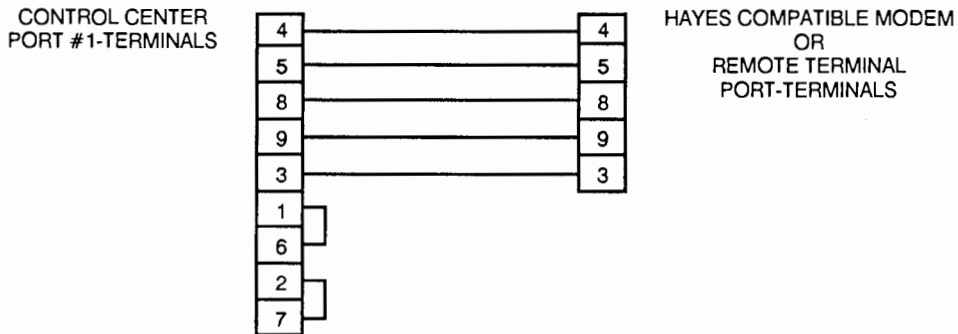

SECTION
6

SECTION
7

MULTIPLE UNIT CONNECTION

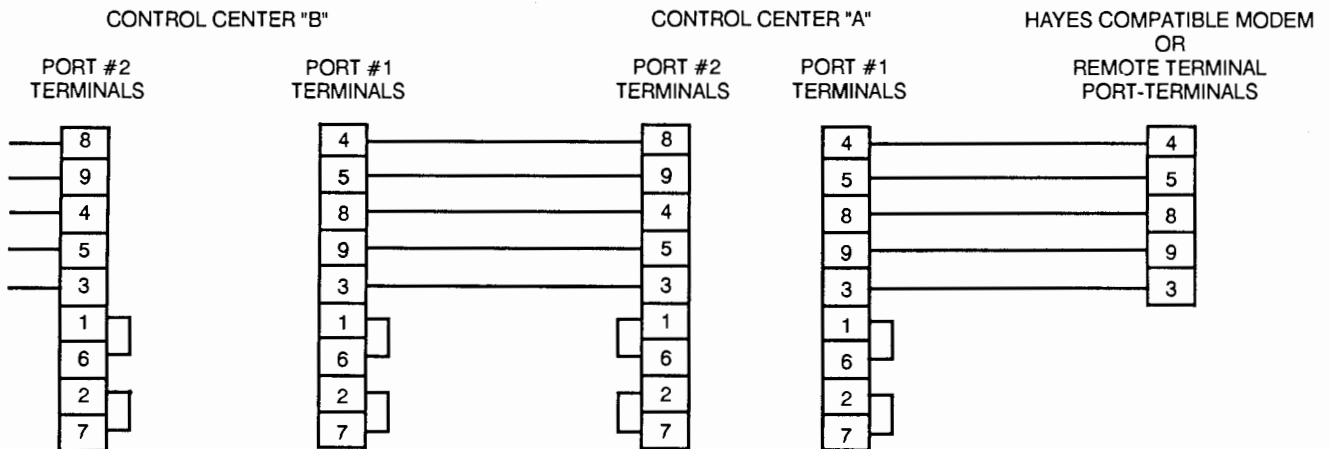

MICROCOMPUTER CONTROL CENTER RS-422 PORTS 1 AND 2 PINOUT:

PIN	IDENTIFICATION
3	Ground
2	- CTS (Clear to Send), not used
1	+ CTS (Clear to Send), not used
5	- RX (Receive)
4	+ RX (Receive)
7	- RTS (Request to Send), not used
6	+ RTS (Request to Send), not used
9	- TX (Transmit)
8	+ TX (Transmit)

FIG. 22 – TELECOMMUNICATIONS UNIT TO MODEM CONNECTIONS

UNIT IDENTIFICATION

Program the identification number of the unit on the adjustable setpoint display.

BAUD RATE

Program the baud rate desired on the adjustable setpoints display. The selectable baud rates are as follows:

300
1200
2400
4800
9600
19200

COMMUNICATIONS PROTOCOL SPECIFICATIONS

All commands must be ASCII (CAPS) to be recognized. A chiller with an ID code of [00] is considered disabled. ID codes from [01] thru [99] are valid and are recognized by the MicroComputer Control Center.

The following is a complete list of available command types.

COMMAND CODE AND DESCRIPTION

I = Returns Chiller Status Information.
R = Chiller Start Command.
S = Chiller Stop Command.
V = Chiller Slide Valve Control Command.
D = Chiller Display Screens Command.
P = Return Pressures Information.
T = Return Temperatures Information.
A = Return Full Load Amps Information.
C = Enter Change Setpoints Mode.

The following is a detailed description of each command.

RETURN CHILLER STATUS INFORMATION: #01I

Start of Command Sequence.
01 Chiller ID Code.
I Return Status Information Command.

Returned Answer:

Character Position	Description of returned data
1, 2, 3	Slide valve position.
4	R emote, A uto, M anual (slide valve)
5	A nti-recycle, R unning, O ff.
6	R em, M an, O ff, A uto (Compressor mode.)
7	C utout, A larm, N ormal.
8, 9, 10	Suction in PSIA.
11, 12	Carriage return, line feed.

CHILLER START COMMAND: #01R01

Start of command sequence.
01 Chiller ID code.
R Start chiller command.
01 Chiller ID code repeated for verification.

NOTE: The chiller must be in the remote start mode for this command to be executed by the microprocessor.

Returned Answer: A01

Character Position	Description of returned data
1	Acknowledge of command sent.
2, 3	ID code of compressor.
4, 5	Carriage return, line feed.

CHILLER STOP COMMAND: #01S01

Start of command sequence.
01 Chiller ID code.
S Stop chiller command.
01 Chiller ID code repeated for verification.

NOTE: The chiller must be in the remote start mode for this command to be executed by the microprocessor.

Returned Answer: A01

Character Position	Description of returned data
1	Acknowledge of command sent.
2, 3	ID code of chiller.
4, 5	Carriage return, line feed.

CHILLER SLIDE VALVE

CONTROL COMMAND: #01VLXX
UXX
S

Start command sequence.
01 Chiller ID code.
V Chiller control command.
L Load slide valve command.
U Unload slide valve command.
S Return slide valve position value.
XX Two Numeric ASCII Digits (Used With L/U Commands)
XX = 00 Turns selected output off.
XX = 01 to 15 Turns selected output on for XX Sec.
XX = 99 Turns selected output on.

If the command was #01VL00, then the load slide valve output on chiller #1 would be turned off. If the command was #01VL05, then the load slide valve output on chiller #1 would be turned off for 5 seconds, and would then automatically turn off. NOTE: the slide valve must be in the remote mode for this command to be executed.

Returned Answer: (for L/U commands): A01

Character Position	Description of returned data
1	Acknowledge of command sent.
2, 3	ID code of compressor.
4, 5	Carriage return, line feed.

Character Position	Description of returned data
1, 2, 3	3 ASCII characters representing the slide valve position.

CHILLER DISPLAY SCREENS COMMAND:#01DXN

Start of command sequence.
01 Chiller ID code.
N Chiller control command.

X = M Main display.
X = O Operating display.
X = S Adjustable setpoints display. PG #1
X = X Fixed setpoints display.
X = R Shutdown record display.
X = F Freeze display.
X = C Aut cycle display.
X = P Security display.
X = B Adjustable setpoints display. PG #2
X = AN Annunciator display page N.

NOTE: The "N" parameter is used only to access the Annunciator display pages 1 thru 4.

AN N = 1 Display page #1
N = 2 Display page #2
N = 3 Display page #3
N = 4 Display page #4

If the command was #01DA1, then the microprocessor would dump the annunciator display page #1. Display dumps consist of 336 characters each.

RETURN PRESSURES COMMAND: #01PX

Start command sequence.
01 Chiller pressures command.
P Return pressures command.

X = S Return suction pressure.
X = D Return discharge pressure.
X = O Return oil pressure.
X = F Return filter differential pressure.
X = A Return all pressures as a string of data.

If the command was #01PS, then the microprocessor would dump the suction pressure.

Returned answer:

XXX = 3 characters followed by a carriage return, line feed.

If using the "A" command, then the returned data would be:

XXXXXXXXXXXX = 12 characters followed by a carriage return, line feed.

RETURN TEMPERATURES COMMAND: #01TX

Start of command sequence.
01 Chiller ID code.
T Return temperature command.

X=S Return suction temperature.
X=D Return discharge temperature.
X=O Return oil temperature.
X=P Return separator temperature.
X=A Return all temperatures as a string of data.

If the command was #01TS, then the microprocessor would dump the suction temperature.

Returned answer:

XXX = 3 Characters followed by a carriage return, line feed

If using the "A" command, then the returned data would be:

XXXXXXXXXXXX = 12 Characters followed by a carriage return, line feed.

RETURN FULL LOAD AMPS COMMAND: #01A

Start of command sequence.
01 Chiller ID code.
A Return full load amps command.

If the command was #01A, then the microprocessor would dump the full load amps value.

Returned answer:

XXX = 3 Characters followed by a carriage return, line feed

CHANGE SETPOINTS COMMAND: #01C

Start of command sequence.
01 Chiller ID code.
C Enter change setpoints command

The following is the complete list of the setpoints that may be changed while in the change setpoints mode:

LCCS --- Liquid capacity control setpoint.
LPA ----- Low pressure alarm.
HPCO --- High pressure cutout.
HPA ----- High pressure alarm.

If the command was #01C, then the microprocessor would dump the prompt for the first setpoint which is LCCS = 045 /. Pressing the "N" Key will step the Microprocessor to the next setpoint. After the prompt, the computer is expecting the operator to enter 3 numeric characters. When entering setpoints for LPCO, and LPA, the computer will expect the letter "G" to be entered after the 3 characters have been entered. G indicates pounds per square inch gauge (g). To exit the change setpoints mode, simply send the next command preceded with a "#" character code.

SECTION
7

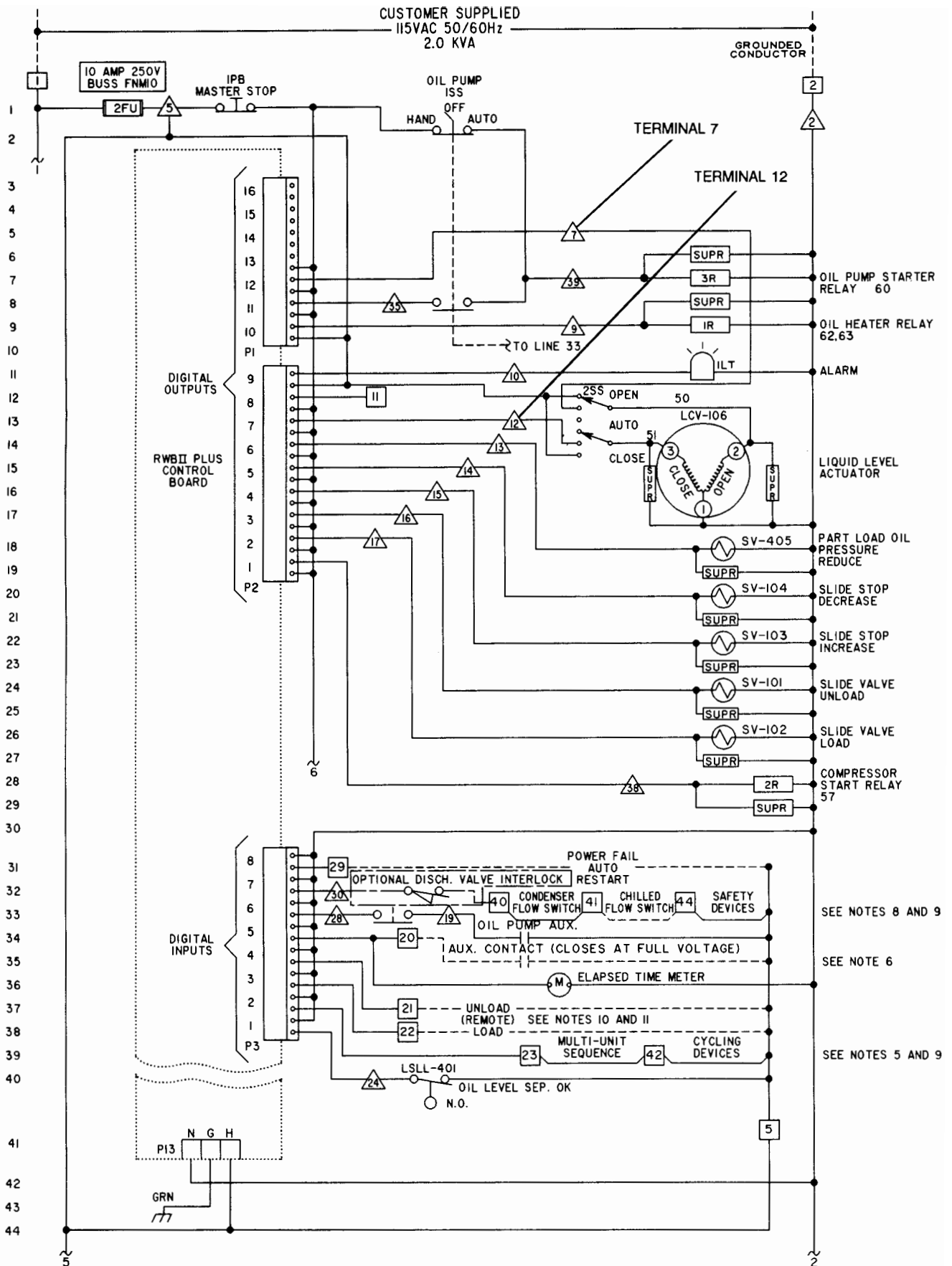

FIG. 23 – ELEMENTARY DIAGRAM SHOWING LOCATION OF TERMINALS 7 AND 12



P.O. Box 1592, York, Pennsylvania USA 17405-1592
Copyright © by York International Corporation 1997
FORM 160.65-OM1 (290)

Subject to change without notice. Printed in USA
ALL RIGHTS RESERVED
POS 500 897 3.08
CODE: RSC & SK