

MODEL YS NN NN S7 (STYLE A)

COOLING

1000 THRU 1250 TONS

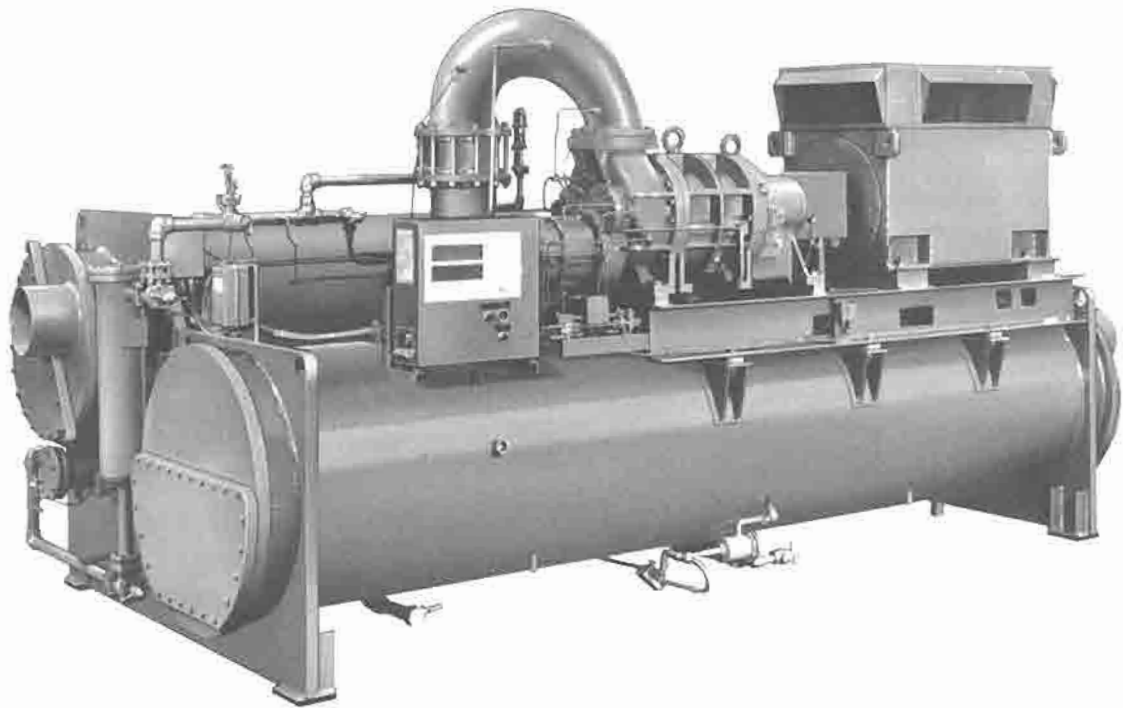

REFERENCE INSTRUCTIONS

- | | |
|-------------|--|
| 50.15-NM | — SHIPPING DAMAGE CLAIMS |
| SEE TABLE 1 | — PRODUCT DRAWINGS |
| 160.65-CL1 | — INSTALLATION CHECK LIST AND REQUEST FOR START-UP |
| 160.65-N1.2 | — FIELD ASSEMBLY OF CODEPAK |

TABLE OF CONTENTS

RIGGING DATA—OVERALL DIMENSIONS & WEIGHTS	2
INTRODUCTION	3
GENERAL	3
FIELD ASSEMBLED UNITS ONLY	3
CONSTRUCTION DRAWINGS (PRODUCT DRAWINGS)	3
SHIPMENT	4
INSPECTION—DAMAGE—SHORTAGE	4
CODEPAK DATA PLATE	4
RIGGING	4-5
USE OF SLINGS	5
LOCATION	5
FOUNDATION	5
CLEARANCE	5
INSTALLATION	8
RIGGING UNIT TO FINAL LOCATION	8
LOCATING AND INSTALLING ISOLATION MOUNTS	8
CHECKING ISOLATION PAD DEFLECTION	8
CHECKING UNIT LEVEL	8
LOCATING AND INSTALLING OPTIONAL SPRING ISOLATORS	8-9
PIPING CONNECTIONS	9
COOLER AND CONDENSER WATER PIPING	9-10
REFRIGERANT RELIEF PIPING	11
UNIT PIPING	11-12
REFRIGERANT TRANSFER UNIT WATER CONNECTIONS	12
CONTROL WIRING	12
POWER WIRING	12
CODEPAK WITH ELECTRO-MECHANICAL STARTER	12
OIL PUMP 3 PHASE STARTER AND TRANSFER UNIT	13
YS MOTORS (ELECTRO-MECHANICAL STARTER)	13
INSULATION	13
INSTALLATION CHECK—REQUEST FOR START-UP SERVICE	14

RIGGING DATA OVERALL DIMENSIONS & WEIGHTS

Overall dimensions and weights are shown in Product Drawings furnished with each unit in the instruction

packet. The Product Drawing for the unit involved is Form 160.65-PA1.1.

INTRODUCTION

GENERAL

This instruction describes the installation of a MODEL YS CODEPAK Rotary Screw Liquid Chiller. This unit is shipped as a single factory assembled, piped, wired and nitrogen charged package requiring a minimum of field labor to make chilled water connections, condenser water connections, refrigerant atmospheric relief connections, and electrical power connections.

CODEPAKS can also be shipped dismantled when required by rigging conditions, but generally it is more economical to enlarge access openings to accommodate the factory assembled unit. CODEPAKS shipped dismantled **MUST** be field assembled under the supervision of a YORK representative, but otherwise installation will be as described in this instruction.

FIELD ASSEMBLED UNITS ONLY

Use Form 160.65-N1.2 system piping and electrical system drawings in conjunction with this installation instruction. The field assembly instruction will be furnished with all units that are to be field assembled. Extra copies may be ordered from the YORK Publications Distribution Center.

CONSTRUCTION DRAWINGS

Construction drawings are furnished for each job as noted in Table 1. These drawings must be carefully followed and used in conjunction with this installation instruction, to insure proper installation of the unit. In

event of any differences between drawings and this instruction, the drawings shall govern.

The services of a YORK representative (in accordance with the contract price) will be furnished to check the installation, supervise the initial start-up and operation of all CODEPAKS.

CAUTION: The YORK Warranty will be voided if the following restrictions are not adhered to:

1. No valves or connections should be opened under any circumstances because such action will result in loss of the factory nitrogen charge.
2. Do not dismantle or open the CODEPAK for any reason except under the supervision of a YORK representative.
3. When units are shipped dismantled, notify the nearest YORK office in ample time for a YORK representative to supervise rigging the unit to its operating position and the assembly of components.
4. Do not make final power supply connections to the compressor motor or control center.
5. Do not charge the compressor with oil.
6. Do not attempt to start the system.
7. Do not run hot water (110°F max.) or steam through the cooler or condenser at any time.

TABLE 1 – CONSTRUCTION DRAWINGS (PRODUCT DRAWINGS) ISSUED BY THE YORK SALES OFFICE

DESCRIPTION	PRODUCT DRAWING (FORM NO.)
	YS NN NN S7 – COOLING
DIMENSIONS, PHYSICAL DATA & INSULATION INSTRUCTIONS	160.65-PA1.1
WIRING DIAGRAM MICROCOMPUTER CONTROL CENTER	160.65-PA2.1
FIELD WIRING	160.65-PA3.2
FIELD CONTROL MODIFICATIONS	160.65-PA4.1
MOTOR STARTER SPECIFICATIONS ELECTRO-MECHANICAL STARTER	160.65-PA5.1

SHIPMENT

The CODEPAK is shipped in the following forms:

YS CODEPAK

- Form 2 – Standard for U.S.A. Complete with motor and not charged with refrigerant, but with a holding charge of nitrogen. Refrigerant shipped in 125 lb., and 1750 lb. cylinders.
- Form 3 – Complete with motor, but dismantled. Refrigerant shipped in 125 lb., and 1750 cylinders.
- Form 7 – Split Shells - Complete with motor but dismantled with shells not assembled. Refrigerant shipped in 125 lb. and 1750 cylinders.

FACTORY ASSEMBLED UNIT

1. The motor/compressor assembly is mounted on top of the cooler, and the refrigerant transfer unit is mounted on top of condenser with all necessary interconnecting piping assembled. MicroComputer Control Center and oil pump starter are mounted on the unit. Complete unit is factory leak tested, evacuated and charged with nitrogen gas.
2. Miscellaneous material-Four (4) vibration isolation pads (or spring isolators and brackets for YS units). Necessary refrigerant in Quantity of 7 (125 lb. cylinders) and Quantity of 2 (1750 lb. cylinders). Initial oil charge.

DISMANTLED UNIT

(REFER TO INSTRUCTION FORM 160.65-N1.2)

1. a. Motor/compressor assembly.
b. Shell assembly. (Cooler and Condenser)
c. Necessary factory fabricated interconnecting refrigerant piping.
d. Refrigerant - 22, charge, (125 lb. and 1750 lb. cylinders).
e. Refrigerant Transfer unit.
f. Split Shells (Form 7 only).
2. Control Center – MicroComputer, as required with interconnecting wiring. Removed for shipment.
3. Miscellaneous Material same as Factory Assembled Unit plus necessary nuts, bolts and gaskets; material for connections to unit.

When more than one CODEPAK is involved, the major parts of each unit will be marked to prevent mixing of assemblies.

INSPECTION – DAMAGE – SHORTAGE

The unit shipment should be checked on arrival to see that all major pieces, boxes and crates are received. Each unit should be checked on the trailer or rail car when received, before unloading, for any visible signs of damage. Any damage or signs of possible damage must be reported to the transportation company immediately for their inspection.

YORK WILL NOT BE RESPONSIBLE FOR ANY DAMAGE IN SHIPMENT OR AT JOB SITE OR LOSS OF PARTS. (Refer to Shipping Damage Claims, Form 50.15-NM.)

When received at the job site all containers should be opened and contents checked against the packing list. Any material shortage should be reported to YORK immediately. (Refer to Shipping Damage Claims, Form 50.15-NM.)

CODEPAK DATA PLATE

A unit data plate is mounted on the MicroComputer Control Center assembly of each unit, giving unit model number; design working pressure; water passes; refrigerant charge; serial numbers; and motor power characteristics.

RIGGING

The complete standard CODEPAK is shipped without skids. (When optional skids are used it may be necessary to remove the skids so riggers skates can be used under the unit end sheets to reduce overall height.

Each unit has eight (8) lifting holes, (4) four on each end, in the end sheets. The four (4) outside corner holes must be used for lifting the unit. (See Fig. 1.)

Care should be taken at all times during rigging and handling of the CODEPAK to avoid damage to the unit and its external connections. Lift only using the outside corner holes provided. Do not lift the unit with slings around motor/compressor assembly or by means of eyebolts in the tapped holes of the compressor motor assembly. Do not turn a unit on its side for rigging. Do not rig vertically.

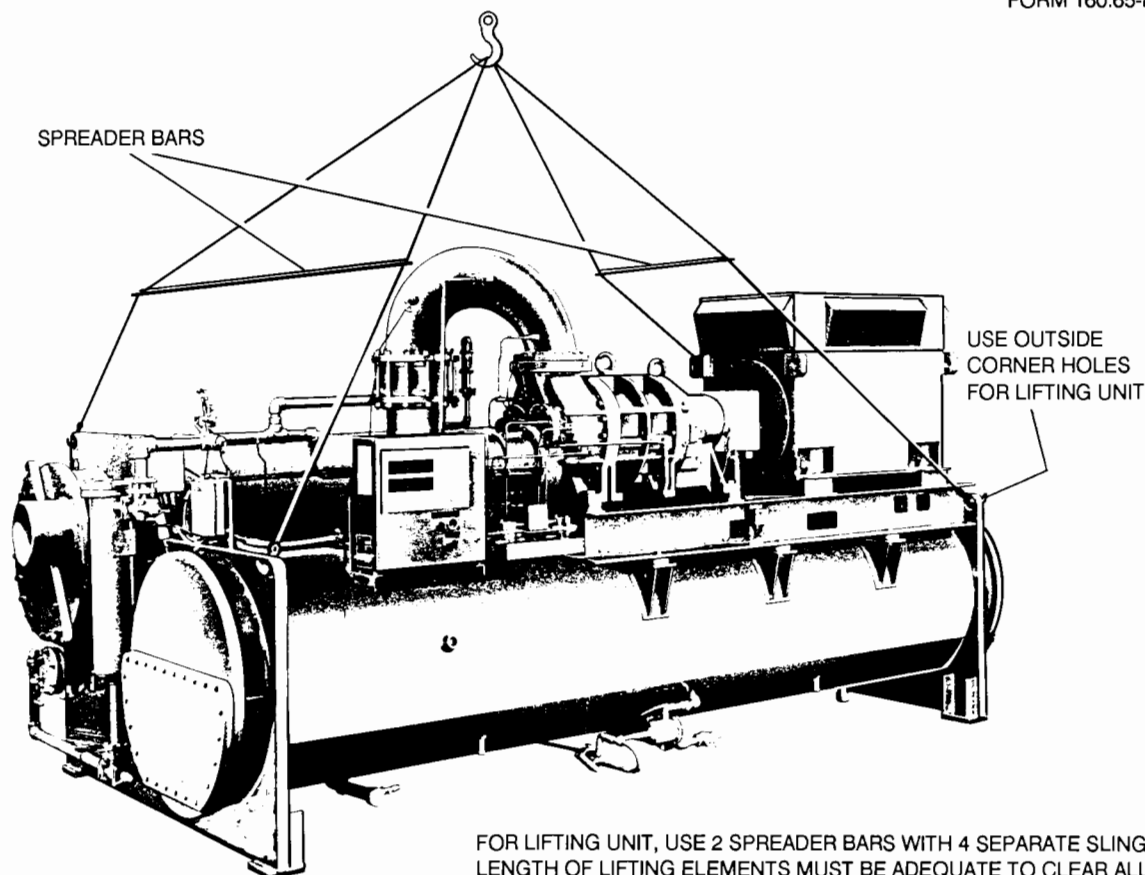

FIG. 1 – RIGGING THE UNIT

USE OF SLINGS

(See Fig. 1 for proper use of slings in rigging.)

CAUTION: If necessary to rig the CODEPAK by one end to permit lifting or dropping through a vertical passage-way, such as an elevator shaft, contact YORK before factory shipping for special rigging instructions.

The rigging and operating weights and overall dimensions are given in the proper Product Drawing Form 160.65-PA1.1, page 6, as a guide in determining the clearances required for rigging. (Add 6" to overall height for optional skidded unit.)

LOCATION

YORK CODEPAKS are furnished with vibration isolator mounts for basement or ground level installations. Units may be located on upper floor levels providing the floor is capable of supporting the total unit operating weight and optional spring isolators are used.

IMPORTANT

Sufficient clearance to facilitate normal service and maintenance work must be provided all around and above the unit, and particularly space provided at either end to permit cleaning or replacement of cooler and condenser tubes see CLEARANCE on Product Drawings furnished with each job. A doorway or other sufficiently large opening properly located may be used. Equipment room should be ventilated to allow heat removal approximately 2 or 3 air changes per minute. Check state, local and other codes. The chiller should be located in an indoor location where temperatures range from 40°F to 110°F.

FOUNDATION

A level floor, mounting pad or foundation must be provided by others, capable of supporting the operating weight of the unit. (See Product Drawings Forms 160.65-PA1.1 for floor layout.)

CLEARANCE

Clearances should be adhered to as follows:

2 ft. – Rear, ends and above unit.

3 ft. – Front of unit.

Tube Removal – Space 16'-4" either end.
See Product Drawings.

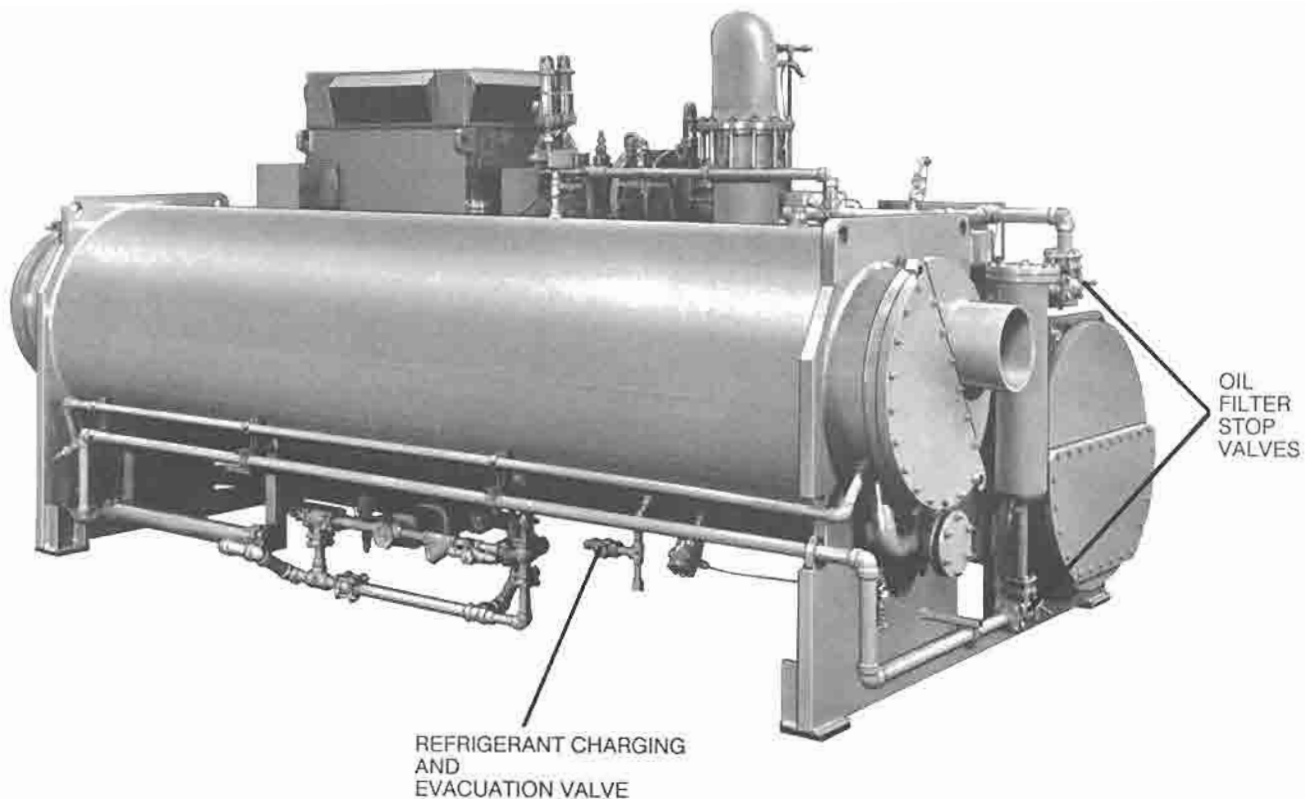

FIG 2 – CODEPAK MODEL YS - REAR VIEW - L. H. END

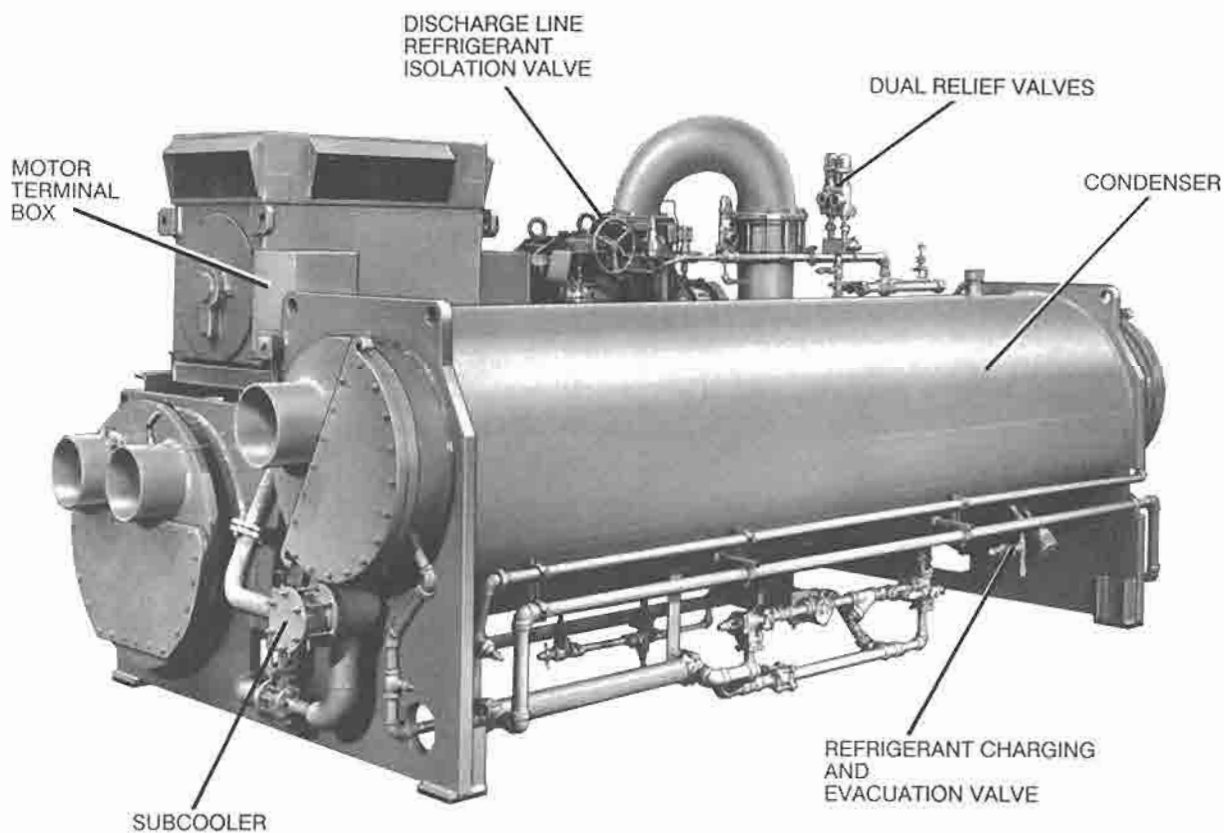

FIG. 3 – CODEPAK MODEL YS - REAR VIEW - R. H. END

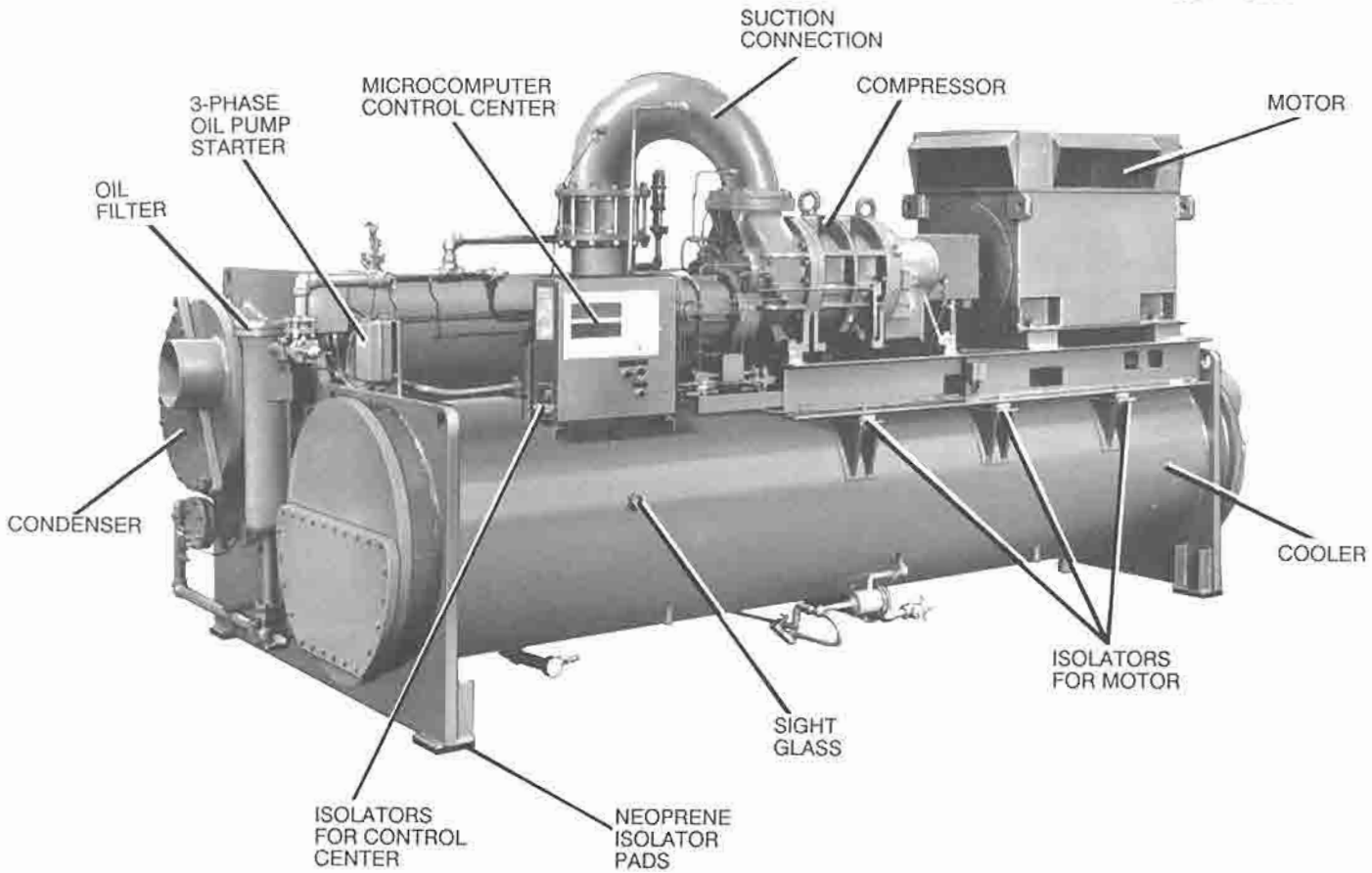

FIG 4 – CODEPAK MODEL YS - FRONT VIEW - L. H. END

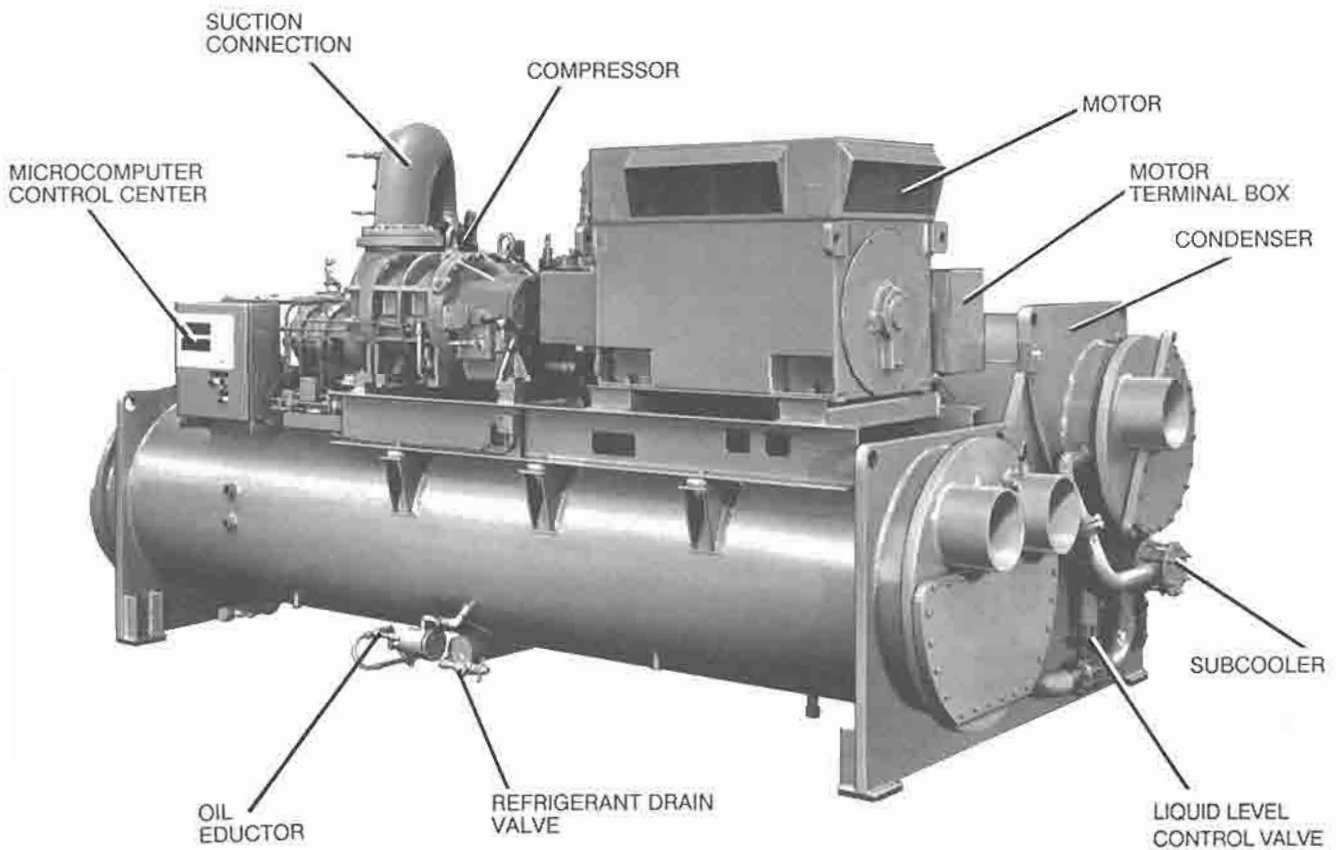

FIG. 5 – CODEPAK MODEL YS - FRONT VIEW - R.H. END

INSTALLATION

RIGGING UNIT TO FINAL LOCATION

Rig the unit to its final location on the floor or mounting pad. Lift the unit (or shell assembly) by means of an overhead lift and lower the unit to its mounting position. (If optional shipping skids are used remove them before lowering the CODEPAK to its mounting position.)

NOTE: At this point units shipped dismantled should be assembled under the supervision of a YORK representative.

If cooler is to be field insulated, the insulation should be applied to the cooler before the unit is placed in position while the unit is in the lift position.

LOCATING AND INSTALLING ISOLATOR PADS (REFER TO FIG. 6)

The isolator pads should be located in accordance with the floor layout on the Dimensional Product Drawing.

chiller both longitudinally and transversely. (See CHECKING THE UNIT LEVEL.)

The unit should be level within 1/4" from one end to the other end and from front to the rear. If the chiller is not level within the amount specified, lift it and place shims between the isolation pad and the CODEPAK shell foot support. (Shims furnished by the installer.) Lower unit again and recheck its level.

Checking The Isolation Pad Deflection

All isolation pads should be checked for the proper deflection while checking the level for the CODEPAK. Each pad should be deflected approximately 0.15 inch. If an isolation pad is under deflected, shims should be placed between the unit metal mounting and the top of the isolator pad to equally deflect all pads.

Checking The Unit Level

The longitudinal alignment of the unit should be checked by placing a level on the top center of the cooler shell under the compressor/motor assembly. Transverse alignment should be checked by placing a level on top of the shell end sheets at each end of the CODEPAK.

LOCATING AND INSTALLING OPTIONAL SPRING ISOLATORS

(Refer to Fig. 7 & Form 160.65-PA1.1)

Install the four (4) high efficiency spring vibration isolator assemblies on the unit after the unit has been properly located. Assemble the optional spring isolators per Fig. 7. After assembly of the spring isolators has been completed turn down the jacking screw of each isolator until the bottom of the shell foot support is about 7/8" of the floor. The isolator jacking screws should be well lubricated when received from the factory. If the screws are not well lubricated the following lubricants are recommended:

G.E. G-697 Silicone grease or Mobilprex No. 47.

The longitudinal alignment of the unit should be checked by placing a level on the top of each shell about the center of the unit. The transverse alignment should be checked by placing a level on top of the permanent tube sheets. Adjust the jacking screws so the unit is level in both directions.

If the jacking screws are not long enough to level unit due to an uneven or sloping floor or foundation, steel shims (grouted, if necessary) must be added beneath the isolator assemblies as necessary.

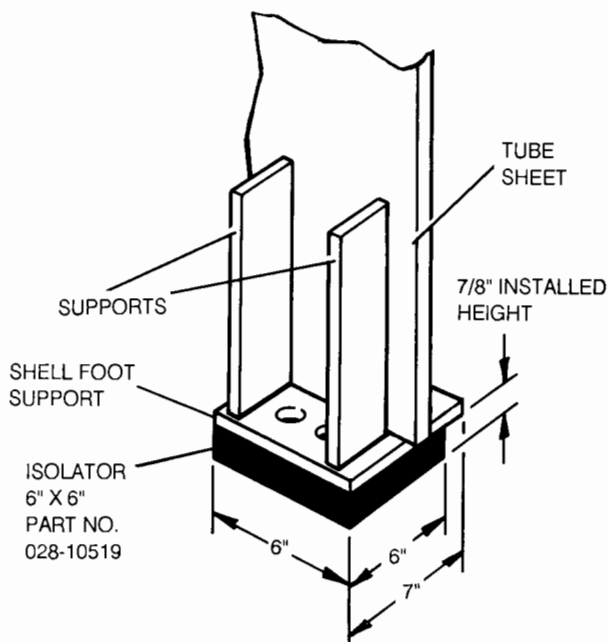

FIG. 6 — STANDARD NEOPRENE VIBRATION ISOLATOR PAD MOUNTS

After the isolator pad mounts have been placed into position on the floor, lower the CODEPAK onto the pads. Make sure the pads are even with the edges of the CODEPAK mounting feet. When the unit is in place remove the rigging equipment and check the level of the

6 $\frac{3}{8}$ " X 9 $\frac{1}{2}$ "
 SPRING ISOLATOR
 MOUNTS AND
 BRACKETS

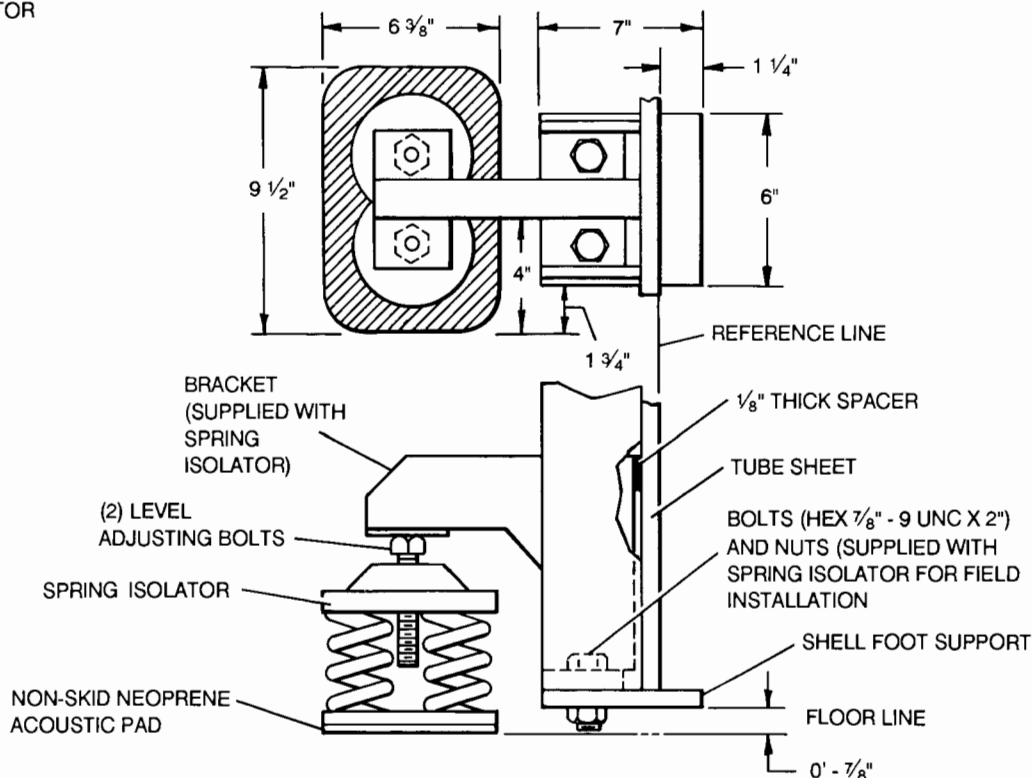

FIG. 7 – INSTALLATION AND ADJUSTMENT OF (OPTIONAL) SPRING ISOLATORS

After the unit is leveled wedge and shim under each end of support (tube sheet), to solidly support the unit in this position while piping connections are being made, pipe hangers adjusted and connections checked for alignment. (See Piping Connections). Then the waterboxes are filled with water and checked for leaks. The jacking screws should now be finally adjusted until the wedges and shims can be removed. The unit should now be in correct level position, clear to the floor or foundation and without any effect from the weight of the piping. When the unit is properly supported, spring isolator installed height to top surface of isolator top plate will be 4-1/2 to 4-3/4 inches.

PIPING CONNECTIONS

After the unit is leveled (and wedged in place for optional spring isolators) the piping connections may be made up; chilled water, condenser water and refrigerant relief valves and the compressor bursting disc connection. The piping should be arranged with offsets for flexibility, and adequately supported and braced independently of the unit to avoid strain on the unit and vibration transmission. Hangers must allow for alignment of pipe. Isolators (by others) in the piping and hangers are highly desirable, and may be required by specifications, in order to effectively utilize the vibration isolation characteristics of the vibration isolation mounts of the unit.

Check for piping alignment—Upon completion of piping, a connection in each line as close to the unit as possible should be opened, by removing the flange bolts or coupling and checked for piping alignment. If any of the bolts are bound in their holes, or if the connection springs out of alignment, the misalignment must be corrected by properly supporting the piping or by applying heat to anneal the pipe.

NOTE: If the piping is annealed to relieve stress, the inside of the pipe must be cleaned of scale before it is finally bolted in place.

COOLER AND CONDENSER WATER PIPING

The cooler and condenser liquid heads of CODEPAK units have 12" long nozzles suitable for cut off and welding 150 psig DWP flanges. The nozzles and water pass arrangements are furnished in accordance with the job requirements (see Product Drawing Form 160.65-PA1.1 referenced in Table 1, page 3) furnished with the job. Standard units are designed for 150 psig DWP on the water side. If job requirements are for greater than 150 psig DWP, check the unit data plate before applying pressure to cooler or condenser to determine if the CODEPAK has provisions for the required DWP.

Cooler

Chilled water must leave the cooler through the connection marked "Liquid Outlet".

Foreign objects which could lodge in or block flow through, the cooler and condenser tubes must be kept out of the water circuit. All water piping must be cleaned or flushed before being connected to the CODEPAK, pumps, or other equipment.

Permanent strainers (by others) are required in both the cooler and condenser water circuits to protect the CODEPAK as well as the pumps, tower spray nozzles, chilled water coils and controls, etc.

A strainer, meeting YORK specifications should be installed in the entering chilled water line, directly upstream of the CODEPAK.

If pumps discharge through the CODEPAK, the strainer may be located upstream from pumps to protect both pump and CODEPAK. (Piping between strainer, pump and CODEPAK must be very carefully cleaned before startup.) If pumps are remotely installed from CODEPAK, strainers should be located directly upstream of the CODEPAK.

Condenser Water Circuit

For proper operation of the unit, condenser refrigerant pressure must be maintained above cooler pressure. If operating conditions will fulfill this requirement, no attempt should be made to control condenser water temperature by means of automatic valves, cycling of the cooling tower fan or other means, since CODEPAKS

are designed to function satisfactorily and efficiently when condenser water is allowed to seek its own temperature level at reduced loads and off-peak seasons of the year. However, if entering condenser water temperature can go below the required minimum, (refer to Form 160.65-O1) condenser water temperature must be maintained equal to or slightly higher than the required minimum. Refer to Fig. 8 for typical water piping schematic for cooling CODEPAK.

Stop Valves

Stop valves may be provided (by others) in the cooler and condenser water piping adjacent to the unit to facilitate maintenance. Thermometer wells and pressure taps should be provided (by others) in the piping as close to the unit as possible to facilitate operating checks.

Flow Switches (Field Installed)

A flow switch or pressure differential control in the chilled water line(s) adjacent to the unit is an accessory furnished for connection to the control center. If a flow switch is used, it must be directly in series with the CODEPAK and sensing only water flow through the CODEPAK. The differential switch must sense pressure drop across the unit.

Drain and Vent Valves

Drain and vent valves (by others) should be installed in the connections provided in the cooler and condenser liquid heads. These drain connections may be piped to building drain if desired.

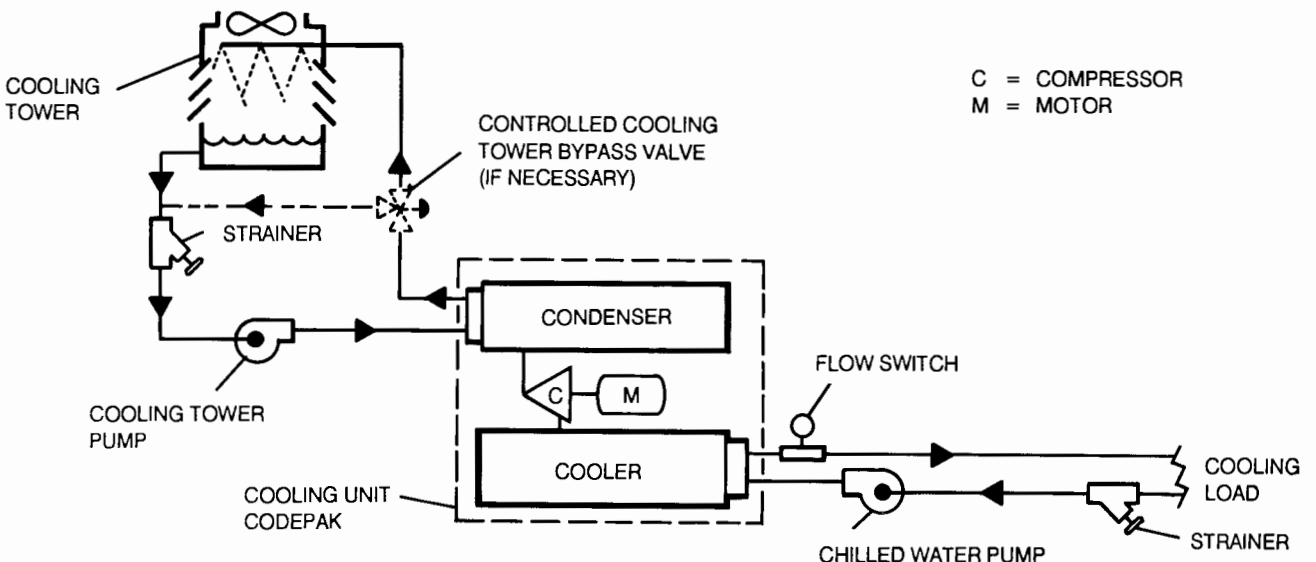

FIG. 8 — SCHEMATIC OF A TYPICAL PIPING ARRANGEMENT FOR COOLING ONLY CODEPAKS

Checking Piping Circuits and Venting Air

After the water piping is completed, but before any water box insulation is applied, tighten and torque (to maintain between 30 and 60 ft. lbs.) the nuts on the liquid head flanges. Gasket shrinkage and handling during transit cause nuts to loosen. If water pressure is applied before this is done, the gaskets may be damaged and may have to be replaced. Fill the chilled and condenser water circuits, operate the pumps manually and carefully check the cooler and condenser water heads and piping for leaks. Repair leaks as necessary.

Before initial operation of the unit both water circuits (or all three water circuits heat recovery units) should be thoroughly vented of all air at the high points.

REFRIGERANT RELIEF PIPING (REFER TO FIG'S. 9 AND 10)

Each unit is equipped with a frangible carbon bursting disc assembly piped from the bottom of the compressor. 1-1/2" dual relief valves located on top of condenser and a single 1-1/2" relief valve located underneath the suction line check valve for the purpose of quickly relieving excess pressure of the refrigerant charge to outside of

room venting system as a safety precaution in case of an emergency, such as fire. The bursting disk is furnished in accordance with ANSI/ASHRAE-15 and is set to relieve at 500 psig.

Refrigerant relief vent piping (by others), from the bursting disk and relief valves to the outside of the equipment room venting system is required by code in most areas and should be installed on all CODEPAKS. The vent line should be sized in accordance with the ANSI/ASHRE-15, or local code, **but should never be smaller than the 2" bursting disk connection.** (See Fig.'s 9 and 10.) The vent line must include a dirt trap in the vertical leg to intercept and permit clean out of bursting disk fragments in the event of disk rupture and to trap any vent stack condensation (See Fig. 10). The piping **MUST** be arranged to avoid strain on the bursting disk, using a flexible connection, if necessary and must be removable for replacement of bursting disk.

DO NOT LOOSEN FLANGES THAT CONTAIN BURSTING DISK ASSEMBLY. Otherwise, refrigerant will be lost or moisture will enter the unit. Do not hit or contact the carbon bursting disk with any object. The bursting disk will break causing refrigerant to escape and moisture to enter the unit.

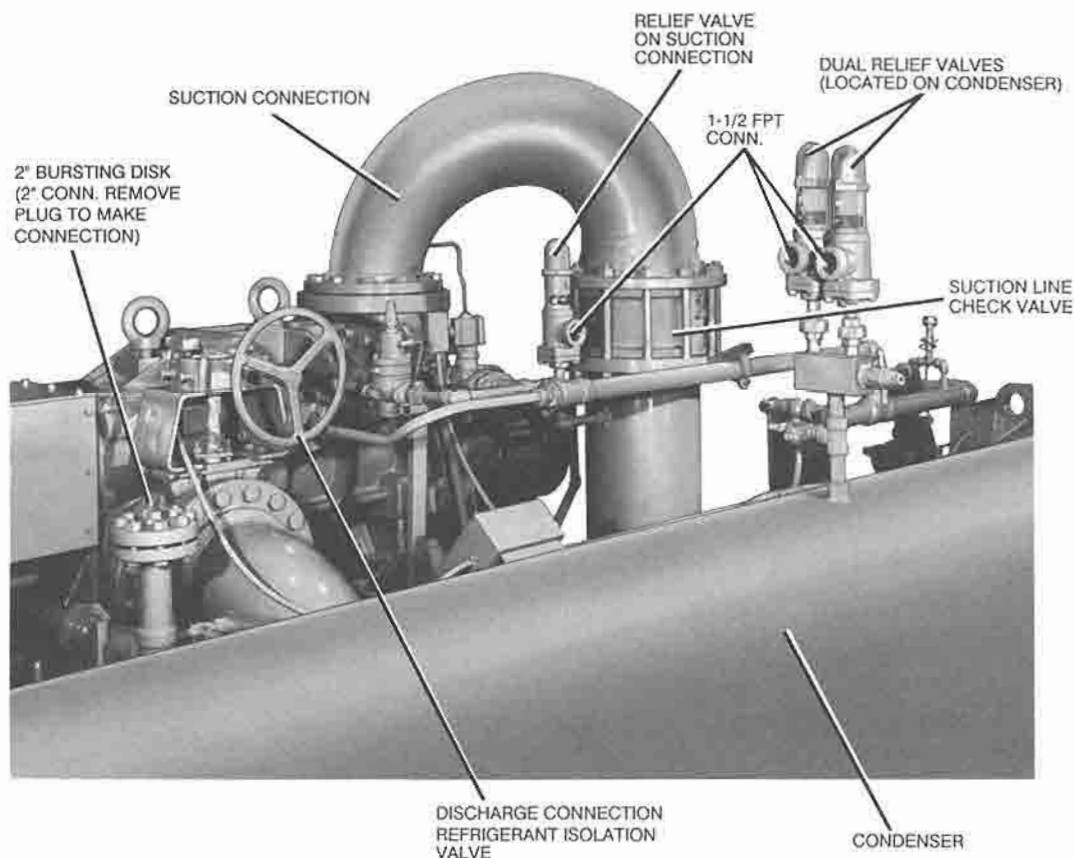
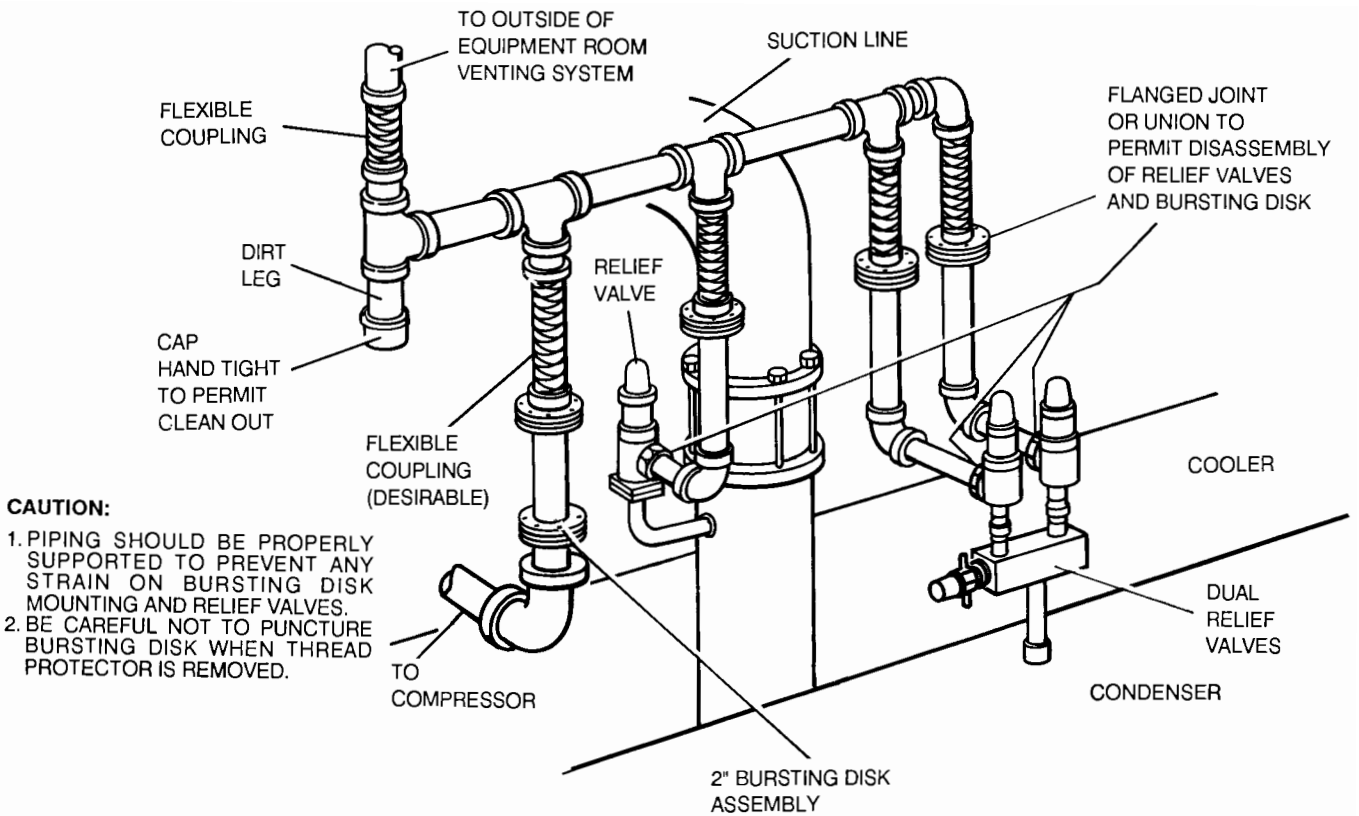

FIG. 9 – LOCATION OF RELIEF VALVES AND 2" BURSTING DISK



CAUTION:

1. PIPING SHOULD BE PROPERLY SUPPORTED TO PREVENT ANY STRAIN ON BURSTING DISK MOUNTING AND RELIEF VALVES.
2. BE CAREFUL NOT TO PUNCTURE BURSTING DISK WHEN THREAD PROTECTOR IS REMOVED.

FIG. 10 – TYPICAL REFRIGERANT VENT PIPING

REFER TO FIG. 9

UNIT PIPING

Compressor lubricant piping, and system external piping are factory installed on all units shipped assembled. On units shipped dismantled, the following piping should be completed under the supervision of the YORK representative: (1) The lubricant piping to oil sump and oil cooler; and system oil return. See piping drawings furnished by the engineering department.

REFRIGERANT TRANSFER UNIT WATER CONNECTIONS (Refer to FIG. 11)

During operation the refrigerant transfer unit requires water to be run through it's condenser. Since the transfer unit will only be used to transfer refrigerant gas from the cooler to the unit condenser shell. For refrigerant storage during a long shutdown period or for servicing the unit it is recommended that the proper fittings be used to attach a garden hose to each 3/4 NPTI connection to run water through it and out to a drain during the transfer unit operation.

CONTROL WIRING

On units shipped disassembled, after installation of the control center, control wiring must be completed between unit components and control center using wiring harness as furnished. Refer to Form 160.65-N1.2 and Forms 160.65-PA2.1 MicroComputer Control Center with electro-mechanical starter and wiring drawings furnished by engineering department.

Field wiring connections for commonly encountered control modifications (by others) if required, are shown on Form 160.65-PA4.1.

NOTE: No deviations in unit wiring from that shown on drawings furnished shall be made without prior approval of the YORK REPRESENTATIVE.

POWER WIRING

CÓDEPAK with Electro-Mechanical Starter (Refer to Field Wiring Diagram Form 160.46-PA3.2).

A 115 volt single phase 60 or 50 Hertz power supply of 20 amperes must be furnished to the control center, from

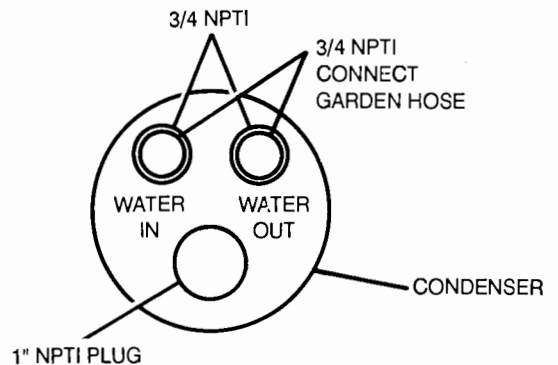

FIG. 11 – REFRIGERANT TRANSFER UNIT CONDENSER CONNECTION SIZES

the control transformer (2 KVA required) included with the compressor motor starter. DO NOT make final power connections to control center until approved by YORK representative.

NOTE: Remote electro-mechanical starters for the CODEPAK must be furnished in accordance with YORK Standard R-1074, Product Drawing Form 160.65-PA5.1 to provide the features necessary for the starter to function properly with the YORK control system.

Oil Pump – 3 Phase Starter and Refrigerant Transfer Unit

Separate wiring and fused disconnect switches should be supplied by the installer. Refer to the Field Wiring Diagram Form 160.65-PA3.2.

Each CODEPAK unit is furnished for a specific electrical power supply as stamped on the Unit Data Plate. The motor connection diagrams are in the motor terminal box.

NOTE: To insure proper motor rotation the starter power input and starter to motor connections must be checked with a phase sequence indicator in the presence of the YORK representative.

IMPORTANT

DO NOT cut wires to final length or make final connections to motor terminals or starter power input terminals until approved by the YORK representative.

YS Motors (Electro-Mechanical Starter)

For the power wiring hook-up for YS CODEPAK Motor Connections. Refer to Wiring Label in Motor Terminal Box for hook-up to suit motor voltage and amperage.

Motor leads are furnished with a crimp type connection having a clearance hole for a 3/8" bolt. Motor terminal lugs are not furnished.

INSULATION

(See Product Drawings FORM 160.65-PA1.1)

Insulation of the type specified for the job, of minimum thickness to prevent sweating of 30°F surfaces (water chiller application), should be furnished (by others) and applied to the cooler shell, end sheets, liquid feed line from the liquid control valve, compressor suction connection, and cooler liquid heads and connections. The liquid head flange insulation must be removable, to allow head removal for tube maintenance. Details of areas to be insulated are given on the Product Drawing.

Units are furnished factory anti-sweat insulated on order at additional cost. This includes all low temperature surfaces except the two (2) cooler liquid heads.

IMPORTANT

DO NOT field insulate until the unit has been leak tested under the supervision of the YORK representative.

INSTALLATION CHECK-REQUEST FOR START-UP SERVICE

After the unit is installed, piped and wired as described in this Instruction, but before any attempt is made to start the unit, the YORK Service Office should be advised so that the start-up service, included in the contract price, can be scheduled. Notification to the YORK office should be by means of Installation Check List and Request, Form 160.65-CL1, in triplicate. (See Fig. 12, page 14.)

The services of a YORK representative will be furnished to check the installation and supervise the initial start-up and operation on all CODEPAKS. (In accordance with the contract price.)

MODEL YS

YORK

CodePak

INSTALLATION CHECK LIST AND REQUEST FOR AUTHORIZED START-UP ENGINEER

*TO: _____ **JOB NAME:** _____
 _____ **LOCATION:** _____
 _____ **CUSTOMER ORDER NO.** _____
YORK TEL. NO. _____ **YORK ORDER NO.** _____ **YORK CONTRACT NO.** _____

CODEPAK _____
MODEL NO. _____ **SERIAL NO.** _____

The work (as checked below) is in process and will be completed by _____ / _____ / _____
 Month Day Year

The following work must be completed in accordance with installation instructions

A. YORK CODEPAK

- 1. Unit assembled (if shipped dismantled) and refrigerant piping installed under YORK Supervision
- 2. Vibration isolator mounts so the unit is level, and isolators equally deflected

B. WATER PIPING

- 1. Condenser water piping installed between condenser, pumps and cooling tower
- 2. Chilled water piping installed between cooler, pumps and cooling coils
- 3. Make-up and fill lines installed to cooling tower and chilled water system
- 4. All water piping checked for strain—Piping should not spring when connections are broken at unit
- 5. Water piping leak tested and flushed, and water strainers cleaned after flushing. Piping systems filled with water and trapped air vented
- 6. Chilled and condenser water flow available to meet unit design requirements

C. REFRIGERANT RELIEF PIPING (when required)

- 1. Refrigerant relief piping (with flexible connection) installed from unit to outside equipment room venting system

D. ELECTRICAL WIRING

- 1. Electro-mechanical starter
 - a. Main and control power supply available
 - b. Compressor motor starter furnished in accordance with YORK Standard R-1074 — Form 160.65-PA5.1
 - c. Wiring completed from main power supply to starter—but not cut to length or connected to starter
 - d. Wiring completed from starter to compressor motor—but not cut to length or connected to motor
 - e. 115 volt service completed to Control Center—but not connected

- f. 3-phase wiring completed to oil pump starter and Refrigerant Transfer Unit but not connected
- 2. Control center
 - a. Jumper wire not installed between terminal 18 and 43 located on the control center terminal strip
 - b. External control wiring completed from the control center to chilled water flow switches on interlocks in accordance with the YORK Wiring Diagram
 - c. Power available and wiring completed to the following starters and motors, and rotation of each checked
 - NOTE—Do not check compressor motor rotation
 - (1.) Chilled water pump(s)
 - (2.) Condenser water pump(s)
 - (3.) Cooling tower fan
 - d. Meg ohm meter available for checking motor windings

E. TESTING, EVACUATION AND CHARGING (Under York Supervision if Unit Shipped Less Refrigerant or Dismantled).

- 1. R-22 available for testing
- 2. Dry Nitrogen available for testing
- 3. A high vacuum pump available for evacuation and dehydration of system
- 4. Refrigerant-22 (Supplied by YORK available for charging)
- 5. Unit (ready to be) (has been) pressure tested, evacuated, dehydrated and charged

F. CONDITIONS

- 1. YORK oil for compressor on job
- 2. Cooling load available for testing and operating unit
- 3. Personnel available for final wiring connections
- 4. Personnel available for start-up and testing
- 5. Owners operating personnel available for instruction

Names: _____

With reference to the terms of the above contract, we are requesting the presence of your Authorized Representative at the job site on _____ / _____ / _____ to start the system and instruct operating personnel HAVE HIM CONTACT _____ Month
Day Year Names

We understand that the services of the YORK Authorized Representative will be furnished in accordance with the contract for a period of not more than _____ consecutive normal working hours, and we agree that a charge of _____ per diem plus travel expenses will be paid to YORK if services are required for longer than _____ consecutive normal hours or if repeated calls are required.

Signed: _____
 Title: _____

FIG. 12 — INSTALLATION CHECK LIST AND REQUEST FORM FOR AUTHORIZED START-UP ENGINEERING



P.O. Box 1592, York, Pennsylvania USA 17405-1592
Copyright © by York International Corporation 1994
Form 160.05-N1 (290)
Supersedes: 160.05-N1 (1189)

Subject to change without notice. Printed in USA
ALL RIGHTS RESERVED
RPC 3M 894 .80
CODES: SK & RSC