

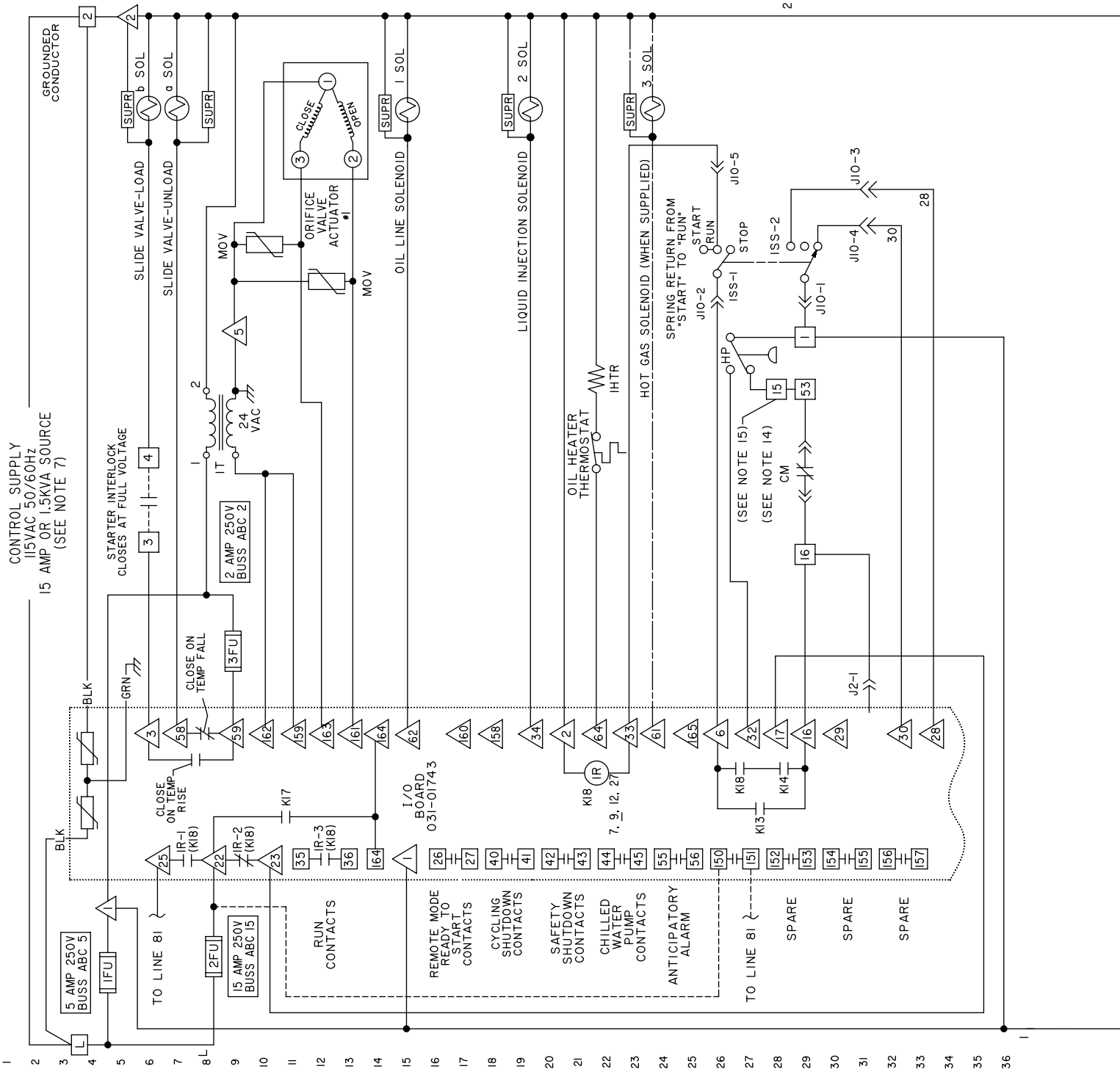

# ELEMENTARY DIAGRAM

035-17847



035-17847D  
SHT 1 OF 6  
REV. A

37  
38  
39  
40  
41  
42  
43  
44  
45  
46  
47  
48  
49  
50  
51  
52  
53  
54  
55  
56  
57  
58  
59  
60  
61  
62  
63  
64  
65  
66  
67  
68  
69  
70  
71  
72

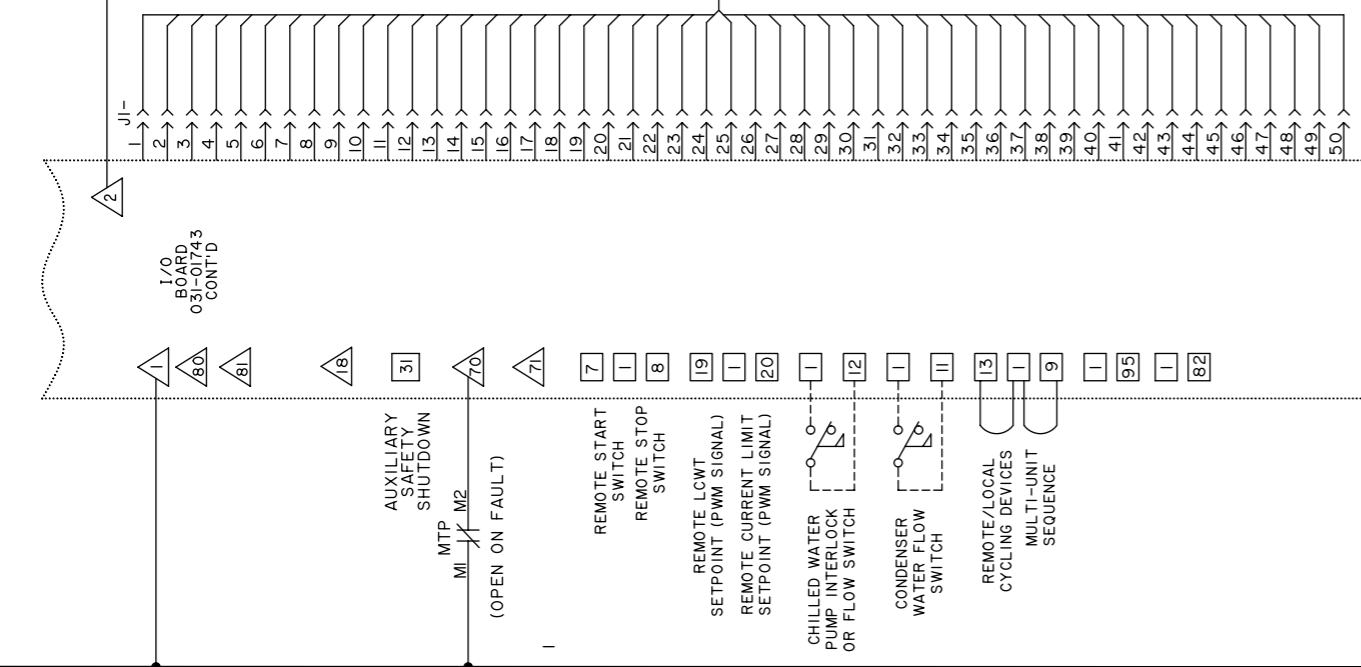

72  
73  
74  
75  
76  
77  
78  
79  
80  
81  
82  
83  
84  
85  
86  
87  
88  
89  
90  
91  
92  
93  
94  
95  
96  
97  
98  
99  
100  
101  
102  
103  
104  
105

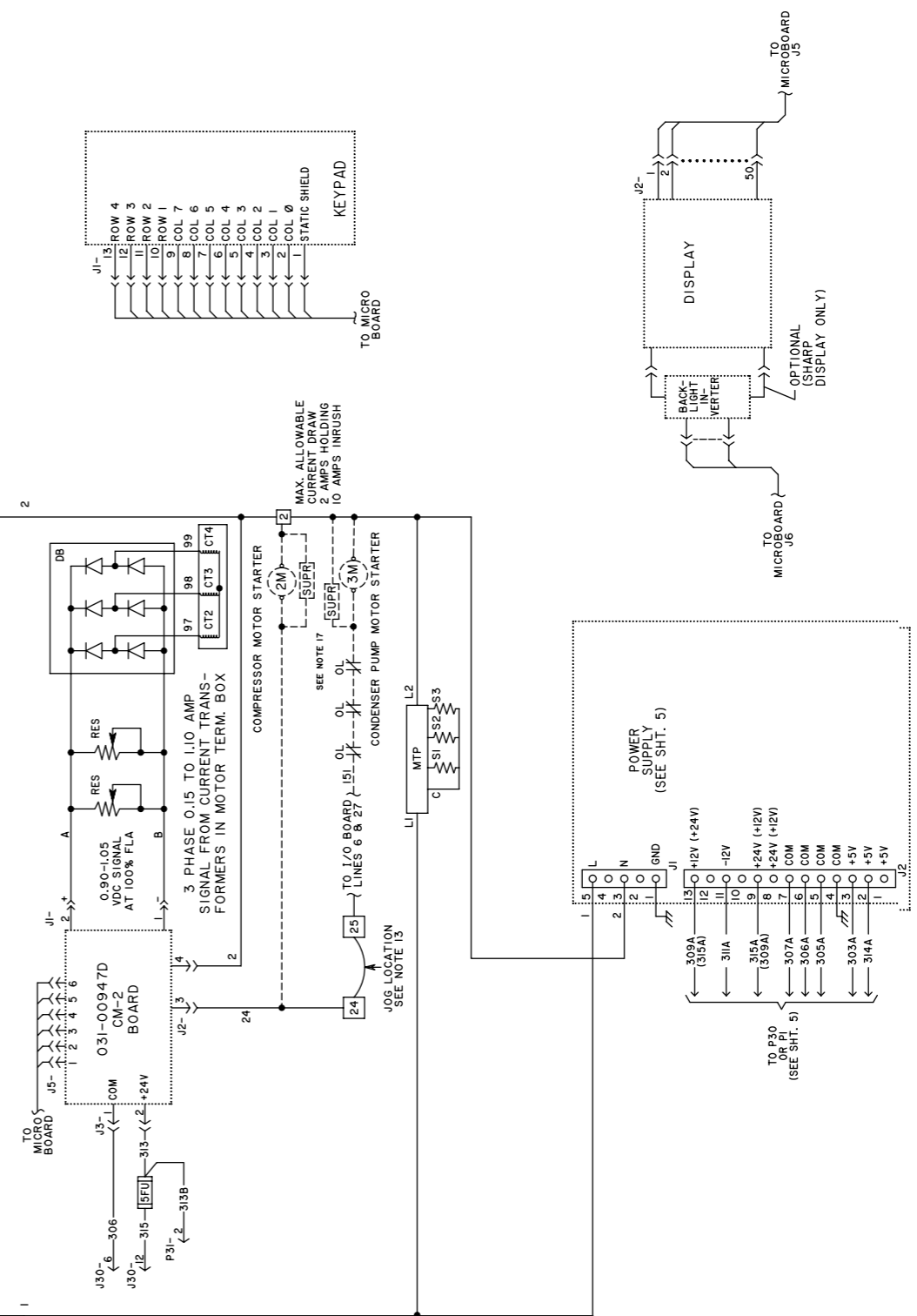

# ELEMENTARY DIAGRAM (Cont'd)

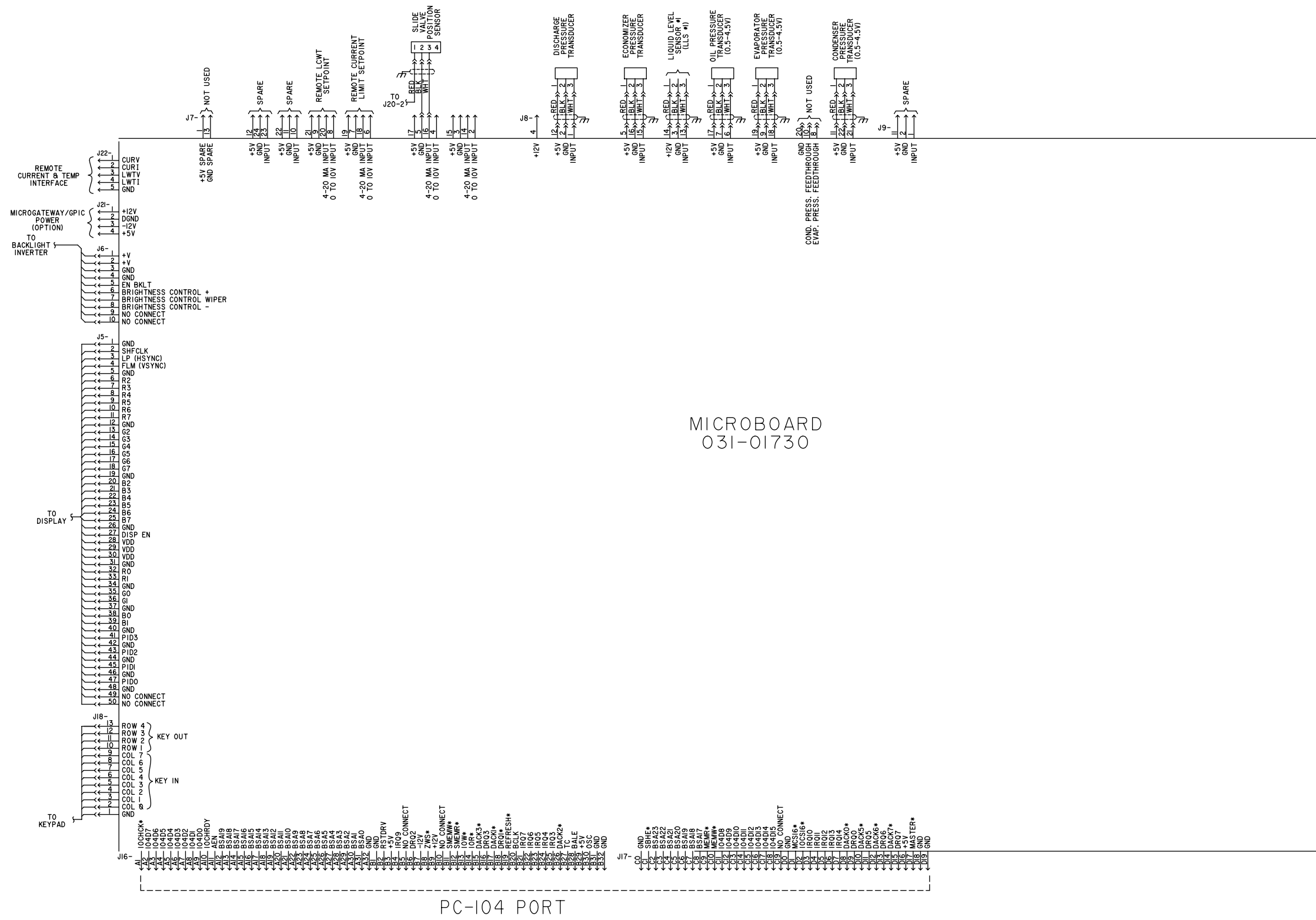

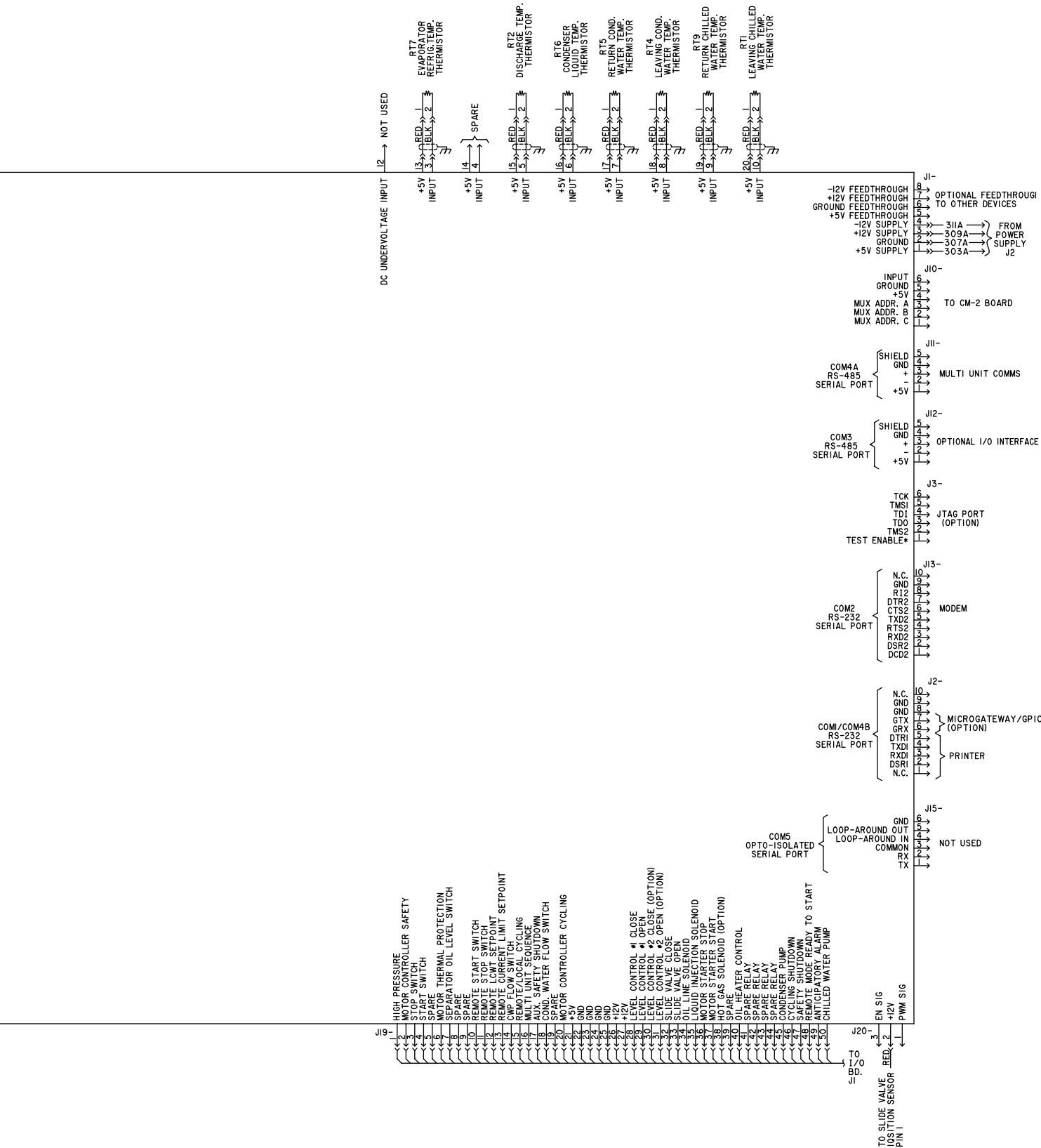



# CONNECTION DIAGRAM (Cont'd)

## MOTOR TERMINAL BOX

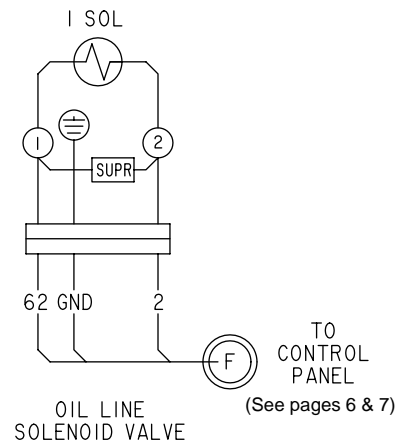
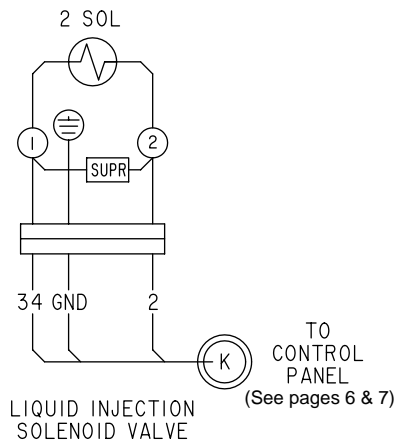
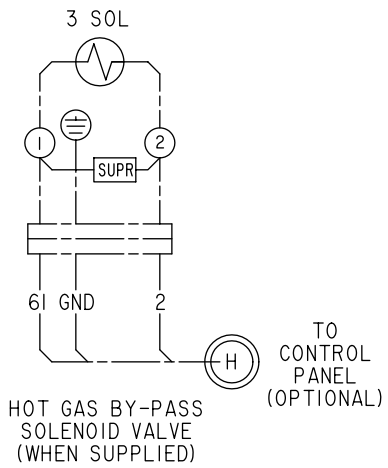
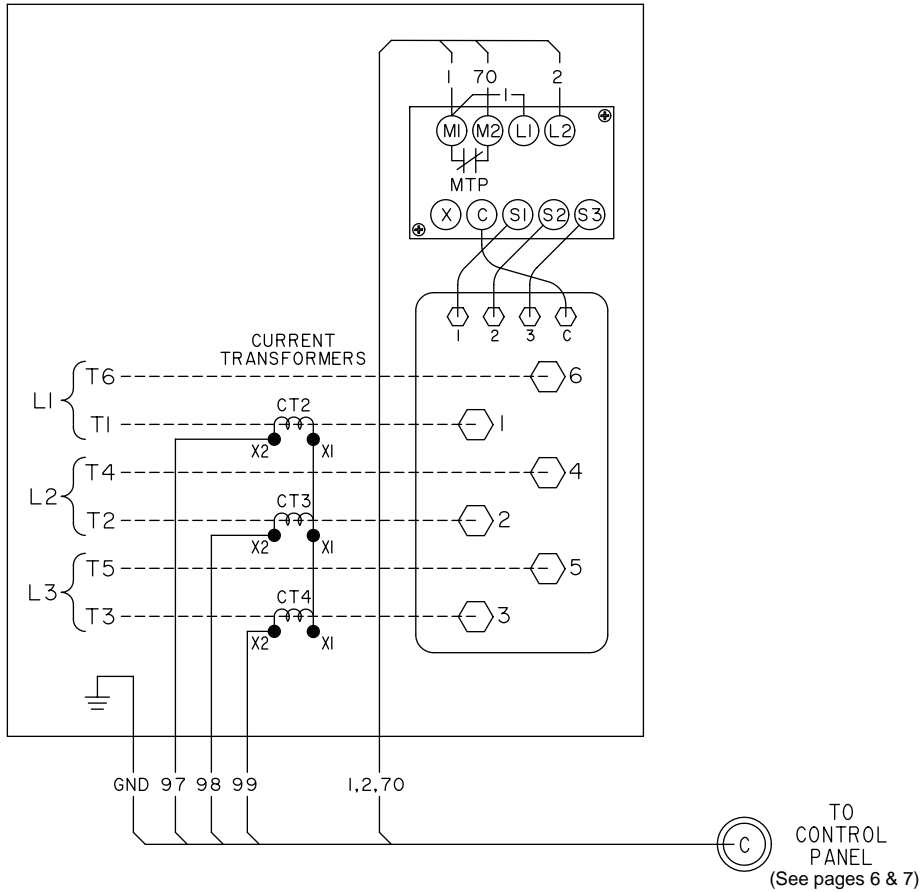

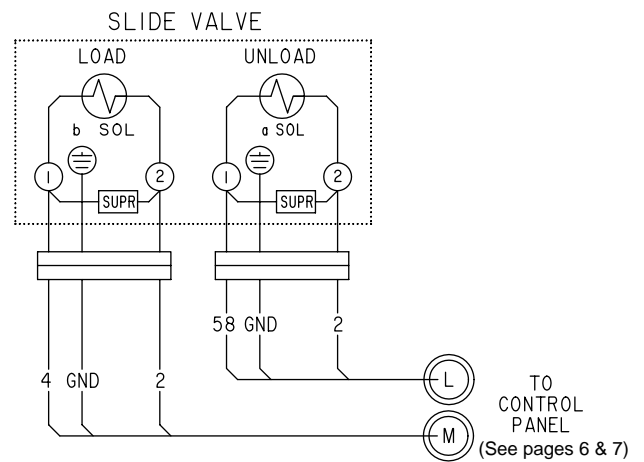
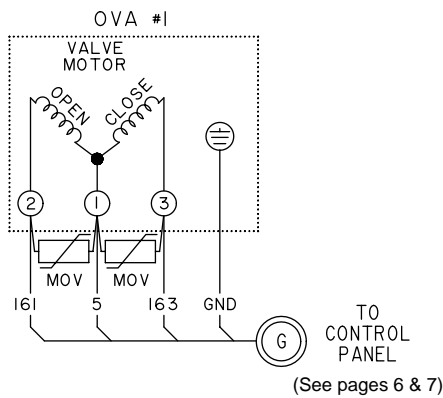
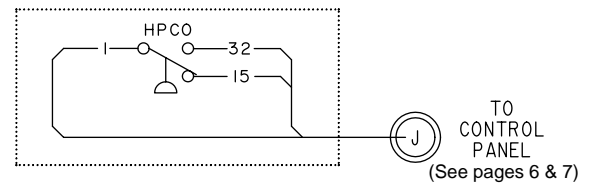
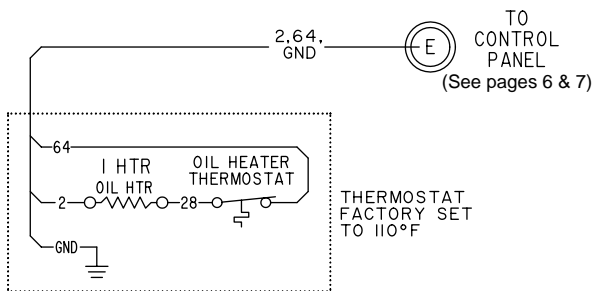
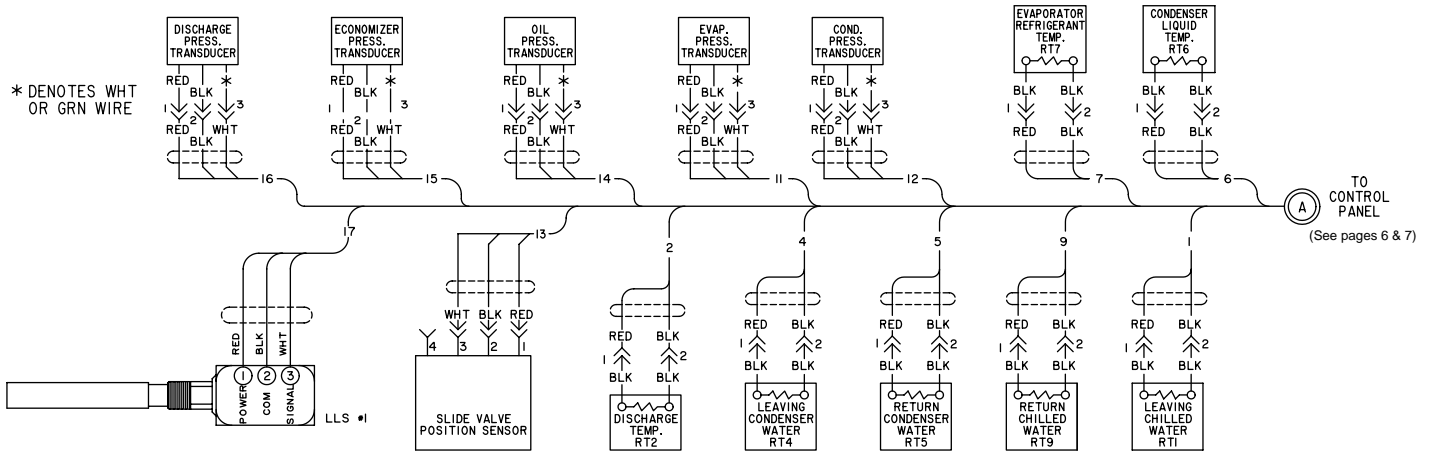

LD06883

# CONNECTION DIAGRAM (CONT'D)

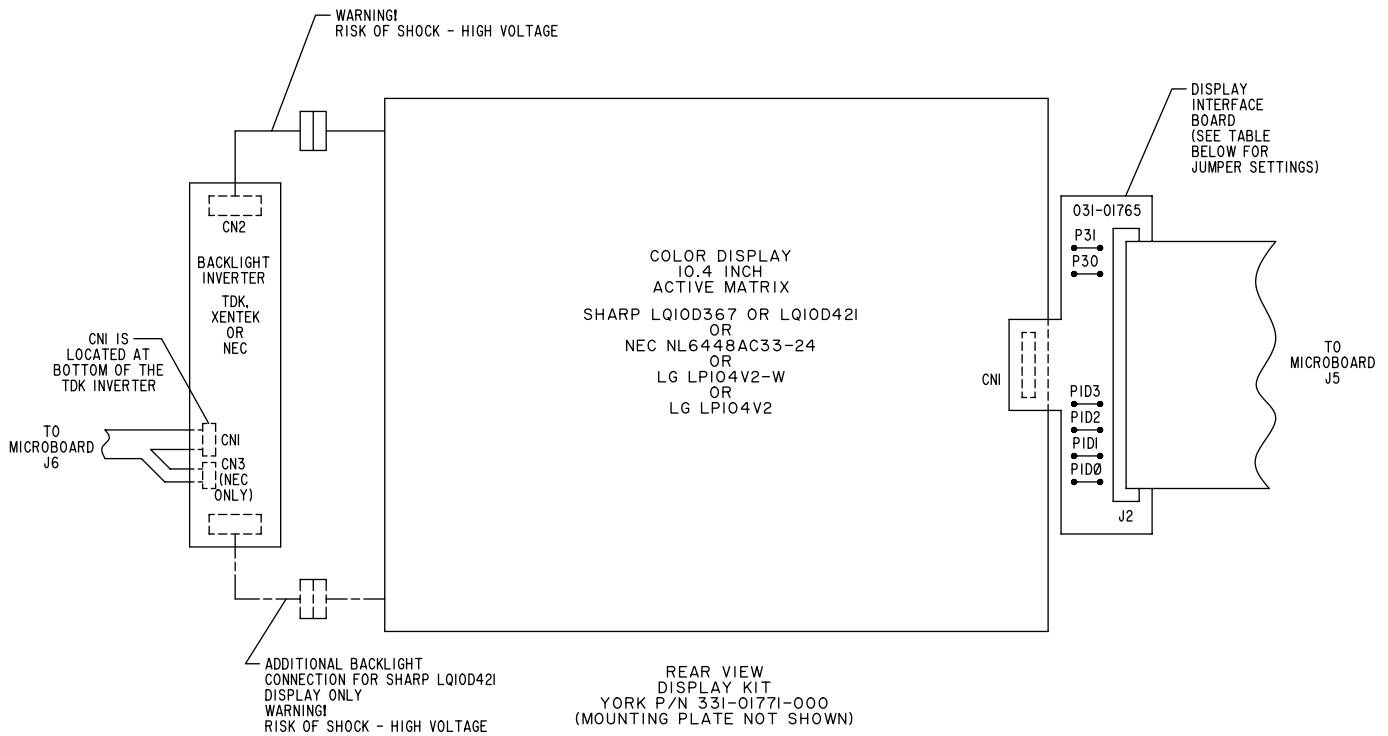

## INSIDE VIEW OF FRONT DOOR

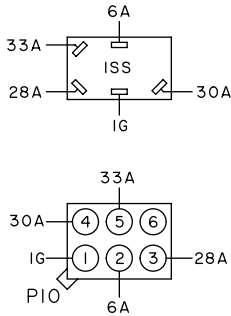

DISPLAY INTERFACE BOARD JUMPER SETTINGS

DISPLAY	P30	P31	PID3	PID2	PID1	PID0
SHARP LQ10D367	IN	IN	OUT	OUT	IN	OUT
SHARP LQ10D421	IN	IN	OUT	OUT	IN	OUT
NEC OR LG	OUT	OUT	OUT	OUT	OUT	IN

LD06872

PRESSURE-TEMPERATURE CHART							
APPLICATION		DEVICE	UNITS	OPERATING POINT			
CHILLED WATER	BRINE			ON RISE		ON FALL	
✓	✓	HDT	DEG.F/DEG.C	175.1/79.5		175/79.4	
✓	✓	LOP**	SEE NOTE 10				
✓	✓	HP	PSIG/ kPa	CUT-OUT 190/1310	PROGRAMMABLE PER OPERATOR'S MANUAL FORM *		CUT-IN 150/1034
✓	✓	HDP	PSIA/ kPa		UNLOAD SLIDE VALVE 200.0/1379	ALLOW SLIDE VALVE LOADING 190.0/1310	
✓		LEP (R-134 a)	PSIG/ kPa	CUT-IN 25.1/173	ALLOW SLIDE VALVE LOADING 28.0/193	INHIBIT SLIDE VALVE LOADING 27.0/186	CUT-OUT 25.0/172
✓	✓	HOP**	PSID/ kPa	180/1241		179/1234	
✓	✓	FDTs	DEG.F/DEG.C	30.0/-1.10		29.9/-1.20	
✓		LWT	DEG.F/DEG.C	PROGRAMMABLE PER OPERATOR'S MANUAL FORM			
	✓	LWT	DEG.F/DEG.C				
✓	✓	CLOGGED OIL FILTER***	PSID/ kPa	25.0/172		24.9/172	
✓	✓	DIRTY OIL FILTER WARNING***	PSID/ kPa	20.0/138		19.9/137	

\* - FUNCTION PROVIDED BY CONDENSER TRANSDUCER

\*\* - DIFFERENTIAL PRESSURE = OIL PRESS. - EVAP. PRESS. - OFFSET PRESS.

\*\*\* - DIFFERENTIAL PRESSURE = DISCHARGE PRESS. - OIL PRESS.

LD06869

