



**WATER-COOLED LIQUID CHILLERS  
HERMETIC SCROLL 50 HZ**

**RENEWAL PARTS**

New Release

Form: 201.24-RP2 (303)

**MODELS YCWS0313, 0373, 0423, 0503, 0563, 0613  
AND YCWS0663SC**



264 - 587 kW

R-22

STYLE B

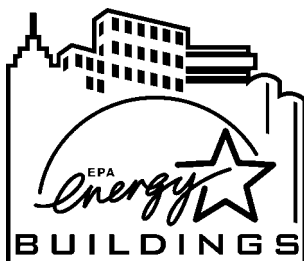

ALLY



380-415/3/50  
MODELS ONLY

## TABLE OF CONTENTS

	PAGE
UNIT NOMENCLATURE NAMEPLATE ENGINEERING DATA .....	3
<b>EVAPORATOR</b>	
EVAPORATOR COMPONENTS .....	4
<b>CONDENSER</b>	
CONDENSER COIL COMPONENTS .....	6
<b>PIPING</b>	
REFRIGERANT AND OIL PIPING COMPONENTS .....	8
<b>COMPRESSOR</b>	
COMPRESSOR .....	12
<b>CONTROL AND POWER PANELS</b>	
CONTROL PANEL, OPTION PANEL AND POWER PANEL .....	24
WIRE HARNESS CONNECTORS - FIELD REPLACEMENT PART NUMBERS .....	35
TRANSDUCERS, PRESSURE CUTOUTS AND TEMP SENSORS .....	36
<b>CHILLER OPTIONS</b>	
YCWS CHIILER OPTIONS - KITS .....	38
OPTI-VIEW REMOTE CONTROL PANEL .....	40
REMOTE CURRENT/TEMPERATURE RESET PARTS BREAKDOWN .....	41
RECOMMENDED SPARE PARTS .....	42

# WARNING

## HIGH VOLTAGE

**Is used in the operation of this equipment.**

## DEATH OR SERIOUS INJURY

**may result if personnel fail to observe safety precautions.**

Work on electronic equipment should not be undertaken unless the individual(s) have been trained in the proper maintenance of equipment and is (are) familiar with its potential hazards.

Shut off power supply to the equipment before beginning work and follow lockout procedures. When working inside equipment with power off, take care to discharge every capacitor likely to hold dangerous potential.

Be careful not to contact high voltage connections when installing or operating this equipment.

## LOW VOLTAGE

DO NOT be misled by the term "low voltage." Voltages as low as 50 volts may cause death.

# UNIT NOMENCLATURE NAMEPLATE ENGINEERING DATA

## BASIC PART NUMBER

# YCWS0423SC50YBA

<b>1</b>	<b>2</b>	<b>3</b>	<b>4</b>	<b>5</b>	<b>6</b>	<b>7</b>	<b>8</b>	<b>9</b>	<b>10</b>	<b>11</b>	<b>12</b>	<b>13</b>	<b>14</b>	<b>15</b>
BASE PRODUCT TYPE				NOMINAL CAPACITY				UNIT DESIGNATOR	REFRIGERANT	VOLTAGE/STARTER			DESIGN/DEVELOPMENT LEVEL	
Y	C	W	S	#	#	#	#	S	C	5	0	Y	A	A
: YORK : Chiller : Water Cooled S : Screw				Tons 0313 0373 0423 0503 0573 0613 0663				Standard Unit	:R-22 :R-407C	:360-415/3/50 :Wye Delta			:Design A (60Hz) :Design B (50Hz) :Engineering Change or PIN Level	

## PART NUMBER – LETTER CODES

<p><b>16 17 18 19</b> <b>POWER FIELD</b></p> <p>X X : MP TB M D : MP NF DS M B : MP w/Ind. Sys. Brkr. &amp; L.Ext. Hdls S S : SP TB w/Ind. Sys. Disc. Sw. S B : SP TB w/Ind. Sys. Brkr. &amp; L.Ext. Hdls D B : SP NF DS w/Ind. Sys. Brkr. &amp; L.Ext. Hdls F B : SP NF DS w/Ind. Fuses 6 5 : SP High Fault Current 65Ka</p> <p><b>MP = Multiple Point Supply</b> <b>SP = Single Point Supply</b> <b>NF = Non-Fused</b> <b>DS = Disconnect Switch</b> <b>TB = Terminal Block</b> <b>Ser. = Service</b> <b>Ind. Sys. Brkr. &amp; L. Ext. Hdls = Individual System Breaker &amp; Lockable External Handle</b></p>	<p><b>20 21 22 23 24 25 26 27 28</b> <b>CONTROLS FIELD</b></p> <p>T : BAS/EMS Temp. Reset / Offset C : BAS/EMS Current Reset / Offset B : Both Low / High Ambient (factory) S : Spanish LCD &amp; Keypad Display F : French LCD &amp; Keypad Display G : German LCD &amp; Keypad Display L : N. American Safety Code (cU.L./cETL) N : No Listing (typically 50 HZ non-CE, non-U.L.) O : Opti-View Remote Panel S : Sequence Control &amp; Automatic Lead Transfer</p>	<p><b>29 30 31 32 33 34 35 36 37</b> <b>COMPRESSOR / PIPING FIELD</b></p> <p># # : Leaving Supply Temp T S : Thermal Storage C : Chicago Relief Code</p>
--	---	--

<p><b>38 39 40 41 42 43 44</b> <b>EVAP. FIELD</b></p> <p>W : Weld Flange Kit V : Victualic Flange Kit S : Flow Switch D : Diff. Pressure Switch A : ASME Pressure Vessel &amp; Associated Codes</p>	<p><b>45 46 47</b> <b>CONDENSER FIELD</b></p> <p>X : Aluminum</p>	<p><b>48 49 50 51 52 53 54</b> <b>CABINET FIELD</b></p> <p>P : Hand Held Printer X : Form 1 Shipment S : Final Overspray Paint 1 : 1" Deflection S : Seismic N : Neoprene Pads</p>
<p><b>55</b> <b>EXTENDED FIELD</b></p> <p>X : 1st Year Parts Only B : 1st Year Parts &amp; Labor C : 2nd Year Parts Only D : 2nd Year Parts &amp; Labor E : 5 Year Compressor Parts Only F : 5 Year Compressor Parts &amp; Labor Only G : 5 Year Units Parts Only</p>		
<p><b>NOTES:</b></p> <p>1. Q :DENOTES SPECIAL / S.Q. 2. # :DENOTES STANDARD 3. X :w/in OPTIONS FIELD, DENOTES NO OPTION SELECTED</p>		

# EVAPORATOR COMPONENTS

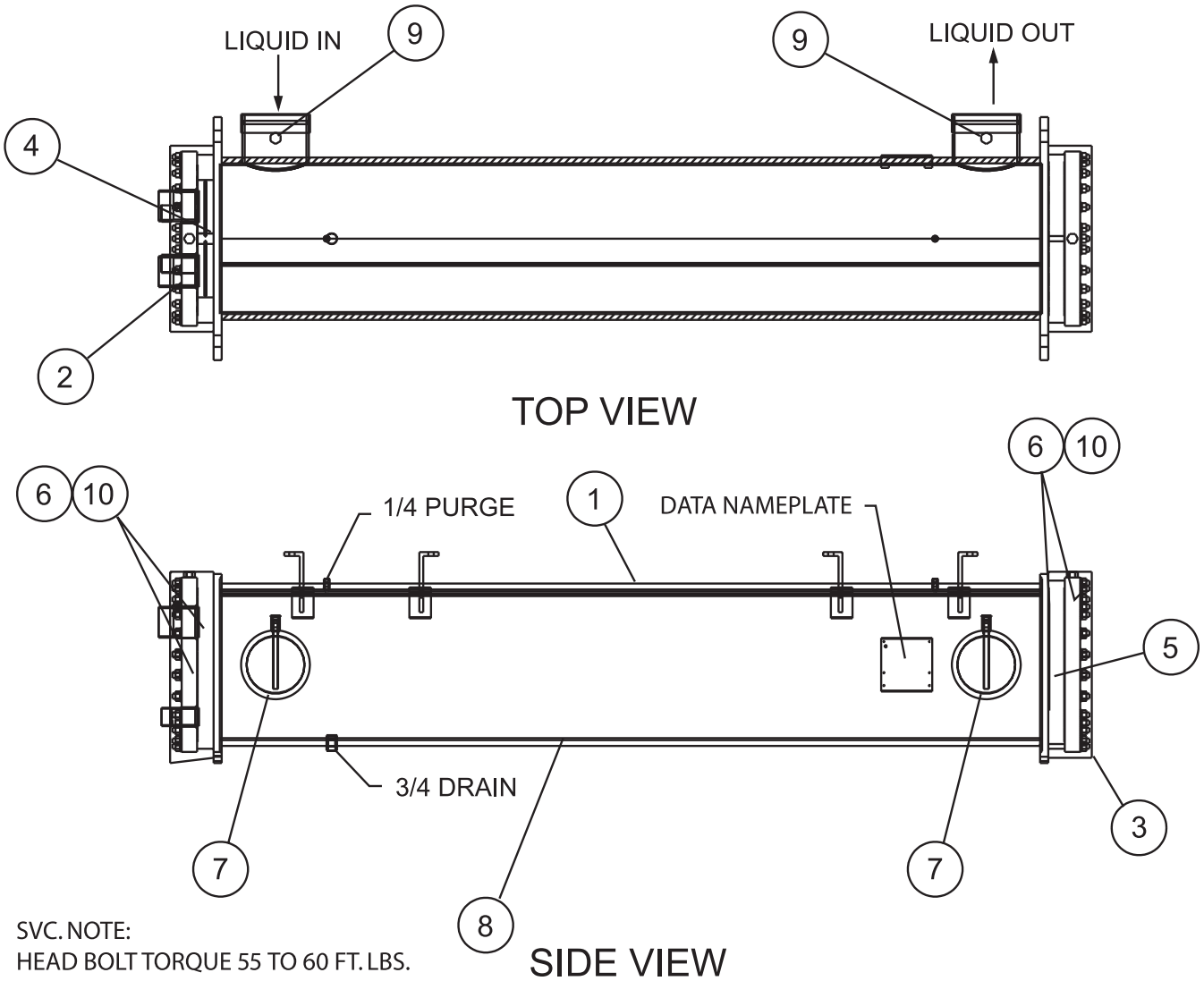

44044-000

FIG. 1 –EVAPORATOR COMPONENTS - 50 HERTZ (REF. TABLE 1, PAGE 5)

## EVAPORATOR COMPONENTS (CONT'D)

**TABLE 1 – EVAPORATOR COMPONENTS - 50 HERTZ (SEE FIG. 1, PAGE 4)**

ITEM NUMBER	QTY. PER UNIT	DESCRIPTION	DWP	UNIT MODEL YCWS0313	UNIT MODEL YCWS0373 AND 0423
1	1	Evaporator, less Insulation (Items 2 thru 6)	ALL	375-41731-000	375-41729-000
2	1	Head, Conn. End	ALL	375-44037-000	375-41741-000
3	1	Head, Back End	ALL	375-44035-000	375-41739-000
4	1	Baffle, Pass, Conn. End	ALL	375-44041-000	375-41735-000
5	1	Baffle, Pass, Back End	ALL	075-44039-000	075-41737-000
6	4	Gasket, Pass Baffle and Head	ALL	075-40928-000	075-41738-000
7	1	Well, Thermo	ALL	026-32328-000	026-33627-000
8	2	Insulation (3/4" x 49" x 65")	ALL	010-05997-000	010-04198-000
9	2	Sensor, Water Temp.	ALL	025-29964-000	025-29964-000
10	1	Adhesive (Use with #6)	ALL	013-03311-000	013-03311-000

**TABLE 1 (CONT'D) – EVAPORATOR COMPONENTS - 50 HERTZ (SEE FIG. 1, PAGE 4)**

ITEM NUMBER	QTY. PER UNIT	DESCRIPTION	DWP	UNIT MODEL YCWS0503 AND 0563	UNIT MODEL YCWS0613 AND 0663
1	1	Evaporator, less Insulation (Items 2 thru 6)	ALL	375-41730-000	375-41728-000
2	1	Head, Conn. End	ALL	375-44013-000	375-44027-000
3	1	Head, Back End	ALL	375-44011-000	375-44024-000
4	1	Baffle, Pass, Conn. End	ALL	375-44008-000	375-44021-000
5	1	Baffle, Pass, Back End	ALL	075-44009-000	075-44020-000
6	4	Gasket, Pass Baffle and Head	ALL	075-44010-000	075-44019-000
7	1	Well, Thermo	ALL	026-33627-000	026-33627-000
8	2	Insulation (3/4" x 49" x 65")	ALL	010-04198-000	010-05997-000
9	2	Sensor, Water Temp.	ALL	025-29964-000	025-29964-000
10	1	Adhesive (Use with #6)	ALL	013-03311-000	013-03311-000

**Service Notes:**

1. Head Bolt Torque Specifications - 50 to 60 ft. lbs.
2. DWP - 150 Waterside  
(PSI) - 300 Refrigerant

## CONDENSER COMPONENTS

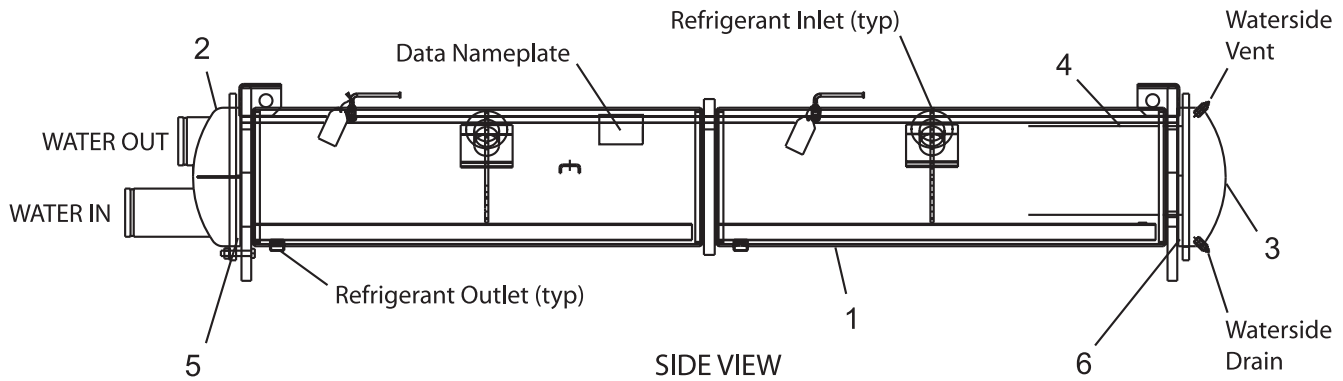

44047-0b

FIG. 2 – CONDENSER COMPONENTS (REF. TABLE 2)

TABLE 2 – CONDENSER COMPONENTS (SEE FIG. 2)

ITEM NUMBER	QTY. PER UNIT	DESCRIPTION	DWP	UNIT MODEL YCWS0313 THRU 0373	UNIT MODEL YCWS0423 AND 0503	UNIT MODEL YCWS0613 AND 0663
1	1	CONDENSER (INCLUDES ITEMS 2 THRU 6)	ALL	375-46964-000 1836 LBS.	375-46965-000 3201 LBS.	375-46966-000 3201 LBS.
2	1	HEAD, CONDENSER - FRONT	ALL	375-35862-000	375-35869-000	375-35808-000
3	1	HEAD, CONDENSER - REAR	ALL	366-92136-001	366-92136-001	366-92590-001
4	-	TUBE, COPPER (# OF TUBES PER CONDENSER)	ALL	007-09600-000 134	007-09600-000 202	007-09600-000 216
5	1	GASKET, FRONT HEAD	ALL	067-77469-000	067-77469-000	066-92951-000
6	1	GASKET, REAR HEAD	ALL	067-77469-000	067-77469-000	066-92951-000

### Service Notes:

1. 3/4" Copper Tubes x 0.035" Wall.
2. Trim center rib off rear head gasket, item 6.
3. Torque Heads 75 - 85 FT. LBS.
4. Use adhesive 013-03311-000 for gasket installation.

This page intentionally left blank

# REFRIGERANT AND OIL PIPING COMPONENTS CHILLER MODEL YCWS

Piping

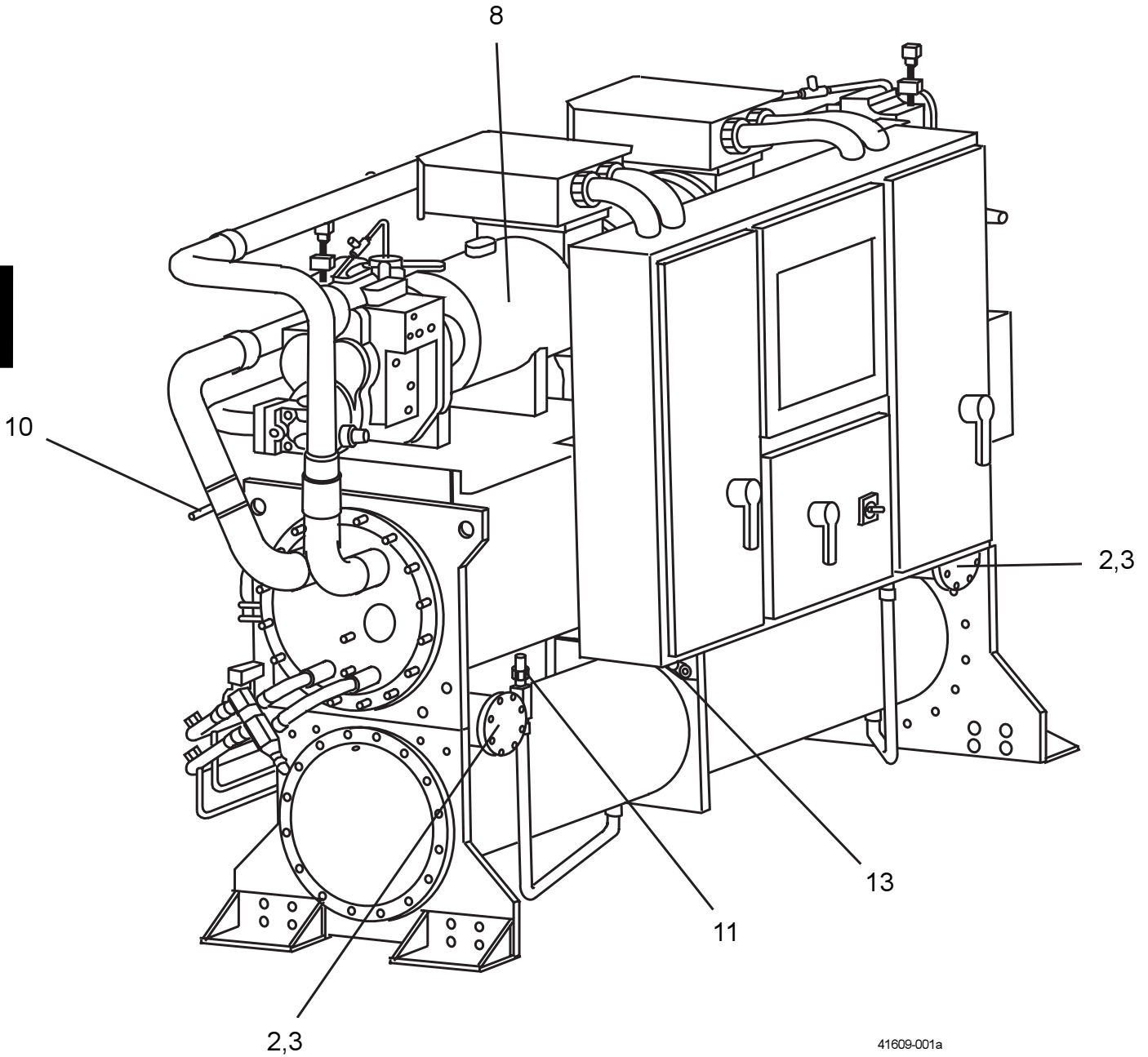

41609-001a

FIG. 3 – REFRIGERANT AND OIL PIPING COMPONENTS (REF. TABLE 3, PAGES 10 AND 11)

## REFRIGERANT AND OIL PIPING COMPONENTS (CONT'D) CHILLER MODEL YCWS

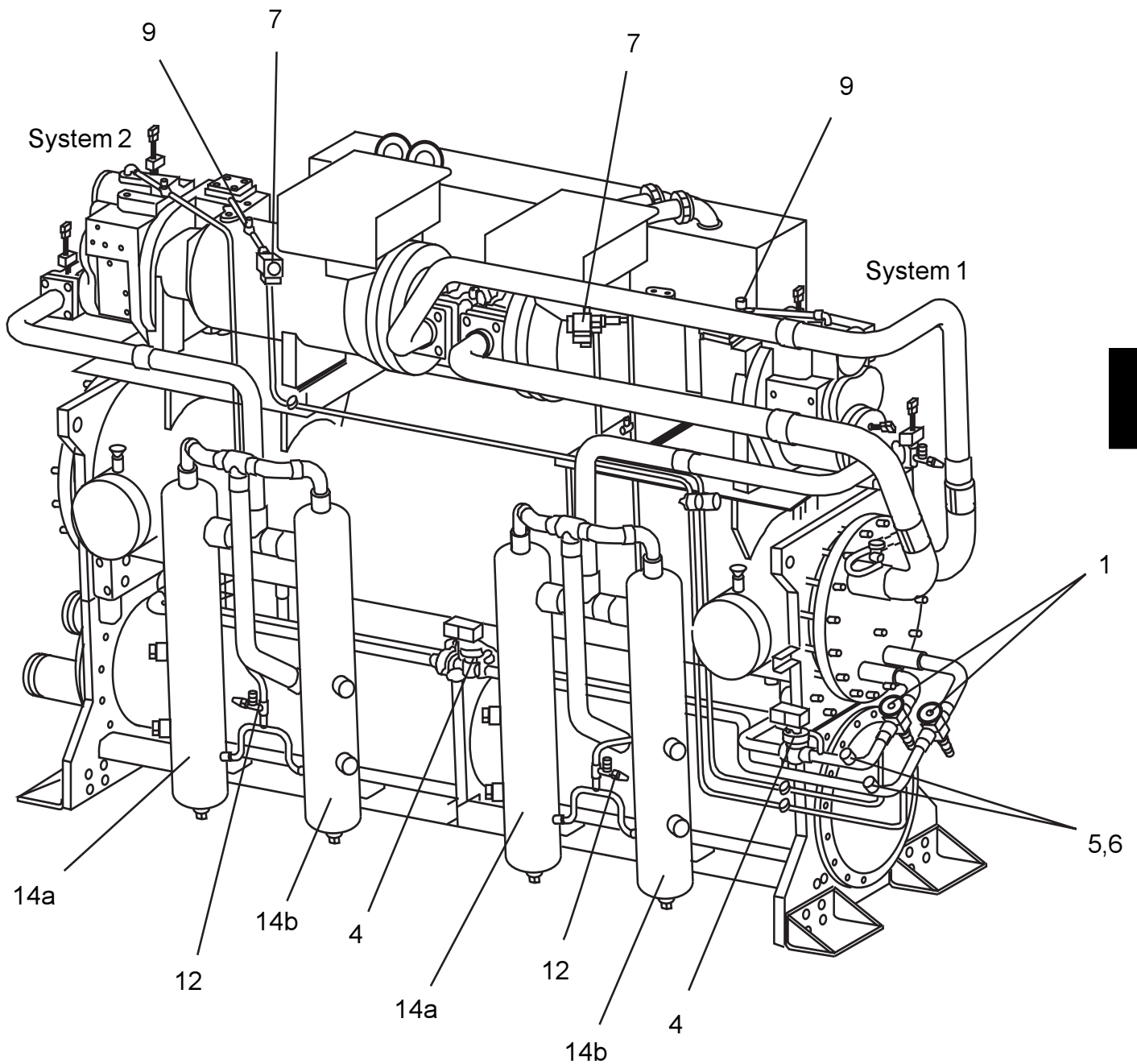

**FIG. 4 – REFRIGERANT AND OIL PIPING COMPONENTS - DUAL OIL SEPARATOR PER SYSTEM UNIT SHOWN (REF. TABLE 3, PAGES 10 AND 11)**

## REFRIGERANT AND OIL PIPING COMPONENTS (CONT'D)

### CHILLER MODEL YCWS - STYLE SC

**TABLE 3 – REFRIGERANT PIPING AND OIL PIPING COMPONENTS (SEE FIGS. 3 AND 4, PAGES 8 AND 9)**

ITEM NO.	SYSTEM	DESCRIPTION	YCWS0313	YCWS0373	YCWS0423	YCWS0503
1 <sup>s</sup>	1	Valve, Thermal Expansion	025-32904-000	025-32904-000	025-32904-000	025-32904-000
	2		025-32904-000	025-32904-000	025-32904-000	025-35757-000
2	Both	Shell, Dehydrator	026-21055-000	026-21055-000	026-21055-000	026-21055-000
3 <sup>s</sup>	Both	Filter Cartridge	026-18328-000	026-18328-000	026-18328-000	026-18328-000
4 <sup>s</sup>	1	Valve, Solenoid, Liq. Line	025-33705-000	025-33705-000	025-00240-000	025-33704-000
	2		025-33705-000	025-00240-000	025-00240-000	025-00240-000
5	1	Moisture Indicator, Body	026-37544-000	026-37544-000	026-37544-000	026-37544-000
	2		026-37544-000	026-37544-000	026-37544-000	026-37544-000
6	Both	Moisture Indicator, Sight Glass, Cap Assembly	026-37548-000	026-37548-000	026-37548-000	026-37548-000
7	1	Valve, Oil Solenoid	025-00245-000	022-00245-000	022-00245-000	022-00245-000
	2		025-00245-000	022-00245-000	022-00245-000	022-00245-000
8	Both	Compressor	See Pages 14 for Compressor Part Numbers			
9	Both	Valve, 1/2" Ball	022-09172-000	022-09172-000	022-09172-000	022-09172-000
10	Both	Valve, Relief (300 psi)	022-03056-000	022-03056-000	022-03056-000	022-03056-000
11	Both	Valve, Liquid Line Stop	022-10022-000	022-10022-000	022-10022-000	022-09778-000
			022-10022-000	022-10022-000	022-10022-000	022-10022-000
12	Both	Valve, Oil Charging	022-09754-000	022-09754-000	022-09754-000	022-09754-000
13	Both	Valve, Relief (330 psi)	022-08870-000	022-08870-000	022-08870-000	022-08870-000
14	Both	Oil Separator, Single	075-44765-000	075-44765-000	075-44765-000	075-44765-000
14a	Both	Oil Separator (Left)	075-02711-000	075-02711-000	075-02711-000	075-02711-000
14b	Both	Oil Separator (Right)	075-02712-000	075-02712-000	075-02712-000	075-02712-000

<sup>s</sup> Recommended Spare Part

## REFRIGERANT AND OIL PIPING COMPONENTS (CONT'D) CHILLER MODEL YCWS - STYLE SC

**TABLE 3 (CONT'D) – REFRIGERANT PIPING AND OIL PIPING COMPONENTS (SEE FIGS. 3 AND 4, PAGES 8 AND 9)**

ITEM NO.	SYSTEM	DESCRIPTION	YCWS0563	YCWS0613	YCWS0663
1 <sup>s</sup>	1	Valve, Thermal Expansion	025-35757-000	025-35757-000	025-33709-000
	2		025-35757-000	025-33709-000	025-33709-000
2	Both	Shell, Dehydrator	026-21055-000	026-21055-000	026-16960-000
			026-21055-000	026-16960-000	026-16960-000
3 <sup>s</sup>	Both	Filter Cartridge	026-18328-000	026-18328-000	026-18328-000
4 <sup>s</sup>	1	Valve, Solenoid, Liq. Line	025-33704-000	025-33704-000	025-33281-000
	2		025-33704-000	025-33281-000	025-33281-000
5	1	Moisture Indicator, Body	026-37545-000	026-37545-000	026-37546-000
	2		026-37545-000	026-37546-000	026-37546-000
6	Both	Moisture Indicator, Sight Glass, Cap Assembly	026-37548-000	026-37548-000	026-37548-000
7	1	Valve, Oil Solenoid	022-00245-000	022-00245-000	022-00245-000
	2		022-00245-000	022-00245-000	022-00245-000
8	Both	Compressor	See Pages 14 for Comp. Part Numbers		
9	Both	Valve, 1/2" Ball	022-09172-000	022-09172-000	022-09172-000
10	Both	Valve, Relief (300 psi)	022-03056-000	022-03056-000	022-03056-000
11	Both	Valve, Liquid Line Stop	022-09778-000	022-09778-000	022-09779-000
			022-09778-000	022-09779-000	022-09779-000
12	Both	Valve, Oil Charging	022-09754-000	022-09754-000	022-09754-000
13	Both	Valve, Relief (330 psi)	022-08870-000	022-08870-000	022-08870-000
14	Both	Oil Separator (Single)	075-44765-000	075-44765-000	075-44765-000
14a	Both	Oil Separator (Left)	075-02711-000	075-02711-000	075-02711-000
14b	Both	Oil Separator (Right)	075-02712-000	075-02712-000	075-02712-000

<sup>s</sup> Recommended Spare Part

# COMPRESSOR IDENTIFICATION

## COMPRESSOR NOMENCLATURE AND NAMEPLATE ENGINEERING DATA

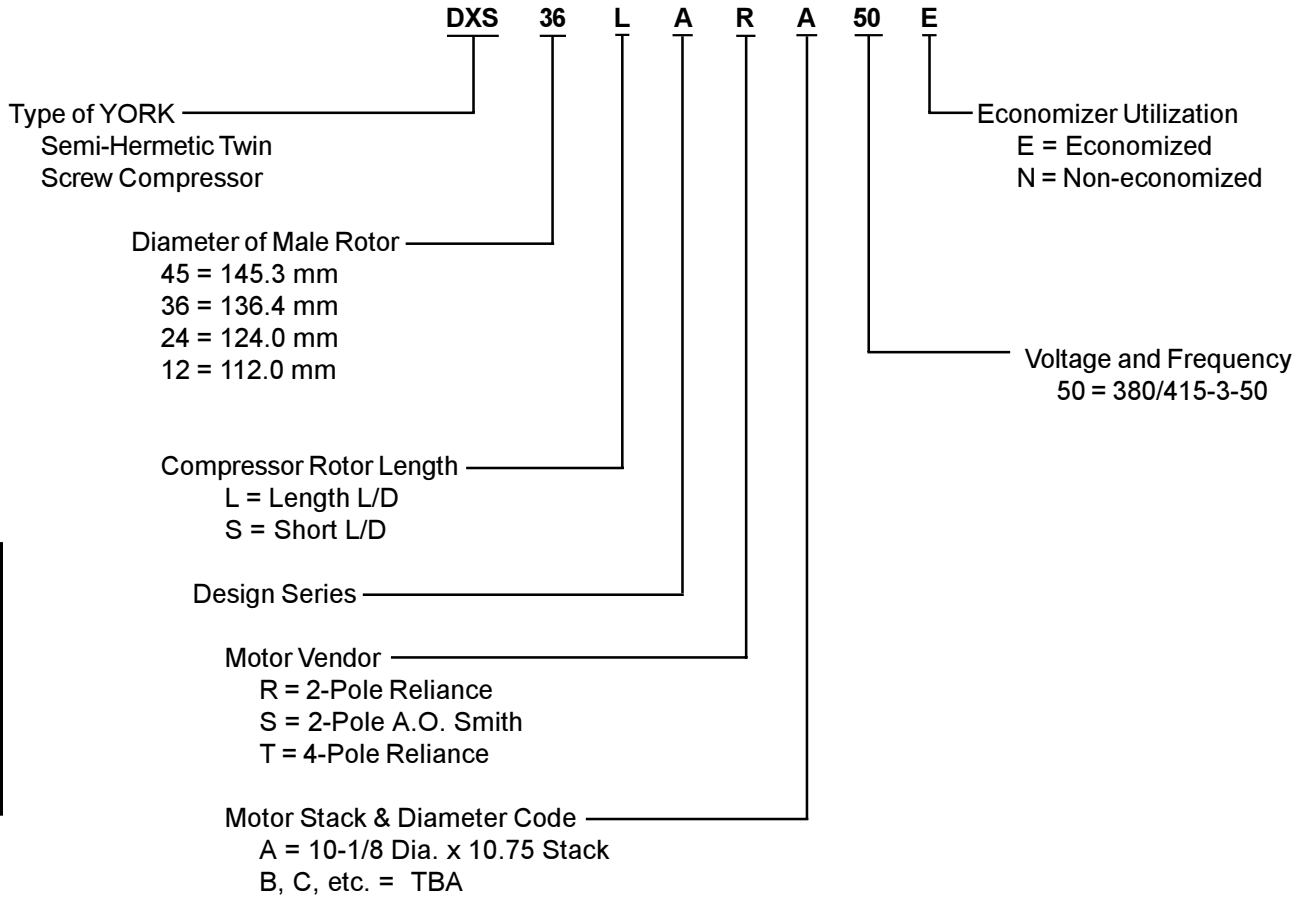

Compressor

COMPRESSOR WEIGHTS		
MM SIZE	WEIGHT (LBS)*	KG
145	1310	594
136	1250	567
124	1175	533
112	760	345

\* LESS SERVICE VALVES

# COMPRESSOR

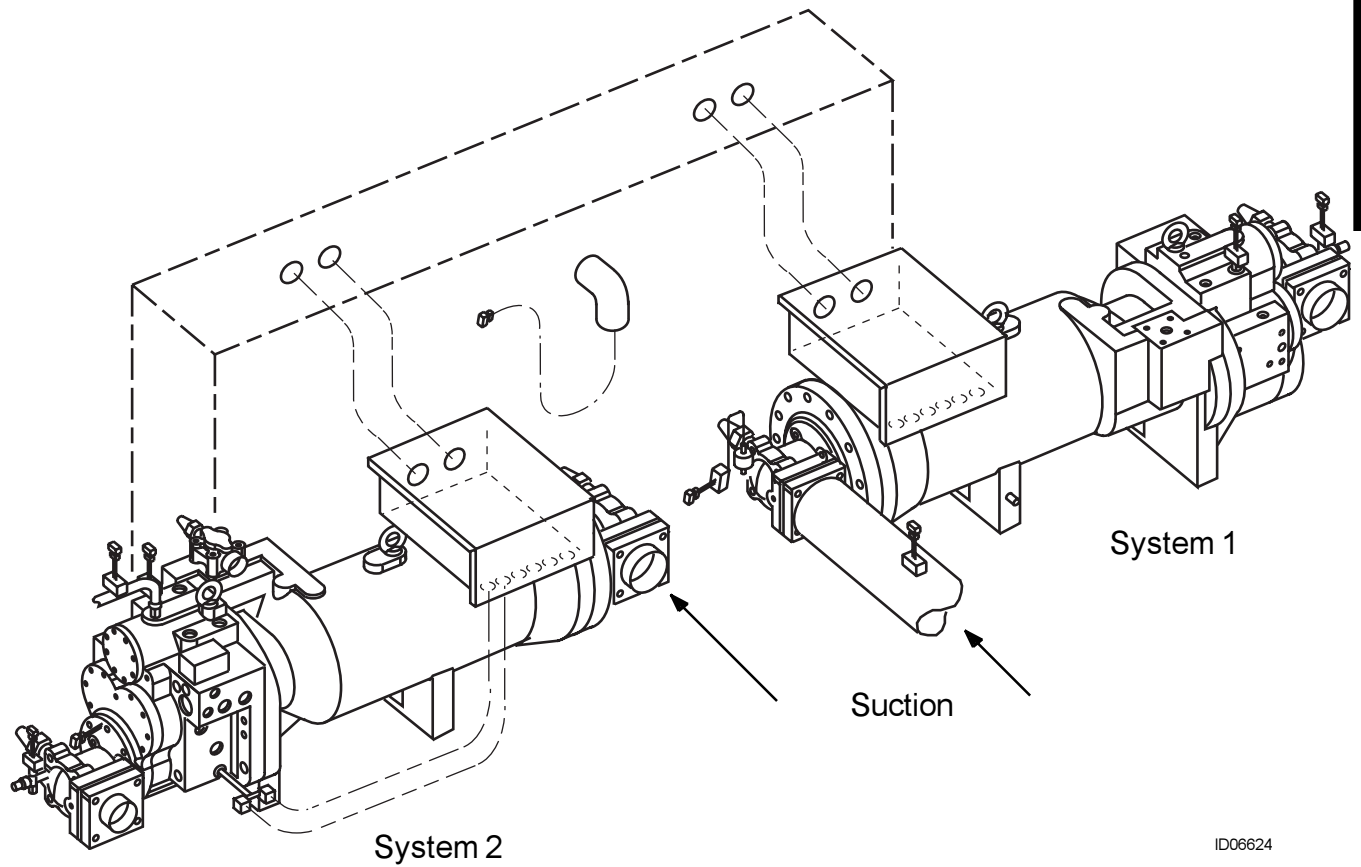
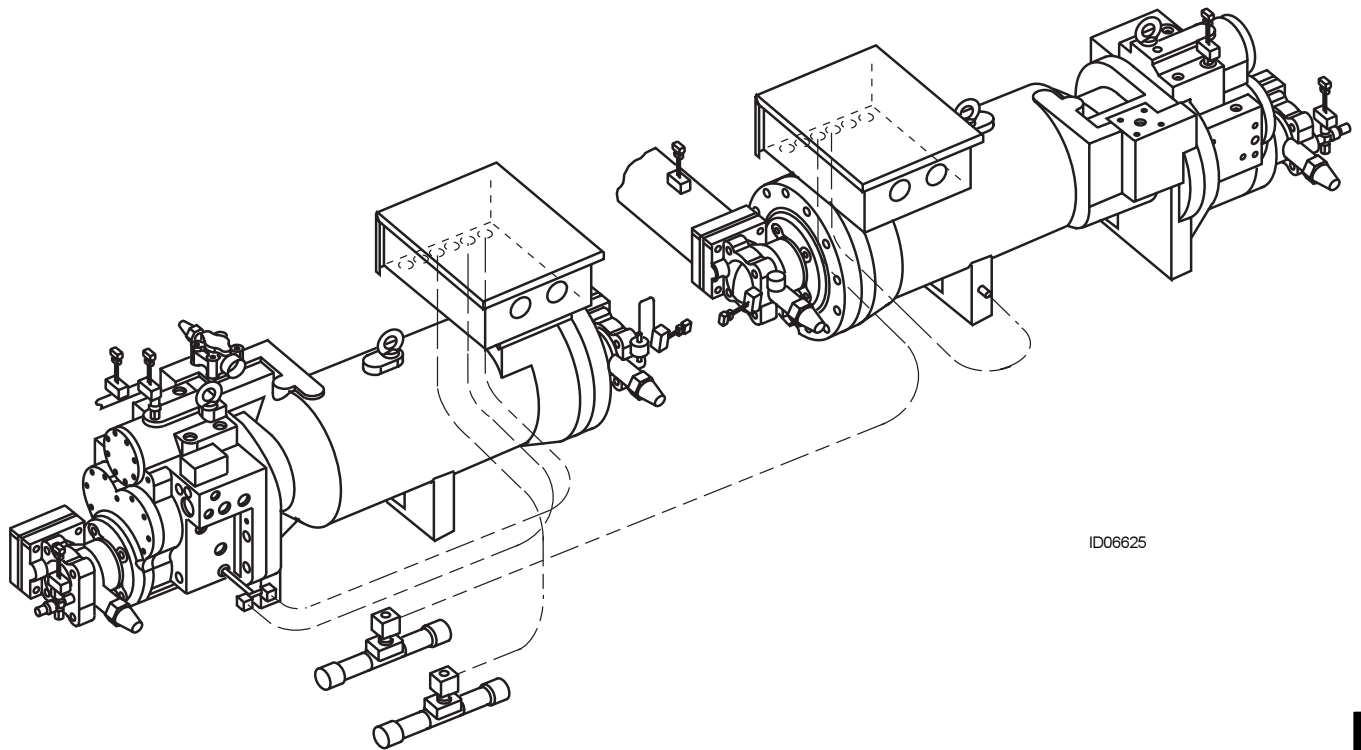

Compressor

FIG. 5 – TYPICAL COMPRESSOR LAYOUT(REF. TABLE 4, PAGE 14)

## COMPRESSOR (CONT'D)

**TABLE 4 – COMPRESSOR PART NUMBERS (SEE FIG. 5 , PAGE 13)**

MODEL	VOLTAGE CODE	QTY		SYSTEM #1 COMPRESSOR		SYSTEM #2 COMPRESSOR	
		SYS 1	SYS 2	PART #	SIZE (MM)	PART #	SIZE (MM)
YCWS0313	-50	1	1	364-49096-215	112mm	364-49096-215	112mm
YCWS0373	-50	1	1	364-49095-215	124mm	364-49096-215	
YCWS0423	-50	1	1	364-49095-215		364-49095-215	124mm
YCWS0503	-50	1	1	364-49095-215		364-49093-215	136mm
YCWS0563	-50	1	1	364-49093-215	136mm	364-49093-215	
YCWS0613	-50	1	1	364-49093-215	145mm	364-49094-215	
YCWS0663	-50	1	1	364-49094-215		145mm	364-49094-215

**TABLE 4a – OIL - R22 AND 407C MODELS**

ITEM	DESCRIPTION	MODEL YCWS0313 - YCWS0663
OIL <sup>s</sup>	OIL, TYPE 'F' (5 GAL)	011-00434-000

<sup>s</sup> Recommended Spare Part

# 112MM COMPRESSOR COMPONENTS

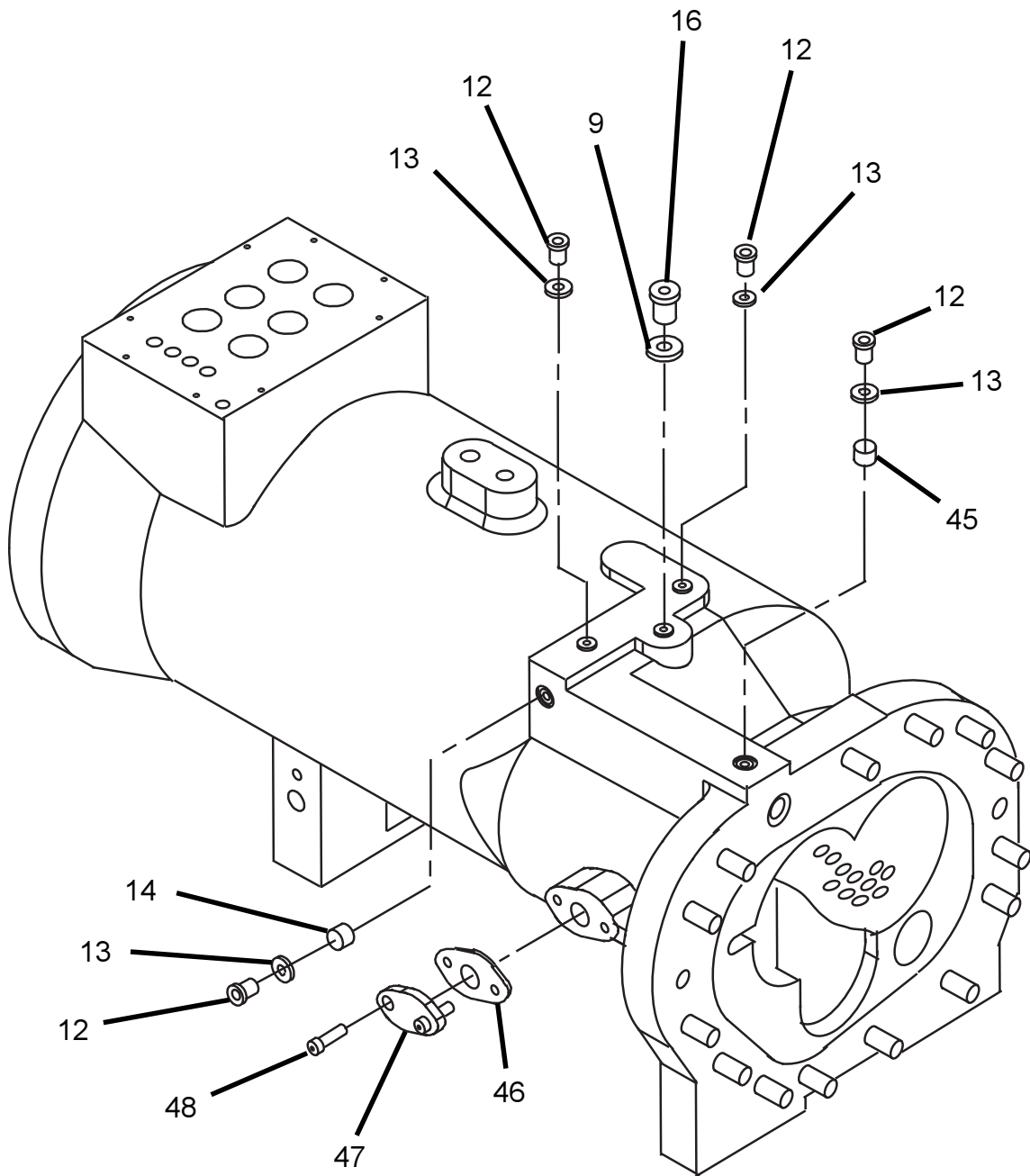

49096-3

Compressor

**FIG. 6 – 112MM DXS COMPRESSOR PARTIAL EXPLODED VIEW (REF. TABLE 5, PAGES 21 AND 22)**

# 112MM COMPRESSOR COMPONENTS (CONT'D)

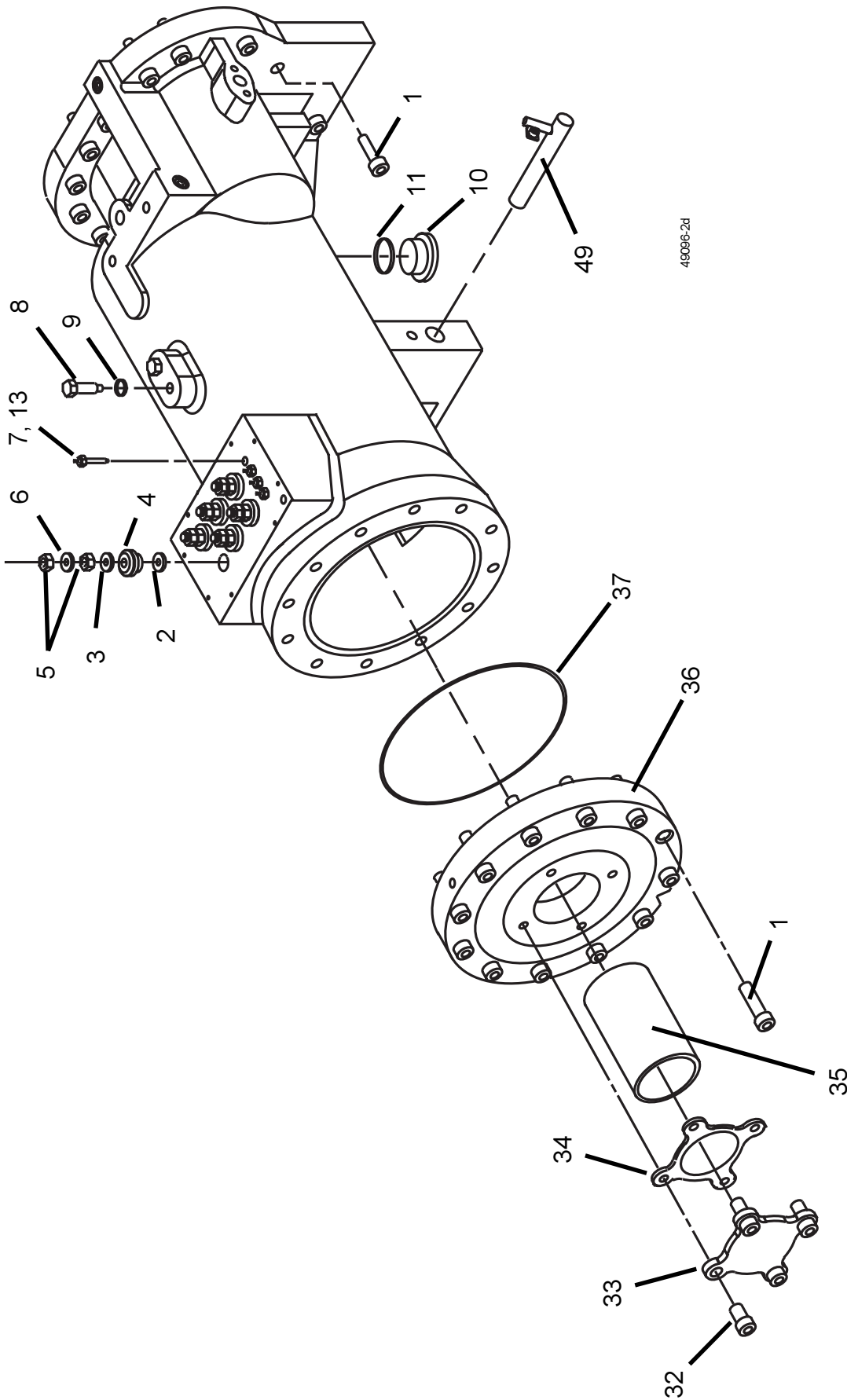

Compressor

FIG. 7 – COMPRESSOR COMPONENTS - 112MM COMPRESSOR (REF. TABLE 5, PAGES 21 AND 22)

# 112MM COMPRESSOR COMPONENTS (CONT'D)

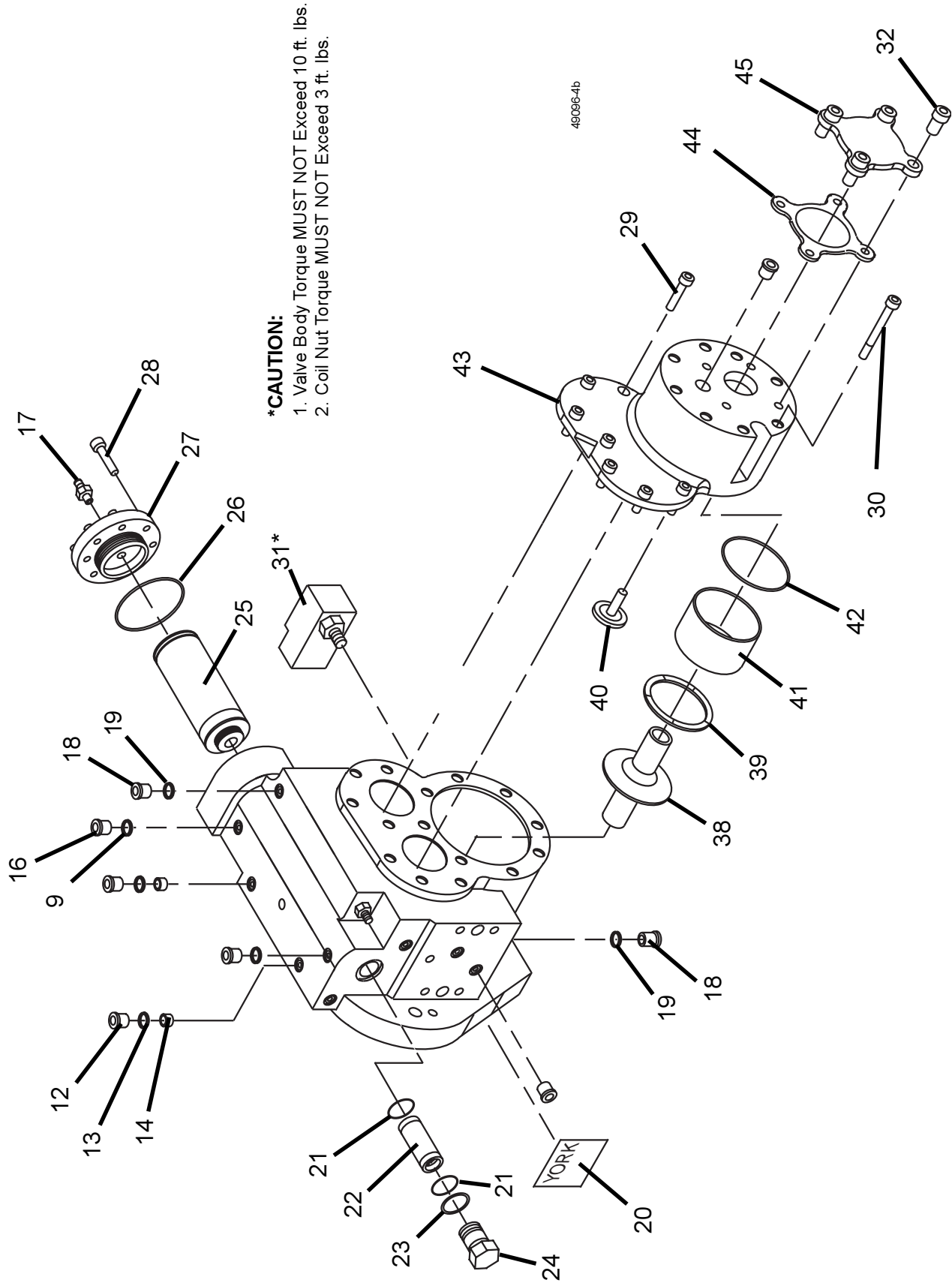

**\*CAUTION:**

1. Valve Body Torque MUST NOT Exceed 10 ft. lbs.
2. Coil Nut Torque MUST NOT Exceed 3 ft. lbs.

# 124MM-145MM COMPRESSOR COMPONENTS

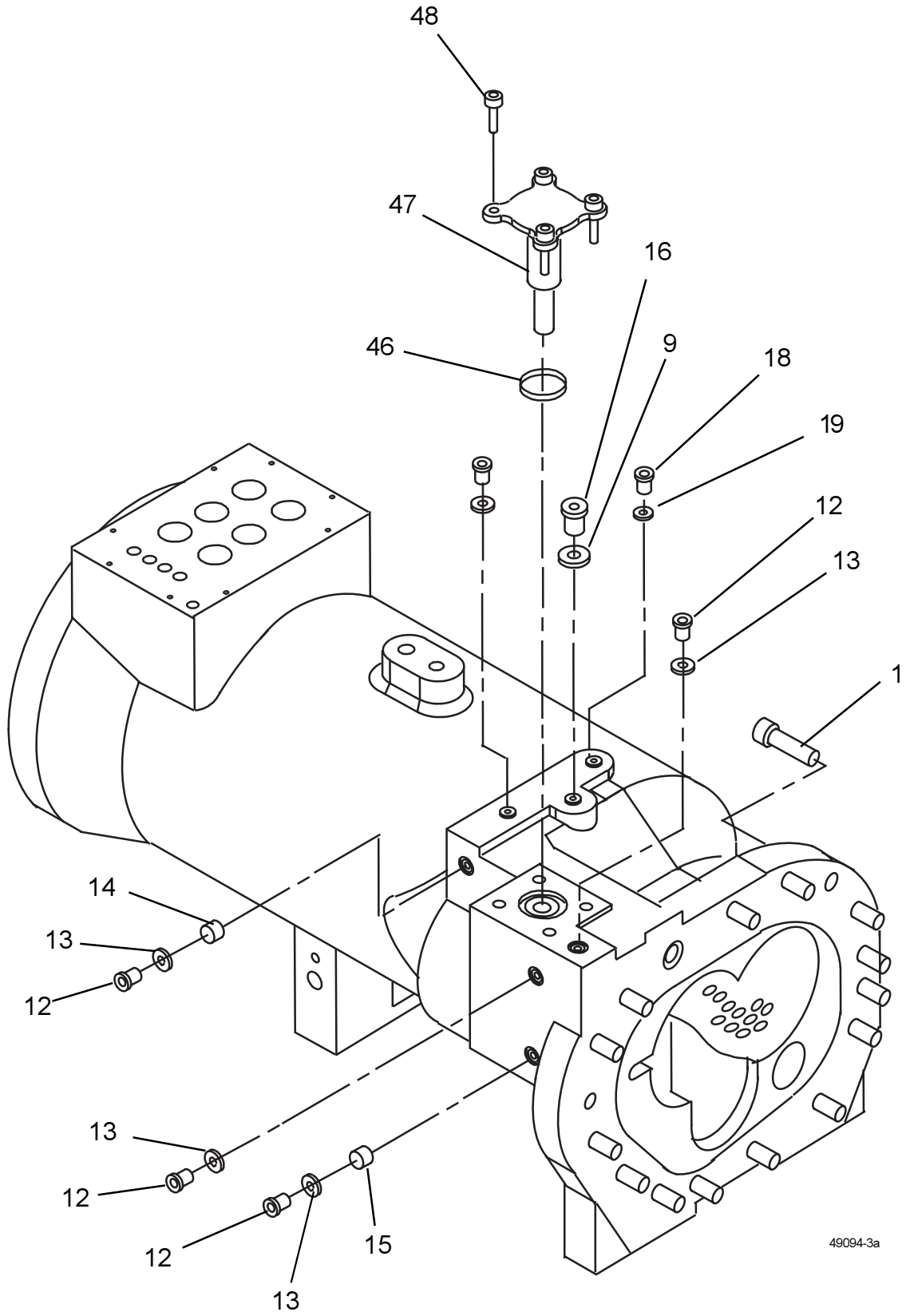

49094-3a

**FIG. 9 – 124MM, 136MM & 145MM DXS COMPRESSOR PARTIAL EXPLODED VIEW (REF. TABLE 5, PAGES 21 AND 22)**

Compressor

### 124MM-145MM COMPRESSOR COMPONENTS (CONT'D)

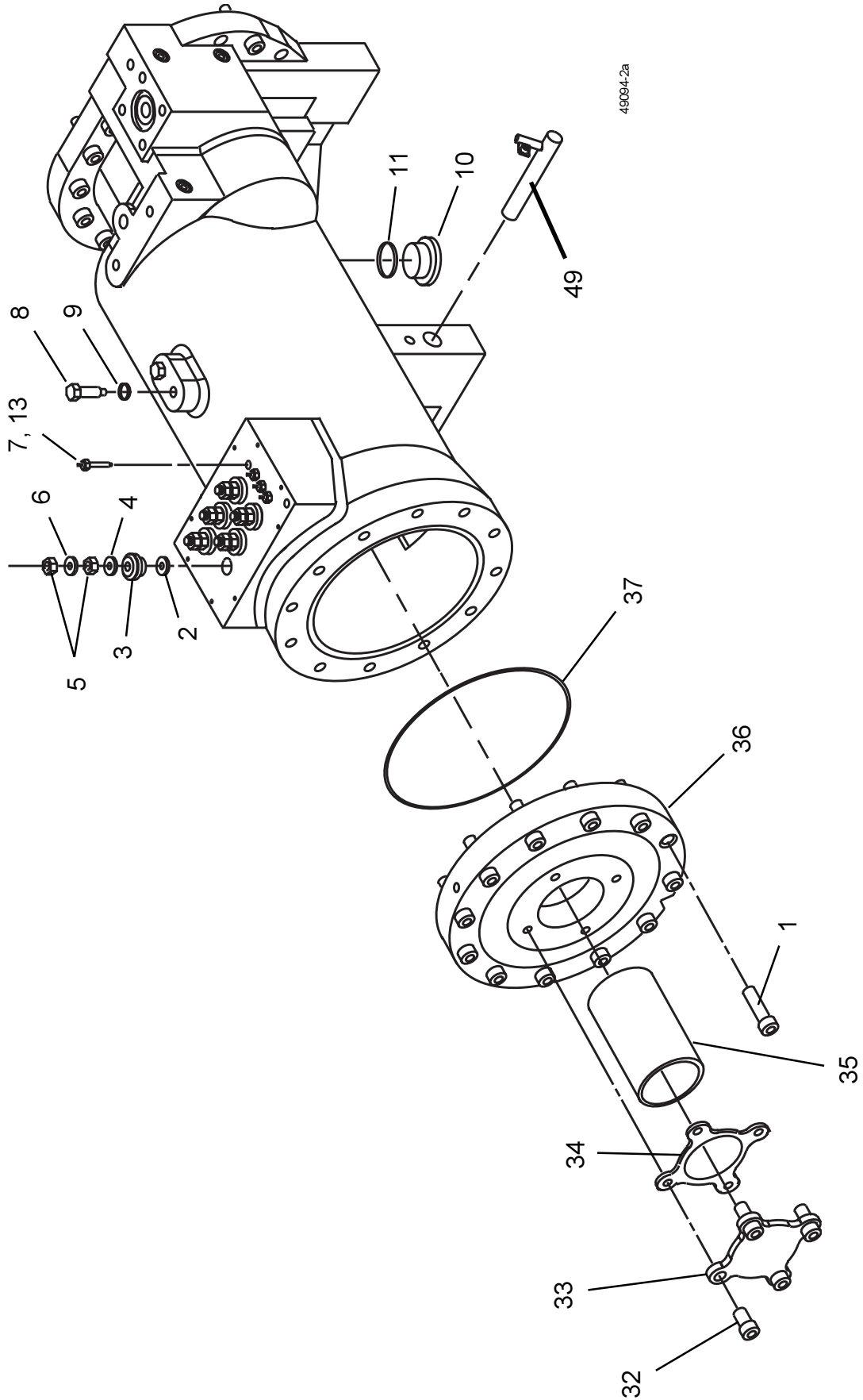

FIG. 10 – COMPRESSOR COMPONENTS - 124MM, 136MM & 145MM COMPRESSOR (REF. TABLE 5, PAGES 21 AND 22)

# 124MM-145MM COMPRESSOR COMPONENTS (CONT'D)

- \*CAUTION:**
1. Valve Body Torque **MUST NOT** Exceed 10 ft. lbs.
  2. Coil Nut Torque **MUST NOT** Exceed 3 ft. lbs.

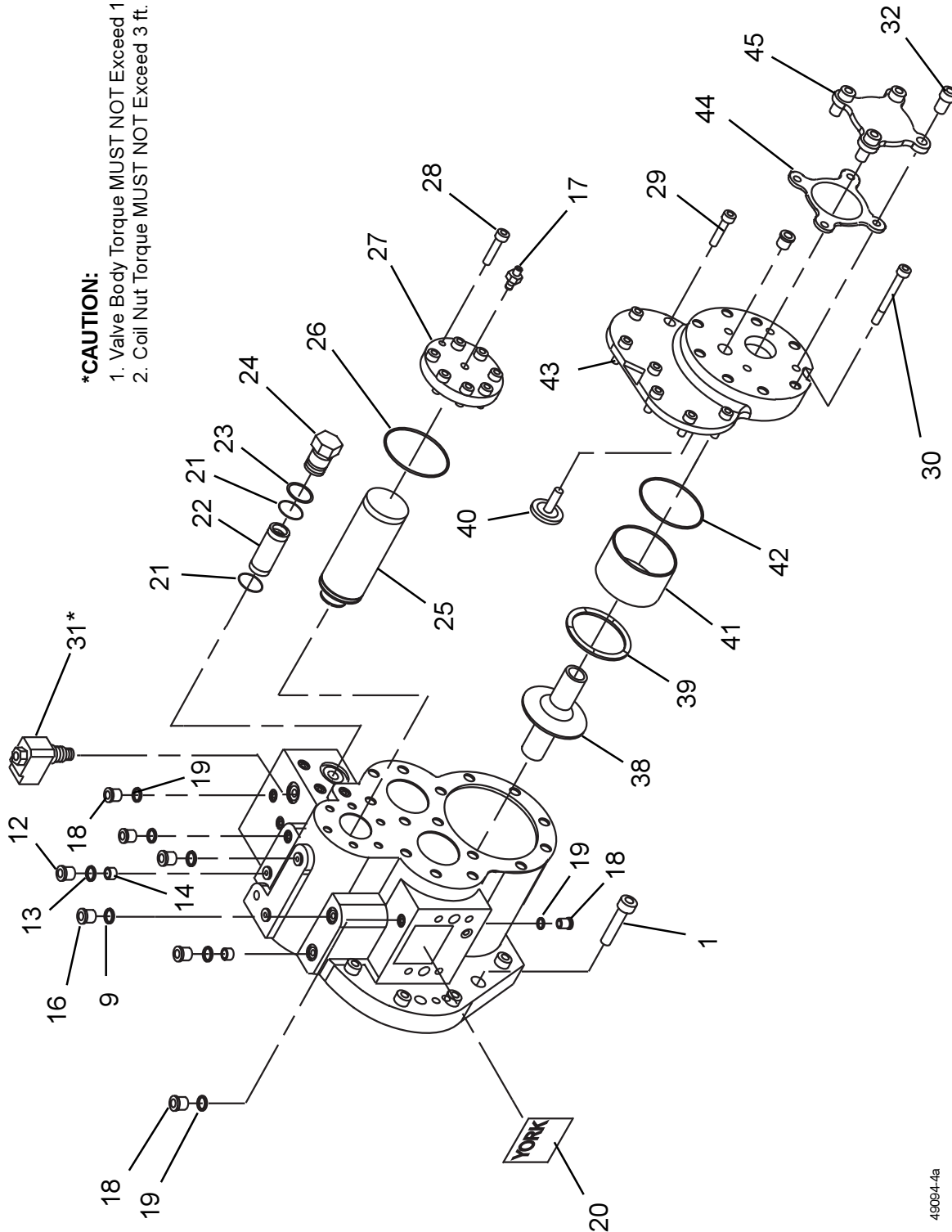

FIG. 11 – COMPRESSOR COMPONENTS - 124MM, 136MM & 145MM COMPRESSOR (REF. TABLE 5, PAGES 21 AND 22)

49094-4a

## 112MM, 124MM, 136MM AND 145MM COMPRESSOR COMPONENTS

**TABLE 5 – 112MM, 124MM, 136MM & 145MM COMPRESSOR COMPONENTS**  
(SEE FIGS. 6 - 11, PAGES 15 - 20)

ITEM NO.	PART DESCRIPTION	PART NO. (QTY)
1	SCREW, SOCKET HD. CAP - M16 X 65MM LG.	021-19108-000 (26)
2	SEAL, TERMINAL	028-13946-000 (6)
3	INSULATOR, TOP	025-33201-000 (6)
4	WASHER, TERMINAL	021-19117-000 (6)
5	NUT, HEAVY HEX - 7/16" - 20UNF	021-19102-000 (12)
6	WASHER, LOCK - 7/16"	021-19619-000 (6)
7	THERMISTOR, 7/16" - 20UNF - 2A	025-33202-000 (4)
8	PIN, STATOR LOCKING (112MM)	064-49129-000
	PIN, STATOR LOCKING (124MM, 136MM & 145MM)	064-49954-000
9	O-RING 3 - 908	028-13856-000 (4)
10	PLUG, HOLLOW HEX - 1 7/8"	023-18926-000
11	O-RING 3 - 924	028-13865-000
12	PLUG - HOLLOW HEX 9/16" (112MM)	023-18922-000 (6)
	PLUG - HOLLOW HEX 9/16" (124MM, 136MM & 145MM)	023-18922-000 (8)
13	O-RING3 - 906 (112MM)	028-13855-000 (6)
	O-RING3 - 906 (124MM, 136MM & 145MM)	028-13855-000 (8)
14	PLUG- 0.032 ORIFICE	029-22716-000 (3)
15	PLUG - 0.093 ORIFICE (112MM)	029-22994-000 (1)
	PLUG - 0.093 ORIFICE (124MM, 136MM & 145MM)	029-22994-000 (2)
16	PLUG, HOLLOW HEX - 3/4" (112MM)	023-18923-000 (3)
	PLUG, HOLLOW HEX - 3/4" (124MM, 136MM, 145MM)	023-18923-000 (7)
17	VALVE, ACCESS 7/16"	022-09715-000
18	PLUG, HOLLOW HEX - 7/16" (112MM)	023-18921-000 (9)
	PLUG, HOLLOW HEX - 7/16" (124MM, 136MM, 145MM)	023-18921-000 (15)
19	O-RING 3 - 904 (112MM)	028-13854-000 (9)
	O-RING 3 - 904 (124MM, 136MM, 145MM)	028-13854-000 (15)
20	PLATE, DATA	029-22722-000
21	O-RING 2 - 023	028-13859-000 (2)
22	VALVE, OIL CONTROL	022-09710-000
23	O-RING 3 - 916	028-13857-000
24	PLUG, OIL RETURN VALVE	064-49135-000
25 <sup>s</sup>	ELEMENT, OIL FILTER	026-35601-000
26 <sup>s</sup>	O-RING 2 - 152	028-13849-000
27	COVER, OIL FILTER	064-49003-000
28	SCREW, SOCKET HD. CAP - M8 X 30MM LG.	021-19115-000 (8)
29	SCREW, SOCKET HD. CAP - M10 X 45MM LG. (112MM)	021-19617-000 (7)
	SCREW, SOCKET HD. CAP - M10 X 45MM LG. (124MM, 136MM, 145MM)	021-19112-000 (9)
30	SCREW, SOCKET HD. CAP - M10 X 60MM LG. (112MM)	021-19616-000 (8)
	SCREW, SOCKET HD. CAP - M10 X 60MM LG. (124MM, 136MM, 145MM)	021-19113-000 (8)
31 <sup>s</sup>	VALVE, CAPACITY CONTROL	025-33205-000
32	SCREW, SOCKET HD. CAP - M16 X 30MM LG. (112MM)	021-19118-000 (4)
	SCREW, SOCKET HD. CAP - M16 X 30MM LG. (124MM, 136MM, 145MM)	021-19118-000 (8)
33	PLATE, VALVE COVER (112MM, 124MM)	064-49008-000
	PLATE, VALVE COVER (136MM, 145MM)	064-49009-000
34	GASKET, 3" (112MM, 124MM)	028-13863-000
	GASKET, 3 1/2" (136MM, 145MM)	028-13864-000
35	STRAINER, SUCTION (112MM, 124MM)	026-35623-000
	STRAINER, SUCTION (136MM, 145MM)	026-35600-000

**112MM, 124MM, 136MM & 145MM COMPRESSOR COMPONENTS (CONT'D)****TABLE 5 (CONT'D) – 112MM, 124MM, 136MM & 145MM COMPRESSOR ASSEMBLY**  
(SEE FIGS. 6 - 11, PAGES 15 - 20)

ITEM NO.	PART DESCRIPTION	PART NUMBER (QTY)
36	COVER, SUCTION (124MM)	064-49437-000
	COVER, SUCTION (124MM)	064-49375-000
	COVER, SUCTION (136MM, 145MM)	064-49198-000
37	O-RING 2 - 276	028-13852-000 (2)
38	ORIFICE, MUFFLER (112MM)	064-49515-000
	ORIFICE, MUFFLER (124MM)	064-49518-000
	ORIFICE, MUFFLER (136MM, 145MM)	064-49516-000
39	SPRING, MUFFLER PRELOAD (112MM)	029-22912-000
	SPRING, MUFFLER PRELOAD (124MM)	029-22902-000
	SPRING, MUFFLER PRELOAD (136MM, 145MM)	029-22904-000
40	BUTTON, CHECK VALVE (112MM)	064-49507-000
	BUTTON, CHECK VALVE (124MM)	064-49521-000
	BUTTON, CHECK VALVE (136MM)	064-49517-000
	BUTTON, CHECK VALVE (145MM)	064-49504-000
41	SPACER, MUFFLER (112MM)	064-49514-000
	SPACER, MUFFLER (124MM)	064-49520-000
	SPACER, MUFFLER (136MM, 145MM)	064-49513-000
42	O-RING 2 - 155 (112MM)	028-13962-000
	O-RING 2 - 158 (124MM)	028-13603-000
	O-RING 2 - 161 (136MM, 145MM)	028-13851-000
43	COVER, DISCHARGE (112MM)	064-49123-000
	COVER, DISCHARGE (124MM)	064-49126-000
	COVER, DISCHARGE (136MM)	064-48990-000
	COVER, DISCHARGE (145MM)	064-49005-000
44	GASKET, 2" (112MM)	028-13862-000
	GASKET, 2" (124MM)	028-13902-000
	GASKET, 3" (136MM, 145MM)	028-13863-000
45	PLATE, VALVE COVER (112MM)	064-49010-000
	PLATE, VALVE COVER (124MM)	064-49379-000
	PLATE, VALVE COVER (136MM, 145MM)	064-49008-000
46	GASKET, 7/8" (112MM)	028-13948-000
	O-RING 2 - 136 (124MM)	028-13863-000
	O-RING 2 - 139 (136MM, 145MM)	028-13963-000
47	PLATE, ECONOMIZER (112MM)	064-49441-000
	PLUG, ECONOMIZER (124MM)	064-50004-000
	PLUG, ECONOMIZER (136MM, 145MM)	064-50003-000
48	SCREW, SOCKET HD. CAP - M8 X 25MM LG. (112MM)	021-19615-000
	SCREW, SOCKET HD. CAP - M12 X 25MM LG. (124MM, 136MM, 145MM)	021-30148-000
49	HEATER, 350 WATTS	025-32938-000

This page intentionally left blank

Compressor

# CONTROL PANEL, OPTION PANEL AND POWER PANEL

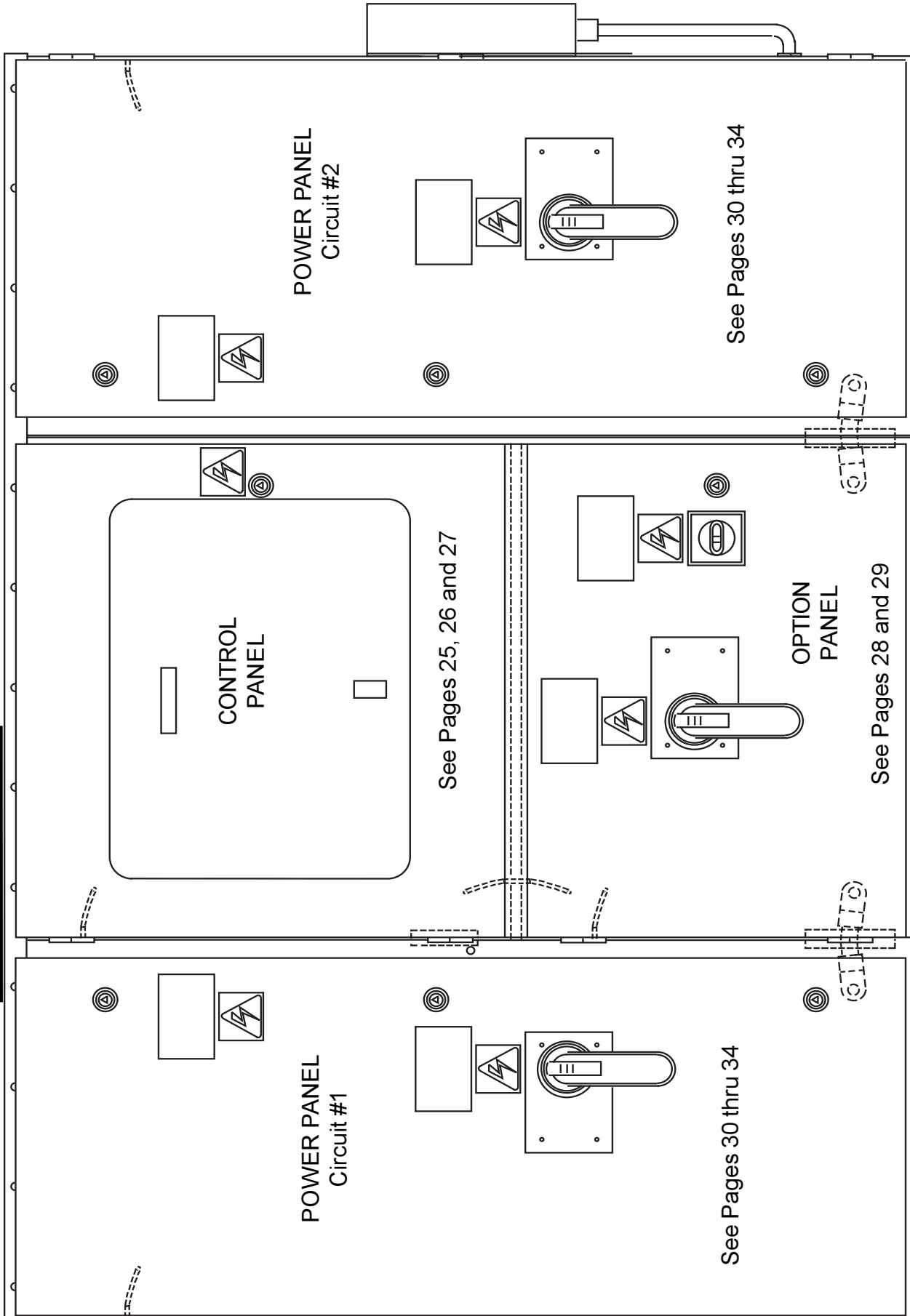
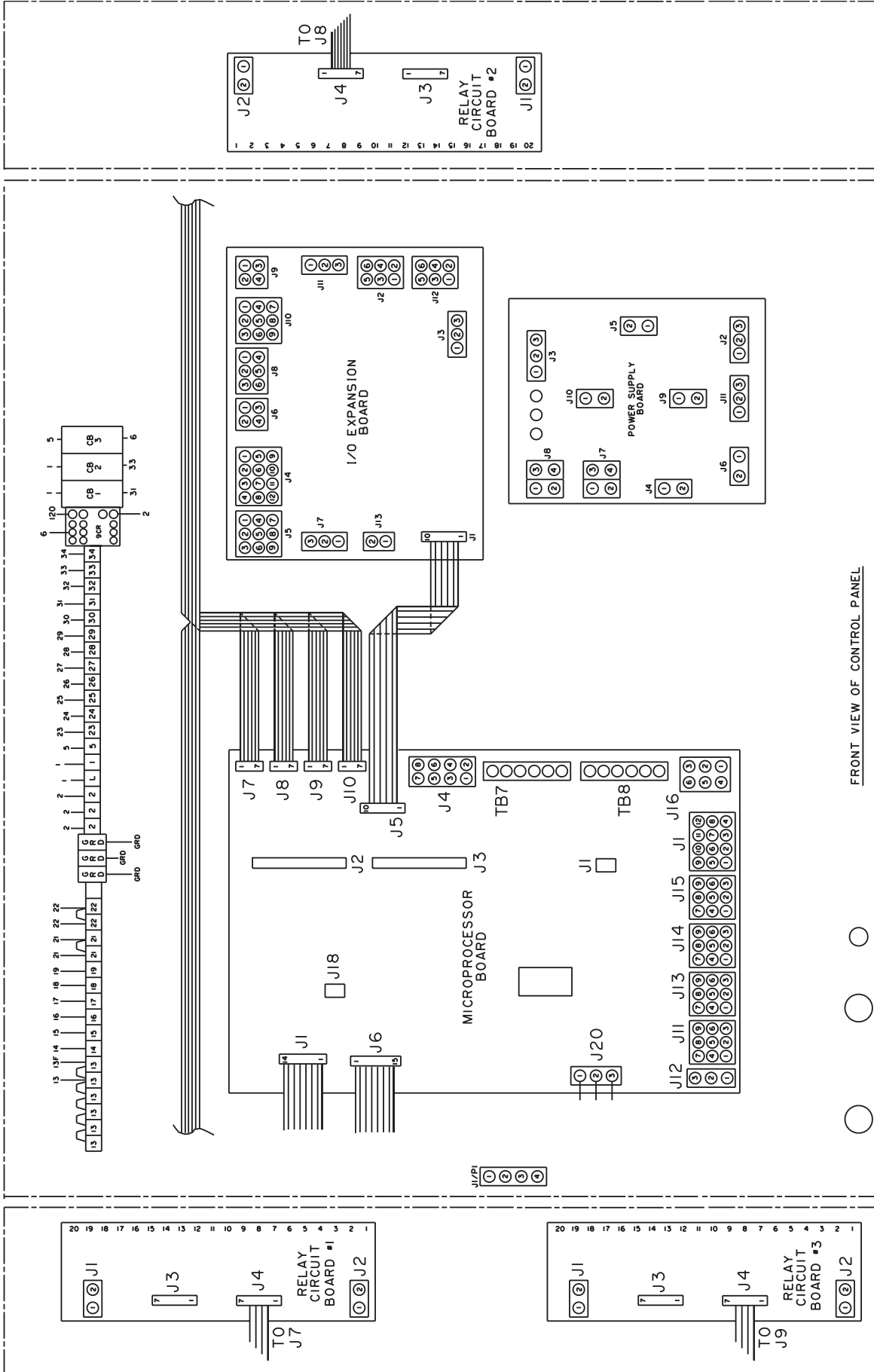

FIG. 12 – CONTROL PANEL, OPTIONS PANEL AND POWER PANEL



# CONTROL PANEL COMPONENTS (CONT'D)



02492-1d

FIG. 13A – CONTROL PANEL COMPONENTS (REF. TABLE 6, PAGE 27)

## CONTROL PANEL COMPONENTS (CONT'D)

**TABLE 6 – CONTROL PANEL COMPONENTS (SEE FIGS. 13, 13A AND 13B, PAGES 25 - 27)**

ITEM NO.	QUANTITY	DESCRIPTION	PART NO.	NOTE	
1	1	Door For Micro-Compartment	RAM-201704		
	1	Door for Options Compartment	RAM-201733		
<sup>s</sup> 4A	1	Micro Processor Board	031-01095-002		
<sup>s</sup> 4B	1	EPROM	031-01798-001		
<sup>s</sup> 4C	1	I/O Expansion Board	031-01781-000		
<sup>s</sup> 4D	1	Power Supply Board	031-01094-000		
4E	1	Ribbon Cable	031-01724-211		
4F	1	Ribbon Cable	071-02667-000		
4G	1	Ribbon Cable	071-02667-000		
4J	1	Ribbon Cable	071-02253-251		
4K	1	Ribbon Cable	071-02253-253		
4S	16	Terminal Block	025-34188-000		
4U	1	Display	031-02100-000		
4Z	1	Switch, On/Off	024-25517-000		
<sup>s</sup> 11	3	Relay Circuit Board	031-01093-000		
16	3	Circuit Breaker, 6A	025-34438-000		
21	1	Keypad	024-30910-000		
40	Varies	Plug, 3 Pin	025-29185-000		See Fig. 13B
41	Varies	Plug, 6 Pin	025-28382-000		
42	Varies	Plug, 9 Pin	025-28383-000		
43	Varies	Plug, 12 Pin	025-28384-000		
44	Varies	Socket, Wire End	025-28386-000	Use with Plugs 40, 41, 42, 43	
45	1	Real Time Clock (includes battery)	031-00955-000		

<sup>s</sup> Recommended Spare Part

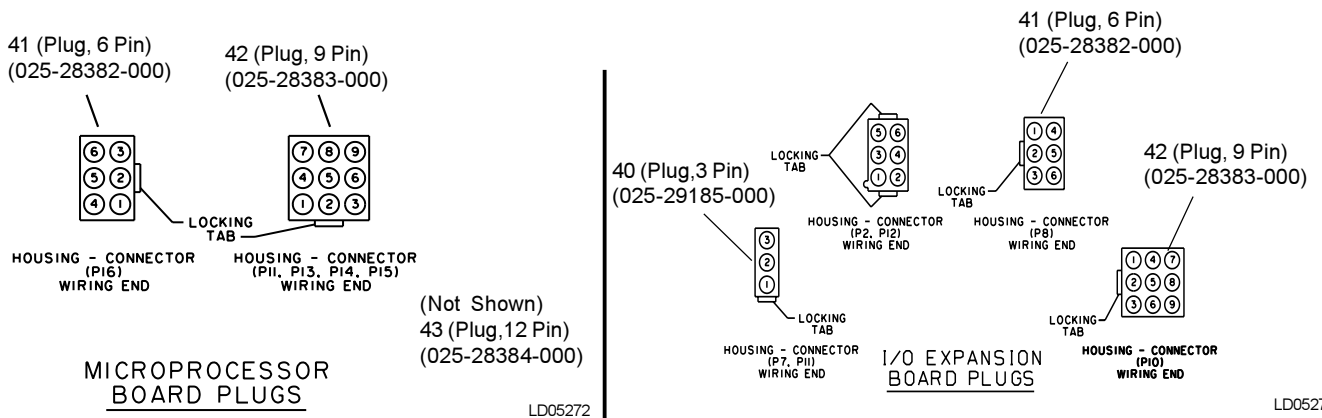

**Control & Power Panel**

**FIG. 13B – SENSOR HOUSING PART NUMBERS (REF. TABLE 6)**

# OPTION PANEL COMPONENTS

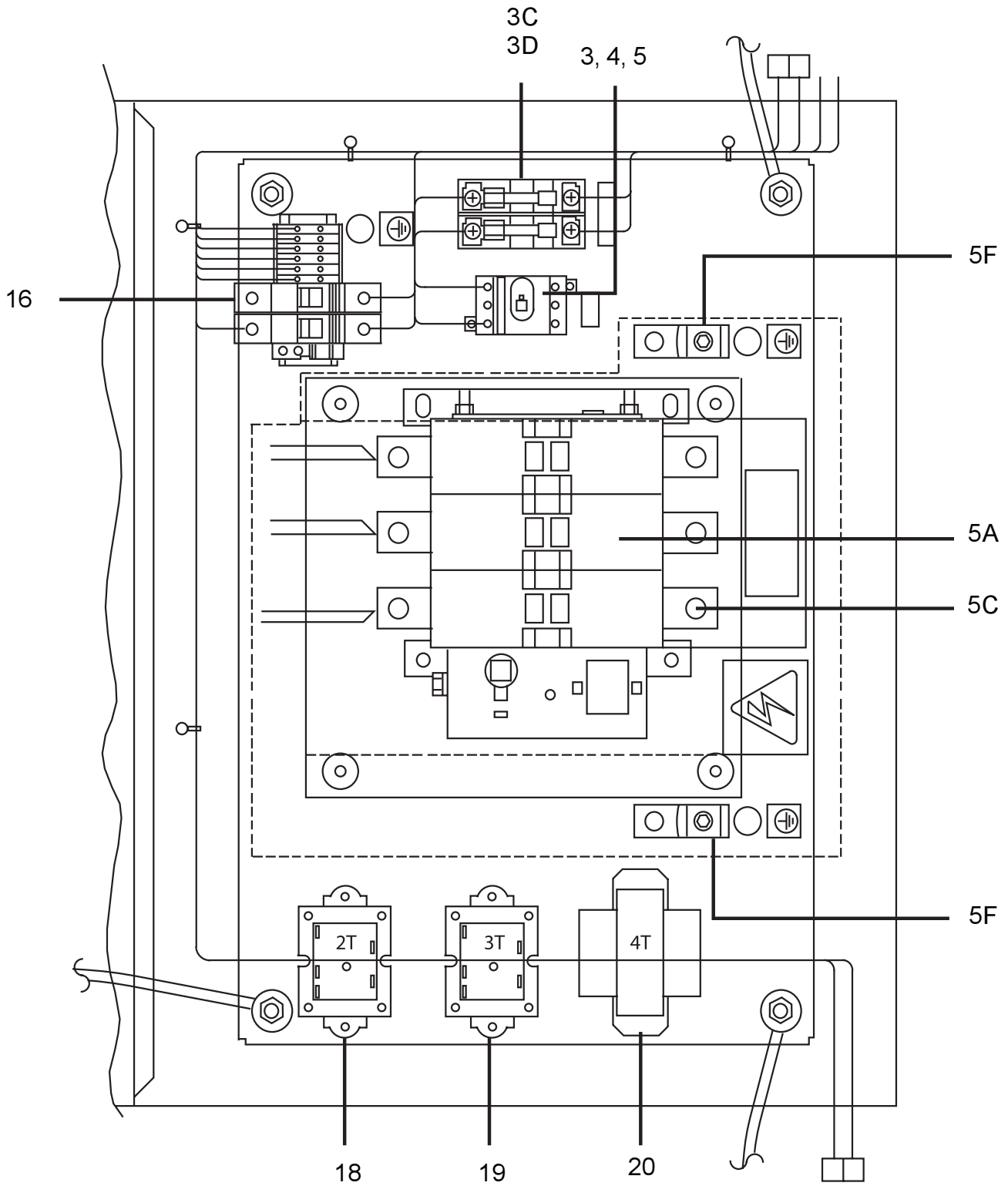

202515-1

FIG. 14 – OPTION PANEL COMPONENTS (REF. TABLE 7, PAGE 29)

## OPTION PANEL COMPONENTS (CONT'D)

**TABLE 7 – OPTION PANEL COMPONENTS (SEE FIGS. 14 AND 14A, PAGES 28 - 29)**

ITEM NO.	QUANTITY	DESCRIPTION	PART NO.	NOTE
3	1	Switch, Control Power	024-31833-000	115V
3A	1	Control Transformer	025-34493-000	2KVA
3C	2	Fuse Block	025-34427-000	2P-30A
3D	2	Fuse	025-34435-000	(F7, F8) 600V
4	1	Handle	024-31633-000	Use with #3
5	1	Shaft	024-31832-000	
5A	1	NF Disconnect Switch (Single Point)	024-30963-000	S4H250DW
			024-30964-000	S5H400DW
			024-30965-000	S6H600DW
			024-31870-000	S3H225DW
			024-31888-000	S3H150DW
	1	Terminal Block (Single Point)	025-34405-000	UKH-240
			025-34408-000	UKH-150
			025-34454-000	UKH-95
5B	1	Operator Mechanism	024-31878-000	Handle and Shaft for NF Disc. Sw.
5C	1	Lug Kit (NF Disconnect Switch)	025-34414-000	250 to 500 KCMIL (600A)
			025-34418-000	6AWG to 350 KCMIL (250A)
			025-34420-000	3/0 to 250 KCMIL (400A)
			025-34479-000	2AWG to 4/0 (150A)
			025-34480-000	4AWG to 300 KCMIL (225A)
			025-34481-000	(600A)
5F	1	Ground Lug	025-34085-000	#4-3/0AWG
			025-34088-000	
			025-34089-000	#6-1/0AWG
16	2	Circuit Breaker, 115V	025-34438-000	S271-K6
18	1	Control Transformer, 4T (120/24V)	025-30889-000	
19	1	Control Transformer, 3T (208/24V)	025-18452-000	
20	1	Control Transformer, 2T	025-27911-000	

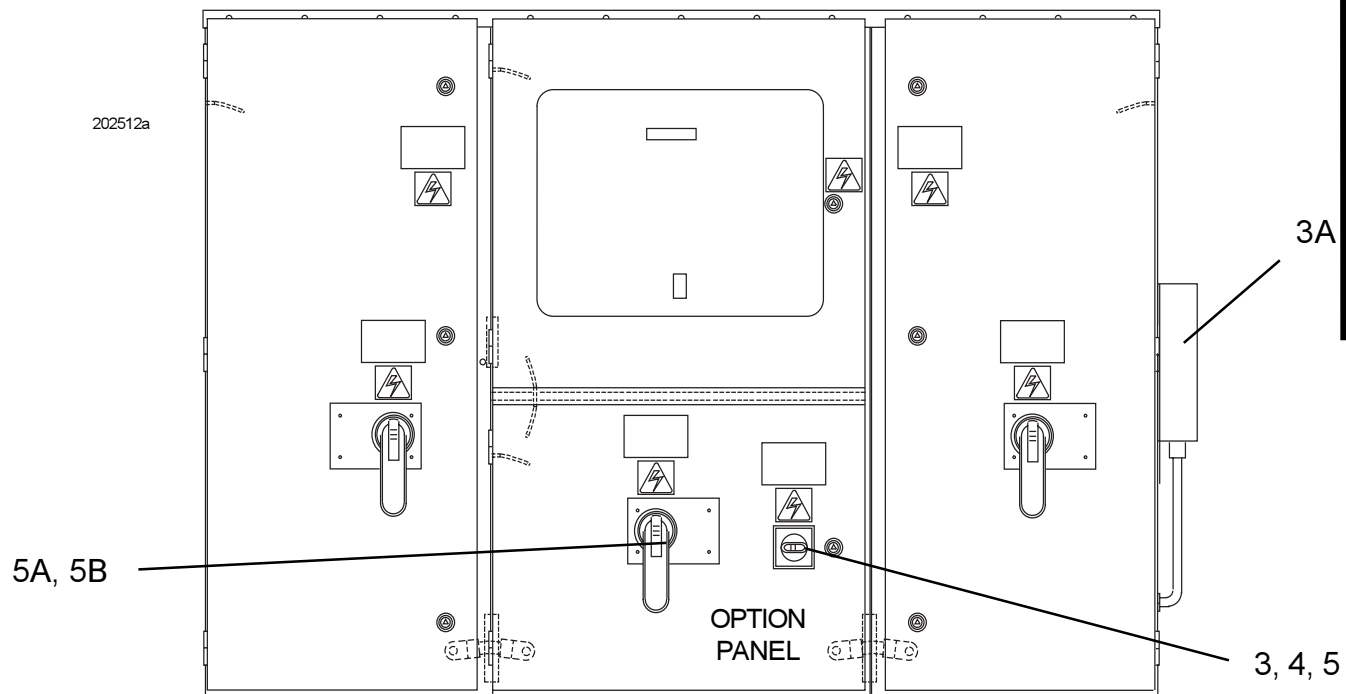

**FIG. 14A – OPTION PANEL COMPONENTS (REF. TABLE 7, ABOVE AND SEE FIG. 14, PAGE 28)**

## POWER PANEL AND OPTIONS PANEL CONFIGURATION

Power panels and option panels are offered in several configurations using three (3) major components:

1. TERMINAL BLOCKS -
2. CIRCUIT BREAKER SWITCH -
3. NF (Non Fused) DISCONNECT SWITCH -

The most basic chiller power wiring configuration uses terminal blocks in the power panel, and an option panel with no power wire termination hardware. See figures below. The model number pin number locations 16 and 17 would be X and X to reflect this basic combination. Identify pin number locations 16 and 17 to identify the chiller power wiring connections and hardware listed below.

**TABLE 8 – POWER PANEL AND OPTION PANEL CONFIGURATIONS**

PIN 16 & 17 LETTER CODE IDENTIFIERS	POWER PANEL AND OPTION PANEL CONFIGURATIONS
X X	Standard Power option
M D	MP Non-Fused Disconnect Switches
M B	MP supply w/ Separate System Circuit Breakers
S S	SP supply Terminal Block w/ Separate System Non-Fused Disconnect Switches
S B	SP supply Terminal Block w/ Separate System Circuit Breakers
D B	SP supply Non-Fused Disconnect Switches w/ Separate System Circuit Breakers
F B	SP supply Non-Fused Disconnect Switches w/ Separate System Fuses

# POWER PANEL COMPONENTS

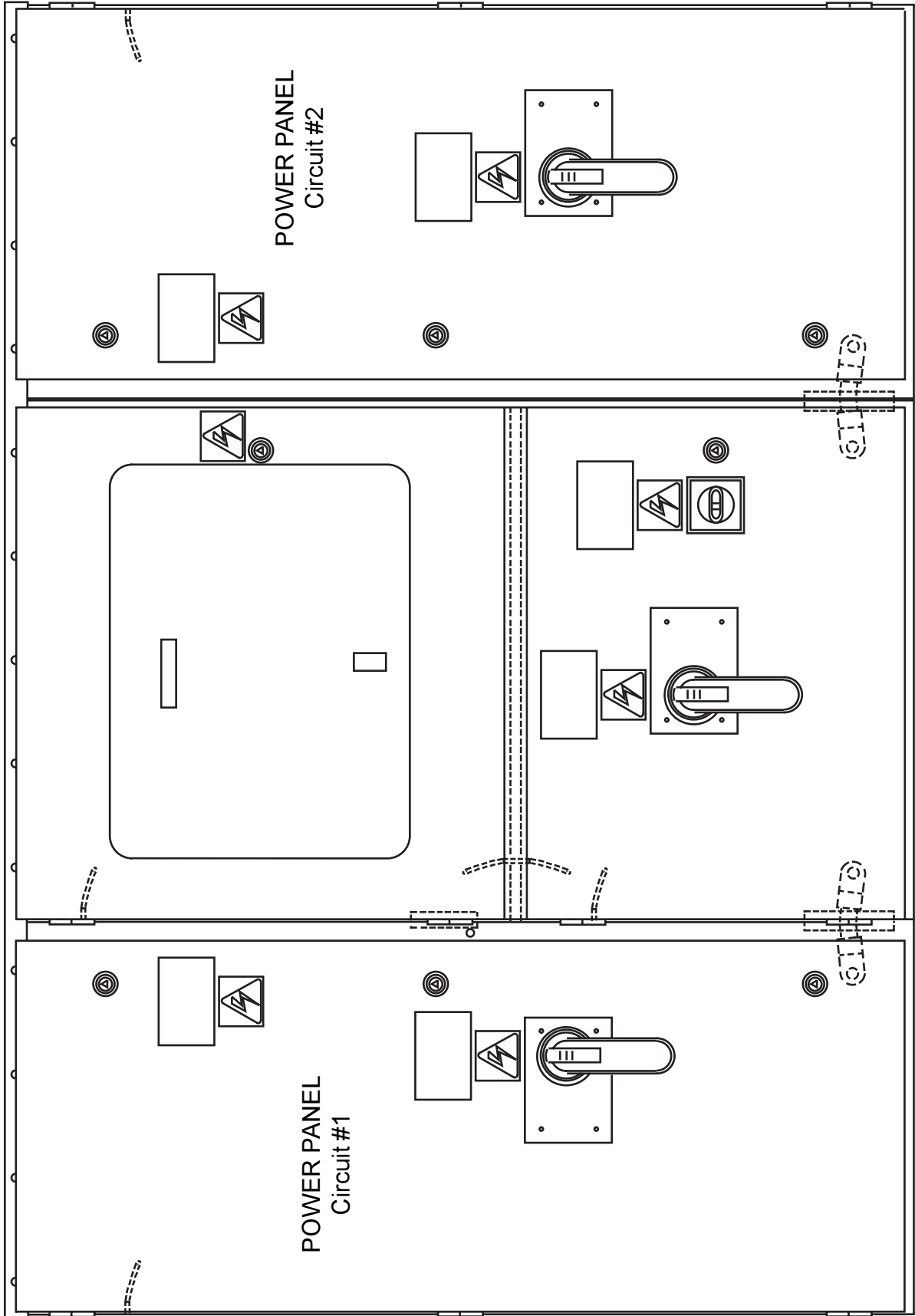

202512

FIG. 15 -- POWER PANELS (REF. TABLE 9, PAGE 34)

**Control & Power Panel**

## POWER PANEL COMPONENTS (CONT'D)

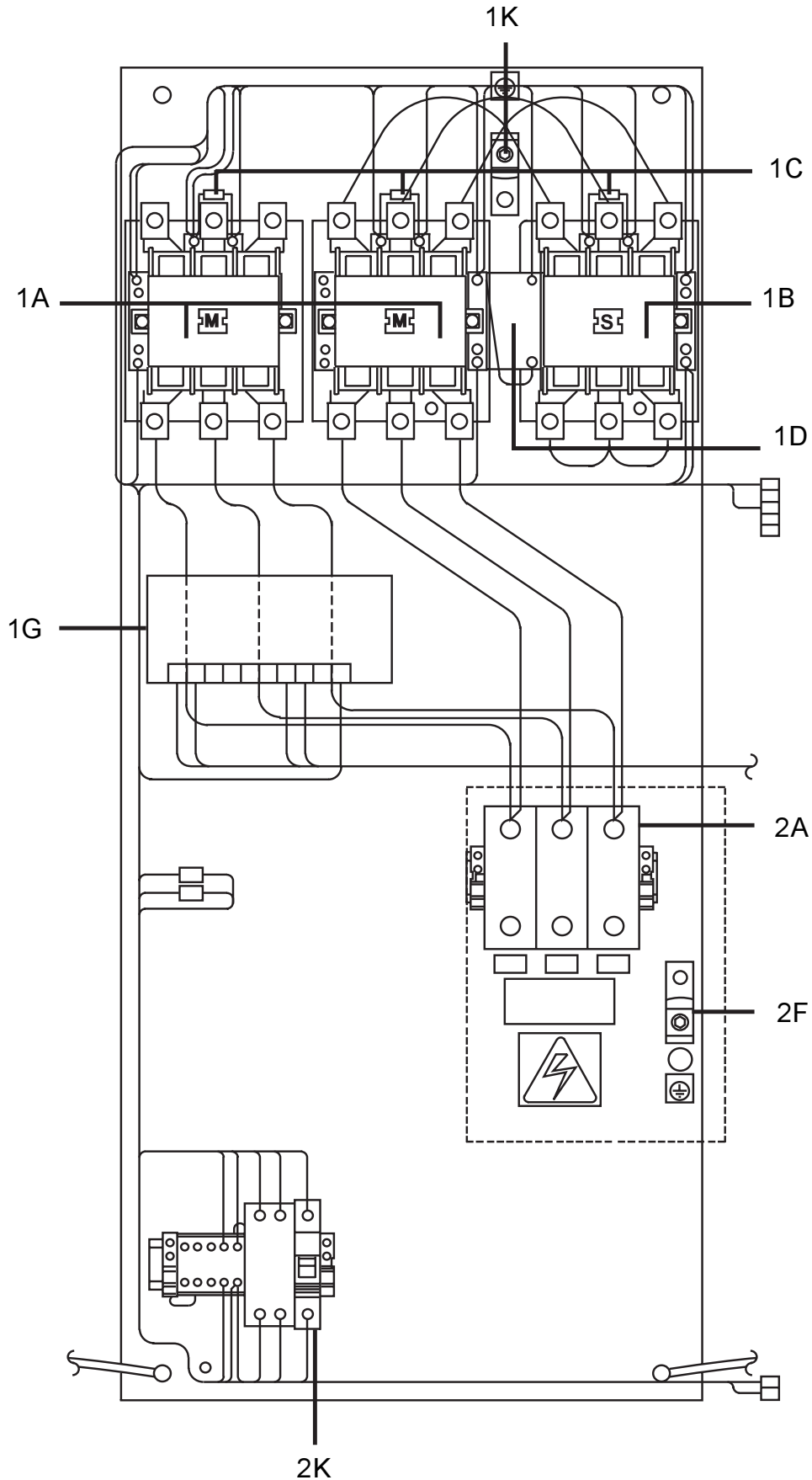

Control & Power Panel

FIG. 15A – POWER PANEL COMPONENTS (REF. TABLE 9, PAGE 34)

202513-1

### POWER PANEL COMPONENTS (CONT'D)

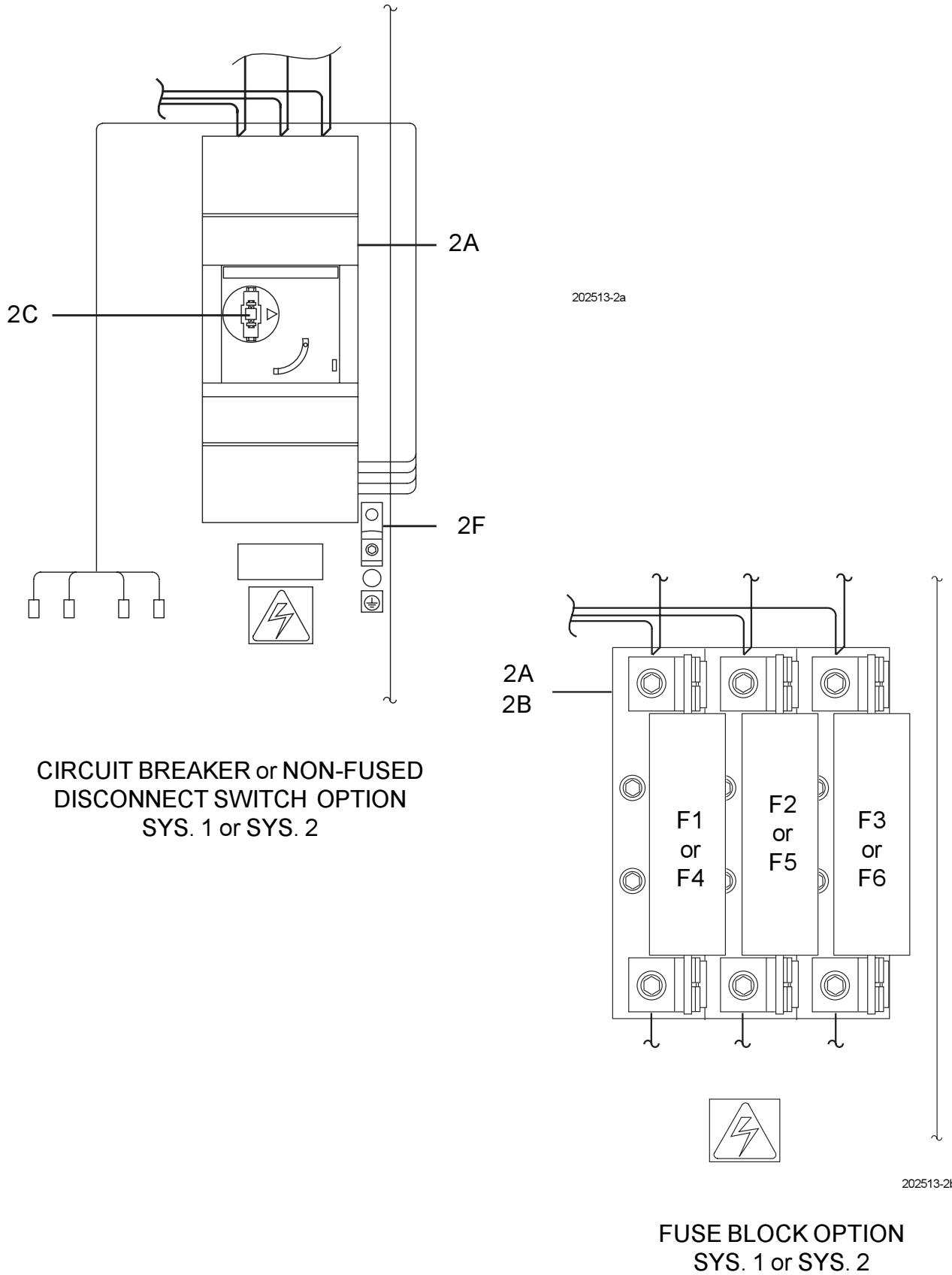

**FIG. 15B – POWER PANEL COMPONENTS (REF. TABLES 9, PAGE 34)**

## POWER PANEL COMPONENTS (CONT'D)

**TABLE 9 – POWER PANEL COMPONENTS - YCWS0313, YCWS0373, YCWS0423 AND YCWS0503**  
(SEE FIGS. 15, 15A AND 15B, PAGES 31-33)

ITEM NO.	QTY	DESCRIPTION	YCWS0313 -50 371-02788-00x	YCWS0373 -50 371-02788-01x	YCWS0423 -50 371-02788-02x	YCWS0503 -50 371-02788-03x
1A	2	Compressor Contactor (System 1)	024-31636-000	024-31636-000	024-31640-000	024-31640-000
1B	1		024-31636-000	024-31636-000	024-31636-000	024-31636-000
1A	2	Compressor Contactor (System 2)	024-31636-000	024-31640-000	024-31640-000	024-31603-000
1B	1		024-31636-000	024-31636-000	024-31636-000	024-31636-000
1C	6	Surge Suppressor	031-02203-000	031-02203-000	031-02203-000	031-02203-000
1D	1	Mechanical Interlock	024-31601-000	024-31601-000	024-31601-000	024-31601-000
	1		024-31601-000	025-31601-000	025-31601-000	024-31601-000
1G	2	Motor Protector	024-30907-000	024-30907-000	024-30907-000	024-30907-000
1K	2	Ground Lug, Cu	025-34088-000	025-34088-000	025-34088-000	025-34088-000
2A	3	Terminal Block (Sys1)	025-34482-000	025-34482-000	025-34482-000	025-34482-000
	3	Terminal Block (Sys2)	025-34482-000	025-34482-000	025-34482-000	025-34454-000
	1	Circuit Breaker (Sys1)	024-31843-000	024-31843-000	024-31649-000	024-31649-000
	1	Circuit Breaker (Sys2)	024-31843-000	024-31649-000	024-31649-000	024-31851-000*
	1	NF Disc. Switch (Sys1)	n/a	024-31888-000	024-31888-000	024-31888-000
	1	NF Disc. Switch (Sys2)	n/a	024-31888-000	024-31888-000	024-31888-000
	3	Fuse Block (Sys1)	025-37609-000	025-37609-000	025-37610-000	025-37610-000
	3	Fuse Block (Sys2)	025-37609-000	025-37609-000	025-37610-000	025-37610-000
2B	3	Fuse	025-37684-000	025-37684-000	025-37697-000	025-37697-000
	3		025-37684-000	025-37684-000	025-37697-000	025-37686-000
2C	2	Handle & Shaft (CB or NFDS)	024-31878-000	024-31878-000	024-31878-000	024-31878-000
2F	2	Ground Lug	025-34088-000	025-34088-000	025-34088-000	025-34088-000
2K	2	Auxiliary C/B Switch	024-31646-000	024-31646-000	024-31646-000	024-31646-000

\* Circuit Breakers 024-31819-000 and 024-31851-000 use (2F) Lug Kit 025-34089-000

**TABLE 9 – POWER PANEL COMPONENTS - YCWS0563, YCWS0613 AND YCWS0663**  
(SEE FIGS. 15, 15A AND 15B, PAGES 31-33)

ITEM NO.	QTY	DESCRIPTION	YCWS0563 -50 371-02788-04x	YCWS0613 -50 371-02788-05x	YCWS0663 -50 371-02788-06x
1A	2	Compressor Contactor (System 1)	024-31603-000	024-31603-000	024-31639-000
1B	1		024-31636-000	024-31636-000	024-31636-000
1A	2	Compressor Contactor (System 2)	024-31603-000	024-31603-000	024-31639-000
1B	1		024-31636-000	024-31636-000	024-31636-000
1C	6	Surge Suppressor	031-02203-000	031-02203-000	031-02203-000
1D	1	Mechanical Interlock	024-31601-000	024-31601-000	024-31601-000
	1		024-31601-000	025-31601-000	025-31601-000
1G	2	Motor Protector	024-30907-000	024-30907-000	024-30907-000
1K	2	Ground Lug, Cu	025-34088-000	025-34088-000	025-34088-000
2A	3	Terminal Block (Sys1)	025-34454-000	025-34454-000	025-34454-000
	3	Terminal Block (Sys2)	025-34454-000	025-34454-000	025-34454-000
	1	Circuit Breaker (Sys1)	024-31851-000*	024-31851-000*	024-31819-000*
	1	Circuit Breaker (Sys2)	024-31851-000*	024-31819-000*	024-31819-000*
	1	NF Disc. Switch (Sys1)	024-31888-000	024-31888-000	024-31870-000
	1	NF Disc. Switch (Sys2)	024-31888-000	024-31888-000	024-31870-000
	3	Fuse Block (Sys1)	025-37610-000	025-37610-000	025-37610-000
	3	Fuse Block (Sys2)	025-37610-000	025-37610-000	025-37610-000
2B	6	Fuse	025-37686-000	025-37686-000	025-37686-000
2C	2	Handle & Shaft (CB or NFDS)	024-31878-000	024-31878-000	024-31878-000
2F	2	Ground Lug	025-34088-000	025-34088-000	025-34088-000
2K	2	Auxiliary C/B Switch	024-31646-000	024-31646-000	024-31646-000

\* Circuit Breakers 024-31819-000 and 024-31851-000 use (2F) Lug Kit 025-34089-000

## TRANSDUCER AND THERMISTOR WIRE HARNESS CONNECTORS - FIELD REPLACEMENT PART NUMBERS

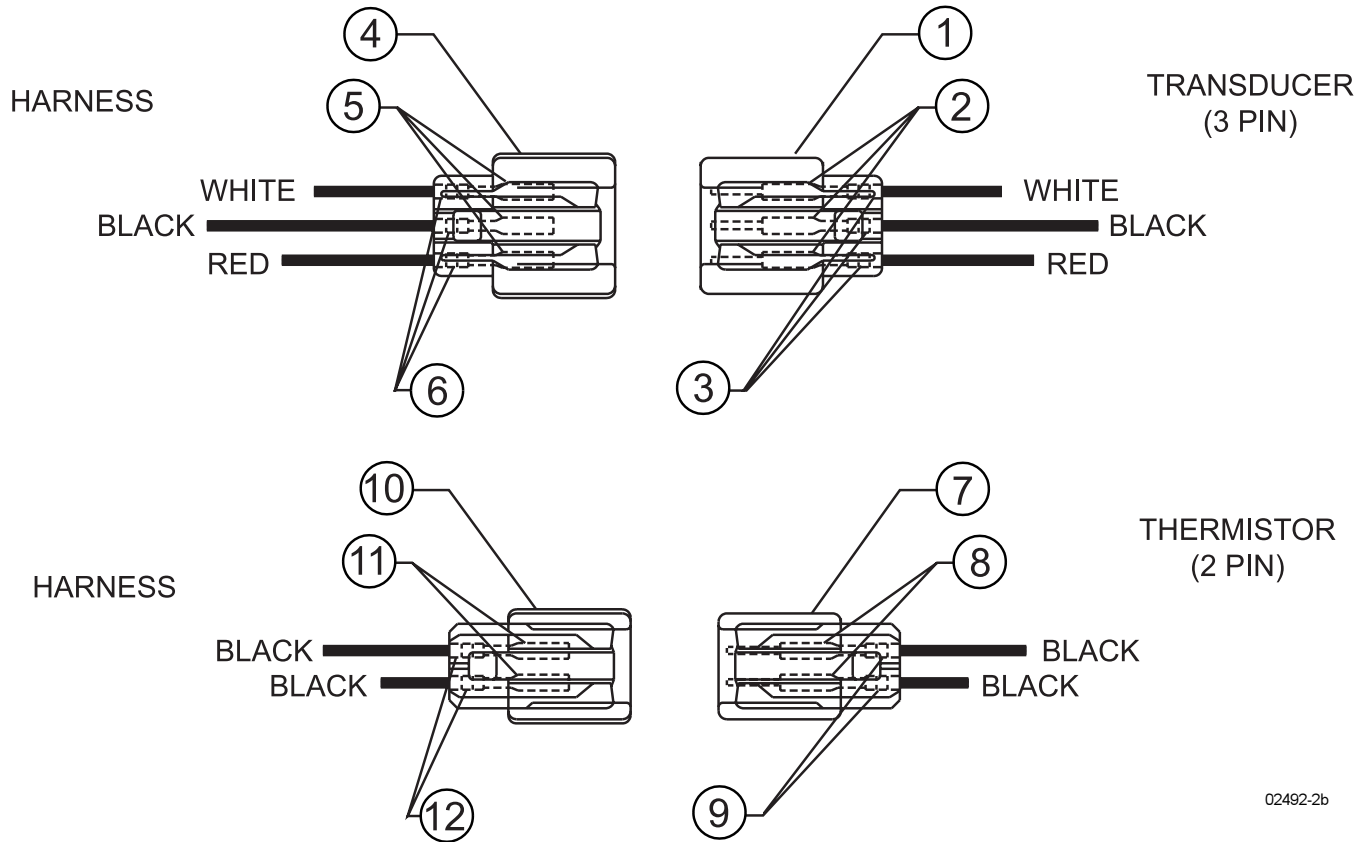

02492-2b

**FIG. 16 – TRANSDUCER AND THERMISTOR WIRE HARNESS CONNECTORS - FIELD REPLACEMENT PART NUMBERS (REF. TABLE 10)**

**TABLE 10 – TRANSDUCER AND THERMISTOR WIRE HARNESS CONNECTORS - FIELD REPLACEMENT PART NUMBERS (SEE FIG. 16)**

ITEM NO.	LOCATION	DESCRIPTION	PINS	PART NUMBER
1	Transducer	Plug Connector	3 Pin End	025-28953-000
2		Contact Pins		025-28949-000
3		Rubber Collar		025-28950-000
4	Wire Harness	Plug Connector	3 Pin End	025-28954-000
5		Contact Pins		025-28952-000
6		Rubber Collar		025-28950-000
7	Thermistor	Plug Connector	2 Pin End	025-28948-000
8		Contact Pins		025-28949-000
9		Rubber Collar		025-28950-000
10	Wire Harness	Plug Connector	2 Pin End	025-28951-000
11		Contact Pins		025-28952-000
12		Rubber Collar		025-28950-000

## TRANSDUCERS, PRESSURE CUTOUTS AND TEMP SENSORS

TABLE 11 – TRANSDUCER, PRESSURE CUTOUTS AND TEMP SENSORS - YCWS0100, YCWS0120, YCRS0100 AND YCRS0120 (SEE FIG. 17)

ITEM NUMBER	QUANTITY	SYSTEM	DESCRIPTION	VOLTAGE CODE	PART NUMBER
19 <sup>s</sup>	2	1 and 2	Sensor, Discharge Temperature	ALL	025-32924-000
21 <sup>s</sup>	2	1 and 2	Transducer, Suct. Press. (0-200psi)	ALL	025-29139-002
22 <sup>s</sup>	4	1 and 2	Transducer, Disch. Press. (0-400psi)	ALL	025-29139-001
24	4	1 and 2	Valve, Transducer	ALL	022-09503-000
26	2	1 and 2	Valve, Stop (1/4" x 1/4" NPTE)	ALL	022-00009-000
29	2	1 and 2	Valve, Discharge Stop - 1 5/8" (YCWS0313 & YCWS0373)	ALL	022-03727-003
30	2	1 and 2	Transducer, Oil Press. (0-400psi)	ALL	025-29139-001
31	2	1 and 2	Sensor, Oil Temperature	ALL	025-32924-000
32	2	1 and 2	Valve, Suction Stop (2 5/8" I.D.)	ALL	022-09777-001
38	2	1 and 2	Switch, High Pressure Cutout, 300 psi	ALL	025-35948-000

<sup>s</sup> Recommended Spare Part

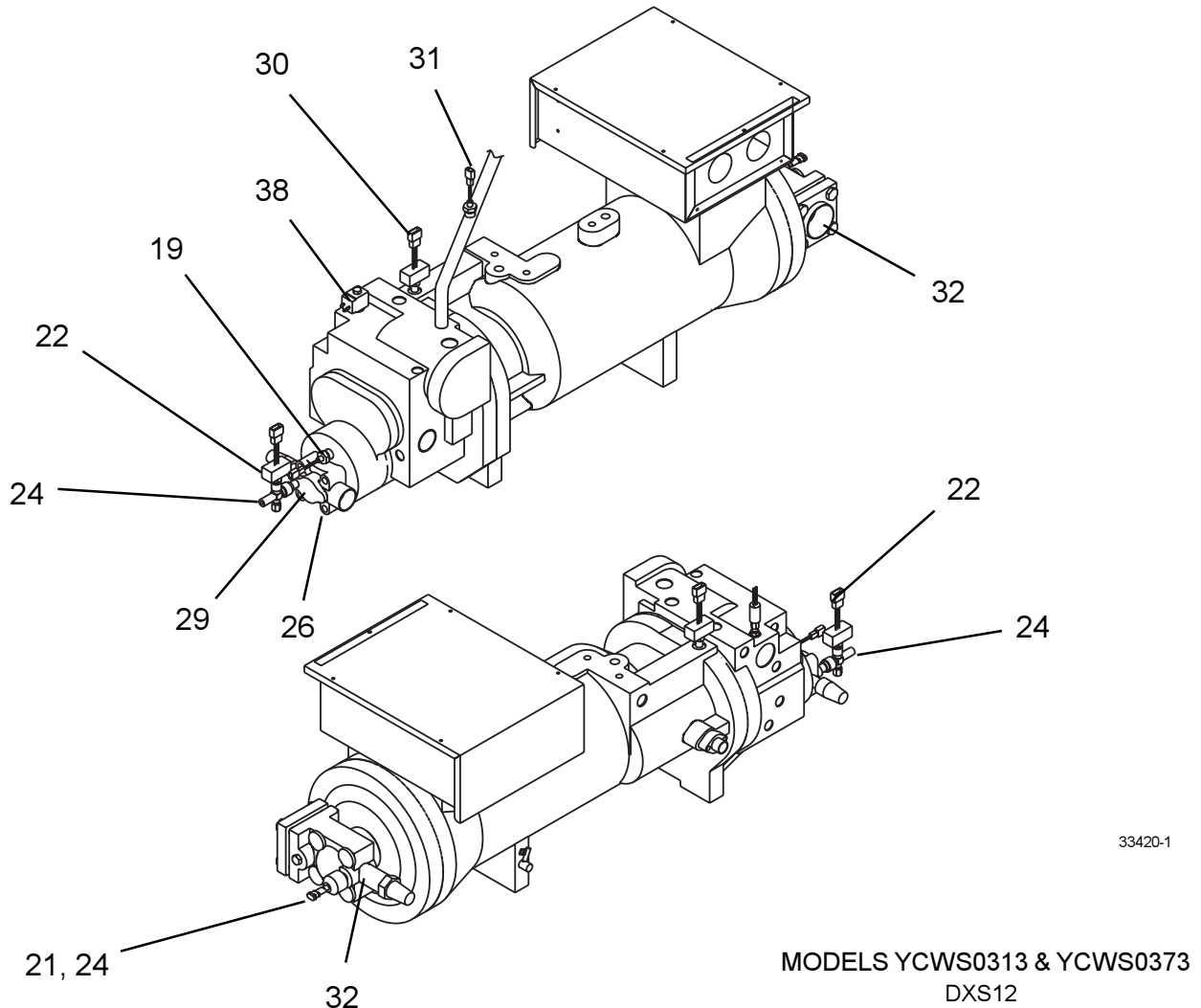

FIG. 17 – TRANSDUCERS, PRESSURE CUTOUTS AND TEMP SENSORS (REF. TABLE 11)

## TRANSDUCERS, PRESSURE CUTOUTS AND TEMP SENSORS (CONT'D)

TABLE 11a – TRANSDUCER, PRESSURE CUTOUTS AND TEMP SENSORS - YCWS0140 THRU YCWS0240, AND YCRS0140 THRU YCRS0240 (SEE FIG. 17A)

ITEM NUMBER	QUANTITY	SYSTEM	DESCRIPTION	VOLTAGE CODE	PART NUMBER
19 <sup>s</sup>	2	1 and 2	Sensor, Discharge Temperature	ALL	025-32924-000
21 <sup>s</sup>	2	1 and 2	Transducer, Suct. Press. (0-200psi)	ALL	025-29139-002
22 <sup>s</sup>	4	1 and 2	Transducer, Disch. Press. (0-400psi)	ALL	025-29139-001
24	4	1 and 2	Valve, Transducer	ALL	022-09503-000
26	2	1 and 2	Valve, Stop (1/4" x 1/4" NPTE)	ALL	022-00009-000
29	2	1 and 2	Valve, Discharge Stop - 2 1/8" (YCWS0423)	ALL	022-01393-001
	1	1 and 2	Valve, Discharge Stop - 3 5/8" (YCWS0503)	ALL	022-02845-001
	1		Valve, Discharge Stop - 2 1/8"		022-01393-001
	2	1 and 2	Valve, Discharge Stop - 3 5/8" (YCWS0573, YCWS0613 & YCWS0663)	ALL	022-02845-001
30	2	1 and 2	Transducer, Oil Press. (0-400psi)	ALL	025-29139-001
31	2	1 and 2	Sensor, Oil Temperature	ALL	025-32924-000
32	2	1 and 2	Valve, Suction Stop (2 5/8" I.D.)	ALL	022-09777-001
38	2	1 and 2	Switch, High Pressure Cutout, 300 psi	ALL	025-35948-000

<sup>s</sup> Recommended Spare Part

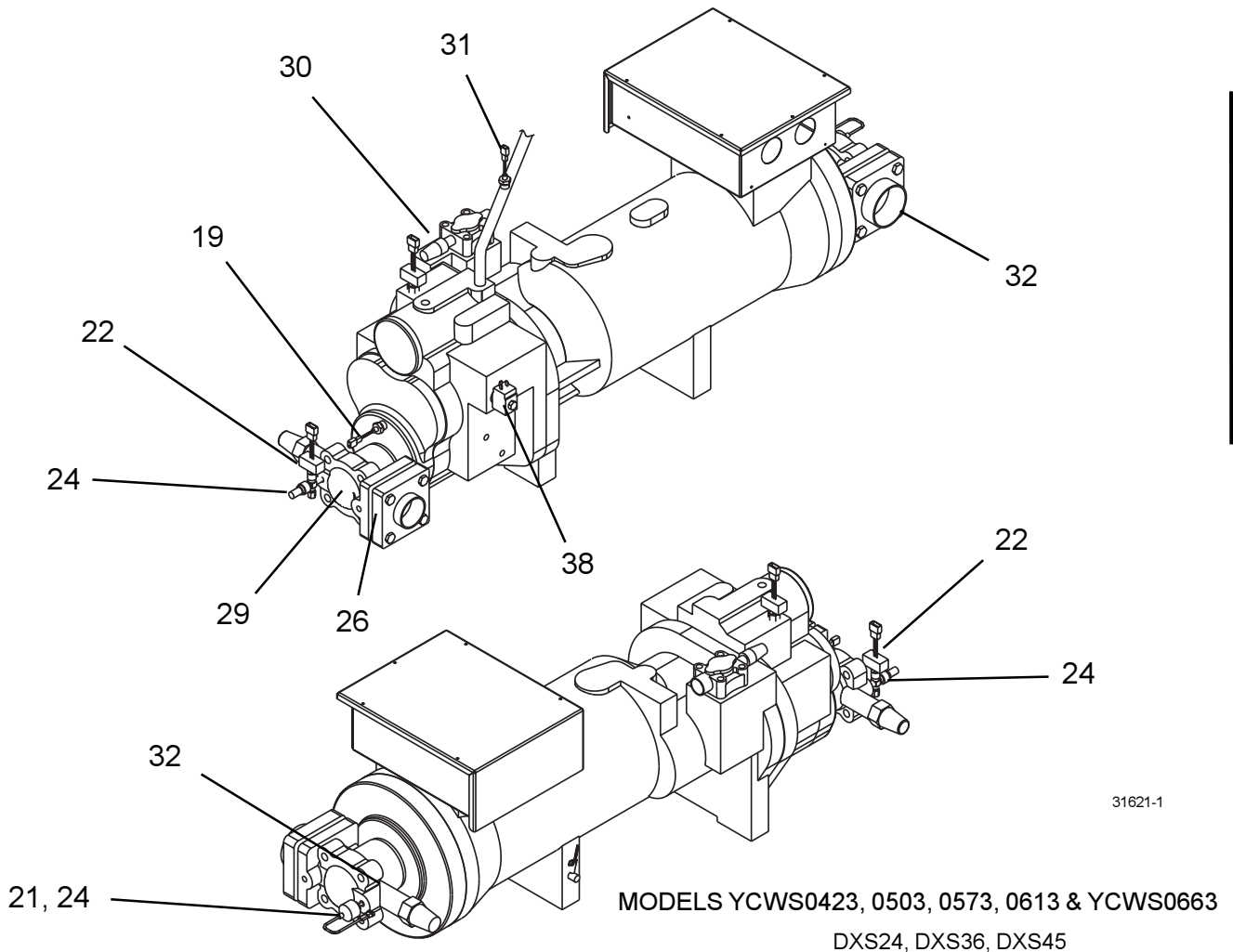

FIG. 17a – TRANSDUCERS, PRESSURE CUTOUTS AND TEMP SENSORS (REF. TABLE 11A)

## YCWS CHILLER OPTIONS – KITS

**TABLE 12 – FIELD INSTALLABLE OPTIONS TABLE**

<b>MODEL NUMBER YCWS</b>	<b>VIBRATION ISOLATORS SPRING 1" DEFLEC 50 HERTZ</b>	<b>VIBRATION ISOLATOR PAD 1/2" DEFLEC NEOPRENE 50 HERTZ</b>	<b>WELD FLANGE KIT (50 HERTZ)</b>	<b>VICTAULIC FLANGE KIT (50 HERTZ)</b>	<b>FLOW SWITCH (10 bar)</b>
<b>MODEL #</b>	029-	029-	375-	375-	024-
<b>0313</b>	22779-005	23711-000	41689-000	41670-001	26116-000
<b>0373</b>	22779-016	23711-000	41690-000	41670-002	26116-000
<b>0423</b>	22779-016	23711-000	41690-000	41670-002	26116-000
<b>0503</b>	23710-000	23712-000	41691-000	41670-003	26116-000
<b>0563</b>	23710-000	23712-000	41691-000	41670-003	26116-000
<b>0613</b>	20889-004	23712-000	41692-000	41670-004	26116-000
<b>0663</b>	20889-004	23712-000	41692-000	41670-004	26116-000

## YCWS CHILLER OPTIONS – KITS (CONT'D)

**TABLE 12 (CONT'D) – FIELD INSTALLABLE OPTIONS TABLE**

<b>MODEL NUMBER YCWS</b>	<b>HAND HELD PRINTER KIT (50 Hz)</b>	<b>BAS/EMS TEMP RESET / OFFSET</b>	<b>BAS/EMS CURRENT RESET / OFFSET</b>	<b>PRESSURE DIFFERENTIAL SWITCH</b>
<b>MODEL #</b>	375-44640	371-02336	371-02336	025-
<b>0313</b>	-000	-102	-101	30919-000
<b>0373</b>	-000	-102	-101	30919-000
<b>0423</b>	-000	-102	-101	30919-000
<b>0503</b>	-000	-102	-101	30919-000
<b>0563</b>	-000	-102	-101	30919-000
<b>0613</b>	-000	-102	-101	30919-000
<b>0663</b>	-000	-102	-101	30919-000

## REMOTE CONTROL CENTER

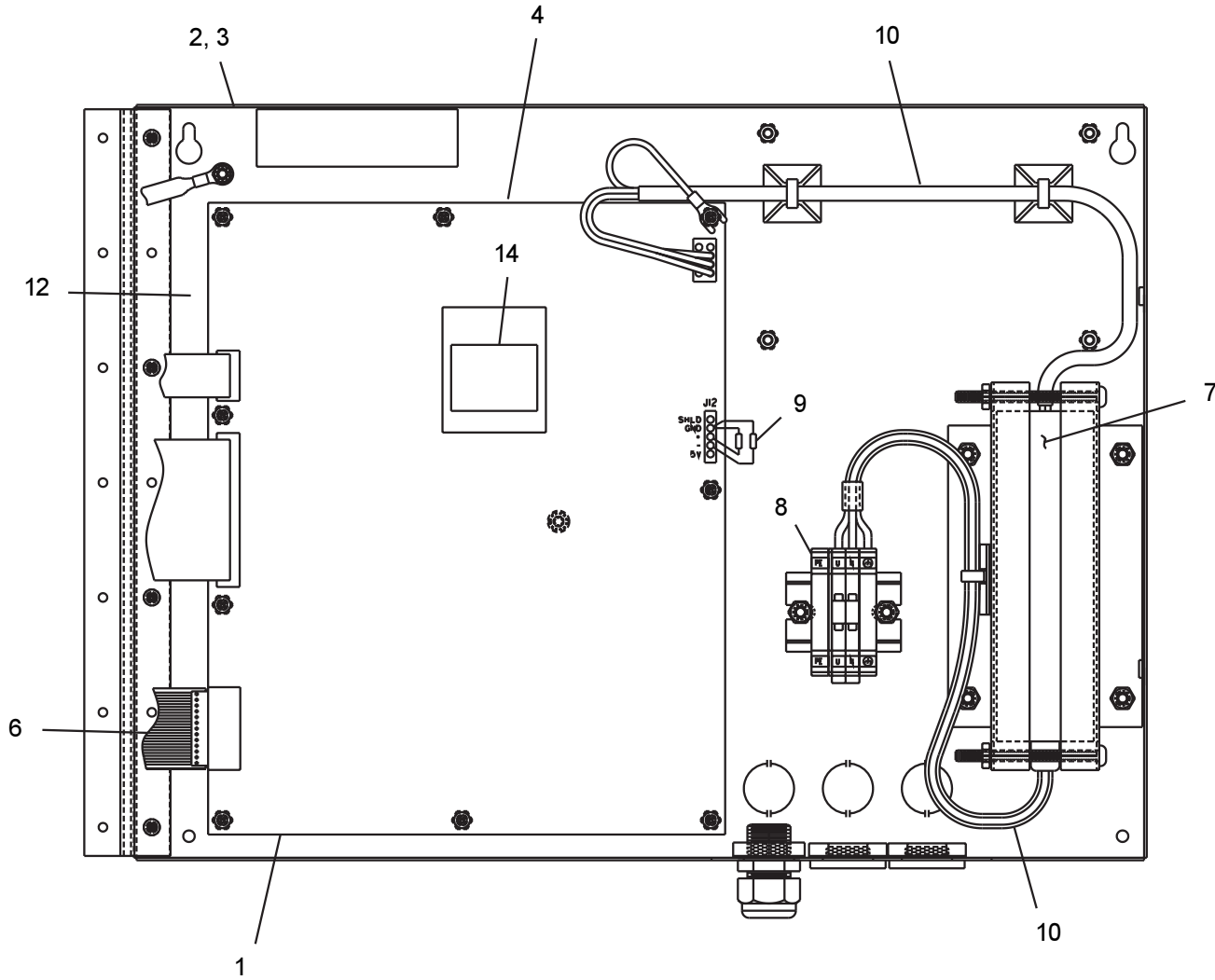

FIG. 18 – OPTI-VIEW REMOTE CONTROL PANEL

02750-3a

TABLE 13 – OPTI-VIEW REMOTE CONTROL PANEL PARTS

371-02750-101 (50 HZ)			
REF. NUMBER	QUANTITY	DESCRIPTION	PART NUMBER
1	1	CONTROL, MICROBOARD	031-01730-002
2	1	COVER, REMOTE CONTROL	371-02750-311
3	1	BASE, REMOTE CONTROL	071-02485-320
4	1	DISPLAY, KIT	331-02053-000
5	1	SWITCH, KEYPAD (NOT SHOWN)	024-30974-001
6	1	RIBBON CABLE	031-02056-000
7	1	POWER SUPPLY	371-02750-411
8	1	TERMINAL BLOCK	025-35120-000
9	1	SUPPRESSOR	031-02076-000
10	1	CABLE ASSEMBLY	571-02750-421
11	8	MODULE, LAN TRANSIENT PROTECTION (LTP)	031-01586-000
12	1	WIRING DIAGRAM	035-17188-000
13	1	OPERATOR'S MANUAL (NOT SHOWN)	201.24-NM1
14	1	FLASH MINI-CARD	031-02057-001

## REMOTE CURRENT/TEMPERATURE RESET PARTS BREAKDOWN

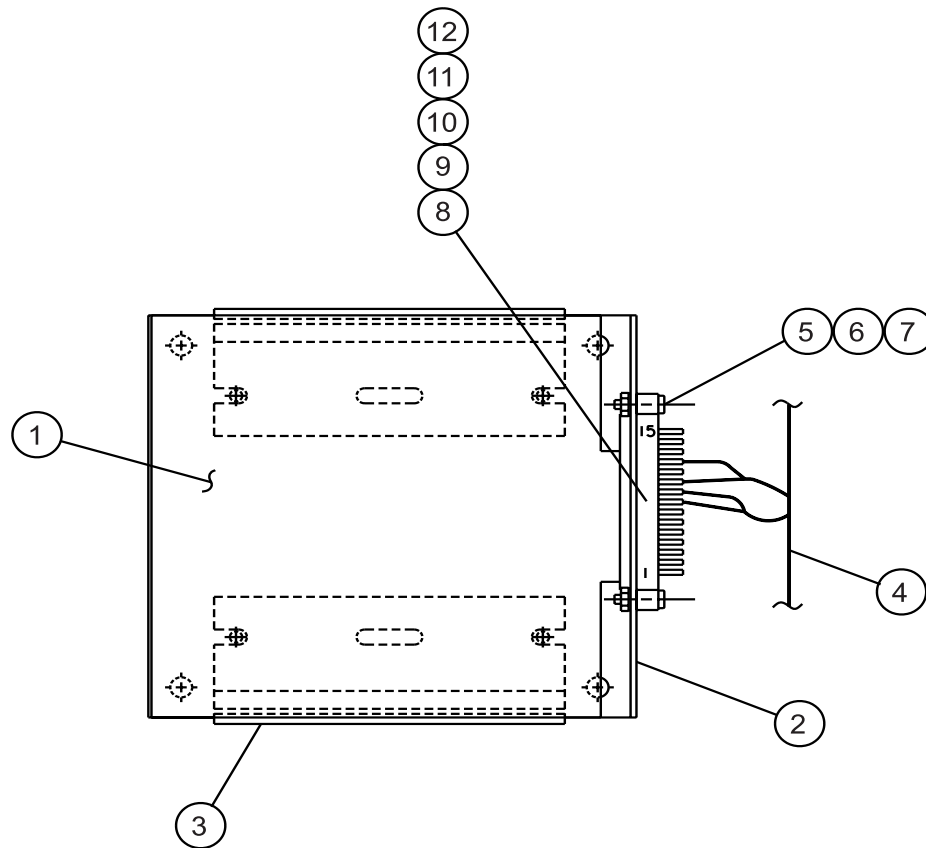

LD05256

**FIG. 19 – REMOTE CURRENT/TEMPERATURE RESET COMPONENTS**

**TABLE 14 – REMOTE CURRENT OR TEMPERATURE RESET KIT NUMBER 375-90914-000**

REF. NUMBER	QUANTITY	DESCRIPTION	PART NUMBER
1	1	CONTROL, REMOTE CURRENT/TEMP	031-00814-000
2	1	BRACKET, REMOTE CURRENT/TEMP RESET	371-01232-361
3	1	TRACK, SNAP	071-01232-363
4	1	WIRING, REMOTE CURRENT/TEMP RESET	571-02492-231*
5	2	SCREW, MACHINE PAN HEAD #4	021-17594-000
6	2	NUT, HEX MACH SCREW #4 – 40 UNC-2B	021-10056-000
7	2	LOCKWASHER, HEL. SPG. #4 REG.	021-17576-000

\* refer to Table 15

**TABLE 15 – REMOTE RESET WIRING**

REF. NUMBER	QUANTITY	DESCRIPTION	PART NUMBER
8	2	CONT SOC AWG WIRE SIZE 20	025-19674-000
9	2	TERMINAL PUSH ON STRAIGHT	025-06642-000
10	4	TUBING HEAT SHRINKABLE 1/8 ID	025-29632-000
11	1	HGS CONNECTOR ELECTRICAL PLUG	025-32564-000*
12	1	CONNECTOR EDGE, 15 POSITION, 0.125	025-29631-000

\* Was P/N 025-21137-000 prior to Spring 2000.

**RECOMMENDED SPARE PARTS**  
**York Model YCWS Style SC Water Cooled Liquid Chillers**  
**Suggested Spare Parts List for Critical Duty Applications**

**TABLE 16 – RECOMMENDED SPARE PARTS - YCWS CHILLERS (50 Hz)**

<b>PAGE REF. &amp; ITEM NUMBER</b>	<b>DESCRIPTION</b>	<b>MODEL NUMBER YCWS</b>	<b>PART NUMBER</b>
Page 5, Item <b>9</b>	Sensor, Water Temp.	All	025-29964-000
Page 10 & 11, Item <b>1</b>	Valve, Thermal Expansion (Evaporator)	All	See Table 3
Page 10 & 11, Item <b>3</b>	Core, Dehydrator	All	See Table 3
Page 10 & 11, Item <b>4</b>	Valve, Solenoid, Liquid Line	All	See Table 3
Page 14, Item <b>Oil</b>	Oil, Type "F" Compressor (5 gal.)	All	011-00434-000
Page 27, Item <b>4A</b>	Micro Board	All	031-01095-002
Page 27, Item <b>4B</b>	EPROM	All	031-01798-001
Page 27, Item <b>4C</b>	I/O Expansion Board	All	031-01781-000
Page 27, Item <b>4D</b>	Power Supply Board	All	031-01094-000
Page 36 & 37, Item <b>19</b>	Sensor, Discharge Temp.	All	025-32924-000
Page 36 & 37, Item <b>21</b>	Transducer, Suction Pressure	All	025-29583-000
Page 36 & 37, Item <b>22</b>	Transducer, Discharge Pressure	All	025-29139-001
Page 36 & 37, Item <b>24</b>	Valve, Transducer	All	022-09503-000
Page 36 & 37, Item <b>26</b>	Valve, Stop	All	See Table 9 & 10
Page 36 & 37, Item <b>29</b>	Valve, Stop	All	See Table 9 & 10
Page 36 & 37, Item <b>32</b>	Valve, Angle Stop	All	See Table 9 & 10
Page 36 & 37, Item <b>38</b>	Switch, High Pressure Cutout	All	025-35948-000

All parts should be purchased from your local  
YORK Sales And Service Center.

# NOTES



P.O. Box 1592, York, Pennsylvania USA 17405-1592  
Copyright © by York International Corporation 2002

Tele. 800-861-1001  
[www.york.com](http://www.york.com)

Subject to change without notice. Printed in USA  
ALL RIGHTS RESERVED

Form 201.24-RP2 (303)  
New Release