



THERMAX



ProChillTM **B4k**

Steam Fired Vapor Absorption Chiller



▶ Contents

- Company Profile 3
- Introduction 5
- Certificates 9
- Working Principle 11
- Design Philosophy 13
- Refrigeration Cycles 15
- Constructional Features and Mechanical Design Considerations 19
- Supply List and Scope of Work 21
- Utility Requirements 24
- Selection Criteria and Procedure 26
- Thermax Nomenclature and the Product Basket 27
- Performance Data 28
- Piping & Instrumentation Diagram & General Arrangement Drawing 31
- Instrumentation and Safety Features 33
- Machine Room Layout Considerations 37
- Site Unloading and Installation 39

► Company Profile

Thermax is an engineering major providing energy-environment solutions, systems and products in global markets. The US\$ 490 million Thermax is featured in the Forbes List of 'Best Under a Billion' Companies in the Asia Pacific. It offers business - to - business solutions to industrial and commercial establishments in the areas of heating, cooling, captive power, water treatment, air pollution control, waste management & resource recovery, and chemicals. It supports a wide spectrum of industry in over 50 countries in South East Asia and Japan, Africa and Middle East, CIS countries, South America, Europe and the USA.

In the energy business, Thermax executes projects in the areas of process heat, captive power and waste heat recovery. The company also offers a range of boilers and thermal oil heaters, energy efficient chillers and customized products such as waste heat and exhaust gas boilers. Thermax's integrated expertise in energy has helped it to offer its customers Combined Heating Power and Cooling (CHPC) projects.

Thermax offers industry its expertise over a hundred fuels - oil, gas and a wide variety of solid fuels including biomass. Through diverse installations in several countries, Thermax has also developed reliable project





management capabilities.

Leveraging its leadership position in electricity saving vapor absorption technology, Thermax offers process industries and commercial establishments like hotels, shopping malls and offices the vapor absorption chillers - a boon in power-starved areas. These eco-friendly, energy efficient equipments have found prestigious customers such as BBC, Mercedes Benz, Audi, Bosch, Panasonic and Henry Ford Museum.

In the environment area, Thermax offers waste management expertise for solid, liquid and air pollution. Thermax provides solutions from pre-treatment to waste water treatment and chemical conditioning of water for boiler and cooling water systems. Water recycling is a thrust area for Thermax. Hi-grade ion exchange resins from Thermax have found niche customers in the US and Japanese markets.

Thermax has an extensive international marketing network. Headquartered in Pune (Western India), Thermax's 17 international offices are located in South East Asia, Middle East, Africa, Russia, the UK and the US. Its overseas subsidiaries - Thermax Europe Ltd.

(UK), Thermax Hongkong Ltd. and Thermax Inc. (USA) play a significant role in business development.

The Thermax group's manufacturing facilities spread over 14 plants, measuring a covered area of over 700,000 sq. ft., are ISO 9001, ISO 14001 and OHSAS 18001 accredited. Thermax manufactures to the international standards like ASME, BS, DIN, and GOST. Lloyds, Bureau Veritas, SGS, and TUV have inspected the facilities.

Thermax's business is inspired by the conviction that 'Improving your business is our business.'



➤ Introduction



Refrigeration is a process of extracting heat from a low temperature medium and transferring it to a high temperature heat sink. Refrigeration maintains the temperature of the heat source below that of its surroundings while transferring the extracted heat to a heat sink. This operation finds applications in many industries ranging from process, engineering, manufacturing, medical, dairy and confectionery, to beverage, hospitality, education and commercial establishments.

Absorption chillers, instead of using electricity (i.e. high grade energy), use 'heat' as the energy source, a low grade energy. The energy source may be steam or hot water, or it may even be waste heat like in exhaust gases from an engine (gas or oil based). Thermax offers a wide range of solutions for each of these energy sources, all of which represent a major advance in Absorption Chilling Technology.

ProChill B4k Vapor Absorption Chillers derive their energy from steam to provide the desired chilling-heating effect.

These steam fired ProChill B4k Vapor Absorption Chillers are available in Single Effect and Double Effect options, from 100 - 2030 USRT, and can achieve chilled water temperature right down to 38°F, using steam from 21 to 145 psi (g).

The ProChill B4k Series represents a culmination of Thermax's global expertise in energy and environment, continuous innovation through focused Research and Development, world-class manufacturing capabilities, efficient and responsive service and a deep commitment to quality and reliability. Testimony to this is provided by over 2500 installations in the last 15 years across 40 countries, appreciation from our customers and several prestigious awards and honors.

Salient features of

- Series flow** (for Double Effect): In series flow cycle, maximum concentration and maximum temperature do not occur simultaneously in any generator. In other cycles, maximum concentration and maximum temperature occur simultaneously in the High Temperature Generator (HTG). Corrosion rates depend on concentration and temperature. However, when highest concentration and temperature occur simultaneously, corrosion potential increases exponentially. The table below gives approximate values of concentration and temperature in High Temperature Generator (HTG) and Low Temperature Generator (LTG) for various cycles.

Cycle	High Temperature Generator		Low Temperature Generator	
	Concentration (%)	Temperature (°F)	Concentration (%)	Temperature (°F)
Series flow	61	< 320	64	< 212
Para flow	64 or more	> 320	61- 62	< 212
Reverse flow	64 or more	> 320	61- 62	< 212

Thus, due to series flow cycle, the corrosion rate is the least in Thermax chillers.

- Concentration display and measurement:** Concentration in absorption chiller is analogous to current in electric motor. Motor meets higher load by drawing more current. Similarly, absorption chiller meets higher load by attaining higher concentration. However, when motor draws current more than it's rated limits, it may burn. Similarly, in an absorption chiller, if concentration increases beyond rated value,

the machine crystallizes. Hence, continuously knowing the Lithium Bromide concentration is as important as knowing the current drawn by motor. Thermax has developed and offers a unique technology to determine the **concentration, which is continuously displayed on the PLC.**

- **Crystallization protection:** Due to the unique feature of determining concentration and knowing temperature of Lithium Bromide coming out from Low Temperature Heat Exchanger (LTHE), an **intelligent PLC** constantly **monitors the distance from crystallization line.** If this distance is reduced below 18 °F, the PLC proactively takes suitable measures to restore it to 18 °F. In other machines, crystallization prevention measures are taken after inception of crystallization. However, due to advanced technology and intelligent panel, Thermax chillers take suitable measures before Lithium Bromide approaches crystallization.
- **Low Cooling Water Supply Temperature without crystallization:** Due to sophisticated crystallization protection, Thermax absorption chillers can work at rated capacity even with cooling water supply temperature of 50°F while most of the other manufacturers require cooling water supply temperature of 68°F or above.
- B4k machines use **SS430 Ti Ferritic Stainless Steel tubes** in the High Temperature Generator, for high temperature environment and high stress corrosion resistance. These tubes have a **long life** and, in case, if any tube has to be changed, it can be **individually removed and replaced.** In replacing/ plugging conventional U-tube bundles or floating tube sheet construction, the entire generator gets exposed to the atmosphere for a long time, thereby reducing chiller's life.



- **Long Life:** For a capital equipment like Absorption Chiller, life expectancy is 20 years. Thermax Absorption Chillers are carefully **designed for long life.** For example, for **maintaining the required pump NPSH**, height of the chiller is never compromised. If NPSH is not maintained, life of the pump will be reduced. After many years of service, some parts like heat exchangers, pumps may require repair/replacement. During the repair/replacement, minimum cutting should be required so that exposure of the chiller internals to air will be limited thereby arresting corrosion. Hence, all **parts are deliberately kept accessible** for increased life of the chiller. If chiller is made over compact, initially some space advantage can be derived but such advantage will be lost to life reduction later. The picture below (rear side of chiller) shows easy access to Low Temperature Heat Exchanger (LTHE), Drain Heat Exchanger (DHE), High Temperature Heat Exchanger (HTHE), and Pump.

NPSH (R) maintained

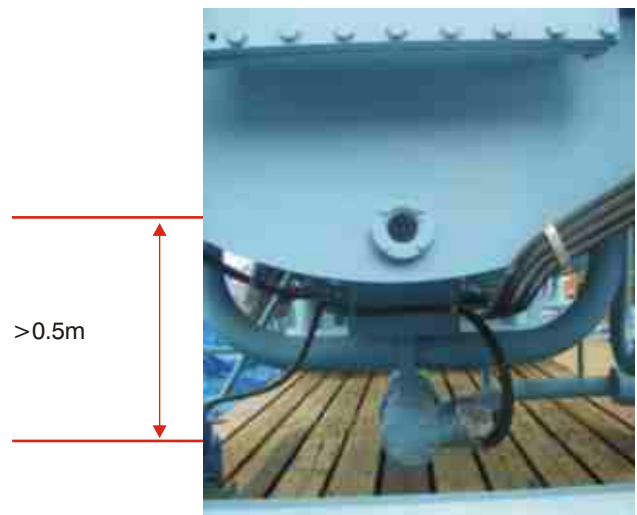

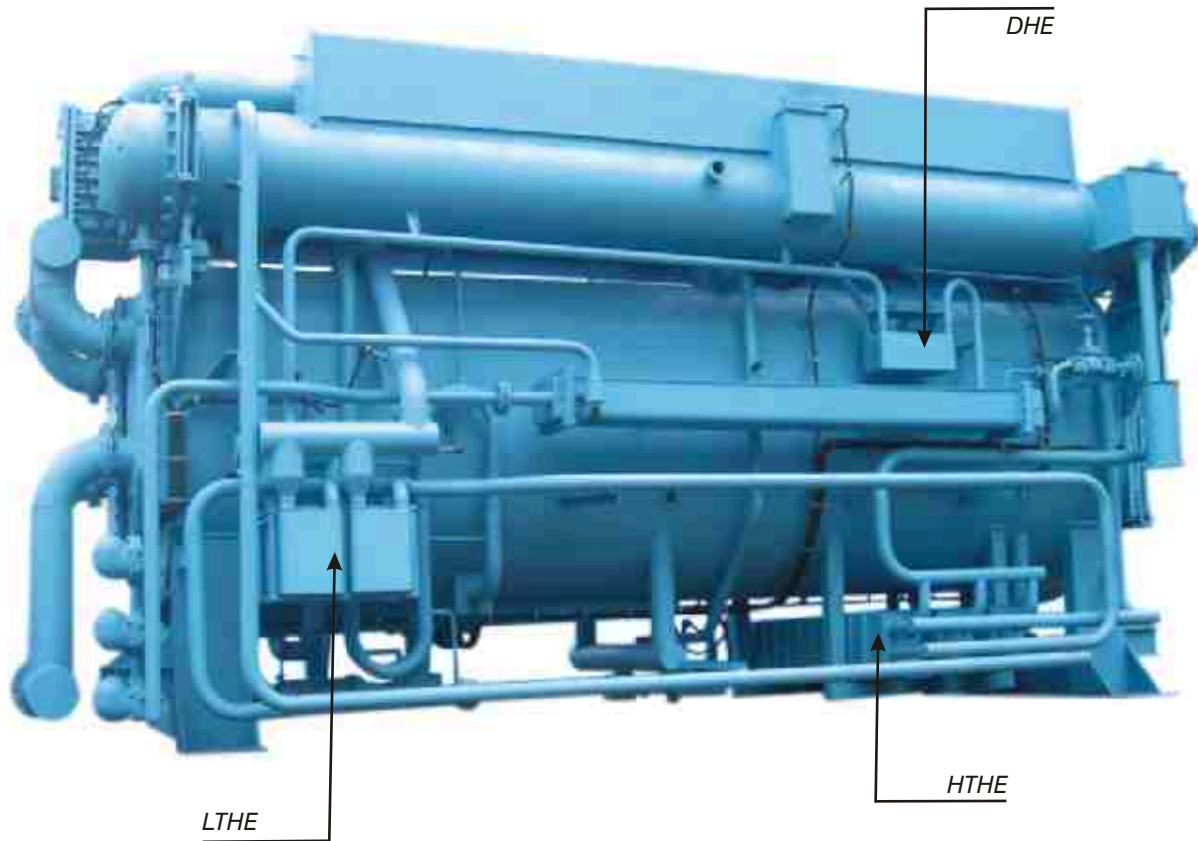

Easy access to all parts of the chiller

- **Isolation valves** are provided on the pumps, facilitating on-line pump maintenance without any loss of vacuum in the system due to the exposure to air.
- **Double protection**, in terms of differential pressure switch and flow switch, is provided for freeze protection.
- **Part load operation:** At constant cooling water temperature, the machine can operate at 10 - 100 % of design capacity, in step-less modulation.
- **Thermally efficient cycle:** Efficient heat utilization within the system reduces energy consumption and improves overall system efficiency. Specific steam consumption for Thermax's standard double effect B4k chiller is 8.6 lb/TR/hr and that for standard single effect machine is 16.8 lb/TR/hr. High COP chiller with specific steam consumption as low as 8.2 lb/TR/hr can also be offered on special requests.
- **Gravity feed system:** Gravity feed of refrigerant and absorbent enhances heat transfer efficiency and overcomes the problems of wear and tear and clogging of nozzles, which use pressurized spraying techniques.
- **PLC based control** panel, user-friendly interface and data-logging system ensure easy and smooth operations. Branded PLC enhances reliability of the chiller.
- **Effective corrosion inhibitors:** The corrosion inhibitor minimizes the rate of copper and ferrous metal corrosion on the solution side of the unit. The corrosion inhibitor used - Lithium Molybdate - is non-toxic and does not generate ammonia, thus protecting the copper tubes in the chiller. Use of Lithium Molybdate is more effective than conventionally used corrosion inhibitors.

- Factory mounted **on-line purging system** maintains low vacuum in the shell and ensures consistent performance. Any non-condensable gas, generated inside the chiller during operation, is purged continuously into the storage tank, thus eliminating the need for a replaceable palladium cell. Moreover, as peak concentration and temperature do not occur simultaneously, corrosion rates are low, thereby enabling a small purge tank.
- **Rupture disc** is provided for protection against generation of high pressure inside the chiller.
- **Constructional features**, such as side exit nozzles, provide ease of maintenance and ensure lower downtime. Hinged absorber and condenser headers provide easy access to the tube bundle, eliminating the need for heavy lifting arrangements. Crossover piping is factory installed, to avoid work at site.
- **Optional features** include VFD control for part load conditions, standby canned motor pumps, flameproof construction, high pressure headers, online bearing monitoring, special tube material for Evaporator, Absorber and Condenser, depending on the available water quality, multi-sectional shipment and 'Factory Performance Test'.
- **Service:** A global network, powered by over 100 highly trained service personnel, ensures quick response and delivers the right solution to customers. Also on offer are value-added services such as 'e-reach' - remote access for chillers, preventive maintenance contracts, operations and manning and localized customer training programs.



➤ Certificates





► Working Principle

The boiling point of water is directly proportional to pressure. At atmospheric pressure, water boils at 212°F. At a lower pressure, it boils at a lower temperature. At 0.24 inch Hg absolute pressure, the boiling point of water is 39°F.

To change water from liquid to vapor it has to be heated. The water absorbs the applied heat and its temperature starts rising, until it reaches the boiling point. At boiling point, the temperature remains constant but liquid water vaporizes. The heat required to change the phase of a liquid to vapor is called the 'Latent heat of Vaporization'. Similarly the heat rejected by the vapors during

condensation is called the 'Latent Heat of Condensation'.

For the LiBr - water system, the absorption varies directly in proportion with the solution concentration and inversely with the solution temperature. Lithium Bromide (LiBr) is a water soluble chemical, and LiBr - water solution (used as refrigerant) has an inherent property to absorb water due to its chemical affinity.

Also, there is a huge difference between vapor pressure of LiBr and water. This means that when the LiBr water solution is heated, the water will vaporize but LiBr will stay in the solution to become more concentrated.

Absorption Cycle Overview:

1

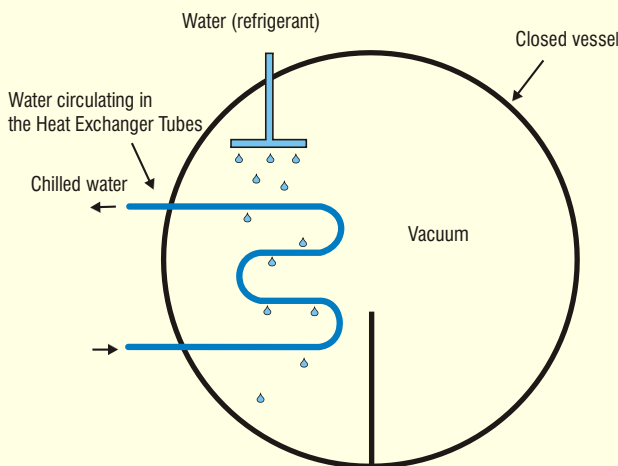

When maintained at high vacuum, water will boil and flash cool itself.

Absorption systems use heat energy to produce the refrigerating effect. In these systems the refrigerant, i.e. water, absorbs heat at a low temperature and low pressure during evaporation and releases heat at a high temperature and high pressure during condensation.

2

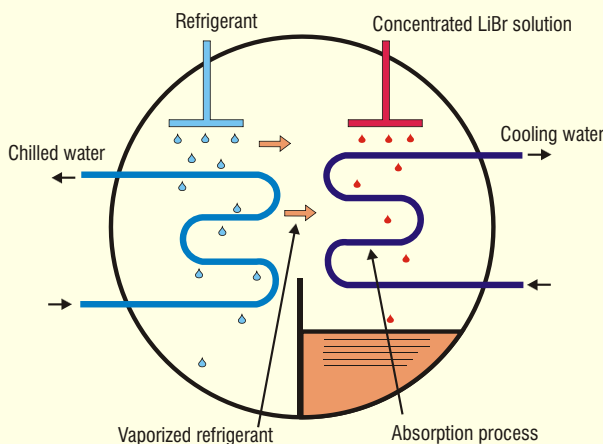

Concentrated Lithium Bromide solution has affinity towards water. The solution absorbs vaporized refrigerant water.

LiBr solution, which acts as the absorbent, is used to absorb the vaporized refrigerant. The evaporation of the refrigerant takes place at a low pressure.

3

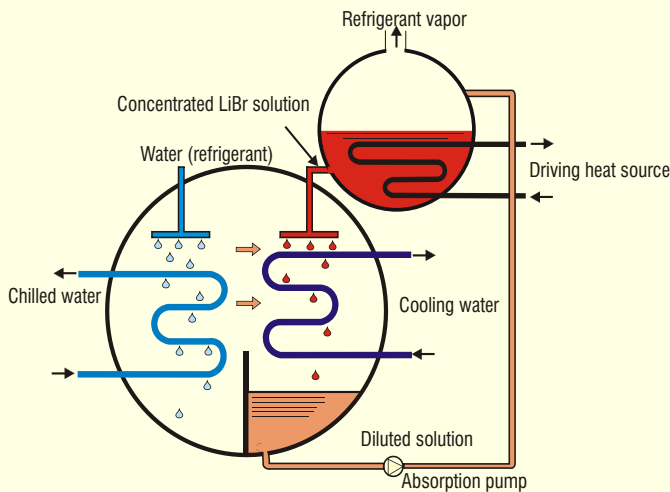

As Lithium Bromide becomes dilute it loses its capacity to absorb water vapor. It thus needs to be reconcentrated using a heat source.

The dilute solution, which contains the absorbed refrigerant vapor, is heated at a higher pressure.

4

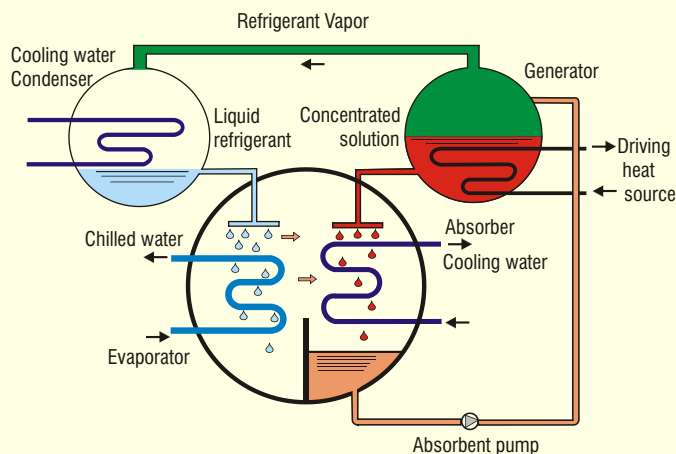

This heat causes the solution to release the absorbed refrigerant in vapor form. This vapor is cooled in a separate chamber to become liquid refrigerant.

This leads to the vaporization of the refrigerant and thus the solution is restored to its original concentration. The cycle keeps repeating itself to give the desired chilling effect. In a double effect absorption chiller, the latent heat of condensation, contained in the vaporized refrigerant, is used in a second stage generator to enhance the efficiency of the cycle.

5

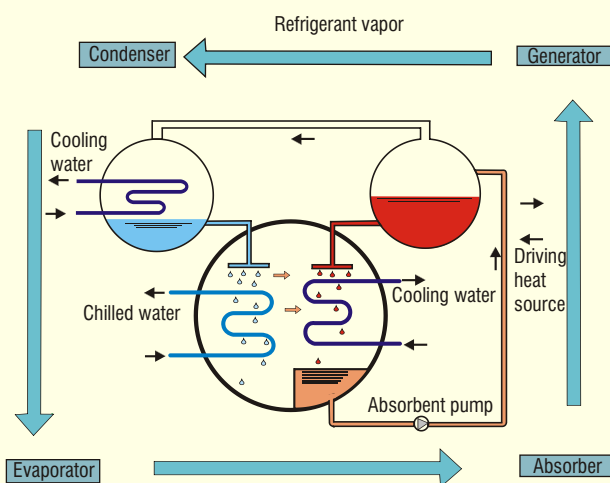

The basic operation cycle of the single effect vapor absorption chiller.

The refrigerant goes through a series of processes to complete the refrigerating cycle. These are namely evaporation, absorption, pressurization, vaporization, condensation, throttling and expansion. During this cycle, the refrigerant absorbs heat from a low temperature heat source and releases it to a high temperature sink.

► Design Philosophy

The design philosophy of Thermax Absorption Chillers is based on three important factors viz. reliability, energy consumption and ease of maintenance.

Reliability: While designing absorption chillers, two major problems have to be considered viz. corrosion and crystallization. Since corrosion is caused by temperature, concentration and leakages of Lithium Bromide, Thermax has carefully selected the Series Flow Cycle (after manufacturing Series Flow, Parallel Flow and Reverse Flow Chillers) so that the highest temperature of Lithium Bromide is limited to less than 320°F and maximum concentration is limited to 64%. A detailed comparison as tabulated on page 5 coupled with the features like Crystallization Protection and Concentration measurement and display, clearly shows that Thermax Chillers are reliable compared to the other Chillers.

In the series flow cycle, crystallization can occur only in the Low Temperature Heat Exchanger, whereas in other cycles it can happen in both, the High Temperature and Low Temperature Heat Exchangers. It was discovered during the research, that the time taken to de-crystallize High Temperature Heat Exchanger was 10 times more than that taken to de-crystallize the Low Temperature Heat Exchanger. To eliminate the possibility of crystallization in the Low Temperature Heat Exchanger, the distance of state point from crystallization curve is continuously monitored, and if the distance is less than the prescribed value, crystallization control takes over and performs suitable actions to prevent crystallization.

The normal method of sensing the high concentration from generator temperature has a flaw - it fails to work when it is most required. It is a well-known fact that the possibility of crystallization is more when the cooling water temperatures are low. At low cooling water temperatures, the generator pressure lowers and the boiling point curve shifts down. Thus, when the cooling water temperatures are low, the boiling temperature of Lithium Bromide does not reach the high temperature set point and becomes ineffective protection, even if high concentration is reached. When cooling water temperatures are normal, it works well but the possibility of crystallization is far less. Monitoring the distance from the crystallization line eliminates such flaws, enabling Thermax to design chillers which can even work at 50°F cooling water temperature.

Coefficient of Performance (COP): Today, Thermax chillers offer one of the best COPs.

Ease of maintenance: This is an important aspect of our design philosophy. Even after 5 years of use, absorption chillers require some small maintenance. So, if ease of maintenance is ignored in the design philosophy, this small maintenance can turn into big maintenance. In addition to the design features listed on pages 5 and 6, illustrated below are some more design features in Thermax chillers that play a role in making maintenance easy.

- **Double sealed valves:** All isolating valves and service valves have a double seal. More importantly, the outer seal has no moving parts.
- **Use of branded components:** The Thermax philosophy makes it mandatory to use branded components. Some examples are PLC and Low Temperature Heat Exchangers. This is because while Thermax conducts exhaustive reliability tests on self made components, it still cannot match the years of research and experience put in by internationally reputed PLC or Plate Heat Exchanger manufacturers.

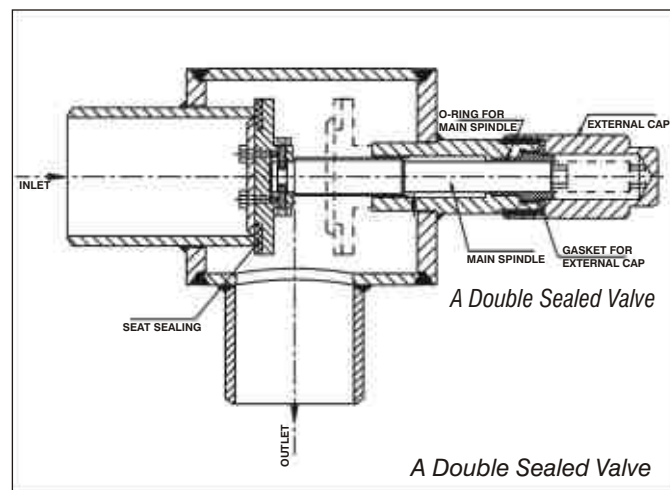

- **CANNED Motor Pump:** In Thermax Absorption Chillers, these pumps are in bolted construction (except for 20 frame, small chillers) so that if required, bearing and filters can be cleaned after few years of operation. In case of welded pumps, replacement of the entire pump is the only solution.



Bolted CANNED Motor Pump



Welded CANNED Motor Pump

What is a CANNED Motor Pump?

CANNED motor pump is some times misinterpreted as a pump similar to hermetically sealed compressor of a window air-conditioner.

CANNED motor pump is a single unit of a pump and a motor, and has no shaft seal. Shaft seal is a moving joint and cannot pass through stringent helium leak test.

In the CANNED motor pump, the pumped liquid is used for cooling motor as well as lubrication of bearings. Hence, the pumped liquid enters the motor section, and in order to keep the liquid away from the motor coil and the rotor, the motor coil and the rotor are sealed with CANS, which are thin metal cylinders.

Bolted canned motor pump, bit costly though, offer advantage like replacement of parts, which may be needed after many years of service. Only non-moving parts are bolted and hence they offer excellent leak proof properties while offering maintainability simultaneously.

➤ Refrigeration Cycle

The Steam Fired Vapor Absorption Chiller functions in the Cooling mode. Depending on the available steam pressure, the refrigeration cycle could be either single or double effect.

Single effect

Evaporator

The Evaporator consists of a tube bundle, an outer shell, distribution trays and a refrigerant pan.

A refrigerant pump is used to circulate the refrigerant from the refrigerant pan to the distribution trays. From these trays, the refrigerant falls on to the evaporator tubes.

The evaporator shell pressure is maintained at ~ 0.24 inch Hg (a). At this low pressure, the refrigerant evaporates at a low temperature of $\sim 39^\circ\text{F}$ (for its evaporation, the refrigerant extracts the required heat from the water which is circulated through the evaporator tubes). As a result, the water in the tubes becomes chilled.

Absorber

The Absorber consists of a tube bundle, an outer shell (common with the Evaporator) and distribution trays.

The Generator is housed in the upper shell, just above the Absorber. From the Generator, a concentrated absorbent solution ($\sim 64\%$) is fed into the distribution trays, which falls on to the absorber tubes.

On the other hand, the vaporized refrigerant from the Evaporator is absorbed by the concentrated absorbent, leading to its dilution. Due to this absorption the vacuum in the shell is maintained at a low pressure, leading to the desired chilled water temperature. During this process, 'Heat of Dilution' is generated. The cooling water circulating through the absorber tubes removes this heat. As the absorbent solution loses its heat to the cooling water, it is able to absorb more refrigerant vapor and gets further diluted. This diluted absorbent ($\sim 58\%$) collects at the bottom of the shell.

Heat Exchanger

The absorbent pump sends the diluted absorbent to the Generator. It passes through a Regenerative Heat Exchanger, where it absorbs heat from the concentrated absorbent, before entering the Generator. Because the

Heat Exchanger heats up the cool absorbent solution before it enters the Generator for reheating, it reduces the heat input required in the Generator and increases the efficiency of the cycle.

Generator and Condenser

The Generator and Condenser tube bundles are enclosed in a shell and are separated by an insulation plate. Dry saturated steam flows into the Generator tubes, heats the absorbent, flows outside the tubes and, finally, condenses to drain out of the unit. Refrigerant, vaporized from the absorbent, passes through the Eliminators to the Condenser. Here, the cooling water, circulating inside the condenser tubes, cools it down. The refrigerant vapor condenses on the outside of the condenser tubes and collects at the bottom of the Condenser. The condensed refrigerant, from the Condenser, flows into the Evaporator. The absorbent, which has become concentrated in the Generator, drains into the Absorber through the Heat Exchanger, to begin a new absorbent cycle.

Single Effect Cycle

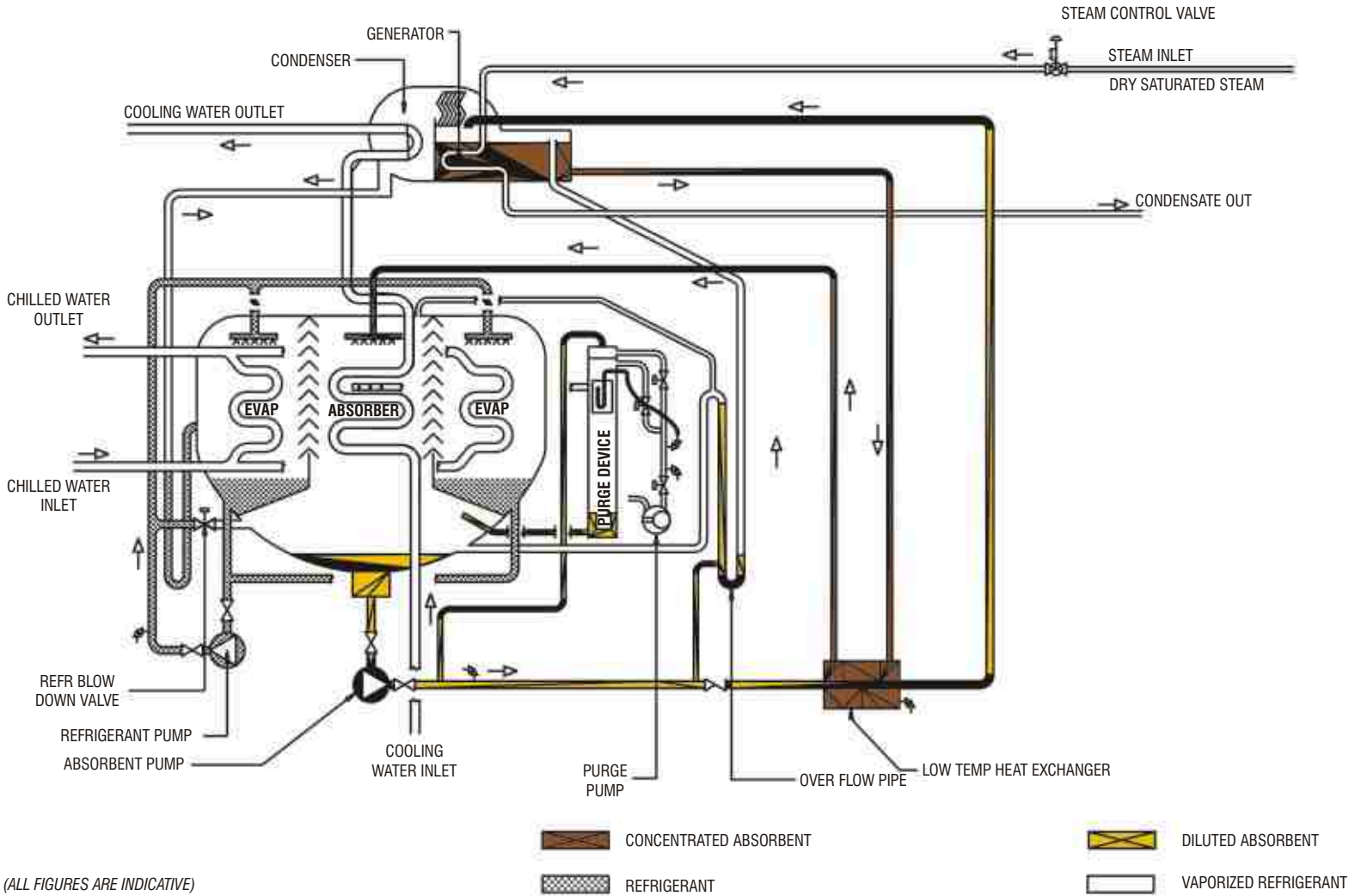

(ALL FIGURES ARE INDICATIVE)

Double Effect



The HTG, LTG, Condenser

Evaporator

The Evaporator consists of a tube bundle, an outer shell, distribution trays, and a refrigerant pan. A refrigerant pump is used to circulate the refrigerant from the refrigerant pan into the distribution trays. From these trays, the refrigerant falls on the evaporator tubes.

The Evaporator shell pressure is maintained at ~ 0.24 inch Hg (a). At this low pressure, the refrigerant evaporates at a low temperature of $\sim 39^\circ\text{F}$ (for its evaporation, the refrigerant extracts the required heat from the water which is circulated through the evaporator tubes). As a result, the water in the tubes becomes chilled.

Absorber

The Absorber consists of a tube bundle, an outer shell (common with the Evaporator) and distribution trays.

The Generator is housed in the upper shell, just above the Absorber. From the Generator, a concentrated absorbent solution ($\sim 64\%$) is fed into the distribution trays, which falls on to the absorber tubes.

On the other hand, the vaporized refrigerant from the Evaporator is absorbed by the concentrated absorbent, leading to its dilution. Due to this absorption, the vacuum in the shell is maintained at a low pressure, leading to the desired chilled water temperature. During this process, 'Heat of Dilution' is generated. The cooling water, circulating through the absorber tubes, removes this heat. As the absorbent solution loses its heat to the cooling water, it is able to absorb more refrigerant vapor and gets further diluted. This diluted absorbent ($\sim 58\%$) collects at the bottom of the shell.

Heat Exchangers

The absorbent pump sends the cool diluted absorbent to the High Temperature Generator. A part of it first passes through the Drain Heat Exchanger, where it absorbs heat from the condensed refrigerant in the Low Temperature Generator. It then flows through the Heat Reclaimer where it absorbs heat from the steam condensate. The other part of the absorbent solution passes through the Low Temperature Heat Exchanger, where it absorbs heat from the concentrated absorbent. It then flows through the High Temperature Heat Exchanger, where it absorbs heat from the intermediate concentration of absorbent solution. Both the dilute solutions mix at the outlet of the High Temperature Heat Exchanger. This solution then enters the High Temperature Generator. The Heat Exchangers serve to heat up the cool absorbent solution before its entry into the High Temperature Generator for regeneration. This reduces the heat input required in the High Temperature Generator, thus increasing the efficiency of the cycle.

High Temperature Generator (HTG)

The High Temperature Generator consists of a tube bundle, an outer shell and a set of Eliminators. Steam is passed through the tubes. The dilute absorbent flows around these tubes and heats up. The temperature of the solution increases until it reaches the boiling point. The absorbed refrigerant boils out of the solution. The solution concentration increases to $\sim 61\%$ and this increased concentration is referred to as the intermediate concentration. The vaporized refrigerant generated passes through the eliminators and goes to the tube side of the Low Temperature Generator.

Low Temperature Generator (LTG) and Condenser

The Low Temperature Generator and condenser tube bundle are enclosed in the upper shell, with an insulation plate separating the two. The vaporized refrigerant flows into the LTG tubes, where it heats the intermediate absorbent outside and, in the process, gets condensed. This condensed refrigerant flows to the condenser through the drain heat exchanger.

On the other hand, the refrigerant vaporized in the Low Temperature Generator, passes through the Eliminators to the Condenser. Cooling water circulates inside the condenser tubes. The refrigerant vapor condenses on the outside of the condenser tubes and collects at the bottom of the Condenser.

The condensed refrigerant from the LTG and from the Condenser, mix and then flow into the Evaporator. The absorbent, now concentrated in the LTG, flows to the Absorber, to begin a new absorbent cycle.

Double Effect Cycle

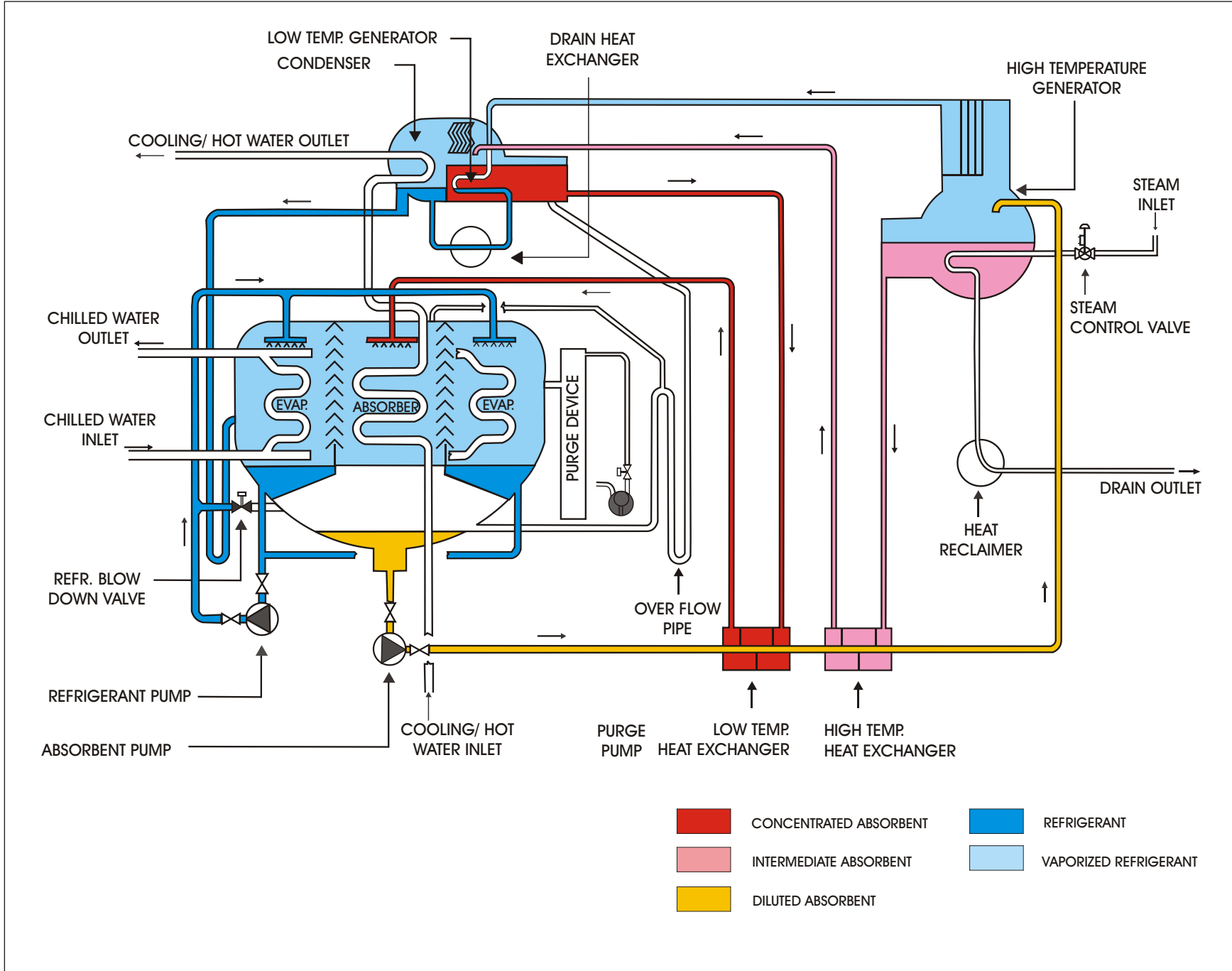

► Constructional Features And Mechanical Design Considerations

ProChill B4k chillers can be designed to conform to the codes and standards given below. Whenever no specific standard is applicable, the design is according to good and proven engineering standards.

- ISO 9001:2000 ■ ISO 14001 ■ ETL ■ CE ■ PED ■ TUV
- DNV ■ ASME ■ OHSAS 18001

The lower shell houses two shell and tube heat exchangers viz. the Absorber and Evaporator. This shell is fabricated from formed carbon steel plates with fusion welded seams. Carbon steel tube sheets are drilled and reamed to accommodate absorber and evaporator tubes, and the tube ends are expanded to ensure no leakages between the shell and tube side. The support plates inside the shell are also fabricated from carbon steel plates. Enhanced copper tubes are used in the Absorber and Evaporator. The maximum allowable working pressure on the tube side is 114 psi (g). Gravity feed spraying technology is applied to spray the solution in the Absorber and Evaporator. The solution in the spraying tubes sprays downward to ensure good film thickness and better heat transfer. The Absorber and Evaporator are separated by an Eliminator that prevents the carryover of LiBr from Absorber to Evaporator, while allowing the water vapor from Evaporator to cross over to the Absorber. The lower shell is mounted on the base frame.

In a single effect chiller, the upper shell comprises of the Generator and Condenser. This shell is also fabricated from carbon steel plates. Smooth copper tubes are used in the Condenser and finned stainless steel tubes in the Generator. Gravity feed spraying technology is applied to spray the solution in the Absorber and Evaporator. An Eliminator, that prevents the carryover of LiBr from the Generator to Condenser, separates these two. The upper shell rests on the lower shell.

Dry saturated steam passes through the tubes of the Generator.

In a double effect chiller, the upper shell comprises of the Low Temperature Generator and Condenser. This shell is also fabricated from carbon steel plates. Smooth copper tubes are used in the Condenser and finned carbon steel tubes in the Low Temperature Generator. An Eliminator, that prevents the carryover of LiBr from the Low

Temperature Generator to Condenser, separates the Low Temperature Generator and the Condenser. The upper shell rests on the lower shell.

The High Temperature Generator is a shell and a Tube Heat Exchanger with carbon steel tubes. Dry, saturated steam passes and condenses inside these tubes. The shell is fabricated from carbon steel.

The Regenerative and Recuperative Heat Exchangers increase the efficiency of the cycle by utilizing the heat within the system.

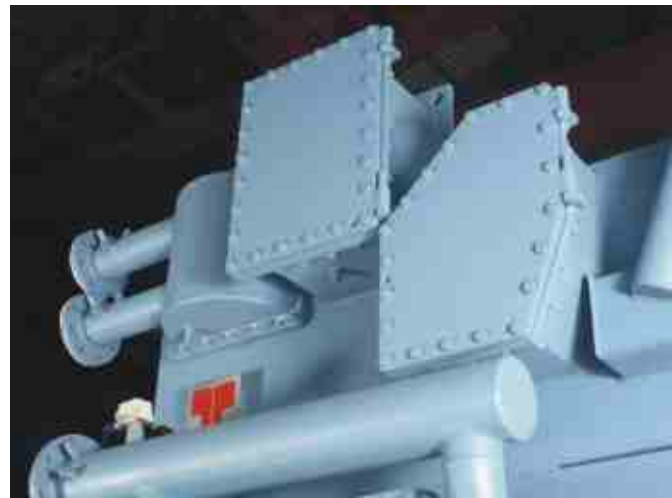

Marine type Headers

Marine type water boxes are connected to the Absorber and Condenser. These are provided with drain and vent connections to remove cooling water hold-up when the chiller is not in operation for a long time. These marine water boxes enable easy tube cleaning and replacement.



Canned Motor Pump

The absorbent and refrigerant pumps are factory mounted and are the canned motor type, where the motor is directly coupled to the pump. For ease of maintenance, the isolation valves are welded at the inlet and the outlet. These valves facilitate on-line pump maintenance without disturbing the vacuum. All valves used for adjusting the solution are fully welded to prevent leakage of air into the unit.

Non-condensable gases are removed from the chiller by operating the vacuum pump and the manual purge valves. Service valves are provided for N₂ charging, for sampling, and for connecting the Manometer.



Purge System

➤ Supply List And Scope Of Work

Single Effect

Sr.No.	Description	Remarks
A Lower Shell		
1.	Evaporator	Common Shell and Tube sheets, separate water boxes
2.	Absorber	
3.	Base Frame	
B Upper Shell		
4.	Generator	Common Shell and Tube sheets, separate water boxes
5.	Condenser	
C Heat Exchangers		
6.	Heat Exchanger	Plate Heat Exchanger(s)
D Pumps and Motors		
7.	Absorbent Pump and Motor	Canned Motor Pump Set
8.	Refrigerant Pump and Motor	Canned Motor Pump Set
9.	Purge Pump and Motor	Vacuum Pump Set
E	Purge System	For Separation of Non-condensable gases from Absorbent and its Storage.
F	Piping	Interconnecting Piping.
G	Instrumentation	Control Panel, Field Instruments, Cabling.
H	Electricals	Starters, Circuit breakers, Wiring within Battery Limits.
I	Documents	Operation and Maintenance Manual, Packing List.

Double Effect

Sr. No.	Description	Remarks
A	Lower Shell	
1.	Evaporator	Common Shell and Tube sheets, separate water boxes
2.	Absorber	
3.	Base Frame	
B	Upper Shell	
4.	Low Temperature Generator	Common Shell and Tube sheets, separate water boxes
5.	Condenser	
C	High Temperature Generator	High Temperature Generator with internals.
D	Heat Exchangers	
6.	Low Temperature Heat Exchanger	Plate Heat Exchanger
7.	High Temperature Heat Exchanger	Plate Heat Exchanger
8.	Drain Heat Exchanger	Plate Heat Exchanger
9.	Heat Reclaimer	Shell and Tube Heat Exchanger
E	Pumps and Motors	
10.	Absorbent Pump and Motor	Canned Motor Pump Set
11.	Refrigerant Pump and Motor	Canned Motor Pump Set
12.	Purge Pump and Motor	Vacuum Pump Set
F	Purge System	For Separation of Non-condensable gases from Absorbent and its Storage.
G	Piping	Interconnecting Piping.
H	Instrumentation	Control Panel, Field Instruments, Cabling
I	Electricals	Starters, Circuit breakers, Wiring within Battery Limits.
J	Documents	Operation and Maintenance Manual, Packing List.

Distribution of Scope of Work - Manufacturing, Transportation and Installation

Item / Activity	Thermax	Customer	Remarks
Chiller			
Chiller Manufacture with accessories	✓		Refer to Supply List.
Testing			
Factory Testing	✓		Thermax Optional Feature.
On-site Erection		✓	
Supervision of Commissioning	✓	✓	Customer to assist, Thermax Representative will supervise the commissioning.
Transportation			
Loading at Thermax Factory	✓		
Factory to Port	✓		
Port in India to Port of Destination*		✓	Optional.
Port to Job-site		✓	
Unloading at Job-site		✓	
Storage at Job-site		✓	If required.
Construction and Installation			
Handling at Job-site		✓	Rigging, Shifting to actual location.
Civil Foundation		✓	
Piping outside Battery Limits		✓	Refer to Supply List.
Chiller Insulation*		✓	
Piping Insulation outside Battery Limits		✓	Refer to Supply List.
Electrical Connections outside Battery Limits		✓	Refer to Supply List.
Assembly and On-site Connections		✓	For Multi-Sectional Shipment (Optional).
Butterfly valve in the cooling water line		✓	If required. (Refer to Safety Functions under Instrumentation and Safety Features.)
Operation and Maintenance			
Training of Customer's Operators during commissioning (maximum period of 7 days)	✓		
Operation		✓	

NOTE: * Indicates that the scope of supply can also be included by Thermax, as an option.

► Utility Requirements

Chilled Water: The chiller's design ensures the delivery of desired cooling capacity. The chilled water flow rate to the machine is kept constant. Hence its capacity is proportional to the difference in the temperatures of the inlet and the outlet chilled water.

Cooling Water: Cooling water is used to remove heat of absorption and condensation. The chiller can be designed to suit the rated cooling water temperature of 75 to 97° F.

Energy Source: The chiller is designed for steam at different pressures. Single Effect chillers require steam at a pressure of 56.9 psi (g), whereas Double Effect chillers require steam at a pressure of above 56.9 psi (g), going up to 142.2 psi (g).

Air: Compressed air is required for pneumatic operation of the control valve. The supplied air should be moisture free and the required pressure should be 100 psi (g).

Electricity: The power supply to the chiller shall be strictly according to the voltage and frequency ratings given on the chiller nameplate.

To avoid scaling and corrosion, we recommend maintaining water quality as given here. If the water quality at the installation site is different, the chiller can be designed to adjust to it.

Chilled Water and Cooling Water Treatment

Water treatment of the chilled and cooling water is important to get desired chiller performance and for its long life.

If the water quality is bad, it shows a scaling and/or corrosion tendency. As a result, sludge and scale can adhere to the inside of the tubes. This impedes heat transfer between the chilled water and refrigerant and between the cooling water and LiBr solution. Consequently, there can be an increase in the respective temperatures of the LiBr solution and the condensed refrigerant, leading to an increase in the fuel consumption and thus hampering the capacity and efficiency of the chiller. In cases of prolonged corrosion, the tubes will require maintenance or, in some cases, they may even have to be replaced.

As the cooling water circuit is open, the salts get concentrated due to evaporation taking place in the cooling tower. This can be adjusted by controlling cooling water blow-down and make-up. Moreover, exposure to sunlight favors biological growth. Slime is more detrimental to heat transfer than scale. Dosing bio-cides during cooling water treatment can minimize these adverse effects.

Unlike the cooling water circuit, which is always open, the chilled water circuit may be open or closed. Due to the lower temperature, chilled water circulating in an open circuit does not have severe consequences. Soft water is recommended for use in this circuit.

JIS recommends the following water quality for copper tubes:

Sr. No.	Description	Unit	Specifications	
			Chilled Water	Make-up Water
1	pH at 77°F		6.5 - 8.5	6.5 - 8.5
2	Electrical Conductivity (max.)	μs/cm	500	200
3	M Alkalinity (max.)	ppm	100	50
4	Total Hardness (max.)	mg CaCO ₃ /lit	100	50
5	Chloride ion (max.)	mg Cl/lit	100	50
6	Sulphate ion (max.)	mg SO ₄ /lit	100	50
7	Total Iron (max.)	mg Fe/lit	1	0.3
8	Sulphide ion	mg S/lit	Not detected	
9	Ammonium ion (max.)	mg NH ₄ /lit	0.5	0.2
10	Silica ion (max.)	mg SiO ₂ /lit	50	30
11	Free carbonic acid (max.)	mg CaCO ₃ /lit	10	-
12	Turbidity	NTU	10	5
13	BOD / COD (max.)	mg/lit	160	160

Sr. No.	Description	Unit	Specifications	
			Cooling Water	Make-up Water
1	pH at 77°F		6.5 - 8.5	6.5 - 8.5
2	Electrical Conductivity (max.)	μs/cm	800	200
3	M Alkalinity (max.)	ppm	100	50
4	Total Hardness (max.)	mg CaCO ₃ /lit	200	50
5	Chloride ion (max.)	mg Cl/lit	200	50
6	Sulphate ion (max.)	mg SO ₄ /lit	200	50
7	Total Iron (max.)	mg Fe/lit	1	0.3
8	Sulphide ion	mg S/lit	Not detected	
9	Ammonium ion (max.)	mg NH ₄ /lit	1	0.2
10	Silica ion (max.)	mg SiO ₂ /lit	50	30
11	Suspended solids (max.)	mg/lit	20	5
12	Turbidity	NTU	20	5
13	BOD / COD (max.)	mg/lit	160	160

➤ Selection Criteria And Procedure

Selection Criteria

The following factors govern model selection:

Energy Source Parameters: Once the energy source(s) is / are identified, parameters such as pressure, temperature and flow play an important role in the selection of the appropriate model. Single effect chillers have lower COP than double effect chillers. Rated steam pressure for single effect chiller is 21 psi (g). However, single effect chillers can be offered from 7psi (g) to 50 psi (g). While the capacity of the chiller is likely to reduce when steam pressure available is less than rated, the capacity will remain constant for higher steam pressures. Rated steam pressure for double effect chiller is 114 psi (g). However, double effect chillers can be offered for pressure of 57 psi (g) and above. At lower steam pressures, the chiller capacity is likely to reduce.

Chilled and cooling water temperature:

Capacity of the chiller varies based on chilled water outlet temperature and cooling water inlet temperature. The chiller is capable of delivering higher than its rated capacity if chilled water temperature is higher than the rated temperature or cooling water temperature is lower than the rated temperature. Conversely, the chiller capacity is likely to be reduced if chilled water temperature is lower and cooling water temperature is higher than their respective rated temperatures. Thermax has designed and installed chillers for chilled water temperatures ranging from 38°F to 70°F and cooling water temperatures varying from 50°F to 97°F.

Chilled and cooling water circuit pressure:

Thermax's standard product range is designed for a maximum pressure of 114 psi (g) in the chilled and cooling water circuits. Thermax also offers special design for higher pressures.

Size: For ease of operation, Thermax design ensures sufficient distance between various parts of the chiller. However, on special requirement, compact chiller can be manufactured to fit within the available space at the existing site. Moreover, if the openings available at site are smaller than the chiller size, the chiller can be transported in multiple sections and assembled at site.

Optional features: These include tube material of construction, frequency drive for double effect absorbent pumps, flame proof construction, claded tube sheets and special electronics and instrumentation.

Selection Procedure

Absorption is a complex phenomenon involving heat and mass transfer. The chiller consists of multiple interlinked heat exchangers. In such a complex mechanism, derivation factors and two-dimensional graphs can lead only to approximation. At Thermax, every selection is done with the help of a computer program that does detailed heat and mass transfer calculations for each heat exchanger and accurately determines performance of the chiller. When using media other than water or for non-standard fouling factors, the selection considers appropriate properties to evaluate overall heat transfer coefficient. The program optimizes the energy and the fuel consumption, the chilled and the cooling water flow rates and the pressure drops.

The following document furnishes performance data and the dimensional data for all the standard models.

► Thermax Nomenclature And The ProChill B4k Product Basket

SS20DC

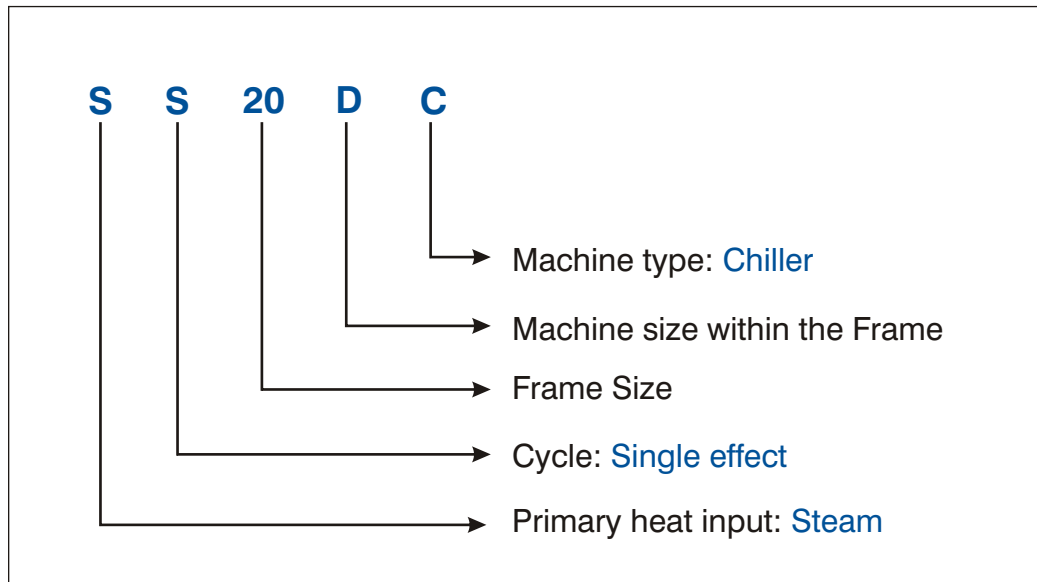

SD50ACX

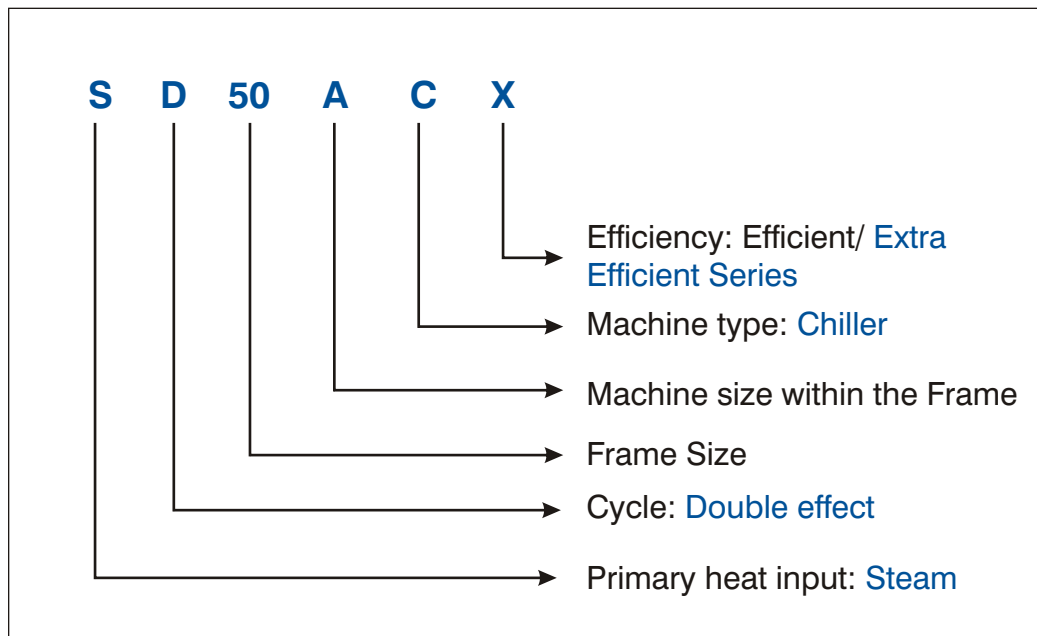



Performance Data

Single Effect Steam Fired

Model Number	UNITS	SS 20A C	SS 20B C	SS 20C C	SS 20D C	SS 30A C	SS 30B C	SS 30C C	SS 30A C	SS 30B C	SS 30C C	SS 40A C	SS 40B C	SS 40C C	SS 50A C	SS 50B C	SS 60A C	SS 60B C	SS 60C C	SS 60D C	SS 70A C	SS 70B C	SS 80A C	SS 80B C	SS 80C C	SS 80D SS
Cooling Capacity	TR	132	159	201	241	290	327	385	435	493	538	611	671	765	849	933	1036	1188	1311	1491	1641	1881	2029			
Flow rate	GPM	318.8	383.9	485.2	581.8	700.1	789.4	929.4	1050.1	1190.1	1298.8	1475.0	1619.8	1846.6	2049.5	2252.1	2500.8	2867.9	3164.9	3599.3	3961.7	4540.7	4898.2			
No. of passes (Evaporator)	#	2	2	2	2	2	2	2	2	2	2	2	2	2	2	2	2	2	2	2	2	2	2	2	2	
Friction loss	f _{WC}	8.2	10.8	23.0	28.9	21.3	23.6	14.1	8.5	10.2	11.5	8.5	9.5	11.2	12.1	18.7	20.3	20.3	21.7	17.1	18.7	29.2	30.8			
Connection Diameter	inchNB	5																								
Flow rate	GPM	467	564	709	850	1021	1154	1347	1497	1700	1845	2091	2281	2695	2994	3034	3381	3998	4262	5253	5781	6626	7150			
Outlet Temp	°F	101.5	101.6	101.4	101.5	101.4	101.4	101.7	101.8	101.8	102.0	101.8	102.0	101.8	101.4	102.9	102.7	102.2	102.7	101.4	101.3	101.4	101.4	101.4		
No. of passes (absorber)	#	3	3	2	2	2	2	2	2	2	2	2	2	2	2	2	2	2	2	2	2	2	2	2	2	
No. of passes (condensor)	#	2	2	1	1	1	1	1	1	1	1	1	1	1	1	1	1	1	1	1	1	1	1	1	1	
Friction loss	f _{WC}	19.0	19.7	17.1	18.7	15.1	15.7	23.3	20.7	21.3	21.7	22.6	23.3	27.9	28.5	39.7	41.0	40.7	41.7	37.7	41.3	28.5	30.2			
Connection Diameter	inchNB	6																								
Steam Consumption	lb/hr	2251	2727	3406	4107	4888	5531	6544	7305	8290	9136	10298	11376	12897	14306	15763	17559	19965	21997	25014	27485	31729	34046			
Connection Diameter (Steam)	inchNB	6																								
Connection Diameter (Drain)	inchNB	1.5																								
Length	inch	116.1	116.1	157.3	157.3	162.8	162.8	188.8	194.1	194.1	194.1	199.2	199.2	261.8	261.8	310.4	310.4	309.3	309.3	328.3	328.3	379.9	379.9			
Width	inch	74.0	74.0	74.0	74.0	87.0	87.0	87.0	92.3	92.3	92.3	92.3	92.3	101.2	101.2	105.3	105.3	112.6	112.6	132.3	132.3	132.3	132.3			
Height	inch	111.4	111.4	111.4	111.4	115.9	115.9	115.9	130.5	130.5	130.5	134.1	134.1	150.0	150.0	150.0	150.0	165.0	165.0	184.8	184.8	184.8	184.8			
Operating Weight	x 1000 lb	12.0	12.3	14.6	15.0	19.0	19.6	21.6	27.5	28.5	29.2	33.8	34.6	49.6	51.0	56.9	58.9	75.0	76.9	100.5	102.0	112.9	114.7			
Max. Shipping Weight	x 1000 lb	10.8	11.0	13.1	13.3	16.7	17.2	18.9	23.8	24.5	25.1	28.9	29.4	42.7	43.7	49.0	50.5	64.3	65.7	85.1	86.0	95.4	96.6			
Clearance for Tube Removal	inch	102.4	141.7	145.7	165.4	167.3	173.2	224.4	271.7	271.7	275.6	326.8														
Absorbent Pump Motor Rating	kW (A)	1.1 (3.4)	1.5 (5)	3 (8)	3.7 (11)	3.7 (11)	5.5 (14)	6.6 (17)	4.5 (13)	4.5 (13)	4.5 (13)	1.5 (5)														
Refrigerant Pump Motor Rating	kW (A)	0.3 (1.4)																								
Purge Pump Motor Rating	kW(A)	0.75 (1.8)																								
Total Electric Input	kVA	5.7	6.9	9.1	11.2	11.2	13.4	18.1	15.2	15.2	15.2	5.5 (17)														
Power Supply		460 V (±10%), 60 Hz (±5%), 3 Phase+N																								

- Notes:
- Chilled water inlet / outlet temperature = 54 / 44 °F
 - Cooling water inlet temperature = 85°F
 - Minimum Cooling water inlet temperature is 68°F
 - Steam at Control Valve Inlet is at 21.335 psi(g)
 - pressure in dry saturated condition.
 - Control panel Electric Input = 1 kVA
 - Maximum Allowable pressure in chilled / cooling water system = 113.78 psi(g)
 - Maximum Allowable pressure in steam system = 71.116 psi(g)
 - Ambient condition shall be between 41 to 113°F
 - All Water Nozzle connections to suit ASME B16.5 Class 150
 - Technical specification is based on ARI 560 : 2000

Double Effect Steam Fired



Model Number	UNITS																								
Cooling Capacity	TR	111	130	162	192	240	272	320	360	408	452	505	560	636	709	802	890	993	1107	1251	1372	1570	1685	SD 800 CX	
Flow rate	GPM	268.1	313.9	391.0	463.6	579.4	656.5	772.7	869.1	984.9	1091.0	1219.2	1351.7	1535.3	1711.4	1935.9	2148.6	2397.4	2672.5	3019.9	3312.3	3790.0	4067.8	SD 800 CX	
No. of passes (Evaporator)	#	3	3	2	2	2	2	2	2	2	2	2	2	2	2	2	2	2	2	2	2	2	2	SD 800 CX	
Friction loss	fWC	13.1	15.4	15.7	19.4	15.1	16.7	25.6	21.3	22.3	24.3	21.7	22.0	21.3	22.6	14.4	15.4	14.8	16.1	12.5	13.5	21.3	22.3	SD 800 CX	
Connection Diameter	inchNB	4				6				8				10				12							
Flow rate	GPM	488.7	572.4	713.3	845.4	1056.7	1197.6	1408.9	1563.0	1774.4	1990.1	2183.8	2426.0	2800.2	3121.6	3531.1	3918.6	4392.2	4887.2	5283.4	5723.7	6912.5	6956.5	SD 800 CX	
Outlet Temp	°F	94.5	94.5	94.5	94.5	94.5	94.5	94.5	94.6	94.5	94.5	94.6	94.6	94.5	94.5	94.5	94.5	94.4	94.4	94.8	95.0	94.5	95.0	SD 800 CX	
No. of passes (absorber)	#	3	3	2	2	2	2	2	2	2	2	2	2	2	2	1	1	2	1	2	2	1	1	SD 800 CX	
No. of passes (condensor)	#	1	1	1	1	1	1	1	1	1	1	1	1	1	1	1	1	1	1	1	1	1	1	SD 800 CX	
Friction loss	fWC	12.8	12.5	14.8	15.4	14.8	15.1	22.3	21.0	21.3	22.6	22.6	24.0	25.3	25.9	17.7	18.7	36.4	19.7	34.8	36.4	23.6	23.3	SD 800 CX	
Connection Diameter	inchNB	6				8				10				12				14				16			
Steam Consumption	lb/hr	953	1114	1388	1647	2049	2326	2737	3077	3488	3866	4321	4799	5415	6024	6873	7606	8484	9430	10645	11681	13396	14409	SD 800 CX	
Connection Diameter (Steam)	inchNB	2		2.5		3		3		3		3		4		4		5		5		5		SD 800 CX	
Connection Diameter (Drain)	inchNB	1																							
Length	inch	115.7	115.7	155.9	155.9	162.6	162.6	186.6	186.6	191.3	191.3	191.3	191.3	198.8	198.8	261.4	261.4	310.2	310.2	305.9	305.9	318.1	367.3	367.3	SD 800 CX
Width	inch	83.5	83.5	78.3	78.3	85.0	85.0	85.0	85.0	98.0	98.0	98.0	105.1	105.1	114.2	114.2	114.2	114.2	124.8	124.8	140.2	140.2	140.2	140.2	SD 800 CX
Height	inch	100.8	100.8	100.8	100.8	106.3	106.3	106.3	106.3	114.2	114.2	114.2	125.2	125.2	132.3	132.3	132.3	132.3	147.2	147.2	160.2	160.2	160.2	160.2	SD 800 CX
Operating Weight	x 1000 lb	12.3	12.8	15.2	15.9	20.9	21.6	23.6	28.9	30.0	31.3	35.5	36.8	58.0	58.0	63.7	67.9	81.1	84.0	106.0	108.9	119.5	122.6	SD 800 CX	
Max. Shipping Weight	x 1000 lb	11.2	11.6	13.8	14.2	18.6	19.2	21.0	25.5	26.3	27.5	31.2	32.2	48.4	50.7	55.7	59.5	70.3	72.7	91.3	93.7	102.3	105.0	SD 800 CX	
Clearance for Tube Removal	inch	94.5																							
Absorbent Pump Motor Rating	kw (A)	1.1 (3.4)																							
Refrigerant Pump Motor Rating	kw (A)	2.2 (6.0)																							
Purge Pump Motor Rating	kw(A)	0.3 (1.4)																							
Total Electric Input	kVA	5.7	7.6	7.6	7.6	7.6	7.6	9.1	9.1	11.2	11.2	13.4	13.4	16.0	16.0	18.1	18.1	20.3	20.3	20.3	20.3	20.3	20.3	SD 800 CX	
Power Supply		460 V(±10%), 60 Hz (±5%), 3 Phase+N																							

- Notes:
- Chilled water inlet / outlet temperature = 54 / 44 °F
 - Cooling water inlet temperature = 85°F
 - Minimum Cooling water inlet temperature is 50°F
 - Steam at Control Valve Inlet is at 113.78 psi(g) pressure
 - Technical specification is based on ARI 560 : 2000
 - Maximum Allowable pressure in chilled / cooling water system = 113.78 psi(g)
 - Maximum Allowable pressure in steam system = 149.35 psi(g)
 - Ambient condition shall be between 41 to 113°F
 - All Water Nozzle connections to suit ASME B16.5 Class 150
 - Control panel Electric Input = 1kVA



High Temperature Hot Water

Model Number	UNITS	HD 20A CX	HD 20B CX	HD 20C CX	HD 20D CX	HD 30A CX	HD 30B CX	HD 30C CX	HD 40A CX	HD 40B CX	HD 40C CX	HD 50A CX	HD 50B CX	HD 60A CX	HD 60C CX	HD 60D CX	HD 70A CX	HD 70B CX	HD 80A CX	HD 80B CX	HD 80C CX	HD 80D CX											
Cooling Capacity	TR	111	130	162	192	240	272	320	360	408	452	505	560	636	709	802	890	993	1107	1251	1372	1570	1685										
Flow rate	GPM	268.1	313.9	391.0	463.6	579.4	656.5	772.7	869.1	984.9	1091.0	1219.2	1351.7	1535.3	1711.4	1935.9	2148.6	2397.4	2672.5	3019.9	3312.3	3790.0	4087.8										
No. of passes (Evaporator)	#	3	3	2	2	2	2	2	2	2	2	2	2	3	3	2	2	2	2	2	2	2	2										
Friction loss	ftWC	13.1	15.4	15.7	19.4	15.1	16.7	25.6	21.3	22.3	24.3	21.7	22.0	21.3	22.6	14.4	15.4	14.8	16.1	12.5	13.5	21.3	22.3										
Connection Diameter	inchNB	4				6				6				8				10				12											
Flow rate	GPM	488.7	572.4	713.3	845.4	1056.7	1197.6	1408.9	1563.0	1774.4	1990.1	2163.8	2426.0	2800.2	3121.6	3531.1	3918.6	4396.2	4887.2	5283.4	5723.7	6192.5	6956.5										
Outlet Temp	°F	94.5	94.5	94.5	94.5	94.5	94.5	94.5	94.5	94.5	94.5	94.6	94.6	94.5	94.5	94.5	94.5	94.4	94.4	94.8	95.0	94.5	95.0										
No. of passes (absorber)	#	3	3	2	2	2	2	2	2	2	2	2	2	2	2	1	1	2	1	2	2	1	1										
No. of passes (condensor)	#	1	1	1	1	1	1	1	1	1	1	1	1	1	1	1	1	1	1	1	1	1	1										
Friction loss	ftWC	12.8	12.5	14.8	15.4	14.8	15.1	22.3	21.0	21.3	22.6	22.6	24.0	25.3	25.9	17.7	18.7	36.4	19.7	34.8	36.4	23.6	23.3										
Connection Diameter	inchNB	6				8				10				10				14				16											
Flow rate	GPM	75	87	109	129	161	182	215	241	274	303	339	376	425	472	539	597	665	740	835	916	1051	1130										
No. of passes	#	6	6	6	6	6	6	4	4	4	4	4	4	4	4	3	3	3	3	3	3	3	3										
Friction loss	ftWC	7.5	7.4	19.3	19.5	21.4	21.8	10.9	11.2	11.1	10.5	10.4	10.5	14.4	14.6	12.2	12.4	12.5	12.4	12.3	13.2	21.6	22.4										
Connection Diameter**	inchNB	3			4			4			6			6			6			8			8										
Length	inch	115.7	115.7	155.9	155.9	162.6	162.6	186.6	191.3	191.3	191.3	198.8	198.8	261.4	261.4	310.2	310.2	305.9	305.9	318.1	318.1	367.3	367.3										
Width	inch	83.5	83.5	78.3	78.3	85.0	85.0	85.0	85.0	88.0	88.0	105.1	105.1	114.2	114.2	114.2	124.8	124.8	140.2	140.2	140.2	140.2	140.2										
Height	inch	100.8	100.8	100.8	100.8	106.3	106.3	114.2	114.2	114.2	114.2	125.2	125.2	132.3	132.3	132.7	147.2	147.2	160.2	160.2	160.2	160.2	160.2										
Operating Weight	x 1000 lb	12.3	12.8	15.2	15.9	20.9	21.6	23.6	28.9	30.0	31.3	35.5	36.8	55.3	58.0	63.7	67.9	81.1	84.0	106.0	108.9	119.5	122.6										
Max. Shipping Weight	x 1000 lb	11.2	11.6	13.8	14.2	18.6	19.2	21.0	25.5	26.3	27.5	31.2	32.2	48.4	50.7	55.7	59.5	70.3	72.7	91.3	93.7	102.3	105.0										
Clearance for Tube Removal	inch	94.5				161.4				177.4				161.8				218.5				258.3				311.4							
Absorbent Pump Motor Rating	kW (A)	1.1(3.4)				2.2(6.0)				2.2(6)				3.0(8)				3.7 (11)				5.5 (14)				6.6 (17)				7.5 (20)			
Refrigerant Pump Motor Rating	kW (A)	0.3(1.4)																															
Purge Pump Motor Rating	kW(A)	0.75(1.8)																															
Total Electric Input	kVA	5.7	7.6	7.6	7.6	7.6	7.6	9.1	9.1	11.2	11.2	13.4	13.4	16.0	16.0	18.1	18.1	20.3	20.3	23.6	23.6	27.3	27.3										
Power Supply		460 V (±10%), 60 Hz (±5%), 3 Phase+N																															

- Notes:
- Chilled water inlet / outlet temperature = 54 / 44 °F
 - Cooling water inlet temperature = 85°F
 - Minimum Cooling water inlet temperature is 50°F
 - Hot water inlet / outlet temperature = 350 / 325 °F
 - Control panel Electric Input = 1kVA
 - Maximum Allowable pressure in chilled / cooling water system = 113.78 psi(g)
 - Maximum Allowable pressure in Hot water system = 149.35 psi(g)
 - Ambient condition shall be between 41 to 113°F
 - All Water Nozzle connections to suit ASME B16.5 Class 150
 - Technical specification is based on ARI 560 : 2000
- ** Connection diameter can vary depending upon actual conditions

➤ Typical System P&I Diagram

Single Effect Steam Driven Absorption Chiller

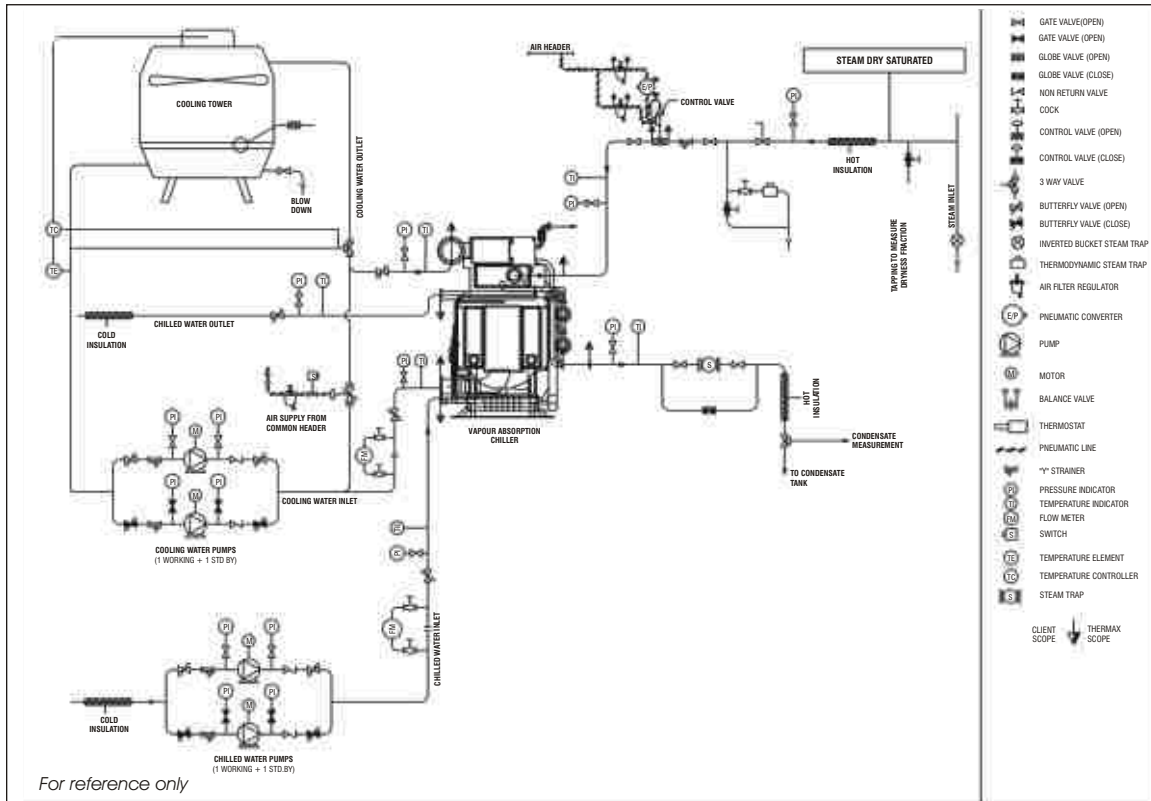

➤ Typical General Arrangement Drawing

Single Effect Steam Driven Absorption Chiller

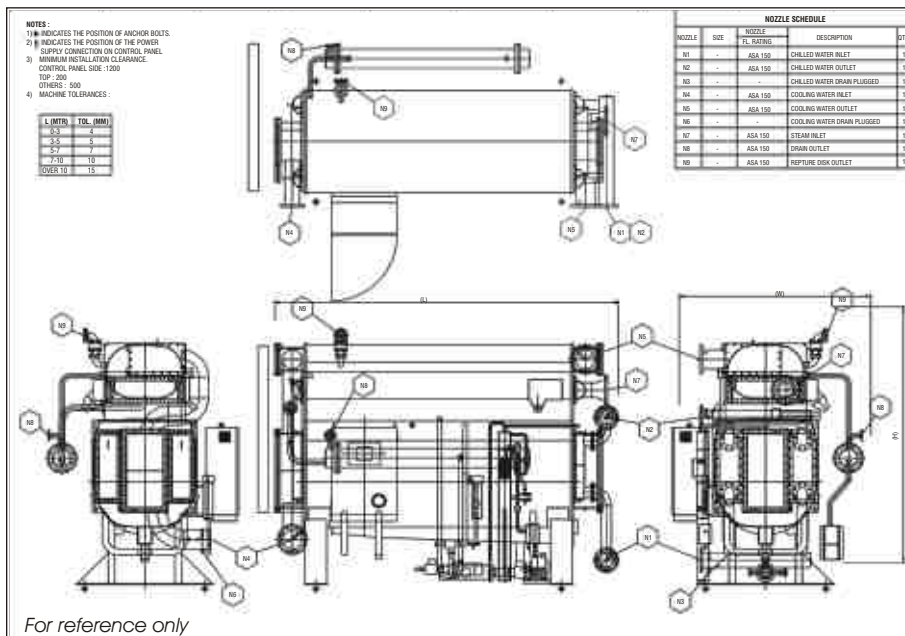

➤ Typical System P&I Diagram

Double Effect Steam Driven Absorption Chillers

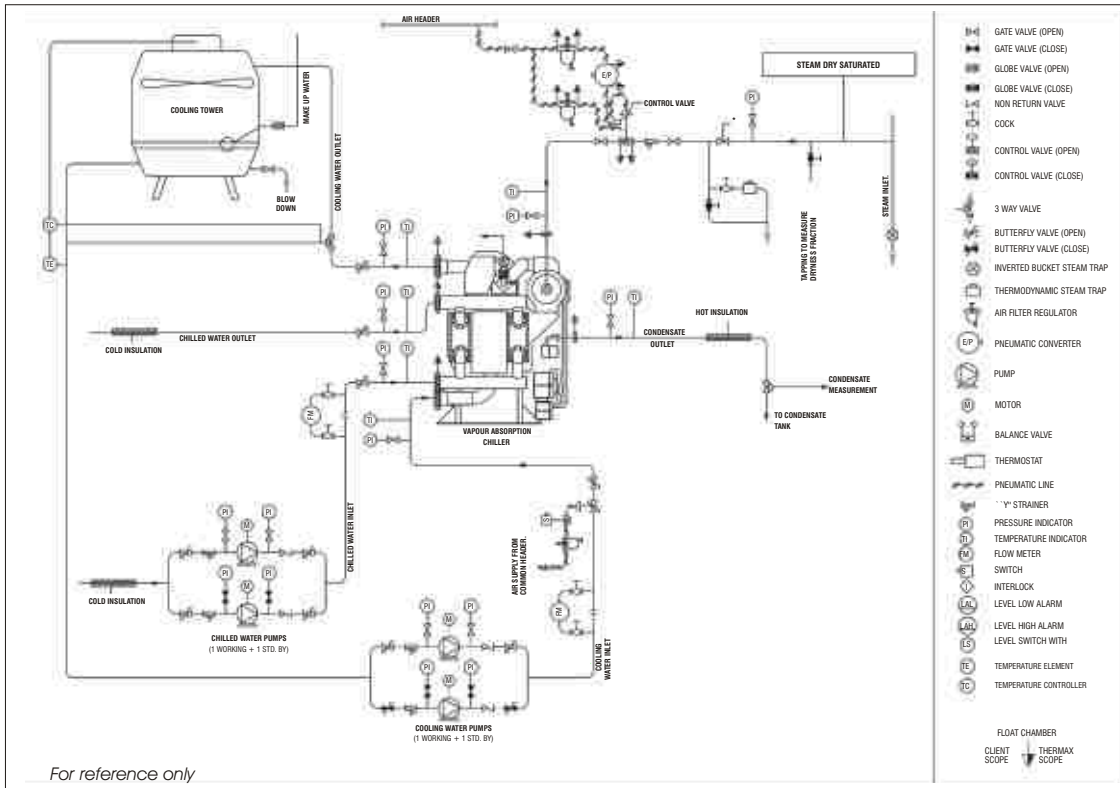

➤ Typical General Arrangement Drawing

Double Effect Steam Driven Absorption Chillers

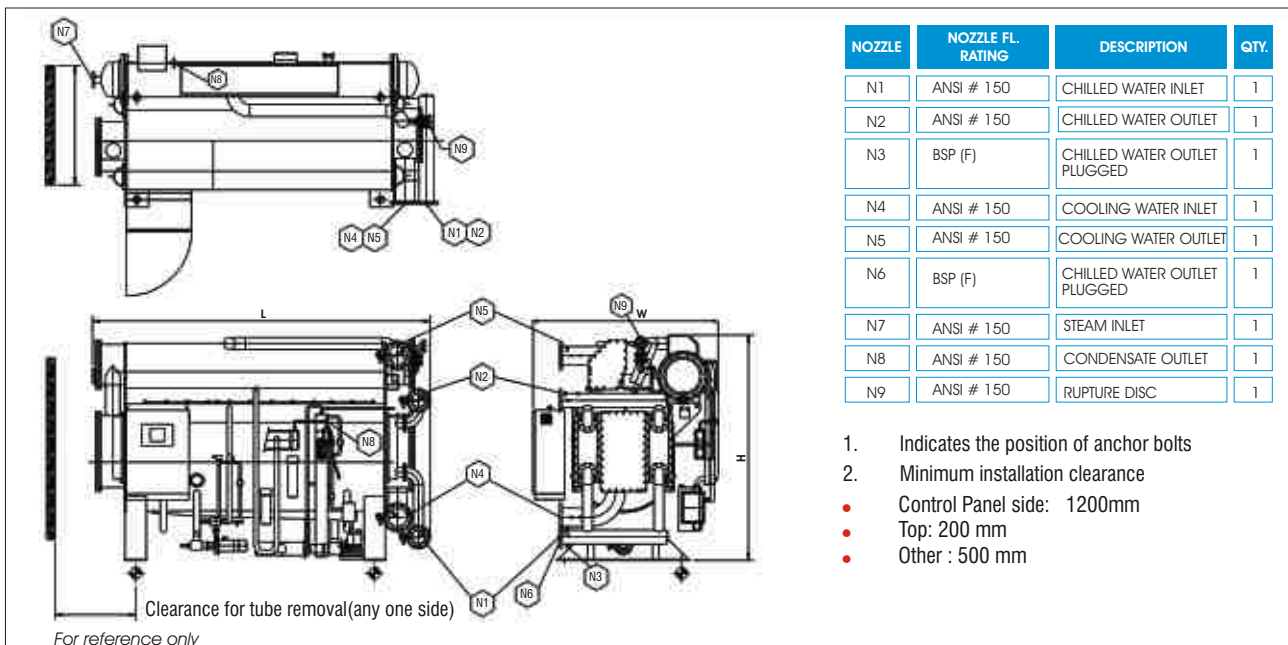

➤ Instrumentation And Safety Features

Control Logic

The control panel includes the following components:

- Programmable Logic Controller (PLC)
- Panel view operator interface
- Power circuit for pumps
- Panel mounted instruments

The total heat extracted from the chilled water defines the cooling capacity of a chiller. The chilled water inlet flow-rate is kept constant. Hence the cooling capacity is proportional to the difference in the temperatures of the chilled water at inlet and outlet.

Load changes are reflected in the rise or fall of the temperature of the inlet chilled water. The outlet chilled water temperature varies with the inlet chilled water temperature. An RTD sensor notes this change in temperature. This temperature signal is fed to the PLC.

An inbuilt software PID control loop processes this signal with respect to the chilled water set point. A control output signal of 4 to 20 mA is sent to the I/P converter.

The I/P controller converts the 4 to 20 mA electrical signal



to a 2.8 to 14.5 psi (g) pneumatic signal, which controls the position of the steam control valve. As the load increases, the steam control valve also opens, and vice-versa, thus regulating the quantity of steam entering the chiller.



Safeties

Safety devices are provided to protect the chiller from reaching abnormal conditions, to safeguard it from damage and to ensure continued availability.

Safety devices are:

- Chiller mounted safeties, located on the chiller
- Panel mounted safeties, on the control panel and
- Field interlocks, passing signals from the field to the chiller

Chiller mounted

- Chilled water flow switch
 - Paddle type device mounted on the chilled water outlet nozzle
- Chilled water Differential Pressure (DP) switch
 - Connected to inlet and outlet chilled water nozzles
- Refrigerant level electrodes
 - Mounted in the refrigerant level box
- Generator level electrodes
 - Mounted in the high temperature generator level box
- Absorber level electrodes
 - Mounted in the absorbent level box
- Auto blow-down solenoid valve
 - Mounted on refrigerant pump outlet tapping to Absorber
- Solenoid valve on condensate drain
 - Mounted on drain line from heat reclaimer outlet
- Temperature sensors mounted at various locations to display temperatures.

Panel Mounted

- Generator level controller
- Refrigerant level controller
- Absorbent level controller
- Absorbent pump overload relay/ AC Drive (if applicable)
- Refrigerant pump overload relay
- Purge pump overload relay

Field interlocks

- Chilled water pump interlock
- Cooling water pump/ butterfly valve interlock

Safety Functions

The safety functions of the chiller protect it against abnormal conditions. The various functions are:

Thermal shock protection

To protect the chiller from a thermal shock, the steam control valve is opened gradually for the first 10 minutes after chiller start up. At this moment, the HTG temperature is less than 212°F. After the slow opening duration is over, the control automatically switches over to the chilled water temperature.

Antifreeze protection

To prevent the chilled water from freezing in the evaporator tubes, there are various safety functions to stop the chiller like:

- **L-cut:** The refrigerant pump is switched off in case the chilled water outlet temperature drops below the L-cut set point. The L-cut is set from the cool mode control loop screen. This safety prevents a further drop in the chilled water temperature. The refrigerant pump will restart after the chilled water outlet temperature rises above the L-cut set point plus the hysteresis set point.
- **Antifreeze:** If the chilled water outlet temperature drops below the antifreeze set point, the chiller trips and the 'TOTAL SHUTDOWN' alarm sequence is carried out. The alarm should be reset only after the chilled water outlet temperature rises above the antifreeze set point plus the hysteresis set point.
- **Chilled water pump interlock:** Chilled water flow is a prerequisite for chiller operation. A potential free contact is wired from the chilled water pump motor starter to chiller panel to sense chilled water pump ON/ OFF/ TRIP status. The chiller starts only when the chilled water pump is ON. If the chilled water pump stops/ trips during operation, the 'TOTAL SHUTDOWN' alarm sequence is carried out.
- **Cooling water pump interlock:** Cooling water flow should be stopped immediately when the chilled water flow stops in the chiller. So, the cooling water pump should be started through the start permissive of cooling water pump.
- **Chilled water flow switch:** If the chilled water flow drops below 50% of the rated value, 'TOTAL SHUTDOWN' alarm sequence is carried out.
- **Chilled water differential pressure switch:** If the chilled water flow drops below 50 to 60% of the rated value, the 'TOTAL SHUTDOWN' alarm sequence is carried out. Electrical wiring should be done such that

if the flow switch or differential pressure switch operates, either all the cooling water pumps should stop or the pneumatic butterfly valve in cooling water circuit should close instantly.

- **Butterfly control valve in cooling water line:** If all the cooling water pumps can be stopped electrically when the differential pressure switch or flow switch shows less or no flow of chilled water, automatically operated butterfly valve is not required. However, when such arrangement cannot be ensured, auto butterfly valve needs to be provided by the customer to stop the cooling water based on the differential pressure switch/ flow switch signal.

Crystallization prevention

(Double effect) If the concentrated absorbent solution, while returning to the Absorber from the Low Temperature Generator is excessively cooled, it crystallizes in the Low Temperature Heat Exchanger, thus affecting the operation of the chiller. Crystallization occurs either when the concentration of the absorbent (related to its temperature) becomes too high or its temperature drops excessively.

The following safety functions prevent the chiller from crystallizing:

- **Steam control valve modulation on crystallization prevention safety:** The strong solution concentration and the crystallization temperature corresponding to that concentration are calculated in the PLC. The PLC always tries to maintain the pre-set safe distance between the crystallization temperature and strong solution temperature of low temperature heat exchanger outlet. If the distance is less than the pre-set safe distance, the PLC modulates the steam control valve so that the strong solution will never reach crystallization zone.
- **Absorber level safety:** (Double effect) Crystallization in the chiller can result in low absorber level. When the absorber level falls below 25% of the sight glass, the auto blow-down solenoid valve opens to transfer the refrigerant to the Absorber thus building up the absorber level again. If the absorber level goes further below the safe zone, the steam control valve closes fully. When the absorber level rises back to 50% of the sight glass, the auto blow-down valve shuts, steam control valve opens and the chiller starts operating automatically. Adequate level ensures dilute solution supply to the Generator thus preventing crystallization.
- **Cooling water low temperature safety:** If the cooling water inlet temperature drops below the

cooling water low temperature set point, the 'DILUTION CYCLE' alarm sequence is carried out. The chiller goes into the dilution cycle immediately. The alarm can't be reset until the cooling water inlet temperature rises above the cooling water low temperature set point plus the hysteresis set value. During initial start-up, this safety is bypassed till the generator temperature reaches 248°F. The safety is in operation, 30 minutes after the chiller start-up, irrespective of the generator temperature.

- **Valve control on HTG temperature:** When the HTG temperature exceeds the set point minus 3.6°F, the steam control valve closes immediately. This prevents further increase in the LiBr concentration. The valve control is returned to the chilled water temperature control loop when the HTG temperature drops below set point minus 7.2°F.
- **HTG Vapor saturation temperature high:** (Double effect) If the HTG vapor saturation temperature exceeds the HTG vapor temperature set point, the 'DILUTION CYCLE' alarm sequence is carried out. The chiller goes into the dilution cycle. The alarm can't be reset until the HTG vapor temperature goes below the HTG vapor temperature trip set point minus the set hysteresis value.
- **HTG high temperature safety:** If the HTG temperature exceeds the HTG high temperature set point, the 'DILUTION CYCLE' alarm sequence is carried out. The chiller goes into the dilution cycle. The HTG high temperature alarm can't be reset until the HTG temperature drops below the set point minus the hysteresis set value 9°F. This set point may vary slightly for non-standard chillers.

Cavitation protection of refrigerant pump

The refrigerant pump starts to cavitate, when the refrigerant level in the evaporator pan falls below the set level.

To ensure the minimum acceptable suction pressure, the refrigerant level is not allowed to fall below a certain level by means of three level electrodes and a level relay. The three electrodes are mounted in the refrigerant level box assembly present on the lower shell. The pump starts when the level reaches the electrode that is smallest in length. It stops when the level goes below the longest electrode. When the level goes below the intermediate electrode, a delay of 20 seconds is provided before the pump can be switched off.

Cavitation protection in the absorbent pump

The absorbent pump starts to cavitate when the absorbent level in the absorber sump falls below the set level. The level of the absorbent is controlled to ensure a minimum acceptable suction pressure. To prevent the excess absorbent from being pumped out of the absorber sump, the absorbent level in the HTG is not allowed to rise above a certain level. This is done by means of three level electrodes, and a level relay.

The three electrodes are mounted in the high temperature generator level box. The absorbent level is to be maintained below the smallest electrode. The longest electrode acts as the reference electrode. When the level reaches the smallest electrode, the pump stops after a delay of 5 seconds. It restarts when the level goes below the intermediate electrode.

Motor protection

- **Absorbent pump overload relay:** If the absorbent-pump motor draws more than its rated current, this overload relay trips. The 'TOTAL SHUTDOWN' alarm sequence is carried out. The alarm cannot be reset until the absorbent pump overload relay (inside the control panel) is reset manually.
- **Refrigerant pump overload relay:** If the refrigerant pump motor draws more than its rated current, this overload relay trips. The 'DILUTION CYCLE' alarm sequence is carried out. The alarm cannot be reset until the refrigerant pump overload relay inside the control panel is reset manually.
- **Purge pump overload relay:** If the purge pump motor draws more than its rated current, this overload relay trips. The alarm cannot be reset until the purge pump overload relay inside the control panel is reset manually.

➤ Machine Room Layout Considerations



Location

Unlike conventional electric chillers, absorption chillers are characterized by their silent operation and simpler foundation. Owing to this, they can be located in basements or on terraces of buildings; the location being ultimately decided by space availability and ease of installation and maintenance.

Room Size

The machine room size should be decided according to dimensions of the chiller. A minimum of 3.3ft clearance space should be kept on all sides of the chiller. In addition, provision for tube removal space should be made on either sides of the chiller. A clearance of 3.95 ft is recommended on the panel side of the chiller and 0.7 ft is recommended on the top of the chiller. For more details please refer to the dimensional data given in this document.

Ambient Temperature

Temperature in the chiller room should be between 4°F and 113°F.

Humidity

The humidity inside the chiller room should be less than 85%. High humidity can result in corrosion and failure of electrical equipment. The chiller room should be adequately ventilated.

Drainage

All discharge pipes and overflow pipes should be routed to the drains. The drains should be kept covered. The slope of the drainage system should be such that there is no accumulation of water. In case the chiller room is built in the basement, a water tank and pump is required for proper drainage.

Piping Guidelines

- Steam piping should be designed and installed to meet the safety standards prescribed for the pressure vessel. Pipe sizing should be as per the required flow rates.
- In the connecting lines, field instruments should be installed adjacent to the chiller. Pipe design and its routing should provide easy access to the field instruments (for e.g. during maintenance).
- The crossover piping from the Absorber to the Condenser is a standard feature of Thermax absorption chiller.
- The piping should be adequately supported to prevent any strain on the chiller nozzles and connecting flanges.
- Check whether air-vent valves, drain valves and pressure gauges are provided on the chilled water, cooling water, fuel and drain piping. The drain connections should be at the lowest point, whereas the air-vents should be at the highest point on the piping.
- The inlet chilled water line and inlet cooling water line to the chiller should be flushed clean, before connecting these to the chiller.
- Check the connective direction of the chilled water and the cooling water piping.
- Check the valve positions on the chilled water piping, cooling water piping, steam and drain piping.
- Make sure that strainers are provided in the water circuits.
- If cooling water pump is not dedicated to individual chiller, auto-operated butterfly valve is necessary in the cooling water circuit.

Electrical Guidelines

- All field wiring should be in accordance with applicable codes.
- Use copper conductors only.
- All wiring should be checked regularly for any damage and all terminal connections tested for tightness.
- The power supply specifications should match **with** those given on the unit nameplate. Voltage must be within 15% of nameplate value.
- For minimum circuit ampacity and maximum fuse size, see the unit nameplate.
- Wiring to the control panel should be proper.
- Proper wiring should be provided from the control panel to control valve.
- Proper interlocking of chilled water and cooling water with the chiller control panel should be provided.

Insulation Guidelines

- Use adhesive agents, iron wires and bounds to mount insulation material. These should not be fixed/ mounted using tapping screws or rivets.
- Use non-combustible insulation material. This could be wool or polystyrene foam in case of cold surfaces, and glass wool in case of hot surfaces.
- The insulation should not cover the cap of the damper, sight glass, handle of the refrigerant blow-down valve, refrigerant pump motor, refrigerant level electrode box cover, HTG level electrode level box cover and the service valves.
- For effective in-tube cleaning, the evaporator header should be removable.
- To assist in-tube inspection, the insulation for the high temperature generator headers should be removable.
- In addition, the following components should also have removable insulation:
 - Chilled water flow switch
 - Chilled water freeze protection thermostat
 - Chilled water temperature sensor
- The chiller comes with rust preventive paint.

➤ Site Unloading And Installation

Unloading instructions

- For unloading purposes, use the lifting shackles provided on the chiller. Rigging from any other point on the chiller can damage the unit and cause personal injury.
- Use proper sized hooks/ slings and approved methods for lifting the chiller.
- Lift the chiller simultaneously from all four corners, while keeping the unit level with the ground.
- Proper care should be taken while hooking up the shackles near the pipes. (Refer figure)
- Every care should be taken to prevent damage to interconnecting pipes, control panel and chiller mounted panel.

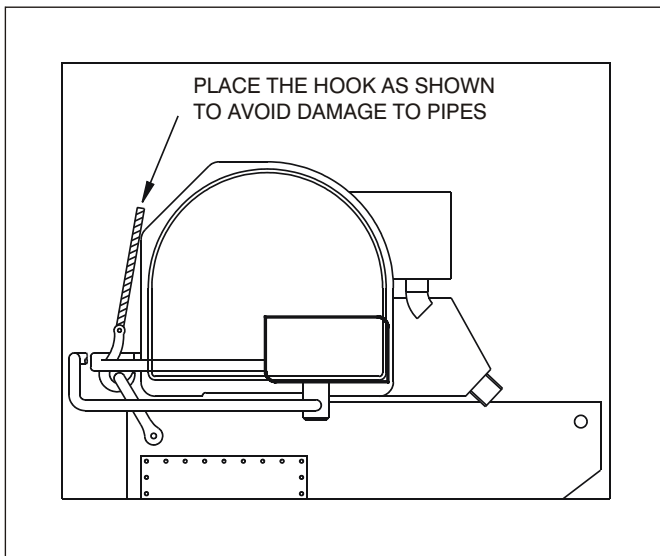

Unloading & Installation of machine

(Single piece): As a standard feature, the chiller is shipped as a single piece. All piping should be adequately supported and fitted to prevent any strain on nozzles and connecting flanges. During installation, sizes of cooling and chilled water lines should match with those of the connecting nozzles. Their inlet connections should be flushed clean, and electrical wiring should be verified. The sketch shown below, indicates the unloading of a single piece chiller.

Note: This is only a diagrammatic representation of the general appearance of the chiller. The actual chiller may be different than what has been shown here.

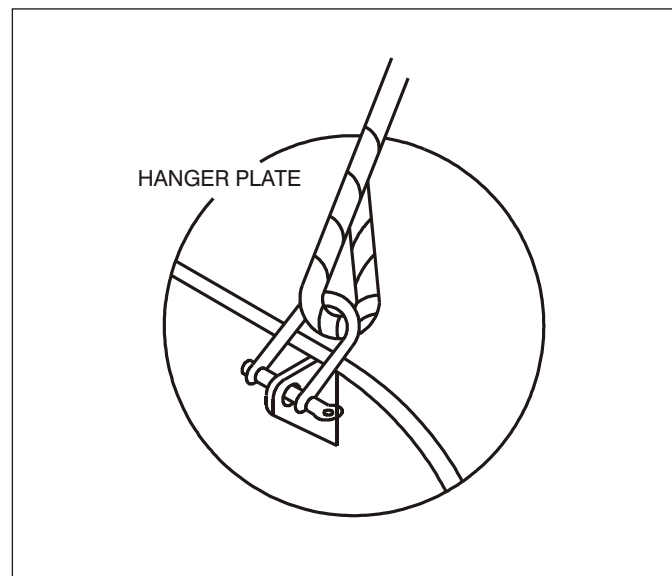
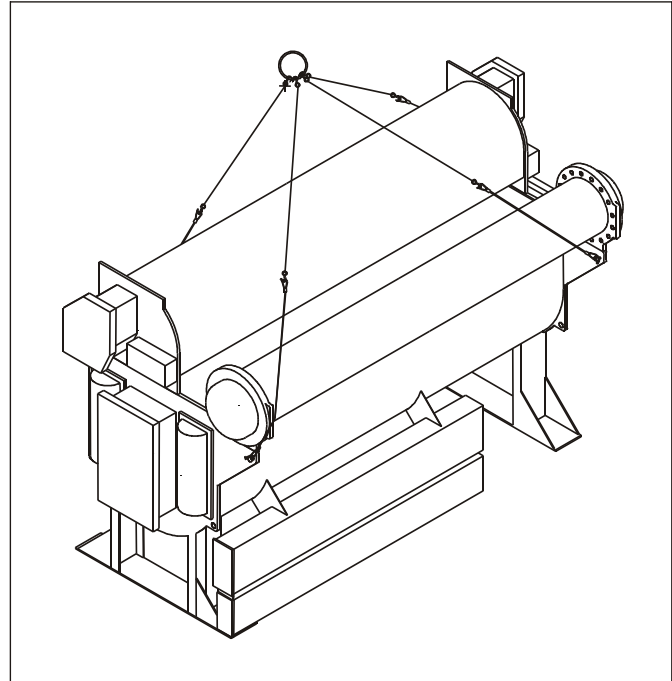

Rigging and Shifting to the foundation: To avoid any damage, the chiller should be rigged with care to its ultimate location. A plate should be placed beneath the saddles of the chiller, and castors or rollers placed below the plate. The chiller should be pulled gradually from one side using a winch. The wire rope used for pulling should be tied to the saddle.

Leveling of chiller: Before hooking up the chiller to the external piping, it is very important to level it based on the procedure given below. Proper leveling of the chiller is essential to achieve the rated capacity of the unit. Allowable tolerance (both lengthwise and side-wise) is less than or equal to 1/16 inch per 5 ft.

There are four leveling checkpoints provided on the heater. (Labeled as A, B, C and D in the figure below) These check points are designated by three punch marks on the tube sheet or shell of the lower shell of the chiller.

Procedure for leveling: Fill a clear vinyl hose (diameter of the hose 3/8") with water, ensuring that there are no air bubbles in it. Using point 'A' as reference point, measure the difference in the water level at the other points (i.e. B, C and D).

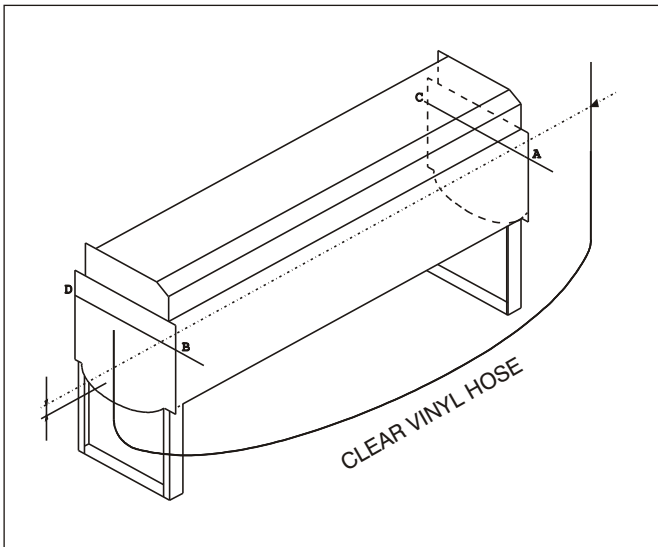

Leveling calculations are as shown below:

A	B	C	D
0inch	inch	inch	inch

$$\frac{A-B}{L} = \frac{C-D}{L} \quad \frac{A-D}{L} = \frac{B-C}{L} \quad \frac{A-C}{W} = \frac{B-D}{W}$$

Where,

L= Length of the chiller W= Width of the chiller

In case the required tolerance is not met, it can be achieved by inserting a metal shim between the chiller frame and foundation. Metal shim size could be approximately 2" width x 3" length, whereas the thickness of the shims should be in the range of 0.024" to 0.354". After making adjustments, confirm the leveling of the chiller by taking a new set of readings.

Procedure for grouting: After leveling the chiller, it is required to be grouted before the external piping can be connected to it. This is done by fixing the anchor bolts, by welding the washer to the chiller frame and by tightening the bolts.

Storage of the unit: In case the unit is not to be installed immediately, it should be kept covered until its installation. It is recommended to keep the chiller indoors during this period to prevent any damage to it. Nitrogen should not be removed from the chiller. All accessories supplied with the unit should be kept in the same place.

Optional Multi-sectional Shipment: The chiller can be shipped in three sections viz. the lower shell assembly, upper shell assembly and the HTG assembly. This is done when there are indications that the chiller's dimensions as a single piece may cause rigging problems (particularly during retrofit jobs).

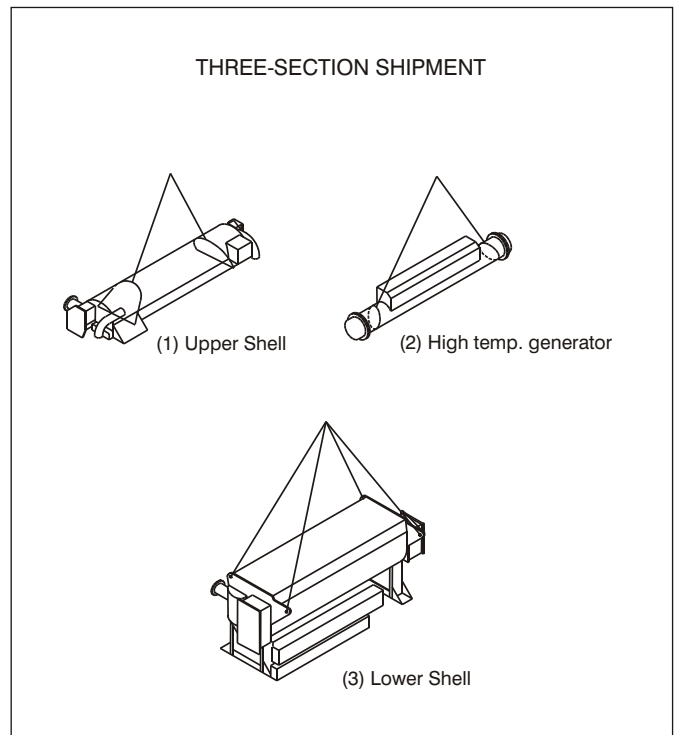



THERMAX

Sustainable Solutions in
Energy & Environment

COOLING & HEATING DIVISION

Thermax Ltd., India

D-13 MIDC Industrial Area, R.D. Aga Road, Chinchwad, Pune 411 019
India., Tel: 00-91-20-27475941, Fax: 00-91-20-27475907
www.thermaxindia.com

Thermax Inc, USA

Tel: 00-1-248-4743050, Fax: 00-1-248-4745790
Email: ssshastri@thermax-usa.com, rsinha@thermax-usa.com
www.thermax-usa.com

Thermax Europe Ltd., UK

Tel: 00-44-1908-378-914, Fax: 00-44-1908-379-487
Email: dinesh@thermax-europe.com
www.thermax-europe.com

Thermax (Zhejiang)

Cooling & Heating Engg. Co. Ltd., China
Tel: 00-86-21-64483996, Fax: 00-86-21-64483997
Email: knt@thermax-china.com
www.thermax-china.com

Thermax do Brasil

Tel: 00-55-21-25169227, Fax: 00-55-21-25169226
Email: rajesh.sinha@thermaxdobrasil.com.br
www.thermaxdobrasil.com.br

Thermax Rus Ltd., Russia

Tel: 00-7-095-9350490/ 91, Fax: 00-7-095-1347410
Email: thermax-moscow@concord.ru

Thermax Ltd., UAE

Tel: 00-971-4-8816481, Fax: 00-971-4-8816039
Email: pmittal@thermaxdubai.ae, thermax@emirates.net.ae

Thermax Ltd., Saudi Arabia

Tel: 00-966-3-8575056, Fax: 00-966-3-8575068
Email: shafi@thermaxme.com

Thermax Ltd., Kenya

Tel: 00-254-204440233, Fax : 00-254-204451919
Email: thermax.ing@hyperia.com

Thermax Ltd, Nigeria

Tel: 00-234-8022908770, Fax: 00-234-14936187
Email: thermax.ing@hyperia.com

Thermax Ltd., Thailand

Tel: 00-66-2-6555790, Fax: 00-66-2-6555791
Email: ngupta@trueemail.co.th

Thermax Ltd., Malaysia

Tel: 00-60-3-21669801, Fax: 00-60-3-21669802
Email: thermax@tm.net.my

Thermax Ltd., Indonesia

Tel: 00-62-21-83793259, Fax: 00-62-21-83793258
Email: venkat@thermaxindonesia.co.id

Thermax Ltd., Philippines

Tel: 00-63-2-9296964, Fax: 00-63-2-9296982
Email: kaustubh.thermax@gmail.com

Thermax Ltd., Bangladesh

Telefax: 00-880-29885823, Mob: 00-880-1912008882
Email: madhav@worldnetbd.net

Thermax Ltd., Srilanka

Tel: 00-94-777769126, Fax: 00-94-112533217
Email: dhananjaya@alangroup.com

www.thermaxindia.com

In view of our constant endeavour to improve the quality of our products, we reserve the right to alter or change specifications without prior notice. All photographs shown in this publication are representative in purpose, and to be used for reference only. For actual details and specifications, please refer to Thermax offer document

