



Series EA High Torque Actuators with Integrated Controller

Contents

1. Introduction	2
2. Specifications	3
3. Model Number	4
4. Installation	5
5. Wiring and Setup	9
6. Configuration	13
7. Mounting Dimensions	18
8. Retrofit Kits	19

For use with VB-7000 and VB-9000 Series valve bodies from Barber-Colman and many other commercially available rotary shaft valve bodies with crank arm and combustion air dampers.

Used for proportional control of dampers and valves in industrial applications. Typical applications are heat treat furnaces, ovens, heat recovery systems, water or oil cooling systems.

Features

- 550, 1100 and 1300 lbs./in. Models Available
- Die Cast Housings with Four 1/2" Conduit Openings
- Oil Immersed Motor and Gear Train

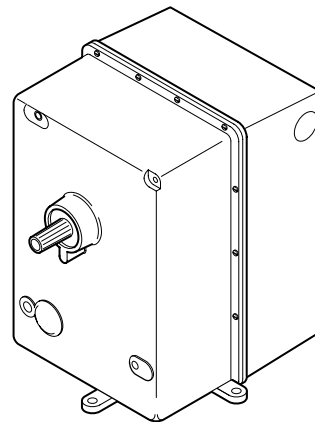

High Torque Actuator w/Controller

1. Introduction

Actuators of this family may be easily identified by referring to the part number shown on the nameplate on top of the gear case. The date of manufacture is stamped on the case as a four digit number. The first two digits represent the week of the year, the last two digits represent the year.

These actuators meet the requirements of both damper control and valve control applications where it is desirable to move the load in either direction, or to stop it at any point in the stroke. All models contain circuits for true position-proportional control.

Actuators are shipped without mounting hardware or linkage. In damper applications, crank arms, connectors, link rods and mounting brackets will be required. In valve applications, valve bodies and AV type linkages will be required.

Before installing the actuator, look for bent or broken parts or oil leaks. Actuators should be connected to a power supply to check operation prior to installation.

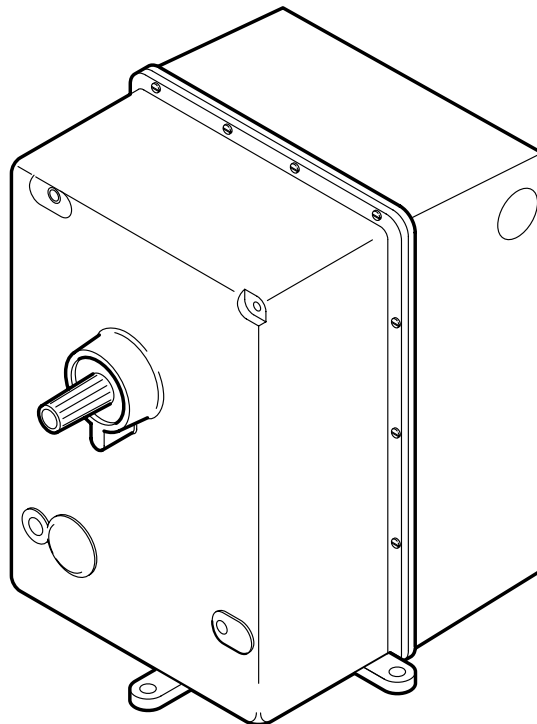

High Torque Actuator w/Controller

2. Specifications

Control Action:

Current Input: Factory set at 4 to 20 mA. Span adjustable from 10 to 23 mA. Zero point adjustable from 0 to 6 mA.

Voltage Input: 0-1 Vdc, 1-5 Vdc and 3-15 Vdc, switch selectable. Other ranges can be set in the configuration mode.

Resistance Input: Any potentiometer value from 100 Ohms to 1000 Ohms can be used for the input signal.

Input Impedance:

mA Input: 250 Ohms

Vdc or Resistance input: >100K Ohms

Direction of Travel:

Factory set to CCW with increasing signal. Can be changed in configuration mode.

Stroke Length:

Factory set for 180° rotation at full scale. Can be changed to 90° by setting a switch. Other lengths can be achieved in the configuration mode.

Control Overrides:

Dry contact closure can force the actuator to either end of travel.

Deadband:

Adjustable from 1% to 6% of span in 0.4% increments.

Ambient Temperature:

-40° to 54°C.

Humidity:

5 to 95% rh, non-condensing.

Power Requirements:

120 Vac, 190 W.

Option Board (check factory for availability):

A 4 to 20 mA position signal and two form C relays rated at 3 Amps, resistive. The relays can be set to activate at any point within the operating range.

High Torque Actuator w/Controller

3. Model Number

E A 7 - **A** - **0 0 3 - 0 - 0 0**
 1 2 3 4 5 6 7 8 9 10 11 12 13 14 15

Fields 1, 2. EA Series Actuators

Fields 3, 4. Base Model

Time	lbs./in. Torque
72 - 40	550
74 - 65	1100
76 - 115	1300

Field 5. Control Input

A - Analog input, proportional control

Field 6. Option Board

- 0 - None
- 1 - Position signal plus 2 relays

Fields 7, 8. Options

- Options 01 through 07 are not NEMA rated
- 00 - None
 - 01 - 2 auxiliary SPDT switches
 - 02 - 4 auxiliary SPDT switches
 - 03 - Rear shaft
 - 04 - 100 Ohm rear slidewire
 - 05 - 100 Ohm rear slidewire and 2 switches
 - 06 - 1000 Ohm rear slidewire
 - 07 - 1000 Ohm rear slidewire and 2 switches

Fields 7, 8. Options (continued)

- Options 37 through 43 are NEMA rated
- 37 - NEMA 4 cover
 - 41 - 100 Ohm rear slidewire, weather resistant
 - 42 - Two 100 Ohm rear slidewires, weather resistant
 - 43 - Three 100 Ohm rear slidewires, weather resistant

Field 9. Voltage/Frequency

0 - 120 Vac, 60 Hz

Fields 10, 11. Reserved

Field 12. Slidewire

3 - 1000 Ohm

Field 13. Reserved

Fields 14, 15. Specials

00 - None

High Torque Actuator w/Controller

4. Installation



CAUTION!

Disconnect the power supply (line power) before installation to prevent injury and equipment damage!

Make all connections in accordance with the wiring diagram and in accordance with national and local electrical codes.

Use copper conductors only!



CAUTION!

Do not exceed the ratings of the devices!

Avoid locations where excessive moisture, corrosive fumes, or vibration are present!

Damper Mounting

Upright mounting is preferred, but other positions are acceptable. For longest life, minimum ambient temperature should not exceed -40°F (-40°C) and maximum temperature should not exceed 130°F (54°C)

Linkage Assembly

One of the most common linkages is one in which the actuator stroke is 180° and the driven stroke is 90° .

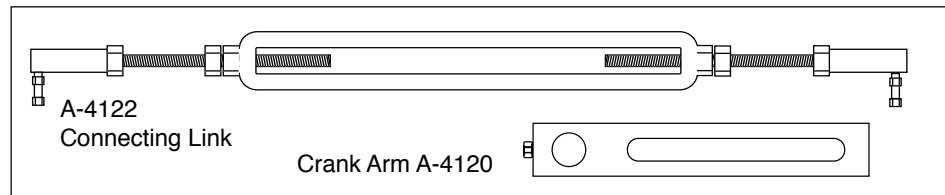

Figure 1. Linkage Components



CAUTION!

The damper must not be mechanically stopped before the actuator has reached its electrical limit of travel or permanent damage can occur to the actuator!

1. During installation of the linkage assembly, the actuator should be powered and be able to be controlled manually.
2. Turn driven shaft back and forth to determine full closed and full open positions.
3. Mount the crank arm on the driven shaft so that the location of the linkage connector in full closed and full open positions (points C1 and C) will fall on a straight line through the center of the actuator shaft. See Figure 2.

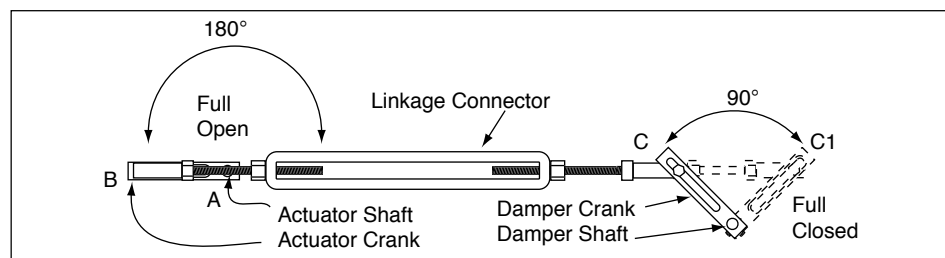

Figure 2. Linkage installed

High Torque Actuator w/Controller

4. Secure one of the connecting links in the driven linkage connector.
5. Run the actuator to the closed position and loosely set the crank arm on the actuator shaft. Do not tighten the arm on shaft.
6. With the crank arm still mounted loosely on the actuator shaft, fasten the linkage connector at about mid-position of the crank arm slot. Move the driven crank arm between full open and full closed positions. If the radius of that actuator crank is 0.707 times the radius of driven crank, 180° movement of actuator crank arm will position driven shaft 90°.
7. Move the driven crank arm to the closed position and hold firmly in place. Secure the crank on the actuator shaft (point A) and linkage connector so that points A, B and C1 are in a straight line.
8. Check adjustment for proper operation by running the actuator and driven shaft several times between the open and closed positions. If the driven crank arm does not provide tight closing, run the actuator a few degrees away from the closed position and reset the connecting link in the driven linkage connector. The driven crank arm will then provide closing under slight pressure.



CAUTION!

If the crank arm does not provide proper travel, reset the linkage. Never attempt to turn the actuator shaft with a wrench or crank; this may damage the actuator!

Valve Installation

Install all globe type valves with pressure under the seat except where a flow direction arrow on the valve body indicates otherwise. For best control, 3 way valve applications should be designed to use mixing valves. Preferred mounting is with the valve stem upright, but they can be mounted in other positions. For longest life, minimum ambient temperature should not exceed -40°F (-40°C) and maximum temperature should not exceed 130°F (54°C).

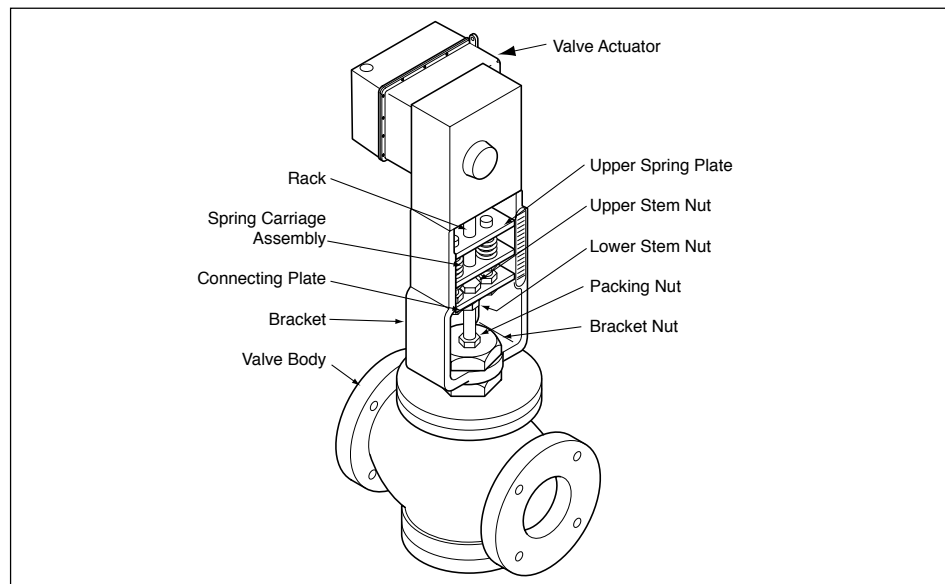

Figure 3. Typical Valve/Actuator Assembly Components

High Torque Actuator w/Controller

Valves are normally factory assembled and tested prior to shipment, but when necessary to assemble the valve, proceed as follows:

Note: Do not tamper with springs or spring carriage settings. These are critical and are factory set.

Note: Information for linkage kits to Barber-Colman Series VB-7000 and Series VB-9000 valves is available as accessory information in document 1322-IN-007-0-XX. Linkage to other valve bodies of similar stem stroke and collar size may be achieved by adjustment of these linkage kits.

To remove actuator from valve assembly:

- 1) Run actuator to release stem compression.
- 2) Loosen four actuator mounting screws.
- 3) While supporting actuator, remove screws and disengage pinion from rack.
- 4) Remove pinion and washer from shaft.

To mount pre-assembled actuator and linkage assembly on valve:

- 1) Run actuator to closed (stem down) position.
- 2) Remove bracket nut from valve.
- 3) Screw lower stem nut to bottom of threads on stem.
- 4) Place complete actuator and linkage assembly over valve stem and bonnet until stem extends through hole in connecting plate.
- 5) Rotate actuator and linkage assembly to desired position and secure with bracket nut.
- 6) Tighten lower stem nut against connecting plate.
- 7) Set compression as follows:
 - Loosen upper stem nut (if nut exists). Run actuator CW to closed position. Tighten lower stem nut against connecting plate, taking up all play in linkage.
 - Screw upper stem nut on stem 1/16" from connecting plate for compression on lower seat. (See Figure 4.)
 - Run actuator CCW until connecting plate is tight against upper stem nut. Secure lower stem nut against connecting plate.

To mount linkage assembly on valve:

- 1) Remove bracket nut from valve and screw lower stem nut down to bottom of threads on stem.
- 2) Place rack and spring carriage in bracket such that stem extends through connecting plate.
- 3) Align bracket so position indicator faces desired direction; then tighten bracket nut.
- 4) See actuator mounting instructions.

To mount actuator on linkage assembly:

- 1) Determine lift of valve by measuring total movement of stem.
- 2) Set shaft travel to correspond with valve lift. One degree of shaft rotation is equal to 0.011" of stem lift.
 - Insert screw driver through hole near front of terminal block and engage notched cam. Turning cam CW (as seen from front of actuator) increases shaft rotation. Each click of cam represents approximately 3° shaft rotation.

High Torque Actuator w/Controller

- On three way valves only, add 5° rotation to total shaft travel to provide compression on upper seat.
- 3) With actuator in full CW (closed) position, rotate motor pinion until a pinion tooth lines up with center line of boss on actuator case (see Figure 5); slide washer and pinion on shaft. Mark this tooth for future reference.
 - 4) Looking at front of linkage (position indicator side), rotate rack until teeth point to the left.
 - 5) Align actuator so that marked tooth of pinion engages with third tooth space from top of rack. Mount actuator to linkage with the actuator mounting screws (4). Apply "Locktite," Grade CV to screw threads.

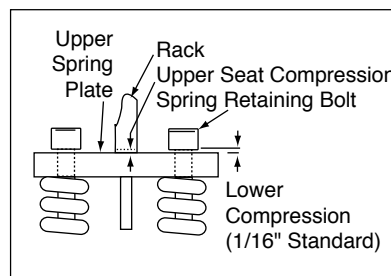

Figure 4. Compression

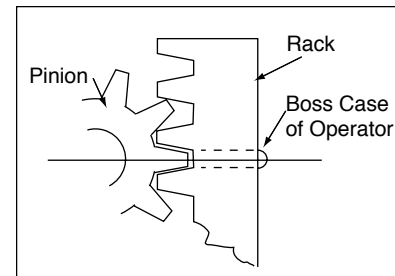

Figure 5. Rack and Pinion

To check compression:

Lower Seat: Run actuator to full closed (CW) position. Measure distance between head of spring retaining bolt and upper plate. (See Figure 4.)

Upper Seat (three way valves only): Run actuator to full open (CCW) position. Measure distance between bottom of rack and upper spring plate. To change compression on upper seat, adjust travel of actuator shaft. Standard spring compression is 1/16".

Checkout

After the system has been installed, the following checks for proper operation may be used:

- 1) Set controller to call for process variable decrease. Check actuator rotation to insure correct direction.
- 2) Set controller to call for process variable increase. Check actuator rotation to insure correct direction.

Note: Looking at the front of the actuator with the shaft facing you, a 4 mAdc input signal will cause the actuator to rotate CW. With a 20 mAdc input signal, the actuator will rotate CCW.

Maintenance

Minimum maintenance is required since the motor and gear train are submerged in oil for continuous lubrication and cooling. If necessary to refill the actuator with oil (refill capacity approximately 4.6 quarts), always use immersion oil (available in quart containers: BYZP-195-2). For best performance, oil level – with actuator upright – should be up to the edge of the oil fill hole which is located in the front case of the actuator.

High Torque Actuator w/Controller

5. Wiring and Setup

Power Connections

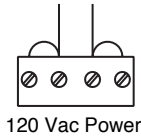

Power wiring is a Class 1 circuit. Route the wiring through the conduit opening on the left-rear side of the actuator, adjacent to the large terminal strip. Keep all wire within the safety barrier.

The large four terminal strip on the circuit board is for connection of power from the mains. A plastic barrier around the terminal strip and immediate area serves as a safety shield between Class 1 and Class 2 wiring.

Wire the power connections as shown to the left. Proper jumpers for the operating voltage are installed at the factory. Note that the operating voltage cannot be changed without physically changing the motor.

Control Connections

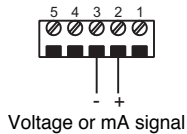

Control wiring is a Class 2 circuit. Route the wiring through the conduit opening on the right-rear side of the actuator, adjacent to the smaller five terminal strip. Keep all wire outside the safety barrier.

Input signals for mA or Vdc are connected to Terminals 2 & 3. Terminal 2 is the positive connection; Terminal 3 is the negative connection.

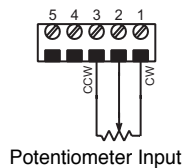

Input signals for potentiometers are connected to Terminals 1, 2 & 3. Terminal 1 is the CW connection; Terminal 2 is the wiper connection; Terminal 3 is the CCW connection.

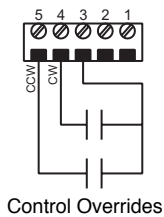

Control overrides allow forcing the actuator to end of travel on demand. They are commonly interfaced with combustion safeguard systems:

1. to drive the actuator full open during purge.
2. to drive the actuator full closed prior to ignition.

A dry contact closure between Terminal 3 and Terminal 4 will drive the actuator fully clockwise.

A dry contact closure between Terminal 3 and Terminal 5 will drive the actuator fully counterclockwise.

Switch Settings



Input range selection is determined using Switches 1 through 5 of the 6 pole DIP switch (SW3) on the circuit board. The default setting is for 4 to 20 mA. Other ranges can be selected as illustrated below.

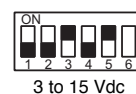
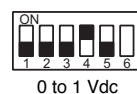
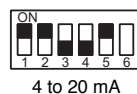

Stroke length is determined using Switch 6 of the 6 pole DIP switch (SW3) as illustrated below.

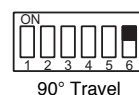
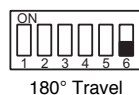

High Torque Actuator w/Controller

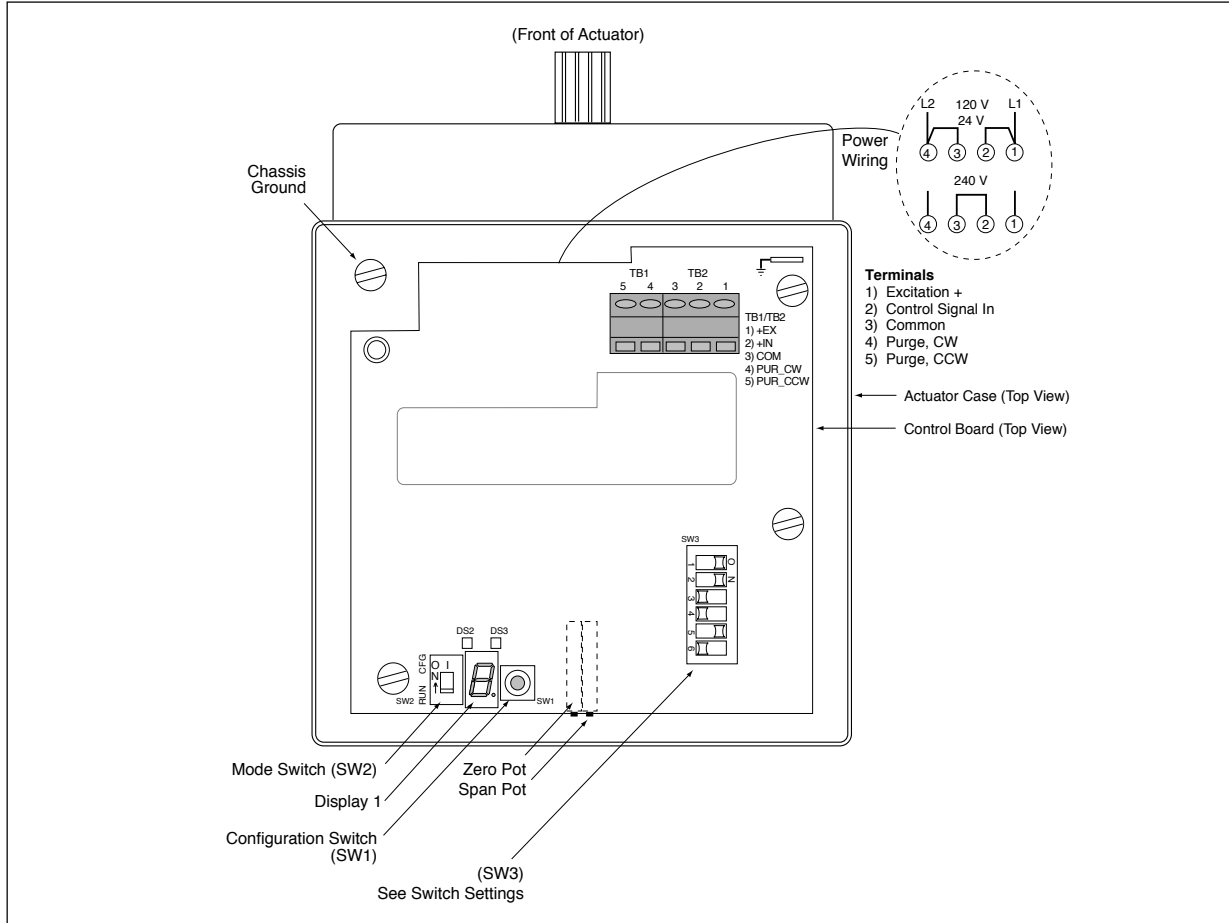

Figure 6. Controller board showing components used during setup and configuration

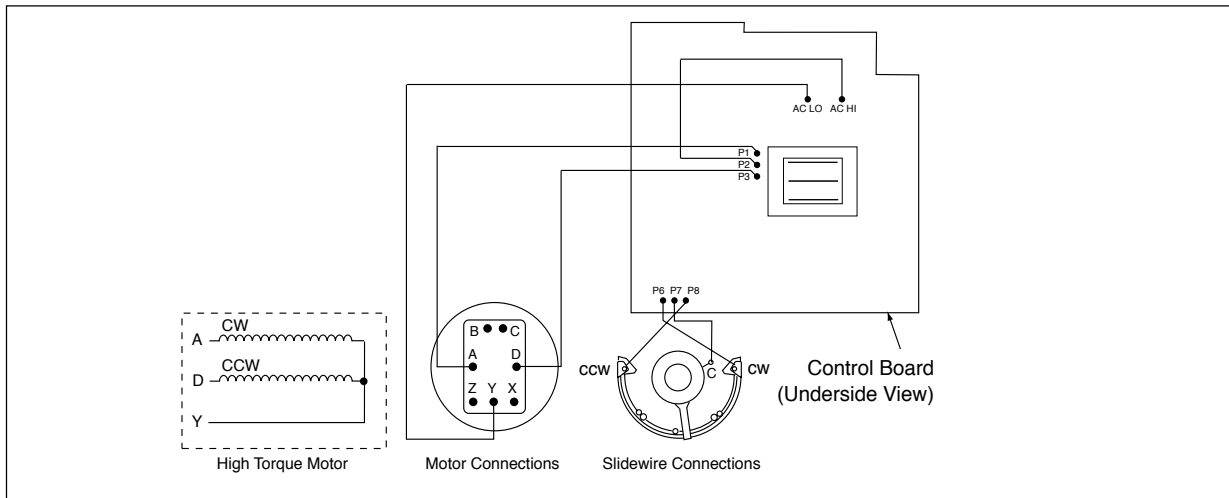

Figure 7. Motor and slidewire connections

High Torque Actuator w/Controller

Configuration Switch (SW1) is a momentary switch, active only when the controller is in the configuration mode.









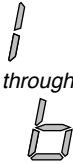

- When function codes are cycling, a single press will select the currently displayed code; press and hold will de-select it.
- When a function is selected, a single press will activate it for setting.
- When a function is activated, a single press will store the setting and return it to the selected state.

Mode Switch (SW2) must be in the CFG (“on”) position to carry out the configuration procedure; and in the RUN position for normal operation.

Display 1 (seven segment LED) permits selection and configuration of operating functions. Also shows the status and mode of the controller. See “Digital Display” table for details.

DS2 and DS3 indicators are active only during the configuration mode. The left LED is lit when a function is selected, and flashes when it is de-selected. The right LED is lit when a function is activated for setting, and flashes when the setting is saved (stored).

High Torque Actuator w/Controller

Digital Display		
Code	Configuration Mode	Run Mode
	Indicates configuration mode when mode switch first turned on. Flashing indicates no configuration data in RAM. Data will load to RAM when the controller is switched to the run mode. With data in RAM, configuration function codes sequentially display. Indicates CW shaft travel when configuration function code 1 is selected.	n/a
	Indicates CCW shaft travel when configuration function code 2 is selected.	n/a
	Hexadecimal digits 1 through b identify configuration functions. See Configuration Procedure section of this manual.	n/a
	Access to utility information and configuration.	n/a
	EE memory constants can be <i>erased</i> and replaced with default configuration values. Appears when power is applied to the controller while in the configuration mode and switch 1 is pressed; default values will be written to EE memory when the controller is switched to run mode.	n/a
	n/a	Configuration data being loaded into RAM. <i>Do not switch the controller to the configuration mode while loading data!</i>
	n/a	The controller is in the run mode and configuration data has been loaded into RAM. Active control will begin within five seconds.
	n/a	EE memory is being erased. <i>Do not switch the controller to the configuration mode while erasing data!</i>
	n/a	Data is being written to EE memory. <i>Do not switch the controller to the configuration mode while writing data!</i>
	n/a	Hexadecimal digits 0 through F indicate level of input signal, where: 0 = level (or less) of zero calibration. F = level (or greater) of span calibration.

High Torque Actuator w/Controller

6. Configuration

In this document, CW and CCW (clockwise, counter-clockwise) defines the rotation of the shaft viewed from the front of the actuator. Be aware of this distinction because during the configuration procedure you must observe the movement of the slidewire wiper – which is viewed from the rear of the actuator. Therefore, its rotation is reverse of the shaft rotation.

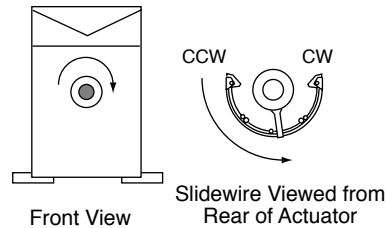

Note the position of the slidewire as the shaft turns clockwise.



CAUTION!

The shaft and the slidewire wiper are not mechanically latched. Therefore, it is possible to rotate the shaft beyond the limits of the slidewire. Always make sure the position of the shaft is correctly correlated to the position of the wiper before linking the actuator and valve or damper.

The following functions of the actuator controller can be configured:

Code Function and Description

1. **Maximum Travel Limit.** The maximum travel limit is defined as the position of the shaft when the slidewire wiper is at the desired maximum CCW position (90° or 180°, depending on the model). Normally, you will not have to adjust this parameter unless the actuator has been serviced or repaired. If the maximum travel position limit is set, go to the next configuration step.
2. **Minimum Travel Limit.** The minimum travel limit is defined as the position of the shaft when the slidewire wiper is at the full CW (0°) position. Normally, you will not have to adjust this parameter unless the actuator has been serviced or repaired. If the minimum travel position limit is set, go to next configuration step.
3. **Deadband**
4. **Dead time**
5. **Direction of Travel**
6. **Auxiliary Relay 1 (optional)**
7. **Auxiliary Relay 2 (optional)**
- 8, 9. **Control Input Zero. Control Input Span.** Control input is defined as the output of a primary controller, typically 4 to 20 mA. Function codes 3 and 4 permit you to calibrate the input circuit of the actuator controller to match the output of the primary controller.
- A. **Retransmitter Output Zero**
- b. **Retransmitter Output Span**

High Torque Actuator w/Controller

Configuration Procedure

Function 1 and 2 (Travel Limits)

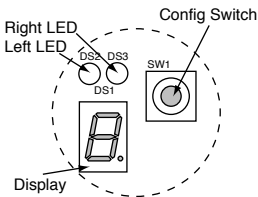

1. Select Function #1

When function code 1 appears, press/release the configuration switch (the Left LED comes on and function code 1 displays continuously).

2. Activate the Configuration Procedure

Press/release the configuration switch (DS3 comes on and function code 1 flashes).

3. Set the Configuration Value

Press/release the configuration switch until \curvearrowright (CW) appears on the display (DS3 is also on).

Press/hold the configuration switch until the shaft (wiper) reaches desired CW position; then release.

Press/release the configuration switch until \curvearrowleft (CCW) appears on the display (DS3 is also on).

Press/hold the configuration switch until the shaft (wiper) reaches desired CCW position; then release.

Press/release the configuration switch until \square appears.

Press/hold the configuration switch until \square flashes; then release.

4. Store the Configuration Value

Press/release the configuration switch (DS3 flashes five times; DS2 comes on and the function code displays continuously).

5. Move to Function 2

Press/hold the configuration switch until DS2 flashes; then release.

Return to step 3 to continue the configuration procedure, or move the mode switch to the run position to put the actuator in the normal operating state. See “Digital Display” table in the preceding section for an explanation of codes displayed while in the run mode.

Function 3 (Deadband)

The deadband setting requires two digits. Values range from 00 to 19 where 00 = 0.4% deadband, and 19 = 8% deadband. Set the least significant digit (LSD) position first; then set the most significant digit (MSD) position.

Press/hold the configuration switch until the desired LSD appears; then release.

Press/release the configuration switch to move to the MSD position.

High Torque Actuator w/Controller

Press/hold the configuration switch until the desired MSD appears; then release.

Press/release the configuration switch until **0** appears.

Press/hold the configuration switch until **0** flashes; then release.

Press/release the configuration switch (DS3 flashes five times; DS2 comes on and the function code displays continuously).

Function 4 (Dead time)

Dead time is a safety function that monitors the slidewire signal while the actuator is in motion. If the slidewire signal fails to change for a set amount of time, the motor is shut down. Dead time can be set from 01 to 99. A setting of 01 equals 250 milliseconds; a setting of 99 equals 13 seconds. The default setting is 12. Too low of a setting will cause the actuator to move in jerky steps. Larger settings may be required in cold weather or heavy load conditions.

Set the least significant digit (LSD) position first; then set the most significant digit (MSD) position.

Press/hold the configuration switch until the desired LSD appears; then release.

Press/release the configuration switch to move to the MSD position.

Press/hold the configuration switch until the desired MSD appears; then release.

Press/release the configuration switch until **0** appears.

Press/hold the configuration switch until **0** flashes; then release.

Press/release the configuration switch (DS3 flashes five times; DS2 comes on and the function code displays continuously).

Function 5 (Direction of Travel)

A setting of "1" causes CCW travel with an increasing signal; a setting of "2" causes CW travel with an increasing signal.

Press/hold the configuration switch until the desired value appears.

Press/release the configuration switch until **0** appears.

Press/hold the configuration switch until **0** flashes; then release.

Press/release the configuration switch (DS3 flashes five times; DS2 comes on and the function code displays continuously).

High Torque Actuator w/Controller

Function 6 and 7 (Auxiliary Relays)

Attach a signal source to the control input terminals (2 and 3). Adjust the source to the point on the slidewire at which the auxiliary switch is to change states.

Press/release the configuration switch (DS3 flashes five times; DS2 comes on and the function code displays continuously).

Function 8 and 9 (Control Signals)

Before attempting to calibrate the input signal be sure the input switches are set to match the output of the primary controller. Calibrating the input signal may require tweaking the potentiometers to adjust the slidewire wiper to the desired position for the zero and span input signals.

Attach a signal source to the control input terminals (2 and 3). Adjust the source to the desired level (zero or span). The wiper should move to the desired position on the slidewire. If necessary, adjust the potentiometer (R3 for zero; R1 for span) to bring the wiper to the desired position.

Press/release the configuration switch (DS3 flashes five times; DS2 comes on and the function code displays continuously).

Function A and b (Output Signals)

(reserved)

Function U (Information)

(reserved)

Return the mode switch to the run position to put the actuator in the normal operating state. See "Digital Display" table in preceding section for an explanation of the codes displayed while in the run mode.

Error Code Definitions

When an error occurs, the error code is flashed continuously until power is removed. The error code will continue to flash at a subsequent powerup unless the problem has been corrected. In some cases it may be necessary to use the powerup EEROM erase procedure to place the EEROM back into a known state.

Code	Definition
E0	Zero crossing fail detected
E1	Slidewire fail detected
E2	EEROM memory fail detected
E3	RAM memory init fail detected
E4	Travel configuration error detected (CW - CCW span must be $\geq 30\%$ of full 180 degree travel distance).
E5	Output calibration configuration error detected (output full scale must be greater than output zero by a minimum amount).
E6	Check sum error detected.
E7	Travel/stroke limits are set such that it is not possible to switch from 180 degree travel mode to 90 degree travel mode.
E8	Travel span that resulted in switching from 180 degree travel mode to 90 degree travel mode was less than 30% of the full 180 degree span.

High Torque Actuator w/Controller

Restoring Default Configuration Parameters using the EEROM Erase Procedure

The default configuration parameters can be restored using the following procedure:

1. Turn off power to the actuator converter.
2. Set slide switch SW2 to the CFG (ON) position.
3. Depress the SW1 pushbutton and hold in the depressed position.
4. Turn on power to the actuator converter while continuing to hold SW1 in the depressed position.

Display DS1 will show the following “character”:



LEDs DS2 and DS3 will be on continuously.

5. Continue to hold SW1 in the depressed position until display DS1 changes from:



to a flashing “c”:



(this will take approximately 15 seconds)

6. After the “c” character begins flashing, release the SW1 pushbutton and then switch SW2 to the run position (OFF).
7. The display will show the following “character”:



(three horizontal bars)

The three bars will be shown for approximately ten seconds while the EEROM is being erased.

8. When the erasure is complete, the display will rapidly cycle through the following characters:



indicates that the default configuration data is being written to the newly erased EEROM (P = Programming EEROM).

High Torque Actuator w/Controller

IMPORTANT!

During the time that the display shows the three horizontal bars and the P character, SW2 should not be switched back to the CFG position nor should the power to the actuator be removed. If either of these should occur the data in the EEROM may be invalid. If they do occur, simply start a new erase/restore procedure to ensure the correct default configuration data is written to the EEROM.

- ⌞ indicates that the configuration data in the EEROM (in this case the newly restored default configuration data) is being loaded from the EEROM to the working RAM (L = Loading RAM).
- ⌞ indicates that the actuator is ready to enter run-time, active control mode (r = ready to Run converter).
- ◀ blinks when the converter is in the active run mode. The blink rate is roughly proportional to the error between the input signal and the shaft position. If the shaft position is nulled with the input signal the rate is about 1 Hz. The rate increases in proportion to the error between shaft position and the input signal requirement.

7. Mounting Dimensions

Dimensions shown in inches.
Multiply by 25.4 to get millimeters.

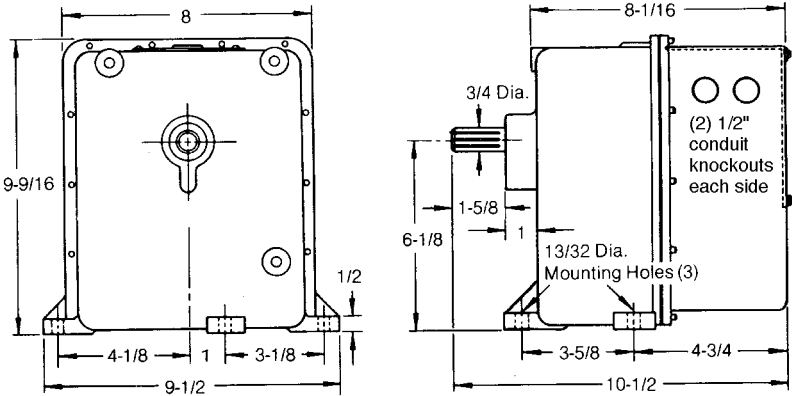

High Torque Actuator w/Controller

8. Retrofit Kits

The 71-1090-200 retrofit kit allows conversion of a standard EA70 series actuator with slidewire feedback to an analog input model.

Please note that the function of the internal auxiliary switch is lost when converting the actuator.

1. Remove the four screws holding the terminal block/switch plate assembly.
2. Remove the three screws connecting to the slidewire and wiper. Remove the slidewire.
3. Remove the round insulator from the feed-through connector. Unplug the harness.
4. Remove the terminal block/switch plate assembly. Retain the screws.
5. Install the new slidewire and harness. Refer to Figure 2 for details. Note that the figure shows the circuit board upside-down. The wires will not cross when the board is installed.
6. Plug the new harness into the feed-through connector. Install the round insulator.
7. If the actuator is a 240 volt model, remove links LK1 and LK2 from the circuit board (located adjacent to the triacs on the bottom of the board).
8. Plug the three harness connectors onto the receptacles on the bottom of the board as shown in Figure 2. The connectors have tabs to prevent plugging in backwards.
9. Configure the jumpers on the power terminal block for the proper line voltage.*
10. Install the board onto the actuator housing.
11. Installation is complete.

The board is pre-calibrated for 4-20 mA input. However, the firmware end-of-travel limits may have to be adjusted due to variations in slidewires. Connect a 4-20 source and check the travel. Use the configuration procedure for Functions 1 and 2 if adjustment is necessary.

*Do not lock down the safety cover of the terminal strip until final installation. The safety cover locking tabs grip firmly and it will be necessary to remove the circuit board to get them unlocked.



Barber-Colman Company
Industrial Instruments Division
1354 Clifford Avenue
P.O. Box 2940
Loves Park, IL U.S.A. 61132-2940

Telephone +1 815 637 3222
Facsimile +1 815 877 1195
<http://www.barber-colman.com>

An Invensys company