

For use with VB-7000 and VB-9000 Valve Bodies from Barber-Colman, and other commercially available rotary valve shaft bodies with crank arms for HVAC and combustion air dampers.

Used for two position, floating, and proportional control of dampers and valves in industrial applications. Typical applications are heat treat furnaces, ovens, heat recovery systems, water or oil cooling systems.

## Features

- **Proportional Actuators with Built-in Feedback Potentiometers**
- **120 Vac and 240 Vac Models Available**
- **Die Cast Housings with Four 1/2" Conduit Openings**
- **Oil Immersed Motor and Gear Train**
- **SPDT Auxiliary Switch Standard**

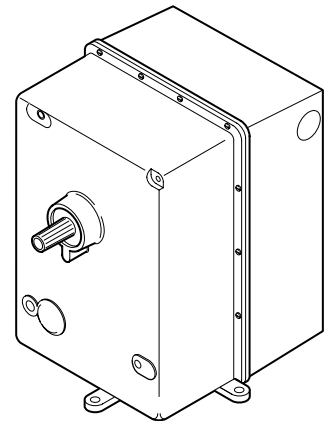

## 1. Introduction

These actuators meet the requirements of both damper control and valve control applications where it is desirable to move the load in either direction, or to stop it at any point in the stroke. All models contain feedback slidewires for true position-proportional control.

Actuators are shipped without mounting hardware or linkage. In damper applications, crank arms, connectors, link rods and mounting brackets will be required. In valve applications, valve bodies and AV type linkages will be required.

Before installing the actuator, look for bent or broken parts or oil leaks. Actuators should be connected to a power supply to check operation prior to installation.

All standard actuators include a 100 ohm feedback potentiometer. The active winding of the potentiometer is either 180 or 90 angular degrees, as defined by the model number.



# High Torque Actuators

## 2. Specifications

### Actuator Inputs

Input Control Signals: Refer to the actuator model number for input control signal capability of your specific actuator model.

Floating Control: Requires one SPDT switch with center off position, or two SPST contacts, rated for 2 amps @ 120 Vac, 1 amp @ 240 Vac.

Two Position: SPDT requires snap acting switch rated for 2 amps @ 120 Vac (no center off position). SPST can be used with certain spring return actuators. Switch must be rated to handle actuator power requirements.

Current/Voltage/

Potentiometer: Requires Model 658 or Model 659 position converter. See model number for ranges.

Connections: Coded screw terminals.

### Actuator Outputs

Power Requirements: Refer to the actuator model number to determine power requirements.

Torque: Refer to the actuator model number to determine torque rating.

Stroke: Refer to the actuator model number to determine degrees of rotation.

Auxiliary Switch:	<u>Electrical Rating</u>	<u>120 Vac</u>	<u>240 Vac</u>
	Running	5.8 amps	2.9 amps
	Locked Rotor	34.8 amps	17.4 amps
	Non-inductive	12	6

Note: Damper ratings are nominal and based on standard (not low leakage) at 1" (25.4 mm) W. C. differential pressure across the damper in the closed position and 2,000 FPM (ten m/s) fully open.

### Environment

Ambient Temperature Limits: Shipping and storage: -40°F to 160°F (-40°C to 71°C)  
Operating: -40°F to 130°F (-40°C to 54°C)

Humidity: 5 to 95% RH, non-condensing

Protection: NEMA 1. NEMA 4 for actuators with code 37 in field 7,8.

Power Consumption: 190 W

Maximum Duty Cycle: 50%

### Physical

Shipping Weight: 30 lbs.

# High Torque Actuators

## 3. Model Number

**Model E A**   -     -    -  -    
 Field No. 1 2 3 4 5 6 7 8 9 10 11 12 13 14 15

### Fields 1, 2. Model Series

EA - Base Model

### Fields 3, 4. Base Model

	Travel Limits	Time (seconds)	Torque (lbs/in; N-m)
71 -	90°	20	550; 62.5
72 -	180°	40	550; 62.5
73 -	90°	33	1100; 125
74 -	180°	65	1100; 125
75 -	90°	57	1300; 147.6
76 -	180°	115	1300; 147.6

### Fields 5, 6. Input

Note: Model 658A is a current to position converter;  
 Model 659A is a resistance to position converter.

	Input Signal	Converter Model
00 -	Contact	
11 -	4 to 20 mAcd	658A-00001
12 -	4 to 12 mAcd	658A-00002
13 -	12 to 20 mAcd	658A-00003
14 -	2 to 12 mAcd	658A-00004
15 -	2 to 7 mAcd	658A-00005
16 -	7 to 12 mAcd	658A-00006
19 -	Other, Special	658A-00008-000-X-XX**
31 -	Slidewire	659A-00000

The following codes are rain tight input converters mounted to the series EA. To order the series EA weather resistant, you must select cover option 37 (fields 7, 8).

#### Rain Tight Converters:

21 -	4 to 20 mAcd	658A-00011
22 -	4 to 12 mAcd	658A-00012
23 -	12 to 20 mAcd	658A-00013
24 -	2 to 12 mAcd	658A-00014
25 -	2 to 7 mAcd	658A-00015
26 -	7 to 12 mAcd	658A-00016
29 -	Other, Special	658A-00018-000-X-XX**
41 -	Slidewire	659A-00010

\*\*Consult factory.

### Fields 7, 8. Options

00 - None  
 37 - NEMA 4 weather resistant cover. This option must be included if rain tight converter is ordered.

Options 01 through 07 cannot be combined with rain tight converters.

- 01 - Two auxiliary SPDT switches
- 02 - Four auxiliary SPDT switches
- 03 - Rear shaft
- 04 - 100 Ω rear slidewire
- 05 - 100 Ω rear slidewire with two switches
- 06 - 1000 Ω rear slidewire
- 41 - One 100 Ω rear slidewire, weather resistant
- 42 - Two 100 Ω rear slidewires, weather resistant
- 43 - Three 100 Ω rear slidewires, weather resistant

### Field 9. Motor Voltage/Frequency

- 0 - 120 Vac 60 Hz
- 1 - 120 Vac 50 Hz (n/a with EA76)
- 3 - 240 Vac 60 Hz

### Fields 10, 11. Slidewire Transformer

- 00 - None
- 01 - Built-in 120 – 24 Vac (n/a with 658A or 659A)
- 02 - Built-in 240 – 24 Vac (n/a with 658A or 659A)

### Field 12. Feedback Slidewire

- 0 - 100 Ω
- 2 - 500 Ω
- 3 - 1000 Ω

### Fields 13, 14, 15. Special

- 0-00 - None

# High Torque Actuators

## 4. Installation



### CAUTION!

Disconnect the power supply (line power) before installation to prevent injury and equipment damage!

Make all connections in accordance with the wiring diagram and in accordance with national and local electrical codes.

*Use copper conductors only!*



### CAUTION!

Do not exceed the ratings of the devices!

Avoid locations where excessive moisture, corrosive fumes, or vibration is present!

**Note:** If, after wiring is completed, the actuator shaft does not turn in the desired direction, invert the leads to terminals 2 & 3, and to terminals 7 & 8 of the actuator terminal block!

Make all electrical connections in accordance with the job wiring diagram and in compliance with national and electrical codes. Power wire selection is shown below.

Power	AWG	Maximum Run
120 Vac	14	810' (247 m)
120 Vac	12	1275' (388 m)
120 Vac	10	2040' (622 m)
240 Vac	14	3340' (1018 m)

All units include a barrier which separates the line voltage terminals from the low voltage. Class I circuits must be used for connections to power terminals (L1, L2) and auxiliary switch terminals (1, 5, 6) (X, 2, 3). When numerous actuators are connected to one transformer, connect all L2 terminals to the same terminal of the transformer to prevent damage. Class II circuits may be used in the low voltage compartment to make connections to potentiometer terminals (4, 7, 8). Particular attention should be given to the job wiring diagram in regards to the location of the face jumpers and resistor connections to the actuators.

**Damper Mounting** Upright mounting preferred, but other positions acceptable. For longest life, minimum ambient temperature should not exceed -40°F (-40°C) and maximum temperature should not exceed 130°F (54°C)

**Linkage Assembly** One of the most common linkages is one in which the actuator stroke is 180° and the driven stroke is 90°.

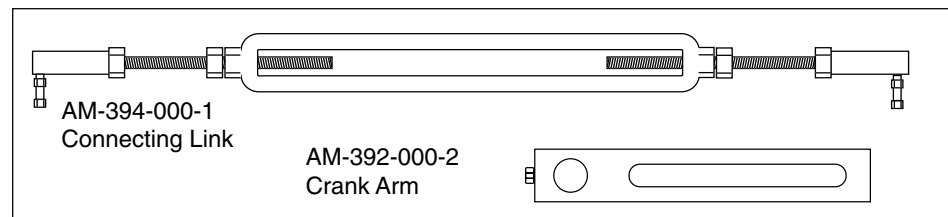

Figure 1. Linkage Components

# High Torque Actuators



## CAUTION!

The damper must not be mechanically stopped before the actuator has reached its electrical limit of travel or permanent damage can occur to the actuator!

1. During installation of the linkage assembly, the actuator should be powered and be able to be controlled manually.
2. Turn driven shaft back and forth to determine full closed and full open positions.
3. Mount crank arm on the driven shaft so that the location of the linkage connector in full closed and full open positions (points C1 and C) will fall on a straight line through the center of the actuator shaft. See Figure 2.

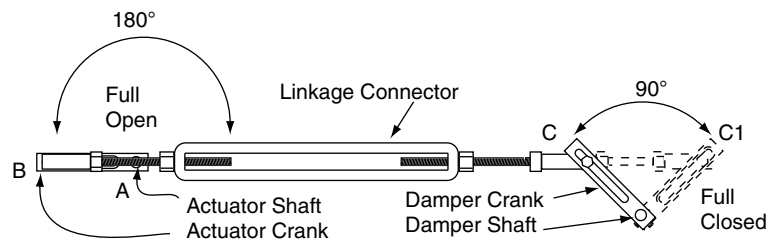

Figure 2. Linkage installed.

4. Secure one of the connecting links in the driven linkage connector.
5. Run actuator to the closed position and loosely set crank arm on actuator shaft. Do not tighten arm on shaft.
6. With crank arm still mounted loosely on actuator shaft, fasten linkage connector at about mid-position of crank arm slot. Move driven crank arm between full open and full closed positions. If radius of actuator crank is 0.707 times radius of driven crank, 180° movement of actuator crank will position driven shaft 90°.
7. Move driven crank arm to closed position and hold firmly in place. Secure crank on actuator shaft (point A) and linkage connector so that points A, B and C1 are in a straight line.
8. Check adjustment for proper operation by running actuator and driven shaft several times between open and closed positions. If driven crank arm does not provide tight closing, run actuator a few degrees away from closed position and reset connecting link in driven linkage connector. Driven crank arm will then provide closing under slight pressure.



## CAUTION!

If the crank arm does not provide proper travel, reset the linkage. Never attempt to turn the actuator shaft with a wrench or crank; this may damage the actuator!

# High Torque Actuators

## Valve Installation

Install all globe type valves with pressure under seat except where a flow direction arrow on the valve body indicates otherwise. For best control, three way valve applications should be designed to use mixing valves.

Preferred mounting is with the valve stem upright, but they can be mounted in other positions. For longest life, minimum ambient temperature should not exceed -40°F (-40°C) and maximum temperature should not exceed 130°F (54°C).

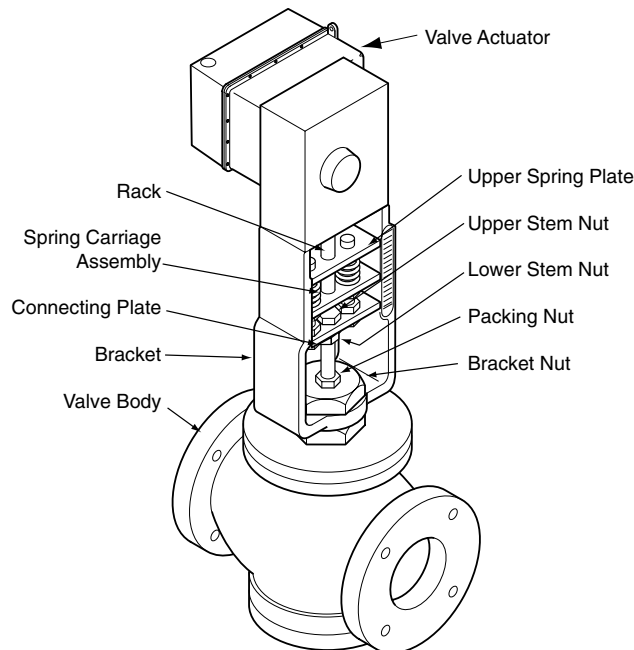

Figure 3. Typical Valve/Actuator Assembly Components

Valves are normally factory assembled and tested prior to shipment, but when necessary to assemble the valve, proceed as follows:

Note: Do not tamper with springs or spring carriage settings. These are critical and are factory set.

Note: Information for linkage kits to Barber-Colman Series VB-7000 and Series VB-9000 valves is available as accessory information in document 1322-IN-007-0-XX. Linkage to other valve bodies of similar stem stroke and collar size may be achieved by adjustment of these linkage kits.

### To remove actuator from valve assembly:

- 1) Run actuator to release stem compression.
- 2) Loosen four actuator mounting screws.
- 3) While supporting actuator, remove screws and disengage pinion from rack.
- 4) Remove pinion and washer from shaft.

### To mount pre-assembled actuator and linkage assembly on valve:

- 1) Run actuator to closed (stem down) position.
- 2) Remove bracket nut from valve.

# High Torque Actuators

- 3) Screw lower stem nut to bottom of threads on stem.
- 4) Place complete actuator and linkage assembly over valve stem and bonnet until stem extends through hole in connecting plate.
- 5) Rotate actuator and linkage assembly to desired position and secure with bracket nut.
- 6) Tighten lower stem nut against connecting plate.
- 7) Set compression as follows:
  - Loosen upper stem nut (if nut exists). Run actuator CW to closed position. Tighten lower stem nut against connecting plate, taking up all play in linkage.
  - Screw upper stem nut on stem 1/16" from connecting plate for compression on lower seat. (See Figure 4.)
  - Run actuator CCW until connecting plate is tight against upper stem nut. Secure lower stem nut against connecting plate.

## To Mount Linkage Assembly on Valve

- 1) Remove bracket nut from valve and screw lower stem nut down to bottom of threads on stem.
- 2) Place rack and spring carriage in bracket such that stem extends through connecting plate.
- 3) Align bracket so position indicator faces desired direction; then tighten bracket nut.
- 4) See actuator mounting instructions.

## To Mount Actuator on Linkage Assembly

- 1) Determine lift of valve by measuring total movement of stem.
- 2) Set shaft travel to correspond with valve lift. One degree of shaft rotation is equal to 0.011" of stem lift.
  - Insert screw driver through hole near front of terminal block and engage notched cam. Turning cam CW, as seen from front of actuator, increases shaft rotation. Each click of cam represents approximately 3° shaft rotation.
  - On three way valves only, add 5° rotation to total shaft travel to provide compression on upper seat.
- 3) With actuator in full CW (closed) position, rotate motor pinion until a pinion tooth lines up with center line of boss on actuator case (see Figure 5); slide washer and pinion on shaft. Mark this tooth for future reference.
- 4) Looking at front of linkage (position indicator side), rotate rack until teeth point to the left.
- 5) Align actuator so that marked tooth of pinion engages with third tooth space from top of rack. Mount actuator to linkage with the actuator mounting screws (4). Apply "Locktite," Grade CV to screw threads.

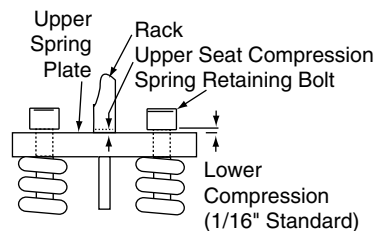

Figure 4. Compression

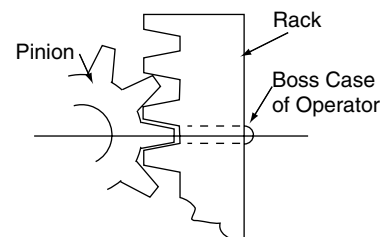

Figure 5. Rack and Pinion

# High Torque Actuators

## To Check Compression

Lower Seat: Run actuator to full closed (CW) position. Measure distance between head of spring retaining bolt and upper plate. (See Figure 4.)

Upper Seat (Three Way Valves Only): Run actuator to full open (CCW) position. Measure distance between bottom of rack and upper spring plate. To change compression on upper seat, adjust travel of actuator shaft. Standard spring compression is 1/16".

## Checkout

After the system has been installed, the following checks for proper operation may be used:

- 1) Set controller to call for process variable decrease. Check actuator rotation to insure correct direction.
- 2) Set controller to call for process variable increase. Check actuator rotation to insure correct direction.

Note: Looking at the front of the actuator with the shaft facing you, a 4 mAdc input signal will cause the actuator to rotate CW (120/240 V between terminals 2 and X). With a 20 mAdc input signal, the actuator will rotate CCW (120/240 V between 3 and X).

## 5. Run/Adjust

Actuator variations are shown in Figure 6. Line voltage proportional actuators without optional transformers are designed to be driven directly from position-proportioning temperature controllers, contacts from manual position switches, or current or resistance to position converters. Line voltage proportional actuators can be purchased with a built-in transformer to supply low voltage to a position indicator.

This actuator is driven by a tandem type motor with built-in automatic reset thermal overload protection which will stop operation if the motor temperature exceeds 150°F (66°C).

Power is applied to terminals L1 and L2. Directional control is achieved by jumping the L1 terminal to either terminal 2 (CW) or 3 (CCW). Avoid connecting terminals 2 and 3 simultaneously. Control of two actuators in tandem is accomplished by using a current or resistance to position converter (Model 658 or Model 659).

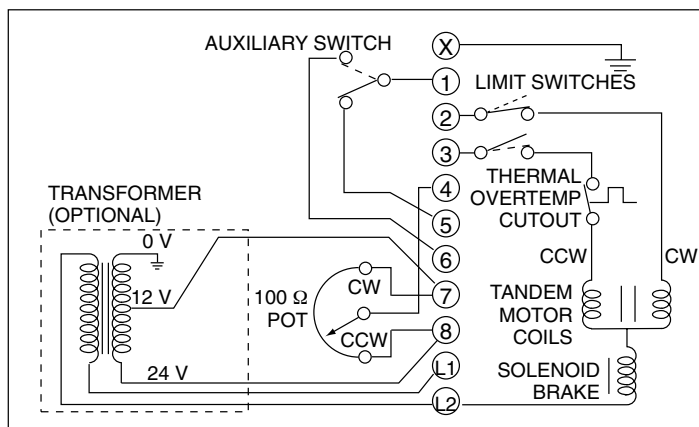

Figure 6. Internal Wiring

# High Torque Actuators

## 5.1 End of Travel Limit Switch Adjustment

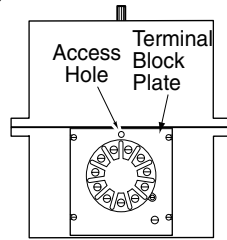

Figure 7. Top View

You can adjust the high end (CCW) of travel limit switch by inserting a screwdriver through the access hole in the terminal block plate to the notched cam near the front of the actuator.

Turn the cam clockwise – as seen from the front of the actuator – to increase the length of rotation; turn the cam counter-clockwise to decrease. Each click of the cam represents about 3° change. Attempting to adjust for more than the nominal rotation rating in degrees will cause the slidewire (potentiometer) wiper to exceed its travel end limits and affect calibration. Different slidewires are furnished for 90° or 180° models.

The clockwise, low end of travel limit switch (middle switch) is fixed and cannot be field adjusted. If the actuator terminal block plate is ever removed, it is imperative that it be replaced in its original position. If this is not done, the clockwise limit switch setting may change slightly as the switches themselves are anchored to the underside of the terminal block plate. Rotation is stopped when the switch cam follower rides up a lobe of its cam.

On valve actuators, it is important that the plunger cam and indicator point straight down at the clockwise end of the actuator rotation. Minor adjustments in the clockwise limit switch can be made to accomplish this by loosening the top plate and shifting it slightly in the screw slots until the proper location is attained. After this is done, re-check CCW and auxiliary switch settings.

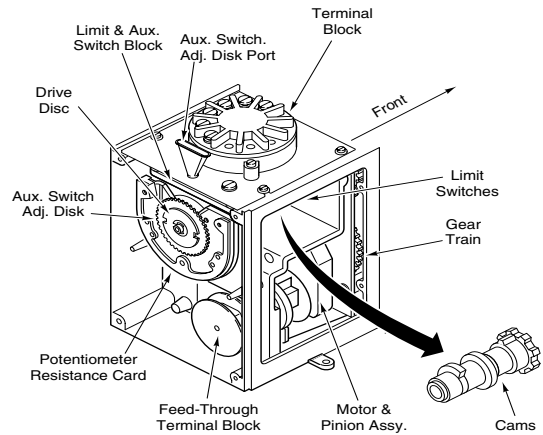

Figure 8. Exploded View

## 5.2 Auxiliary Switch Adjustment

The adjustable, built-in SPDT auxiliary switch is actuated by the cam nearest the back of the actuator. It is factory set to switch near the CW end of the actuator rotation. Terminal 1 of the common of the switch is made to terminal 5 from the CCW end of rotation until the switch point, then terminal 1 is made to terminal 6 for the rest of the stroke.

To adjust the switch point of the auxiliary switch, follow the steps shown below.

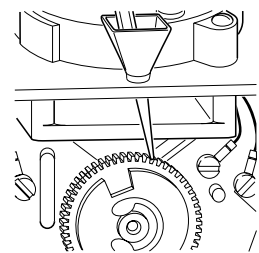

Figure 9. Adjusting Auxiliary Switch

Note: If, through mis-adjustment or damage, actuator travel has been increased beyond 180°, the auxiliary switch may, depending on its switch point, operate twice in a given stroke.

# High Torque Actuators

1. Remove the top cover of the actuator.
2. The actuator should be powered and positioned to desired point in actuator stroke for the auxiliary switch to operate.
3. The access hole for the auxiliary switch adjustment is located in the terminal plate of the actuator, near terminal 1.



## **CAUTION!**

**Disconnect the power to the actuator at the power terminals (H and G or L1 and L2) plus the auxiliary switch terminals (1, 5, 6). More than one disconnect may be required!**

4. Turning the cam CW (as seen from the front of the actuator) causes switch action to occur closer to the CCW end of travel. Each click of the cam represents about 3° change in actuator rotation.
5. After adjusting the cam, check the rotation by applying power from terminal X to terminal 3 to drive the actuator to its new CCW limit setting.
6. If the switching point is not what is desired, repeat steps 2 through 6 until desired results are obtained.

## 5.3 Potentiometer

All actuators include a potentiometer for use in proportioning rebalance circuits. Standard resistance is 100 ohms. The active winding of the potentiometer is normally spread over 180° or 90°, depending on the limits of the shaft rotation. The wiper arm of the potentiometer is connected to the main output shaft through a slip clutch arrangement. If the shaft travel is increased beyond the spread of the potentiometer winding, the wiper will not be damaged as it is restricted by a mechanical stop. When the shaft travels beyond the spread of the potentiometer winding, the wiper arm will cease to rotate when it hits the stop, but will instantly start moving in the opposite direction when the shaft reverses direction. This will cause the slidewire to give incorrect signals until the actuator is driven to both of its normal full CW and CCW travel limits.

## 6. Maintenance

Minimum maintenance is required since the motor and gear train are submerged in oil for continuous lubrication and cooling. If necessary to refill the actuator with oil (refill capacity 1 to 1-1/4 pints), always use immersion oil (available in quart containers: BYZP-195). For best performance, oil level – with actuator upright – should be up to the edge of the oil fill hole which is located in the front case of the actuator.

# High Torque Actuators

## 7. External Wiring

### Current Converter and Resistance Converter Wiring

**Model 658** Using the connections shown in the table below, increasing input causes CCW actuator rotation. To reverse actuator rotation, invert leads at actuator terminals 7 & 8, and 2 & 3.

A special option (65 or 66 in fields 14, 15 of the converter model code) is available on Model 658A that provides an extra (white) wire for activation of the purge option used on a burner control. A dry contact closure between the purge wire and the input + (red) wire will drive the actuator full open to provide 100% flow for air purge of a gas burner. Converters with special option 65 are wired for mounting on the left side of the actuator; converters with option 66 are wired for the right side of the actuator.

**Model 659** Using the connections shown in the table below, CW rotation of slidewire (or potentiometer) causes CW actuator rotation. To reverse actuator rotation, invert leads A & B.

Note: All references to direction of rotation are determined by looking at actuator output.

Converter		Actuator Terminal Numbers
Terminal Number Model 658/659B	Wire Color Model 658/659A	High Torque Series EA7X
4	Brown	4
7	Yellow	7
8	Orange	8
X	Red-Yellow	L1
2	Black-Blue	2
3	White-Blue	3
COM	Violet	L2
120 Vac	Blue	L1
240 Vac	Black-White	L1*
+	Red	<b>Model 658:</b> Connect to positive output terminal of controller. (See purge option below.) <b>Model 659:</b> Connect to wiper of remote slidewire or potentiometer. (See below.)
-	Black	<b>Model 658:</b> Connect to negative output terminal of controller. <b>Model 659:</b> Not connected.
n/a	White	<b>Model 658A:</b> Purge option: Special 65 or 66), dry contact that closes to red lead.
*Check motor voltage rating		
<b>Remote Slidewire or Potentiometer</b> (with Model 659 Resistance Converter)		

## Position Control Wiring

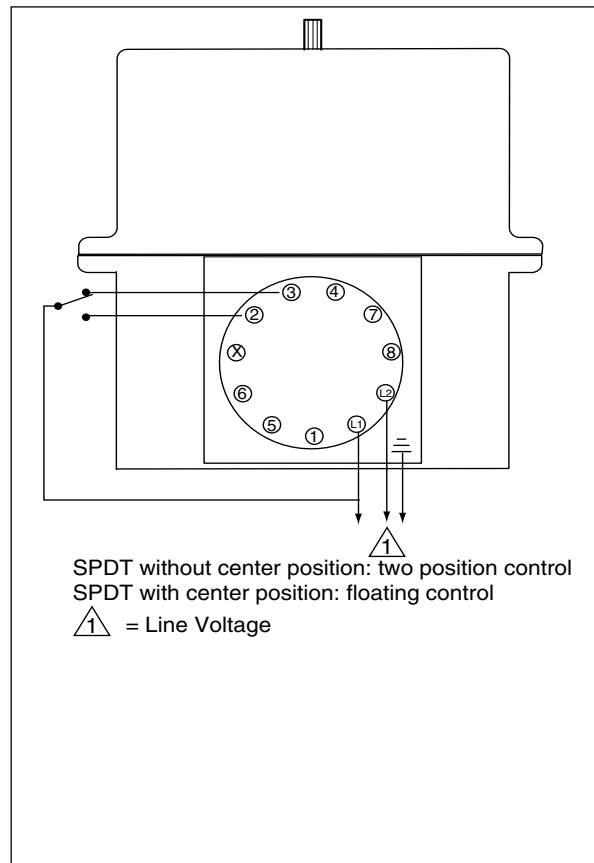
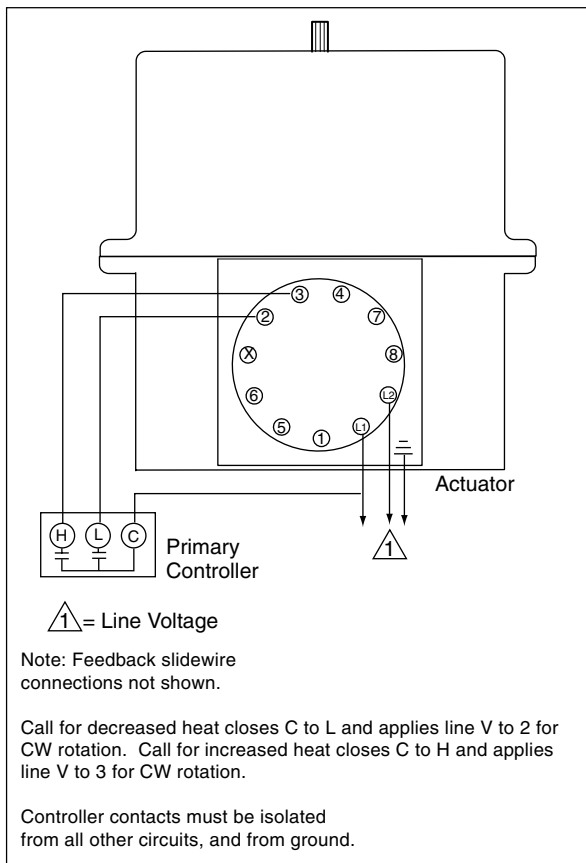

## 8. Mounting Dimensions

Dimensions shown in inches.  
Multiply by 25.4 to get millimeters.

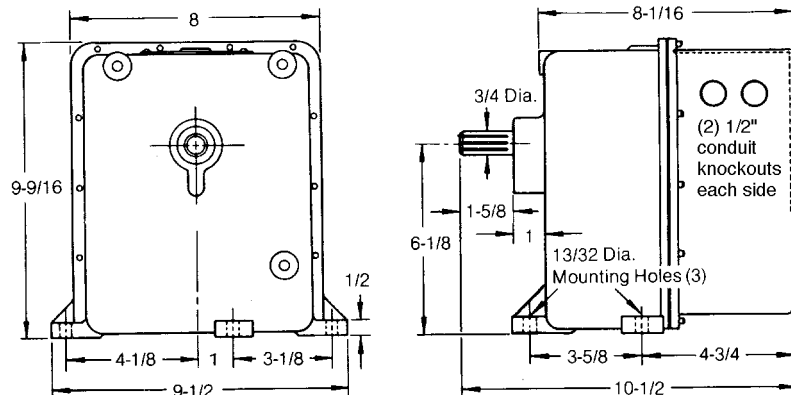

**Barber-Colman**  
1354 Clifford Avenue  
Loves Park, IL 61132-2940

Telephone +1 815 637 3222  
Facsimile +1 815 877 1195

<http://www.eurotherm.com>  
[info@eurotherm.com](mailto:info@eurotherm.com)



Copyright © 2003, 2004, 2005, Eurotherm Inc.

Action Instruments • Barber-Colman • Eurotherm Chessell • Eurotherm Controls