



Customer ABC

Building A
Spencer, IN

(Predictive Diagnostic Report)

York YS1 SBGM985790 July 20, 2005

Indianapolis, IN Branch

TABLE OF CONTENTS

I. Background Discussion

II. Explanation of Diagnostic Tests

For Each Machine Analyzed

III. Equipment Analyzed

IV. Written Analysis

Vibration Analysis

Motor Current Analysis

Oil Analysis

Refrigerant Analysis

V. Numerical Results

Vibration Analysis

Motor Current Analysis

Oil Analysis

Refrigerant Analysis

VI. Trend Results

Vibration Analysis

Motor Current Analysis

Oil Analysis

Refrigerant Analysis

VII. Vibration Measurement Locations Schematic

BACKGROUND DISCUSSION

This report combines the results from the following diagnostic tests:

Vibration Analysis
Motor Current Analysis
Oil Analysis
Refrigerant Analysis

The maintenance and monitoring recommendations are given based on the results of the tests performed. The results for each test are provided in sections V, VI, and VII of this report. The results for each machine are compared to the severity levels established by the Johnson Controls Inc. (JCI) Machine Database and are trended to determine the overall condition. All recommendations are reviewed by a certified Vibration Analyst. All test results and recommendations are stored indefinitely in the JCI Machine Database. Base any maintenance decision on the report recommendations, operating logs, maintenance history, other diagnostic tests, and qualified service representatives recommendations.

Definitions of the Overall Conditions:

Acceptable	Little or no deterioration in equipment condition is indicated, there is no cause for concern. Note for future analysis.
Alert	Rough, may be indicating a significant problem. Review maintenance history, operating logs, and a qualified service representatives recommendations. Monitor closely.
Alarm	Very rough, indicating a definite problem. Prepare for shutdown. Until repaired, run with caution, and monitor very closely.
Danger	Severe problem indicated. Failure is imminent. Notify operations. Shut down as soon as possible to avoid secondary damage.

EXPLANATION OF DIAGNOSTIC TESTS

VIBRATION ANALYSIS

The vibration measurements were collected on the machine casing at bearing locations in a vertical, horizontal, and axial direction using an accelerometer and vibration data collector. The vibration levels at frequencies associated with the major machine components (e.g. motor & compressor shafts, bearings, gears, impeller) were compared to the JCI Machine Database vibration severity levels. The vibration severity levels are based on the vibration characteristics of machines with similar mechanical configurations from the JCI Machine Database and on ISO Standard 10816. The vibration levels were compared to previous measurements to establish the trend and determine the final severity.

MOTOR CURRENT ANALYSIS

A current spectrum was collected from the motor. The current amplitudes of the line frequency and the motor slip sidebands were measured, and the dB difference was calculated. The dB difference is the difference between the line frequency and the motor slip sidebands current amplitudes. The dB difference was compared to the JCI Machine Database dB difference severity levels and to the previous measurements to establish the trend and determine the final severity.

OIL ANALYSIS

An oil sample was collected, and a spectromchemical analysis was performed using an emission spectrometer to identify wear and corrosion particles, contaminants, and metallic oil additives. The results are reported in parts per million (ppm). The viscosity test was performed in accordance to a Modified ASTM D445 (kinematic method) @ 40 degrees C and given in centistokes(cSt). The water content was determined by the Karl Fischer method and given in PPM. The Total Acid Number (TAN) was determined by a Modified ASTM D974 for wax free (WF) oils and by a Modified ASTM D664 for metallic antiwear/detergent (DTE type) oils.

REFRIGERANT ANALYSIS

A refrigerant sample was collected in accordance to EPA recovery guidelines. The sample was analyzed to determine the high boiling residue, total acid number, purity, particulates, chlorides, and moisture contents. The results were compared to Air Conditioning and Refrigerant Institute (ARI) standards and manufacturer specifications.

EQUIPMENT ANALYZED

CUSTOMER NAME: Customer ABC
SITE Building A
LOCATION: Spencer, IN
MAKE: York
MODEL: YS1
SERIAL NUMBER: SBGM985790
MEASUREMENT DATE:
Vibration Analysis July 20, 2005
Current Analysis July 20, 2005
Oil Analysis May 31, 2005
Refrigerant Analysis May 31, 2005



ANALYST

Feb-28-2006

DATE

OVERALL CONDITION AND RECOMMENDATIONS

Overall condition of machine: **Acceptable**

Recommendations:

Continue to monitor with predictive tests on a regular scheduled interval based on machine type, run-time, and criticality. Results from all diagnostic tests, including vibration analysis, oil analysis, and megger tests, should be used in conjunction with the machine's maintenance history and a qualified mechanic's recommendations to completely assess the condition of this machine.

WRITTEN RESULTS

Vibration Analysis

The vibration levels are at acceptable levels.

Current Analysis

The motor current measurements are at acceptable levels.

Oil Analysis

The oil measurements are at acceptable levels.

Refrigerant Analysis

The refrigerant measurements are at acceptable levels.

NUMERICAL RESULTS

Vibration Analysis

Component	Measurement Group	Amplitude	Measurement	Severity
	Operating Load	62 %	Vibration Operating Load	acceptable
Electrical	motor radial & axial	0.040 IPS	off-end horizontal	acceptable
Motor Shaft	motor rad & axial	0.016 IPS	off-end horizontal	acceptable
High-Speed Compressor Shaft	compr rad & axial	0.005 IPS	Inboard Axial	acceptable
Screw Rotors	compr rad & axial	0.091 IPS	Outboard Axial	acceptable
Low-Speed Compressor Shaft	compr rad & axial	0.003 IPS	Outboard Horizontal	acceptable
Motor Ball Bearing	motor axial	0.035 IPS	drive-end axial	acceptable
Compressor Bearings	compr rad & axial	0.025 IPS	Outboard Axial	acceptable

Current Analysis

Measurement Group	Amplitude	Severity
db Difference	51.8 dB	acceptable
Amps	130 Amps	acceptable

Oil Analysis

Measurement Group	Amplitude	Severity
Iron	2 ppm	acceptable
Lead	< 1 ppm	acceptable
Silicon	3 ppm	acceptable
Tin	< 1 ppm	acceptable
Zinc	< 1 ppm	acceptable
Total Acid Number	< 0.01 mg KOH / mg	acceptable
Moisture	60 ppm	acceptable
Viscosity	54.5 cST	acceptable

NUMERICAL RESULTS

Refrigerant Analysis

Measurement Group	Amplitude	Severity
Acidity	0.04 ppm HCL	acceptable
Moisture	< 1 ppm	acceptable
HBR	0.15 % vol	acceptable
Purity	99.85 % wt	acceptable

VIBRATION TREND RESULTS

Electrical motor radial & axial

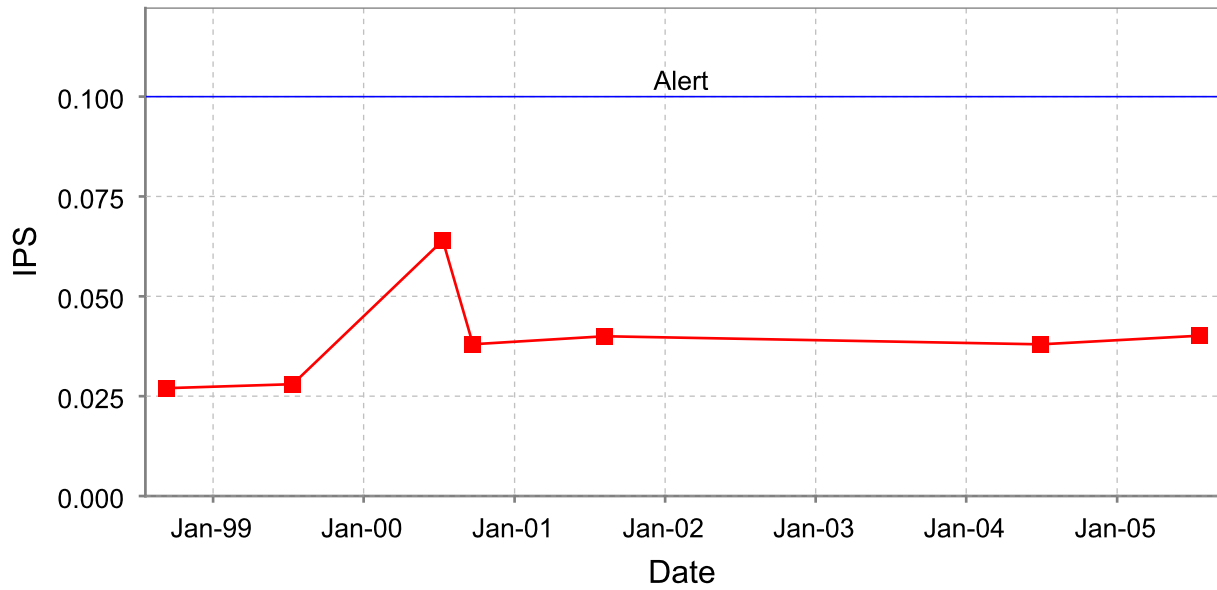

Motor Shaft motor rad & axial

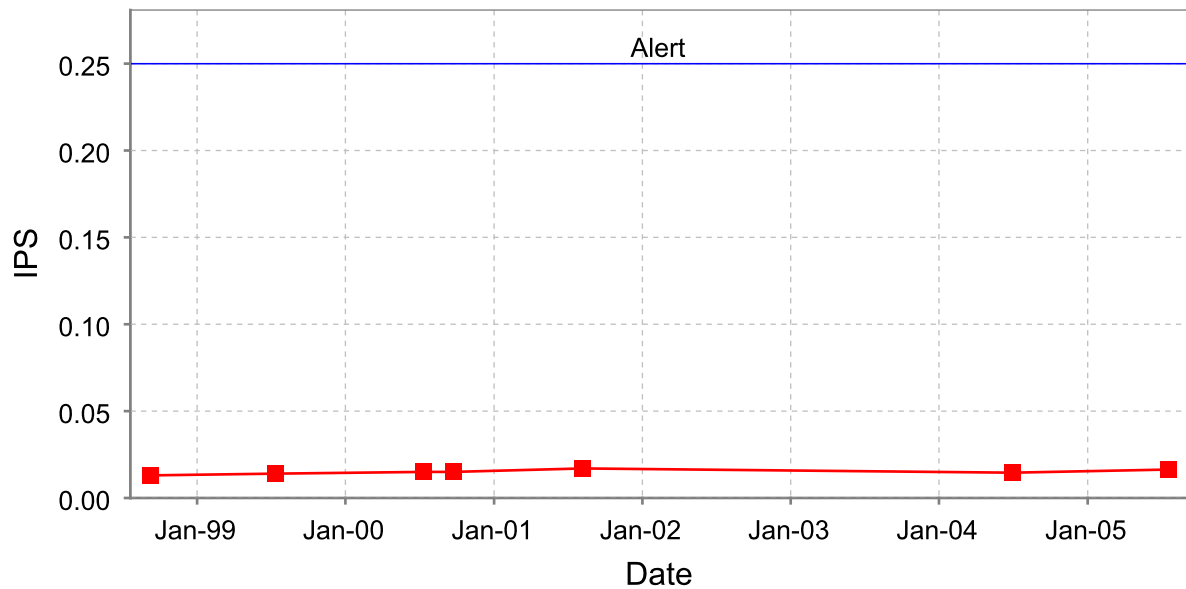

VIBRATION TREND RESULTS

High-Speed Compressor Shaft compr rad & axial

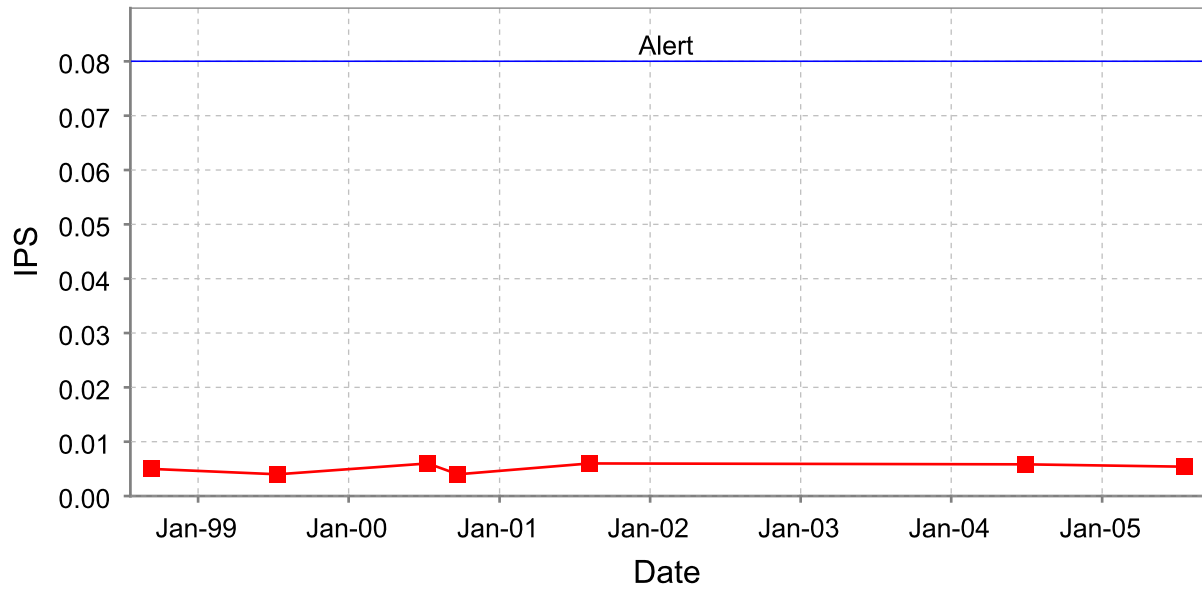

Screw Rotors compr rad & axial

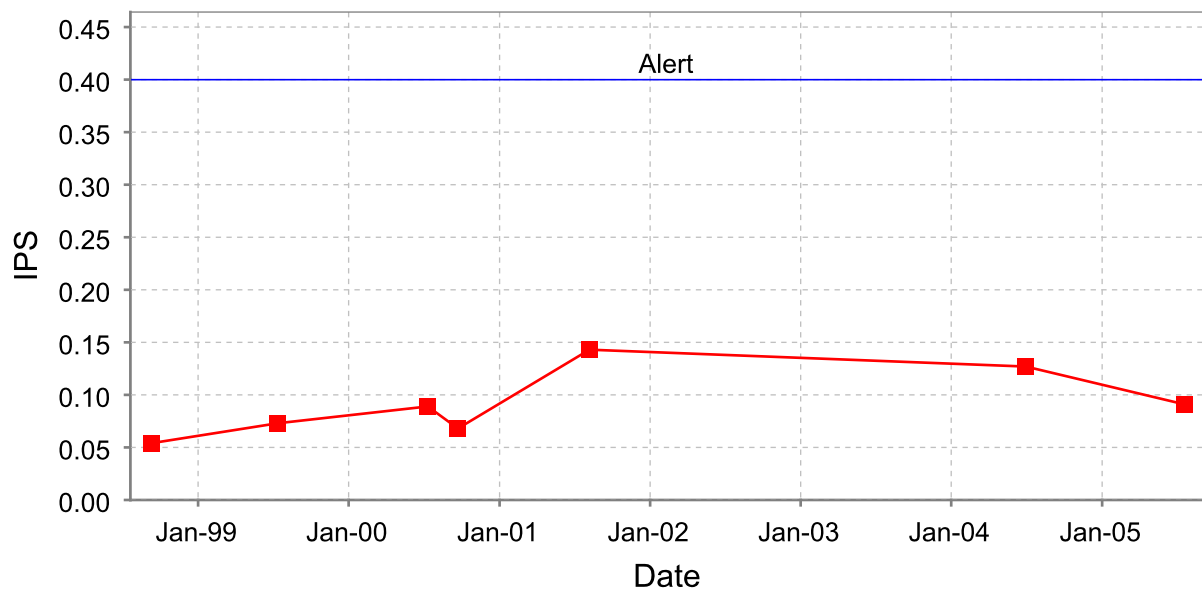

VIBRATION TREND RESULTS

Low-Speed Compressor Shaft compr rad & axial

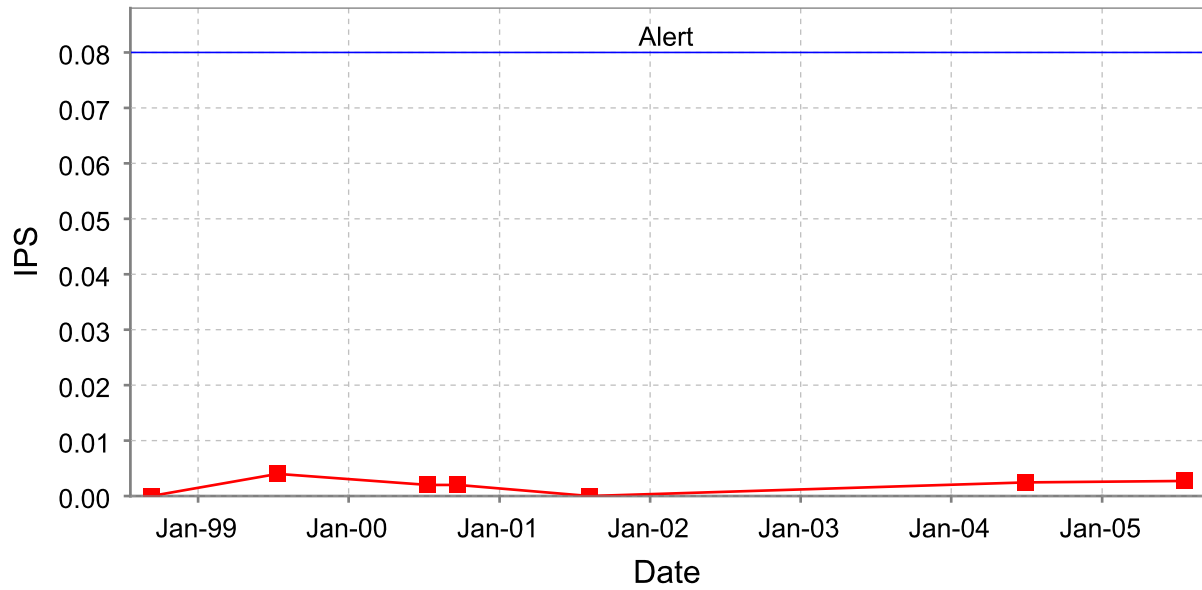

Motor Ball Bearing motor axial

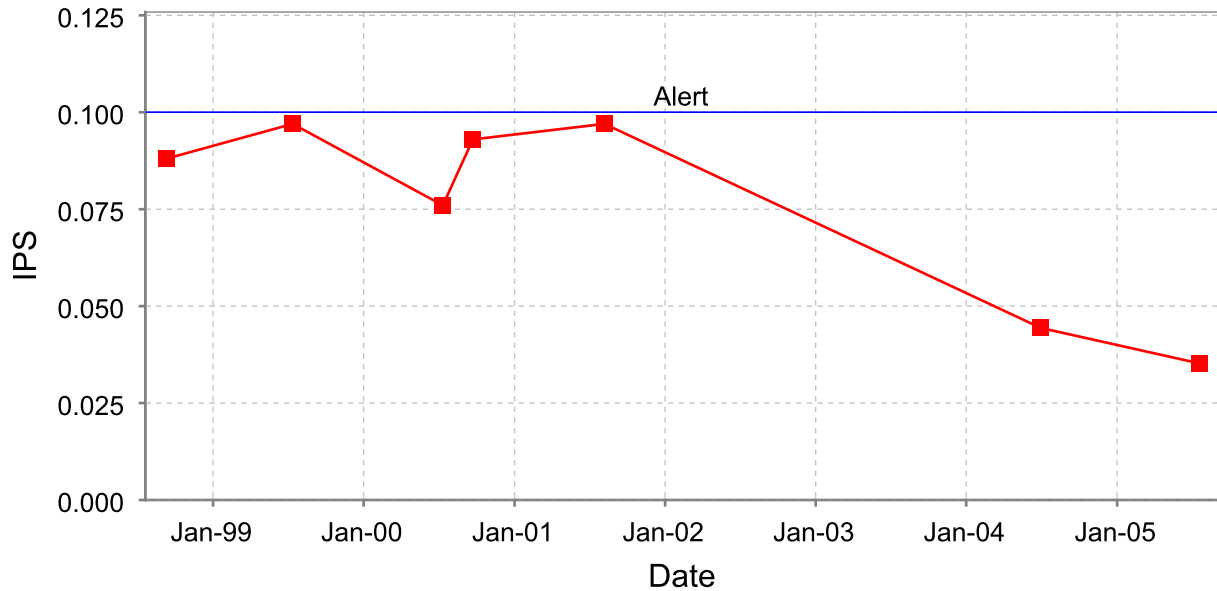

VIBRATION TREND RESULTS

Compressor Bearings compr rad & axial

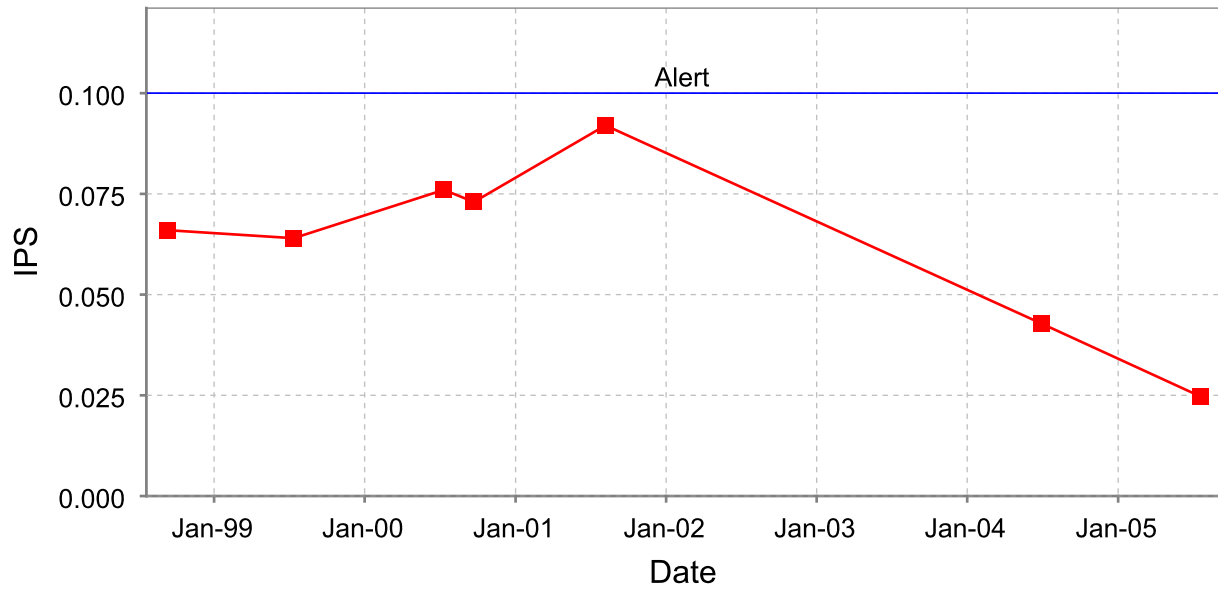

MOTOR CURRENT TREND RESULTS

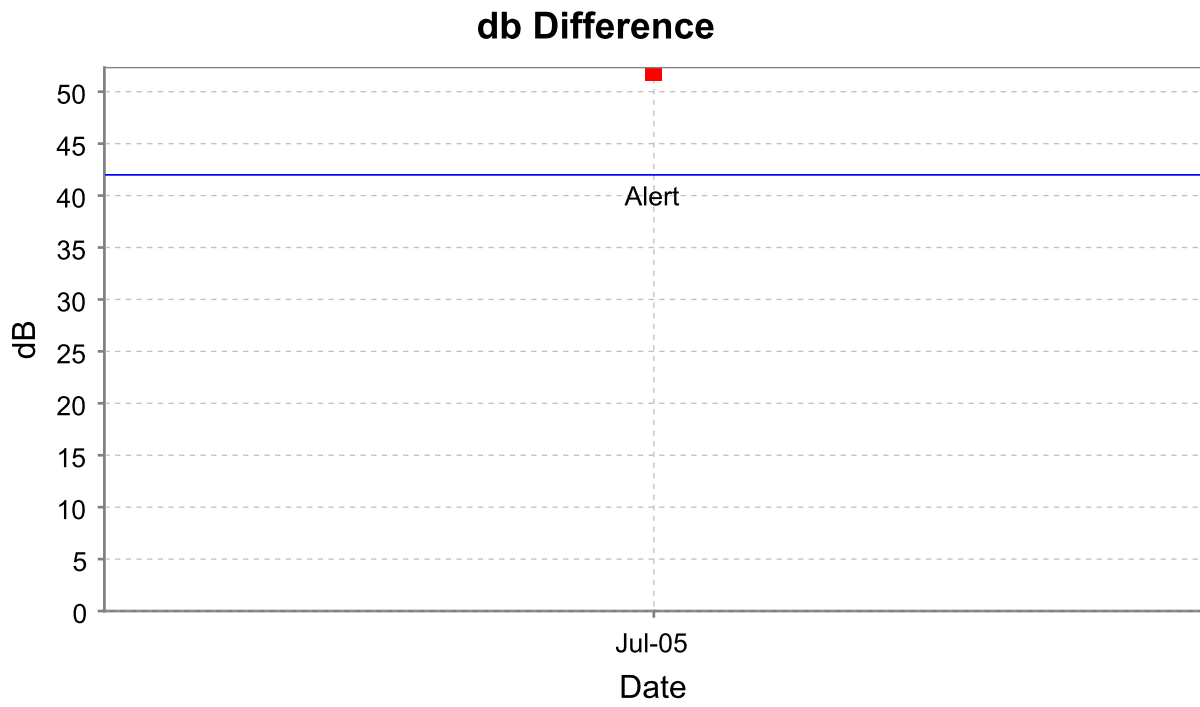

OIL TREND RESULTS

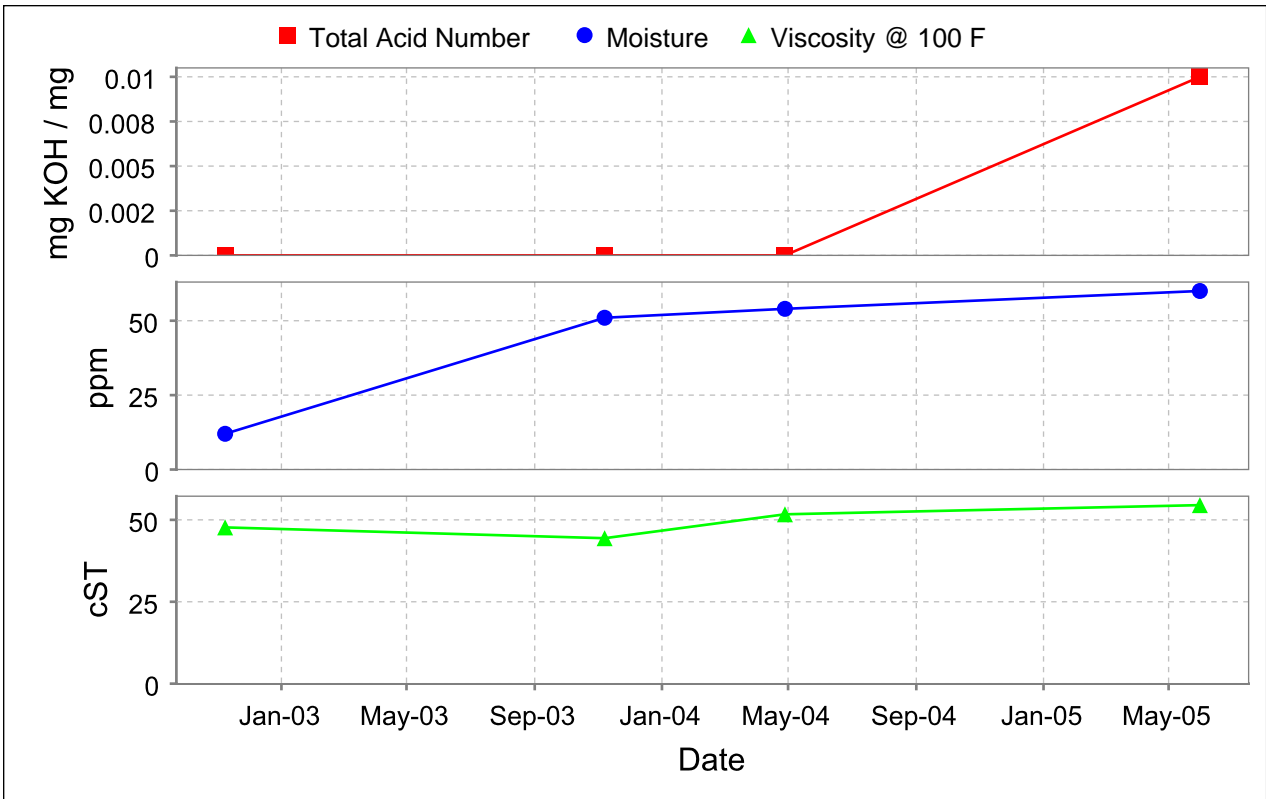
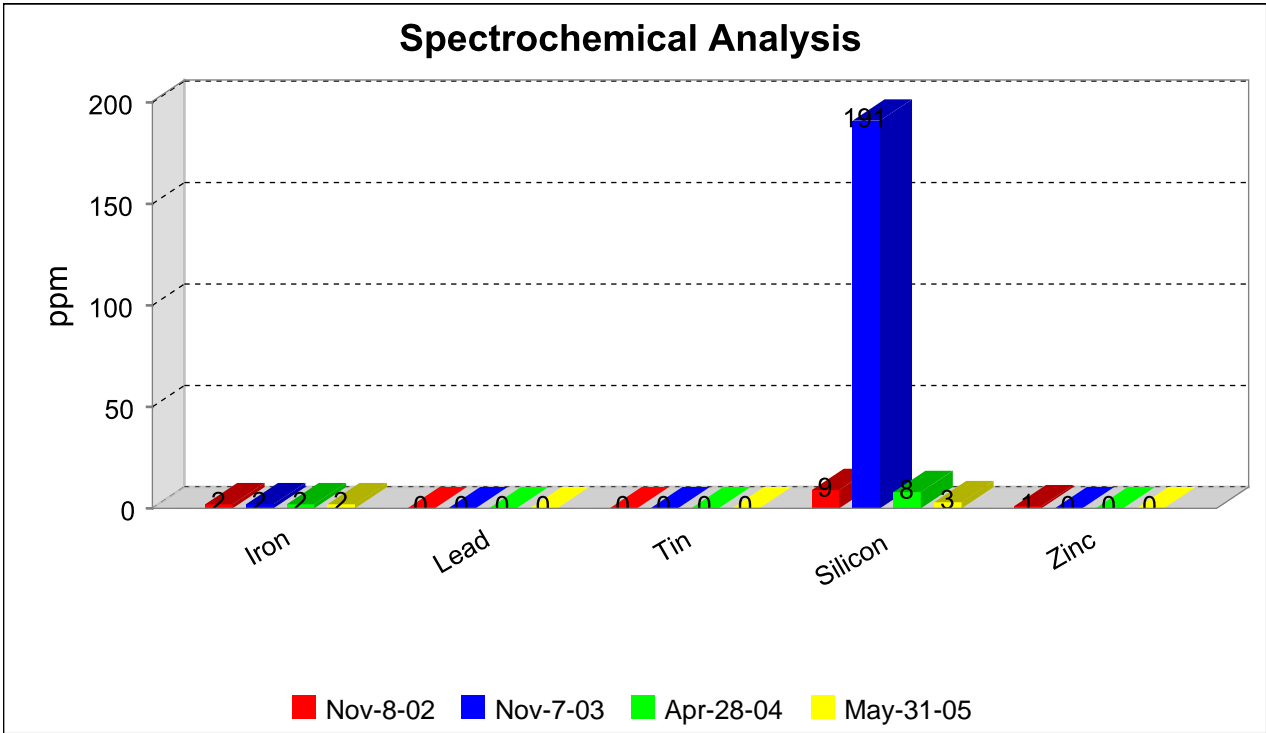

REFRIGERANT TREND RESULTS

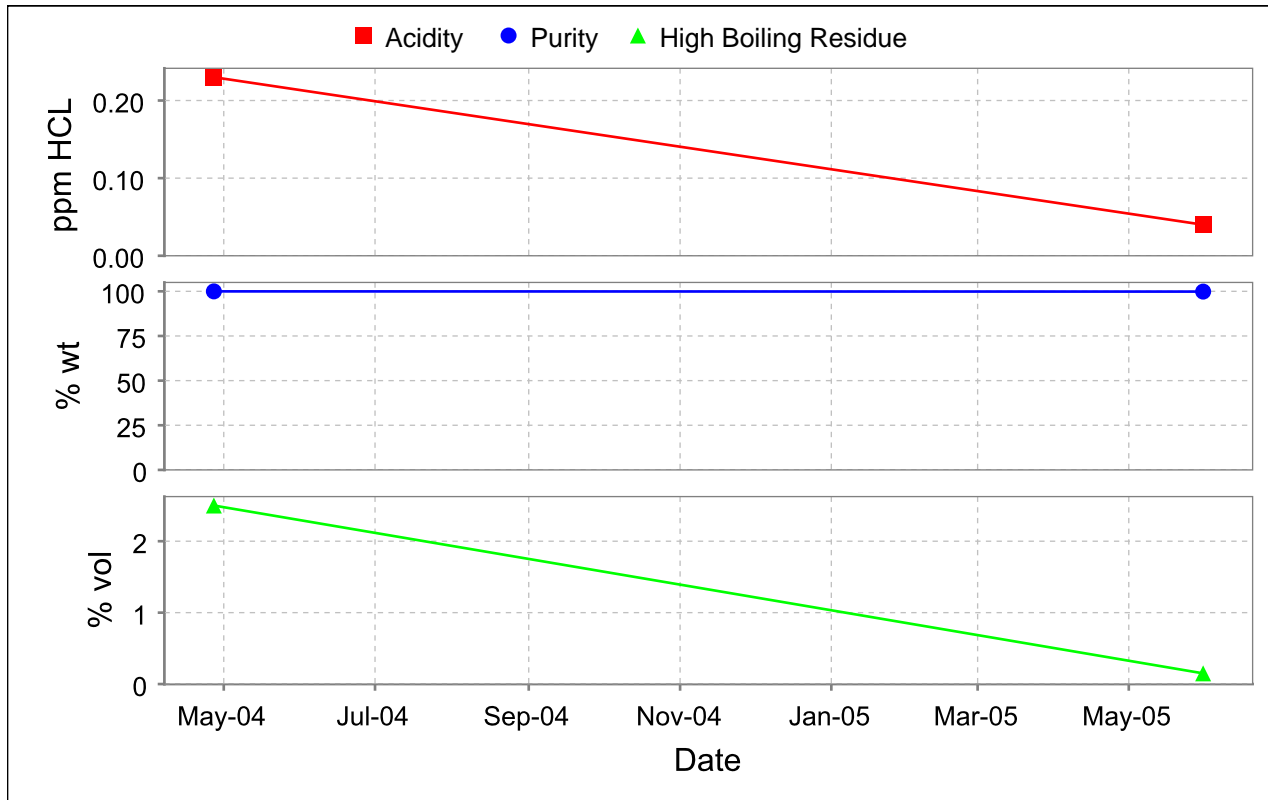

YORK YS1

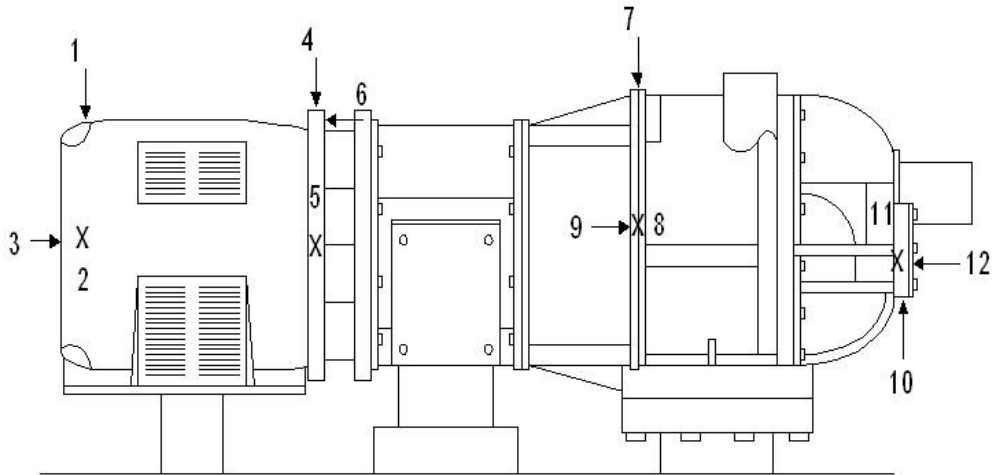

MEASUREMENT POINTS

- | | |
|----------------------|-----------------------|
| 1 - MOTOF Vertical | 7 - COMIB Vertical |
| 2 - MOTOF Horizontal | 8 - COMIB Horizontal |
| 3 - MOTOF Axial | 9 - COMIB Axial |
| 4 - MOTDR Vertical | 10 - COMOB Vertical |
| 5 - MOTDR Horizontal | 11 - COMOB Horizontal |
| 6 - MOTDR Axial | 12 - COMOB Axial |