



**Predictive and Proactive Maintenance • Getting the Most out of Your Budget**

**Benjamin L Hooks Central Library**  
Memphis, TN  
(Fan and Pump Diagnostics Report)

8/21/2013

**Vibration Specialist**

**Jacob Mulcahy**

**Memphis, TN Branch**

Vibration Analysis • Motor Current • Refrigerant Analysis • Oil Analysis • Eddy Current

## **TABLE OF CONTENTS**

- I. Analysis Background
- II. Equipment Summary
- III. Repair Recommendations
- IV. Recommendations for Improving Maintenance Practices  
Common Maintenance Practice Recommendations
- V. Detailed Analysis and Data
- VI. Machine Schematic Information
- VII. Appendix
  - Analysis and Assessment Process
  - Glossary of Vibration, Alignment, and Balancing Terms

## I. ANALYSIS BACKGROUND

The vibration measurements were collected on the machine casing at bearing locations in a vertical, horizontal, and axial direction using an accelerometer and vibration data collector. The vibration levels were compared to the JCI Machine Database vibration severity levels. The vibration severity levels are based on the vibration characteristics of machines with similar mechanical configurations from the JCI Machine Database and on ISO Standard 10816. The vibration levels were compared to previous measurements to establish the trend and determine the final severity.

## CONDITION DEFINITIONS

Condition Level	Vibration Analysis Indicates	Action
<b>Acceptable</b>	Little or no deterioration in equipment condition	There is no cause for concern. Note for future analysis.
<b>Alert</b>	Developing Problems	Monitor the vibration levels more frequently to establish a trend and to determine if repairs should be made during next shutdown.
<b>Alarm</b>	The machine is running rough.	Plan for a repair outage at the nearest opportunity. Until repaired, monitor closely.
<b>Danger</b>	A severe problem.	Correct problems immediately or at the first opportunity to avoid machine failure, unscheduled downtime, and secondary damage.

## II. EQUIPMENT SUMMARY

The overall condition of equipment can have a large impact on the operation of any facility. As the condition of the equipment improves, there are several factors that are affected:

- Operating Costs will decrease.
- Reliability will increase.
- Building Environment quality will increase.

### Overall Condition of Equipment

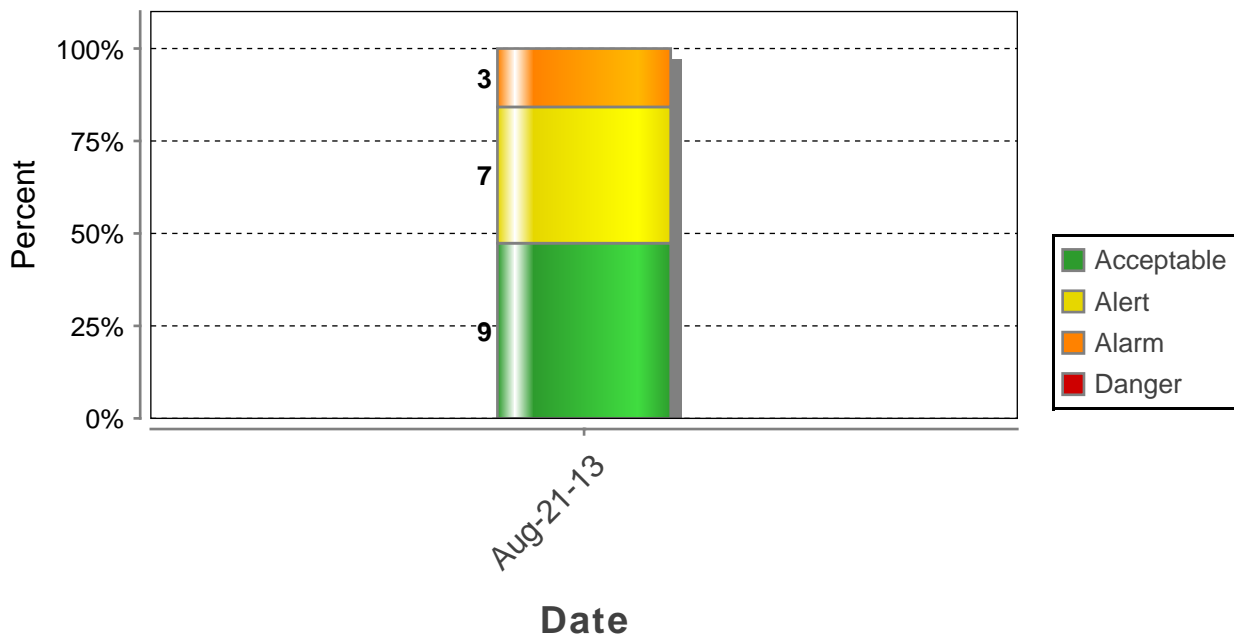

### Repair Costs

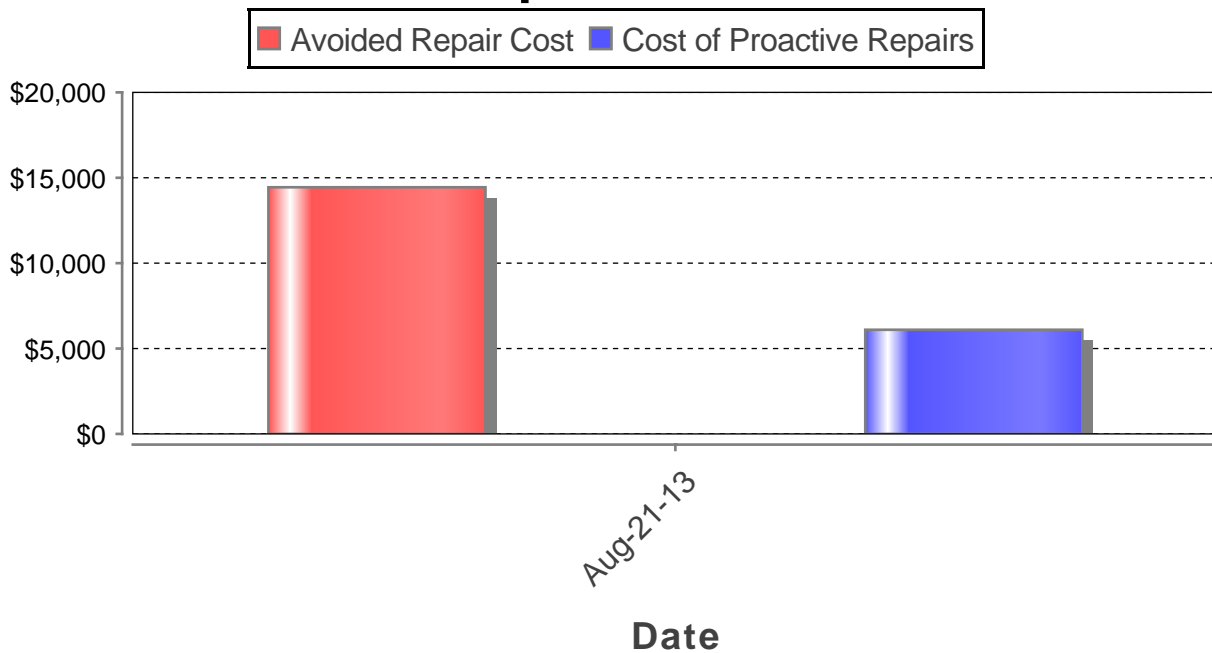

### III. PRIORITIZE REPAIR RECOMMENDATIONS

#### EQUIPMENT CONDITION

The following machine's condition is:

	Unit ID	Date of Collection	Machine Condition	Repairs Recommended
1	AHU-1	8/20/2013	Alarm	Replace the fan bearings.
2	AHU-2	8/20/2013	Acceptable	Continue to monitor on a regular basis.
3	AHU-3	8/20/2013	Alert	Check the alignment of the motor and fan sheaves.
4	AHU-4	8/20/2013	Acceptable	Continue to monitor on a regular basis.
5	AHU-5	8/20/2013	Alert	Check the alignment of the motor and fan sheaves.
6	AHU-6	8/20/2013	Alarm	Replace the fan bearings.
7	AHU-7	8/20/2013	Acceptable	Continue to monitor on a regular basis.
8	AHU-8	8/20/2013	Alarm	Check the alignment of the motor and fan sheaves. Check the motor sheave face and groove runout.
9	AHU-9	8/20/2013	Acceptable	Continue to monitor on a regular basis.
10	AHU-10	8/20/2013	Alert	Check the alignment of the motor and fan sheaves.
11	AHU-11	8/20/2013	Acceptable	Continue to monitor on a regular basis.
12	AHU-12	8/20/2013	Acceptable	Continue to monitor on a regular basis.
13	P-No ID	8/21/2013	Acceptable	Continue to monitor on a regular basis.
14	P-2	8/20/2013	Alert	Perform a precision shaft alignment.
15	P-3	8/21/2013	Acceptable	Continue to monitor on a regular basis.
16	P-4	8/20/2013	Acceptable	Continue to monitor on a regular basis.
17	P-5	8/20/2013	Alert	Perform a precision shaft alignment.
18	P-6	8/21/2013	Alert	Perform a precision shaft alignment.
19	P-11	8/21/2013	Alert	Monitor the possible motor bearing defect.

#### REPAIRS PERFORMED

**Esitmated Repair Costs** (The prices provided in this table are an example of pricing based on historical costs experienced and not a quotation for repair. The local Johnson Controls branch should be contacted for an actual written quote for repairs that may be more or less than what is provided below).

Machine	Problem	Estimate Cost of Proactive Repairs(CPR)		Run to failure		Avoided repair cost(ARC)
AHU-1 (< 30 hp)	worn/damged fan support bearing	\$1,400.00	replace fan support bearing	\$2,900.00	replace fan wheel, replace fan support bearing	\$1,500.00
AHU-3 (< 30 hp)	sheave misalignment	\$400.00	align sheaves	\$1,500.00	replace sheaves, align sheaves, Replace belts, correctly tension belts	\$1,100.00
AHU-5 (< 30 hp)	sheave misalignment	\$400.00	align sheaves	\$1,500.00	replace sheaves, align sheaves, Replace belts, correctly tension belts	\$1,100.00
AHU-6 (< 30 hp)	worn/damged fan support bearing	\$1,400.00	replace fan support bearing	\$2,900.00	replace fan wheel, replace fan support bearing	\$1,500.00
AHU-8 (< 30 hp)	eccentric sheave	\$500.00	replace sheaves	\$1,950.00	replace sheaves, Replace belts, replace motor bearings	\$1,450.00
	sheave misalignment	\$400.00	align sheaves	\$1,500.00	replace sheaves, align sheaves, Replace belts, correctly tension belts	\$1,100.00
AHU-10 (< 30 hp)	sheave misalignment	\$400.00	align sheaves	\$1,500.00	replace sheaves, align sheaves, Replace belts, correctly tension belts	\$1,100.00
P-2 (< 30 hp)	shaft misalignment	\$400.00	laser align	\$2,565.00	replace coupling, laser align, replace motor bearings, replace pump bearings & seals	\$2,165.00
P-5 (< 30 hp)	shaft misalignment	\$400.00	laser align	\$2,565.00	replace coupling, laser align, replace motor bearings, replace pump bearings & seals	\$2,165.00
P-6 (< 30 hp)	shaft misalignment	\$400.00	laser align	\$2,565.00	replace coupling, laser align, replace motor bearings, replace pump bearings & seals	\$2,165.00
		\$6,100.00		\$20,545.00		\$14,445.00

## IV. RECOMMENDATIONS FOR IMPROVING MAINTENANCE PRACTICES

### COMMON MAINTENANCE PRACTICE RECOMMENDATIONS

Does Problem Exist?	Problems	Possible Causes	Maintenance Practices
	Belt Problems	<ul style="list-style-type: none"> <li>• Belt too tight or loose</li> <li>• Damaged belt</li> <li>• Mismatched belts</li> <li>• Sheave misalignment</li> <li>• Eccentric sheave</li> </ul>	<ul style="list-style-type: none"> <li>• Perform vibration analysis for belt problems</li> <li>• Check belt for proper tension</li> <li>• Check belt for wear and damage</li> <li>• Replace all the belts at the same time with matched set.</li> <li>• Verify proper alignment</li> </ul>
	Eccentric sheave	<ul style="list-style-type: none"> <li>• Damaged or worn sheave</li> <li>• Cocked sheave</li> <li>• Variable pitched sheave</li> </ul>	<ul style="list-style-type: none"> <li>• Check sheave runout for eccentricity. Runout should be 5 mils or less.</li> <li>• During installation, uniformly tighten the taper lock while checking the face with dial indicator. If uniformly tightening the taper lock does not have any effect on the mounting problem, then remount the sheave.</li> <li>• Replace variable pitched sheave with fixed pitched sheave.</li> </ul>
	Sheave misalignment	<ul style="list-style-type: none"> <li>• Damaged sheave</li> <li>• Equipment arrangement</li> <li>• Variable pitched sheave</li> <li>• Excessive belt tension</li> </ul>	<ul style="list-style-type: none"> <li>• Perform alignment using a straight edge or a long string.</li> </ul>
	Bent shaft	<ul style="list-style-type: none"> <li>• Damaged or impaired shaft</li> <li>• Excessive heat</li> </ul>	<ul style="list-style-type: none"> <li>• Straighten or replace shaft. Check shaft runout, which should be 2 mils or less.</li> <li>• Excessive belt tension</li> <li>• Improper shaft repair</li> </ul>
	Cracked shaft	<ul style="list-style-type: none"> <li>• Perform vibration analysis for belt problems.</li> </ul>	<ul style="list-style-type: none"> <li>• Check belt for proper tension</li> </ul>
	Shaft misalignment	<ul style="list-style-type: none"> <li>• Damaged or worn shaft</li> <li>• Out of tolerance</li> <li>• Looseness problems</li> </ul>	<ul style="list-style-type: none"> <li>• Check coupling and shaft runout for wear. Runout should be 2 mils or less.</li> <li>• Inspect coupling for damages.</li> <li>• Perform precision shaft alignment</li> </ul>
	Bearing	<ul style="list-style-type: none"> <li>• Damaged or worn bearings</li> <li>• Over- or under-greased</li> <li>• Cocked or loose bearings</li> </ul>	<ul style="list-style-type: none"> <li>• Perform vibration analysis for bearing problems.</li> <li>• Properly lubricate the bearings. Follow OEM recommended intervals and quantity.</li> <li>• Install bearings properly per manufacturer's recommendations.</li> </ul>

**COMMON MAINTENANCE PRACTICE RECOMMENDATIONS (continued)**

Does Problem Exist?	Problems	Possible Causes	Maintenance Practices
	Soft foot	<ul style="list-style-type: none"> <li>• Damaged or worn frame</li> <li>• Improper mounting pad</li> <li>• Bent motor feet</li> <li>• Too many shims</li> <li>• Frame distortion</li> </ul>	<ul style="list-style-type: none"> <li>• Check for soft foot with shims or dial indicator. Soft foot should be 3 mils or less.</li> <li>• Replace many thin shims with fewer thicker shims.</li> </ul>
	Looseness	<ul style="list-style-type: none"> <li>• Loose mounting bolts</li> <li>• Structural looseness</li> <li>• Improper fit between component parts</li> <li>• Soft foot</li> </ul>	<ul style="list-style-type: none"> <li>• Perform vibration analysis.</li> <li>• Tighten all mounting bolts to prevent looseness or frame distortion.</li> <li>• Check for soft foot with shims. Soft foot should be 3 mils or less.</li> <li>• Inspect the frame for damages.</li> </ul>
	Frame distortion	<ul style="list-style-type: none"> <li>• Damaged or worn</li> </ul>	<ul style="list-style-type: none"> <li>• Check frame for damage.</li> <li>• Check for soft foot with shims. Soft foot should be 3 mils or less.</li> <li>• Repair frame.</li> </ul>
	Imbalance	<ul style="list-style-type: none"> <li>• Heavy spot</li> <li>• Dirt build-up on fan blades</li> <li>• Cracked hub on vane axial fan</li> </ul>	<ul style="list-style-type: none"> <li>• Perform fan balancing.</li> <li>• Inspect fan for dirt build-up on blades.</li> <li>• On vane axial fans, inspect hub for damages and loosenees.</li> </ul>
	Resonance	<ul style="list-style-type: none"> <li>• Loose mounting bolts</li> <li>• Damaged isolation springs</li> <li>• Cracked or damaged frame</li> <li>• Frame distortion</li> <li>• Insufficient support</li> </ul>	<ul style="list-style-type: none"> <li>• Perform bump test to determine the natural frequency.</li> <li>• Perform an ODS analysis.</li> <li>• Tighten all mounting bolts</li> <li>• Check isolation springs for damages</li> <li>• Add additional bracing.</li> <li>• Repair frame.</li> </ul>
	Air Flow problems	<ul style="list-style-type: none"> <li>• Variations in pressure or velocity which cause turbulence</li> <li>• Flow restrictions</li> </ul>	<ul style="list-style-type: none"> <li>• Adjust guide vanes for proper flow.</li> <li>• Check ductwork for plugged filter or coil.</li> <li>• Check for proper air balance.</li> </ul>
	Caviataion in pumps	<ul style="list-style-type: none"> <li>• Insufficient suction pressure</li> </ul>	<ul style="list-style-type: none"> <li>• Check for proper flow at the discharge.</li> <li>• Check for proper head, especially on the suction valve settings.</li> <li>• Prevent restrictions in the return.</li> </ul>
	Electrical problems	<ul style="list-style-type: none"> <li>• Phase imbalance</li> <li>• Loose connectors</li> <li>• Stator problem</li> <li>• Poor power quality</li> </ul>	<ul style="list-style-type: none"> <li>• Check motor for broken or corroded connectors.</li> <li>• Check all motor connections for a tight fit.</li> <li>• Check power quality</li> <li>• Check for soft foot with shims. Soft foot should be 3 mils or less.</li> </ul>

## **V. DETAILED ANALYSIS AND DATA**

Johnson Controls uses fan and pump vibration worksheets to document the analysis performed on each machine. This section includes these worksheets.

Additionally, we collect data (spectra) before and after repairs. Collecting data after repairs is just as important as collecting it before because we can offer you:

- Efficient correction of equipment problems to minimize disruption to operations.
- Verification that repairs were made to help you avoid future repair costs.
- A baseline for trending the equipment's condition to help you avoid unscheduled downtime.

Recommendations: **Replace the fan bearings.**

Condition: **ALARM**

Analyzed By: Jacob Mulcahy

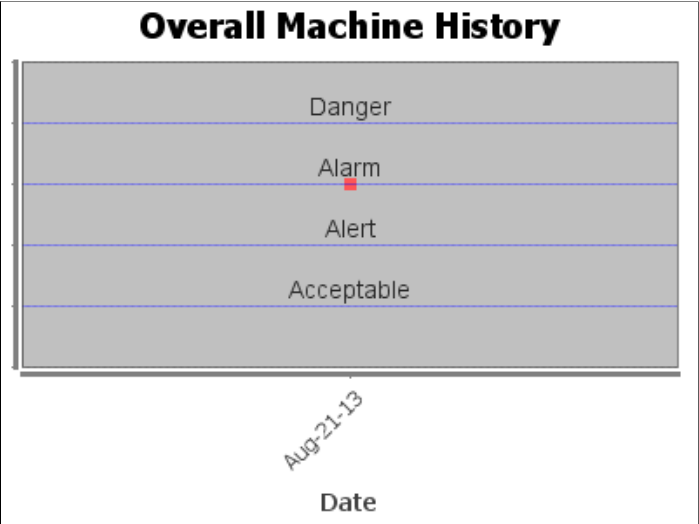
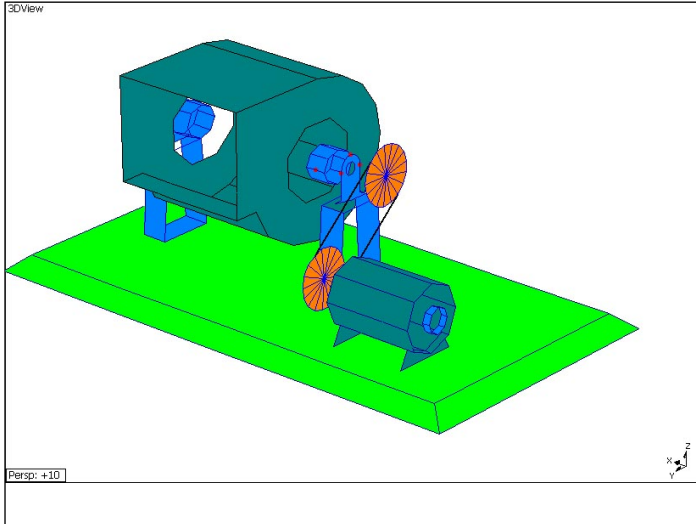

Recommendations

Replace the fan support bearings.

Diagnosis

The vibrations at a ball bearing defect frequencies indicate a problem with the fan support bearings.

**AHU-1 : Aug 21, 2013**

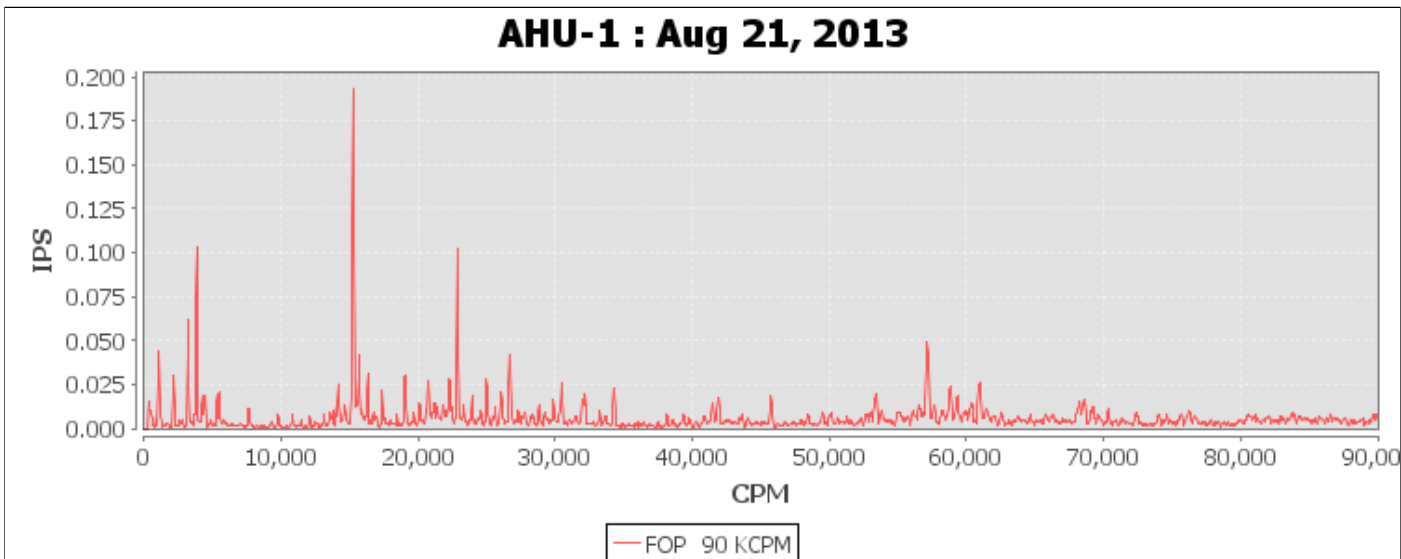

Recommendations: **Check the alignment of the motor and fan sheaves.**

Condition: **ALERT**

Analyzed By: Jacob Mulcahy

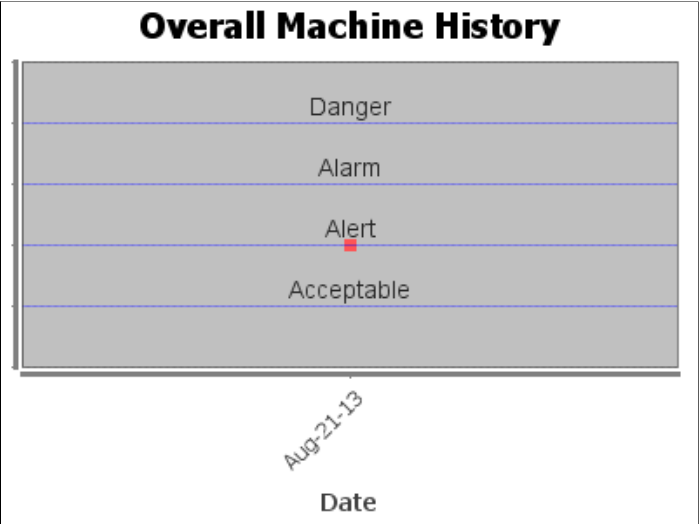
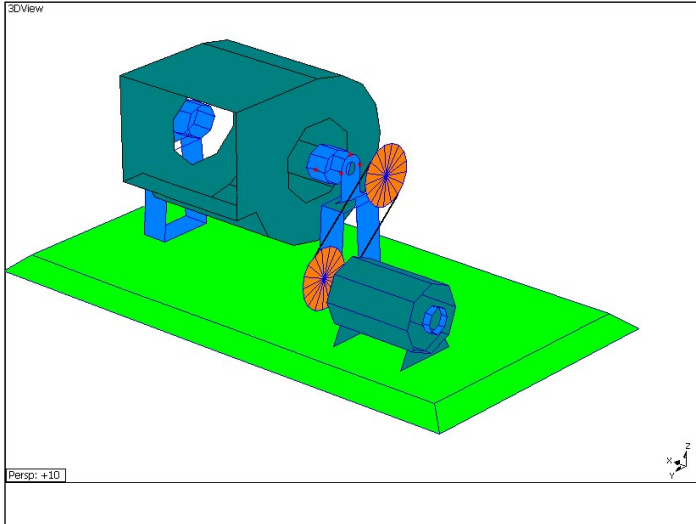

Recommendations

Check the alignment of the motor and fan sheaves.

Diagnosis

The vibration levels and harmonics of the fan turning speed indicate a possible sheave misalignment.

**AHU-3 : Aug 21, 2013**

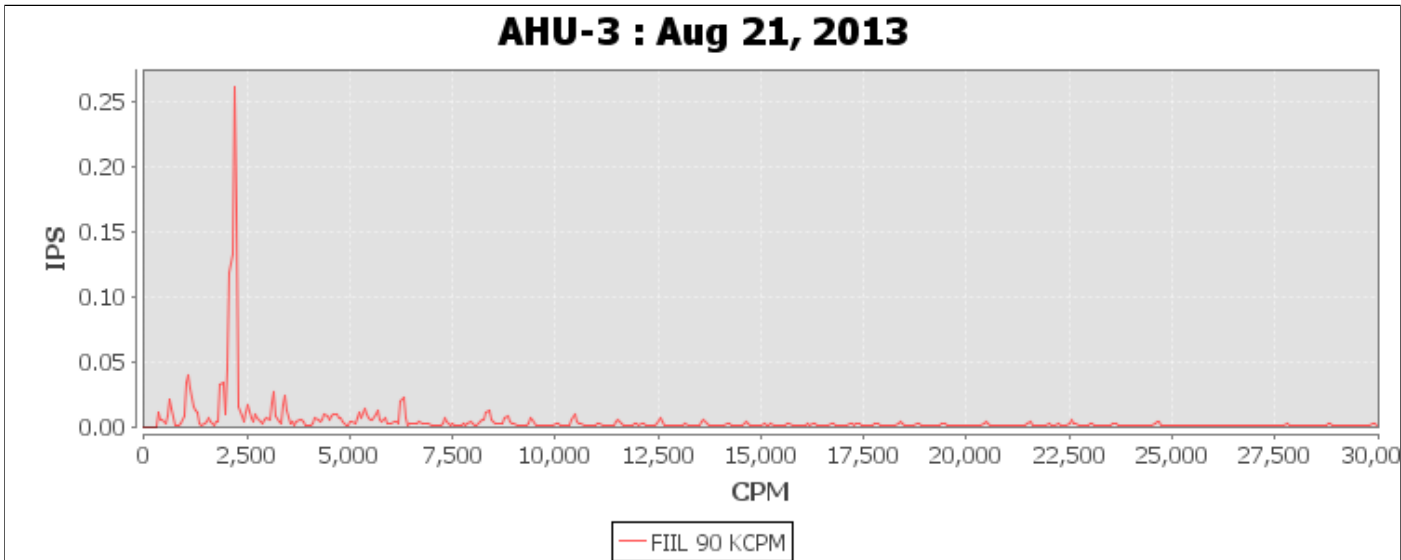

Recommendations: **Check the alignment of the motor and fan sheaves.**

Condition: **ALERT**

Analyzed By: Jacob Mulcahy

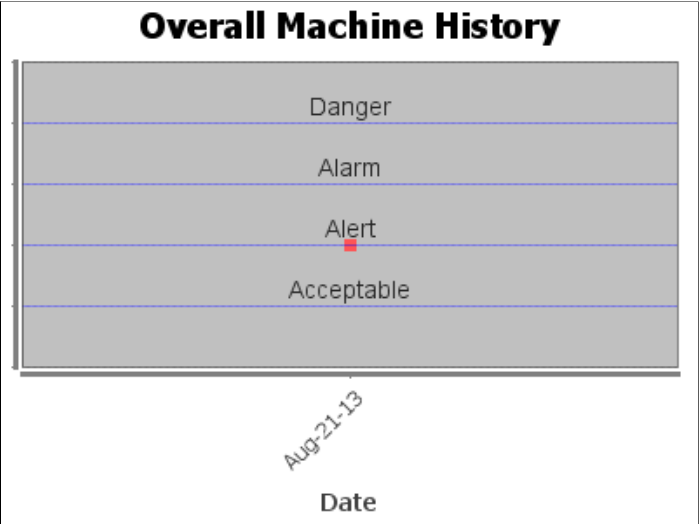
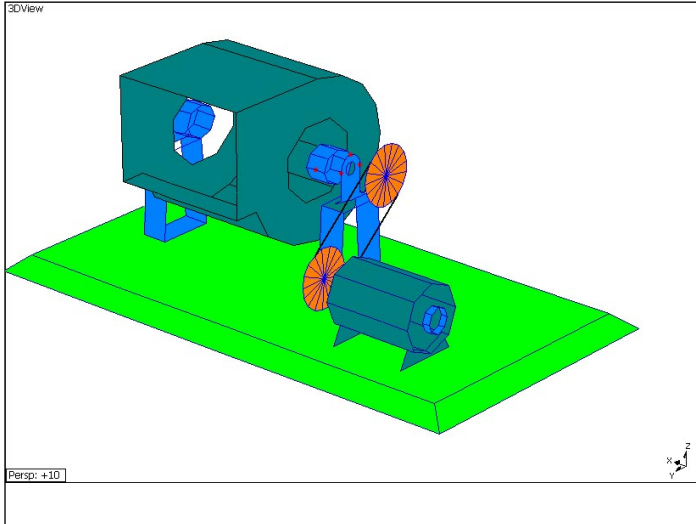

Recommendations

Check the alignment of the motor and fan sheaves.

Diagnosis

The vibration levels and harmonics of the fan turning speed indicate a possible sheave misalignment.

**AHU-5 : Aug 21, 2013**

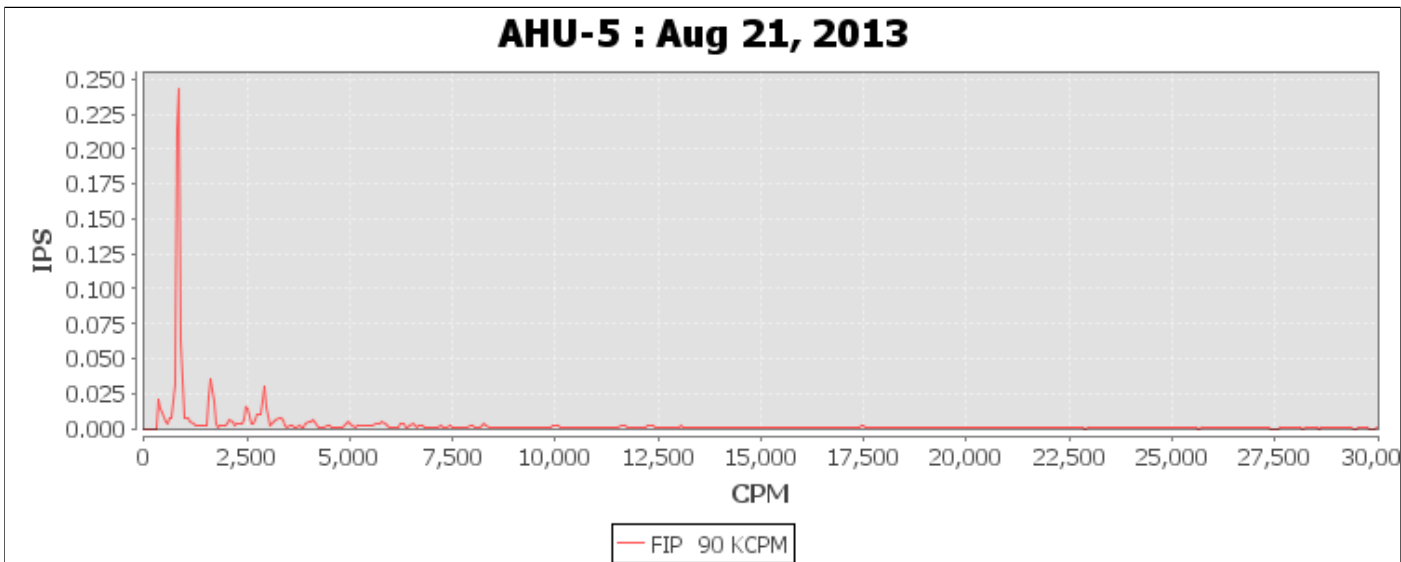

Recommendations: **Replace the fan bearings.**

Condition: **ALARM**

Analyzed By: Jacob Mulcahy

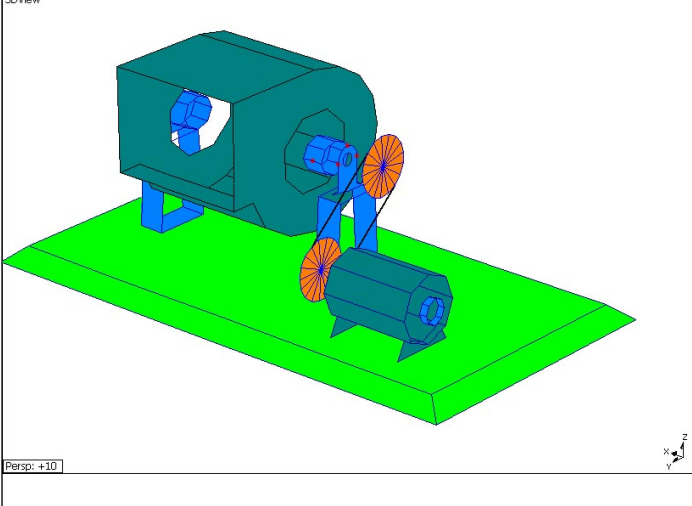

### Overall Machine History

Danger
Alarm <span style="color: red; font-weight: bold;">■</span>
Alert
Acceptable

Date

Recommendations

Replace the fan support bearings.

Diagnosis

The vibrations at a ball bearing defect frequencies indicate a problem with the fan support bearings.

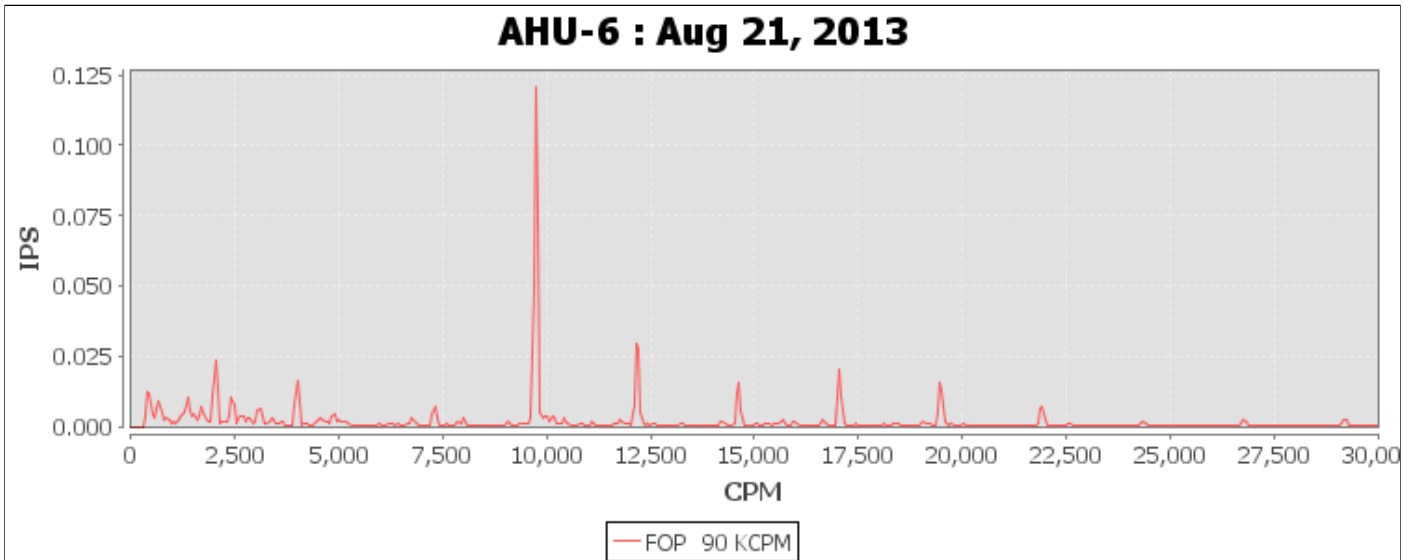

Recommendations:

**Check the alignment of the motor and fan sheaves. Check the motor sheave face and groove runout.**

Condition:

**ALARM**

Analyzed By: Jacob Mulcahy

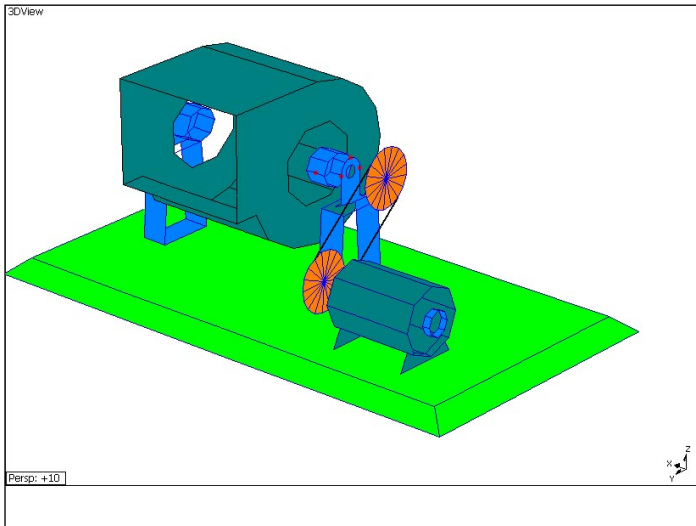

**Overall Machine History**

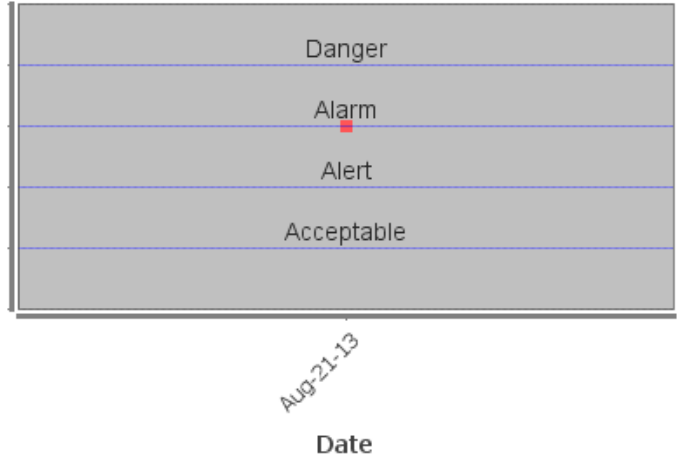

Recommendations

Check the alignment of the motor and fan sheaves. Check the motor sheave face and groove runout. The sheave runout should be 0.005 inches or less.

Diagnosis

The vibration levels and harmonics of the motor turning speed indicate a sheave misalignment. The vibration levels at the motor speed in the radial and axial direction indicate face or groove runout of the motor sheaves.

**AHU-8 : Aug 21, 2013**

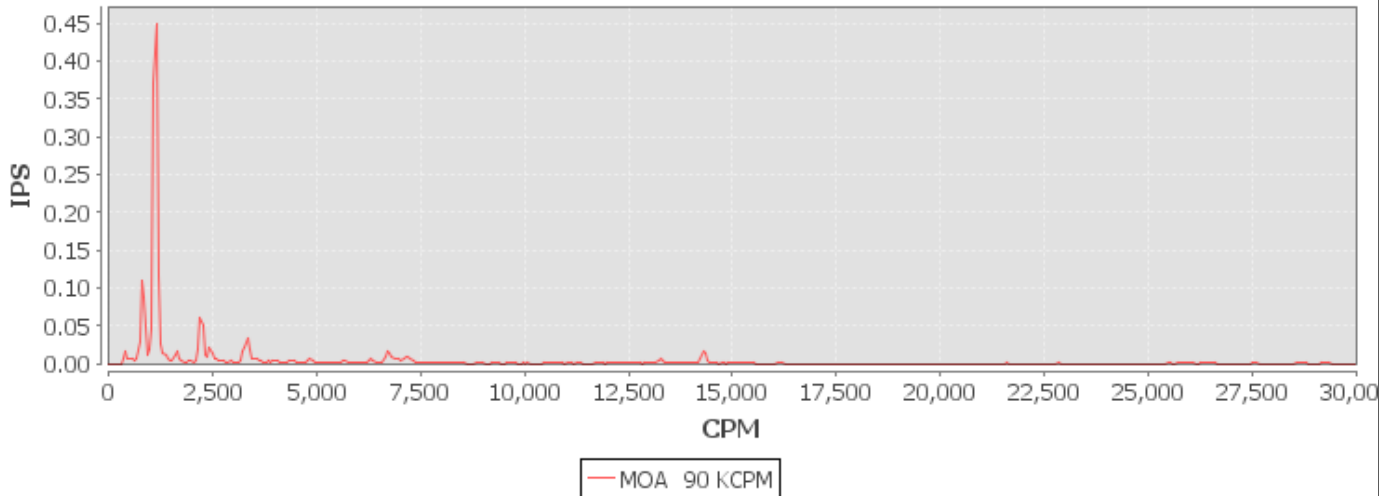

Recommendations: **Check the alignment of the motor and fan sheaves.**

Condition: **ALERT**

Analyzed By: Jacob Mulcahy

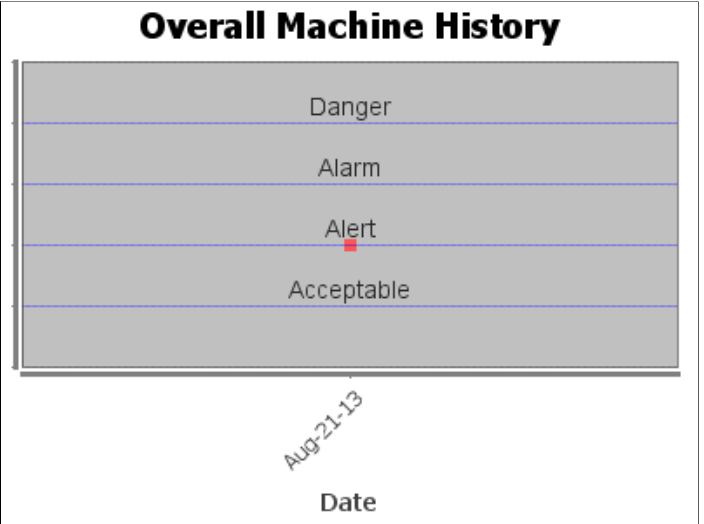
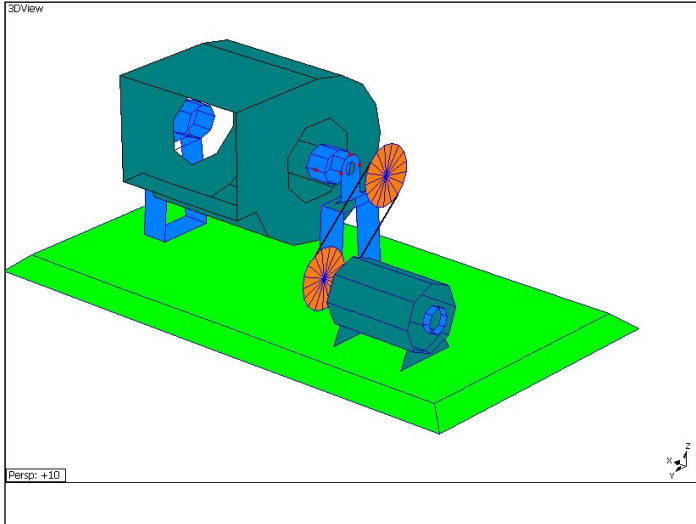

Recommendations

Check the alignment of the motor and fan sheaves.

Diagnosis

The vibration levels and harmonics of the fan turning speed indicate a possible sheave misalignment.

**AHU-10 : Aug 21, 2013**

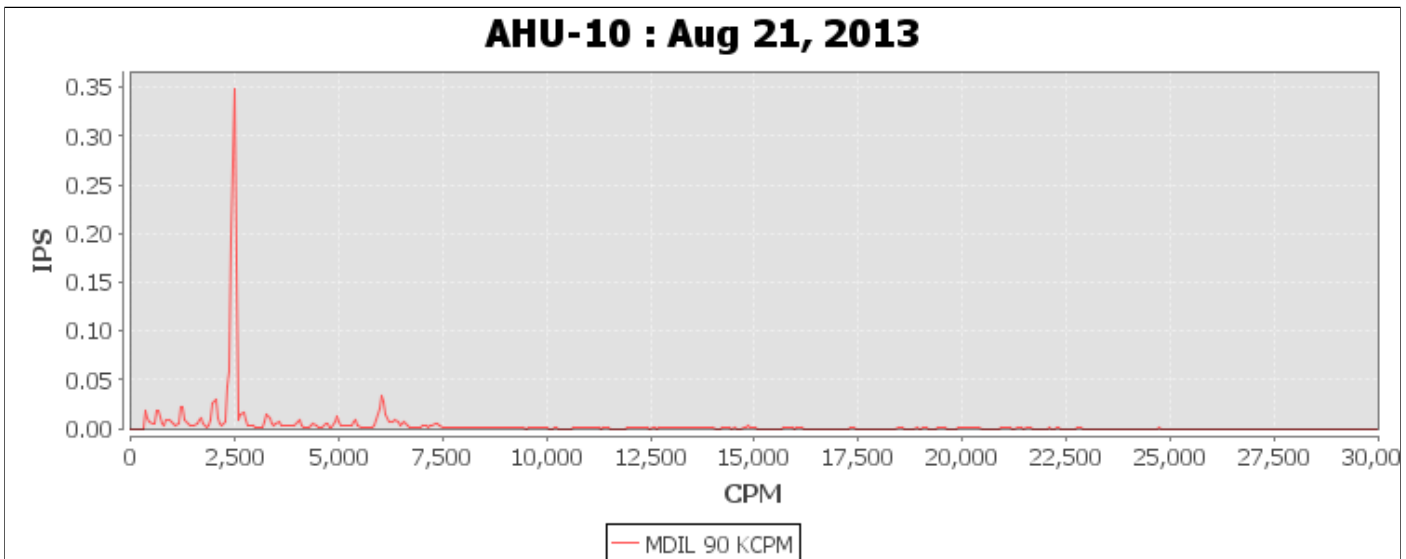

Recommendations: **Perform a precision shaft alignment.**

Condition: **ALERT**

Analyzed By: Jacob Mulcahy

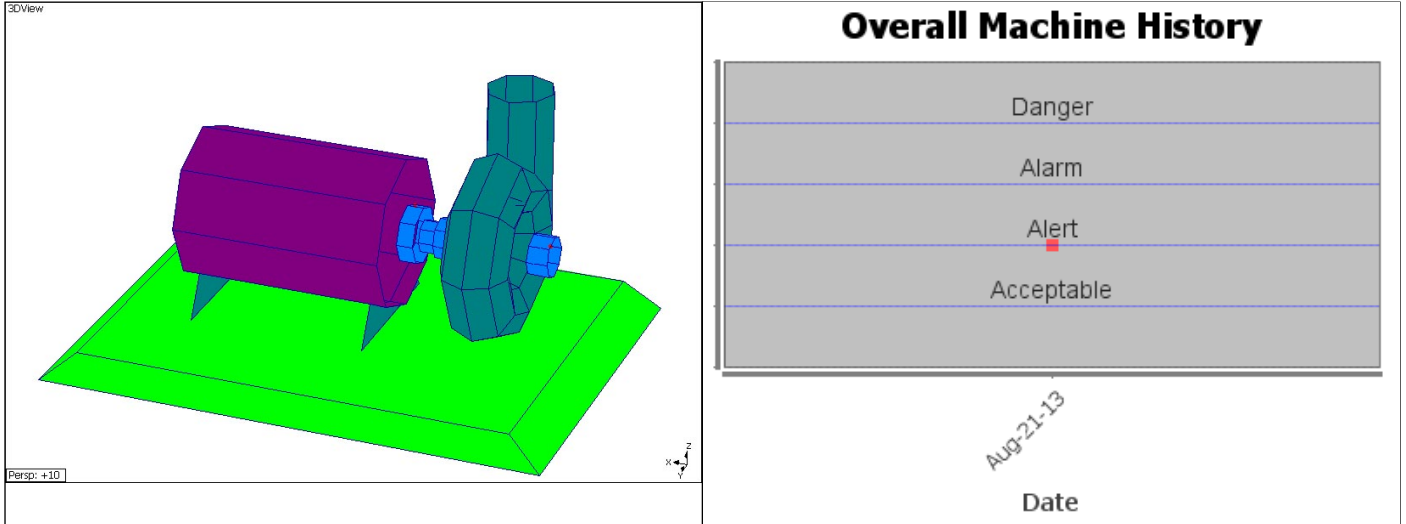

Recommendations

Perform a precision shaft alignment during the next scheduled maintenance shutdown.

Diagnosis

The vibration at 1x the running speed indicates a possible misalignment between the motor and pump.

**P-2 : Aug 21, 2013**



Recommendations: **Perform a precision shaft alignment.**

Condition: **ALERT**

Analyzed By: Jacob Mulcahy

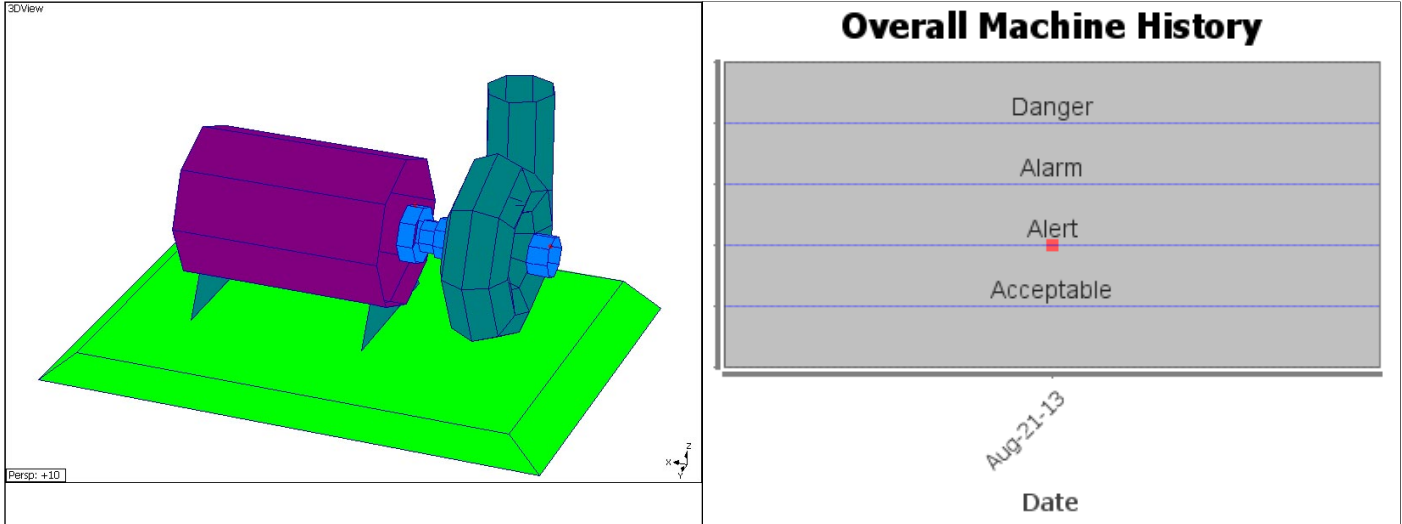

Recommendations

Perform a precision shaft alignment during the next scheduled maintenance shutdown.

Diagnosis

The vibration at 1x the running speed indicates a possible misalignment between the motor and pump.

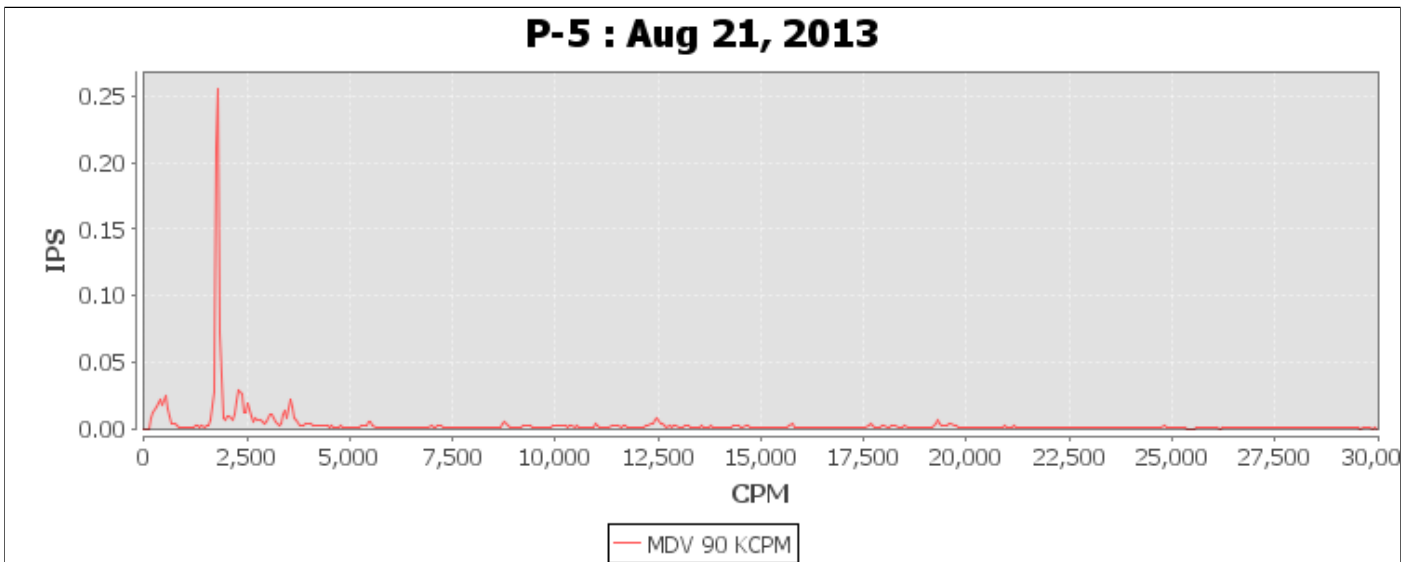

Recommendations: **Perform a precision shaft alignment.**

Condition: **ALERT**

Analyzed By: Jacob Mulcahy

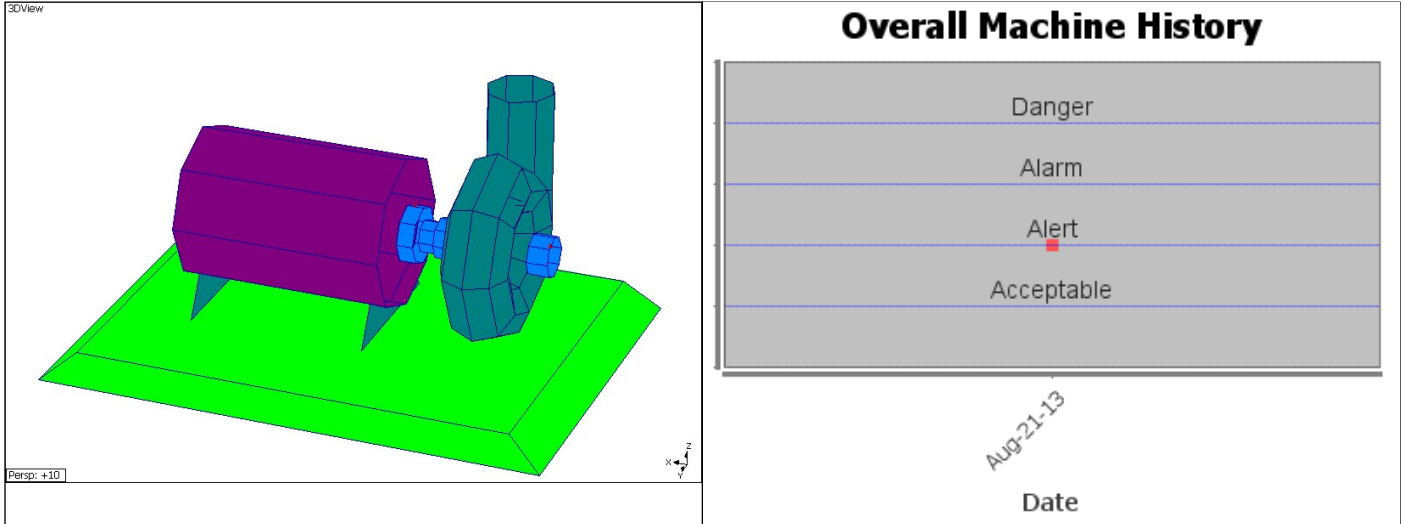

Recommendations

Perform a precision shaft alignment during the next scheduled maintenance shutdown.

Diagnosis

The vibration at 1x the running speed indicates a possible misalignment between the motor and pump.

**P-6 : Aug 21, 2013**

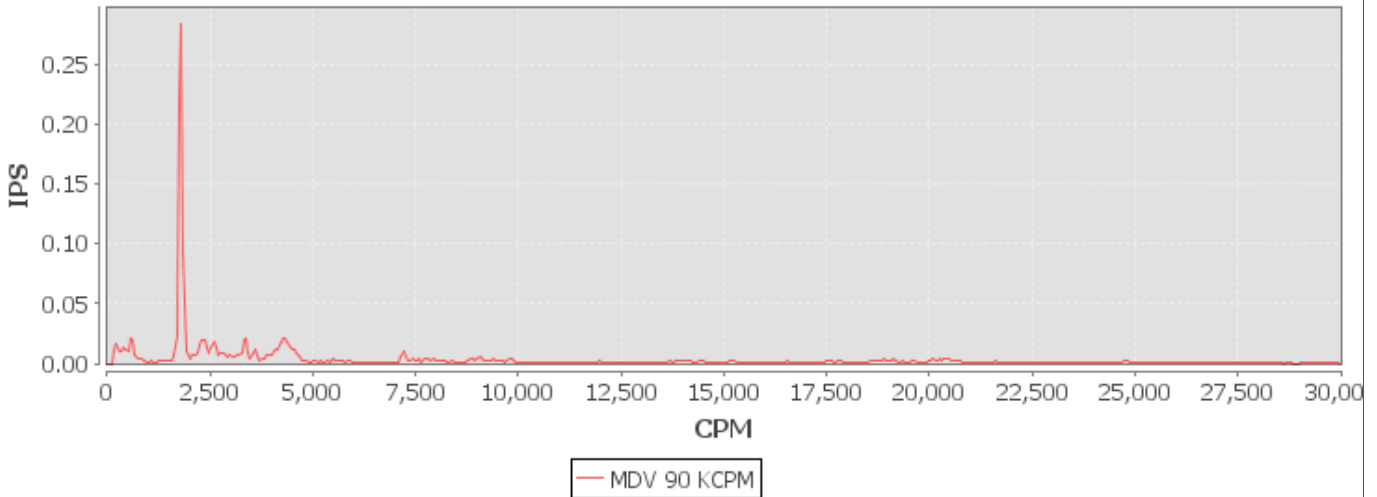

Recommendations: **Monitor the possible motor bearing defect.**

Condition: **ALERT**

Analyzed By: Jacob Mulcahy

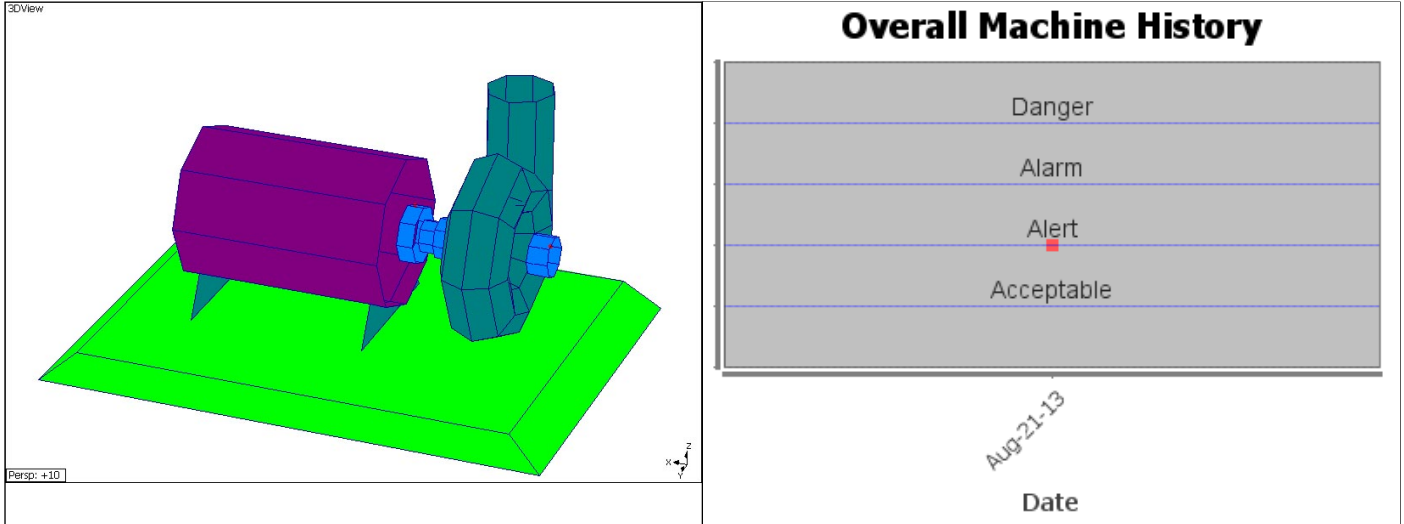

Recommendations

Continue to monitor the possible bearing defect frequencies on the motor bearings.

Diagnosis

The vibrations at the ball bearing defect frequencies indicate a possible problem with the motor support bearings.

**P-11 : Aug 21, 2013**

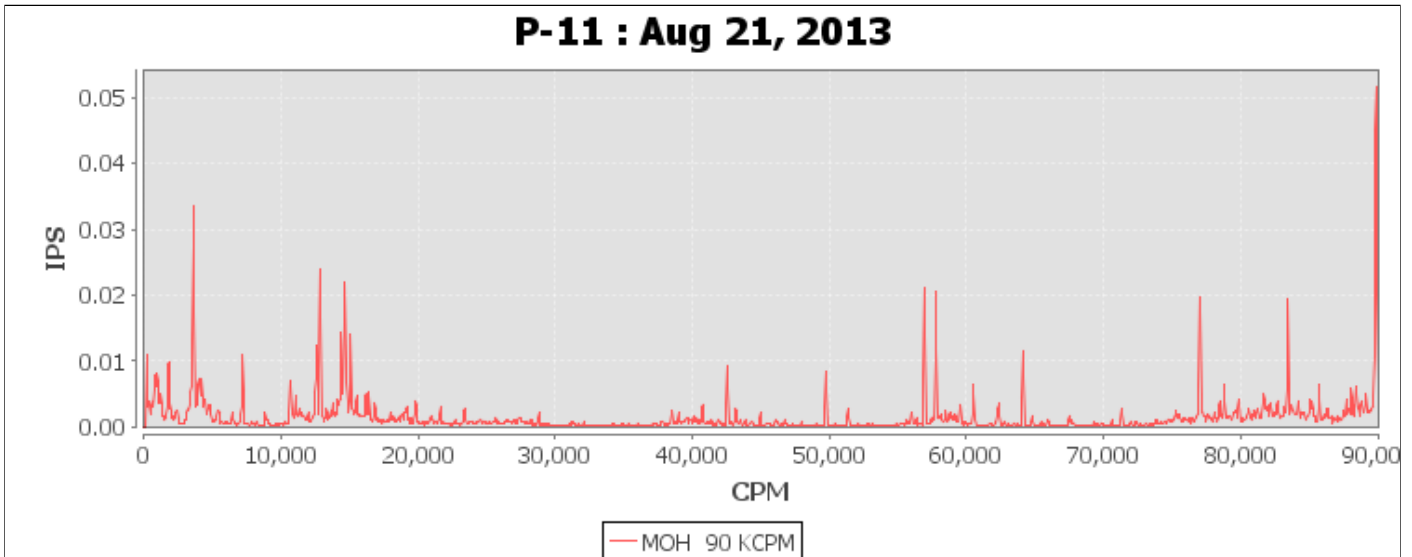

## 2 Bearing, Center Hung, Belt Driven, Fan Schematic

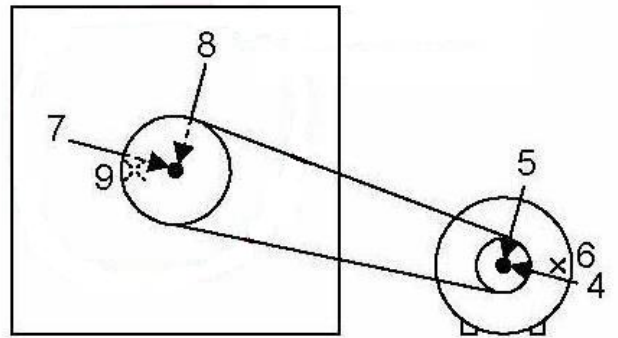
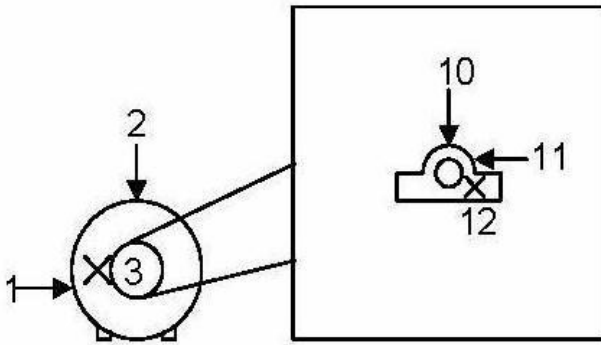

1. MOIL Motor off end in line
2. MOP Motor off end perpendicular
3. MOA Motor off end axial
4. MDIL Motor drive end in line
5. MDP Motor drive end perpendicular
6. MDA Motor drive end axial

7. FIIL Fan inboard in line
8. FIP Fan inboard perpendicular
9. FIA Fan inboard axial
10. FOIL Fan outboard in line
11. FOP Fan outboard perpendicular
12. FOA Fan outboard axial

## 2 Bearing Horizontal Pump Schematic

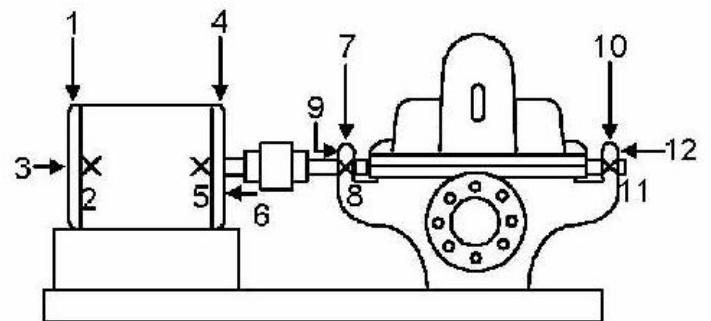
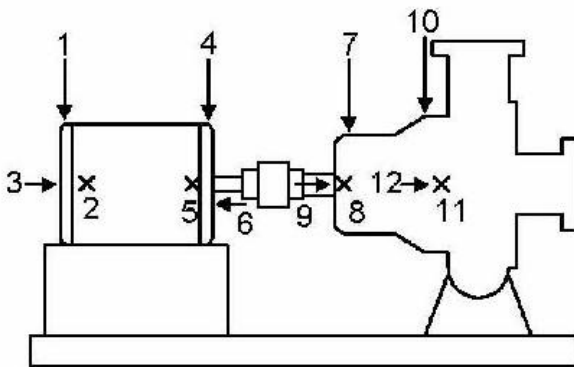

1. MOV Motor off end vertical
2. MOH Motor off end horizontal
3. MOA Motor off end axial
4. MDV Motor drive end vertical
5. MDH Motor drive end horizontal
6. MDA Motor drive end axial

7. PIV Pump inboard vertical
8. PIH Pump inboard horizontal
9. PIA Pump inboard axial
10. POV Pump outboard vertical
11. POH Pump outboard horizontal
12. POA Pump outboard axial

## ANALYSIS AND ASSESSMENT PROCESS

When analyzing fans and pumps, Johnson Controls categorizes the machines into three conditions called priorities. Categorizing equipment this way allows us to assist you with minimizing downtime and maintenance costs, preventing secondary damage, and increasing operating efficiency. See the section titled "Prioritized Repair Recommendations" for a detailed, prioritized list of your equipment.

To categorize the fans and pumps, Johnson Controls collected vibration data on the machines and analyzed their vibration levels. Using an SKF Microlog data collector, a strobe light, and an accelerometer vibration sensor, Johnson Controls collected vibration spectra on all machines. The following chart identifies our process:

Johnson Controls	To..	How do we do it?	Benefits to you
<p>Collect accurate data</p> <p>Makes visual observations and collects notes</p> <p>Identifies existing problems</p>	<p>Analyze the equipment and determine the condition of each machine.</p> <p>Help us make additional recommendations.</p> <p>Determine the types of repairs that must be completed.</p>	<p>We use the amplitude of a vibration at specific frequencies and compare it to a severity chart based on ISO standards and our own knowledge base. We also observe the machine as it is running, which offers a more precise indication of its condition.</p> <p>To assist with identifying problems, we relate the frequency at the amplitudes to the rotational speed of the machine components.</p>	<p>We can identify those specific machine components requiring repairs.</p> <p>We can help you find problems you may have missed and problems that don't show up in vibration analysis.</p> <p>You can arrange for the parts needed and ensure you have the right skills on hand for repairs.</p>
<p>Provides equipment-specific repair recommendations</p>	<p>Advise you on the proper corrective actions to take.</p>	<p>Our skilled and experienced vibration specialists prepare the recommendations based on their knowledge, the data collected, and physical observations.</p>	<p>You can make quick, effective, and informed decisions about your equipment and operations.</p>
<p>Prioritize equipment repairs</p>	<p>Inform you which repairs are most critical.</p>	<p>We determine which machines are in the worst condition and are most critical to your HVAC system and the areas it serves.</p>	<p>You can target repairs, resources, and your maintenance dollar on the most critical equipment, thus avoiding downtime and costly secondary damage.</p>
<p>Provides recommendations for improving maintenance practices</p>	<p>Inform you of better maintenance practices.</p>	<p>We base our recommendations on common problems we've identified in your facility.</p>	<p>You can train your staff to increase their skills and productivity.</p>
<p>Validates repairs</p>	<p>Verify that repairs were made.</p>	<p>We compare before and after data (spectra).</p>	<p>Your future repair costs and downtime are reduced, and the mean time between failures is increased.</p>

Johnson Controls can also perform repairs. We can collect follow-up vibration data for any repair work to check if any other problems exist, or to provide a baseline for future vibration analysis.

## **ANALYSIS AND ASSESSMENT PROCESS (continued)**

All Johnson Controls mechanics are trained in proper data collection techniques, analysis of common vibration problems, and corrective repairs using predictive techniques. The mechanics themselves are skilled tradesmen in the repair and operation of HVAC mechanical equipment. Johnson Controls mechanics have detailed documentation on the correct processes for performing data collection, analysis, and corrective action techniques.

Our mechanics are supported by five full-time engineers dedicated to supporting predictive technology and specifically vibration analysis. These engineers have been certified as Vibration Analysts by passing tests for different levels of certification from the Vibration Institute or Technical Associates of Charlotte. The Vibration Institute is a professional society dedicated to the science of using machinery vibration to detect developing problems before they cause any unexpected failures. Technical Associates of Charlotte (James E. Berry, vice president) is a consultant and training group for using vibration to detect developing problems.

# GLOSSARY OF VIBRATION, ALIGNMENT, AND BALANCING TERMS

## 1X

The running speed of a machine, or its fundamental frequency. This frequency is most commonly used to assess the amount of imbalance.

## 2X,3X

The frequency at 2 or 3 times the running speed of a machine. This frequency is most commonly used to assess misalignment.

## acceleration

The change of velocity; measures how a machine's vibration changes speed. Acceleration is typically measured in G's (1G=32.17 ft/s/s=9.81 m/s/s). Measurements are usually made with an accelerometer. Acceleration is used to assess high frequencies (over 2,000 Hz) such as gear mesh frequencies.

## accelerometer

A transducer that collects vibration data; used with a vibration data collector such as the SKF Microlog.

## alignment

A procedure used to correct misalignment. The reverse dial indicator method used by Johnson Controls is considered to be one of the most accurate alignment methods available.

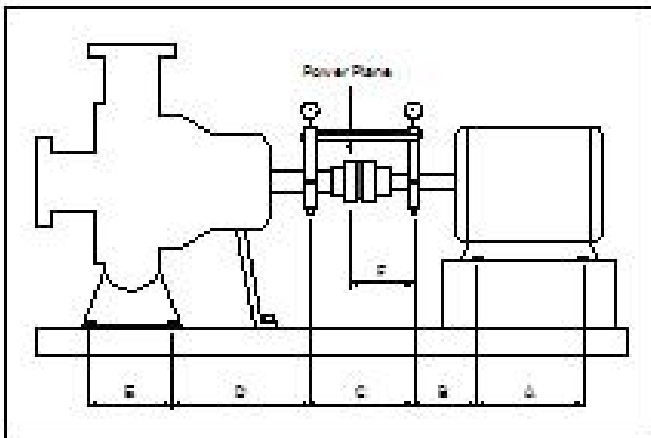

Figure 1: Measurements and setup for the reverse dial indicator method of alignment.

## amplitude

The amount (severity) of vibration that a machine exhibits. Amplitude is used to determine the severity of a mechanical equipment problem. Because all machines exhibit vibration, all machines also exhibit amplitude: the greater the amplitude (the severity of the

vibration), the greater the problem. Amplitude is most often measured in IPS (inches per second), but can also be measured in G's or mils. Sometimes referred to as vibration level.

## averaging

In a vibration analyzer, digitally averaging several measurements improves accuracy.

## axial

In the same direction as the shaft centerline.

## axial vibration

Vibration which is measured parallel to the shaft's centerline.

## axis

The reference plane used in plotting routines. The X-axis is the frequency plane. The Y-axis is the amplitude plane.

## balancing

A procedure for adjusting the radial mass distribution on a rotor so that the mass centerline approaches the rotor geometric centerline.

## baseline, baseline spectrum

Spectra collected and stored for future comparison. The baseline is taken when a machine is in good operating condition and is used as a reference for future monitoring and analysis.

## bearing defect frequencies

The vibration frequencies that are monitored to determine if there are roller or ball bearing defects.

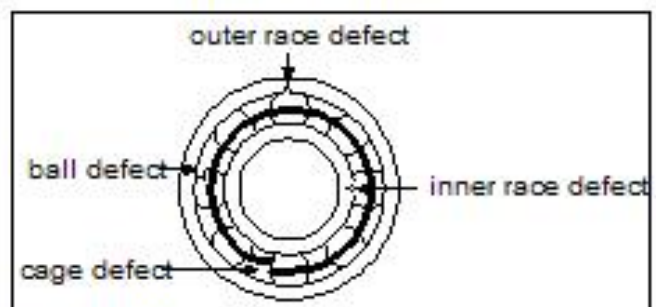

Figure 2: Typical bearing defects.

## bent shaft

A shaft condition that is usually caused by excessive

force or imbalance; causes excessive vibration.

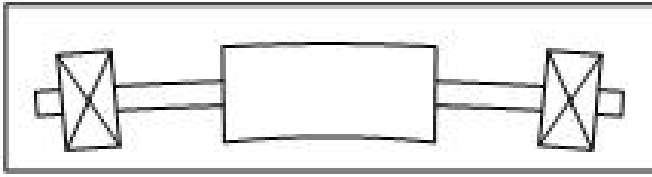

Figure 3: Bent shaft.

### blade passing frequency

The vibration frequency used to monitor the condition on any bladed machine (turbine, axial compressor, fan, etc.). Blade pass frequency is represented by multiplying the number of blades by the shaft-rotating frequency. Example: A 40-blade cage fan rotating at 1,200 RPM has a blade pass frequency of 48,000 RPM.

### BPFO, BPF1

The bearing defect frequencies for the outer and inner races of a roller or ball bearing. See also bearing defect frequencies.

### BSF

The bearing defect frequency created by the spinning of ball bearings or rolling elements.

### calibration

A test to ensure that the transducer on the vibration data collector is collecting accurate measurements.

### cost up/coast down

The monitoring of machinery conditions (vibration amplitude) during a start-up or shutdown process. See also run up/run down.

### condition monitoring

A method of determining the condition of a machine by interpreting measurements taken either periodically or continuously while the machine is running. Also referred to as predictive maintenance.

### CPM

Cycles per minute. A measurement of frequency; frequency is also measured in CPS and Hz.

### CPS

Cycles per second; also referred to as Hertz (Hz). A measurement of frequency; frequency is also measured in CPM.

### critical speeds

In general, any rotating speed which is associated with high vibration amplitude. Often, the critical speeds are the rotor speeds which correspond to natural frequencies of the system.

### data collector

An instrument, such as the SKF Microlog, use to collect vibration measurements.

### diagnostic frequency

The frequency at which a major machine component vibrates, including such components as the motor shaft, compressor shaft, ball bearings, gear mesh, and blade pass.

### displacement

Measures the actual distance a machine travels as it vibrates; expressed in mils. The vibration amplitude of displacement frequencies is monitored and used to assess the condition of a machine's components. Displacement is used to measure amplitude for machines operating below 600 RPM.

### download

Transferring information to the data collection device from the host computer.

### eccentricity, mechanical

The variation of the outer diameter of a shaft surface when referenced to the true geometric centerline of the shaft. Out-of-roundness.

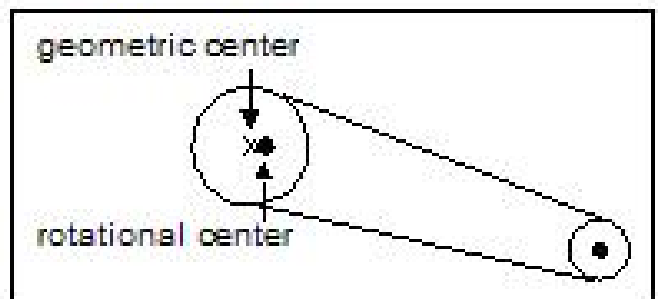

Figure 4: Eccentric sheave.

### FIA

Vibration measurement point; stands for Fan Inboard Axial.

### FIIIL

Vibration measurement point; stands for Fan Inboard In Line.

#### **FIP**

Vibration measurement point; stands for Fan Inboard Perpendicular.

#### **FOA**

Vibration measurement point; stands for Fan Outboard Axial.

#### **FOIL**

Vibration measurement point; stands for Fan Outboard In Line

#### **FOP**

Vibration measurement point; stands for Fan Outboard Perpendicular.

#### **Fast Fourier Transform (FFT)**

Also known as vibration spectrum. See spectrum.

#### **fluid-film bearing**

A bearing which supports the shaft on a thin film of oil. The fluid-film layer may be generated by journal rotation (hydrodynamic bearing) or by externally applied pressure (hydrostatic bearing). Also referred to as journal bearing.

#### **frequency**

How often a repeating event happens in a period of time; for example, one shaft revolution is an event.

Frequency is used to identify the source of a vibration because different mechanical problems cause different frequencies. Frequency is measured in revolutions per minute (RPM), cycles per minute (CPM), cycles per second (CPS), and Hertz (Hz).

#### **frequency range**

The frequency range (vibration) over which a measurement is collected. Usually refers to upper frequency limit of analysis, considering zero as the lower analysis limit. Example: A 0-200 Hz measurement is a measurement collected from a range of 0 to 200 Hz.

#### **G's**

1 G = 32.2 ft/s/s. Used to express acceleration of vibration.

#### **gear mesh frequency**

The frequency generated by two or more gears meshing teeth together. Used to monitor the condition of the gears. Gear mesh frequency is equal to the number of times the gear teeth impact each other in one revolution. Example: The gear mesh frequency for a large 36-tooth gear running at 10 RPM is 360.

#### **harmonic**

A frequency that is an integer multiple of a fundamental frequency. For example, 5400 RPM is the third harmonic of 1800 RPM. Harmonics often indicate a worsening machinery condition. Harmonics are produced either by an event that occurs multiple times per revolution, or by a distortion of the running speed component's pure sine wave.

#### **heavy spot**

The representation of imbalance on a shaft. The heavy spot does not change with rotational speed. Determining the location of a heavy spot allows for the placement of a counter-weight to correct the imbalance.

#### **Hz**

Hertz. Also referred to as cycles per second (CPS): RPM/60. A measurement of frequency; frequency is also measured in CPM.

#### **imbalance (unbalance)**

Occurs when a shaft's geometric centerline and mass centerline do not coincide; that is, there is a heavy spot somewhere along the shaft. Imbalance is the second biggest contributor to excessive machinery vibration.

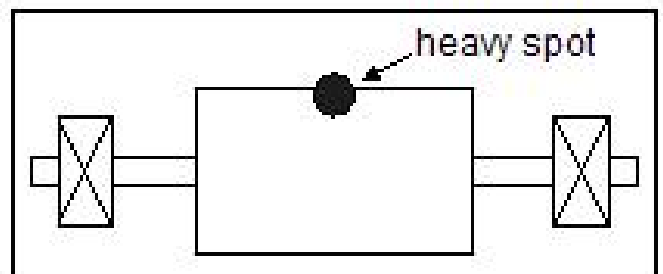

Figure 5: Imbalanced shaft.

#### **IPS**

Inches per second. A measurement of vibration.

#### **journal bearing**

A plain cylindrical bearing.

**line frequency**

The frequency of the electrical supply current; 60 Hz in North America, 50 Hz in other parts of the world.

**looseness**

Occurs when machinery parts are not properly fitted together; causes excessive vibration.

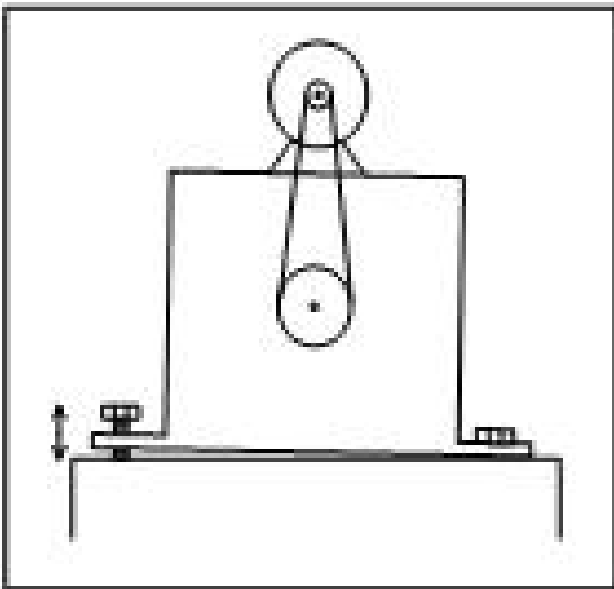

Figure 6: Machine with a loose mounting bolt.

**MDA**

Vibration measurement point; stands for Motor Drive End Axial.

**MDH**

Vibration measurement point; stands for Motor Drive End Horizontal.

**MDIL**

Vibration measurement point; stands for Motor Drive End In Line.

**MDP**

Vibration measurement point; stands for Motor Drive End Perpendicular.

**MDV**

Vibration measurement point; stands for Motor Drive End Vertical.

**MOA**

Vibration measurement point; stands for Motor Outboard Axial.

**MOH**

Vibration measurement point; stands for Motor Off End Horizontal.

**MOIL**

Vibration measurement point; stands for Motor Outboard In Line.

**MOP**

Vibration measurement point; stands for Motor Outboard Perpendicular.

**MOV**

Vibration measurement point; stands for Motor Off End Vertical.

**magnetic base**

A magnet used to mount an accelerometer to a machine surface when collecting vibration data.

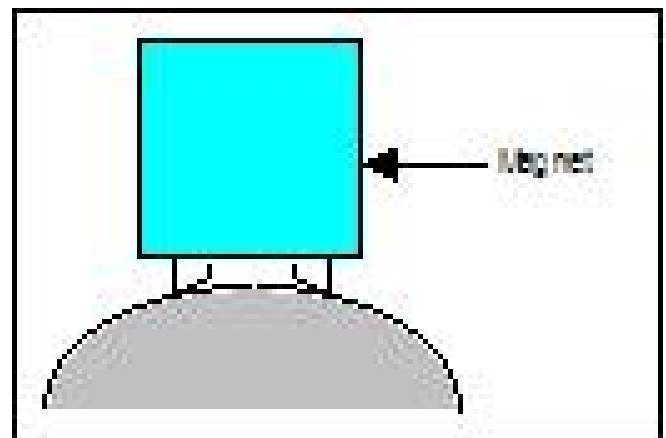

Figure 7: The magnetic base can be mounted to metal surfaces for vibration data collection while a machine is running.

**measurement point**

The location specified for locating the accelerometer on the machine surface for collecting vibration data.

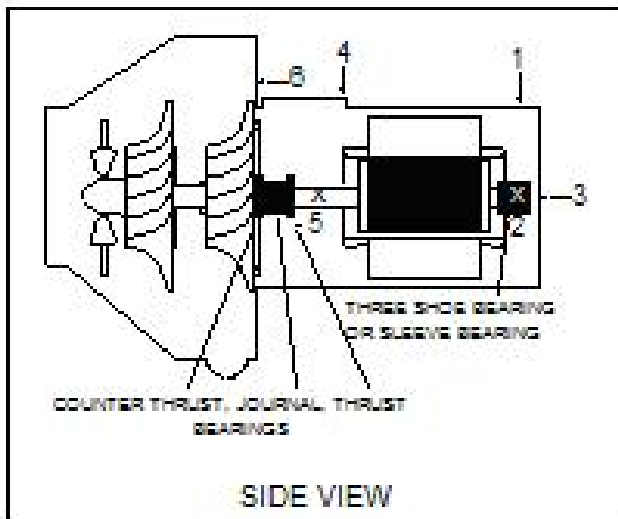

Figure 8: This Carrier 19C chiller requires six measurements points for data collection.

**mil**

One thousandth (0.001) of an inch. (1 mil = 25.4 microns.) A measurement of vibration’s displacement.

**misalignment**

Occurs when shaft centerlines are not collinear (occupying the same space) during machine operation. Misalignment is the most common contributor to excessive machinery vibration.

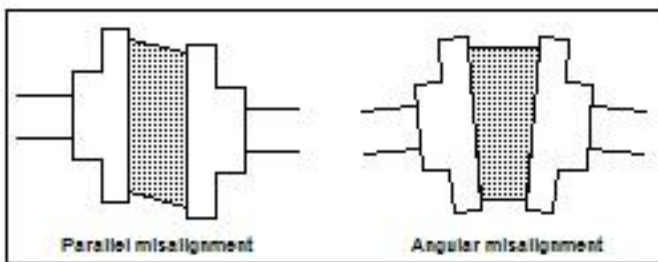

Figure 9: Two types of coupling misalignment.

**mounting base, mounting tab**

A threaded steel tab that is glued to the surface of a geared chiller; the accelerometer is then mounted to each mounting tab at specified measurement points to collect vibration data.

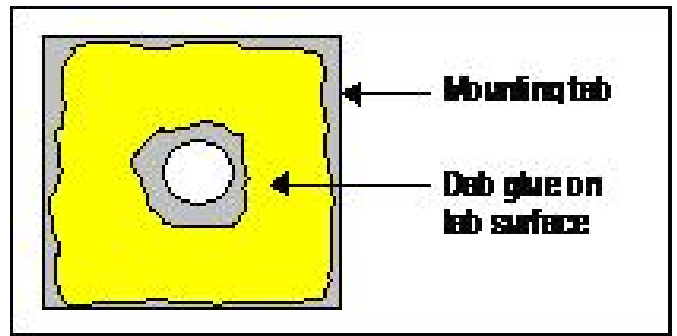

Figure 10: Once glue is applied to the tab, the tab is pressed to the machine surface at defined measurement points and allowed to dry.

**natural frequency**

The frequency of free vibration of a system. Resonance exists when a machine vibrates at its natural frequency. See also resonance.

**overall**

The sum of all the energy within a specified frequency band. Overall can be calculated by using the root-mean-square (rms) equation.

**PIA**

Vibration measurement point; stands for Pump Inboard Axial.

**PIH**

Vibration measurement point; stands for Pump Inboard Horizontal.

**PIV**

Vibration measurement point; stands for Pump Inboard Vertical.

**POA**

Vibration measurement point; stands for Pump Outboard Axial.

**POH**

Vibration measurement point; stands for Pump Outboard Horizontal.

**POV**

Vibration measurement point; stands for Pump Outboard Vertical.

**phase**

A measurement of the timing relationship between two signals or between a specific vibration event and a

strobe light pulse.

### **phase reference**

The reference signal used in rotating machinery measurements that is generated by a sensor observing a once-per-revolution event. Phase reference is used to measure the phase relationship at other measurement points.

### **point**

The vibration data at a measurement location.

### **proactive maintenance**

A maintenance approach that focuses on identifying and correcting the root causes of machinery problems. Proactive maintenance reduces maintenance and energy costs, downtime, secondary damage, and unnecessary parts replacement.

### **radial**

Vibration measured perpendicular to a shaft's centerline.

### **radial vibration**

Shaft dynamic motion or casing vibration that is in a direction perpendicular to the shaft centerline.

### **repeatability**

The ability of an accelerometer or transducer to reproduce readings when the same input is applied repeatedly. Watching for repeatability ensures that measurements are accurate.

### **redundancy**

A piece of equipment that has a duplicate to be used as a backup. If a non-redundance piece of equipment fails, services cannot continue until the equipment is repaired or replaced.

### **resonance**

Occurs when a machine's vibration frequency is the same as the natural frequency of one of its components. See also natural frequency.

### **RPM**

Revolutions per minute. A measurement of frequency.

### **rolling element bearing**

Bearing whose low friction qualities derive from rolling

elements (balls or rollers), with little lubrication.

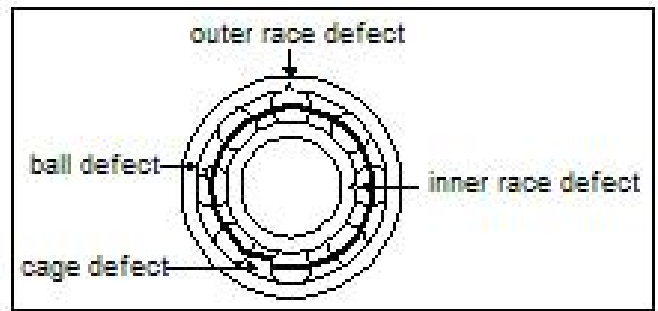

Figure 11: Typical defects on a rolling element bearing.

### **rotor bar passing frequency**

The periodic pulsation in an induction motor equal to the number of rotor bars times the RPM of the rotor. The frequency is used to monitor the condition of the rotor.

### **route**

A list of data collection points and machines for a customer location that the Predictive Diagnostics Team downloads to the SKF Microlog. Data is collected for a route in the order the points are given.

### **run up/run down**

The monitoring of machinery conditions during a start-up or shutdown process. Also referred to as coast up/coast down.

### **sideband**

Evenly spaced peaks centered around a major peak in a spectrum. When sidebands have high amplitude and there are many sidebands occurring in a spectrum, the machine condition is worsening.

### **signature**

See spectrum.

### **slip frequency**

The difference in frequency or speed between the synchronous speed of the stator and the actual speed of the rotor. Slip frequency is monitored to assess the condition of the rotor.

### **spectrum**

A graphical representation of frequencies and their amplitudes. Created through vibration analysis; it is distinctive and special to a machine or component, system, or subsystem at a specific point in time, and under specific machine operating conditions. Spectra

can be used to diagnose specific machinery problems and to build an historical comparison of mechanical condition over the operating life of a machine. Spectra is plural for spectrum. Also known as a vibration spectrum, signature, or Fast Fourier Transform (FFT).

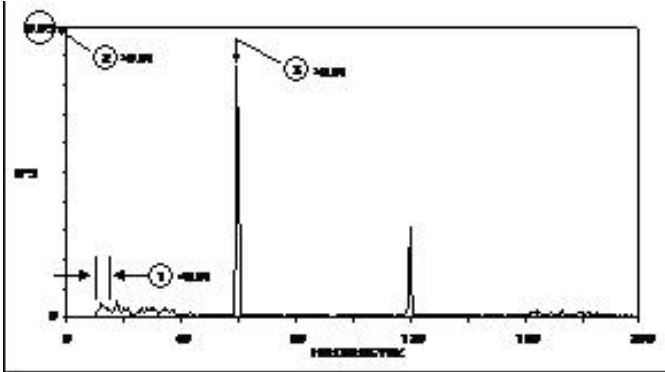

Figure 12: Spectrum showing vibration data collected on a chiller.

**stator**

The non-rotating component of an induction motor, comprised of a stack of laminated plates that carry two conductors per slot to provide a rotating magnetic field.

**transducer**

A device that translates a physical quantity into an electrical output.

**trend**

The measurement of a variable (such as vibration) over time.



Figure 13: Trend Plot.

**trigger**

Can be used to initiate a measurement so a phase relationship can be established.

**unbalance**

See imbalance.

**upload**

Transferring data from the data collection device to the host computer.

**velocity**

The speed of vibration. Velocity is measured in inches per second (IPS) and is one of the most common units used to express amplitude.

**vibration**

Back and forth motion. Common machinery problems generate forces that change direction as machines rotate. This results in vibration that repeats.

**vibration analysis**

A method of diagnosing machinery problems, determining the severity of those problems, and forecasting the most appropriate time to correct them. Vibration analysis is a predictive maintenance technology.

**vibration level**

The magnitude of vibration. Sometimes referred to as amplitude, most often measured in IPS.

**vibration spectrum**

See spectrum.

**waterfall**

A three-dimensional multiple spectra display.