

- C
- Product Index
- Compact Flow Controls
- Miniature Flow Controls
- Swivel Flow Controls
- Plug-in Flow Controls
- In-Line Flow Controls
- Metal Flow Controls
- Check Valves
- Blocking Valves
- Threshold Sensors

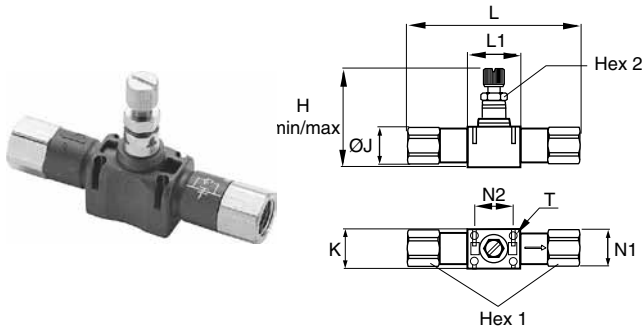

FC836 Threaded In-Line Flow Control - BSPP

Part No.	BSPP	Hex 1 (mm)	Hex 2 (mm)	H Closed	H Open	K	L	N1	N2	T
FC836-2G	1/8"	13	8	39.5	44.5	17.0	68.5	11.0	17.0	3.2
FC836-4G	1/4"	16	11	44.0	50.0	18.5	83.0	12.5	20.0	3.2
FC836-6G	3/8"	19	14	52.0	61.0	24.0	97.0	16.0	26.0	4.2
FC836-8G	1/2"	24	14	57.5	67.5	28.0	121.0	20.0	27.5	4.2

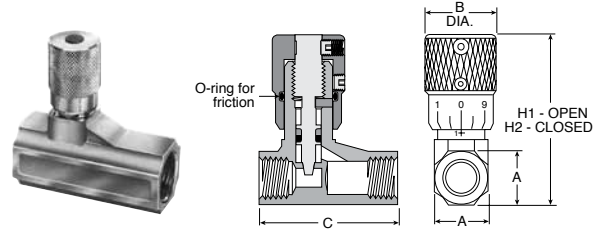

338 Bi-directional Flow Control Valves

Part No.	Port Size	A	B	C	H1	H2
00338 1100	1/8"	9/16"	0.75	1.47	2.03	1.81
00338 1101	1/4"	11/16"	0.75	1.47	2.28	2.03
00338 1102	3/8"	7/8"	0.88	2.31	2.84	2.53
00338 1103	1/2"	1-3/16"	1.06	3.25	3.62	3.22
00338 1104	3/4"	1-3/8"	1.06	3.25	3.72	3.31

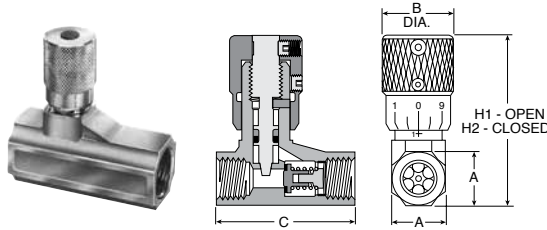

337 Micrometer Flow Control Valves

Part No.	Port Size	A	B	C	H1	H2
00337 1000	1/8"	9/16"	0.75	1.47	2.03	1.81
00337 1001	1/4"	11/16"	0.75	1.47	2.28	2.03
00337 1002	3/8"	7/8"	0.88	2.31	2.84	2.53
00337 1003	1/2"	1-3/16"	1.06	3.25	3.62	3.22
00337 1004	3/4"	1-3/8"	1.06	3.25	3.72	3.31

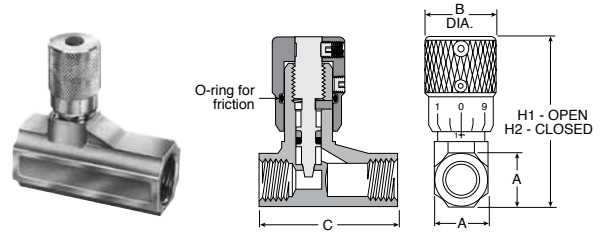

338 Bi-directional Flow Control Valves - BSPP

Part No.	Port Size	A	B	C	H1	H2
00338G1100	1/8"	9/16"	0.75	1.47	2.03	1.81
00338G1101	1/4"	11/16"	0.75	1.47	2.28	2.03

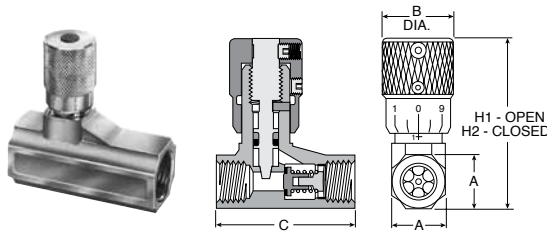

337 Micrometer Flow Control Valves - BSPP

Part No.	Port Size	A	B	C	H1	H2
00337G1000	1/8"	9/16"	0.75	1.47	2.03	1.81
00337G1001	1/4"	11/16"	0.75	1.47	2.28	2.03