

aerospace  
climate control  
electromechanical  
filtration  
fluid & gas handling  
hydraulics  
**pneumatics**  
process control  
sealing & shielding

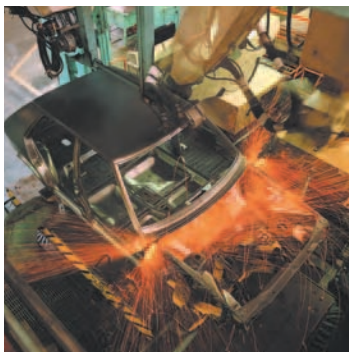

# Air Preparation Products

Filters, Regulators, Lubricators,  
& Airline Accessories

Catalog 0700P-E



ENGINEERING YOUR SUCCESS.

**Distributor Network, Warning, Offer of Sale****DISTRIBUTION NETWORK**

At Parker, we have the largest global distribution network in motion and control, with over 7,500 distributors serving more than 422,000 customers.

To find the distributor nearest you, please visit our DISTRIBUTOR LOCATOR at <http://www.parker.com/pneu/distributor>



**ENGINEERING YOUR SUCCESS.**

 **WARNING**

FAILURE OR IMPROPER SELECTION OR IMPROPER USE OF THE PRODUCTS AND/OR SYSTEMS DESCRIBED HEREIN OR RELATED ITEMS CAN CAUSE DEATH, PERSONAL INJURY AND PROPERTY DAMAGE.









This document and other information from Parker Hannifin Corporation, its subsidiaries and authorized distributors provide product and/or system options for further investigation by users having technical expertise. It is important that you analyze all aspects of your application including consequences of any failure, and review the information concerning the product or system in the current product catalog. Due to the variety of operating conditions and applications for these products or systems, the user, through its own analysis and testing, is solely responsible for making the final selection of the products and systems and assuring that all performance, safety and warning requirements of the application are met.

The products described herein, including without limitation, product features, specifications, designs, availability and pricing, are subject to change by Parker Hannifin Corporation and its subsidiaries at any time without notice.

**Offer of Sale**

The items described in this document are hereby offered for sale by Parker Hannifin Corporation, its subsidiaries or its authorized distributors. This offer and its acceptance are governed by the provisions stated on the separate page of this document entitled "Offer of Sale".

**Index**

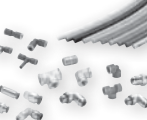



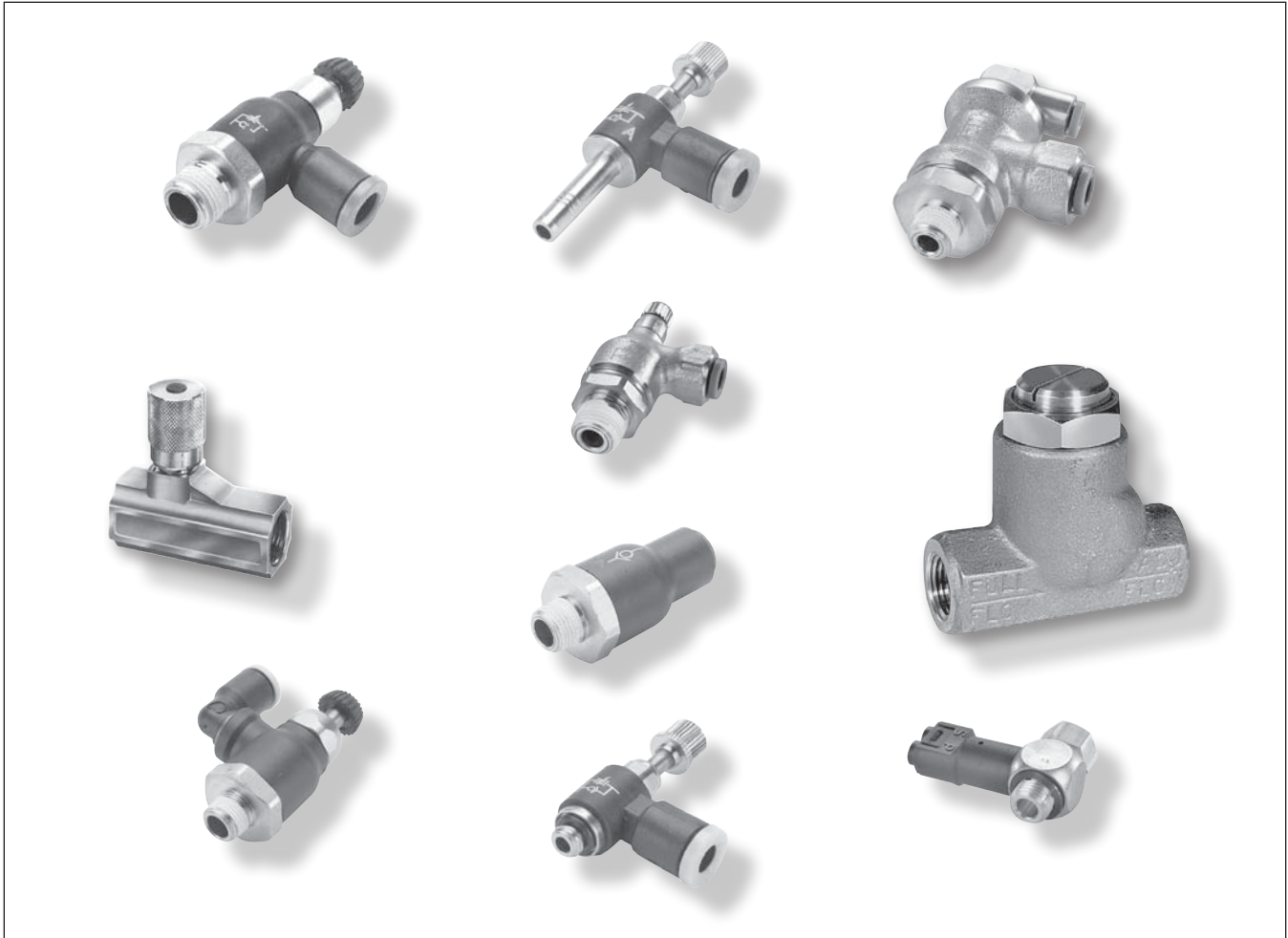

































<p><b>Introduction</b></p>	<p><b>A</b> Introduction</p>
<p><b>Global Air Preparation System</b>      <a href="http://www.parker.com/globalfrl">www.parker.com/globalfrl</a></p>	<p><b>B</b> Global Air Preparation Systems</p> 
<p><b>Filters, Regulators, Lubricators</b>      <a href="http://www.parker.com/pneu/frl">www.parker.com/pneu/frl</a></p>	<p><b>C</b> Filters, Regulators, Lubricators</p> 
<p><b>Stainless Steel FRLs</b>      <a href="http://www.parker.com/pneu/ssfrls">www.parker.com/pneu/ssfrls</a></p>	<p><b>D</b> Stainless Steel FRLs</p> 
<p><b>Precision Regulators</b>      <a href="http://www.parker.com/pneu/precereg">www.parker.com/pneu/precereg</a></p>	<p><b>E</b> Precision Regulators</p> 
<p><b>Proportional Regulators</b> (P31P, P32P &amp; PAR™-15)</p>	<p><b>F</b> Proportional Regulators</p> 
<p><b>LV / EZ Lockout Valves</b> (Lockout Valves)      <a href="http://www.parker.com/pneu/lockout">www.parker.com/pneu/lockout</a></p>	<p><b>G</b> “LV” / “EZ” Lockout Valves</p> 
<p><b>Integrated Fittings</b></p>	<p><b>H</b> Integrated Fittings</p> 
<p><b>Accessories</b>      <a href="http://www.parker.com/pneu/accessories">www.parker.com/pneu/accessories</a></p>	<p><b>J</b> Accessories</p> 
<p><b>Ball Valves / Plug Valves</b>      <a href="http://www.parker.com/pneu/ball">www.parker.com/pneu/ball</a></p>	<p><b>K</b> Ball Valves / Plug Valves</p> 
<p><b>Quick Couplings</b></p>	<p><b>L</b> Quick Couplings</p> 
<p><b>Hose &amp; Fittings</b></p>	<p><b>M</b> Hose and Fittings</p> 
<p><b>Tubing &amp; Fittings</b></p>	<p><b>N</b> Tubing and Fittings</p> 
<p><b>Safety Guide, Offer of Sale</b></p>	<p><b>P</b> Model to Page Number Index</p>

## Section H



Product Index .....	H2-H3	In-line Flow Control Valves .....	H12-H15
Compact Flow Control Valves .....	H4-H5	Compact Metal Flow Control Valves.....	H16-H17
Miniature Flow Control Valves .....	H6-H7	Check Valves .....	H18-H20
Swivel Outlet Flow Control Valves.....	H8-H9	Blocking Flow Controls Valves.....	H22-H23
Plug-in Flow Control Valves.....	H10-H11	Threshold Sensor .....	H24-H25

<b>H</b>
Product Index
Compact Flow Controls
Miniature Flow Controls
Swivel Flow Controls
Plug-in Flow Controls
In-Line Flow Controls
Metal Flow Controls
Check Valves
Blocking Valves
Threshold Sensors

<b>Compact Flow Control Valves</b>	<b>FCC731</b> Meter Out  Page H4	<b>FCC731</b> Meter Out - BSPP  Page H4	<b>FCCB731</b> Bi-Directional Flow Control  Page H5	<b>FCCB731</b> Bi-directional Flow Control - BSPP  Page H5	<b>FCKC731</b> Knobless Meter Out Flow Control  Page H5	
	<b>FCKC731</b> Knobless Flow Control - BSPP  Page H5	<b>FCKCB731</b> Knobless Bi-directional Flow Control - BSPP  Page H5	<b>Miniature Flow Control Valves</b>	<b>FCM731</b> Meter Out Flow Control  Page H7	<b>FCM731</b> Flow Control - BSPP  Page H7	<b>FCMB731</b> Bi-directional Flow Control - BSPP  Page H7
	<b>FCMK731</b> Knobless Mini Meter Out Flow Control  Page H7	<b>Swivel Outlet Flow Control Valves</b>		<b>FCCS731</b> Compact Swivel Outlet Flow Control  Page H9	<b>FCMS731</b> Mini Swivel Outlet Flow Control  Page H9	<b>FCMS731</b> Miniature Swivel Outlet - BSPP  Page H9
<b>Plug-In Flow Control Valves</b>	<b>FCMSP731</b> Mini Flow Control  Page H11		<b>FCMSP701</b> Miniature Flow Control  Page H11	<b>FCCSP731</b> Compact Flow Control  Page H11	<b>In-Line Flow Control Valves</b>	<b>FC832</b> Flow Control  Page H13
	<b>FCB832</b> Bi-directional Flow Control  Page H13	<b>FC832</b> Flow Control  Page H13	<b>FCB832</b> Bi-directional Flow Control  Page H13	<b>FCPM832</b> Panel Mountable Flow Control  Page H13		<b>FC836</b> Threaded Flow Control  Page H13
<b>337 Series</b> Micrometer Flow Control Valves  Page H14	<b>337 Series</b> Micrometer Flow Control Valves - BSPP  Page H14	<b>338 Series</b> Bi-directional Flow Control Valves  Page H14	<b>338 Series</b> Bi-directional Flow Control Valves - BSPP  Page H14	<b>3250 Series</b> Flow Control Valves  Page H14	<b>3250 Series</b> Flow Control Valves - BSPP  Page H15	
<b>3250 Series</b> Flow Control Valves  Page H15	<b>3250 Series</b> Flow Control Valves - BSPP  Page H15	<b>Compact Metal Flow Control Valves</b>	<b>3251 Series</b> Right Angle Flow Control Valves  Page H17	<b>FC705</b> Push-to-Connect Metal Flow Control  Page H17	<b>FC701</b> Push-to-Connect Metal Flow Control - BSPP  Page H17	
<b>FC708</b> Threaded Port Meter Out Flow Control  Page H17	<b>FC702</b> Threaded Port Metal Flow Control - BSPP  Page H17		<b>Flow Control Check Valves</b>	<b>32PLCK</b> In-Line Check Valve  Page H19	<b>32PLCK</b> In-Line Check Valve  Page H19	<b>W68PLCK</b> Male Check Valve  Page H19

**H**

Product Index

Compact Flow Controls

Miniature Flow Controls

Swivel Flow Controls

Plug-In Flow Controls











In-Line Flow Controls

Metal Flow Controls

Check Valves

Blocking Valves

Threshold Sensors

<p><b>W68PLCKI</b>  Male Check Valve  Meter In</p>  <p>Page H19</p>	<p><b>68PLCK</b>  Male Check Valve  Meter Out - BSPP</p>  <p>Page H19</p>	<p><b>68PLCKI</b>  Male Check Valve  Meter In - BSPP</p>  <p>Page H19</p>	<p><b>VC</b>  Check Valve</p>  <p>Page H19</p>	<p><b>339 Series</b>  Check Valve</p>  <p>Page H20</p>	<p><b>339 Series</b>  Check Valve - BSPP</p>  <p>Page H20</p>	
<p><b>3047 Series</b>  Check Valve</p>  <p>Page H20</p>	<p><b>Blocking  Flow Control  Valves</b></p>		<p><b>FC601</b>  Push-to-Connect  Lock Out Valves</p>  <p>Page H23</p>	<p><b>FC601</b>  Push-to-Connect  Lock-Out Valve -  BSPP</p>  <p>Page H23</p>	<p><b>FC602</b>  Threaded Port  Lock Out Valves</p>  <p>Page H23</p>	<p><b>FC608</b>  Threaded Port  Lock-Out Valve -  BSPP</p>  <p>Page H23</p>
<p><b>Threshold  Sensor</b></p>		<p><b>PSBJ731</b>  Pneumatic -  5/32 Pilot</p>  <p>Page H25</p>	<p><b>PSBJ731</b>  Pneumatic -  4mm Pilot</p>  <p>Page H25</p>	<p><b>PSPJ731</b>  Pneumatic -  10-32 Pilot</p>  <p>Page H25</p>	<p><b>PSBJ708</b>  Pneumatic -  M5 Pilot</p>  <p>Page H25</p>	<p><b>PSPE701</b>  Pneumatic /  Electric - BSPP</p>  <p>Page H25</p>

<b>H</b>
Product Index
Compact Flow Controls
Miniature Flow Controls
Swivel Flow Controls
Plug-In Flow Controls
In-Line Flow Controls
Metal Flow Controls
Check Valves
Blocking Valves
Threshold Sensors

Features

Materials Of Construction	
Body (Depending upon the Model):	<ul style="list-style-type: none"> <li>• Glass reinforced nylon 6.6</li> <li>• Brass</li> </ul>
Gripping Ring:	Stainless Steel
Adjustment Screws	Nickel-plated brass
Locking Nut:	Nickel-plated brass
Base:	Nickel-plated brass

Nomenclature	
Example:FCC731-4-2	Attribute:
FC	Flow control
C	Compact
7	Right angle
3	Nylon body
1	Tube x Pipe
4	1/4 Tube O.D.
2	1/8 Pipe thread

Applicable Tube	
Tube O.D.	1/8, 5/32, 1/4, 3/8
Tube O.D. (mm)	4, 6, 8, 10, 12

Specifications	
Pressure Range:	15 to 145 PSI
Temperature Ranges:	30° to 160°F
Working Fluid:	Compressed air



Compact flow control regulators ensure excellent performance of flow and are perfectly suited for reduced spaces due to their small size. The sensitivity of the adjustment screw provides very precise air flow control and regulation. A locking nut guarantees stability of adjustment against vibration tampering of the flow setting.

H

Product Index

Compact Flow Controls

Miniature Flow Controls

Swivel Flow Controls

Plug-In Flow Controls

In-Line Flow Controls

Metal Flow Controls

Check Valves

Blocking Valves

Threshold Sensors

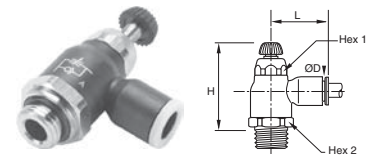
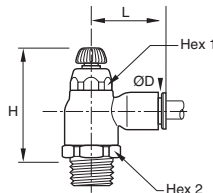

FCC731 Compact Meter Out

Part No.	Tube Size (In)	NPT	Hex 1 (In)	Hex 2 (In)	H Open	H Closed	L
FCC731-5/32-2	5/32	1/8	0.63	0.39	1.67	1.44	0.85
FCC731-5/32-4	5/32	1/4	0.63	0.39	1.67	1.44	0.85
FCC731-4-2	1/4	1/8	0.63	0.39	1.67	1.44	0.85
FCC731-4-4	1/4	1/4	0.63	0.39	1.67	1.44	0.85
FCC731-6-4	3/8	1/4	0.91	0.67	2.03	1.71	1.22
FCC731-6-6	3/8	3/8	0.91	0.67	2.03	1.71	1.22

FCC731 Compact Meter Out - BSPT

Part No.	Tube Size (mm)	BSPT	Hex 1 (mm)	Hex 2 (mm)	H Closed	H Open	L
FCC731-4M-2G	4	1/8	10	16	38.0	44.0	22.0
FCC731-6M-2G	6	1/8	10	16	38.0	44.0	22.0
FCC731-6M-4G	6	1/4	10	16	36.5	42.5	22.0
FCC731-8M-2G	8	1/8	14	19	41.5	48.0	28.0
FCC731-8M-4G	8	1/4	14	19	41.5	48.0	28.0
FCC731-8M-6G	8	3/8	14	19	41.5	48.0	28.0
FCC731-10M-4G	10	1/4	17	23	45.5	53.5	31.5
FCC731-10M-6G	10	3/8	17	23	45.5	54.0	31.5
FCC731-12M-6G	12	3/8	17	23	45.5	54.0	35.0
FCC731-12M-8G	12	1/2	17	24	45.5	54.0	35.0



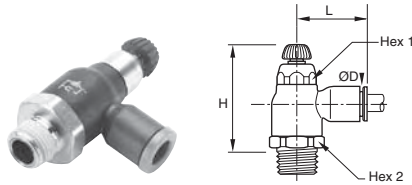

**FCCB731 Compact Bi-Directional Flow Control**

Part No.	Tube Size (In)	NPT	Hex 1 (In)	Hex 2 (In)	H Open	H Closed	L
FCCB731-5/32-2	5/32	1/8	0.63	0.39	1.67	1.44	0.85
FCCB731-4-2	1/4	1/8	0.63	0.39	1.67	1.44	0.85
FCCB731-4-4	1/4	1/4	0.63	0.39	1.67	1.44	0.85

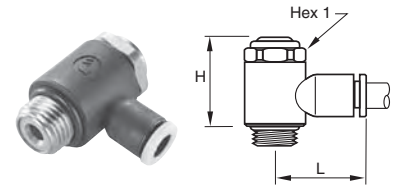

**FCKC731 Knobless Compact Flow Control - BSPP**

Part No.	Tube Size (mm)	BSPP / M5	Hex 1 (mm)	H	L
FCKC731-4M-M5	4	M5X0.8	8.0	17.5	17.0
FCKC731-4M-2G	4	1/8	13.0	25.0	19.0
FCKC731-6M-M5	6	M5X0.8	8.0	17.5	19.0
FCKC731-6M-2G	6	1/8	13.0	25.0	21.0
FCKC731-6M-4G	6	1/4	17.0	26.5	22.0
FCKC731-8M-2G	8	1/8	13.0	25.0	26.0
FCKC731-8M-4G	8	1/4	17.0	26.5	27.0
FCKC731-8M-6G	8	3/8	20.0	37.5	29.0
FCKC731-10M-4G	10	1/4	17.0	26.5	29.0
FCKC731-10M-6G	10	3/8	20.0	37.5	31.0
FCKC731-10M-8G	10	1/2	23.0	43.0	37.0
FCKC731-12M-6G	12	3/8	20.0	37.5	6.8
FCKC731-12M-8G	12	1/2	23.0	43.0	37.0

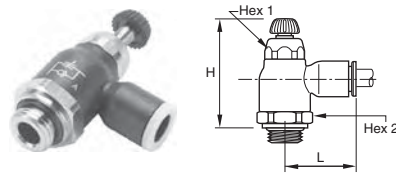

**FCCB731 Compact Bi-directional Flow Control - BSPP**

Part No.	Tube Size (mm)	BSPP	Hex 1 (mm)	Hex 2 (mm)	H Closed	H Open	L
FCCB731-4M-2G	4	1/8	10	16	38.0	44.0	22.0
FCCB731-6M-2G	6	1/8	10	16	38.0	44.0	22.0
FCCB731-6M-4G	6	1/4	10	16	36.5	42.5	22.0
FCCB731-8M-2G	8	1/8	14	19	41.5	48.0	28.0
FCCB731-8M-4G	8	1/4	14	19	41.5	48.0	28.0
FCCB731-8M-6G	8	3/8	14	19	41.5	48.0	28.0

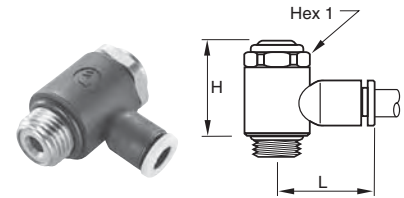

**FCKCB731 Knobless Bi-directional Flow Control - BSPP**

Part No.	Tube Size (mm)	BSPP / M5	Hex 1 (mm)	H	L
FCKCB731-4M-M5	4	M5X0.8	8	17.5	17.0
FCKCB731 -4M-2G	4	1/8	13	25.0	19.0
FCKCB731 -6M-M5	6	M5X0.8	8	17.5	19.0
FCKCB731 -6M-2G	6	1/8	13	25.0	21.0
FCKCB731 -6M-4G	6	1/4	17	26.5	22.0
FCKCB731 -8M-2G	8	1/8	13	25.0	26.0
FCKCB731 -8M-4G	8	1/4	17	26.5	27.0
FCKCB731 -8M-6G	8	3/8	20	37.5	29.0

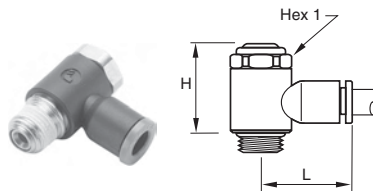

**FCKC731 Knobless Meter Out Flow Control**

Part No.	Tube Size (In)	NPT / UNF	Hex 1 (mm)	H	L
FCKC731-2-0	1/8	10-32		0.69	0.65
FCKC731-2-2	1/8	1/8	13	0.79	0.75
FCKC731-5/32-0	5/32	10-32		0.69	0.65
FCKC731-5/32-2	5/32	1/8	13	0.79	0.75
FCKC731-4-0	1/4	10-32		0.69	0.77
FCKC731-4-2	1/4	1/8	13	0.79	0.85
FCKC731-4-4	1/4	1/4	17	1.04	0.89
FCKC731-5-2	5/16	1/8	13	0.79	1.02
FCKC731-5-4	5/16	1/4	17	1.04	1.06
FCKC731-6-4	3/8	1/4	17	1.04	1.14
FCKC731-6-6	3/8	3/8	20	1.14	1.36

**Features**

Materials of Construction	
Body (Depending upon the Model):	<ul style="list-style-type: none"> <li>• Glass reinforced nylon 6.6</li> <li>• Brass</li> </ul>
Gripping Ring:	Stainless Steel
Adjustment Screws	Nickel-plated brass
Locking Nut:	Nickel-plated brass
Base:	Nickel-plated brass

Nomenclature	
Example: FCM731-4-2	Attribute:
FC	Flow control
M	Miniature
7	Right angle
3	Nylon body
1	Tube x pipe
4	1/4 Tube O.D.
2	1/8 Pipe thread

Applicable Tube	
Tube O.D.	1/8, 5/32, 1/4
Tube O.D. (mm)	3, 4, 6, 8

Specifications	
Pressure Range:	15 to 145 PSI
Temperature Ranges:	30° to 160°F
Working Fluid:	Compressed air



The miniature flow control regulator is especially adapted for all very small sized pneumatic applications (micro-pneumatic in particular). They are specifically designed for use with small bore cylinders (pancake / flat cylinders). Miniature flow control regulators are available in meter out, meter in and bi-directional versions.

**H**

Product Index

Compact Flow Controls

Miniature Flow Controls

Swivel Flow Controls

Plug-In Flow Controls

In-Line Flow Controls

Metal Flow Controls

Check Valves

Blocking Valves

Threshold Sensors

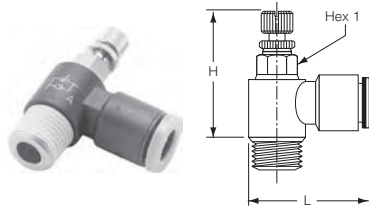

**FCM731 Miniature Meter Out Flow Control**

Part No.	Tube Size (In)	NPT	Hex 1 mm	H Open	H Closed	L
FCM731-2-0	1/8	10-32	6	1.14	0.91	0.67
FCM731-2-2	1/8	1/8	7	1.41	1.26	0.69
FCM731-5/32-0	5/32	10-32	6	1.02	0.93	0.67
FCM731-5/32-2	5/32	1/8	7	1.16	1.06	0.71
FCM731-4-0	1/4	10-32	6	1.02	0.93	0.73
FCM731-4-2	1/4	1/8	7	1.16	1.06	0.75
FCM731-4-4	1/4	1/4	8	1.28	1.18	0.77

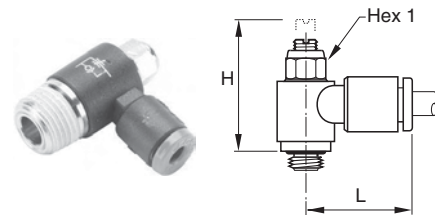

**FCMK731 Knobless Mini Meter Out Flow Control**

Part No.	Tube Size (In)	NPT	Hex 1 mm	H Open	H Closed	L
FCMK731-2-0	1/8	10-32	6	0.79	0.65	0.65
FCMK731-2-2	1/8	1/8	6	0.85	0.71	0.71
FCMK731-5/32-0	5/32	10-32	6	0.79	0.65	0.65
FCMK731-5/32-2	5/32	1/8	6	0.85	0.71	0.71
FCMK731-4-0	1/4	10-32	6	0.79	0.65	0.65
FCMK731-4-2	1/4	1/8	6	0.85	0.71	0.73
FCMK731-4-4	1/4	1/4	6	0.97	0.83	0.73

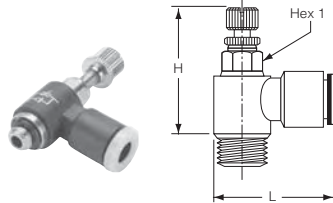

**FCM731 Miniature Flow Control - BSPP**

Part No.	Tube Size (mm)	BSPP	Hex 1	H Closed	H Open	L
FCM731-3M-M3	3	M3X0.5	6	23.5	26.0	17.0
FCM731-3M-M5	3	M5X0.8	6	23.5	26.0	17.0
FCM731-4M-M3	4	M3X0.5	6	23.5	26.0	16.5
FCM731-4M-M5	4	M5X0.8	6	23.5	26.0	17.0
FCM731-4M-2G	4	1/8	7	27.0	29.5	18.0
FCM731-6M-M5	6	M5X0.8	6	23.5	26.0	18.0
FCM731-6M-2G	6	1/8	7	27.0	29.5	18.5
FCM731-6M-4G	6	1/4	8	30.0	32.5	19.0
FCM731-8M-2G	8	1/8	13	26.5	31.0	26.0
FCM731-8M-4G	8	1/4	16	29.0	34.0	27.5
FCM731-8M-6G	8	3/8	20	36.0	42.0	29.0

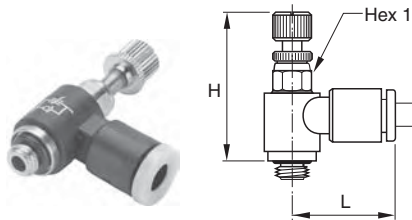

**FCMB731 Miniature Bi-directional Flow Control - BSPP**

Part No.	Tube Size (mm)	BSPP	Hex 1	H Closed	H Open	L
FCMB731-4M-M5	4	M5X0.8	6	23.5	26.0	16.5
FCMB731-4M-2G	4	1/8	7	27.0	29.5	17.0
FCMB731-6M-M5	6	M5X0.8	6	23.5	26.0	18.0
FCMB731-6M-2G	6	1/8	7	27.0	29.5	18.0
FCMB731-6M-4G	6	1/4	8	30.0	32.5	18.5

H

Product Index

Compact Flow Controls

Miniature Flow Controls

Swivel Flow Controls

Plug-In Flow Controls

In-Line Flow Controls

Metal Flow Controls

Check Valves

Blocking Valves

Threshold Sensors

Features

Materials of Construction	
Body:	Glass reinforced nylon 6.6
Gripping Ring:	Stainless Steel
Adjustment Screws	Nickel-plated brass
Locking Nut:	Nickel-plated brass
Base:	Nickel-plated brass

Nomenclature	
Example: FCMS731-5/32-2	Attribute:
FC	Flow control
M	Miniature
S	Swivel outlet
7	Right angle
3	Nylon body
1	Tube x pipe
5/32	5/32 Tube O.D.
2	1/8 Pipe thread

Applicable Tube	
Tube O.D.	5/32, 1/4, 3/8
Tube O.D. (mm)	4, 6, 8, 10, 12

Specifications	
Pressure Range:	15 to 145 PSI
Temperature Ranges:	30° to 160°F
Working Fluid:	Compressed air



Flow control regulators with “swivel outlet” are especially designed to allow a vertical or angled tube exit where access is restricted. The swivel outlet comes with instant push-in connection to ease installation. Flow control regulators with swivel outlet are available in meter out and meter in versions.

H

Product Index
Compact Flow Controls
Miniature Flow Controls
Swivel Flow Controls
Plug-In Flow Controls
In-Line Flow Controls
Metal Flow Controls
Check Valves
Blocking Valves
Threshold Sensors

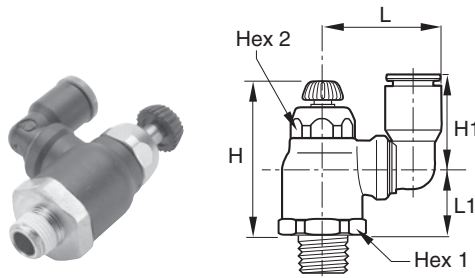

**FCCS731 Compact Swivel Outlet Flow Control**

Part No.	Tube Size (In)	NPT	Hex 1 mm	Hex 2 mm	H Closed	H Open	H1	L	L1
FCCS731-4-2	1/4	1/8	19	10	1.87	2.09	0.63	0.93	0.65
FCCS731-4-4	1/4	1/4	19	14	1.79	1.99	0.73	1.00	0.89
FCCS731-6-4	3/8	1/4	23	17	1.93	2.20	1.04	1.34	0.97
FCCS731-6-6	3/8	3/8	23	17	1.93	2.20	1.04	1.34	0.97

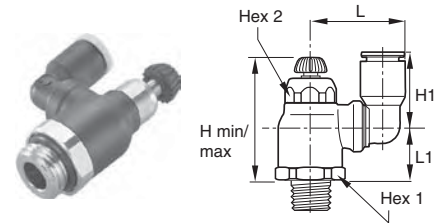

**FCCS731 Compact Swivel Outlet - BSPP**

Part No.	Tube Size (mm)	BSPP	Hex 1 mm	Hex 2 mm	H Closed	H Open	H1	L	L1
FCCS731-6M-2G	6	1/8	16	10	38.0	44.0	16.0	23.5	18.0
FCCS731-6M-4G	6	1/4	16	10	36.5	42.5	16.0	23.5	16.5
FCCS731-8M-2G	8	1/8	19	14	41.5	48.0	23.0	28.0	19.0
FCCS731-8M-4G	8	1/4	19	14	41.5	48.0	23.0	28.0	19.5
FCCS731-8M-6G	10	3/8	19	14	41.5	48.0	23.0	28.0	17.5
FCCS731-10M-4G	10	1/4	23	17	45.5	53.5	26.5	35.0	21.0
FCCS731-10M-6G	10	3/8	23	17	45.5	54.0	26.5	35.0	21.5
FCCS731-12M-6G	12	3/8	23	17	45.5	54.0	31.0	38.0	21.5
FCCS731-12M-8G	12	1/2	23	17	45.5	54.0	31.0	38.0	21.0

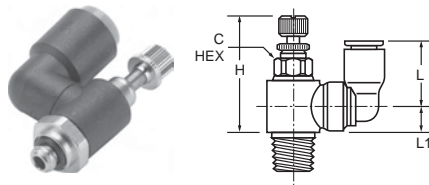

**FCMS731 Mini Swivel Outlet Flow Control**

Part No.	Tube Size (In)	NPT	Hex 1 mm	H Closed	H Open	H1	L	L1
FCMS731-5/32-0	5/32	10-32	6	0.96	1.08	0.55	0.73	0.26
FCMS731-5/32-2	5/32	1/8	8	1.08	1.20	0.55	0.73	0.33

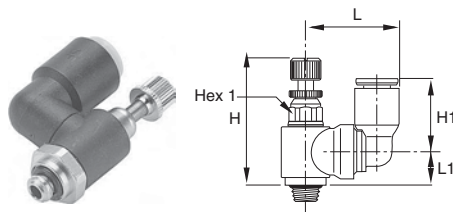

**FCMS731 Miniature Swivel Outlet - BSPP**

Part No.	Tube Size (mm)	BSPP	Hex 1 mm	H Closed	H Open	H1	L	L1
FCMS731-4M-M5	4	M5X0.8	6	24.5	27.5	14.5	19.5	6.5
FCMS731-4M-2G	4	1/8	7	27.5	31.0	14.5	20.0	8.5
FCMS731-6M-M5	6	M5X0.8	6	24.5	27.5	16.0	21.5	6.5
FCMS731-6M-2G	6	1/8	7	27.5	31.0	16.0	22.0	8.5

**H**

Product Index

Compact Flow Controls

Miniature Flow Controls

Swivel Flow Controls

Plug-In Flow Controls

In-Line Flow Controls

Metal Flow Controls

Check Valves

Blocking Valves

Threshold Sensors

**Features**

Materials of Construction	
Body:	Glass reinforced nylon 6.6
Gripping Ring:	Stainless Steel
Adjustment Screws	Nickel-plated brass
Locking Nut:	Nickel-plated brass
Tailpiece:	Nickel-plated brass

Nomenclature	
Example: FCMS731-5/32-2	Attribute:
FC	Flow control
M	Miniature
7	Right angle
3	Nylon body
1	Tube x pipe
4	1/4 Tube O.D.
2	1/8 Pipe thread

Applicable Tube	
Tube O.D.	1/8, 5/32, 1/4
Tube O.D. (mm)	4, 6, 8, 10, 12

Specifications	
Pressure Range:	15 to 145 PSI
Temperature Ranges:	30° to 160°F
Working Fluid:	Compressed air



Plug-in flow control regulators can be directly mounted into existing fittings and allow very compact installations. They are particularly suited for mounting in manifolds using cartridges. Their design and function give equal performance to that of flow control regulators with threaded connections.

<b>H</b>	Product Index
	Compact Flow Controls
	Miniature Flow Controls
	Swivel Flow Controls
	Plug-In Flow Controls
	In-Line Flow Controls
	Metal Flow Controls
	Check Valves
	Blocking Valves
	Threshold Sensors

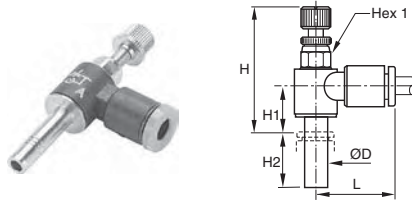

**FCMS731 Plug-In Mini Flow Control**

Part No.	Tube Size (In)	Hex 1 mm	H Open	H Closed	H1	H2	L
FCMS731-2	1/8	6	1.04	0.94	0.12	0.59	0.67
FCMS731-5/32	5/32	6	1.10	1.00	0.37	0.61	0.67
FCMS731-4	1/4	7	1.18	1.08	0.12	0.73	0.73

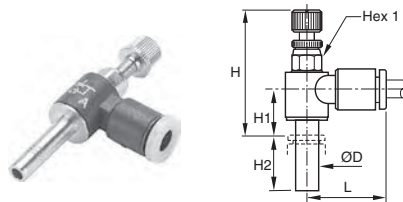

**FCMS701 - Plug-In Miniature Flow Control**

Part No.	Tube Size (mm)	Hex 1 mm	H Closed	H Open	H1	H2	L
FCMS701-4M	4	6	25.5	28.0	9.5	15.5	17.0
FCMS701-6M	6	7	27.5	29.0	10.5	17.0	18.5

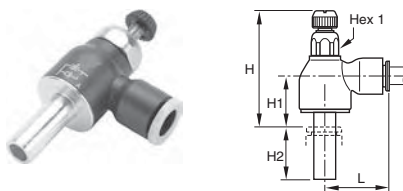

**FCCSP731 Plug-In Compact Flow Control**

Part No.	Tube Size (mm)	Hex 1 mm	H Closed	H Open	H1	H2	L
FCCSP731-6M	6	10	35.0	41.0	14.0	17.0	22.0
FCCSP731-8M	8	14	39.5	46.5	16.0	21.5	28.0
FCCSP731-10M	10	17	43.5	51.5	17.5	24.5	31.5
FCCSP731-12M	12	17	43.0	51.0	17.0	27.0	31.5

H

Product Index

Compact Flow Controls

Miniature Flow Controls

Swivel Flow Controls

Plug-In Flow Controls

In-Line Flow Controls

Metal Flow Controls

Check Valves

Blocking Valves

Threshold Sensors

Features

Materials of Construction	
Body:	Glass reinforced nylon 6.6
Gripping Ring:	Stainless Steel
Adjustment Screws	Nickel-plated brass
Locking Nut:	Nickel-plated brass
Tailpiece:	Nickel-plated brass

Nomenclature	
Example: FCMS731-5/32-2	Attribute:
FC	Flow control
M	Miniature
8	In-line
3	Nylon body
2	Tube x pipe
4	1/4 Tube O.D.

Applicable Tube	
Tube O.D.	5/32, 1/4, 5/16, 3/8, 1/2
Tube O.D. (mm)	4, 6, 8, 10, 12

Specifications	
Pressure Range:	15 to 145 PSI
Temperature Ranges:	30° to 160°F
Working Fluid:	Compressed air

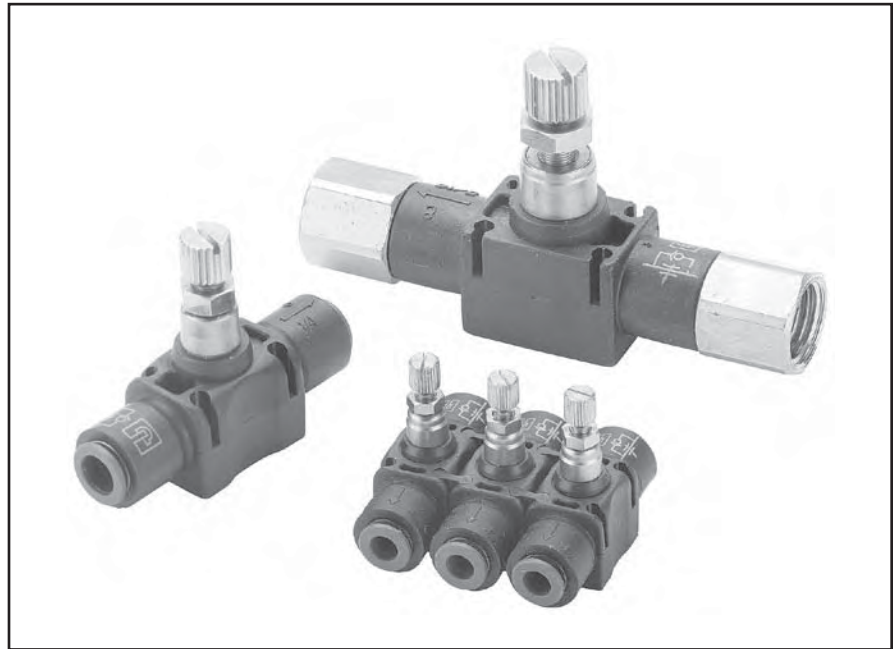

In-line flow controls are unidirectional flow control valves. Intake air flows freely through the flow control; exhaust air is metered out through a specially designed adjustment screw. An arrow on the body of the valve indicates the direction of controlled flow. They can be easily added to existing circuitry. Simply splice it into the cylinder port line.

They can be used individually or they may be stacked together using two joining clips.

<b>H</b>	Product Index
	Compact Flow Controls
	Miniature Flow Controls
	Swivel Flow Controls
	Plug-In Flow Controls
	In-Line Flow Controls
	Metal Flow Controls
	Check Valves
	Blocking Valves
	Threshold Sensors

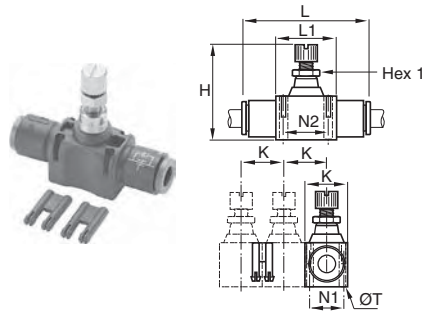

**FC832 In-Line Flow Control**

Part No.	Tube Size (In)	Hex 1 mm	H Closed	H Open	K	L	L1	N1	N2	T
FC832-5/32	5/32	5	1.15	1.31	0.47	1.52	0.59	0.31	0.43	0.09
FC832-4	1/4	8	1.54	1.74	0.66	2.00	0.90	0.43	0.66	0.12
FC832-5	5/16	11	1.73	1.97	0.73	2.38	1.02	0.49	0.79	0.13
FC832-6	3/8	14	2.03	2.38	0.94	2.87	1.29	0.62	1.01	1.60
FC832-8	1/2	14	2.24	2.63	1.09	3.35	1.37	0.78	1.07	0.16

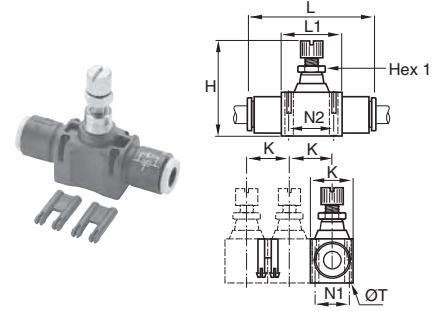

**FCB832 In-Line Bi-directional Flow Control**

Part No.	Tube Size (mm)	Hex 1 mm	H Closed	H Open	K	L	L1	N1	N2	T
FCB832-4M	4	5	29.5	33.5	12.0	39.0	15.0	8.0	11.0	2.2
FCB832-6M	6	8	39.5	44.5	17.0	54.0	23.0	11.0	17.0	3.2
FCB832-8M	8	11	44.0	50.0	18.5	60.5	26.0	12.5	20.0	3.2

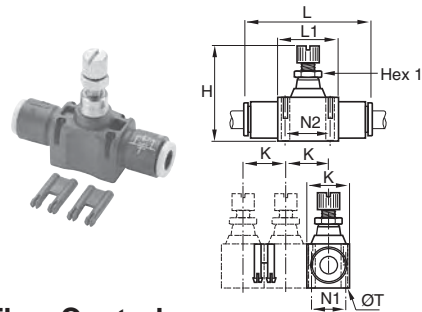

**FC832 In-Line Flow Control**

Part No.	Tube Size (mm)	Hex 1 mm	H Closed	H Open	K	L	L1	N1	N2	T
FC832-4M	4	5	29.5	33.5	12.0	39.0	15.0	8.0	11.0	2.2
FC832-6M	6	8	39.5	44.5	17.0	54.0	23.0	11.0	17.0	3.2
FC832-8M	8	11	44.0	50.0	18.5	60.5	26.0	12.5	20.0	3.2
FC832-10M	10	14	52.0	61.0	24.0	76.0	33.0	16.0	26.0	4.2
FC832-12M	12	14	57.5	67.5	28.0	86.0	35.0	20.0	27.5	4.2

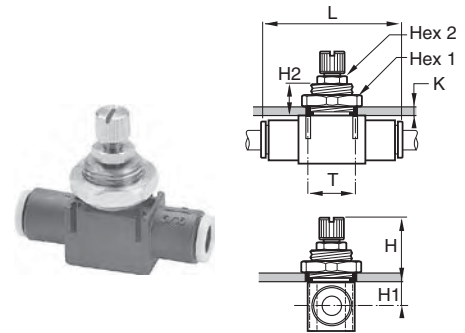

**FCPM832 In-Line Panel Mountable Flow Control**

Part No.	Tube Size (mm)	Hex 1 (mm)	Hex 2 (mm)	H Closed	H Open	K	L	H1	H2	T
FCPM832-4M	4	14		21.5	25.5	6.0	39.0	6.5	11.0	10.5
FCPM832-6M	6	19		27.5	32.5	7.0	54.0	7.5	13.5	16.5
FCPM832-8M	8	24	11	28.5	34.5	7.0	60.5	9.0	13.5	18.5
FCPM832-10M	10	30	14	29.5	38.5	7.0	76.0	11.5	13.5	24.5
FCPM832-12M	12	32	14	32.0	42.0	8.0	86.0	12.5	15.5	27.5

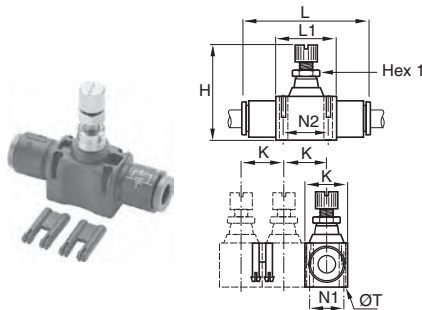

**FCB832 In-Line Bi-directional Flow Control**

Part No.	Tube Size (In)	Hex 1 mm	H Closed	H Open	K	L	L1	N1	N2	T
FCB832-5/32	5/32	5	1.15	1.31	0.47	1.52	0.59	0.31	0.43	0.09
FCB832-4	1/4	8	1.54	1.74	0.66	2.00	0.90	0.43	0.66	0.12
FCB832-5	5/16	11	1.73	1.97	0.73	2.38	1.02	0.49	0.79	0.13

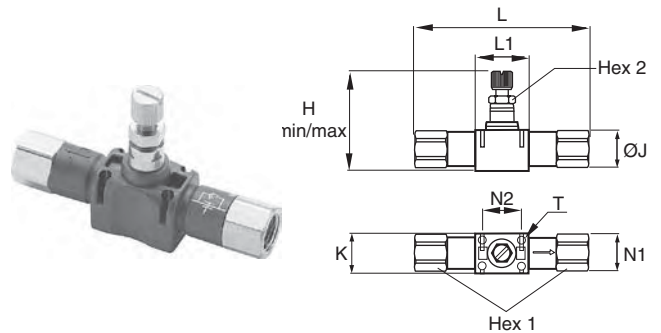

**FC836 Threaded In-Line Flow Control**

Part No.	NPT	Hex 1 (mm)	Hex 2 (mm)	H Closed	H Open	K	L	L1	N1	N2	T
FC836-2	1/8	13	8.00	1.56	1.75	0.67	2.70	0.91	0.43	0.67	0.12
FC836-4	1/4	16	11.00	1.73	1.97	0.73	3.27	1.02	0.49	0.79	0.12
FC836-6	3/8	22	14.00	2.05	2.40	0.94	3.82	1.30	0.63	1.02	0.16
FC836-8	1/2	24	14.00	2.26	2.66	1.10	4.76	1.38	0.79	1.08	0.16

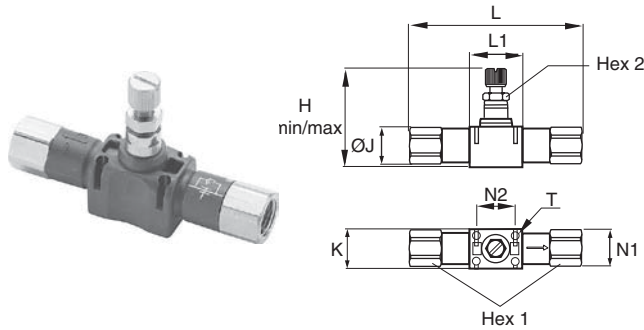

**FC836 Threaded In-Line Flow Control - BSPP**

Part No.	BSPP	Hex 1 (mm)	Hex 2 (mm)	H Closed	H Open	K	L	N1	N2	T
FC836-2G	1/8"	13	8	39.5	44.5	17.0	68.5	11.0	17.0	3.2
FC836-4G	1/4"	16	11	44.0	50.0	18.5	83.0	12.5	20.0	3.2
FC836-6G	3/8"	19	14	52.0	61.0	24.0	97.0	16.0	26.0	4.2
FC836-8G	1/2"	24	14	57.5	67.5	28.0	121.0	20.0	27.5	4.2

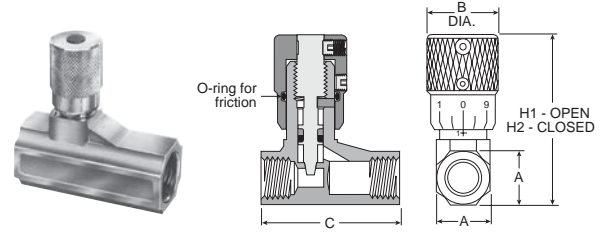

**338 Bi-directional Flow Control Valves**

Part No.	Port Size	A	B	C	H1	H2
00338 1100	1/8"	9/16"	0.75	1.47	2.03	1.81
00338 1101	1/4"	11/16"	0.75	1.47	2.28	2.03
00338 1102	3/8"	7/8"	0.88	2.31	2.84	2.53
00338 1103	1/2"	1-3/16"	1.06	3.25	3.62	3.22
00338 1104	3/4"	1-3/8"	1.06	3.25	3.72	3.31

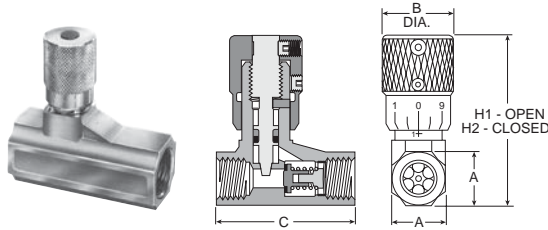

**337 Micrometer Flow Control Valves**

Part No.	Port Size	A	B	C	H1	H2
00337 1000	1/8"	9/16"	0.75	1.47	2.03	1.81
00337 1001	1/4"	11/16"	0.75	1.47	2.28	2.03
00337 1002	3/8"	7/8"	0.88	2.31	2.84	2.53
00337 1003	1/2"	1-3/16"	1.06	3.25	3.62	3.22
00337 1004	3/4"	1-3/8"	1.06	3.25	3.72	3.31

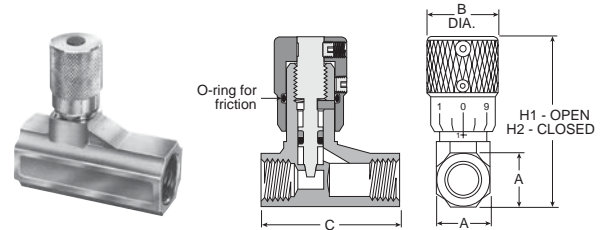

**338 Bi-directional Flow Control Valves - BSPP**

Part No.	Port Size	A	B	C	H1	H2
00338G1100	1/8"	9/16"	0.75	1.47	2.03	1.81
00338G1101	1/4"	11/16"	0.75	1.47	2.28	2.03

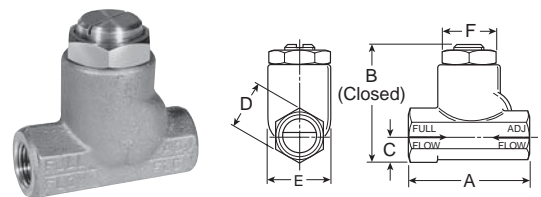

**3250 Flow Control Valves**

Part No.	Port Size	A	B	C	D	E	F
03250 0119	1/8"	1.75	1.56	0.37	0.62	0.81	0.68
03250 0219	1/4"	2.33	1.97	0.44	0.75	1.09	0.94
03250 0319	3/8"	2.66	2.44	0.56	1.00	1.38	1.19
03250 0419	1/2"	3.11	3.06	0.75	1.25	1.63	1.38
03250 0519	3/4"	3.56	3.69	0.88	1.50	2.00	1.75

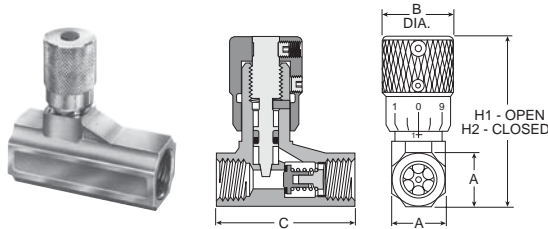

**337 Micrometer Flow Control Valves - BSPP**

Part No.	Port Size	A	B	C	H1	H2
00337G1000	1/8"	9/16"	0.75	1.47	2.03	1.81
00337G1001	1/4"	11/16"	0.75	1.47	2.28	2.03

H

Product Index

Compact Flow Controls

Miniature Flow Controls

Swivel Flow Controls

Plug-In Flow Controls

In-Line Flow Controls

Metal Flow Controls

Check Valves

Blocking Valves

Threshold Sensors

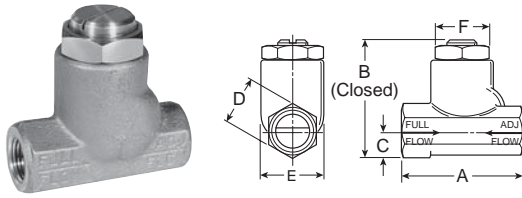

**3250 Flow Control Valves - BSPP**

Part No.	Port Size	A	B	C	D	E	F
3250G0119	1/8"	1.75	1.56	0.37	0.62	0.81	0.68
3250G0219	1/4"	2.33	1.97	0.44	0.75	1.09	0.94
3250G0319	3/8"	2.66	2.44	0.56	1.00	1.38	1.19
3250G0419	1/2"	3.11	3.06	0.75	1.25	1.63	1.38
3250G0519	3/4"	3.56	3.69	0.88	1.50	2.00	1.75

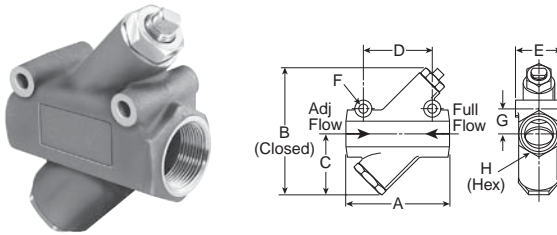

**3250 Flow Control Valves**

Part No.	Port Size	A	B	C	D	E	F	G	H
03250 1000	1"	5.00	6.50	3.00	3.25	2.25	.39	1.31	2.13
03250 1250	1-1/4"	5.00	6.50	3.00	3.25	2.25	.39	1.31	2.13
03250 1500	1-1/2"	5.88	8.00	3.75	3.50	2.50	.39	1.50	2.38

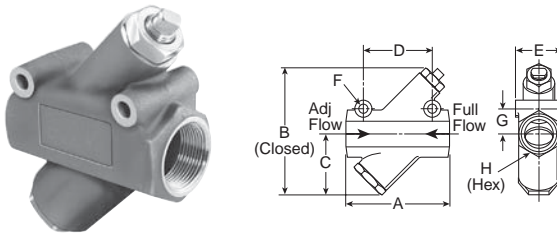

**3250 Flow Control Valves - BSPP**

Part No.	Port Size	A	B	C	D	E	F	G	H
3250G1000	1"	5.00	6.50	3.00	3.25	2.25	.39	1.31	2.13
3250G1250	1-1/4"	5.00	6.50	3.00	3.25	2.25	.39	1.31	2.13
3250G1500	1-1/2"	5.88	8.00	3.75	3.50	2.50	.39	1.50	2.38

H
Product Index
Compact Flow Controls
Miniature Flow Controls
Swivel Flow Controls
Plug-In Flow Controls
In-Line Flow Controls
Metal Flow Controls
Check Valves
Blocking Valves
Threshold Sensors

**Features**

Materials of Construction	
Body:	Treated Brass
Gripping Ring:	Stainless Steel
Adjustment Screws	Nickel-plated brass
Locking Nut:	Nickel-plated brass
Tailpiece:	Nickel-plated brass

Nomenclature	
Example: FCMS731-5/32-2	Attribute:
FC	Flow control
7	Right angle
0	Brass body
1	Tube x pipe
4	1/4 Tube O.D.
2	1/8 Pipe thread

Applicable Tube	
Tube O.D.	1/8, 5/32, 1/4, 3/8
Tube O.D. (mm)	4, 6, 8, 10, 12, 14

Specifications	
Pressure Range:	15 to 145 PSI
Temperature Ranges:	30° to 160°F
Working Fluid:	Compressed air



Metal flow control regulators are suited for use in severe conditions (temperatures, sparks, abrasion, etc). The screw and locking nut have been designed for easy manipulation, by hand. Adjustment can be made with a screwdriver and locking by use of a wrench.

**H**

Product Index

Compact Flow Controls

Miniature Flow Controls

Swivel Flow Controls

Plug-In Flow Controls

In-Line Flow Controls

Metal Flow Controls

Check Valves

Blocking Valves

Threshold Sensors

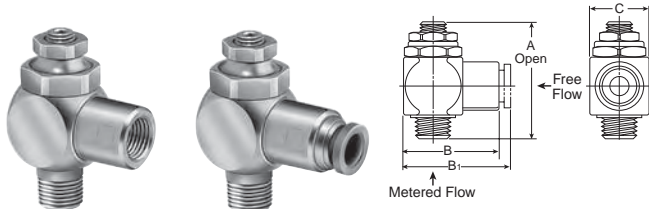

Shown with Threaded Inlet

Shown with Prestolok Inlet Fitting

Model Number	Thread (NPT) Male	Thread (NPT) Female	A mm	B mm	C mm	Weight kg.	Cv	
							Adjusted Flow	Free Flow
03251 0125	1/8	1/8	44	30	17	0.9	0.26	0.20
03251 0250	1/4	1/4	51	36	23	2.0	0.75	0.68
03251 0375	3/8	3/8	58	43	27	3.2	0.84	0.72
03251 0500	1/2	1/2	68	53	32	5.0	1.64	1.41
<b>With Prestolok Fittings</b>								
03251 1215	1/8	5/32	44	30	17	0.9	0.19	0.16
03251 1225	1/8	1/4	44	30	17	0.9	0.28	0.22
03251 2525	1/4	1/4	51	36	23	2.0	0.51	0.44
03251 2538	1/4	3/8	51	36	23	2.0	0.62	0.53
03251 3838	3/8	3/8	58	43	27	3.2	0.78	0.65

**CAUTION:** If it is possible that the ambient temperature may fall below freezing, the medium must be moisture-free to prevent internal damage or unpredictable behavior.

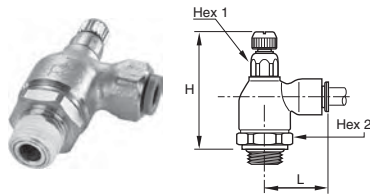

### FC705 Push-to-Connect Metal Flow Control

Part No.	Tube Size (in)	NPT	Hex 1 mm	Hex 2 mm	H Closed	H Open	L
FC705-5/32-2	5/32	1/8	19	10	1.79	2.01	0.85
FC705-4-2	1/4	1/8	19	10	1.79	2.01	0.97
FC705-4-4	1/4	1/4	19	10	1.79	2.01	0.97
FC705-6-4	3/8	1/4	19	14	1.91	2.11	1.14
FC705-6-6	3/8	3/8	25	17	2.15	2.40	1.40

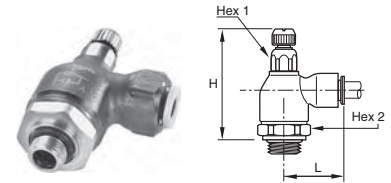

### FC701 Push-to-Connect Metal Flow Control - BSPP

Part No.	Tube Size (mm)	BSPP	Hex 1	Hex 2	H Closed	H Open	L
FC701-4M-2G	4	1/8	10	19	47.0	53.0	21.0
FC701-6M-2G	6	1/8	10	19	47.0	53.0	24.5
FC701-6M-4G	6	1/4	10	19	47.5	53.0	24.5
FC701-8M-2G	8	1/8	14	19	50.0	55.0	29.0
FC701-8M-4G	8	1/4	14	19	50.0	56.0	29.0
FC701-8M-6G	8	3/8	17	25	56.0	62.0	30.5
FC701-10M-4G	10	1/4	14	19	50.0	56.0	35.0
FC701-10M-6G	10	3/8	17	25	56.0	62.0	35.0
FC701-12M-6G	12	3/8	17	25	56.0	62.0	38.0
FC701-12M-8G	12	1/2	17	25	55.0	62.0	38.0
FC701-14M-8G	14	1/2	17	25	55.0	62.0	41.0

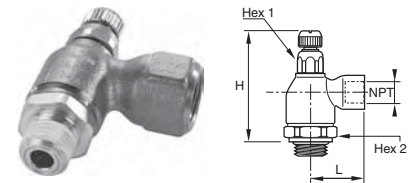

### FC708 Threaded Port Meter Out Flow Control

Part No.	NPT	Hex 1 mm	Hex 2 mm	H Closed	H Open	L	L1	L2
FC708-2	1/8	19	10	1.79	2.01	0.89	0.87	1.14
FC708-4	1/4	19	14	1.91	2.11	1.28	0.87	1.28
FC708-6	3/8	25	17	2.15	2.40	1.36	0.91	1.44
FC708-8	1/2	25	17	2.15	2.40	1.50	0.91	1.50

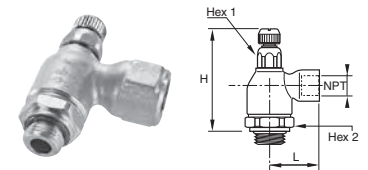

### FC702 Threaded Port Metal Flow Control - BSPP

Part No.	BSPP	Hex 1 mm	Hex 2 mm	H Closed	H Open	L
FC702-2G	1/8	10	19	47.0	52.5	22.5
FC702-4G	1/4	14	19	50.5	55.5	32.0
FC702-6G	3/8	17	25	56.0	62.0	34.5
FC702-8G	1/2	17	25	55.0	62.0	37.5

Features

Materials of Construction	
Body:	<ul style="list-style-type: none"> <li>• 32PLCK: Nylon/nickel plated brass</li> <li>• 68PLCK: Nylon body with nickel-plated brass base</li> <li>• VC: Acetal</li> </ul>
Gripping Ring:	Stainless Steel
O-Ring:	<ul style="list-style-type: none"> <li>• Nitrile (32PLCK &amp; 68PLCK)</li> <li>• EPDM (VC)</li> </ul>

Nomenclature	
Example: W68PLCK-4-2	Attribute:
W	White thread sealant
68	Tube x Pipe
PL	Prestolok
CK	Check Valve
4	1/4 Tube O.D.
2	1/8 Pipe thread

Nomenclature	
Example: A4VC4-MG	Attribute:
A	Acetal
4	1/4 Tube O.D.
VC	Valve, Check
4	1/4 Tube O.D.
MG	Metal gripping ring

Applicable Tube	
Tube O.D.	<ul style="list-style-type: none"> <li>• PLCK: 5/32, 1/4, 5/16, 3/8</li> <li>• VC: 1/4, 5/16, 3/8</li> </ul>
Tube O.D. (mm)	PLCK: 4, 6, 8, 10, 12

Specifications	
Pressure Range:	15 TO 145 PSI
Temperature Ranges:	34°F to 150°F
Cracking Pressure:	<ul style="list-style-type: none"> <li>• PLCK: 7 PSI</li> <li>• VC: 1/3 PSI</li> </ul>
Working Fluid:	Compressed air



These in-line check valves allows air to pass in one direction while blocking flow in the other direction. Their extreme compactness and light weight make them suitable as a safety item in compressed air circuits. The body of the fitting contains an arrow to indicate the direction of flow.

H

Product Index

Compact Flow Controls

Miniature Flow Controls

Swivel Flow Controls

Plug-In Flow Controls

In-Line Flow Controls

Metal Flow Controls

Check Valves

Blocking Valves

Threshold Sensors

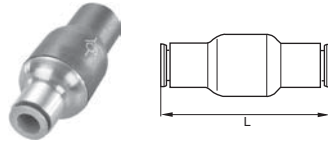

**32PLCK In-Line Check Valve**

Part No.	Tube Size (In)	L
32PLCK-5/32	5/32	1.52
32PLCK-4	1/4	1.61
32PLCK-5	5/16	2.03
32PLCK-6	3/8	2.50

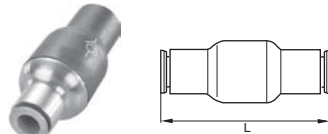

**32PLCK In-Line Check Valve**

Part No.	Tube Size (mm)	L
32PLCK-4M	4	38.5
32PLCK-6M	6	41.0
32PLCK-8M	8	51.5
32PLCK-10M	10	63.5
32PLCK-12M	12	66.5

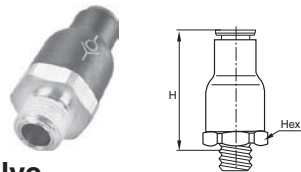

**W68PLCK Male Check Valve**

Part No.	Tube Size (in)	NPT / UNF	Hex (mm)	H
68PLCK-5/32-0	5/32	10-32	9	1.26
W68PLCK-5/32-2	5/32	1/8	16	1.12
W68PLCK-4-2	1/4	1/8	19	1.42
W68PLCK-4-4	1/4	1/4	19	1.42
W68PLCK-6-4	3/8	1/4	23	1.65
W68PLCK-6-6	3/8	3/8	23	1.65

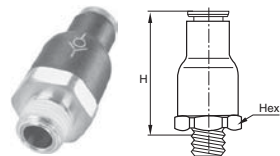

**W68PLCKI Male Check Valve Meter In**

Part No.	Tube Size (In)	NPT / UNF	Hex (mm)	H
68PLCKI-5/32-0	5/32	10-32	9	1.26
W68PLCKI-5/32-2	5/32	1/8	16	1.12
W68PLCKI-4-2	1/4	1/8	19	1.42
W68PLCKI-4-4	1/4	1/4	19	1.42
W68PLCKI-6-4	3/8	1/4	23	1.65
W68PLCKI-6-6	3/8	3/8	23	1.65

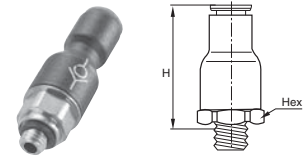

**68PLCK Male Check Valve Meter Out - BSPP**

Part No.	Tube Size (mm)	BSPP	Hex 1 (mm)	H
68PLCK-4M-M5	4	M5X0.8	9	32.0
68PLCK-4M-2G	4	1/8	16	28.5
68PLCK-6M-2G	6	1/8	16	30.5
68PLCK-6M-4G	6	1/4	16	30.5
68PLCK-8M-2G	8	1/8	19	36.0
68PLCK-8M-4G	8	1/4	19	36.0

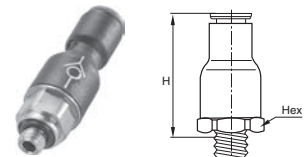

**68PLCKI Male Check Valve Meter In - BSPP**

Part No.	Tube Size (mm)	BSPP	Hex 1 (mm)	H
68PLCKI-4M-M5	4	M5X0.8	9	32.0
68PLCKI-6M-2G	6	1/8	16	30.5
68PLCKI-8M-2G	8	1/8	19	36.0
68PLCKI-8M-4G	8	1/4	19	36.0
68PLCKI-10M-6G	10	3/8	23	42.0
68PLCKI-12M-6G	12	3/8	23	42.0
68PLCKI-12M-8G	12	1/2	23	44.0

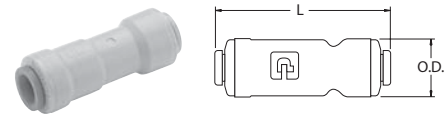

**VC - Check Valve**

Part No.	Tube Size (In)	L	O.D.
A4VC4-MG	1/4	2.00	.66
A5VC5-MG	5/16	2.10	.70
A6VC6-MG	3/8	2.15	.80

H

Product Index

Compact Flow Controls

Miniature Flow Controls

Swivel Flow Controls

Plug-In Flow Controls

In-Line Flow Controls

Metal Flow Controls

Check Valves

Blocking Valves

Threshold Sensors

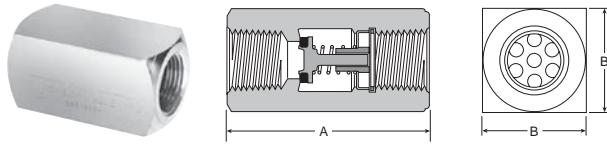

**339 Check Valve**

Part No.	Port Size	A	B
00339 3000	1/8"	1.22	0.56
00339 3001	1/4"	1.34	0.69
00339 3002	3/8"	2.00	0.88
00339 3003	1/2"	2.56	1.19
00339 3004	3/4"	2.66	1.38

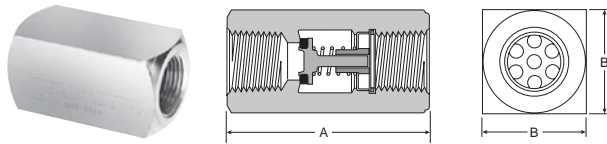

**339 Check Valve - BSPP**

Part No.	Port Size	A	B
00339G3000	1/8"	1.22	0.56
00339G3001	1/4"	1.34	0.69

**H**

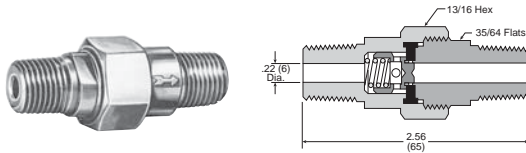

**3047 Check Valve**

Model Number	Pipe Thread
03047 0099	1/4"

- Product Index
- Compact Flow Controls
- Miniature Flow Controls
- Swivel Flow Controls
- Plug-In Flow Controls
- In-Line Flow Controls
- Metal Flow Controls
- Check Valves
- Blocking Valves
- Threshold Sensors

<b>H</b>
Product Index
Compact Flow Controls
Miniature Flow Controls
Swivel Flow Controls
Plug-In Flow Controls
In-Line Flow Controls
Metal Flow Controls
Check Valves
Blocking Valves
Threshold Sensors

Features

Materials of Construction	
Body:	Treated Brass
Gripping Ring:	Stainless Steel
Seals, Diaphragm:	Nitrile

Nomenclature	
Example: FC601-4-2	Attribute:
FC	Flow control
6	Blocking
0	Brass body
1	Tube x pipe
4	1/4 Tube O.D.
2	1/8 Pipe thread

Applicable Tube	
Tube O.D.	1/8, 5/32, 1/4, 3/8
Tube O.D. (mm)	4, 6, 8, 10, 12, 14

Specifications	
Pressure Range:	15 to 145 PSI
Temperature Ranges:	-4° to 160°F
Number of Cycles	> 10 million at 68°F and 1 Hz
Leak Rate:	< 3.2 CCM
Working Fluid:	Compressed air



Blocking valves prevents damage to work and equipment in the event of a loss of pressure. Blocking valves which are mounted in pairs on a cylinder lock the piston by simultaneously cutting off the supply and exhaust. Functional locks are more precise and rapid when blocking valves are located on the cylinder: the volume of air in the pipework no longer needs to be taken into consideration.

H

Product Index

Compact Flow Controls

Miniature Flow Controls

Swivel Flow Controls

Plug-In Flow Controls

In-Line Flow Controls

Metal Flow Controls

Check Valves

Blocking Valves

Threshold Sensors

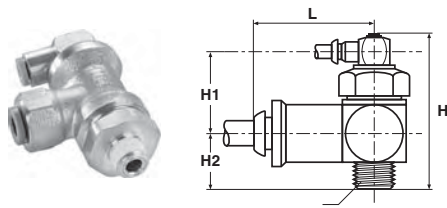

**FC601 Push-to-Connect Lock Out Valves**

Part No.	Tube Size (in)	NPT	Hex (mm)	H	H1	H2	L
FC601-4-2	1/4	1/8	21	2.03	1.24	0.79	1.10
FC601-4-4	1/4	1/4	21	2.03	1.24	0.79	1.10
FC601-6-6	3/8	3/8	24	2.19	1.14	1.04	1.38
FC601-8-8	1/2	1/2	24	2.19	1.14	1.04	1.69

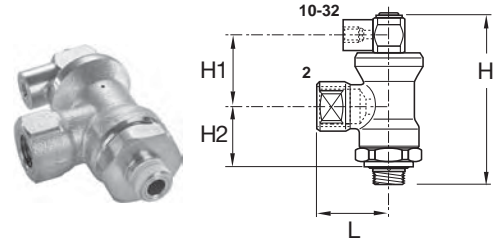

**FC602 Threaded Port Lock Out Valves**

Part No.	1 NPT	2 NPT	Hex (mm)	H	H1	H2	L
FC602-2	1/4	1/8	21	2.03	1.24	0.79	1.04
FC602-4	1/4	1/4	21	2.03	1.24	0.79	1.04
FC602-6	3/8	3/8	24	2.19	1.14	1.04	1.34
FC602-8	1/2	1/2	24	2.19	1.14	1.04	1.57

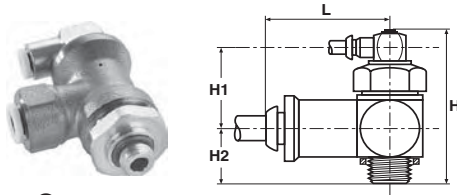

**FC601 Push-to-Connect Lock-Out Valve - BSPP**

Part No.	Tube Size (mm)	BSPP	Hex 1 (mm)	H	H1	H2	L
FC601-6M-2G	6	1/8	21	53	24.5	21.0	28.0
FC601-6M-4G	6	1/4	21	53	24.5	21.0	28.0
FC601-8M-4G	8	1/4	21	53	24.5	21.0	28.0
FC601-8M-6G	8	3/8	24	56	25.0	23.0	34.5
FC601-10M-6G	10	3/8	24	56	25.0	23.0	35.0
FC601-12M-8G	12	1/2	24	56	25.0	23.0	37.5

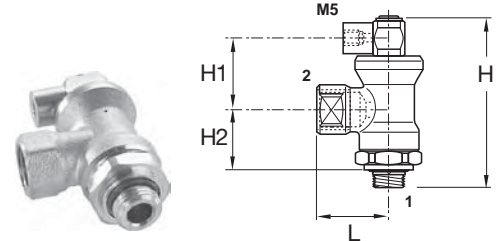

**FC608 Threaded Port Lock-Out Valve - BSPP**

Part No.	BSPP 1	BSPP 2	Hex 1 (mm)	H	H1	H2	L
FC608-4G-2G	1/8	1/4	21	53	24.5	21.0	28.0
FC608-4G-4G	1/4	1/4	21	53	24.5	21.0	28.0
FC608-6G-6G	3/8	3/8	24	56	25.0	23.0	34.0
FC608-8G-8G	1/2	1/2	24	56	25.0	23.0	41.0

**Features**

Specifications: Models PSBJ, PSPJ	
Working Temperature:	5° to 140°F
Working Pressure:	45 to 115 PSI
Breaking Pressure:	8.5 PSI
Response Time:	3 Ms

Specifications: Model PSPE	
Working Pressure:	45 to 115 PSI
Breaking Pressure:	7 PSI
Current Rating:	5A / 250VAC - 5W / 48VDC

UL Listed Component	
Reset Pressure:	10 PSI



The sensor fitting detects the absence of pressure and translates it to a high pressure pneumatic output. When used to monitor the decaying or exhausting side of a pneumatic cylinder's piston, it emits a positive output. When the cylinder comes to the end of its stroke, wherever that may be, the signal emitted from the sensor can then be used to pilot the next step.

**H**

Product Index

Compact Flow Controls

Miniature Flow Controls

Swivel Flow Controls

Plug-In Flow Controls

In-Line Flow Controls

Metal Flow Controls

Check Valves

Blocking Valves

Threshold Sensors

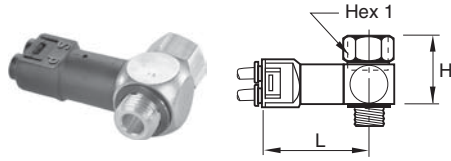

**PSBJ731 Pneumatic Threshold Sensor - 5/32 Pilot**

Part No.	NPT / UNF	Hex (mm)	H	L
PSBJ731-0	10-32	5/16	0.62	1.70
PSBJ731-2	1/8	9/16	0.90	1.74
PSBJ731-4	1/4	5/8	1.09	1.81
PSBJ731-6	3/8	7/8	1.13	1.91
PSBJ731-8	1/2	1	1.17	2.05

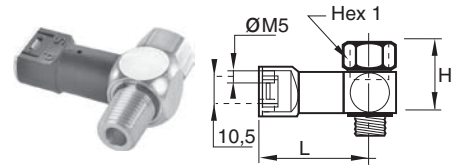

**PSBJ708 Pneumatic Threshold Sensor - M5 Pilot**

Part No.	BSPP	Hex 1 (mm)	H	L
PSBJ708-2G	1/8	14	23	40.5
PSBJ708-4G	1/4	17	28	42.5

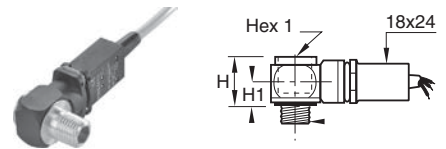

**PSPE731 Pneumatic / Electric Threshold Sensor - BSPP**

Part No.	BSPP	Hex 1 (mm)	H	H1	L
PSPE731-M5	M5X0.8	8	20	10	49
PSPE731-2G	1/8	6	20	10	52
PSPE731-4G	1/4	8	20	10	54
PSPE731-6G	3/8	10	22	12	57
PSPE731-8G	1/2	12	26	14	58

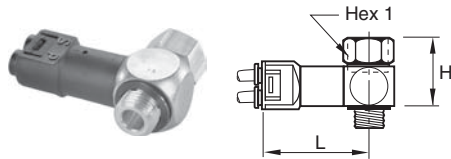

**PSBJ731 Pneumatic Threshold Sensor - 4mm Pilot**

Part No.	BSPP	Hex 1 (mm)	H	L
PSBJ731-M5	M5X0.8	8	16	43.5
PSBJ731-2G	1/8	14	23	44.5
PSBJ731-4G	1/4	17	28	46.5
PSBJ731-6G	3/8	22	29	49.0
PSBJ731-8G	1/2	27	30	52.5

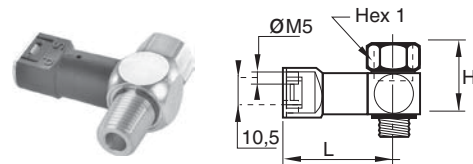

**PSPJ731 Pneumatic Threshold Sensor - 10-32 Pilot**

Part No.	NPT	Hex 1 (mm)	H	L
PSPJ731-2	1/8	9/16	0.90	1.58
PSPJ731-4	1/4	5/8	1.09	1.66
PSPJ731-6	3/8	7/8	1.13	1.76

**Notes**

---

**H**

Product  
Index

Compact  
Flow  
Controls

Miniature  
Flow  
Controls

Swivel  
Flow  
Controls

Plug-In  
Flow  
Controls

In-Line  
Flow  
Controls

Metal  
Flow  
Controls

Check  
Valves

Blocking  
Valves

Threshold  
Sensors



# Safety Guide For Selecting And Using Pneumatic Division Products And Related Accessories

## WARNING:

**FAILURE OR IMPROPER SELECTION OR IMPROPER USE OF PNEUMATIC DIVISION PRODUCTS, ASSEMBLIES OR RELATED ITEMS (“PRODUCTS”) CAN CAUSE DEATH, PERSONAL INJURY, AND PROPERTY DAMAGE. POSSIBLE CONSEQUENCES OF FAILURE OR IMPROPER SELECTION OR IMPROPER USE OF THESE PRODUCTS INCLUDE BUT ARE NOT LIMITED TO:**

- Unintended or mistimed cycling or motion of machine members or failure to cycle
- Work pieces or component parts being thrown off at high speeds.
- Failure of a device to function properly for example, failure to clamp or unclamp an associated item or device.
- Explosion
- Suddenly moving or falling objects.
- Release of toxic or otherwise injurious liquids or gasses.

Before selecting or using any of these Products, it is important that you read and follow the instructions below.

## 1. GENERAL INSTRUCTIONS

- 1.1. Scope:** This safety guide is designed to cover general guidelines on the installation, use, and maintenance of Pneumatic Division Valves, FRLs (Filters, Pressure Regulators, and Lubricators), Vacuum products and related accessory components.
- 1.2. Fail-Safe:** Valves, FRLs, Vacuum products and their related components can and do fail without warning for many reasons. Design all systems and equipment in a fail-safe mode, so that failure of associated valves, FRLs or Vacuum products will not endanger persons or property.
- 1.3. Relevant International Standards:** For a good guide to the application of a broad spectrum of pneumatic fluid power devices see: ISO 4414:1998, Pneumatic Fluid Power – General Rules Relating to Systems. See [www.iso.org](http://www.iso.org) for ordering information.
- 1.4. Distribution:** Provide a copy of this safety guide to each person that is responsible for selection, installation, or use of Valves, FRLs or Vacuum products. Do not select, or use Parker valves, FRLs or vacuum products without thoroughly reading and understanding this safety guide as well as the specific Parker publications for the products considered or selected.
- 1.5. User Responsibility:** Due to the wide variety of operating conditions and applications for valves, FRLs, and vacuum products Parker and its distributors do not represent or warrant that any particular valve, FRL or vacuum product is suitable for any specific end use system. This safety guide does not analyze all technical parameters that must be considered in selecting a product. The user, through its own analysis and testing, is solely responsible for:
  - Making the final selection of the appropriate valve, FRL, Vacuum component, or accessory.
  - Assuring that all user's performance, endurance, maintenance, safety, and warning requirements are met and that the application presents no health or safety hazards.
  - Complying with all existing warning labels and / or providing all appropriate health and safety warnings on the equipment on which the valves, FRLs or Vacuum products are used; and,
  - Assuring compliance with all applicable government and industry standards.
- 1.6. Safety Devices:** Safety devices should not be removed, or defeated.
- 1.7. Warning Labels:** Warning labels should not be removed, painted over or otherwise obscured.
- 1.8. Additional Questions:** Call the appropriate Parker technical service department if you have any questions or require any additional information. See the Parker publication for the product being considered or used, or call 1-800-CPARKER, or go to [www.parker.com](http://www.parker.com), for telephone numbers of the appropriate technical service department.

## 2. PRODUCT SELECTION INSTRUCTIONS

- 2.1. Flow Rate:** The flow rate requirements of a system are frequently the primary consideration when designing any pneumatic system. System components need to be able to provide adequate flow and pressure for the desired application.
- 2.2. Pressure Rating:** Never exceed the rated pressure of a product. Consult product labeling, Pneumatic Division catalogs or the instruction sheets supplied for maximum pressure ratings.
- 2.3. Temperature Rating:** Never exceed the temperature rating of a product. Excessive heat can shorten the life expectancy of a product and result in complete product failure.
- 2.4. Environment:** Many environmental conditions can affect the integrity and suitability of a product for a given application. Pneumatic Division products are designed for use in general purpose industrial applications. If these products are to be used in unusual circumstances such as direct sunlight and/or corrosive or caustic environments, such use can shorten the useful life and lead to premature failure of a product.
- 2.5. Lubrication and Compressor Carryover:** Some modern synthetic oils can and will attack nitrile seals. If there is any possibility of synthetic oils or greases migrating into the pneumatic components check for compatibility with the seal materials used. Consult the factory or product literature for materials of construction.
- 2.6. Polycarbonate Bowls and Sight Glasses:** To avoid potential polycarbonate bowl failures:
  - Do not locate polycarbonate bowls or sight glasses in areas where they could be subject to direct sunlight, impact blow, or temperatures outside of the rated range.
  - Do not expose or clean polycarbonate bowls with detergents, chlorinated hydro-carbons, ketones, esters or certain alcohols.
  - Do not use polycarbonate bowls or sight glasses in air systems where compressors are lubricated with fire resistant fluids such as phosphate ester and di-ester lubricants.

## Safety Guide

**2.7. Chemical Compatibility:** For more information on plastic component chemical compatibility see Pneumatic Division technical bulletins Tec-3, Tec-4, and Tec-5

- 2.8. Product Rupture:** Product rupture can cause death, serious personal injury, and property damage.
- Do not connect pressure regulators or other Pneumatic Division products to bottled gas cylinders.
  - Do not exceed the maximum primary pressure rating of any pressure regulator or any system component.
  - Consult product labeling or product literature for pressure rating limitations.

### 3. PRODUCT ASSEMBLY AND INSTALLATION INSTRUCTIONS

**3.1. Component Inspection:** Prior to assembly or installation a careful examination of the valves, FRLs or vacuum products must be performed. All components must be checked for correct style, size, and catalog number. DO NOT use any component that displays any signs of nonconformance.

**3.2. Installation Instructions:** Parker published Installation Instructions must be followed for installation of Parker valves, FRLs and vacuum components. These instructions are provided with every Parker valve or FRL sold, or by calling 1-800-CPARKER, or at [www.parker.com](http://www.parker.com).

**3.3. Air Supply:** The air supply or control medium supplied to Valves, FRLs and Vacuum components must be moisture-free if ambient temperature can drop below freezing

### 4. VALVE AND FRL MAINTENANCE AND REPLACEMENT INSTRUCTIONS

**4.1. Maintenance:** Even with proper selection and installation, valve, FRL and vacuum products service life may be significantly reduced without a continuing maintenance program. The severity of the application, risk potential from a component failure, and experience with any known failures in the application or in similar applications should determine the frequency of inspections and the servicing or replacement of Pneumatic Division products so that products are replaced before any failure occurs. A maintenance program must be established and followed by the user and, at minimum, must include instructions 4.2 through 4.10.

**4.2. Installation and Service Instructions:** Before attempting to service or replace any worn or damaged parts consult the appropriate Service Bulletin for the valve or FRL in question for the appropriate practices to service the unit in question. These Service and Installation Instructions are provided with every Parker valve and FRL sold, or are available by calling 1-800-CPARKER, or by accessing the Parker web site at [www.parker.com](http://www.parker.com).

**4.3. Lockout / Tagout Procedures:** Be sure to follow all required lockout and tagout procedures when servicing equipment. For more information see: OSHA Standard – 29 CFR, Part 1910.147, Appendix A, The Control of Hazardous Energy – (Lockout / Tagout)

**4.4. Visual Inspection:** Any of the following conditions requires immediate system shut down and replacement of worn or damaged components:

- Air leakage: Look and listen to see if there are any signs of visual damage to any of the components in the system. Leakage is an indication of worn or damaged components.
- Damaged or degraded components: Look to see if there are any visible signs of wear or component degradation.
- Kinked, crushed, or damaged hoses. Kinked hoses can result in restricted air flow and lead to unpredictable system behavior.
- Any observed improper system or component function: Immediately shut down the system and correct malfunction.
- Excessive dirt build-up: Dirt and clutter can mask potentially hazardous situations.

**Caution: Leak detection solutions should be rinsed off after use.**

**4.5. Routine Maintenance Issues:**

- Remove excessive dirt, grime and clutter from work areas.
- Make sure all required guards and shields are in place.

**4.6. Functional Test:** Before initiating automatic operation, operate the system manually to make sure all required functions operate properly and safely.

**4.7. Service or Replacement Intervals:** It is the user's responsibility to establish appropriate service intervals. Valves, FRLs and vacuum products contain components that age, harden, wear, and otherwise deteriorate over time. Environmental conditions can significantly accelerate this process. Valves, FRLs and vacuum components need to be serviced or replaced on routine intervals. Service intervals need to be established based on:

- Previous performance experiences.
- Government and / or industrial standards.
- When failures could result in unacceptable down time, equipment damage or personal injury risk.

**4.8. Servicing or Replacing of any Worn or Damaged Parts:** To avoid unpredictable system behavior that can cause death, personal injury and property damage:

- Follow all government, state and local safety and servicing practices prior to service including but not limited to all OSHA Lockout Tagout procedures (OSHA Standard – 29 CFR, Part 1910.147, Appendix A, The Control of Hazardous Energy – Lockout / Tagout).
- Disconnect electrical supply (when necessary) before installation, servicing, or conversion.
- Disconnect air supply and depressurize all air lines connected to system and Pneumatic Division products before installation, service, or conversion.
- Installation, servicing, and / or conversion of these products must be performed by knowledgeable personnel who understand how pneumatic products are to be applied.
- After installation, servicing, or conversions air and electrical supplies (when necessary) should be connected and the product tested for proper function and leakage. If audible leakage is present, or if the product does not operate properly, do not put product or system into use.
- Warnings and specifications on the product should not be covered or painted over. If masking is not possible, contact your local representative for replacement labels.

**4.9. Putting Serviced System Back into Operation:** Follow the guidelines above and all relevant Installation and Maintenance Instructions supplied with the valve FRL or vacuum component to insure proper function of the system.

The items described in this document and other documents and descriptions provided by Parker Hannifin Corporation, its subsidiaries and its authorized distributors ("Seller") are hereby offered for sale at prices to be established by Seller. This offer and its acceptance by any customer ("Buyer") shall be governed by all of the following Terms and Conditions. Buyer's order for any item described in its document, when communicated to Seller verbally, or in writing, shall constitute acceptance of this offer. All goods or work described will be referred to as "Products".

- 1. Terms and Conditions.** Seller's willingness to offer Products, or accept an order for Products, to or from Buyer is subject to these Terms and Conditions or any newer version of the terms and conditions found on-line at [www.parker.com/saleterms/](http://www.parker.com/saleterms/). Seller objects to any contrary or additional terms or conditions of Buyer's order or any other document issued by Buyer.
- 2. Price Adjustments; Payments.** Prices stated on Seller's quote or other documentation offered by Seller are valid for 30 days, and do not include any sales, use, or other taxes unless specifically stated. Unless otherwise specified by Seller, all prices are F.C.A. Seller's facility (INCOTERMS 2010). Payment is subject to credit approval and is due 30 days from the date of invoice or such other term as required by Seller's Credit Department, after which Buyer shall pay interest on any unpaid invoices at the rate of 1.5% per month or the maximum allowable rate under applicable law.
- 3. Delivery Dates; Title and Risk; Shipment.** All delivery dates are approximate and Seller shall not be responsible for any damages resulting from any delay. Regardless of the manner of shipment, title to any products and risk of loss or damage shall pass to Buyer upon placement of the products with the shipment carrier at Seller's facility. Unless otherwise stated, Seller may exercise its judgment in choosing the carrier and means of delivery. No deferral of shipment at Buyers' request beyond the respective dates indicated will be made except on terms that will indemnify, defend and hold Seller harmless against all loss and additional expense. Buyer shall be responsible for any additional shipping charges incurred by Seller due to Buyer's acts or omissions.
- 4. Warranty.** Seller warrants that the Products sold hereunder shall be free from defects in material or workmanship for a period of twelve months from the date of delivery to Buyer or 2,000 hours of normal use, whichever occurs first. The prices charged for Seller's products are based upon the exclusive limited warranty stated above, and upon the following disclaimer: **DISCLAIMER OF WARRANTY: THIS WARRANTY COMPRISES THE SOLE AND ENTIRE WARRANTY PERTAINING TO PRODUCTS PROVIDED HEREUNDER. SELLER DISCLAIMS ALL OTHER WARRANTIES, EXPRESS AND IMPLIED, INCLUDING DESIGN, MERCHANTABILITY AND FITNESS FOR A PARTICULAR PURPOSE.**
- 5. Claims; Commencement of Actions.** Buyer shall promptly inspect all Products upon delivery. No claims for shortages will be allowed unless reported to the Seller within 10 days of delivery. No other claims against Seller will be allowed unless asserted in writing within 30 days after delivery. Buyer shall notify Seller of any alleged breach of warranty within 30 days after the date the defect is or should have been discovered by Buyer. Any action based upon breach of this agreement or upon any other claim arising out of this sale (other than an action by Seller for an amount due on any invoice) must be commenced within 12 months from the date of the breach without regard to the date breach is discovered.
- 6. LIMITATION OF LIABILITY.** UPON NOTIFICATION, SELLER WILL, AT ITS OPTION, REPAIR OR REPLACE A DEFECTIVE PRODUCT, OR REFUND THE PURCHASE PRICE. IN NO EVENT SHALL SELLER BE LIABLE TO BUYER FOR ANY SPECIAL, INDIRECT, INCIDENTAL OR CONSEQUENTIAL DAMAGES ARISING OUT OF, OR AS THE RESULT OF, THE SALE, DELIVERY, NON-DELIVERY, SERVICING, USE OR LOSS OF USE OF THE PRODUCTS OR ANY PART THEREOF, OR FOR ANY CHARGES OR EXPENSES OF ANY NATURE INCURRED WITHOUT SELLER'S WRITTEN CONSENT, EVEN IF SELLER HAS BEEN NEGLIGENT, WHETHER IN CONTRACT, TORT OR OTHER LEGAL THEORY. IN NO EVENT SHALL SELLER'S LIABILITY UNDER ANY CLAIM MADE BY BUYER EXCEED THE PURCHASE PRICE OF THE PRODUCTS.
- 7. User Responsibility.** The user, through its own analysis and testing, is solely responsible for making the final selection of the system and Product and assuring that all performance, endurance, maintenance, safety and warning requirements of the application are met. The user must analyze all aspects of the application and follow applicable industry standards and Product information. If Seller provides Product or system options, the user is responsible for determining that such data and specifications are suitable and sufficient for all applications and reasonably foreseeable uses of the Products or systems.
- 8. Loss to Buyer's Property.** Any designs, tools, patterns, materials, drawings, confidential information or equipment furnished by Buyer or any other items which become Buyer's property, may be considered obsolete and may be destroyed by Seller after two consecutive years have elapsed without Buyer ordering the items manufactured using such property. Seller shall not be responsible for any loss or damage to such property while it is in Seller's possession or control.
- 9. Special Tooling.** A tooling charge may be imposed for any special tooling, including without limitation, dies, fixtures, molds and patterns, acquired to manufacture Products. Such special tooling shall be and remain Seller's property notwithstanding payment of any charges by Buyer. In no event will Buyer acquire any interest in apparatus belonging to Seller which is utilized in the manufacture of the Products, even if such apparatus has been specially converted or adapted for such manufacture and notwithstanding any charges paid by Buyer. Unless otherwise agreed, Seller shall have the right to alter, discard or otherwise dispose of any special tooling or other property in its sole discretion at any time.
- 10. Buyer's Obligation; Rights of Seller.** To secure payment of all sums due or otherwise, Seller shall retain a security interest in the goods delivered and this agreement shall be deemed a Security Agreement under the Uniform Commercial Code. Buyer authorizes Seller as its attorney to execute and file on Buyer's behalf all documents Seller deems necessary to perfect its security interest.
- 11. Improper use and Indemnity.** Buyer shall indemnify, defend, and hold Seller harmless from any claim, liability, damages, lawsuits, and costs (including attorney fees), whether for personal injury, property damage, patent, trademark or copyright

infringement or any other claim, brought by or incurred by Buyer, Buyer's employees, or any other person, arising out of: (a) improper selection, improper application or other misuse of Products purchased by Buyer from Seller; (b) any act or omission, negligent or otherwise, of Buyer; (c) Seller's use of patterns, plans, drawings, or specifications furnished by Buyer to manufacture Product; or (d) Buyer's failure to comply with these terms and conditions. Seller shall not indemnify Buyer under any circumstance except as otherwise provided.

- 12. Cancellations and Changes.** Orders shall not be subject to cancellation or change by Buyer for any reason, except with Seller's written consent and upon terms that will indemnify, defend and hold Seller harmless against all direct, incidental and consequential loss or damage. Seller may change product features, specifications, designs and availability with notice to Buyer.
- 13. Limitation on Assignment.** Buyer may not assign its rights or obligations under this agreement without the prior written consent of Seller.
- 14. Force Majeure.** Seller does not assume the risk and shall not be liable for delay or failure to perform any of Seller's obligations by reason of circumstances beyond the reasonable control of Seller (hereinafter "Events of Force Majeure") Events of Force Majeure shall include without limitation: accidents, strikes or labor disputes, acts of any government or government agency, acts of nature, delays or failures in delivery from carriers or suppliers, shortages of materials, or any other cause beyond Seller's reasonable control.
- 15. Waiver and Severability.** Failure to enforce any provision of this agreement will not waive that provision nor will any such failure prejudice Seller's right to enforce that provision in the future. Invalidation of any provision of this agreement by legislation or other rule of law shall not invalidate any other provision herein. The remaining provisions of this agreement will remain in full force and effect.
- 16. Termination.** Seller may terminate this agreement for any reason and at any time by giving Buyer thirty (30) days written notice of termination. Seller may immediately terminate this agreement, in writing, if Buyer: (a) commits a breach of any provision of this agreement (b) appoints a trustee, receiver or custodian for all or any part of Buyer's property (c) files a petition for relief in bankruptcy on its own behalf, or by a third party (d) makes an assignment for the benefit of creditors, or (e) the dissolves or liquidates all or a majority of its assets.
- 17. Governing Law.** This agreement and the sale and delivery of all Products hereunder shall be deemed to have taken place in and shall be governed and construed in accordance with the laws of the State of Ohio, as applicable to contracts executed and wholly performed therein and without regard to conflicts of laws principles. Buyer irrevocably agrees and consents to the exclusive jurisdiction and venue of the courts of Cuyahoga County, Ohio with respect to any dispute, controversy or claim arising out of or relating to this agreement.
- 18. Indemnity for Infringement of Intellectual Property Rights.** Seller shall have no liability for infringement of any patents, trademarks, copyrights, trade dress, trade secrets or similar rights except as provided in this Section. Seller will defend and indemnify Buyer against allegations of infringement of U.S. patents, U.S. trademarks, copyrights, trade dress and trade secrets ("Intellectual Property Rights"). Seller will defend at its expense and will pay the cost of any settlement or damages awarded in an action brought against Buyer based on an allegation that a Product sold pursuant to this Agreement infringes the Intellectual Property Rights of a third party. Seller's obligation to defend and indemnify Buyer is contingent on Buyer notifying Seller within ten (10) days after Buyer becomes aware of such allegations of infringement, and Seller having sole control over the defense of any allegations or actions including all negotiations for settlement or compromise. If a Product is subject to a claim that it infringes the Intellectual Property Rights of a third party, Seller may, at its sole expense and option, procure for Buyer the right to continue using the Product, replace or modify the Product so as to make it noninfringing, or offer to accept return of the Product and return the purchase price less a reasonable allowance for depreciation. Notwithstanding the foregoing, Seller shall have no liability for claims of infringement based on information provided by Buyer, or directed to Products delivered hereunder for which the designs are specified in whole or part by Buyer, or infringements resulting from the modification, combination or use in a system of any Product sold hereunder. The foregoing provisions of this Section shall constitute Seller's sole and exclusive liability and Buyer's sole and exclusive remedy for infringement of Intellectual Property Rights.
- 19. Entire Agreement.** This agreement contains the entire agreement between the Buyer and Seller and constitutes the final, complete and exclusive expression of the terms of sale. All prior or contemporaneous written or oral agreements or negotiations with respect to the subject matter are herein merged.
- 20. Compliance with Law, U. K. Bribery Act and U.S. Foreign Corrupt Practices Act.** Buyer agrees to comply with all applicable laws and regulations, including both those of the United Kingdom and the United States of America, and of the country or countries of the Territory in which the Buyer may operate, including without limitation the U. K. Bribery Act, the U.S. Foreign Corrupt Practices Act ("FCPA") and the U.S. Anti-Kickback Act (the "Anti-Kickback Act"), and agrees to indemnify and hold harmless Seller from the consequences of any violation of such provisions by Buyer, its employees or agents. Buyer acknowledges that they are familiar with the provisions of the U. K. Bribery Act, the FCPA and the Anti-Kickback Act, and certifies that Buyer will adhere to the requirements thereof. In particular, Buyer represents and agrees that Buyer shall not make any payment or give anything of value, directly or indirectly to any governmental official, any foreign political party or official thereof, any candidate for foreign political office, or any commercial entity or person, for the purpose of influencing such person to purchase products or otherwise benefit the business of Seller.

02/12