



OPTIVIEW™ CONTROL CENTER NON-YORK CENTRIFUGAL LIQUID CHILLERS

INSTALLATION MANUAL

Supersedes: 160.10-N1 (310)

Form 160.10-N1 (615)

OPTIVIEW™ CONTROL CENTER RETROFIT KIT FOR TRANE LOW PRESSURE CENTRIFUGAL CHILLERS

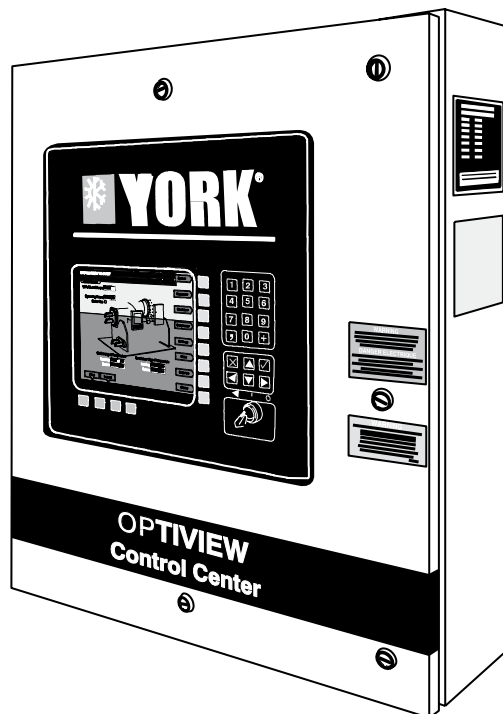

LD10282

Issue Date:
June 23, 2015



IMPORTANT!

READ BEFORE PROCEEDING!

GENERAL SAFETY GUIDELINES

This equipment is a relatively complicated apparatus. During rigging, installation, operation, maintenance, or service, individuals may be exposed to certain components or conditions including, but not limited to: heavy objects, refrigerants, materials under pressure, rotating components, and both high and low voltage. Each of these items has the potential, if misused or handled improperly, to cause bodily injury or death. It is the obligation and responsibility of rigging, installation, and operating/service personnel to identify and recognize these inherent hazards, protect themselves, and proceed safely in completing their tasks. Failure to comply with any of these requirements could result in serious damage to the equipment and the property in

which it is situated, as well as severe personal injury or death to themselves and people at the site.

This document is intended for use by owner-authorized rigging, installation, and operating/service personnel. It is expected that these individuals possess independent training that will enable them to perform their assigned tasks properly and safely. It is essential that, prior to performing any task on this equipment, this individual shall have read and understood the on-product labels, this document and any referenced materials. This individual shall also be familiar with and comply with all applicable industry and governmental standards and regulations pertaining to the task in question.

SAFETY SYMBOLS

The following symbols are used in this document to alert the reader to specific situations:



Indicates a possible hazardous situation which will result in death or serious injury if proper care is not taken.



Identifies a hazard which could lead to damage to the machine, damage to other equipment and/or environmental pollution if proper care is not taken or instructions and are not followed.



Indicates a potentially hazardous situation which will result in possible injuries or damage to equipment if proper care is not taken.

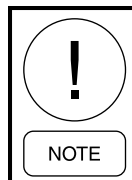

Highlights additional information useful to the technician in completing the work being performed properly.



External wiring, unless specified as an optional connection in the manufacturer's product line, is not to be connected inside the control cabinet. Devices such as relays, switches, transducers and controls and any external wiring must not be installed inside the micro panel. All wiring must be in accordance with Johnson Controls' published specifications and must be performed only by a qualified electrician. Johnson Controls will NOT be responsible for damage/problems resulting from improper connections to the controls or application of improper control signals. Failure to follow this warning will void the manufacturer's warranty and cause serious damage to property or personal injury.

CHANGEABILITY OF THIS DOCUMENT

In complying with Johnson Controls' policy for continuous product improvement, the information contained in this document is subject to change without notice. Johnson Controls makes no commitment to update or provide current information automatically to the manual or product owner. Updated manuals, if applicable, can be obtained by contacting the nearest Johnson Controls Service office or accessing the Johnson Controls QuickLIT website at <http://cgproducts.johnsoncontrols.com>.

It is the responsibility of rigging, lifting, and operating/service personnel to verify the applicability of these documents to the equipment. If there is any question

regarding the applicability of these documents, rigging, lifting, and operating/service personnel should verify whether the equipment has been modified and if current literature is available from the owner of the equipment prior to performing any work on the chiller.

CHANGE BARS

Revisions made to this document are indicated with a line along the left or right hand column in the area the revision was made. These revisions are to technical information and any other changes in spelling, grammar or formatting are not included.

ASSOCIATED LITERATURE

MANUAL DESCRIPTION	FORM NUMBER
OptiView Control Center Retrofit Kit - Trane Installation Manual	160.10-N1
OptiView Control Center Retrofit Kit - Trane Operation Manual	160.10-O1
Wiring Diagram – Unit with Electromechanical Starter	160.10-PW1
Renewal Parts – OptiView Control Center Retrofit Kit	160.10-RP1
Solid State Starter MOD "B" – Operation/Service Manual	160.00-O2
Variable Speed Drive – Operation Manual	160.00-O1

THIS PAGE INTENTIONALLY LEFT BLANK.

TABLE OF CONTENTS

SECTION 1 - OPTIVIEW RETROFIT KIT INTRODUCTION	11
Retrofit Kit Description.....	11
Retrofit Kit Options	12
Additional Items	13
Bill Of Materials	15
Optiview Retrofit Kit Part Identification	17
SECTION 2 - OPTIVIEW RETROFIT KIT INSTALLATION	19
Prior to beginning	19
Site Preparation And Disassembly	19
OptiView Retrofit Kit Installation	20
OptiView Panel/Junction Box Mounting	20
Chiller Purge Unit	22
Trane Purge Unit.....	22
SkyGuard II Purge Unit.....	23
TurboGuard II Purge Unit.....	23
Purge Canister	23
Retrofit Kit Sensors	24
Refrigerant Sensors (Optional Kit).....	29
Retrofit Kit Wiring	30
Printer	34
Current Transformers / Current Module	34
General.....	37
Software Settings	38
Installation	39
Required Parts	39
SECTION 3 - WYE-DELTA ELECTROMECHANICAL STARTER.....	41
Wye-Delta Starter Wiring.....	41
Wye-Delta Starter Wiring.....	43
SECTION 4 - ACROSS-THE-LINE STARTER.....	45
Across-The-Line Starter Wiring	45
SECTION 5 - OPTIVIEW RETROFIT KIT COMMISSIONING	47
Description	47
031-2430 Microboard	47
Input/Output Boards	48
OptiView Software.....	48
Evaporator Screen	49
Load Rate Screen	49
Condenser Screen/Purge.....	49
Compressor Screen	49
Oil Sump Screen	49
Motor Screen.....	49
Motor Temperature Screen.....	49
Setpoints Screen	50
Setup Screen.....	50
User Screen	50

TABLE OF CONTENTS (CONT'D)

Operations Screen	50
Schedule Screen	50
Comms Screen.....	50
Printer Screen	50
Sales Order Screen.....	50
History Screen.....	50
Starter/Motor Testing	51
Wye-Delta Electromechanical Starter	51
Autotransformer Electromechanical Starter	51
Across-The-Line Electromechanical Starter.....	52
Motor rotation test	53
Current Module (CM-2) Calibration	53
SECTION 6 - LIQUID BY-PASS.....	55
Liquid By-Pass Operation.....	55
Screen Display Values	55
Operation.....	55
Installation	55
Wiring	56
SECTION 7 - MOTOR COOLING	57
Motor Cooling	57
Screen Display Values	57
Operation.....	57
Installation	57
Wiring	57
APPENDIX A - ANALOG MOTOR WINDING SENSOR DATA	59
APPENDIX B - ANALOG SENSOR INPUT RANGES	61
APPENDIX C - PROGRAMMABLE SETPOINT VALUES	63
APPENDIX D - KIT INSTALLATION CHECKLIST	69
Temperature	72

LIST OF FIGURES

FIGURE 1 - Optiview Control Center.....	11
FIGURE 2 - Adjustable Mounting Assembly.....	12
FIGURE 3 - Refrigerant Temp. Sensor Kit.....	12
FIGURE 4 - Vane Control Motor.....	13
FIGURE 5 - OptiView Control Center.....	17
FIGURE 6 - HP Cutout Switch, RTD Module, 3R Relay, Relay Socket.....	17
FIGURE 7 - Sensor Wiring Harness, Connectors, Terminals, Applicator Crimp Tool.....	17
FIGURE 8 - Auxiliary and Junction Boxes.....	17
FIGURE 9 - E-M Wiring Harness, Ribbon Cable, Varistors, Surge Suppressor.....	17
FIGURE 10 - Pressure Transducers.....	17
FIGURE 11 - Thermowell, Temperature Sensors.....	18
FIGURE 12 - Current Module (CM-2), Diode Rectifier, Slide Resistor Assembly.....	18
FIGURE 13 - PRV Solid State Relays, Resistors, CR1 Starter Control Relay.....	18
FIGURE 14 - Low Oil Pressure Cutout Switch.....	18
FIGURE 15 - Trane Chiller.....	19
FIGURE 16 - OptiView Panel Mounting.....	20
FIGURE 17 - Mounting Assembly Hardware.....	20
FIGURE 18 - Trane Purge Human Interface.....	21
FIGURE 19 - Auxiliary Box Components.....	21
FIGURE 20 - RTD Conditioner Dip Switch.....	21
FIGURE 21 - Oil pressure safety switch.....	22
FIGURE 22 - PRV Solid State Relays.....	22
FIGURE 23 - Trane Human Interface.....	22
FIGURE 24 - Trane Purge Unit.....	23
FIGURE 25 - Typical CVHE, CVHF Sensor/Solenoid Locations.....	24
FIGURE 26 - Typical CVHB Sensor Locations.....	25
FIGURE 27 - Oil Temperature Sensor.....	26
FIGURE 28 - Condenser Water Sensors.....	26
FIGURE 29 - Chilled Liquid Sensors.....	26
FIGURE 30 - Oil Pressure Transducers.....	27
FIGURE 31 - Oil Pressure Safety Switch.....	27
FIGURE 32 - Condenser Pressure Transducer.....	27
FIGURE 33 - Evaporator Pressure Transducer.....	28
FIGURE 34 - Discharge Temperature Sensor.....	28
FIGURE 35 - Outboard Bearing Sensor.....	28
FIGURE 36 - Inboard Bearing Sensor.....	29
FIGURE 37 - Condenser Temperature Sensor.....	29
FIGURE 38 - Evaporator Temperature Sensor.....	29
FIGURE 39 - Drop Leg Temperature Sensor.....	29
FIGURE 40 - Harness Microboard Connections.....	30
FIGURE 41 - Harness Terminal Connections.....	30
FIGURE 42 - Sensor Cable Strap Details.....	30
FIGURE 43 - Winding Temperature RTD Box.....	31
FIGURE 44 - Motor RTD Signal Conditioners.....	31
FIGURE 45 - Motor RTD Cable Routing.....	32
FIGURE 46 - Vent Line Solenoid.....	32
FIGURE 47 - PRV Motor.....	32
FIGURE 48 - Oil Sump.....	32
FIGURE 49 - Auxiliary Junction Box Components.....	33
FIGURE 50 - Input/Output Board.....	33
FIGURE 51 - PRV Solid State Relays.....	33
FIGURE 52 - Input/Output Board.....	34
FIGURE 53 - Current Module (CM-2) Board.....	35
FIGURE 54 - I/O Board and TB6.....	35
FIGURE 55 - Current Transformers.....	35

LIST OF FIGURES (CONT'D)

FIGURE 56 - Current Module (CM-2) Board	36
FIGURE 57 - PRV Solid State Relays	37
FIGURE 58 - OPTIVIEW Retrofits	37
FIGURE 59 - Correct Placement of Limit Switches	37
FIGURE 60 - Incorrect Placement of Limit Switches	37
FIGURE 61 - Trane Actuator Wiring Schematic	38
FIGURE 62 - Trane CVHE_CVHF K Design	42
FIGURE 63 - Trane CVHE_CVHF X Design	44
FIGURE 64 - ATL Starter Wiring	45
FIGURE 65 - OptiView 2430 Microboard	48
FIGURE 66 - Wye-Delta Starter Example	51
FIGURE 67 - ATL Starter Example	52
FIGURE 68 - Momentary Jog Switch	53
FIGURE 69 - Clamp-on Ammeter	54
FIGURE 70 - Current Module (CM-2) Board	54
FIGURE 71 - Liquid/Orifice Bypass Example	56
FIGURE 72 - Liquid/Orifice Bypass Example	56
FIGURE 73 - Refrigerant Pump	57

LIST OF TABLES

TABLE 1 - Current Transformer Kits	12
TABLE 2 - Phase Monitor Models	13
TABLE 3 - Bill of Materials	15
TABLE 4 - Typical CVHE, CVHF Sensor/Solenoid Locations	24
TABLE 5 - Typical CVHB Sensor Locations	25
TABLE 6 - Printer Microboard Connections	34
TABLE 7 - CT Installation Table	35
TABLE 8 - Slide Resistor Calculation	36
TABLE 9 - Analog Motor Winding/Bearing Sensor Data	59
TABLE 10 - Analog Sensor Input Ranges	61
TABLE 11 - Programmable setpoint values	63
TABLE 12 - SI Metric Conversion	72

EMERGENCY SHUTDOWN

In case an emergency of any type should arise while the chiller is running, IMMEDIATELY switch the OptiView compressor switch to the OFF position.

RESPONSIBILITY FOR SAFETY

Every effort has been made in the design and manufacture of this kit to ensure the safety of personnel working on the chiller. However, the individual operating/working on any equipment is ultimately responsible for:

- Personal safety, the safety of other personnel, and the machinery
- Correct utilization of the machinery in accordance with the procedures detailed in the YORK and Trane manuals
- Proper chiller maintenance

ABOUT THIS MANUAL

The contents of this manual include suggested best working practices and procedures related to the installation of this kit. These instructions are issued for guidance only; they do not take precedence over the above stated individual responsibility and local safety regulations.

The instructions included with this kit have been written for professional and qualified service technicians only. This manual is meant as a recommended guide to install the kit components for the most favorable operation. YORK will not be responsible for damage caused by improper installation, maintenance or operation.

For information related directly to the chiller shells, compressor and other components, refer to the specific manual provided by the manufacturer of the chiller.

PROPER EQUIPMENT HANDLING

Proper Lock-Out / Tag-Out

To ensure safety, notify proper personnel of chiller shutdown and then proceed to switch off the chiller and lock-out / isolate all chiller power supply. Be sure to tag the chiller as “Out of Operation”. Keep the lock-out key on person to avoid accidental chiller restart.

Suitability for Application

The OptiView Retrofit Kit is intended to control and operate competitive centrifugal chillers cooling water or brine solutions and is not suitable for purposes other than those specified in these instructions. Any use of the equipment other than what is intended or operation of the equipment contrary to the relevant procedures may result in injury to the operator, or damage to the equipment. Johnson Controls will NOT be responsible for damage due to misuse.

The chiller must not be operated outside the design parameters specified in any of the manuals included with the OptiView Retrofit Kit and the Trane unit.

Structural Support

Proper structural support of the OptiView Panel must be provided as indicated in these instructions. Failure to provide proper support may result in injury to the operator or damage to the equipment and/or building.

Mechanical Strength

The OptiView Panel is not designed to withstand loads or stresses from adjacent equipment, pipework or structures. No other components may be mounted on or to the OptiView Control Panel. Any extraneous loads may cause failure and may result in injury to the operator, or damage to the equipment.

Pressure Systems

The chiller contains refrigerant vapor and liquid under pressure, which can be a hazardous and cause injury if released. Care must be taken during installation, operation and maintenance of this kit to avoid damage to the pressure system. No attempt should be made to gain access to the component parts of the pressure system other than by suitably trained and qualified personnel.

Electrical

The control center must be grounded. No installation or maintenance work should be attempted on the electrical equipment without first switching the equipment OFF, then isolating and locking out the power supply. Work on live equipment must only be carried out by suitably trained and qualified personnel. Do not attempt to gain access to the inside of the control panel or electrical enclosures during normal operation of the unit.

Refrigerants and Oils

Refrigerants and oils used in the unit are generally non-toxic, non-flammable and non-corrosive, and pose no special safety hazards. However, when an open flame is applied to refrigerant, toxic gases are created. Never subject refrigerant to an open flame. The possibility of refrigerant vapor build up does pose a risk of asphyxiation in confined or enclosed spaces and attention should be given to provide good ventilation.

Use of gloves and safety glasses are required when working with refrigerant and oil.

General Access

There are a number of areas and features which may be a hazard and potentially cause injury when operating the Control Center and chiller unless suitable safety precautions are taken. Access to the Control Center and chiller should be restricted to suitably qualified persons who are familiar with the potential hazards and precautions necessary for safe operation and maintenance of equipment containing high temperatures, pressures and voltages.

SECTION 1 - OPTIVIEW RETROFIT KIT INTRODUCTION

RETROFIT KIT DESCRIPTION

The OptiView Control Center Retrofit Kit for Trane low-pressure centrifugal chillers is a state of the art microprocessor-based control system that monitors and controls operation of competitive Non-York chillers. This kit is designed for use with Trane CVHA, CVHB, CVHE, and CVHF model chillers.

This basic kit (375-47045-XXX) provides the necessary and major components in order to retrofit the OptiView Control Center to a Trane chiller with an electromechanical starter. The main components of this kit consist of the OptiView Control Center, the OptiView operating software specific to Trane chillers, the CM-2 current module, all necessary pressure transducers and thermistors, and all manuals related to the installation, operation and service of this kit.

A current transformer kit to monitor compressor motor operations is provided and must be selected based upon starter configuration. Refer to *Table 1* for selection criteria.

This kit is comprehensive, but due to differences in chiller setups, not all components are provided. The technician installing the OptiView Control Center Retrofit Kit must field-source some components or create them by light fabrication. A list of possible items required to complete kit installation is shown in the *Additional Items* portion of this section.

There are several hardware options for the technician to decide upon during installation. These optional items are listed in the *Retrofit Kit Options* portion of this section. Please note that not all components included with this kit will be used during installation!

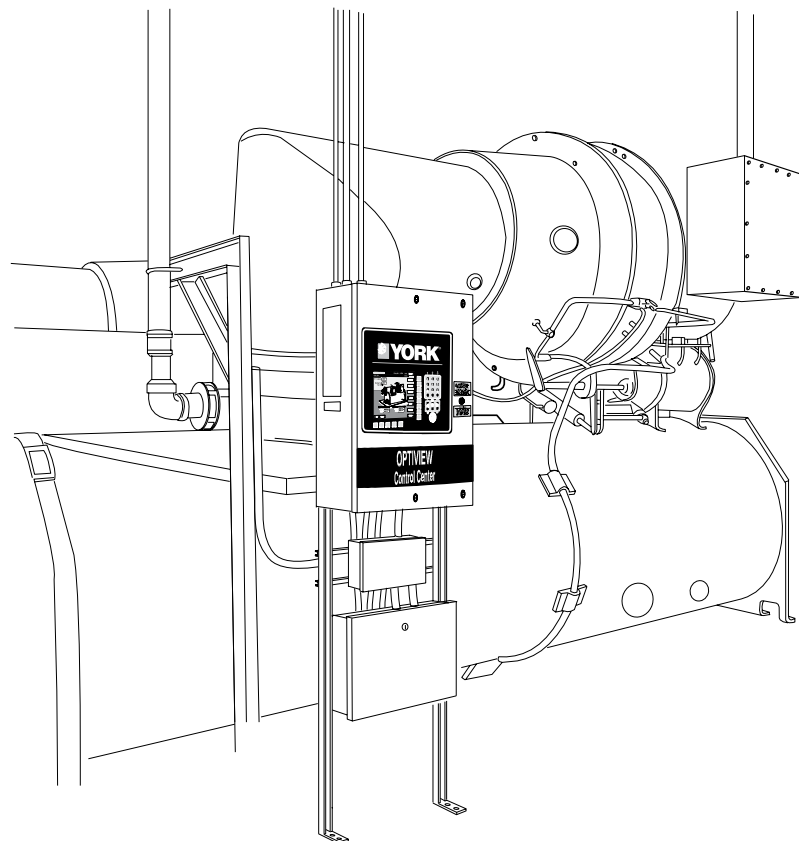

LD10254

FIGURE 1 - OPTIVIEW CONTROL CENTER

The OptiView Control Center Retrofit Kit is designed to be a complete control system for the competitive Trane chiller, however, some parts may be reused during the installation of the OptiView kit. Therefore, all parts removed from the chiller should be retained for possible reuse. Any parts required for reuse should be inspected and replaced if in questionable condition.

Field electrical wiring is required to install this kit and must be performed by a competent, qualified technician or electrician to national and local code. Before beginning installation, verify that the wiring diagrams included with the Trane chiller are comparable with the YORK-supplied diagrams for compatibility purposes.

Retrofit Kit Options

There are several component options that must be decided upon when installing this kit, depending on chiller specifications and user preference. These options are outlined below in the following paragraphs.

- Current Transformer Kit - Using *Table 1*, the technician must decide what current transformer (CT) kit is required based upon the specifications of the chiller motor. The installation technician must purchase the CT kit from YORK based upon this information.

TABLE 1 - CURRENT TRANSFORMER KITS

Motor Voltage	FLA	CT Ratio	CT Kit Part Number
200/600	65-111	200:1	366-82720-001
	112-224	350:1	366-82720-002
	225-829	700:1	366-82720-003
	830-1790	1400:1	366-82720-004
2300/4160	11-18	200:1	366-82720-001
	19-37	200:1	366-82720-001
	38-123	200:1	366-82720-001
	124-264	350:1	366-82720-002

- Condenser and chilled liquid pumps can be controlled by the OptiView Panel, as desired or necessary. Relays and other components, if required, must be field-sourced. Refer to the I/O board liquid pump contact ratings.

- Adjustable Mounting Assembly (P/N 375-29270-000) - An adjustable mounting assembly is available which simplifies mounting of the OptiView Control Center, the auxiliary junction box, and other components. The mounting assembly also allows for optimum placement and mounting height of the OptiView Control Center and other components.

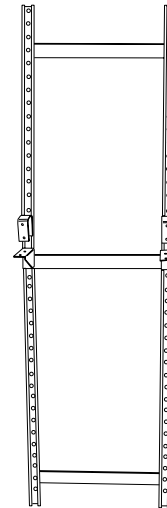

LD10248

FIGURE 2 - ADJUSTABLE MOUNTING ASSEMBLY

- Motor Bearing Temperature Sensors - Temperature sensors are included with this kit that, if installed, allow the operator to monitor the temperature of the compressor motor bearings. This feature increases the operating safety of the chiller. If bearing sensors are already installed on the chiller, these sensors replace those previously installed.

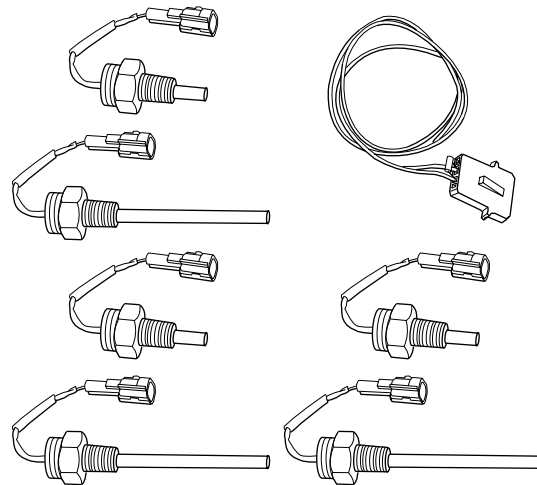

LD10412

FIGURE 3 - REFRIGERANT TEMP. SENSOR KIT

- Refrigerant Temperature Sensor - The refrigerant temperature sensor allows the liquid refrigerant temperature in the evaporator, condenser, and the chiller drop leg to be measured. This provides the operator or technician with enhanced information on chiller operating efficiency.

Due to differences in chiller design, evaporator and condenser sensors are provided in two different lengths, 0.68 inches and 3.00 inches. The correct length sensor should be selected based on the amount of space available in chiller evaporator and condenser shells.

ADDITIONAL ITEMS

There are several additional items that may be required in order to complete the installation of the OptiView Retrofit Kit. These items are primarily related to Trane competitive chiller originally equipped with the Trane UCP2 control panel.

Before proceeding with installation, identify if components referenced in the paragraphs below are currently installed on the chiller. Purchase components as the configuration of the chiller dictates.

- UCP2 equipped Trane chillers with a stepper module or actuator for vane actuation must have the vane stepper motor replaced. The replacement motor is Thompson Linear Actuator Part # SPO-00352-528, which is a standard 120 VAC vane control motor. This part can be ordered through Kaman Industrial Technologies (856) 284-7400.
- If the chiller will use a Trane purge unit that was originally controlled by the UCP2 Trane control panel, a Trane Human Interface Module (Trane part # MOD00377) must be purchased. This part can be ordered through MidWest Parts Center, (800) 368-8385.

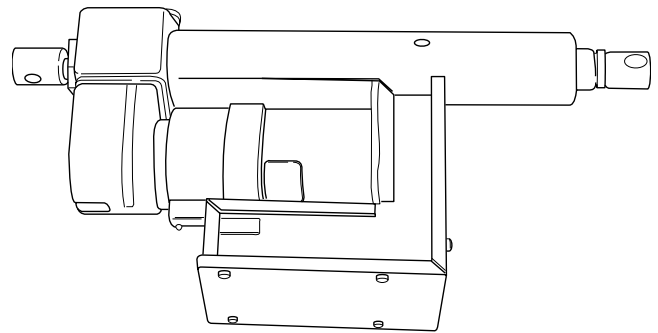

LD10408

FIGURE 4 - VANE CONTROL MOTOR

- UCP2 equipped Trane chillers which utilize a 2300 or 4160 VAC starter require a phase monitor safety device. The phase monitor is installed in the motor starter panel and ensures proper compressor motor control. The proper model of phase monitor must be selected by identifying the voltage of the potential transformers installed in the starter panel. Refer to *Table 2* for model identification.

TABLE 2 - PHASE MONITOR MODELS

Potential Transformer Voltage	Time Mark Phase Monitor Model
120 VAC	B158B
208 - 220 VAC	158B
380 VAC	EX158B
480 VAC	A158B

The phase monitor is available from the Time Mark Corporation by calling (800) 862-2875 or at www.time-mark.com.

The installing technician must procure common items to complete the installation of the OptiView Retrofit Kit. Before beginning, the technician should go over kit installation and set up to decide what items are required. The following list details field-sourced items which may be necessary to complete kit installation.

- Nitrogen gas
- 16 AWG 90° C, 600V wire
- 18 AWG 90° C, 600V wire
- 2-Wire shielded cable
- 3-Wire shielded cable
- Wiring terminals/connectors
- Wiring labels (alphanumeric)
- Terminal strips/blocks
- Cable straps
- Adhesive-backed cable strap mounts
- Conduit and conduit fittings
- Copper Tube, 1/4 inch
- Bulkhead fittings or isolators for copper tube
- Miscellaneous fittings (compression, braise, etc.)
- Liquid pump relays and bases (as required)
- Steel thread-o-lets
- Thermowells
- OptiView and junction box mounting brackets
- Tan touch-up paint (Trane color)
- Miscellaneous hardware to mount components
- Time delay repays (Fore Electro-Mechanical and Wye Delta Starters)

BILL OF MATERIALS

TABLE 3 - BILL OF MATERIALS

OPTIVIEW CONTROL CENTER RETROFIT KIT TRANE LOW PRESSURE CVHA, CVHB, CVHE, CVHF CHILLERS			
ITEM	PART NUMBER	DESCRIPTION	QTY
001-	025 37843 100	OPTIVIEW RETROFIT E-M STARTER CONTROL PANEL NEMA 4/12	1
002-	031 02406 001	Flash Minicard Programmed for Trane	1
003-	031 00947 000	Module, Current Control (CM-2)	1
004-	031 00210 000	Bridge, Diode	1
005-	575 00364 001	Resistor Assembly, Slide	1
010-	025 29106 000	Box, Auxiliary Junction - With Hinged Cover	1
011-	225 14385 002	Switch, High Pressure Cutout (HPCO)	1
012-	025 27509 010	Relay, 3PDT (3R)	1
013-	024 24953 000	Socket, Relay	1
014-	031 00808 000	Suppressor, Surge	16
015-	371 03728 000	RTD Module	1
020-	025 26204 000	Box, Junction - 5" X 3" X 11.5"	2
021-	025 26203 000	Cover, Junction Box - 5" X 11.5"	2
022-	025 14386 000	Switch, Differential Pressure Control (LOPCO)	1
023-	024 35382 000	Control Relay (CR1) - 120V, 30 Amp	1
024-	024 35383 000	Solid State Relay (PRV Control)	2
025-	031 02558 000	500 Ohm Resistor (PRV Control)	2
026-	331 00485 000	Varistor, Metal Oxide MOV, 120 VAC	2
030-	025 29964 000	Sensor, Temp 3000 Ohms @ 25°C 3/8 in. NPT x 3.00 in. (RT1, RT4, RT5, RT9)	4
031-	025 37825 001	Sensor, Temp 50000 Ohms @ 25°C 1/4 in. NPT x .68 in. (Inboard Bearing- RT15 & Outboard Bearing - RT16)	2
032-	025 37825 002	Sensor, Temp 50000 Ohms @ 25°C 1/4 in. NPT x 3.00 in. (RT3)	1
033-	025 37825 004	Sensor, Temp 50000 Ohms @ 25°C 1/2 in. NPT x .68 in. (RT2)	1
034-	026 32328 000	Well, Thermo	4
035-	013 01850 000	Compound, Heat Conductive	1
036-	013 01884 000	Adhesive, Sealing - Translucent	1
040-	025 29148 003	Low Oil Pressure Transducer	1
041-	025 29148 004	High Oil Pressure Transducer	1
042-	025 29148 009	Condenser Pressure Transducer	1
043-	025 29148 103	Evaporator Pressure Transducer	1
050-	025 36075 000	Harness, Temperature Sensor & Pressure Transducer	1
051-	575 00322 001	Harness, Electromechanical Wiring	1
052-	031 01799 000	Ribbon Cable, CM-2	1
055-	025 28954 000	Connector Plug Housing, 3 Position	5
056-	025 28951 000	Connector Plug Housing, 2 Position	8
057-	025 28952 000	Receptacle Contact - 070 Series	35
058-	025 28950 000	Collar, Rubber - Black 070 Series	35
059-	029 22962 000	Applicator, Amp Hand Tool	1
060-	021 14661 000	Nut, Expansion	6

TABLE 3 - BILL OF MATERIALS (CONT'D)

OPTIVIEW CONTROL CENTER RETROFIT KIT TRANE LOW PRESSURE CVHA, CVHB, CVHE, CVHF CHILLERS			
ITEM	PART NUMBER	DESCRIPTION	QTY
061-	021 14667 000	Screw, Type B Recessed Pan Head Self Tapping - #8 x 1¼ inches	8
062-	021 01133 000	Lock Washer, #8 Internal Tooth	4
063-	021 16149 000	Screw, Type F - 8-32 x 1/2 inch	6
064-	021 13726 000	Screw, Type F - 8-32 x 3/4 inch	2
065-	021 13722 000	Screw, Type F - 6-32 x 3/4 inch	2
066-	013 01835 000	Enamel - Blue Caribbean Touch Up	2
070-	035 03908 000	Label, Warning	1
071-	035 20981 000	Manual, Renewal Parts - 160.10-RP1	1
072-	035 18611 000	Diagram, Wiring - Trane Low Pressure Dual Shell (15 sheets)	1
080-	035 20980 100	Manual, Installation - 160.10-N1	1
081-	035 20982 100	Manual, Operating - 160.10-O1	1
082-	035 20983 100	Manual, Service - 160.10-M1	1
090-	375 29270 100	Assembly, Control Panel Adjustable Mounting (Optional)	1
090A-	021 31158 306	Angle, 3 Hole Adjustable Corner (090 Kit Item)	3
090B-	021 31158 302	Angle, 2 Hole Adjustable Corner (090 Kit Item)	2
090C-	021 08388 000	Screw, Hex Head Cap - 1/2-13 x 1 inch (090 Kit Item)	11
090D-	021 13482 000	Nut, Hex – 1/2-13 (090 Kit Item)	7
090E-	021 08279 000	Lock Washer, Helical Spring - 1/2 inch (090 Kit Item)	11
090F-	021 31158 106	Nut, Channel – 1/2-13 (090 Kit Item)	4
091-	021 17269 000	Assembly, Nut/Washer	4
092-	021 13204 000	Screw, Cap Hex Head - 1/4 -20 x 1.0 inch	4
093-	021 01153 000	Lock Washer, Internal Tooth - 1/4 inch	4
094-	021 12507 000	Lock Washer, Internal/External Tooth - 1/4 inch	4
095-	021 05165 000	Washer, Plain 9/32 Id X 5/8 OD	4
096-	021 00451 000	Nut, Hex – 1/4 - 20	4

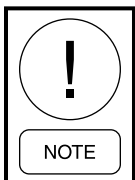

Prior to installation of the OptiView Retrofit Kit, inspect all parts and verify that all parts on the bill of material have been included with the kit.

OPTIVIEW RETROFIT KIT PART IDENTIFICATION

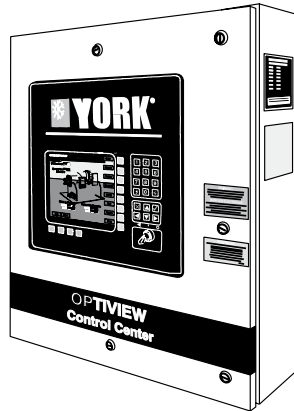

LD10282

FIGURE 5 - OPTIVIEW CONTROL CENTER

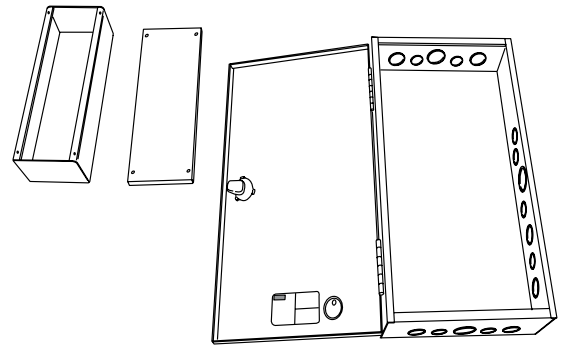

LD10245

FIGURE 8 - AUXILIARY AND JUNCTION BOXES

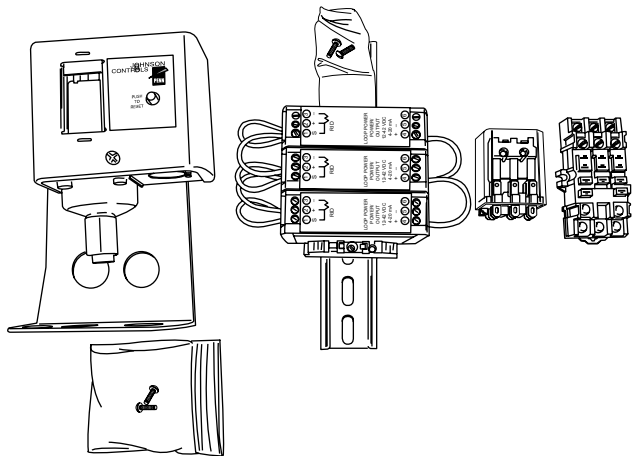

LD10246

FIGURE 6 - HP CUTOUT SWITCH, RTD MODULE, 3R RELAY, RELAY SOCKET

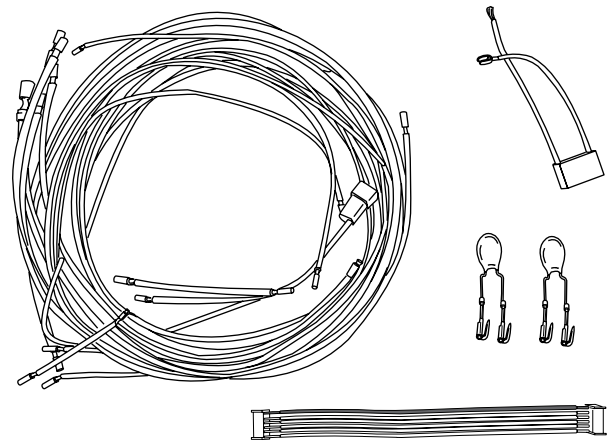

LD10247

FIGURE 9 - E-M WIRING HARNESS, RIBBON CABLE, VARISTORS, SURGE SUPPRESSOR

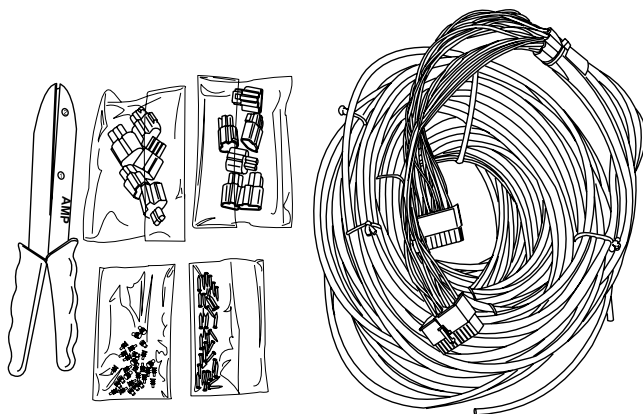

LD10249

FIGURE 7 - SENSOR WIRING HARNESS, CONNECTORS, TERMINALS, APPLICATOR CRIMP TOOL

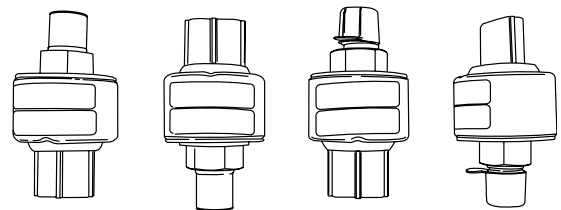

LD10250

FIGURE 10 - PRESSURE TRANSDUCERS

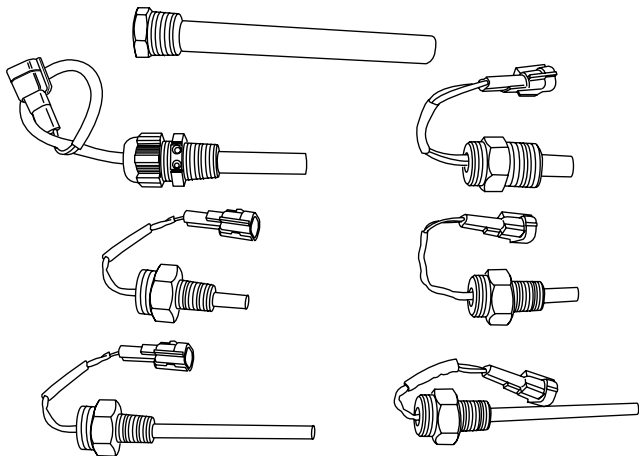

LD10251

FIGURE 11 - THERMOWELL, TEMPERATURE SENSORS

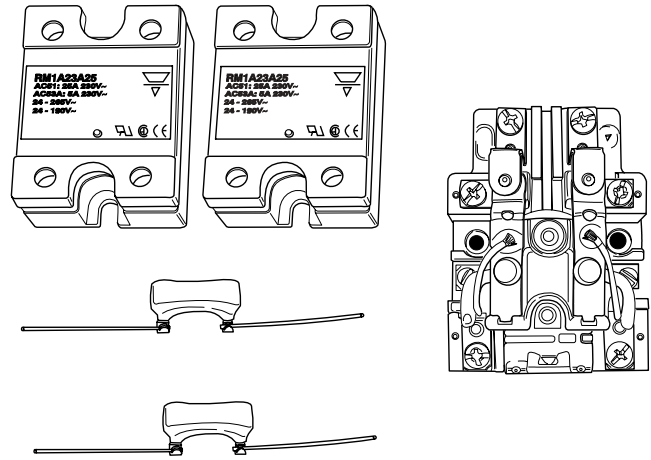

LD10398

FIGURE 13 - PRV SOLID STATE RELAYS, RESISTORS, CR1 STARTER CONTROL RELAY

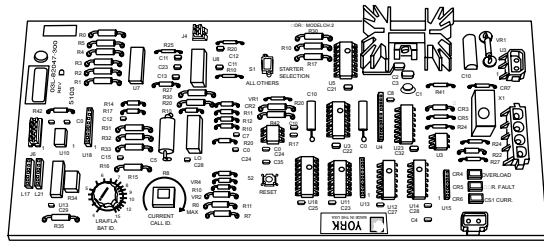

LD10396

FIGURE 12 - CURRENT MODULE (CM-2), DIODE RECTIFIER, SLIDE RESISTOR ASSEMBLY

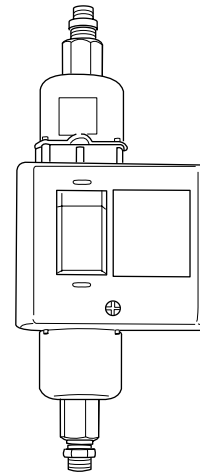

LD10400

FIGURE 14 - LOW OIL PRESSURE CUTOUT SWITCH

SECTION 2 - OPTIVIEW RETROFIT KIT INSTALLATION

PRIOR TO BEGINNING

Read these instructions thoroughly before proceeding with the installation of the OptiView Retrofit Kit! All field wiring must conform to National Electric Code (USA) or Canadian Electric Code as well as all local building and wiring codes. The installing technician must completely understand the scope of this kit to avoid potential problems, ease installation, and determine additional components or hardware that may be required to install this kit.

The chiller must be in proper operating condition prior to installation of the OptiView Retrofit Kit. YORK is NOT responsible for pre-existing chiller problems, conditions and poor maintenance.

Only install new sensors in locations where sensors already exist. Adding additional options/ sensors originally not on the chiller, will increase the installation cost.

SITE PREPARATION AND DISASSEMBLY

1. If possible, retrieve operating data from the previous chiller controls. Record data such as operating hours, number of starts, oil temperature setpoint, etc. in Appendix D. Remove the service rating plate from the Trane control unit.
2. Stop chiller operation and disconnect power to the chiller by using proper lock-out/tag-out procedures. Inform the proper personnel of the lock-out/tag-out to the chiller.



Electrical Shock Hazard! Lock-out/Tag-out the chiller using the proper procedure, otherwise injury, death or damage to the chiller may occur.

3. Stop condenser and chilled liquid flow to the chiller.
4. Clean the area around the chiller so the area is free from dirt, debris, and obstruction. Locate an area to lay out parts from the OptiView Retrofit Kit to aid in part identification and retrieval.



Asphyxiation Hazard! Refrigerant is under pressure and poses an asphyxiation hazard if pressure is not properly relieved and refrigerant evacuation is not performed properly.

5. Using the procedure described in the Trane chiller manuals, relieve chiller pressure. Remove refrigerant and oil following the procedure outlined in the Trane chiller manual and all EPA requirements.
6. Pressurize the chiller with nitrogen gas. Exposing chiller internal components to air will promote corrosion and contamination.

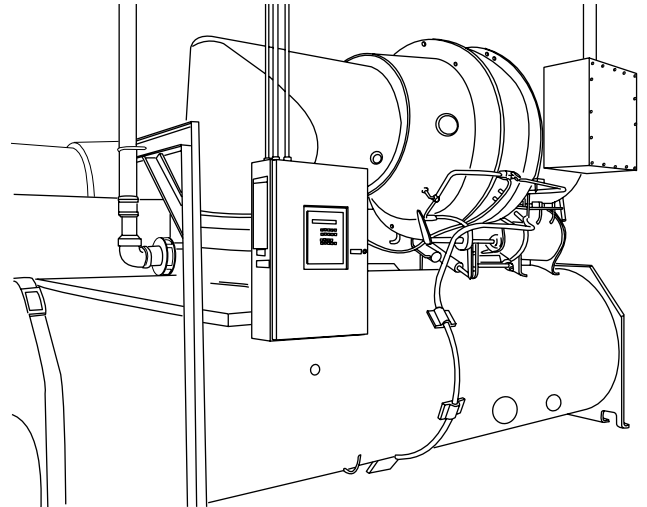

LD10269

FIGURE 15 - TRANE CHILLER

7. Identify and label the wiring from the chiller purge system, if so equipped. Disconnect the wires from the Trane control unit.
8. Identify and label the wiring for the pre-rotation vane motor. Disconnect the wires from the Trane control unit. If the Trane unit utilizes a stepper module and motor (UCP2 controls), remove the motor from the chiller.
9. Identify and label the wires from the oil heater, oil pump motor, oil pump start relay and the capacitor. Disconnect the wires from the Trane control unit.
10. Identify and label all wires from the motor bearing and winding temperature sensors, as equipped. Identify each phase of winding temperature sensors. Disconnect the wires from the Trane control unit.
11. Identify and label all wiring which runs from the motor starter panel to the Trane control unit. Disconnect the wires from the Trane control unit.

12. Identify the wiring for the condenser and chilled liquid flow switches connected to the control panel. Identify the wiring, input/output type, and function for remote devices or modules installed on the chiller.
13. Disconnect remaining wiring and conduit from the Trane control unit.
14. Carefully remove the Trane control unit from the mounting brackets. Use care not to damage the unit during removal and retain all hardware for possible use in mounting of the OptiView Panel.

OPTIVIEW RETROFIT KIT INSTALLATION



Modification or adding components to the OptiView panel may cause damage to panel components by electrical interference. Do not modify the OptiView panel unless instructed to do so.

OptiView Panel/Junction Box Mounting

1. Pre-fit the OptiView panel to the original control center mounting brackets. Modify the existing brackets as needed to mount the panel. If the mounting brackets cannot be modified to accept the panel, the size of the chiller shells disallow this, or control panel relocation is necessary, use the optional adjustable mounting assembly (ITEM #090).
2. If the optional mounting assembly is being used, locate and secure the assembly to the floor and other anchor points such as the original panel mounts using hardware supplied with the kit (ITEM #090A, 090B, 090C, 090D, 090E). Refer to *Figure 19* for hardware item locations. Adequate hardware used to secure the mounting assembly to the floor must be field sourced.
3. Secure the OptiView Control Center (ITEM #001) to the mounting location using kit hardware (ITEM #092, 093, 094, 095, 096) or adequate field sourced hardware. Mount the panel at a height that is easily accessible to operators and securely so that vibration is minimized.
4. Find a location to mount the auxiliary junction box (ITEM #010) above or below the OptiView panel.

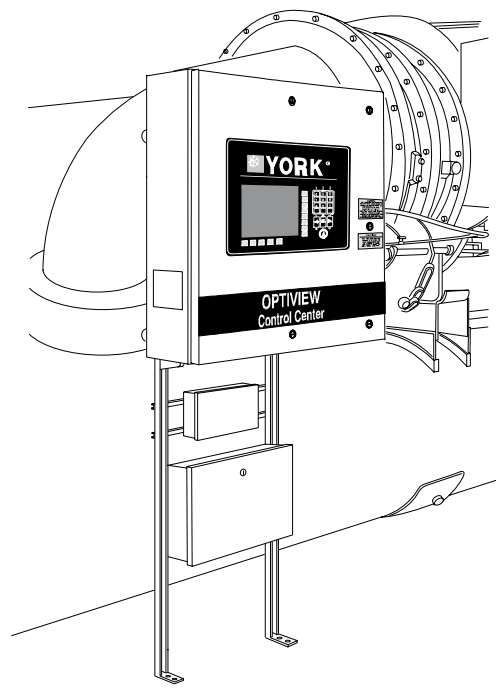

LD10376

FIGURE 16 - OPTIVIEW PANEL MOUNTING

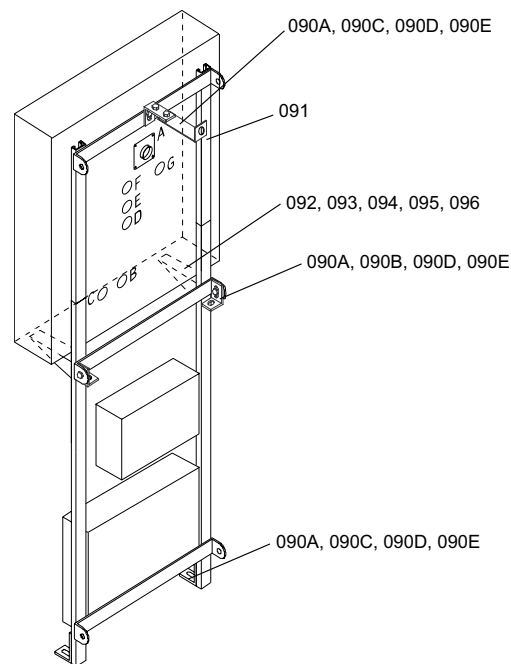

LD10376

FIGURE 17 - MOUNTING ASSEMBLY HARDWARE

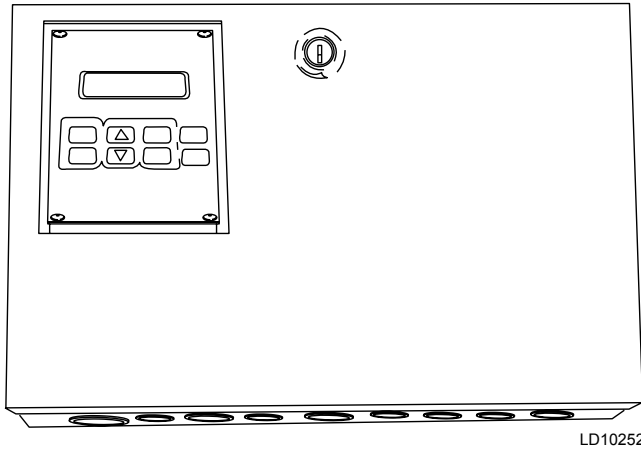

FIGURE 18 - TRANE PURGE HUMAN INTERFACE

5. Chillers equipped with Trane purge units originally controlled by the Trane panel require the Trane Human Interface Module (Trane part # MOD00377). The Trane purge unit will not operate properly unless this module is installed. Position and cut a 3.75 inch square cutout in the front cover of the auxiliary junction box. Using the interface as a template, mark drill locations for the four holes to mount the interface on the junction box cover. Check that the drill marks will center the interface properly, then drill the mounting holes. Do not mount the interface at this time.
6. Find a location to mount a small junction box (ITEM #020, 021) central to the auxiliary junction box and OptiView panel. Wiring from the purge unit, PRV motor, vent line solenoid, etc. will be routed through this box to and from the auxiliary junction box and OptiView panel.
7. Secure the junction boxes to the mounting locations using suitable field-sourced brackets and hardware.
8. Locate the high pressure cutout (ITEM #011), the 3 pole double throw (3R) relay and socket (ITEM #012, 013), and the motor sensor RTD module (ITEM #015). Mount these items inside the junction box, placing components in positions that are easily accessible for wiring. If applicable, make sure the components will not interfere with the Trane purge human interface module.
9. Relocate the oil pump start relay and capacitor, located in the Trane oil pump junction box, to the auxiliary junction box, as desired.

10. Install surge suppressors (ITEM #014) on the coil terminals of the 3R relay and the oil pump start relay.
11. If the chilled and condenser liquid pumps will be controlled by the OptiView panel, install the pump control relays in the auxiliary junction box (as required). The relays and components for liquid pump control must be field-sourced.

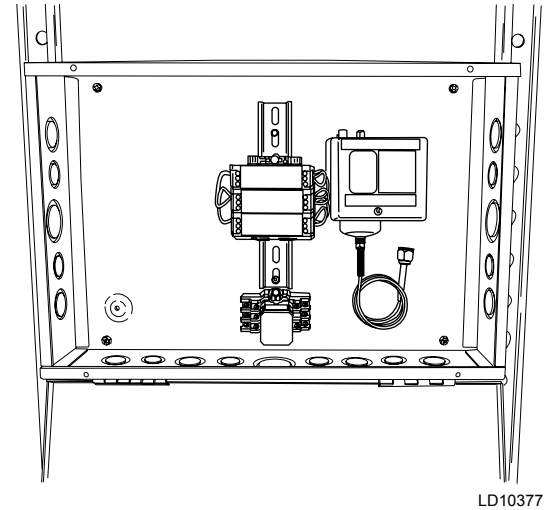
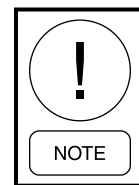

FIGURE 19 - AUXILIARY BOX COMPONENTS



The RTD signal conditioner DIP switch positions must be checked. The OptiView Panel will not be able to read the motor winding temperature sensors unless the switches are set to the proper position.

12. Carefully remove each motor temperature RTD signal conditioner from the DIN rail and check the position of the dip switches on the conditioner. DIP 6 and DIP 8 must be “ON”. The remaining switches should be in the “OFF” position.
13. Mount a small junction box (ITEM #020, 021) in a location convenient to the high and low oil pressure sensors.

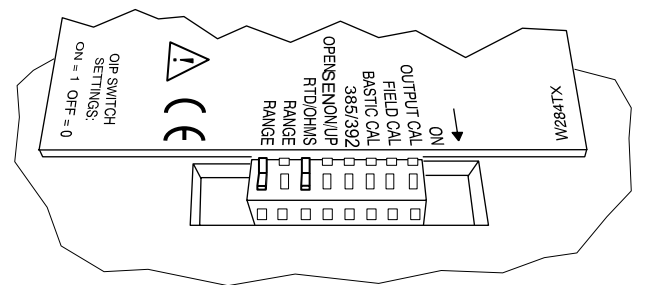
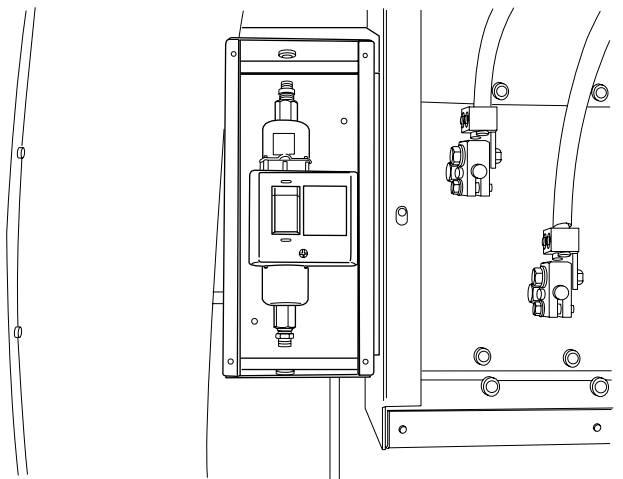
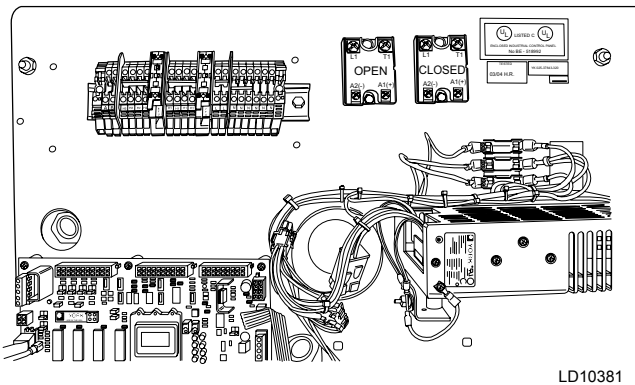

FIGURE 20 - RTD CONDITIONER DIP SWITCH

**FIGURE 21 - OIL PRESSURE SAFETY SWITCH**

14. Install the differential oil pressure safety switch (ITEM #022) inside the small junction box.
15. Mount the PRV Solid State Relays (ITEM #024) in the appropriate location using 8-32 x 1/2 inch screws (ITEM #063). Mark the left relay "OPEN" and the right relay "CLOSED" using a suitable marking device or label. Relay wiring will be performed later in the installation process.

**FIGURE 22 - PRV SOLID STATE RELAYS**

Chiller Purge Unit

16. Determine the type of purge unit installed on the chiller. Several types may be used; each are wired differently.

Trane Purge Unit

17. If the Trane Human Interface Module is required, install the module into the hole cut in the front door of auxiliary junction box. Secure the module using adequate field-sourced hardware.

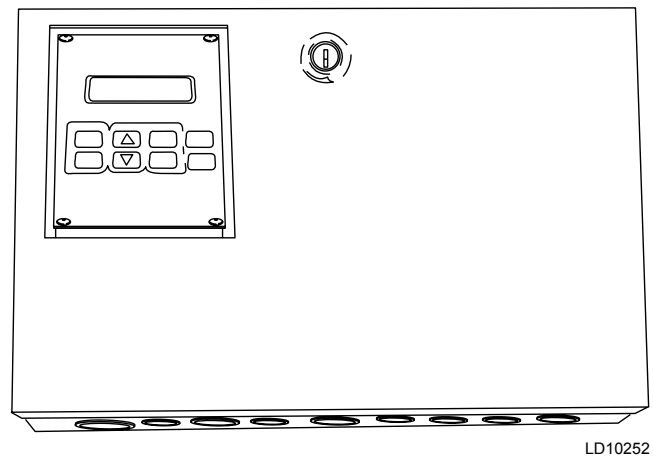
**FIGURE 23 - TRANE HUMAN INTERFACE**

18. Using shielded 2 and 3 wire cable, create and label wiring to go from the Human Interface to the purge unit. Do not route the shielded cable near sources of power such as purge power wiring, as this may interfere with the signals between the interface and purge unit. Connect the cable to the corresponding connections at the interface and purge unit, referring to sheet 10 of the kit wiring diagram (ITEM #072) for proper wiring connections.
19. Create and label a wiring harness to be routed from the purge unit to the small junction box mounted central to the OptiView panel. Six (6) wires are required for the purge unit. The wire designations are as follows:
 - "Run" signal wires from I/O board connections 35 and 36 in the OptiView Control Panel to the Trane purge unit control board.
 - Wires for the purge remote fault. These wires will be routed from J16 in the Trane purge unit to the digital I/O board in the OptiView panel.
 - Purge power supply wires. The purge must be powered by a 20 amp fused 120 VAC power supply, on a dedicated circuit. This power can be connected from the starter transformer or other source.
 - Install a jumper between terminals 5 and 6 of J1. The jumper allows the refrigerant compressor to run.

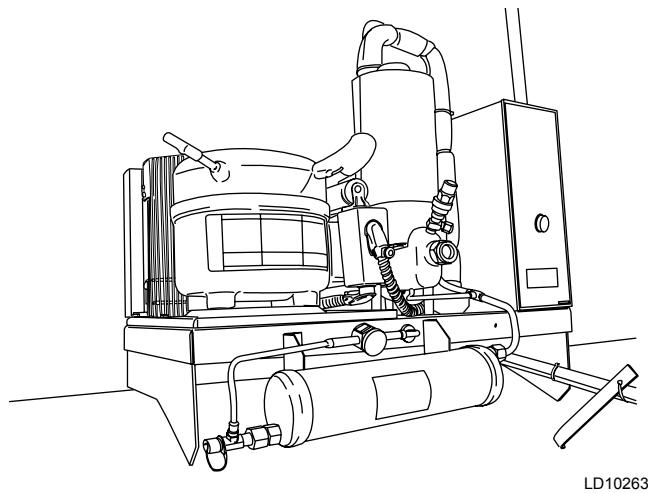

FIGURE 24 - TRANE PURGE UNIT

20. A wire must also be connected from terminal 3 of TB1 to terminal 2 of connector J26 in the Trane unit for the run indicator input signal. Use sheets 9 and 10 of the kit wiring diagram (ITEM #072) to verify proper connections. Proceed to step 25.

SkyGuard II Purge Unit

21. Create and label a wiring harness to be routed from the SkyGuard II purge unit to the small junction box mounted central to the OptiView panel. Six (6) wires are required for the purge unit. The wire designations are as follows:
 - “Run” signal wires from I/O board connections 35 and 36 in the OptiView Control Panel to terminals one and three in the purge unit.
 - Ground wire from the purge unit to ground G1 in the OptiView panel.
 - Remote fault/alarm relay wires to go from the purge alarm relay to the digital I/O board in the OptiView panel.
 - Purge power supply wires. The purge must be powered by a 20 amp fused 120 VAC power supply, on a dedicated circuit. This power can be connected from the starter transformer or other source.

22. If not pre-existing, a wire must be connected from terminal 1 in the purge unit to L1 in the purge unit for the run indicator input signal. Use sheets 9 and 10 of the kit wiring diagram (ITEM #072) to verify proper connections. Proceed to step 25.

TurboGuard II Purge Unit

23. Create and label a wiring harness for the TurboGuard II purge unit. The purge wiring harness will be routed from the purge unit to the small junction box and then to the OptiView Control Center.

Since the purge unit previously only operated with a “run” signal from the Trane controls, the purge must be fully wired to the OptiView Control Center to allow full use of the purge features. Use sheets 2, 3, 9, and 10 of the kit wiring diagram (ITEM #072) for TurboGuard II purge wiring references.

24. Install surge suppressors (ITEM #014) at the purge oil solenoid valve coils and the purge air exhaust valve coil. Install a suppressor for the purge oil motor.

Purge Canister

25. If the chiller is equipped with a purge canister alarm, ensure the power supply wiring to the alarm is shielded cable and that wiring to power supply and alarm is correct. Verify the 2R power interrupt relay is wired properly.

Retrofit Kit Sensors

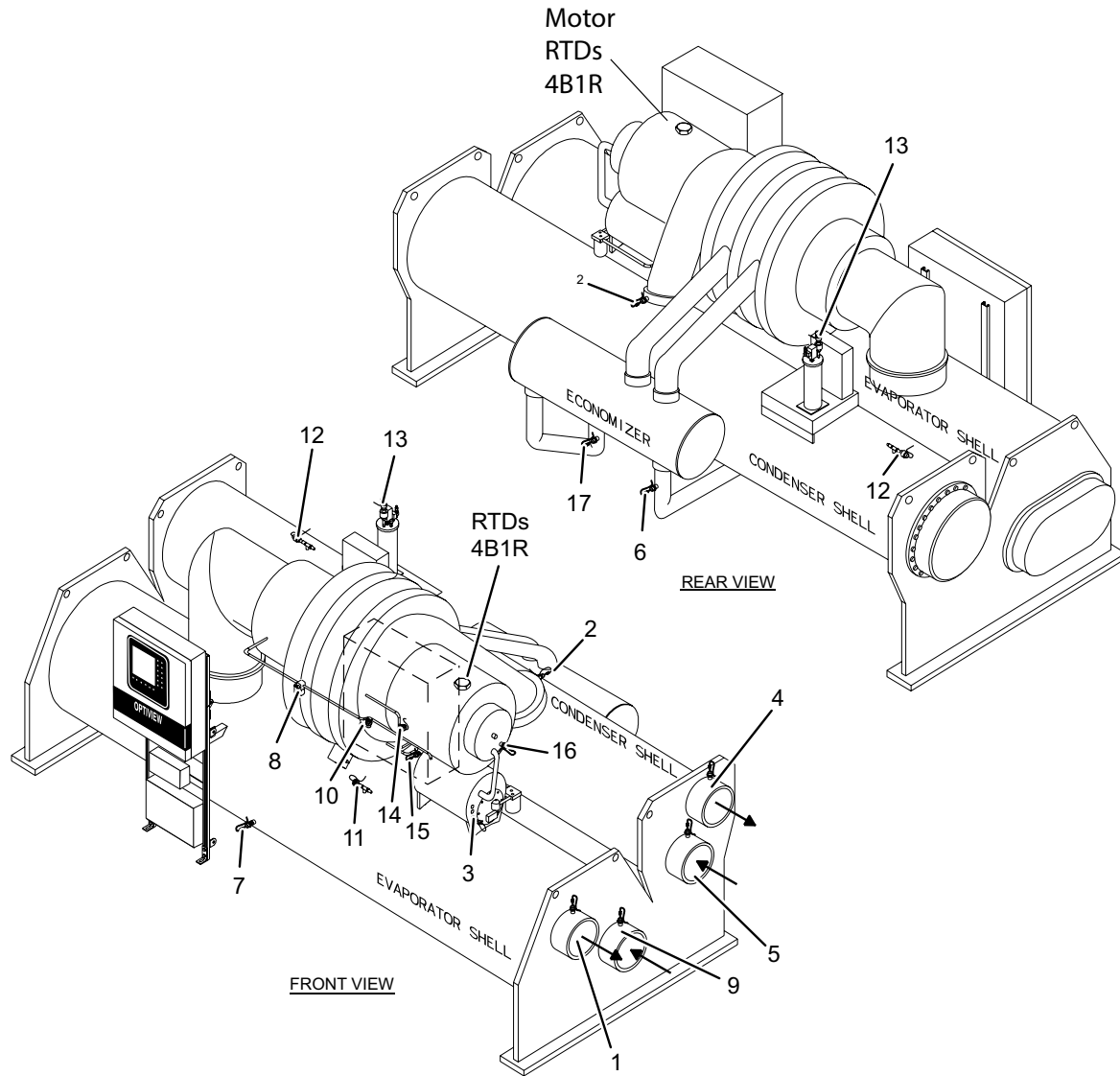

LD10453

FIGURE 25 - TYPICAL CVHE, CVHF SENSOR/SOLENOID LOCATIONS

TABLE 4 - TYPICAL CVHE, CVHF SENSOR/SOLENOID LOCATIONS

ITEM	DESCRIPTION	ITEM	DESCRIPTION
1	Leaving Chilled Liquid Temperature Sensor	10	Low Oil Pressure Transducer
2	Discharge Temperature Sensor	11	Evaporator Pressure Transducer
3	Oil Temperature Sensor	12	Condenser Pressure Transducer
4	Leaving Condenser Water Temperature Sensor	13	Purge Pressure Transducer*
5	Entering Condenser Water Temperature Sensor	14	High Oil Pressure Transducer
6	Drop Leg Refrigerant Temperature Sensor*	15	Inboard Bearing Temperature Sensor
7	Evaporator Refrigerant Temperature Sensor*	16	Outboard Bearing Temperature Sensor
8	Vent Line Solenoid Valve	17	Condenser Refrigerant Temperature Sensor*
9	Entering Chilled Liquid Temperature Sensor		

*Denotes Optional Component

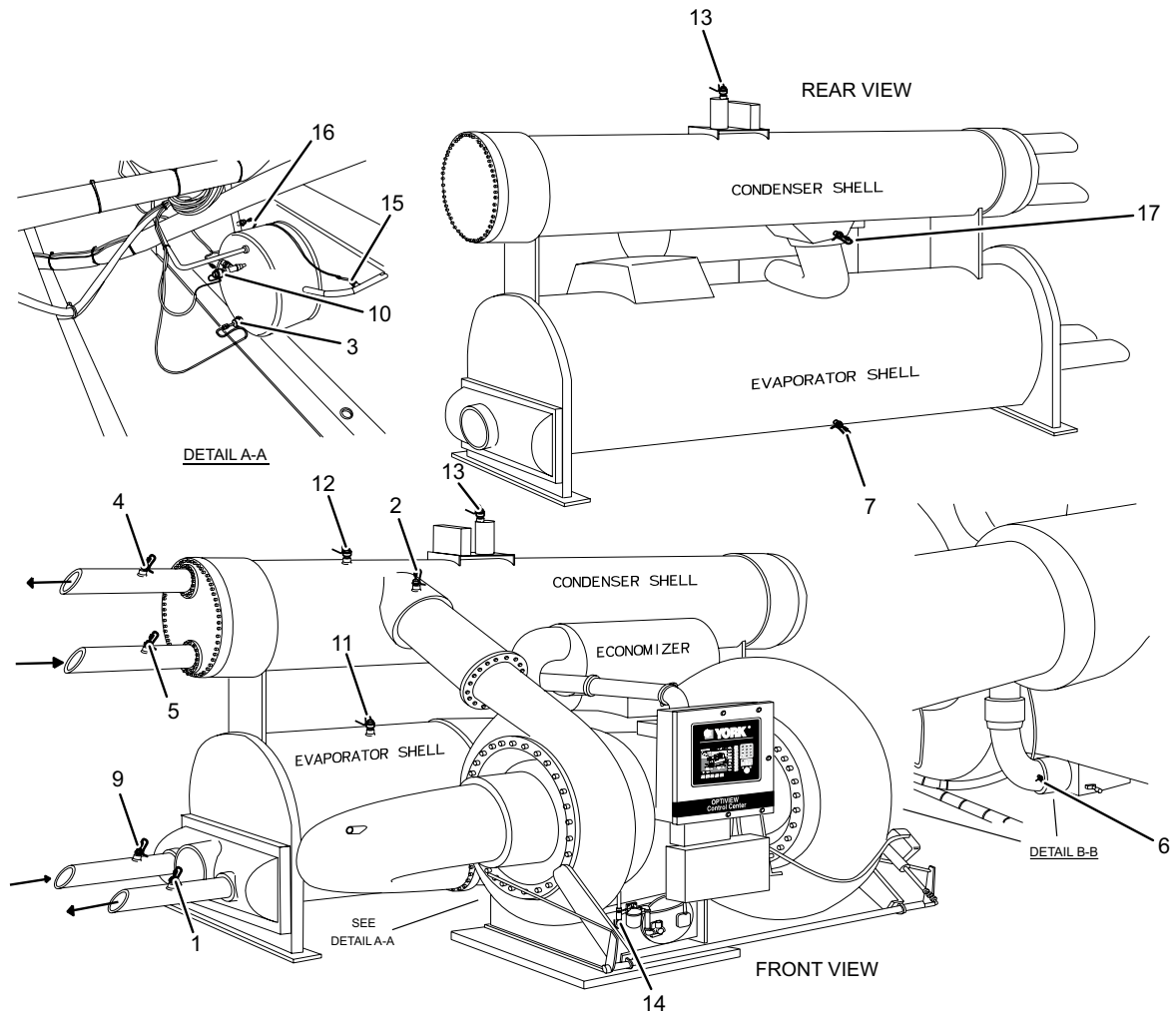

LD10454

FIGURE 26 - TYPICAL CVHB SENSOR LOCATIONS

TABLE 5 - TYPICAL CVHB SENSOR LOCATIONS

ITEM	DESCRIPTION	ITEM	DESCRIPTION
1	Leaving Chilled Liquid Temperature Sensor	10	Low Oil Pressure Transducer
2	Discharge Temperature Sensor	11	Evaporator Pressure Transducer
3	Oil Temperature Sensor	12	Condenser Pressure Transducer
4	Leaving Condenser Water Temperature Sensor	13	Purge Pressure Transducer*
5	Entering Condenser Water Temperature Sensor	14	High Oil Pressure Transducer
6	Drop Leg Refrigerant Temperature Sensor*	15	Inboard Bearing Temperature Sensor
7	Evaporator Refrigerant Temperature Sensor*	16	Outboard Bearing Temperature Sensor
8	Vent Line Solenoid Valve - Not Applicable	17	Condenser Refrigerant Temperature Sensor*
9	Entering Chilled Liquid Temperature Sensor		

*Denotes Optional Component

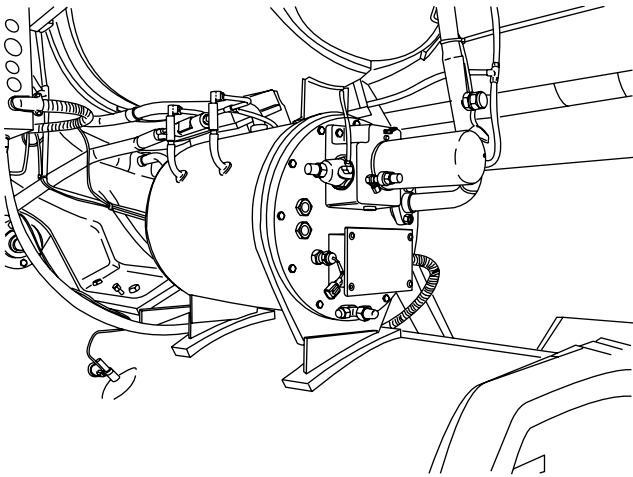

LD10262

FIGURE 27 - OIL TEMPERATURE SENSOR

26. Remove the existing Trane oil sump temperature sensor from the oil sump and install a 50K ohm 1/4 in. NPT x 3.0 in. temperature sensor supplied with the kit (ITEM #032). In some instances, the technician may be required to install a new thermowell or drill and tap directly into the oil sump housing to install this sensor. Use care not to get any shavings and debris in the oil sump.

If the sensor is being installed in a thermowell, apply thermal compound (ITEM #035) to the sensor prior to installation. Use sealant (ITEM #036) to seal the threads of the sensor.

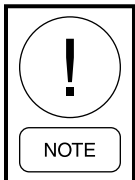

When installing sensors which require NPT fittings/thread-o-lets, use fittings which are steel, not iron, as iron fittings are porous and will increase the chances for leakage. Use sealant (ITEM # 036) to seal the threads of the sensor and fittings.

27. Install thermowells (ITEM #034) and 3K ohm 3/8 in. NPT x 3.0 in. temperature sensors (ITEM #030) in the condenser water entering and leaving pipes. Place the sensors as close to the condenser shell as possible, on a straight section of pipe. Use sealant (ITEM #036) to seal the threads of the thermowell. Apply thermal compound (ITEM #035) to each sensor prior to installation.

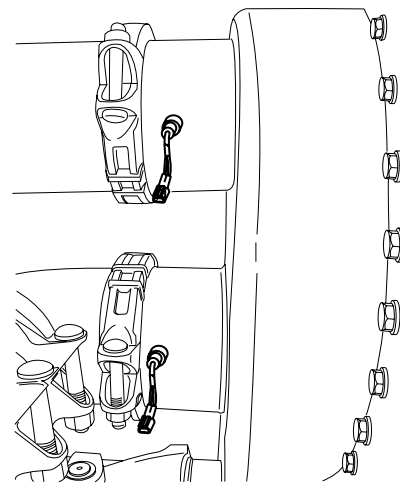

LD10265

FIGURE 28 - CONDENSER WATER SENSORS

28. Install thermowells (ITEM #034) and 3K ohm 3/8 in. NPT x 3.0 in. temperature sensors (ITEM #030) in the chilled water entering and leaving pipes. Place the sensors as close to the evaporator shell as possible, on a straight section of pipe. Apply sealant (ITEM #036) to the threads of the thermowell and apply thermal compound (ITEM #035) to each sensor prior to installation.
29. Install a “tee” fitting off the oil sump return line. The existing Trane fitting for the low (sump) oil pressure sensor or another “tee” fitting placed in-line may be used. This fitting must allow installation of the low oil pressure sensor (ITEM #040) and the low side of the oil pressure safety switch tubing to be plumbed. Plug the existing Trane sensor location if not utilized.

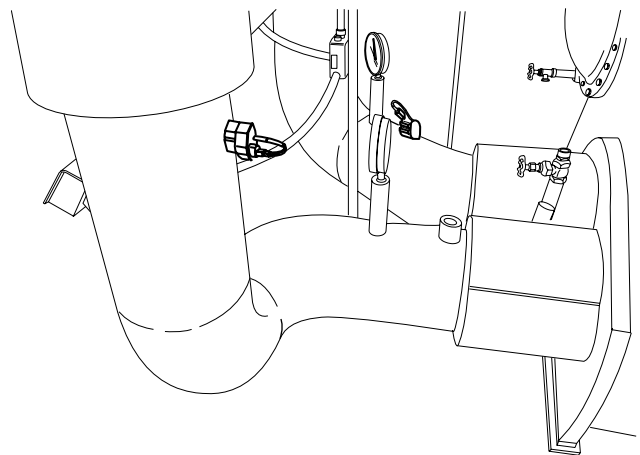

LD10257

FIGURE 29 - CHILLED LIQUID SENSORS

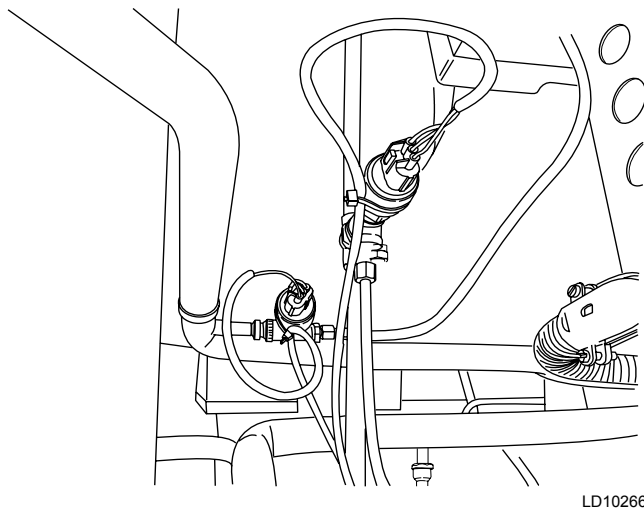

FIGURE 30 - OIL PRESSURE TRANSDUCERS

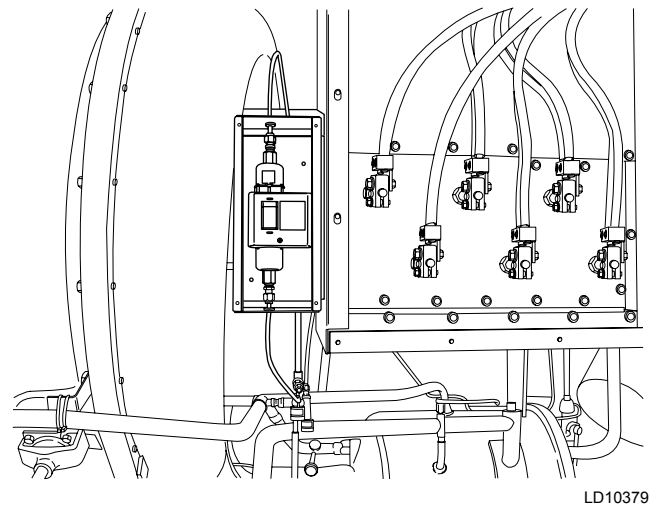

FIGURE 31 - OIL PRESSURE SAFETY SWITCH

30. Install a “tee” fitting off the oil line between the oil filter output and compressor bearing input. The existing Trane fitting for the high oil pressure sensor or another “tee” fitting placed in-line may be used. This fitting must allow installation of the high oil pressure sensor (ITEM #041) and the high side of the oil pressure safety switch tubing to be plumbed.
31. Install the low oil pressure transducer (ITEM# 040) and the high oil pressure transducer (ITEM# 041) in the appropriate fitting. Use sealant (ITEM #036) to seal the threads of the sensors.
32. Route suitable 1/4 inch copper tubing from the oil line “tee” fittings to the high and low sides of the differential oil pressure safety switch previously installed in the small junction box. Protect the tubing at junction box from possible vibration damage using field-sourced 1/4 inch bulkhead fittings or rubber isolators.
33. Create and label a wiring harness to go from the oil pressure switch to the small junction box. Install terminal strips or blocks in the junction box to keep wiring clean. Source terminal strips or blocks which have a large amount of connections, as wiring from most external chiller controls will be routed through the junction box. Use sheets 9 and 10 of the wiring diagram for oil pressure switch connections.

34. Route suitable 1/4 in. copper tubing for the high pressure cutout switch (ITEM #011) out of the auxiliary junction box, using a field-sourced 1/4 in. bulkhead compression fitting or rubber isolator at the box. Connect the copper line at the condenser with a “tee” fitting that includes a 1/4 in. NPTF port for the condenser pressure transducer. Install the “tee” as close to the condenser shell as possible.
35. Install the condenser pressure transducer (ITEM #042) in the copper tubing for the high pressure switch at the “tee”. Use sealant (ITEM #036) to seal the threads of the transducer and fittings.

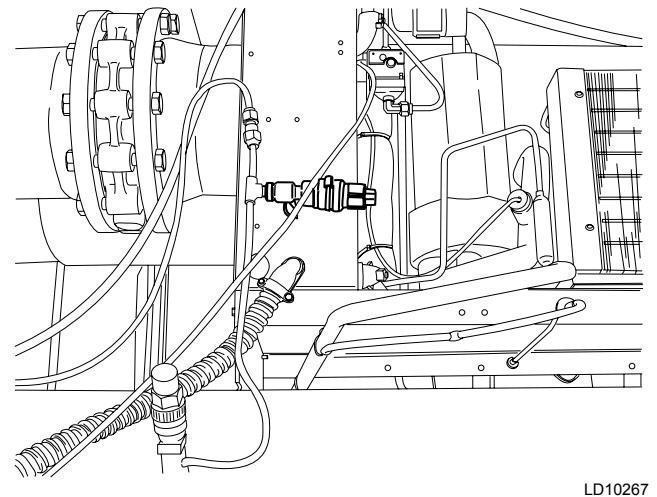
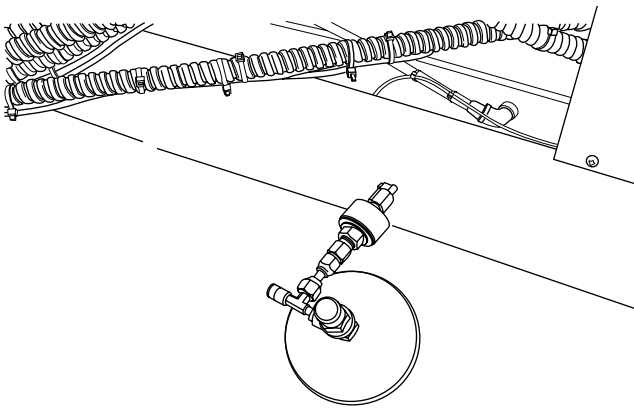
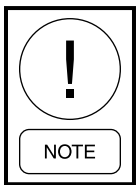

FIGURE 32 - CONDENSER PRESSURE TRANSDUCER



LD10253

FIGURE 33 - EVAPORATOR PRESSURE TRANSDUCER



Before installing the Retrofit Kit sensors, verify the chiller is pressurized with nitrogen gas to avoid corrosion and contamination of the chiller internal components.

NOTE

36. Install the evaporator pressure transducer (ITEM # 043) in the evaporator shell at the existing location. If necessary, install a “tee” fitting to retain a fitting for the pressure gauge. Use sealant (ITEM #036) to seal the threads of the sensor and fittings.

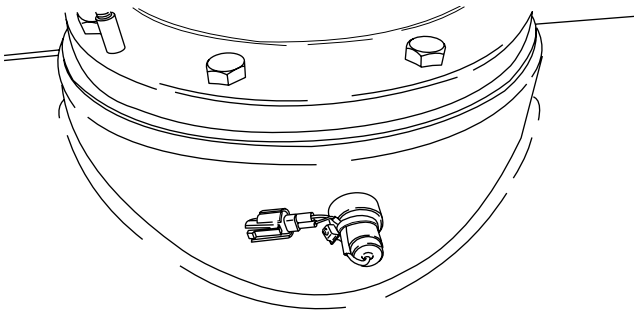

LD10256

FIGURE 34 - DISCHARGE TEMPERATURE SENSOR

37. Weld a 1/2 in. NPTF thread-o-let in the compressor discharge, as close to the coupling flange as possible. Do not install the fitting in any cast portions, such as the compressor housing, as this may allow leakage. Using care not to damage the threads inside the fitting, drill a hole in the coupling flange for the 1/2 in. NPT x 0.68 in. discharge temperature sensor. (ITEM #033). Use sealant (ITEM #036) to seal the sensor threads and install the sensor in the weld fitting.

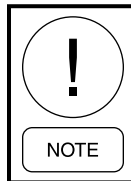

Installing the inboard and outboard motor bearing sensors provide increased operating safety of the chiller.

NOTE

38. Install a 50k ohm 1/4 in. NPT x 0.68 in. sensor (ITEM #031) for the outboard bearing into the fitting on the motor end plate. If this fitting is not present, place a “tee” fitting with a 1/4 in. NPTF port in the oil line leading from the compressor motor to the oil sump. Use sealant (ITEM #036) to seal the sensor threads.

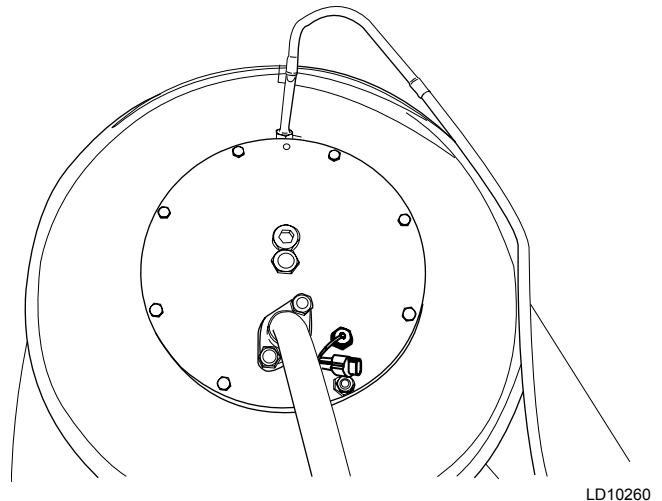

LD10260

FIGURE 35 - OUTBOARD BEARING SENSOR

39. Install the 50k ohm 1/4 in. NPT x 0.68 in. inboard bearing temperature sensor (ITEM #031) in the line leading from the compressor motor to the oil sump. Install a “tee” fitting into the oil line to allow sensor installation. In some cases, a fitting may be already located where the oil line enters the oil sump. Use sealant (ITEM #036) to seal the sensor threads.

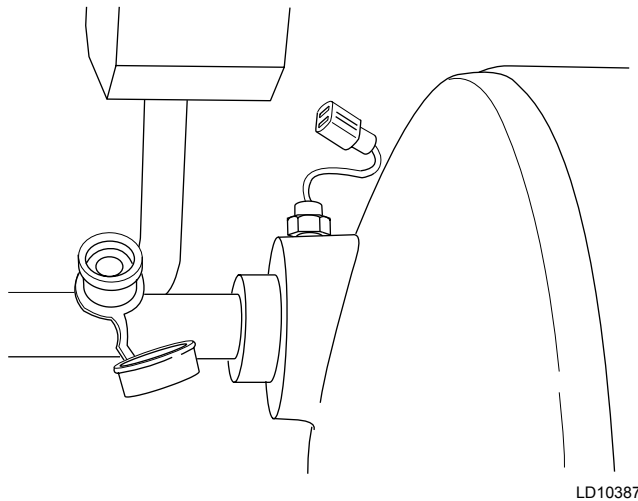

FIGURE 36 - INBOARD BEARING SENSOR

Refrigerant Sensors (Optional Kit)

40. Three sensors must be installed for the refrigerant sensor kit (ITEM #100). Find a location on the condenser shell or just below the shell, on the Trane economizer pipe, to install the condenser refrigerant sensor (KIT ITEM #101 or 102). If required, weld a 1/4 in. NPTF thread-o-let fitting at the install location, then center and drill a 7/16 in. hole for the sensor. Select a sensor (0.68 in. or 3.00 in.) based upon the amount of space available at the install location; the longer sensor will be more accurate. Thread the sensor in the fitting, using sealant (ITEM #036) on the threads of the sensor.

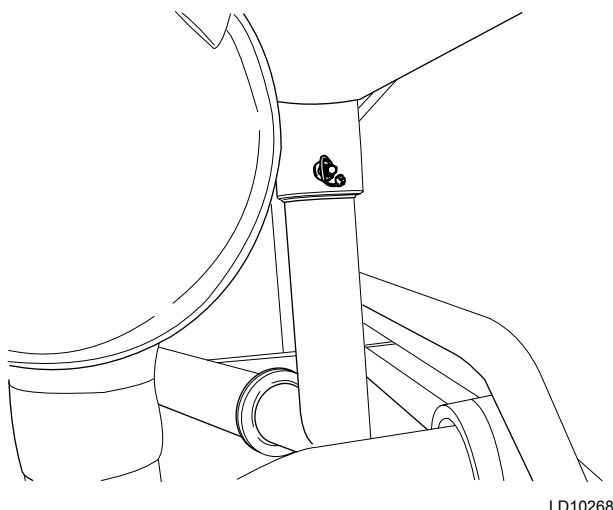

FIGURE 37 - CONDENSER TEMPERATURE SENSOR

41. Remove the existing evaporator temperature sensor. If necessary, weld a 1/4 in. NPTF thread-o-let fitting in the evaporator shell to accept the evaporator refrigerant temperature sensor (KIT ITEM #101 or 102). Select the sensor (0.68 in. or 3.00 in.) based upon the amount of space available at the install location; the longer sensor will be more accurate. Install the sensor into the pipe fitting, using sealant (ITEM #036) on the threads of the sensor and fittings.

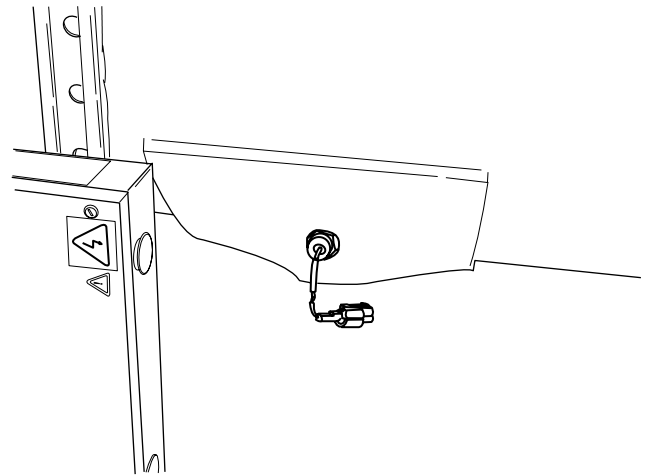

FIGURE 38 - EVAPORATOR TEMPERATURE SENSOR

42. Locate a position on the piping which runs from the Trane economizer to the evaporator to install the drop leg sensor (KIT ITEM #101 or 102). Weld a 1/4 in. NPTF thread-o-let fitting at the install location, then center and drill a 7/16 in. hole for the sensor. Select the sensor (0.68 in. or 3.00 in.) based upon the amount of space available at the install location; the longer sensor will be more accurate. Thread the sensor in the fitting, using sealant (ITEM #36) on the threads of the sensor.

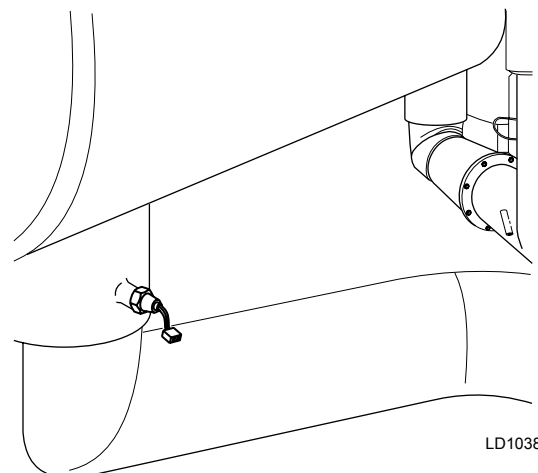

FIGURE 39 - DROP LEG TEMPERATURE SENSOR

Retrofit Kit Wiring

43. Locate the sensor wiring harnesses (ITEM # 050, KIT ITEM #103). Route the cables through cutout "A" in the back wall of the OptiView Panel. Connect the cable shields to a ground terminal at cutout "A" inside the panel. Connect the wiring harnesses to the microboard locations J7 (optional), J8, and J9. Use sheet 9 of the kit wiring diagram (ITEM #072) for proper wiring connections.
44. Locate the wiring receptacles and collars (ITEM #057, 058), two and three terminal wiring connectors (ITEM #056 and 055), and terminal hand tool (ITEM #059). Layout the wiring harness to each sensor, using sheets 9 and 10 of the wiring diagram (ITEM #072) as a guide to determine which cable is designated for each sensor. Do not route the cables close to sources of electric current, as this will affect the sensor's signal to the panel. Cut the cable to necessary lengths to allow proper fitment to each sensor.

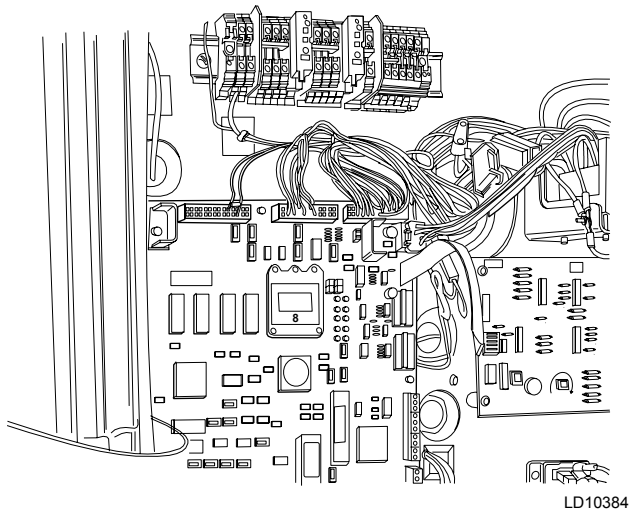
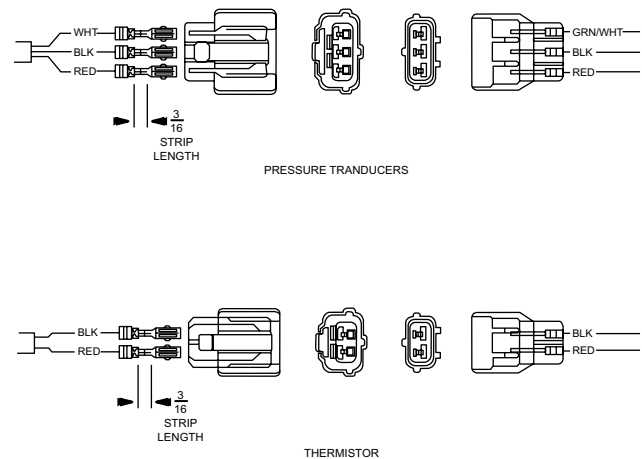

FIGURE 40 - HARNESS MICROBOARD CONNECTIONS

45. Using the terminal hand tool, install connectors and receptacles for each sensor on the sensor wiring harness. Two-wire connectors are for the temperature sensors, while three-wire connectors are for pressure transducers. If the purge canister alarm and/or purge pressure transducer are being used, terminate the wires for these sensors as well.



LD10243

FIGURE 41 - HARNESS TERMINAL CONNECTIONS

46. In order for the microboard to read the condenser refrigerant temperature sensor properly, a resistor is factory installed in the harness between connector pin 16 and 5 at the J7 connection on the microboard.
47. Once the sensor wiring harness is terminated, connect the cables to their respective sensors. Use cable straps to secure the cable to the sensor or fitting. This will help to prevent damage to the sensor and cable, should the cable be accidentally pulled upon. Use cable straps to bundle the cable together to provide a clean installation.

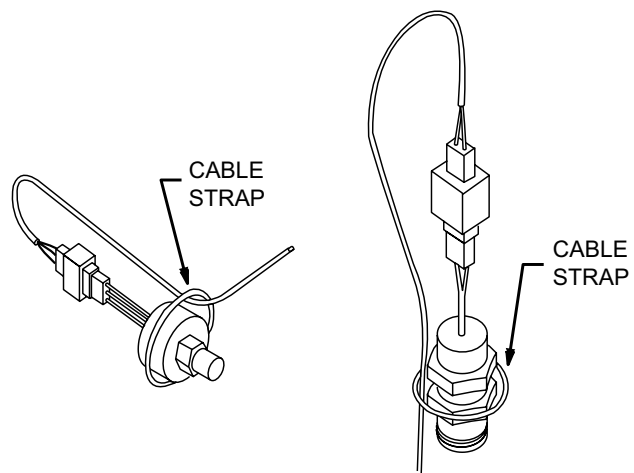

LD10281

FIGURE 42 - SENSOR CABLE STRAP DETAILS

48. Measure and record the resistance (in Appendix D) of each motor temperature winding sensor. Some Trane chillers may be equipped with a thermal switches for motor winding temperature. See Step #50 for wiring of thermal switches.

Refer to *APPENDIX A* for sensor resistance specifications at given temperatures. As the compressor motor should not be warm, measured resistance will be at ambient (room) temperature. Sensors measured as open or are out of this specification may be damaged; note this for further testing during commissioning.

49. Create and label a wiring harness for the motor winding temperature sensors using shielded cable. The harness will be routed from the motor RTD junction box on the motor to the auxiliary junction box. Refer to the Trane wiring diagram to identify the sensor for each current phase. Connect a ground wire from the “common” wire terminal to the RTD junction box.

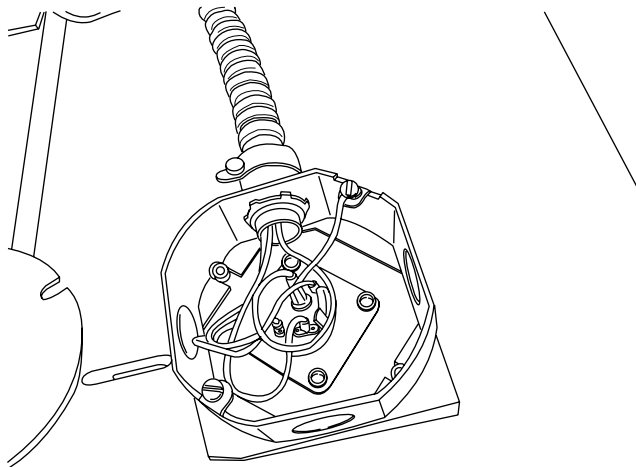

LD10261

FIGURE 43 - WINDING TEMPERATURE RTD BOX

50. Route the harness from the motor RTD junction box on the motor to the auxiliary junction box. The cables must not be routed close to sources of power or electrical fields, as this may affect sensor readings. Connect the RTD cables to the corresponding RTD signal conditioner for each current phase in the auxiliary junction box. Use sheets 7 and 8 of the kit wiring diagram for wiring references. Connect cable shields to ground in the auxiliary junction box.

If the chiller is equipped with a thermal switch, create and label a wiring harness to be routed from the switch to the small junction box. The wiring will later be routed from the small junction box to the digital I/O board in the OptiView cabinet. Use wiring diagram sheets 4 and 10 for wiring references.

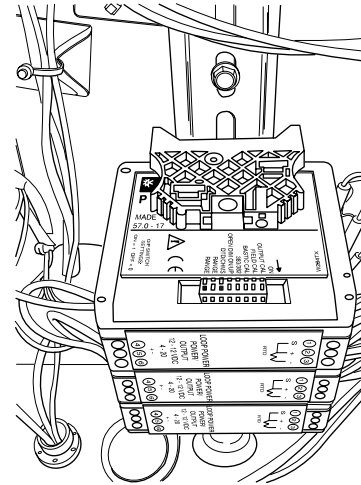

LD10385

FIGURE 44 - MOTOR RTD SIGNAL CONDITIONERS

51. Create and label a shielded cable wiring harness to connect the motor RTD signal conditioners to the analog I/O board in OptiView Control Panel.
52. Create and label a wire harness using two wire shielded cable to go from each bearing sensor to the OptiView panel. Install wiring receptacles, covers, and two pin connector plugs (ITEM #056, 057, 058) on the sensor end of the harness. The wiring will be routed into the OptiView panel along with the motor temperature sensor shielded cable.
53. Route the motor sensor wiring out of the auxiliary junction box, along with the bearing temperature sensor wiring, to cutout “A” or “F” in the back panel of the OptiView control panel. Use field-sourced NEMA-4 conduit fittings to route the wires through the OptiView panel. Refer to sheets 5, 9, and 10 of the wiring diagram for proper wire routing and connections to terminal block 7 (TB7) and the analog I/O board.

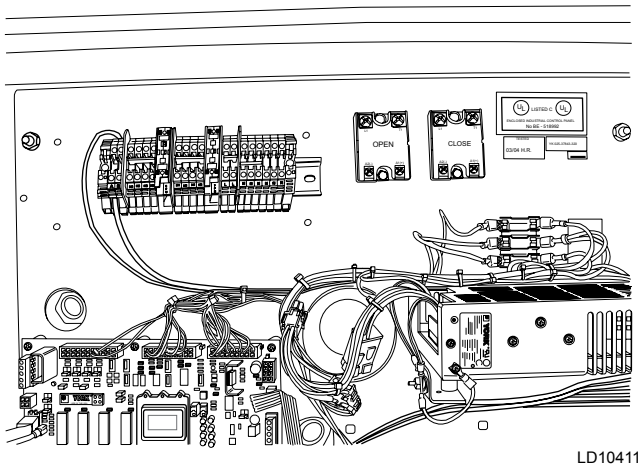

LD10411

FIGURE 45 - MOTOR RTD CABLE ROUTING

54. Install a surge suppressor (ITEM #014) on the coil of the vent line solenoid valve (as equipped). Route wiring and conduit for the valve to the small junction box. Use field-sourced terminal strips or blocks in the junction box to keep wiring harness installation clean. Label the wiring and terminal strips appropriately.

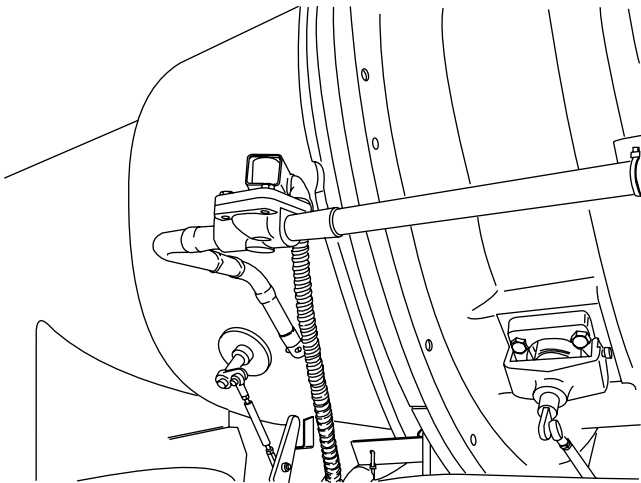

LD10244

FIGURE 46 - VENT LINE SOLENOID

55. If the Trane chiller originally utilized a stepper motor, install the standard 120 VAC motor (Kaman Industries Part # SPO-00352-528) onto the chiller. Install a MOV varistor (ITEM #026) on the open and close circuits of the PRV motor. Use sheets 10 of the kit wiring diagram for wiring connections in *Figure 61 on page 38*.

56. Create and label a wiring harness to go from the PRV motor and vane motor switch to the small junction box. Route the wiring to the small junction box through suitable conduit and label the terminal strips appropriately for wire connections.

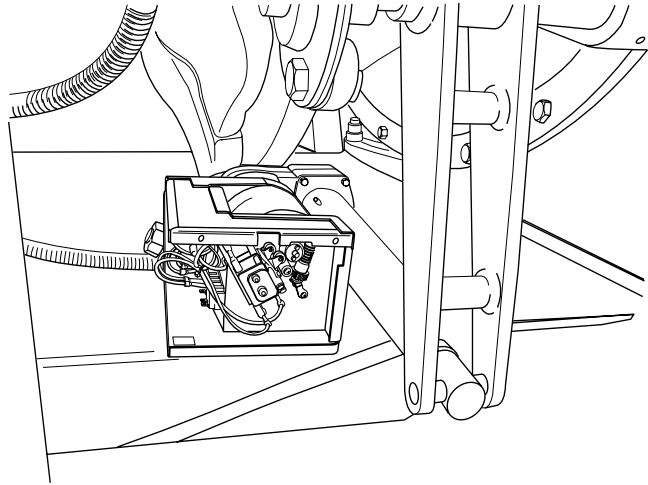

LD10388

FIGURE 47 - PRV MOTOR

57. Create and label a wiring harness to go from the sump oil heater and the oil pump start relay to the auxiliary junction box. Connect the oil pump wiring to the 3R relay, referring sheets 7 and 8 of the kit wiring diagram for wiring details. Use terminal strips or blocks in the auxiliary junction box to keep wiring installation clean.

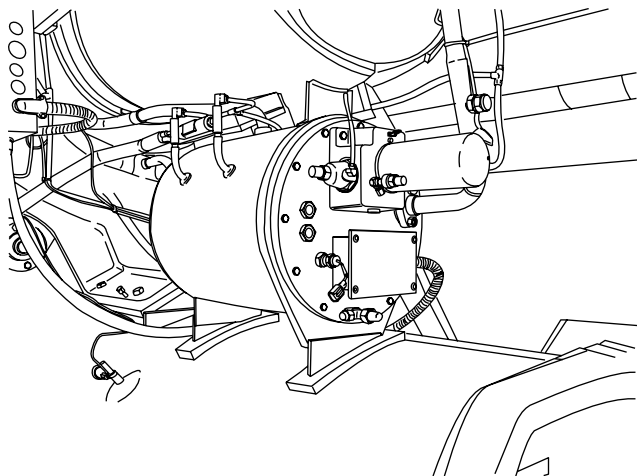

LD10262

FIGURE 48 - OIL SUMP

58. Create and label a wiring harness to go from the high pressure cutout switch and the 3 pole double throw (3R) relay installed in the auxiliary junction box to the terminal strips in the small junction box. Connect the wiring for the high pressure cutout switch as shown on sheets 7 and 8 of the kit wiring diagram (072).
59. For applications which require the OptiView Panel to operate the condenser and chilled liquid pumps, create and label a wiring harness that will go from the pump relays to the terminal strips in the small junction box.
60. Route the wiring for the high pressure cutout switch, 3R relay, oil sump heater, ground wire (G2), and the liquid pump relays (as equipped) to the small junction box.

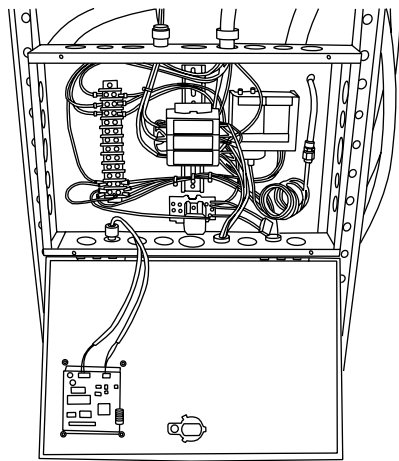

LD10456

FIGURE 49 - AUXILIARY JUNCTION BOX COMPONENTS

61. Create and label a wiring harness to connect all components wired to the small junction box to the OptiView control panel. This harness should include the wiring for the motor stator thermostat (motor cooling pump) and motor winding thermal switch digital inputs, as equipped. Route all wiring from the small junction box to cutout “B” on the back wall of the OptiView panel using field-sourced NEMA-4 conduit and fittings.

Use sheets 7 and 8 of the kit wiring diagram for proper wire routing and connections. Note that the 120 VAC power supply for the oil pump is fused at “3FU” (wire 111) in the control panel and is connected to contact 7 of the 3R relay.

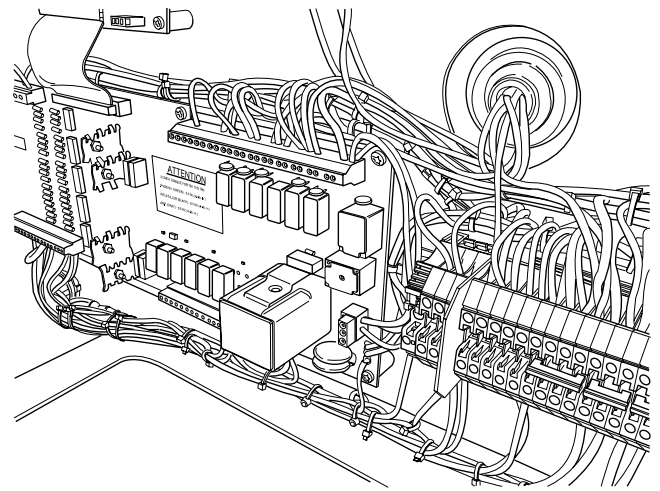

LD10389

FIGURE 50 - INPUT/OUTPUT BOARD

62. Install a 500 ohm resistor (ITEM # 025) across terminals “A1” and “A2” of each PRV solid state relay. Create, label, and connect the internal panel wiring for the two PRV solid state relays. Be sure the open and close relays are connected the corresponding PRV motor circuit. Refer to sheets 1, 8, and 10 of the wiring diagram (ITEM #072) for wiring details.

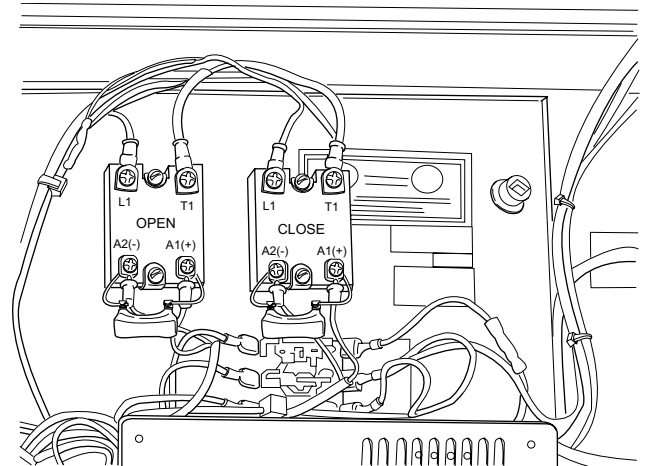

LD10390

FIGURE 51 - PRV SOLID STATE RELAYS

63. Label and connect a wire from terminal block 1, terminal 17 (TB1-17) to terminal block 5, terminal 22 (TB5-22) of the I/O board for proper oil heater operation.

64. For applications which require the OptiView panel to control the condenser liquid pump, assess the wiring/supply required in order for the pump to operate. If 120 volt power is required for the pump, a jumper wire must be connected between terminal block 2, terminal 150 (TB2-150) and terminal block 5, terminal 22 (TB5-22) on the I/O board. Terminals 150 and 151 can operate as a dry contact if 120 volt supply is not required.
65. For applications that have a motor refrigerant pump, connect the motor stator thermostat input to the OptiView external digital I/O board at terminal block P2, terminal 6. Connect the output to the cooling pump at terminal block P2, terminal 5. Refer to the kit wiring diagram, sheet 3 for wiring connections.
66. Make the connections for any remote devices or cycling devices to the microboard or I/O board. Refer to sheet 8 of the kit wiring diagram for wiring connections.

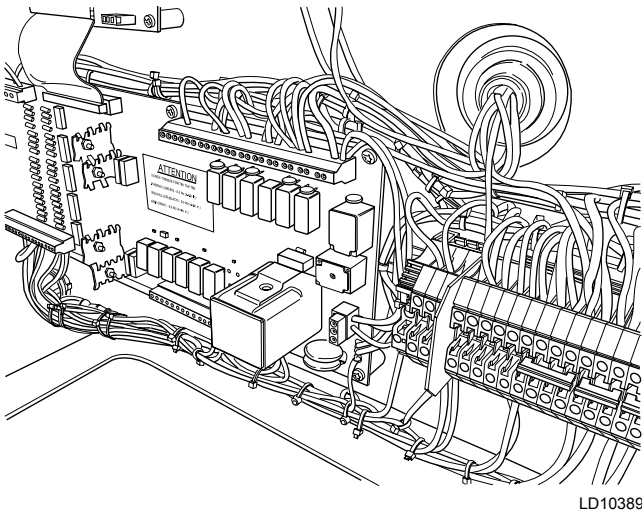

FIGURE 52 - INPUT/OUTPUT BOARD

Printer

67. If a printer is being connected at this time, find a suitable location and secure the printer. The OptiView Control Unit can operate with printers that communicate via RS-232 serial communications. Connect the printer to the microboard shielded cable at the "J2" COM1 connection. *Table 6* lists printer connections to J2 terminals. The OptiView Control Center software will be configured for the printer during commissioning. Refer to the *Section 4 - Printers in the OptiView Control Center Retrofit Kit - Trane Operation Manual (Form 160.10-01)* for more details on printer setup.

TABLE 6 - PRINTER MICROBOARD CONNECTIONS

MICROBOARD CONNECTION	CONNECTION DESCRIPTION
J2-4	TX - Transmission, data to printer
J2-2	DSR - Busy signal from printer to microboard
J2-9	Printer ground
Cabinet	Cable shield

Current Transformers / Current Module

68. Locate the CM-2 current control module board (ITEM #003), six #8 x 1.25 in. screws (ITEM #061) and six expansion nuts (ITEM #060). Find the mounting position below the OptiView power supply and mount the CM-2 board in the panel using these items. Refer to *Figure 55* for proper current module component mounting positions and orientation.

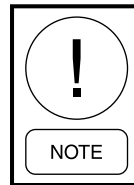

Not applicable with VSD installations. VSD installations use an ACC Board through the 2430 -001 boards. No ACC Board is for 3430 Board kits.

69. Find the diode bridge (ITEM #004), two 8-32 x 1/2 in. screws (ITEM #063), and two lock washers (ITEM #062). Mount the diode bridge to the panel wall using the hardware.
70. Locate the slide resistor assembly (ITEM #005), two #8 x 1.25 in. screws (ITEM #061), and two lock washers (ITEM #062). Mount the assembly to the panel wall.
71. Connect the CM-2 ribbon cable (ITEM #052) to OptiView Microboard and the CM-2 board. The striped wire on the cable should face down at both connections.
72. Connect P1 to J1, P2 to J2, and P6 to J3 on the CM-2 board. Refer to the kit wiring diagram, sheet 7, to ensure proper connections.
73. Connect the slide resistor A and B wires to the positive (+) and negative (-) terminals on the diode rectifier, respectively. Refer to the kit wiring diagram (#072), sheet 7, to ensure proper connections.

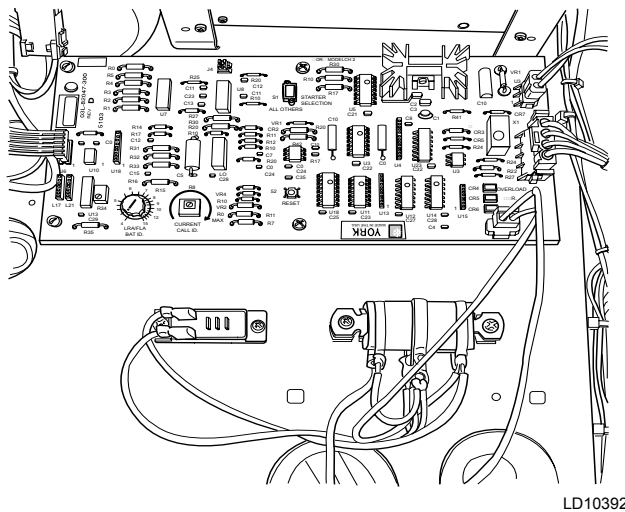

FIGURE 53 - CURRENT MODULE (CM-2) BOARD

- 74. Determine the type of starter and motor utilized by the chiller. Different manufacturers and types of starters are possible; components are different for each type.
- 75. For all starters wiring changes may need to be made in the field.
- 76. For all high voltage (2300V - 4160V) starters, a phase monitor (or voltage-free dry contact) must be installed in-line between the circuit for terminals 1 and 53 in the starter panel. This contact will open when the compressor motor is in an overload condition. For low-voltage starters, this device is optional.

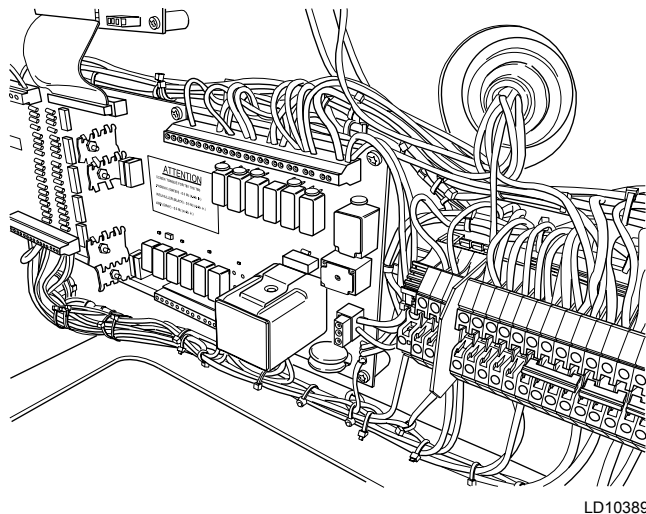

FIGURE 54 - I/O BOARD AND TB6

- 77. Install the current transformer (CT) kit selected from *Table 1 on page 12*. The CTs can be mounted in the motor terminal or electromechanical starter box, use the instructions provided with the CT kit for proper mounting. Note that the CTs only sense current from motor leads one, two, and three and must be oriented identically when mounted.
- 78. Shunt (bridge) the pre-existing current transformers in the motor starter cabinet.

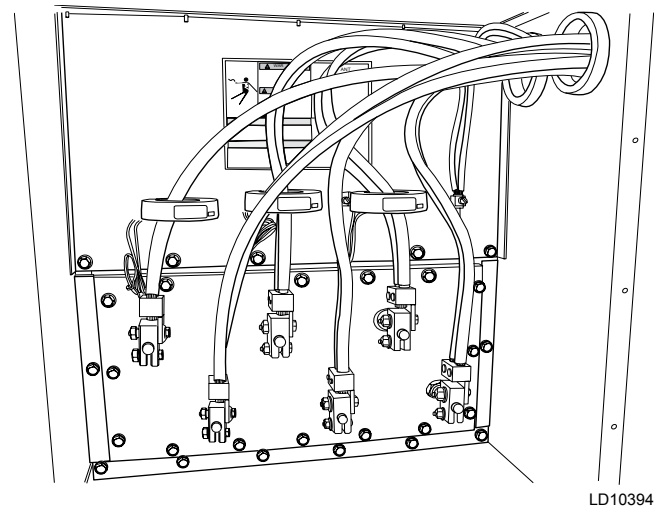

FIGURE 55 - CURRENT TRANSFORMERS

- 79. In order for the CTs to send the proper signal to the OptiView panel, motor leads may need to be passed through the CTs several times before the motor leads are connected to the power supply. The number of passes required depends upon motor voltage, CT ratio, and motor full load amps. Refer to *Table 7* for the corresponding motor lead passes required.

TABLE 7 - CT INSTALLATION TABLE

MOTOR VOLTAGE	FLA	CT RADIO	MOTOR LEAD PASSES REQUIRED
200/600	65-111	200:1	1
	112-224	350:1	1
	225-829	700:1	1
	830-1790	1400:1	1
2300/4160	11-18	200:1	3
	19-37	200:1	2
	38-123	200:1	1
	124-264	350:1	1

80. Use the electromechanical wiring harness (ITEM #051) to connect the CTs to the OptiView panel. Route the harness through cutout "D" in the back wall of the Optiview panel. Use a NEMA-4 conduit fitting to route the harness through the OptiView cabinet. Connect the harness to the diode bridge rectifier at terminals 97, 98, and 99. Use 16 AWG 90° C, 600V copper wire to connect CTs mounted remotely to the control panel.
81. Calculate the resistance the slide resistor assembly connected to the CM-2 board must be adjusted at for proper system operation; refer to *Table 8*. The constant used in the calculation is correlated with the number of motor lead passes and motor voltage.
82. Slide resistor resistance is measured at the P1 plug. P1 must be disconnected from J1 on the CM-2 board when measuring resistance. The resistance is adjusted by loosening the locking screws and sliding the resistors until the reading is at the calculated value.

Properly adjusted resistors will register 0.90 - 1.05 VDC across the J1-1 and J1-2 terminals while the motor is running at full load amps (FLA).

TABLE 8 - SLIDE RESISTOR CALCULATION

MOTOR VOLTAGE	FLA	CT RADIO	"R" RESISTER SETTING
200/600	65-111	200:1	R=1.282 (CT Ratio)/FLA
	112-224	350:1	
	225-829	700:1	
	830-1790	1400:1	
2300/4160	11-18	200:1	R=0.247 (CT Ratio)/FLA
	19-37	200:1	R=0.370 (CT Ratio)/FLA
	38-123	200:1	R=0.740 (CT Ratio)/FLA
	124-264	350:1	

83. Set the starter selection switch at "S1" on the CM-2 board to the position which corresponds to the type of starter employed by the motor. Place the switch in the "UP" position for wye-delta starters and autotransformer/reactor starters which use a 57% power tap. Place the switch in the "DOWN" position for across-the-line starters and autotransformer/reactor starters which use a 65% power tap.
84. Calculate the lock rotor amp to full load amp ratio (LRA divided by FLA) by using information from the chiller motor nameplate. Set the potentiometer dial at "R16" on the CM-2 board to the calculated LRA/FLA ratio.

85. Affix the warning label (ITEM #070) to the front door of the auxiliary junction box.
86. Repair any damage to the OptiView panel finish with Caribbean Blue touch-up enamel (ITEM #066).
87. Proceed to the appropriate electromechanical starter section that follows for starter wiring. Please note that all starter wiring instructions and diagrams are generalized and may not exactly match the components and wiring installed in the starter cabinet.
88. On the external Analog and Digital Input and Output boards removed EPROM's version 1.06 and install new EPROM's version 1.02. Connect optional Analog and digital inputs and outputs as required for the options on the chiller being retrofitted.
89. Set up DIP Switches as per sheet 3 and 4 of Wiring Diagram for external Analog and digital boards.
90. On digital input and output board reposition fuses and modules as needed to match your chillers options as shown on sheet 3.
91. On the Analog Input/Output Board ensure jumpers are setup as shown on Wiring Diagrams on sheet 4.
92. As shown in figure 57 connect wires as needed for options used for the chiller being retrofitted. See sheets 3 and 4 of wiring diagram for wiring routing and connection details.

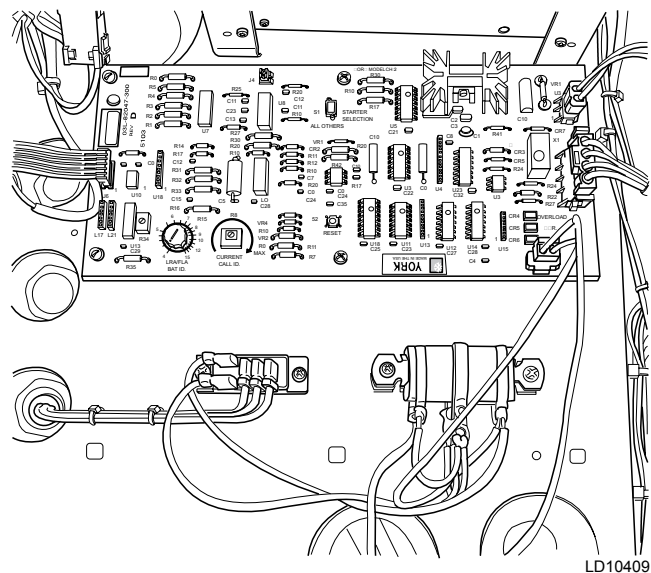
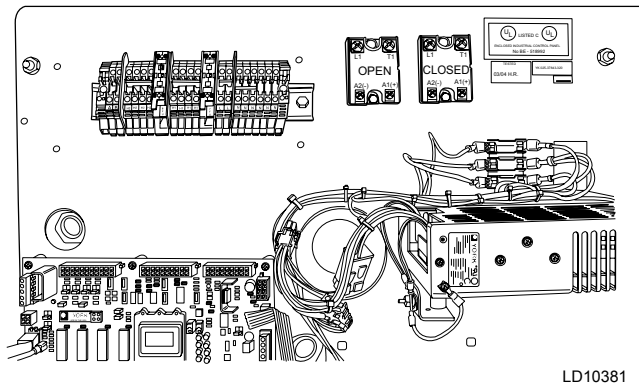

FIGURE 56 - CURRENT MODULE (CM-2) BOARD



LD10381

FIGURE 57 - PRV SOLID STATE RELAYS

GENERAL

Competitive OptiView retrofits for Trane chillers require the Trane tri-state vane actuator (as shown below) in order to interface with the OptiView panel.



LD18187

FIGURE 58 - OPTIVIEW RETROFITS

In mid-2013 Trane stopped supplying the tri-state vane actuator. To continue support of the Trane OptiView retrofits, we've identified and can source a tri-state style actuator. The use of this OEM actuator requires other unit modifications as noted below.

There are two major differences between the Trane tri-state vane actuator and our recommended replacement. First, the Trane actuator contains internal limit switches. The limit switches perform two functions. At the full open vane position the limit switch opens to remove the open signal from the actuator. Without the

limit switch the actuator motor could continue to see voltage at the wide open vane position and eventually burn out. At the closed vane position the limit switch performs the same function while also giving an indication of closed vanes which allows the chiller to start without a load.

The replacement actuator requires the installation of two external limit switches, four relays, four resistors, and a field fabricated bracket. Connection of the vane linkage to the switches must be as noted below. Attachment of the vane linkage further out on the limit switch arm reduces the sensitivity of the switch and will cause issues with the switch incorrectly indicating full open or fully closed vane position. NOTE: Trane models CVHF may require minor grinding of the actuator arm where it fits into the Trane Vane Linkage (clevis) for proper fit.



LD18188

FIGURE 59 - CORRECT PLACEMENT OF LIMIT SWITCHES



LD18189

FIGURE 60 - INCORRECT PLACEMENT OF LIMIT SWITCHES

Wiring of the limit switches is as follows:

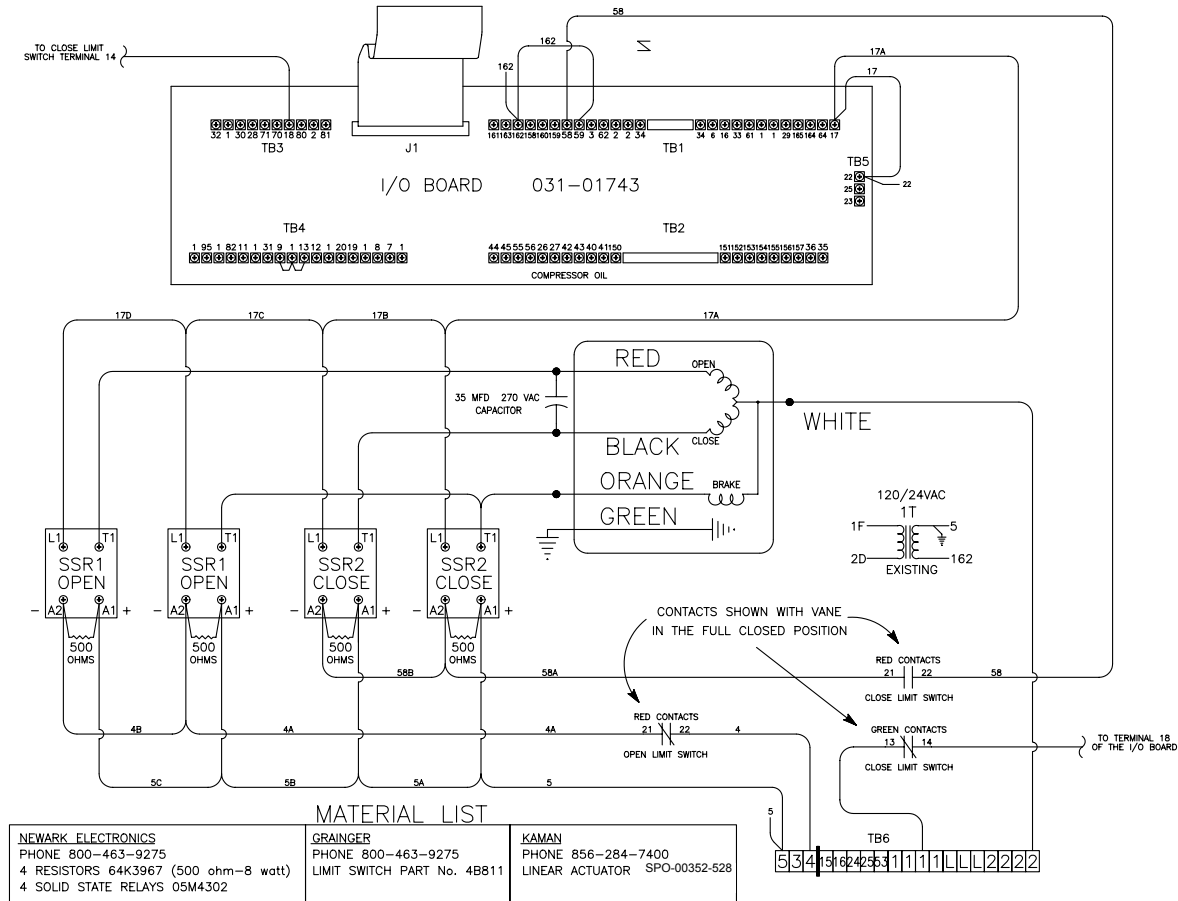

LD18190

FIGURE 61 - TRANE ACTUATOR WIRING SCHEMATIC

The second difference between the Trane and the OEM vane actuator is the speed of the stroke. The Trane actuator has a slower opening and closing speed. To account for this difference, we have made software changes to allow additional adjustment of the load/unload pulse duration.

When replacing an existing Trane tri-state vane actuator on a unit with an OptiView and the 031-02430-000 microboard, you will also need to update the OptiView software to the latest version. The program card part number is 031-03071-001. On units that have an OptiView with a 031-01730-000 microboard, the microboard will need to be replaced with the 2430 microboard (331-02430-701). The 331-02430-701 microboard ships preprogrammed therefore a program card is not required. Reference SI0285 for additional information.

SOFTWARE SETTINGS

For the best and closest control of the leaving chilled water temperature, we recommend the following settings as a starting point for the vane actuator control. In particular, Pulse Time and Pulse Period may need to be fine tuned to provide stable operation. Settings are inputted on the Evaporator Screen.

- Load Rate: 3.00 F/Min
- Sensitivity: 10%
- Pulse Time: 0.1 Sec
- Pulse Period: 2.0 Sec

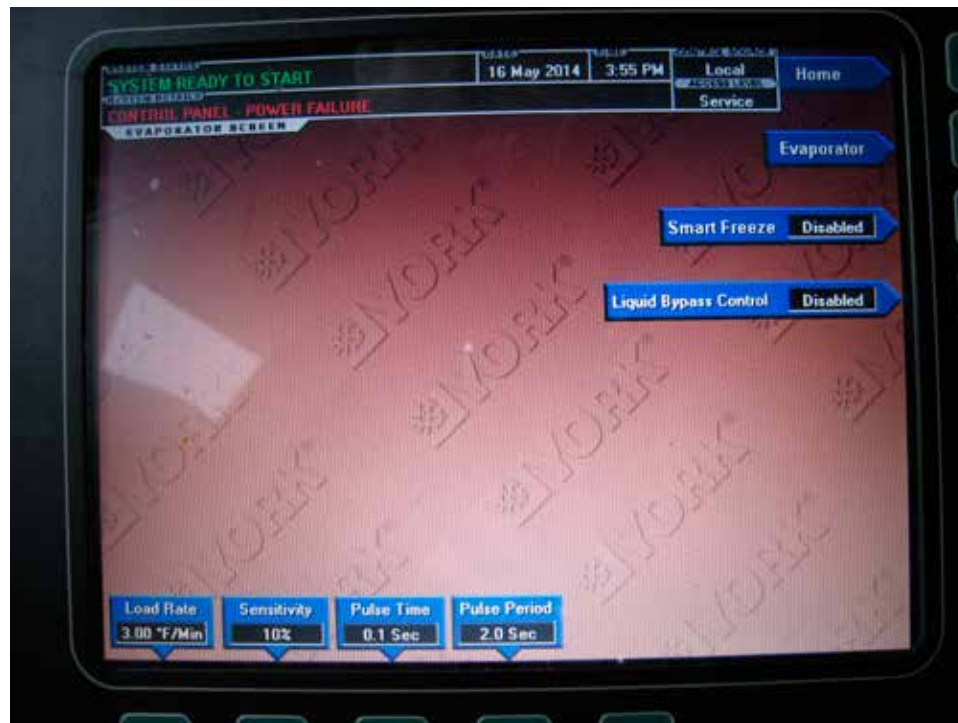

LD18191

INSTALLATION

The Kaman actuator, as received, requires the linkage connection to be rotated 90 degrees for connection to the Trane linkage. To rotate the connection the gear cover must be removed and the connection rotated as shown in the photo below.



LD18233

REQUIRED PARTS

The following parts are required in order to complete the retrofit.

- Vane Actuator
 - Source: Kaman Industrial Technologies, 195 Borrelli Blvd, Suite B, Paulsboro, NJ, 08066, (856) 284-7400
 - Model Number: SPO-00352-528 (Kaman Industrial Technologies)

- Limit Switches (quantity of 2)
 - Source: Grainger
 - Model number: 4B811 (Schneider Electric Limit Switches)
- Solid State Relays (quantity of 4)
 - Source: Newark Electronics, (800) 463-9275
 - Model number: 05M4302
- Resistors (quantity of 4)
 - Source: Newark Electronics, (800) 463-9275
 - Model number: 64K3967 (500 ohm, 8 watt) or one of the following, 38C5602 (500 ohm, 10 watt), 02F1682 (500 ohm, 11 watt), 64K3737 (500 ohm, 12 watt)
- Mounting Bracket (field fabricated)

THIS PAGE INTENTIONALLY LEFT BLANK.

SECTION 3 - WYE-DELTA ELECTROMECHANICAL STARTER

WYE-DELTA STARTER WIRING



Shock Hazard! Due to the extremely high voltage conditions present in the chiller starting components and motor, extreme care should be exercised during installation. Seek assistance from a qualified electrician as necessary.

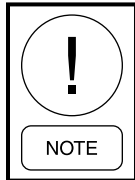

If a starting device other than an electro-mechanical starter (VSD or Solid State) is utilized by the chiller, consult the installation manual for the starter. These instructions are for electromechanical starters only.

1. Locate the original Trane wiring from the starter cabinet to the Trane control unit. This wiring must be reused and relabeled to reflect YORK design. Use preexisting or field-sourced terminal block TB8 in the starter cabinet to keep wiring clean. Refer to Wye-Delta wiring diagram for wiring labels. As required, route additional wires from starter cabinet to the Optiview panel to cutout "C" in the back of the Optiview Control Center. Be sure to include a ground wire for the Optiview cabinet.
2. Pull or Re-Label 5 wires from the Optiview Control Center to the Starter. The wires should be labeled as follows: L, 2, 3, 4 and 24. These wires should land on the corresponding terminal in the Optiview Control Center on TB-6.
3. The five wires from the Optiview Control Center should be terminated on TB 2TB1 as follows: wire L terminates on 2TB1-1, wire #2 terminates on 2TB1-2, wire #24 terminates on 2TB1-24, wire #3 terminates on 2TB1-4 and wire #4 terminates on TB1-3.
4. Mount and Label in Starter cabinet the following devices: TD1 (Grainger Part # 5B385) and CR (Grainger part # 5X847). Use Screws and Din Rail as needed.
5. Remove the following existing devices and wires from starter cabinet. Remove contactor 2K5 and wiring to and from 2K5 coil.
6. Connect wire from 2TB1-24 to the coil terminal of CR.
7. Connect the other coil terminal to 2TB1-2. This replaces the contactor 2K5.
8. Remove wires connected to Terminals #4 and #8 of normally open contact on 2K5. These wires can be discarded.
9. Install jumper from 2TB1-1 to 2TB1-3. Remove the old wire going the wire that is on 2TB1-3 and verify it went to the normally open contact on 2K5 terminal #1.
10. Connect the wire that was connected to 2K5 normally open terminal #1 to one side of the normally open contact on CR.
11. Connect the old wire from the normally open contact of 2K5 terminal #3 to the other side of the normally open contact on CR. Verify this wire is connected to the normally closed Aux-1 on 2K2. Also verify this connects to the normally open Aux-1 contact on 2K3 and normally open Aux-1 contact of 2K1. Run a wire from this same point to the normally open contact of TD1 terminals 1 and 8.
12. Disconnect wires and remove 1U2 from starter. Connect the existing wire #10 that was connected to 1U2 at 1TB2-5 to TD1 coil terminal #2.
13. Run a new wire from TD1 coil terminal 7 to 2TB1-2. The wire #12 that was connected at 1TB2-6 should be rerouted to TD1 Terminals 3 and 6.

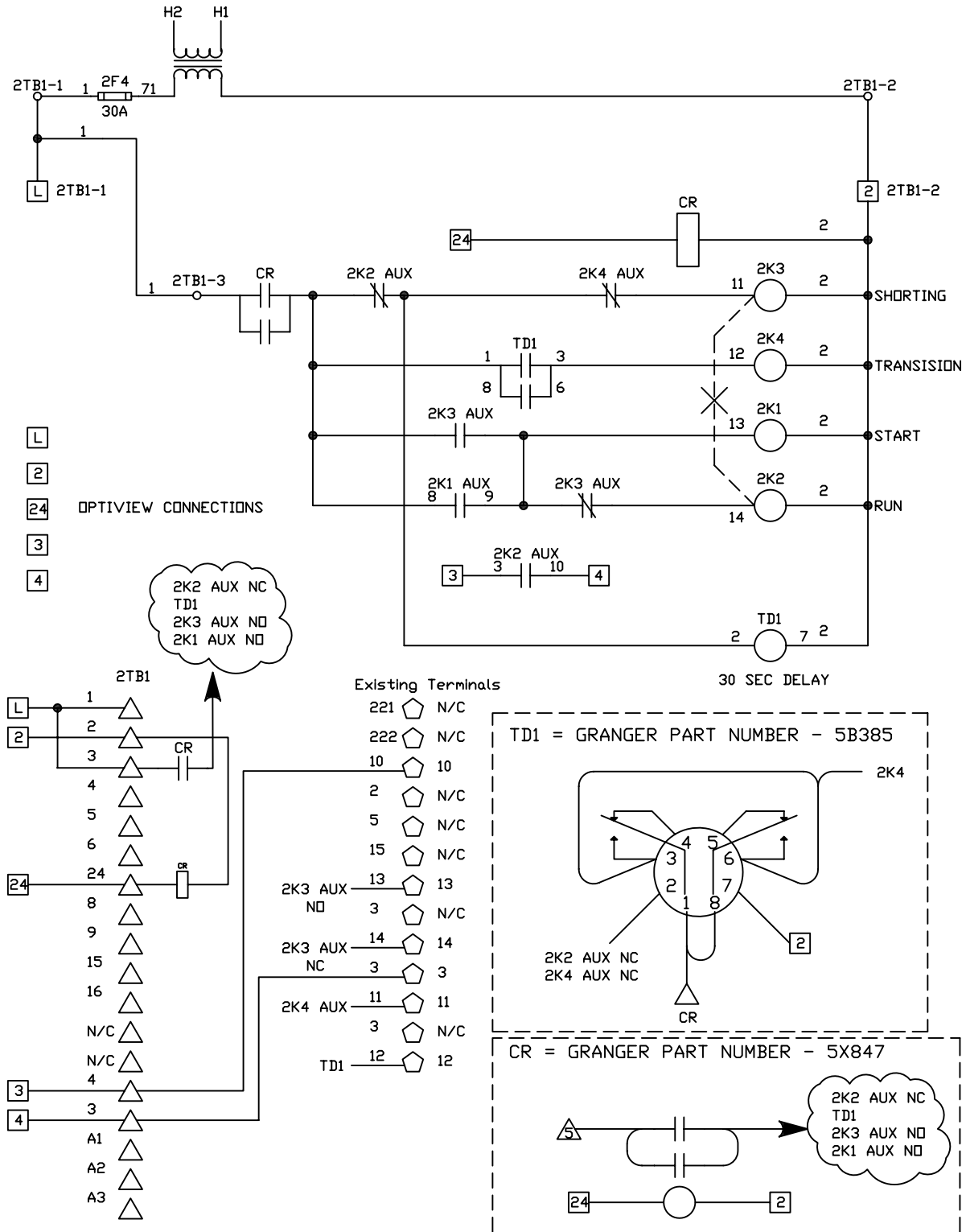

LD19420

FIGURE 62 - TRANE CVHE_CVHF K DESIGN

WYE-DELTA STARTER WIRING



Shock Hazard! Due to the extremely high voltage conditions present in the chiller starting components and motor, extreme care should be exercised during installation. Seek assistance from a qualified electrician as necessary.

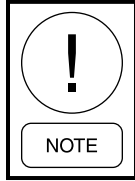

If a starting device other than an electro-mechanical starter (VSD or Solid State) is utilized by the chiller, consult the installation manual for the starter. These instructions are for electromechanical starters only.

1. Ensure you have followed all proper lock out and tag out procedures. Also ensure all test and try procedures have been followed.
2. Locate the original Trane wiring from the starter cabinet to the Trane control unit. This wiring must be reused and relabeled to reflect YORK design. Use preexisting connections in the starter cabinet to keep wiring clean. Refer to Wye-Delta wiring diagram for wiring labels. As required, route additional wires from starter cabinet to the Optiview panel to cutout "C" in the back of the Optiview Control Center. Be sure to include a ground wire for the Optiview cabinet. The following wires need to be routed from the Optiview Control Center to the Starter: L, 2, 3, 4, 29, and 24.
3. Terminate Wire #2 that you ran to the starter from the Optiview Control Center and land it on Terminal 2 on TB6.
4. Leave the Purge Unit circuit connection intact. This comes off of fuse F4.
5. Remove Fuse F3 and disconnect wiring from this fuse. The wiring may be discarded.
6. Disconnect wiring from terminal 13 at the normally open contact of K27.
7. Connect wire 24 from Optiview Control Center to terminal 14 of the normally open contact of K27.
8. Remove wire from terminal 21 on normally open K27 contact. Terminate Wire #29 from Optiview Control Center on this terminal.
9. Remove Wire from F1 to normally open contact K28. If you need to you may cut wire going to normally open contact K28. Connect this cut wire or on Terminal of normally open contacts of K28 the wire #3 from the Optiview Control Center.
10. Remove wire n terminal 22 of normally open contact of K28. Connect wire #4 from Optiview Control Center to terminal 22 from normally open contact of K28.
11. Connect Wire L from Optiview Control Center on Terminal F1.
12. Remove Relay R1 from circuit. Wire one side of normally open contact of K27 to wire previously terminated on terminal XX1 of relay R1 the other wire from normally open contact K27 should be connected to terminal 7 of TD1.
13. Connect terminal #2 of TD1 to wire previously connected to terminal X2 of relay R1.
14. Remove wires from terminals D1 and D2 of R1. Terminate the wire previously on terminal D1 on terminal #1 of TD1.
15. Terminate the wire previously terminated on terminal D2 on terminal #3 of TD1.

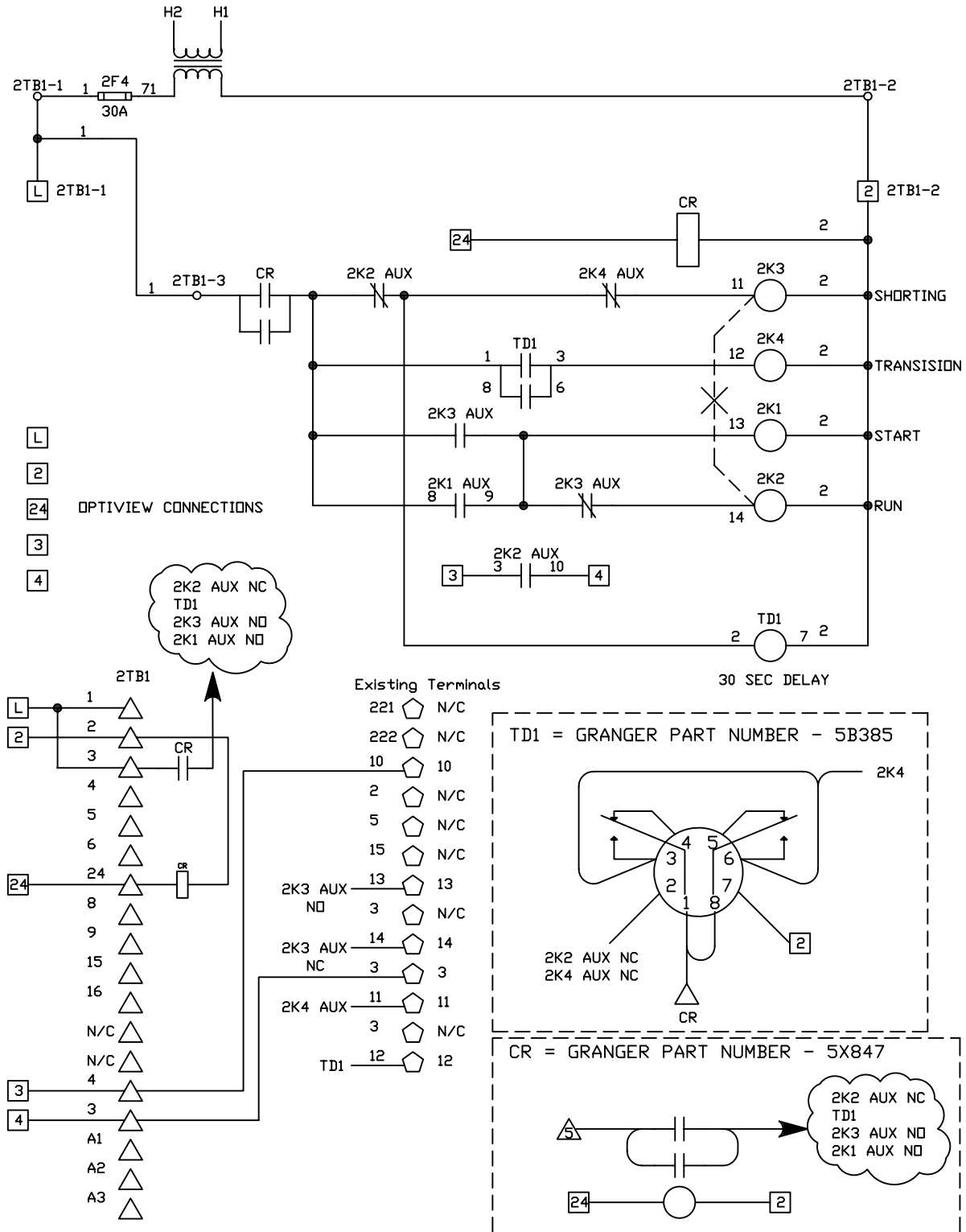

LD19420

FIGURE 63 - TRANE CVHE_CVHF X DESIGN

SECTION 4 - ACROSS-THE-LINE STARTER

ACROSS-THE-LINE STARTER WIRING



Shock Hazard! Due to the extremely high voltage conditions present in the chiller starting components and motor, extreme care should be exercised during installation. Seek assistance from a qualified electrician as necessary.

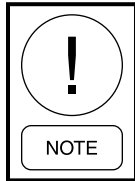

If a starting device other than an electro-mechanical starter (VSD or Solid State) is utilized by the chiller, consult the installation manual for the starter. These instructions are for electromechanical starters only.

1. Identify the original Trane wiring from the starter cabinet to the Trane control unit. This wiring will be reused and must be relabeled to reflect YORK design. Use a pre-existing or field-sourced terminal block (TB8) in the starter cabinet to keep wiring clean. Refer to the Across-The-Line (ATL) starter wiring diagram for wiring labels. As required, route additional wires from the starter cabinet to the OptiView panel. Be sure to include a ground wire for the OptiView cabinet.

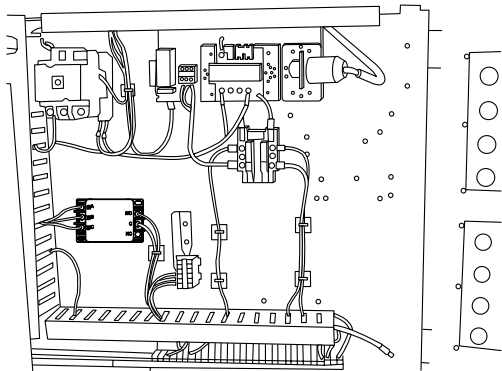

LD10455

FIGURE 64 - ATL STARTER WIRING

2. Remove small-gauge wiring from the main (2K1) contactor and contacts. If equipped, disconnect the 24 VAC transformer in the starter cabinet as this is no longer required.

3. Install the CR1 control relay (ITEM #023,065) in the starter cabinet. Make the following connections to the relay:
 - Connect terminal 2 to “24” on terminal block 8.
 - Connect terminal 4 to “5” on terminal block 8.
 - Connect terminal 3 to the AC input of the main contactor (2K1) four way bridge.
 - Wire terminal 1 to the common wire “2” of the starter 120V transformer.
 - Connect a “short” wire from terminal 5 to terminal 6 of the CR1 control relay.
 - Install a suppressor (ITEM #14) across terminals 1 and 2 of the CR1 relay.
4. Mount the appropriate phase monitor safety device as shown on the high voltage ATL starter wiring diagram (#072, sht. 13). Wire phase monitor common “C” connection to “1” on terminal block 8 and the normally open, “NO”, connection to “53” on terminal block 8.
5. Connect L1, L2, and L3 from the potential transformer (PT) to phase monitor connections A, B, and C, respectively.
6. Locate a normally open contact (Aux-1) on main contactor (2K1) and connect wires for “3” and “4” of terminal block 8 to the contact. This is the full-voltage contact, which will prevent the chiller from being loaded before the motor has reached full power.
7. Route the starter wiring to cutout “C” in the back wall of the OptiView cabinet. Connect the wires from the starter to the appropriate connections in the OptiView Control Center. Proceed to *Section 6 - OPTIVIEW Retrofit Kit Commissioning* at this time.

THIS PAGE INTENTIONALLY LEFT BLANK.

SECTION 5 - OPTIVIEW RETROFIT KIT COMMISSIONING

DESCRIPTION

In order for the OptiView Control Center to work properly, the microboard, I/O boards and software must be properly configured according to the chiller type, refrigerant, chilled liquid, etc. When configuring the OptiView Software, to the *OptiView Control Center Retrofit Kit - Trane Operation Manual (Form 160.10-01)* for a detailed explanation of the OptiView software and each screen function.

The microboard model must be identified and commissioned accordingly.

PRE-COMMISSION

1. Verify that surge suppressors (ITEM #014) have been installed on all relays, solenoid coils, and motor coils that are supplied with power from the OptiView panel. This includes the vent line solenoid, the liquid pumps (as equipped), purge relays, etc.
2. Check all wiring for proper connections, termination, and routing. All wiring must follow national and local code. Make sure wiring for components using shielded cable is not routed near sources of power such as the chiller motors, power cables/leads, etc., as this may cause signal distortion. Use wire ties to bind loose wire together for a cleaner installation.
3. Pressurize and leak test the chiller. Give specific attention to sensors, weld fittings and all lines. Repair any leaks and repeat the test to verify the leaks have been repaired.
4. Evacuate the chiller to manufacturer's standards and replace the compressor oil and refrigerant with the recommended charge.
5. Proceed to *031-2430 Microboard* for commissioning.

031-2430 MICROBOARD

- A. Locate the jumper location for JP16 make sure a jumper is installed. A jumper installed at this location enables communications with an external device at the J13 terminal connection, the COM2 serial port.
- B. Locate jumper JP17. This jumper must be configured for RS-232 interface by placing the jumper on pins 2 and 3.
- C. Locate jumper JP22 on the microboard. Check that there is no jumper installed on the pins. This allows the condenser refrigerant temperature sensor analog input to be properly read by the microboard.
- D. Locate jumpers JP23 and JP24 on the microboard. This configures analog input type for remote devices that control Remote Current Limit Setpoint and Remote Leaving Chilled Liquid Temperature when connected directly to the microboard at J22. If the remote device utilizes 0-10 VDC or 2-10 VDC, the jumpers should not be installed here and allows for this input at J22-1 and J22-3. If the remote device utilizes 0-20mA or 4-20mA, jumpers should be installed at pins 1 and 2 at EACH location to allow for this type of input at J22-2 and J22-4.
- E. Locate the program switches on the 2430 microboard. Verify that switch 1 is in the "OFF" position, which is the position for low pressure chillers.
- F. Program switch 2 allows for chilled liquid selection. Move the switch to the "ON" position if the chilled liquid is brine. The "OFF" position is for water.

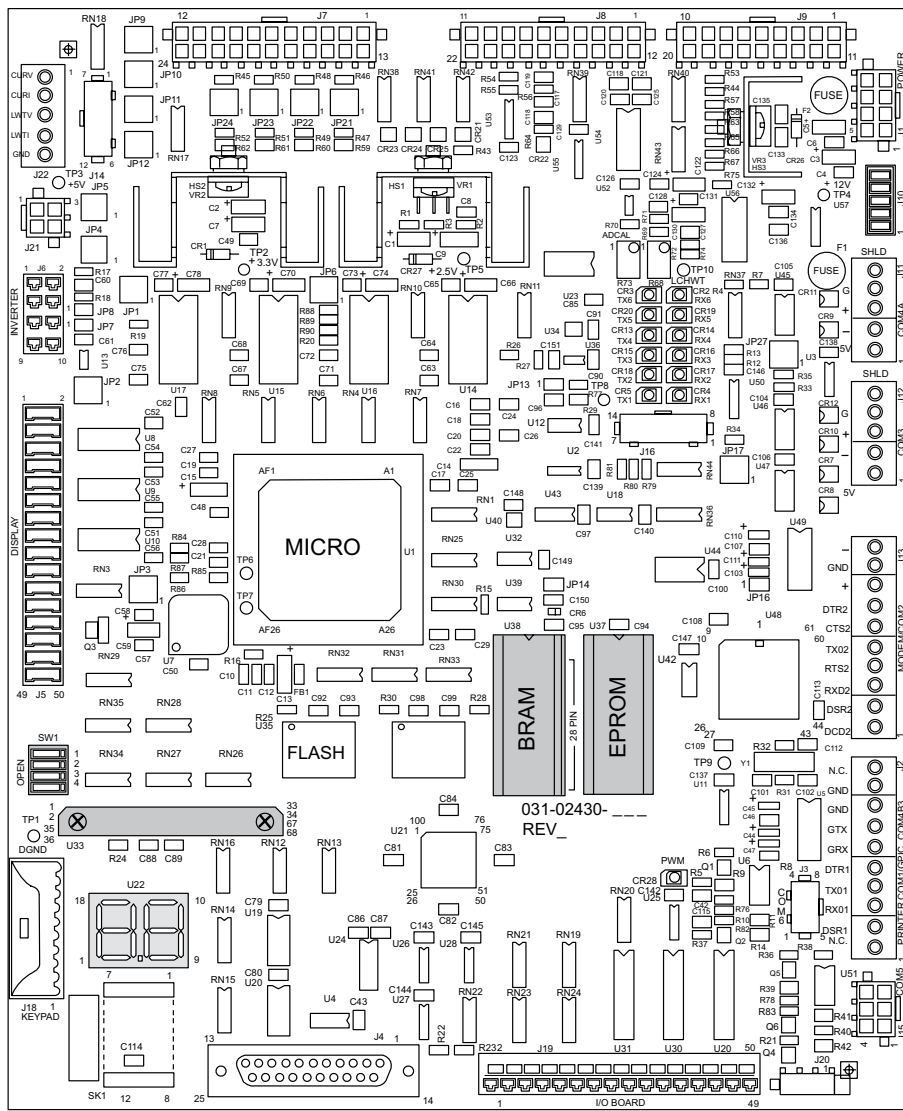

FIGURE 65 - OPTIVIEW 2430 MICROBOARD

INPUT/OUTPUT BOARDS

6. Referring to sheet 4 of the wiring diagram, verify all jumpers (wire and bridge type) on the board are set properly. Make any changes as necessary.
7. Referring to the DIP switch table on digital I/O board drawing, verify the I/O board DIP switches are in the correct position according to the last digit of the part number printed on the I/O board (board #). The correct dip switch setting for each part number is listed on the drawing.

OPTIVIEW SOFTWARE

8. Supply the OptiView Panel with power, watching the display to verify the system software boots properly during startup. Login to the SERVICE access level.
9. View the evaporator, condenser, motor, and oil pump screens to ensure temperature sensors, pressure sensor and other readings register and are correct. Sensors that do not register or are out of range indicate wiring connection problems, incorrect sensor, or damage. Data Display Mode (English or Metric Units of Measurement) can be set in the User screen, which can be accessed from the Setup screen

Evaporator Screen

10. Navigate to the Evaporator screen. Adjust the leaving chilled water temperature, range, shut-down, restart, and brine low pressure cutout (if brine is used) setpoints to the desired settings.
11. Enable the evaporator refrigerant temperature sensor and select operation of the “Smart Freeze” (on or off). Set the initial sensitivity level to 10%.

Load Rate Screen

12. Navigate to the Load Rate screen from the Evaporator screen and adjust the load rate setting to an initial setting of 3.00 °F/min (1.7 °C/min).

Condenser Screen/Purge

13. Navigate to the Condenser screen and enable the drop leg and condenser refrigerant temperature sensors (as equipped). Adjust the high pressure warning threshold to the desired setpoint.
14. Set the type of purge utilized by the chiller. If a Trane purge is utilized, set the type of purge to “Skyguard Remote”. If the Turboguard II is used, set the type as such and enter the Purge screen to enable “high efficiency”, as equipped. Adjust the maximum purge to the desired setpoint.

Compressor Screen

15. Navigate to the Compressor screen and set the vent line off state to “energized”. Verify that the labyrinth solenoid (not applicable to Trane) is “disabled” and the Pre-rotation vanes control is set to “Auto”.

Oil Sump Screen

16. Navigate to the Oil Sump screen and adjust the low pressure limit to the desired setpoint. This is the limit at which the oil pressure can drop to before the chiller will do a safety shutdown. Use the low oil pressure limit recorded from the original Trane control.
17. Adjust the differential oil pressure safety switch, located in the small junction box, to one (1) PSID below the low pressure limit setpoint.
18. Set the chiller prelube and coastdown times. The recommended minimum prelube time is 30 seconds. Adjust the oil heater setpoint to the desired temperature; the default is 140° F (60° C).

Motor Screen

19. Navigate to the Motor screen. For electromechanical starters, set the current limit and pulldown limit to 100% in the motor screen. These settings can be changed after starter calibration/setup has been verified. Adjust the pulldown demand time to the desired setpoint. For solid state starter and VSD applications, to the *OptiView Control Center Retrofit Kit - Trane Service Manual (Form 160.10-MI)* for additional setpoints and calibration.

Motor Temperature Screen

20. From the Motor screen, enter the Motor Temperature screen. Set the winding sensor mode as required to read signals from the motor RTD module and/or thermal switches. Set the winding temperature cutout to the desired temperature. Any of the phase windings that reach this temperature setpoint will cause a chiller shutdown to be performed. Select “Sensor 1” for phase A, B, and C.

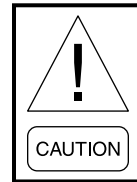

YORK does NOT recommend operating the chiller while motor winding and bearing sensors are disconnected or inoperative. Extensive damage to the chiller as well as physical injury may result in the event the chiller motor malfunctions and overheats.

21. Observe the winding temperatures, all three sensors should indicate similar temperatures. A sensor with an out of range reading or a reading which is not comparable to other sensors indicates a malfunctioning sensor(s). Voltage output for these sensors can be viewed on the analog diagnostic screen of the OptiView Panel. Compare the voltage output from each of the motor winding sensors to what is listed in Appendix “A”. As the compressor motor will not be warm, measured voltage will be comparable to voltage at ambient (room) temperature. If a phase winding sensor is malfunctioning and cannot be repaired, the sensor for that phase can be disabled. The motor must be repaired or replaced when all sensors are malfunctioning or inoperative.

22. Enable the bearing temperature sensors, as equipped, in the Motor temperature screen. Set the bearing sensor mode to analog-type sensors. Once the sensors are enabled and the mode is selected, temperature readings will be displayed on the OptiView screen. A reading that is out of range indicates a possible wiring connection problem or a damaged sensor.
23. Adjust the bearing temperature cutout setpoint. If either bearing temperature reaches this setpoint, a chiller shutdown will be performed.
24. If the chiller motor is equipped with a motor cooling pump, select enabled and be sure the cooling pump mode is set to automatic operation.

Setpoints Screen

25. Navigate to the Setpoints screen and verify all displayed settings are correct. Set the remote analog input range to the proper level, as equipped.

Setup Screen

26. Move to the Setup screen. Verify that all displayed settings are correct. Enable the clock and adjust the date and time, selecting the type of clock desired (12 or 24 hour). For 2430 boards, enable anti-recycle, and set power failure restart, chilled liquid pump operation, and motor type as desired.

User Screen

27. Specific users and passwords can be programmed at the User screen, as desired.

Operations Screen

28. Navigate to the Operations screen from the setup screen. Set the control source, chiller model, and refrigerant type to the proper selections.
29. Enable or disable hot gas bypass and refrigerant level control, as equipped.
30. The chiller operating hours and number of starts can be programmed at this screen using the “TEST OP” or “ADMIN” access level. The “TEST OP” level is accessed by entering “0228” at the login access level prompt.

The “ADMIN” password is time sensitive and changes daily. This password is generally used to modify sales order information and is only available by calling YORK Service.

Schedule Screen

31. Navigate to the Schedule screen. If so desired, a schedule can be set up to automatically control chiller operation during the weekdays, nights and weekends. Refer to the explanation of the Schedule screen in *OptiView Control Center Retrofit Kit - Trane Operation Manual (Form 160.10-O1)* for schedule setup.

Comms Screen

32. If applicable, setup printer communications (baud rate, data bits, parity, and stop bits) according to the printer manufacturer’s specifications.
33. If the chiller is a part of a multiple chiller ISN network, the chiller ID can be programmed for identification on reports.

Printer Screen

34. Access the printer screen. Select the manufacturer of the printer from the “printer type” setting, as equipped.
35. If automatic printer logging is desired, this feature must be enabled. Set the printer log start time and output interval at desired settings. ACC auto map print can be enabled or disabled here as well.

Sales Order Screen

36. Navigate the sales order screen and press the “Set Order Info” to input the commissioning date, the given job name and location, and other specific chiller information.

History Screen

37. Accessing the history screen allows the custom view to be setup, which will enable the operator to display user selected chiller operating information while the chiller is running.

Trending set up may also be accessed from the History screen, which will show the selected parameters in graph form. Refer to the explanation of the Trending Setup screen in *OptiView Control Center Retrofit Kit - Trane Operation Manual (Form 160.10-O1)* for setup of the trending feature.

STARTER/MOTOR TESTING



Shock Hazard! Exercise extreme care during starter testing, as extremely high voltage conditions are present in the starter cabinet. While working with the starter, Lock-Out / Tag-Out the starter power source.

38. Once all setpoints have been entered and verified in the OptiView software, a dry run of the chiller starter can be performed. to the applicable starter.

Wye-Delta Electromechanical Starter

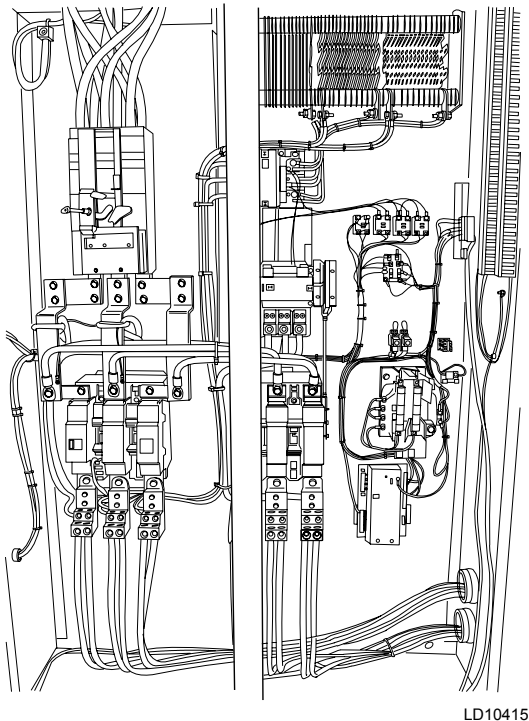

FIGURE 66 - WYE-DELTA STARTER EXAMPLE

- A. Lock-out and tag-out the starter power source. Disconnect the 4, 5, and 6 motor power leads from the run contactor in the motor starter box. These leads **MUST** be individually insulated!
- B. Return the power supply to the starter and OptiView panel. Power up the OptiView panel, making sure there are no problems during or after system boot-up. The starter contactor sequence must be verified to ensure that starter will operate the compressor motor properly.
- C. Place the compressor motor switch in the “START-RUN” position. The OptiView software will begin the chiller start sequence, attempting to start the chiller compressor motor. Once the system is

done with prelube, the “RUN” signal will be supplied to the starter.

- D. The starter controls will supply power to the shorting contactor (2K3). While power is supplied to the shorting contactor, the main contactor (2K1) will be supplied with power. Once the main contactor is supplied with power, the resistor contactor (2K4) will be energized and the shorting contactor will be de-energized. As the shorting contactor is de-energized, the run contactor (2K2) will be energized. Shortly after the run contactor is energized, the resistor contactor will become de-energized.
- E. This procedure should be completed before the OptiView panel recognizes that no voltage is actually present at the starter (approximately 25 sec.). Make sure that the mechanical linkage between 2K2 and 2K3 is adjusted and operates properly during the motor startup sequence. This linkage ensures the 2K2 and 2K3 are never energized at the same time.
- F. Lock-out and tag-out power to the OptiView panel and the starter. Re-connect the motor leads.

Proceed to *Motor Rotation Test*.

Autotransformer Electromechanical Starter

- A. Lock-out and tag-out the starter power source. Open the starter cabinet and locate the starter 120 VAC transformer. Remove the fuses from the transformer. The fuses **MUST** be removed from the transformer, otherwise deadly electrical current will be present! Some starters may be equipped with a 120V power test receptacle that allows the starter to be tested without the presence of high voltage current. Apply a source of 120 volt power to the test receptacle.
- B. Remove the transformer fuses from starters not equipped with a test receptacle. Connect a source of 120 volt power to the low side of the starter transformer to allow the starter operation to be tested.
- C. Place the compressor motor switch in the “START-RUN” position. The OptiView software will begin the chiller start sequence, attempting to start the chiller compressor motor. After system prelube, voltage will be supplied to the starter. The starter contactor sequence must be verified to ensure that starter will operate the compressor motor properly.

- D. The OptiView will first supply power to the main contactor (2K1). Once power is supplied to the main contactor, the autotransformer contactor (2K3) will be powered. This ensures that power to the main contactor will not be dropped and the autotransformer contactor will then be de-energized. As soon as the autotransformer contactor is de-energized, the run contactor (2K2) will be energized.
- E. This procedure should be completed before the OptiView panel recognizes that no voltage is actually present at the starter (approximately 25 sec.). Make sure that the mechanical linkage between 2K2 and 2K3 is adjusted and operates properly during the motor startup sequence. This linkage ensures that 2K2 and 2K3 are never energized at the same time.
- F. Once the contactor sequence is verified, lockout starter power and replace the transformer fuses.
- G. Adjust the initial failure level setting on the starter phase monitor to 8-10 % below the phase monitor input voltage.
- H. For example: If the input is 120 VAC (phase monitor part B158B), the failure level should be set at approximately 95 VAC. As the adjustment range is 85 to 125 VAC, 95 VAC correlates to approximately the 10 o'clock position on the failure level adjustment screw. This setpoint can be fine tuned after the chiller is operating.

Proceed to *Motor Rotation Test*.

Across-The-Line Electromechanical Starter

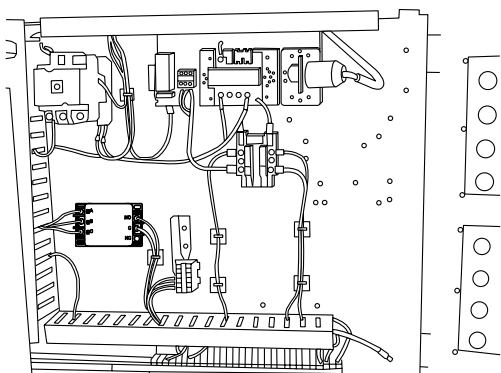

LD10455

FIGURE 67 - ATL STARTER EXAMPLE

- A. Lock-out and tag-out the starter power source. Open the starter cabinet and locate the starter 120 VAC transformer. Remove the fuses from the transformer. The fuses **MUST** be removed from the transformer, otherwise deadly electrical current will be present! Some starters may be equipped with a 120V power test receptacle that allows the starter to be tested without the presence of high voltage current. Apply a source of 120 volt power to the test receptacle.

If the starter is not equipped with a test receptacle, be sure the fuses are removed from the starter transformer. Connect a source of 120 volt power to the low side of the starter transformer. This will supply power to the OptiView panel and allow the starter operation to be tested.

- B. Place the compressor motor switch in the "START-RUN" position. The OptiView software will begin the chiller start sequence, attempting to start the chiller compressor motor. After system prelube, voltage will be supplied to the starter. The starter contactor sequence must be verified to ensure that starter will operate the compressor motor properly.
- C. The OptiView will supply power (run signal) to the CR1 control relay through the "24" wire. This will close the relay contacts supplying the main contactor (2K1) four-way bridge with current. Once power is supplied to the main contactor, the contactor will come in, signifying power will be supplied to the motor.

The CR1 control relay and main contactor will be energized as long as the run signal is being received from the OptiView panel.

- D. Once the contactor sequence is verified, lockout starter power and replace the transformer fuses.
- E. Adjust the initial failure level setting on the starter phase monitor to 8-10 % below the phase monitor input voltage.

For example, if the input is 120 VAC (phase monitor part B158B), the failure level should be set at approximately 95 VAC. As the adjustment range is 85 to 125 VAC or 40 volts total adjustment, 95 VAC correlates to approximately the ten o'clock position on the failure level adjustment screw. This setpoint can be fine tuned after the chiller is operating.

Proceed to *Motor Rotation Test*.

MOTOR ROTATION TEST

39. Once the proper starter contactor sequence has been verified, switch the OptiView panel switch to the “OFF” position and LOCK-OUT and tag-out power to the starter and OptiView panel. Reconnect any components disconnected for testing.

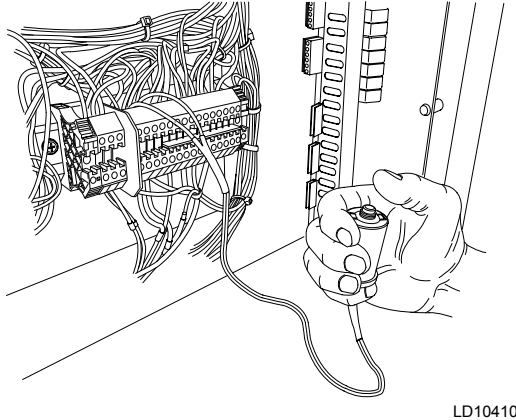
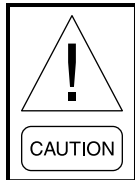

FIGURE 68 - MOMENTARY JOG SWITCH

40. To ensure that the motor leads and wiring are connected for proper motor rotation, the motor can be jogged by temporarily connecting a momentary switch between terminal 24, terminal block 5 (TB5-24) and terminal 25, terminal block 5 (TB5-25) on the I/O board. The wire from the low oil pressure cutout switch at TB5-24 must be disconnected prior to performing the test. The momentary switch must have a minimum contact rating of 2 FLA, 10 LRA at 115 volts, AC. to sheet 2 of the kit wiring diagram to enclose these connections.
41. Reconnect the power supply to the motor, making sure all wires have been properly reconnected and taking all safety precautions. Apply power to the OptiView panel
42. After the OptiView software has booted, turn the compressor switch to the “START/RUN” position and allow the system prelube to start.



DO NOT allow the compressor motor to rotate in the wrong direction! Stop the motor immediately if improper rotation occurs.

43. During system prelube, close the momentary switch installed between the CM-2 and I/O boards. This will allow the compressor motor to rotate once prelube has finished. Observe the rotation of the compressor motor, making sure the

motor is rotating in the proper direction. Immediately release the momentary switch once motor rotation is verified.

44. If the motor rotates in the wrong direction, check the motor leads for correct installation.

CURRENT MODULE (CM-2) CALIBRATION

45. Lockout and tag-out the OptiView and starter power supply. Remove the momentary switch installed between the CM-2 and I/O boards and reconnect the wire from the low oil pressure cutout switch to TB5-24.
46. Reconnect the OptiView power supply. Perform a final inspection of the chiller electrical and mechanical systems.
47. Once the final check has been completed, move the OptiView compressor switch to the START/RUN position and allow the chiller to begin running.
48. When the chiller has started and is running, check all screens for proper temperature, pressure, and motor readings. Should the OptiView panel recognize any problems during startup or while running, the display will alert the operator to any of these problems by indicating the problem on the display and shutting down accordingly. Any indicated problems should be remedied before proceeding.



Shock Hazard! Extremely high voltage conditions are present at the chiller starting components and motor, extreme care should be exercised during calibration. While working with the starter or motor, LOCK-OUT and tag-out the starter power source.

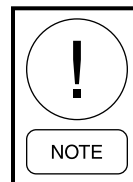

Do not use the OptiView display to determine when the chiller is at full load. The OptiView full load amps display must be calibrated.

49. Run the chiller to full 100% load to allow CM-2 board calibration. Use a remote type clamp-on meter on a motor lead to measure load on starters not equipped with an ammeter.

To load the chiller, the pre-rotation vanes can be manually operated, load rate can be increased, the chilled liquid temperature can be lowered and the

condenser water temperature raised. The chiller must be running under full load before proceeding.

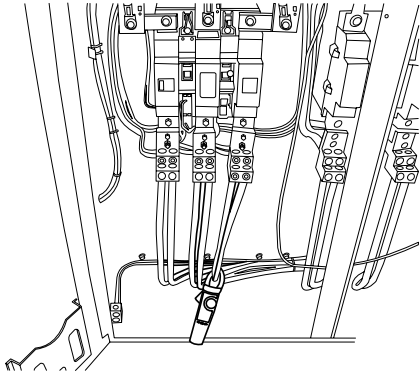

LD10452

FIGURE 69 - CLAMP-ON AMMETER

50. Check the voltage reading across the J1-1 and J1-2 connector terminals of the CM-2 board. If the slide resistors are adjusted properly, the voltage between these terminals should be 0.90 - 1.05 VDC. Adjust the slide resistors if the voltage is incorrect.
51. With the chiller motor running at full load amps (FLA), calculate 105% of FLA and increase chiller load to this value, as indicated by the ammeter. Adjust the current calibration screw (R8) until the 105% LED (CR6) illuminates. Reduce chiller operation to 100% full load amps.
52. When the chiller is running at 100% of FLA (as indicated by the ammeter), adjust the potentiometer screw at R34 on the CM-2 board so the display on the OptiView panel reads 100% FLA.

53. Return the pre-rotation vanes to automatic control and re-program or adjust any setpoints manipulated to acquire full load on the chiller.
54. The phase monitor failure level may need to be fine-tuned for depending on the integrity of the starter power source (as equipped). Adjust the failure level as required. to the phase monitor instructions if necessary.
55. Program any remaining setpoints in the OptiView panel as necessary. Refer to the *OptiView Control Center Retrofit Kit - Trane Operation Manual (Form 160.10-01)* for detailed screen and setpoint explanations.
56. Affix the service rating plate from the Trane control unit to the right outside wall of the OptiView cabinet.

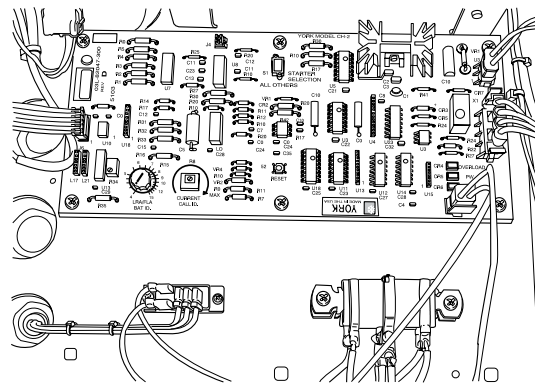

SECTION 6 - LIQUID BY-PASS

LIQUID BY-PASS OPERATION

Screen Display Values

1. Evaporator Saturation Temperature (EST)
2. Leaving Chilled Liquid Temperature (LCHWT)
3. Evaporator Approach Temperature (LCHWT-EST)
4. Evaporator Approach Setpoint (2° to 10° Degrees) 1/10 degree resolution – Default 3°
5. Open pulse time to open bypass valve (1 to 5 sec) 1 second resolution – Default 5 Sec
6. Open Wait value time between open pulses (1 to 10 sec) 1 second resolution – Default 5 Sec
7. Close pulse time to close bypass valve (1 to 5 sec) 1 second resolution – Default 3 Sec
8. Close Wait value time between close pulses (1 to 10 sec) 1 second resolution – Default 5 Sec
9. Approach Dead Band (1° to 5° Degrees) 1/10 degree resolution – Default 1°
10. Auto – Manual liquid valve control (service mode only) Screen with Open button Close button
11. Change setpoint button (service mode only)

OPERATION

When the “Evaporator Approach Temperature” increases to .1 of a degree above the “Evaporator Approach Setpoint” value the bypass valves will begin to pulse open at the “Open Pulse” time

“Open Wait” is the time between open pulses.

The open pulses continue until the “Evaporator Approach Temperature” rises above the

“Evaporator Approach Setpoint” value.

The close pulses will begin to close the bypass valve when the “Evaporator Approach Temperature” rises above “Evaporator Approach Setpoint” plus the “Approach Dead Band” value

“Close Wait” is the time between close pulses.

If at any time during chillers operation the liquid valve has been commanded to open, then when the chiller is turned off, the liquid valve should be driven closed for 2 minute.

INSTALLATION

In order to accomplish this, the installing Technician will need to weld pipe to the existing liquid flange on the chiller as shown in Figure 71.

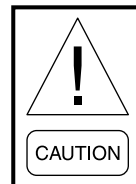

Do not weld to the vessel itself as this could require additional costs and expenses.



FIGURE 71 - LIQUID/ORIFICE BYPASS EXAMPLE

It is important to install isolation valve on both sides of the by-pass control valve. This is generally done at the connections on both ends. See figure 72.



FIGURE 72 - LIQUID/ORIFICE BYPASS EXAMPLE

The Liquid By-Pass installation is a field fabricated assembly.

WIRING

The wiring of the liquid by-pass actuator is shown on wiring diagram 035-18611-000 sheet 11.

SECTION 7 - MOTOR COOLING

MOTOR COOLING

Screen Display Values

1. Motor Wing Temperatures Phase A, B, C Sensors 1 and 2 for each phase.
2. Motor Cooling Pump Mode in Auto.
3. Motor Cooling Pump Setpoint. Range 2000 to 2500 . Default is 2250 .
4. Minimum Run Time Limit. In Minutes.
5. Motor Winding Cutout.

OPERATION

There are six motor temperature sensors available A1-A2, B1-B2, C1-C2. The highest one of the sensors that is enabled would be used to enable an output 8 on the Frick digital board. This output would be used to start a liquid pump to provide refrigerant to cool the motor windings.

INSTALLATION

In order to accomplish this, the installing technician will need to cut and braze pipe as shown in Figure 73.



FIGURE 73 - REFRIGERANT PUMP

It is important to install isolation valve on both sides of the pump. See figure 73.

WIRING

The wiring of the liquid by-pass actuator is shown on wiring diagram 035-18611-000 sheet 3.

THIS PAGE INTENTIONALLY LEFT BLANK.

APPENDIX A - ANALOG MOTOR WINDING SENSOR DATA

TABLE 9 - ANALOG MOTOR WINDING/BEARING SENSOR DATA

ACTUAL TEMPERATURE		SENSOR VOLTAGE (± 0.05 VOLTS)	NOMINAL RESISTANCE (OHMS)	ACCEPTABLE RESISTANCE VALUES (OHMS)	
°F	°C			MINIMUM	MAXIMUM
50	10	0.321	70.1 ± 2.7	67.4	72.8
55	13	0.326	71.1 ± 2.7	68.4	73.8
60	16	0.330	72.1 ± 2.7	69.4	74.8
65	18	0.334	73.1 ± 2.7	70.4	75.8
70	21	0.338	74.0 ± 2.6	71.4	76.6
75	24	0.342	75.0 ± 2.6	72.4	77.6
80	27	0.347	76.0 ± 2.6	73.4	78.6
85	29	0.351	77.0 ± 2.6	74.4	79.6
90	32	0.355	78.0 ± 2.6	75.4	80.6
95	35	0.359	79.0 ± 2.6	76.4	81.6
100	38	0.364	80.0 ± 2.6	77.4	82.6
110	43	0.372	82.0 ± 2.5	79.5	84.5
120	49	0.381	84.0 ± 2.5	81.5	86.5
130	54	0.390	86.0 ± 2.5	83.5	88.5
140	60	0.397	88.0 ± 2.5	85.5	90.5
150	66	0.407	90.2 ± 2.4	87.8	92.6
160	71	0.415	92.2 ± 2.4	89.8	94.6
170	77	0.424	94.3 ± 2.3	92.0	96.6
180	82	0.433	96.5 ± 2.3	94.2	98.8
190	88	0.441	98.5 ± 2.3	96.2	100.8
200	93	0.450	100.8 ± 2.3	98.5	103.1
210	99	0.459	103.0 ± 2.2	100.8	105.2
220	104	0.468	105.1 ± 2.2	102.9	107.3
230	110	0.476	107.2 ± 2.1	105.1	109.3
240	116	0.486	109.5 ± 2.0	107.5	111.5
250	121	0.494	111.6 ± 2.0	109.6	113.6
260	127	0.504	114.0 ± 2.0	112.0	116.0
270	132	0.514	116.4 ± 2.1	114.3	118.5
280	138	0.523	118.7 ± 2.2	116.5	120.9
290	143	0.532	121.1 ± 2.2	118.9	123.3
300	149	0.542	123.6 ± 2.3	121.3	125.9
310	154	0.552	126.1 ± 2.3	123.8	128.4

*Overall accuracy of the motor winding temperature thermistors is ± 15°F (± 8°C).

A

THIS PAGE INTENTIONALLY LEFT BLANK.

APPENDIX B - ANALOG SENSOR INPUT RANGES

The following table indicates the valid display range for each of the analog sensor input parameters for low pressure chillers. In the event that the input sensor is reading a value outside of these ranges, the less than (<) or greater than (>) symbols will be displayed beside the minimum or maximum value, respectively.

TABLE 10 - ANALOG SENSOR INPUT RANGES

ANALOG INPUT	ENGLISH RANGE			METRIC RANGE		
	LOW	HIGH	UNITS	LOW	HIGH	UNITS
Leaving Chilled Liquid Temperature (RT1)	0.0	82.0	°F	-17.7	27.7	°C
Return Chilled Liquid Temperature (RT9)	0.0	94.1	°F	-17.7	34.5	°C
Leaving Condenser Liquid Temperature (RT4)	8.0	133.5	°F	-13.3	56.3	°C
Return Condenser Liquid Temperature (RT5)	8.0	133.5	°F	-13.3	56.3	°C
Evaporator Refrigerant Temperature (RT7)	0.0	126.1	°F	-17.7	52.3	°C
Discharge Temperature (RT2)	19.0	226.3	°F	-7.2	107.9	°C
Oil Temperature (RT3)	19.0	226.3	°F	-7.2	107.9	°C
Condenser Pressure (CPT)	2.5	35.3	PSIA	17.2	243.4	KPAA
Condenser Temperature (R11)* (RT17)	-1.4	124.2	°F	-18.5	51.2	°C
Condenser Temperature (R123)* (RT17)	7.2	130.1	°F	-13.7	54.5	°C
Evaporator Pressure (EPT)	0.0	12.5	PSIA	6.9	86.2	KPAA
Evaporator Temperature (R11)* (RT7)	-31.2	66.8	°F	-35.7	19.3	°C
Evaporator Temperature (R123)* (RT7)	-22.4	74.2	°F	-30.2	23.4	°C
Oil Sump Pressure (LOP)	2.9	20.9	PSIA	20.0	144.1	KPAA
Oil Pump Pressure (HOP)	14.3	78.2	PSIA	98.6	539.2	KPAA
Purge Pressure (PPT)	0.0	100.0	PSIA	6.9	689.5	KPAA
Drop Leg Refrigerant Temperature (RT6)	0.0	121.8	°F	-17.7	49.8	°C
Bearing Temperature (RT15, RT16)	30.0	250.0	°F	-1.1	121.1	°C
Refrigerant Level (Future)	0.0	100.0	%	0.0	100.0	%

*Calculated values when represented as a saturation temperature. They will display XXX if the pressure used for the calculation is out of range.

B

THIS PAGE INTENTIONALLY LEFT BLANK.

APPENDIX C - PROGRAMMABLE SETPOINT VALUES

TABLE 11 - PROGRAMMABLE SETPOINT VALUES

EVAPORATOR SCREEN				
SETPOINT	ACCESS LEVEL	MINIMUM VALUE	MAXIMUM VALUE	DEFAULT
Local Leaving Chilled Liquid Temperature - Setpoint	Operator	38.0 °F - Water 36.0 °F - Sm Frz 10.0 °F - Brine	70.0 °F	45.0 °F
Local Leaving Chilled Liquid Temperature - Range	Operator	10.0 °F	20.0 °F	10.0 °F
LChLT Cycling Offset - Shutdown	Operator	1.0°F	Varies with LChLT setpoint and chilled liquid type.	4.0 °F or highest allowed value, whichever is lower.
LChLT Cycling Offset - Restart	Operator	0.0 °F	Varies with LChLT setpoint and chilled liquid type.	0.0 °F
Brine Low Evaporator Cutout	Service	0 PSIA	12.5 PSIA	12.5 PSIA
Sensitivity	Service	10 %	200 %	100 %
Smart Freeze	Service	Off	On	Off
Refrigerant (Sensor)	Service	Disabled	Enabled	Disabled

LOAD RATE SCREEN (EVAPORATOR SUBSCREEN)				
SETPOINT	ACCESS LEVEL	MINIMUM VALUE	MAXIMUM VALUE	DEFAULT
Load Rate	Service	0.38 °F / Min, 0.75°F / Min, 1.13 °F / Min, 1.50 °F / Min, 2.25 °F / Min, 3.00°F / Min, 5.25°F / Min, 10.50 °F / Min		0.38 °F / Min

CONDENSER SCREEN				
SETPOINT	ACCESS LEVEL	MINIMUM VALUE	MAXIMUM VALUE	DEFAULT
High Pressure Warning Threshold	Service	14.0 PSIA	28.8 PSIA	28.8 PSIA
Drop Leg (Sensor)	Service	Disabled	Enabled	Disabled
Refrigerant (Sensor)	Service	Disabled	Enabled	Disabled
Purge Type	Service	TurboGuard, SkyGuard Local, SkyGuard Remote		SkyGuard Remote

PURGE SCREEN (CONDENSER SUBSCREEN)				
SETPOINT	ACCESS LEVEL	MINIMUM VALUE	MAXIMUM VALUE	DEFAULT
High Efficiency Purge System	Service	Disabled	Enabled	Disabled
Maximum Purges / Hour	Operator	10	30	20
Maximum Purges / Hour	Service	1	30	20

C

TABLE 11 - PROGRAMMABLE SETPOINT VALUES (CONT'D)

COMPRESSOR SCREEN				
SETPOINT	ACCESS LEVEL	MINIMUM VALUE	MAXIMUM VALUE	DEFAULT
Vent Line Off State	Service	De-Energized	Energized	De-Energized

HOT GAS BYPASS SCREEN (COMPRESSOR SUBSCREEN)				
SETPOINT	ACCESS LEVEL	MINIMUM VALUE	MAXIMUM VALUE	DEFAULT
Close Percentage	Service	5 %	15 %	5 %
Hold Period	Service	30 Min	120 Min	30 Min
Surge Sensitivity	Service	0.1	1.3	0.3
Minimum Load	Service	0 °F	4 °F	0° F

VSD CALIBRATION SCREEN (COMPRESSOR SUBSCREEN)				
SETPOINT	ACCESS LEVEL	MINIMUM VALUE	MAXIMUM VALUE	DEFAULT
Increment Amount	Service	0.1 Hz	10.0 Hz	1.0 Hz

SURGE PROTECTION SCREEN (COMPRESSOR SUBSCREEN)				
SETPOINT	ACCESS LEVEL	MINIMUM VALUE	MAXIMUM VALUE	DEFAULT
Shutdown	Service	Disabled	Enabled	Enabled
Extended Run	Service	Disabled	Enabled	Disabled
Count Window	Service	1 Min	5 Min	3 Min
Count Limit	Service	4	20	15
Surge Sensitivity	Service	0.3	1.3	0.3

OIL SUMP SCREEN				
SETPOINT	ACCESS LEVEL	MINIMUM VALUE	MAXIMUM VALUE	DEFAULT
Manual Pump	Operator	Disabled	Enabled	Disabled
Low Pressure Limit	Service	10 PSID	40 PSID	25 PSID
Pre-lube Time	Service	15 Seconds	60 Seconds	30 Seconds
Coastdown Time	Service	150 Seconds	600 Seconds	150 Seconds
Heater Setpoint	Service	125 °F	155 °F	140 °F

ELECTROMECHANICAL STARTER SCREEN				
SETPOINT	ACCESS LEVEL	MINIMUM VALUE	MAXIMUM VALUE	DEFAULT
Local Motor Current Limit	Operator	30 %	100 %	100 %
Pulldown Demand Limit	Operator	30 %	100 %	100 %
Pulldown Demand Time	Operator	0 Min	255 Min	0 Min

TABLE 11 - PROGRAMMABLE SETPOINT VALUES (CONT'D)

(MOD "B") SOLID STATE STARTER SCREEN				
SETPOINT	ACCESS LEVEL	MINIMUM VALUE	MAXIMUM VALUE	DEFAULT
Local Motor Current Limit	Operator	30 %	100 %	100 %
Pulldown Demand Limit	Operator	30 %	100 %	100 %
Pulldown Demand Time	Operator	0 Min	255 Min	0 Min
Full Load Amps	Service	35 Amps	1050 Amps	35 Amps
Voltage Range	Service	Disabled, 200-208, 220-240, 380, 400, 415, 440-480, 550 – 600		Disabled
Starting Current	Service	310 Amps	3300 Amps	310 Amps
Open SCR	Service	Disabled	Enabled	Disabled
Shorted SCR	Service	Disabled	Enabled	Enabled

VARIABLE SPEED DRIVE SCREEN				
SETPOINT	ACCESS LEVEL	MINIMUM VALUE	MAXIMUM VALUE	DEFAULT
Local Motor Current Limit	Operator	30 %	100 %	100 %
Pulldown Demand Limit	Operator	30 %	100 %	100 %
Pulldown Demand Time	Operator	0 Min	255 Min	0 Min
Filter Inhibit	Service	Disabled	Enabled	Disabled

VARIABLE SPEED DRIVE DETAILS SCREEN (VARIABLE SPEED DRIVE SUBSCREEN)				
SETPOINT	ACCESS LEVEL	MINIMUM VALUE	MAXIMUM VALUE	DEFAULT
Local Motor Current Limit	Operator	30 %	100 %	100 %
Pulldown Demand Limit	Operator	30 %	100 %	100 %
Pulldown Demand Time	Operator	0 Min	255 Min	0 Min

ADAPTIVE CAPACITY CONTROL DETAILS SCREEN (VARIABLE SPEED DRIVE SUBSCREEN)				
SETPOINT	ACCESS LEVEL	MINIMUM VALUE	MAXIMUM VALUE	DEFAULT
Local Motor Current Limit	Service	30 %	100 %	100 %
Pulldown Demand Limit	Service	30 %	100 %	100 %
Pulldown Demand Time	Service	0 Min	255 Min	0 Min
Stability Limit	Service	1000	7000	4500
Surge Margin Adjust	Service	0.0 Hz	25.0 Hz	0.0 Hz
ACC Auto Map Print	Service	Disabled	Enabled	Disabled

HARMONIC FILTER (VARIABLE SPEED DRIVE SUBSCREEN)				
SETPOINT	ACCESS LEVEL	MINIMUM VALUE	MAXIMUM VALUE	DEFAULT
Local Motor Current Limit	Operator	30 %	100 %	100 %
Pulldown Demand Limit	Operator	30 %	100 %	100 %
Pulldown Demand Time	Operator	0 Min	255 Min	0 Min

C

TABLE 11 - PROGRAMMABLE SETPOINT VALUES (CONT'D)

HARMONIC FILTER DETAILS SCREEN (HARMONIC FILTER SUBSCREEN)				
SETPOINT	ACCESS LEVEL	MINIMUM VALUE	MAXIMUM VALUE	DEFAULT
Local Motor Current Limit	Operator	30 %	100 %	100 %
Pulldown Demand Limit	Operator	30 %	100 %	100 %
Pulldown Demand Time	Operator	0 Min	255 Min	0 Min

MOTOR TEMPERATURE SCREEN (MOTOR SUBSCREEN)				
SETPOINT	ACCESS LEVEL	MINIMUM VALUE	MAXIMUM VALUE	DEFAULT
Winding Sensor Mode	Service	None, Analog, Digital, Analog & Digital		None
Winding Cutout	Service	150 °F	300 °F	265 °F
Bearing Sensor Mode	Service	None, Analog, Digital, Analog & Digital		None
Bearing Cutout	Service	100 °F	180 °F	180 °F
Motor Cooling Pump	Service	Disabled	Enabled	Disabled
Motor Cooling Pump Mode	Service	Automatic	Manual	Automatic
Phase A (Active Sensor)	Service	None, A1, A2, A1 & A2		None
Phase B (Active Sensor)	Service	None, B1, B2, B1 & B2		None
Phase C (Active Sensor)	Service	None, C1, C2, C1 & C2		None
Bearing (Active Sensor)	Service	None, Sensor 1, Sensor 2, Sensor 1 & 2		None

SETPOINTS SCREEN				
SETPOINT	ACCESS LEVEL	MINIMUM VALUE	MAXIMUM VALUE	DEFAULT
Local Leaving Chilled Liquid Temperature - Setpoint	Operator	38.0 °F - Water 36.0 °F - Sm Frz 10.0 °F - Brine	70.0 °F	45.0 °F
Local Leaving Chilled Liquid Temperature - Range	Operator	10.0 °F	20.0 °F	20.0 °F
LChLT Cycling Offset - Shutdown	Operator	1.0 °F	64.0 °F	4.0 °F or highest allowed value, whichever is lower.
LChLT Cycling Offset - Restart	Operator	0.0 °F	70.0 °F	0.0 °F
Remote Analog Input Range	Operator	0 - 10 VDC	2 - 10 VDC	0 - 10 VDC
Motor Current Limit	Operator	30 %	100 %	100 %
Pulldown Demand Limit	Operator	30 %	100 %	100 %
Pulldown Demand Time	Operator	0 Min	255 Min	0 Min

TABLE 11 - PROGRAMMABLE SETPOINT VALUES (CONT'D)

SETUP SCREEN				
SETPOINT	ACCESS LEVEL	MINIMUM VALUE	MAXIMUM VALUE	DEFAULT
Set Date	Operator	16/01/1963	01/01/4000	01/01/1999
Set Time	Operator	12:00 AM or 00:00	11:59 PM or 23:59	12:00 AM or 00:00
Clock	Operator	Disable	Enable	Enable
12/24 Hr (Clock Mode)	Operator	12 Hr Mode	24 Hr Mode	12 Hr Mode

SCHEDULE SCREEN (SETUP SUBSCREEN)				
SETPOINT	ACCESS LEVEL	MINIMUM VALUE	MAXIMUM VALUE	DEFAULT
Schedule	Operator	Disabled	Enabled	Disabled
Schedule Data: Sunday through Saturday, Start Time and Stop Time, Standard Week and six Exception Weeks	Operator	12:00 AM or 00:00	11:59 PM or 23:59	12:00 AM or 00:00
Repeat Sunday	Operator	No	Yes	No
Repeat Exceptions	Operator	No	Yes	No

USER SCREEN (SETUP SUBSCREEN)				
SETPOINT	ACCESS LEVEL	MINIMUM VALUE	MAXIMUM VALUE	DEFAULT
Data Display Mode	Operator	English or Metric		English
User ID (ID 1 through 4)	Service	1	9999	1
User Password (ID 1 through 4)	Service	0	9999	0
User Level (ID 1 through 4)	Service	0 - View, 1 - Operator, 2 - Service		0

COMMS SCREEN (SETUP SUBSCREEN)				
SETPOINT	ACCESS LEVEL	MINIMUM VALUE	MAXIMUM VALUE	DEFAULT
Chiller ID	Operator	0	255	0
Baud Rate (Printer Setup and COM 2)	Operator	1200, 2400, 4800, 9600, 19200, 38400, 57600		19200
Data Bits (Printer Setup and COM 2)	Operator	5 Bits, 6 Bits, 7 Bits, 8 Bits		8 Blts
Parity (Printer Setup)	Operator	None, Odd, Even		None
Parity (COM 2)	Operator	None, Odd, Even		Odd
Stop Bits (Printer Setup and COM 2)	Operator	1 Bit	2 Bits	1 Bit

C

TABLE 11 - PROGRAMMABLE SETPOINT VALUES (CONT'D)

PRINTER SCREEN (SETUP SUBSCREEN)				
SETPOINT	ACCESS LEVEL	MINIMUM VALUE	MAXIMUM VALUE	DEFAULT
Log Start Time	Operator	12:00 AM or 00:00	11:59 PM or 23:59	12:00 AM or 00:00
Output Interval	Operator	1 Min	1440 Min	60 Min
Automatic Printer Logging	Operator	Disabled	Enabled	Disabled
ACC Auto Map Print	Operator	Disabled	Enabled	Disabled
Printer Type	Operator	Okidata, WeighTronix, Epson, Seiko		Okidata
Print Report	View	Status, Setpoint, Schedule, Sales Order, Slot List, Custom Screen Data		Status

OPERATIONS SCREEN (SETUP SUBSCREEN)				
SETPOINT	ACCESS LEVEL	MINIMUM VALUE	MAXIMUM VALUE	DEFAULT
Control Source	Operator	Local, ISN, Analog, Digital, Modem		Local
Number Of Starts	Admin	0	99999	0
Operating Hours	Admin	0 Hours	876600 Hours	0 Hours
Hot Gas (Bypass)	Service	Disabled	Enabled	Disabled
(Refrigerant) Level Control	Service	Disabled	Enabled	Disabled
Chiller Model	Service	CVHA, CHVB, CVHE, CVHF		CVHA
Refrigerant	Service	R11	R123	R11

HISTORY SCREEN				
SETPOINT	ACCESS LEVEL	MINIMUM VALUE	MAXIMUM VALUE	DEFAULT
Select Fault	View	Normal, Running, Fault #		Normal

CUSTOM VIEW SETUP SCREEN (CUSTOM VIEW SUBSCREEN)				
SETPOINT	ACCESS LEVEL	MINIMUM VALUE	MAXIMUM VALUE	DEFAULT
Custom Slot (1 through 10)	Operator	0	65535	0

TREND SETUP SCREEN (TREND SUBSCREEN)				
SETPOINT	ACCESS LEVEL	MINIMUM VALUE	MAXIMUM VALUE	DEFAULT
Chart Type	Operator	Continuous	One Screen	Continuous
Collection Interval	Operator	1 Second	3600 Seconds	60 Seconds
Data Point Slot # (1 through 6)	Operator	0	65535	0
Data Point Min (1 through 6)	Operator	Varies with each slot number programmed		
Data Point Max (1 through 6)	Operator	Varies with each slot number programmed		

APPENDIX D - KIT INSTALLATION CHECKLIST

- 1. Read the Retrofit Kit installation manual.
- 2. Review Trane chiller configuration and parts included with the Retrofit Kit. Procure any necessary or optional parts required for kit installation.
- 3. Retrieve any useful operating data and service rating plate from existing chiller controls. Record below.
- 4. Lock out and tag out chiller electrical supply.
- 5. Stop chilled and condenser liquid flow. Remove refrigerant and oil from chiller. Purge the chiller with nitrogen gas.
- 6. Disconnect and label wiring for the following components from the existing control unit:
 - Vent line solenoid
 - Purge unit
 - Oil Pump and heater
 - Motor winding and bearing sensors
 - PRV actuator
 - Starter wiring
 - Liquid flow switches
 - Remote devices
- 7. Remove existing chiller control panel.
- 8. Fit OptiView panel to chiller, using existing hardware or optional mounting assembly.
- 9. Install Trane purge Human Interface Module in auxiliary junction box, as necessary.
- 10. Mount auxiliary and small junction boxes.
- 11. Install the high pressure cutout switch, 3R relay, motor sensor RTD module, and terminal strips in auxiliary junction box. Install surge suppressors on the 3R relay.
- 12. Install field-sourced relays for the condenser and chilled liquid pumps, as required. Install surge suppressors on the relays.
- 13. Mount the remaining small junction box for the low oil pressure cutout switch (LOPCO).
- 14. Mount the LOPCO in the small junction box.
- 15. Verify correct external I/O board factory wiring, including wiring at terminal block 7.
- 16. Mount and label the two PRV solid state relays in the OptiView panel.
- 17. Create and label a wiring harness for the chiller purge unit. Route the harness to the small junction box.
- 18. Install the oil temperature sensor (RT3).
- 19. Install the condenser and chilled liquid leaving and entering temperature sensors (RT4, RT5, RT1, RT9).
- 20. Install the oil pressure transducers (LOP, HOP) in the appropriate oil lines.
- 21. Plumb the tubing for the LOPCO.
- 22. Create and label a wiring harness for the LOPCO switch. Route the harness to the small junction box installed at step 13 of this checklist.
- 23. Install the condenser pressure transducer (CPT) in the condenser shell.
- 24. Plumb the tubing for the condenser high pressure cutout switch (HPCO).
- 25. Install the evaporator pressure transducer (EPT) in the evaporator shell.
- 26. Install the discharge temperature sensor (RT2) in the discharge coupling, welding in a 1/2 inch NPT thread-o-let for the sensor as necessary.
- 27. If installing the optional refrigerant temperature sensor kit, install the condenser, evaporator, and drop leg sensors (RT17, RT7, RT6). Weld in thread-o-lets for the sensors as necessary.
- 28. Route the sensor harness through cutout "A" in the OptiView panel. Connect the harness to J7 (RT17 only), J8, and J9 on the microboard.
- 29. Measure and terminate the sensor wiring harness(es). Connect the wiring harness to the sensors installed in the chiller.

30. Measure and record the resistance of the motor winding temperature sensor for each phase. Record the resistance in the space below.
- | | | |
|----|----|----|
| A: | B: | C: |
|----|----|----|
31. Create and label a motor winding sensor wiring harness. Route the harness from the motor RTD junction box to the RTD module in the auxiliary junction box.
32. Connect the motor RTD harness to the signal conditioners, including the ground wires at the motor RTD junction box and auxiliary panel.
33. Install the inboard and outboard bearing temperature sensors (RT15 and RT16).
34. Create and label a wiring harness to go from each bearing sensor to the analog I/O board in the OptiView panel.
35. Create and label a wiring harness to go from the motor RTD module to the analog I/O board in the OptiView panel.
36. Route the motor RTD and bearing sensor wiring harnesses through cutout "A" or "F" in the back wall of the OptiView panel. Make the sensor wiring connections on the analog I/O board.
37. Create and label a wiring harness to go from the vent line solenoid (as equipped) to the small junction box. Install a surge suppressor on the vent line solenoid.
38. If required, install the Trane PRV actuator, part number MOT2970.
39. Install MOV varistors on the open and close circuits of the PRV actuator.
40. Create and label a wiring harness to go from the PRV actuator to the small junction box.
41. Create and label a wiring harness for the oil pump and oil heater. Route the wiring harness to the auxiliary junction box.
42. Connect the oil pump wiring to the 3R relay in the auxiliary junction box.
43. Create and label a wiring harness to go from the components in the auxiliary junction box to the small junction box. Include the oil heater and ground wiring.
44. Create and label a wiring harness to connect all components wired to small junction box to the OptiView control panel. Route the harness through cutout "B" in the back wall of the OptiView panel.
45. Connect the wiring harness from the small junction box to the appropriate connections in the OptiView panel.
46. Create, label and connect the internal panel wiring for the two PRV solid state relays.
47. Create, label, and connect the motor cooling pump to the digital I/O board in the OptiView panel (as equipped).
48. Make any remote device connections.
49. If a printer is being installed, connect the printer wiring to the COM1 serial port on the OptiView microboard.
50. Install the CM-2 board, diode bridge and slide resistor assembly in the OptiView panel.
51. Make the appropriate CM-2 board connections.
52. For chillers equipped with high voltage starters or starters which require the starter relay kit, remove the jumper between 1 and 53 on terminal block six in the OptiView panel.
53. Install the necessary current transformer (CT) kit in the starter or motor cabinet.
54. Using the E-M wiring harness, connect the CT kit to the diode bridge in the OptiView panel. Route the wiring harness through cutout "D" in the back wall of the panel.
55. Calculate and adjust the slide resistor assembly to the proper resistance.
56. Shunt (bridge) the pre-existing current transformers in the motor starter cabinet.
57. Set the starter type (S1) and LRA/FLA ratio (R16) on the CM-2 board.
58. Place the kit warning label on the front door of the auxiliary junction box. Touch up any panel finish damage with the included paint.
59. Re-wire the chiller motor starter, installing components as required by the starter design. Make all appropriate connections to the OptiView panel.

- 60. Verify that surge suppressors have been installed on all relays, solenoid coils and motor coils that are supplied with power from the OptiView panel.
- 61. Verify all chiller wiring is properly terminated and all connections have been made.
- 62. Pressurize and leak check the chiller. Evacuate the chiller when no leaks are present.
- 63. Replace the refrigerant and oil in the chiller with the charge recommended by the chiller manufacturer.
- 64. Place microboard jumpers and DIP switches in the appropriate position according to the microboard model and chiller configuration.
- 65. Verify that all jumpers (wire and bridge type) on the analog and digital boards are set properly. Make any changes as necessary.
- 66. Apply 115 VAC power to the OptiView panel. Verify the panel powers up properly.
- 67. Program the appropriate software setpoints and settings using the OptiView keypad and display. Use any setpoints and information obtained from the original chiller controls.
- 68. Check motor winding sensors for proper operation compare resistance recorded in step #30 with analog motor winding sensor data in Appendix A of this manual. Adjust winding setpoints appropriately in OptiView software.
- 69. Test starter operation, using the appropriate test for the applicable starter.
- 70. Perform the motor rotation test.
- 71. Start the chiller, verifying proper operation.
- 72. Load the chiller to 100% of full load amps (FLA).
- 73. Verify voltage between J1-1 and J1-2 of the CM-2 board is between 0.90 and 1.05 VDC.
- 74. Drive chiller load to 105% of FLA, calibrating the 105% overload at R8 on the CM-2 board
- 75. Calibrate the OptiView FLA display at R34 of the CM-2 board to 100% FLA.
- 76. Return any OptiView setpoints or controls adjusted to achieve full load on the chiller.
- 77. Program any remaining OptiView setpoints or controls.
- 78. Affix the original chiller service rating plate to OptiView cabinet.

The following factors can be used to convert from English to the most common SI Metric values.

TABLE 12 - SI METRIC CONVERSION

MEASUREMENT	MULTIPLY ENGLISH UNIT	BY FACTOR	TO OBTAIN METRIC UNIT
Capacity	Tons Refrigerant Effect (ton)	3.516	Kilowatts (kW)
Power	Horsepower	0.7457	Kilowatts (kW)
Flow Rate	Gallons / Minute (gpm)	0.0631	Liters / Second (l/s)
Length	Feet (ft)	0.3048	Meters (m)
	Inches (in)	25.4	Millimeters (mm)
Weight	Pounds (lbs)	0.4538	Kilograms (kg)
Velocity	Feet / Second (fps)	0.3048	Meters / Second (m/s)
Pressure Drop	Feet of Water (ft)	2.989	Kilopascals (kPa)
	Pounds / Square Inch (psi)	6.895	Kilopascals (kPa)

TEMPERATURE

To convert degrees Fahrenheit (°F) to degrees Celsius (°C), subtract 32° and multiply by 5/9 or 0.5556.

Example: $(45.0^{\circ}\text{F} - 32^{\circ}) \times 0.5556 = 27.2^{\circ}\text{C}$

To convert a temperature range (i.e., a range of 10°F) from Fahrenheit to Celsius, multiply by 5/9 or 0.5556.

Example: $10.0^{\circ}\text{F range} \times 0.5556 = 5.6^{\circ}\text{C range}$

NOTES



P.O. Box 1592, York, Pennsylvania USA 17405-1592
Copyright © by Johnson Controls 2015
Form 160.10-N1 (615)
Issue Date: June 23, 2015
Supersedes: 160.10-N1 (310)

800-861-1001
www.johnsoncontrols.com

Subject to change without notice. Printed in USA
ALL RIGHTS RESERVED