



LIQUID COOLED OPTISPEED COMPRESSOR DRIVE

SERVICE INSTRUCTIONS

Supersedes: 160.00-M4 (304)

Form 160.00-M4 (1007)

**MODELS: VSD292
VSD351
VSD419
VSD424
VSD503
VFD608**



00633VIP

**292 HP – 50 Hz, 400 VAC (P/N 371-03700-XXX)
351 HP – 60 Hz, 460 VAC (P/N 371-02767-XXX)
419 HP – 50 Hz, 400 VAC (P/N 371-03789-XXX)
424 HP – 60 Hz, 575 VAC (P/N 371-04881-XXX)
503 HP – 60 Hz, 460 VAC (P/N 371-03789-XXX)
608 HP – 60 Hz, 575 VAC (P/N 371-04563-XXX)**

IMPORTANT!

READ BEFORE PROCEEDING!

GENERAL SAFETY GUIDELINES

This equipment is a relatively complicated apparatus. During installation, operation, maintenance or service, individuals may be exposed to certain components or conditions including, but not limited to: refrigerants, oils, materials under pressure, rotating components, and both high and low voltage. Each of these items has the potential, if misused or handled improperly, to cause bodily injury or death. It is the obligation and responsibility of operating/service personnel to identify and recognize these inherent hazards, protect themselves, and proceed safely in completing their tasks. Failure to comply with any of these requirements could result in serious damage to the equipment and the property in

which it is situated, as well as severe personal injury or death to themselves and people at the site.

This document is intended for use by owner-authorized operating/service personnel. It is expected that this individual possesses independent training that will enable them to perform their assigned tasks properly and safely. It is essential that, prior to performing any task on this equipment, this individual shall have read and understood this document and any referenced materials. This individual shall also be familiar with and comply with all applicable governmental standards and regulations pertaining to the task in question.

SAFETY SYMBOLS

The following symbols are used in this document to alert the reader to areas of potential hazard:



DANGER indicates an imminently hazardous situation which, if not avoided, will result in death or serious injury.



CAUTION identifies a hazard which could lead to damage to the machine, damage to other equipment and/or environmental pollution. Usually an instruction will be given, together with a brief explanation.



WARNING indicates a potentially hazardous situation which, if not avoided, could result in death or serious injury.

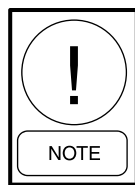

NOTE is used to highlight additional information which may be helpful to you.



External wiring, unless specified as an optional connection in the manufacturer's product line, is NOT to be connected inside the micro panel cabinet. Devices such as relays, switches, transducers and controls may NOT be installed inside the micro panel. NO external wiring is allowed to be run through the micro panel. All wiring must be in accordance with YORK's published specifications and must be performed ONLY by qualified YORK personnel. YORK will not be responsible for damages/problems resulting from improper connections to the controls or application of improper control signals. Failure to follow this will void the manufacturer's warranty and cause serious damage to property or injury to persons.

WARNING!



The Control/VSD Cabinet contains lethal High AC and DC voltages. Before performing service inside the cabinet, remove the AC supply feeding the chiller and verify using a non-contact voltage sensor.

The DC Voltage on the VSD DC Bus will take 5 minutes to bleed off, after AC power is removed. Always check the DC Bus Voltage with a Voltmeter to assure the capacitor charge has bled off before working on the system.

- NEVER short out the DC Bus to discharge the filter capacitors.**
- NEVER place loose tools, debris, or any objects inside the Control Panel/VSD Cabinet.**
- NEVER allow the Control Panel VSD Cabinet doors to remain open if there is a potential for rain to enter the panel. Keep doors closed and assure all latches are engaged on each door unless the unit is being serviced.**
- ALWAYS lockout the disconnect supplying AC to the chiller.**
- The 1L Line Inductor will reach operating temperatures of over 300° F. DO NOT open panel doors during operation. Assure the inductor is cool whenever working near the inductor with power off.**

CHANGEABILITY OF THIS DOCUMENT

In complying with YORK's policy for continuous product improvement, the information contained in this document is subject to change without notice. While YORK makes no commitment to update or provide current information automatically to the manual owner, that information, if applicable, can be obtained by contacting the nearest Johnson Controls Service office.

It is the responsibility of operating/service personnel to verify the applicability of these documents to the equipment in question. If there is any question in the mind of operating/service personnel as to the applicability of these documents, then prior to working on the equipment, they should verify with the owner whether the equipment has been modified and if current literature is available.

TABLE OF CONTENTS

Table of Contents

OPTISPEED COMPRESSOR DRIVE GENERAL INFORMATION.....	5
Reference Instructions	5
OptiSpeed Model Number Definitions	6
OPTISPEED/HARMONIC FILTER COMPONENT OVERVIEW	7
OptiSpeed Compressor Drive 292, 351 & 424 Hp	7
OptiSpeed Compressor Drive 419, 503 & 608 HP	12
Harmonic Filter Option General Information	12
Harmonic Filter Option 292, 351 & 424 Hp	20
Harmonic Filter Option 419, 503 & 608 Hp	26
575 VAC Harmonic Filter Differences from 460 VAC Harmonic Filter	26
OPTISPEED COMPRESSOR DRIVE CONTROL SYSTEM OVERVIEW.....	30
The Control Center	30
OptiSpeed and Optional Harmonic Filter Logic Control Board	30
Microcomputer Control Panel VSD Related Keypad Functions	32
OptiView Control Panel VSD Functions	33
VSD ADAPTIVE CAPACITY CONTROL	33
Setpoint Requirements	33
Stability Requirements	33
Full Open Vane Operation	33
Effects of Surge	33
Drive No Slowing Down	34
Drive Does Not Respond to Chiller Surging	34
Stability Limit Adjustment	34
Surge Margin Adjustment	34
Software Version Changes	35
SAFETY SHUTDOWNS.....	35
General Information	35
Motor or Starter – Current Imbalance	35
VSD - 105 % Motor Current Overload	36
VSD - High Converter Heatsink Temperature	36
VSD - High Inverter Baseplate Temperature (292, 351 & 424 Hp drive only)	36
VSD - High Phase (X) Inverter Baseplate Temperature (491, 503 & 608 Hp drive only)	36
VSD - Precharge Lockout	37
Harmonic Filter - High Baseplate Temperature	37
Harmonic Filter - High Total Demand Distortion	37
CYCLING SHUTDOWNS.....	38
General Information	38
VSD - DC Bus Voltage Imbalance	38
VSD - High DC Bus Voltage	38
VSD - High Internal Ambient Temperature	39
VSD - High Phase A (or B, C) Instantaneous Current	39
VSD - Initialization Failed	40
VSD - Invalid Current Scale Selection	40
VSD - Logic Board Power Supply	40
VSD - Logic Board Processor	41
VSD - Low Converter Heatsink Temperature	41
VSD - Low DC Bus Voltage	42
VSD - Low Inverter Baseplate Temperature	42
VSD - Phase A (B, C) Gate Driver	42
VSD - Precharge - DC Bus Voltage Imbalance	43
VSD - Precharge - Low DC Bus Voltage	43
VSD - Run Signal	43
VSD - Serial Communications	44
VSD - Single Phase Input Power	44

TABLE OF CONTENTS - CON'T

VSD - Stop Contacts Open	44
Harmonic Filter - 110 % Input Current Overload	45
Harmonic Filter - DC Bus Voltage Imbalance	45
Harmonic Filter - DC Current Transformer 1(or 2)	46
Harmonic Filter - High DC Bus Voltage.....	46
Harmonic Filter - High Phase A (B, C) Current.....	47
Harmonic Filter - Logic Board Or Communications	47
Harmonic Filter - Logic Board Power Supply.....	47
Harmonic Filter - Low DC Bus Voltage	48
Harmonic Filter - Phase Locked Loop.....	48
Harmonic Filter - Precharge - Low DC Bus Voltage	48
Harmonic Filter - Run Signal.....	49
WARNING MESSAGES	49
General Information.....	49
Warning – Vanes Uncalibrated – Fixed Speed.....	49
Warning - Harmonic Filter - Operation Inhibited	49
Warning - Harmonic Filter - Data Loss	49
Start-Up Preparations	50
Circuit Breaker Setup.....	50
OptiView Control Center	51
Micro Computer Control Center.....	52
VSD Frequently Asked Questions	55
Troubleshooting and Component Replacement Procedures.....	59
General Information.....	59
Verify Failure of the OSCD Power Module 292, 351 & 424 Hp Drive.....	59
Verify Failure of the OSCD Power Module 419, 503 & 608 Hp Drive.....	63
Verify Failure of the Harmonic Filter Module 292, 351,424, 419, 503 & 608 Hp Drive.....	66
Replacement of the OSCD Power Module	66
Replacement of the Harmonic Filter Power Module	68
Software Reference List 60 Hz Only	69
Software Reference List 50 Hz Only	71

OPTISPEED COMPRESSOR DRIVE GENERAL INFORMATION

This instruction is to be used in conjunction with the Operation Instructions for YORK Model YT & YK chillers furnished with an optional OptiSpeed Compressor Drive (OSCD).

Reference Instructions

Operation (Unit)	
Model YT, (Centrifugal).....	Form 160.55-O1
Model YK, (Centrifugal)	Form 160.54-O1
Operation (Control Panel)	
Model YT, (Centrifugal)	Form 160.55-O1
Model YK, (Centrifugal)	Form 160.54-O1
Service (Control Panel)	
Model YT, (Centrifugal)	Form 160.55-M1
Model YK, (Centrifugal)	Form 160.54-M1
Wiring Diagram (Control Panel)	
Model YT, (Centrifugal)	Form 160.55-PW2
Model YK, (Centrifugal)	Form 160.54-PW8
Operation (OptiSpeed Compressor Drive).....	Form 160.00-04
Wiring Field Connections (OptiSpeed Compressor Drive)	
Model YT, (Centrifugal)	Form 160.55-PW5
Model YK, (Centrifugal)	Form 160.54-PW5
Replacement Parts List (OptiSpeed Compressor Drive)	Form 160.00-RP4

OPTISPEED MODEL NUMBER DEFINITIONS

VSD351_RKFT_-46

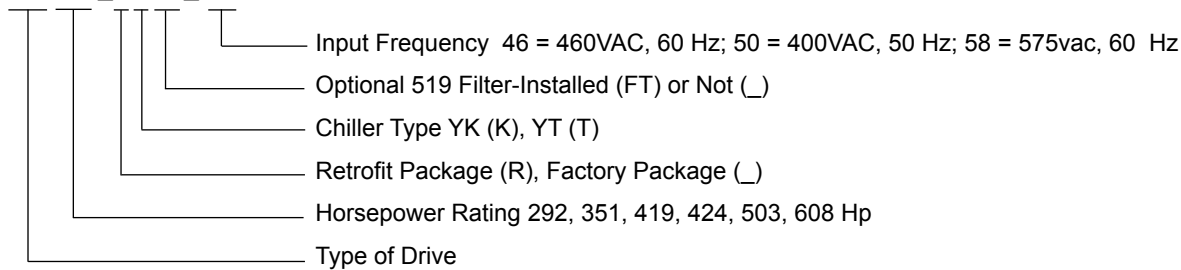

Model Number and Part Numbers:

292 Hp 50 Hz 400 VAC

VSD292_T_-50	371-03700-101
VSD292_K_-50	371-03700-102
VSD292_TFT-50	371-03700-105
VSD292_KFT-50	371-03700-106
VSD292RT_-50	371-03700-111
VSD292RK_-50	371-03700-112
VSD292RTFT-50	371-03700-115
VSD292RKFT-50	371-03700-116

351 Hp 60 Hz 460 VAC

VSD351_T_-46	371-02767-101
VSD351_K_-46	371-02767-102
VSD351_TFT-46	371-02767-105
VSD351_KFT-46	371-02767-106
VSD351RT_-46	371-02767-111
VSD351RK_-46	371-02767-112
VSD351RTFT-46	371-02767-115
VSD351RKFT-46	371-02767-116

419 Hp 50 Hz 400 VAC

VSD419_T_-50	371-03789-105
VSD419_K_-50	371-03789-106
VSD419_TFT-50	371-03789-107
VSD419_KFT-50	371-03789-108
VSD419RT_-50	371-03789-115
VSD419RK_-50	371-03789-116
VSD419RTFT-50	371-03789-117
VSD419RKFT-50	371-03789-118

Model Number and Part Numbers:

424 Hp 60 Hz 575 VAC

VSD424_T_-58	371-04881-101
VSD424_K_-58	371-04881-102
VSD424_TFT-58	371-04881-103
VSD424_KFT-58	371-04881-104
VSD424RT_-58	371-04881-111
VSD424RK_-58	371-04881-112
VSD424RTFT-58	371-04881-113
VSD424RKFT-58	371-04881-114

503 Hp 60 Hz 460 VAC

VSD503_T_-46	371-03789-101
VSD503_K_-46	371-03789-102
VSD503_TFT-46	371-03789-103
VSD503_KFT-46	371-03789-104
VSD503RT_-46	371-03789-111
VSD503RK_-46	371-03789-112
VSD503RTFT-46	371-03789-113
VSD503RKFT-46	371-03789-114

608 Hp 60 Hz 575 VAC

VSD608_T_-58	371-04563-101
VSD608_K_-58	371-04563-102
VSD608_TFT-58	371-04563-103
VSD608_KFT-58	371-04563-104
VSD608RT_-58	371-04563-111
VSD608RK_-58	371-04563-112
VSD608RTFT-58	371-04563-113
VSD608RKFT-58	371-04563-114

OPTISPEED/HARMONIC FILTER COMPONENT OVERVIEW

OptiSpeed Compressor Drive 292, 351 & 424 Hp

The new YORK OptiSpeed Compressor Drive (OSCD) is a liquid cooled, transistorized, PWM inverter in a highly integrated package. This package is small enough to mount directly onto the chiller motor, and small enough to be applied in many retrofit chiller applications. The power section of the drive is composed of four major blocks: an AC to DC rectifier section with an integrated pre-charge circuit, a DC link filter section, a three phase DC to AC inverter section and an output suppression network.

An electronic circuit breaker with ground fault sensing connects the AC line to an AC line inductor and then to the DC converter. The line inductor will limit the amount of fault current so that the electronic circuit breaker is sufficient for protecting the OSCD. Input fuses to the OSCD are no longer needed. The following description of operation is specific for the 351 Hp OSCD unless otherwise noted. Refer to Fig. 1.

The AC to DC semi-converter uses 3 Silicon Controlled Rectifiers (SCR's) and 3 diodes. One SCR and one diode are contained in each module. Three modules are required to convert the 3 phase input AC voltage into DC voltage (1SCR-3SCR) in a three-phase bridge configuration (Fig. 1). The modules are mounted on a liquid cooled heatsink. The use of the SCR's in the semi-converter configuration permits pre-charge of the DC link filter capacitors when the chiller enters the prelude cycle, and they also provides a fast disconnect from the AC line when the chiller enters the coastdown cycle.

When the chiller enters the coastdown cycle the OSCD is turned off, the SCR's in the semi-converter are no longer turned on, and remain in a turned off or non-conducting mode until the next pre-charge cycle. The DC link filter capacitors will start to discharge through the bleeder resistors. When the chiller enters the prelude cycle, the OSCD drive is commanded to pre-charge, the SCR's are gradually turned on with a delay angle to slowly charge the DC link filter capacitors. This is called the pre-charge period, which last for 20-seconds. After the 20-second time period has expired, the SCR's are gated fully on. The SCR Trigger board (031-02060) provides the turn on, and turn off commands for the SCR's during precharge, and during normal running condition as commanded by the OSCD Logic board (031-02077).



Although many of these parts are similar to the parts used in previous Variable Speed Drive (VSD) designs, these parts are only compatible with drives having the base part numbers included on the cover of this form. Failure to use the correct parts may cause major damage to these and other components in the drive. For example, the VSD logic board 031-02077-000 used in this drive is not compatible with 031-01433-000 logic board used in previous designs.

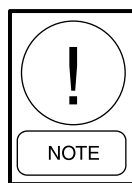

The figures for all horsepower drives are included in this form, but the component identifications are specific for the 351 horsepower drive.

The DC Link filter section of the drive consists of one basic component, a series of electrolytic filter capacitors (C1-C6). These capacitors provide a large energy reservoir for use by the DC to AC inverter section of the OSCD. The capacitors are contained in the OSCD Power Unit. In order to achieve a suitable voltage capability between the DC Link voltage, and the rating of the filter capacitors, two capacitors are placed in series to form a "pair", and then paralleling a suitable number of "pairs" to form a capacitor "bank". In order to assure an equal sharing of the voltage between the series connected capacitors, and to provide a discharge path for the capacitor bank when the OSCD is powered off, "bleeder" resistors (1RES and 2RES) are connected across the capacitor banks. Four bleeder resistors are required on the 575 VAC OSCD. Refer to Fig. 2 The "Bleeder" resistors are mounted on the side of the Power Unit.

The DC to AC inverter section of the OSCD serves to convert the DC voltage back to AC voltage at the proper magnitude and frequency as commanded by the OSCD Logic board. The inverter section is actually composed of one power unit. This power unit is composed of very fast switching transistors called an Insulated Gate Bipolar Transistor (IGBT) module (1MOD) mounted on the same liquid cooled heatsink as the semi-converter modules, the DC Link filter capacitors (C1-C6), a semi-converter, and an OSCD Gate Driver board (031-02061).

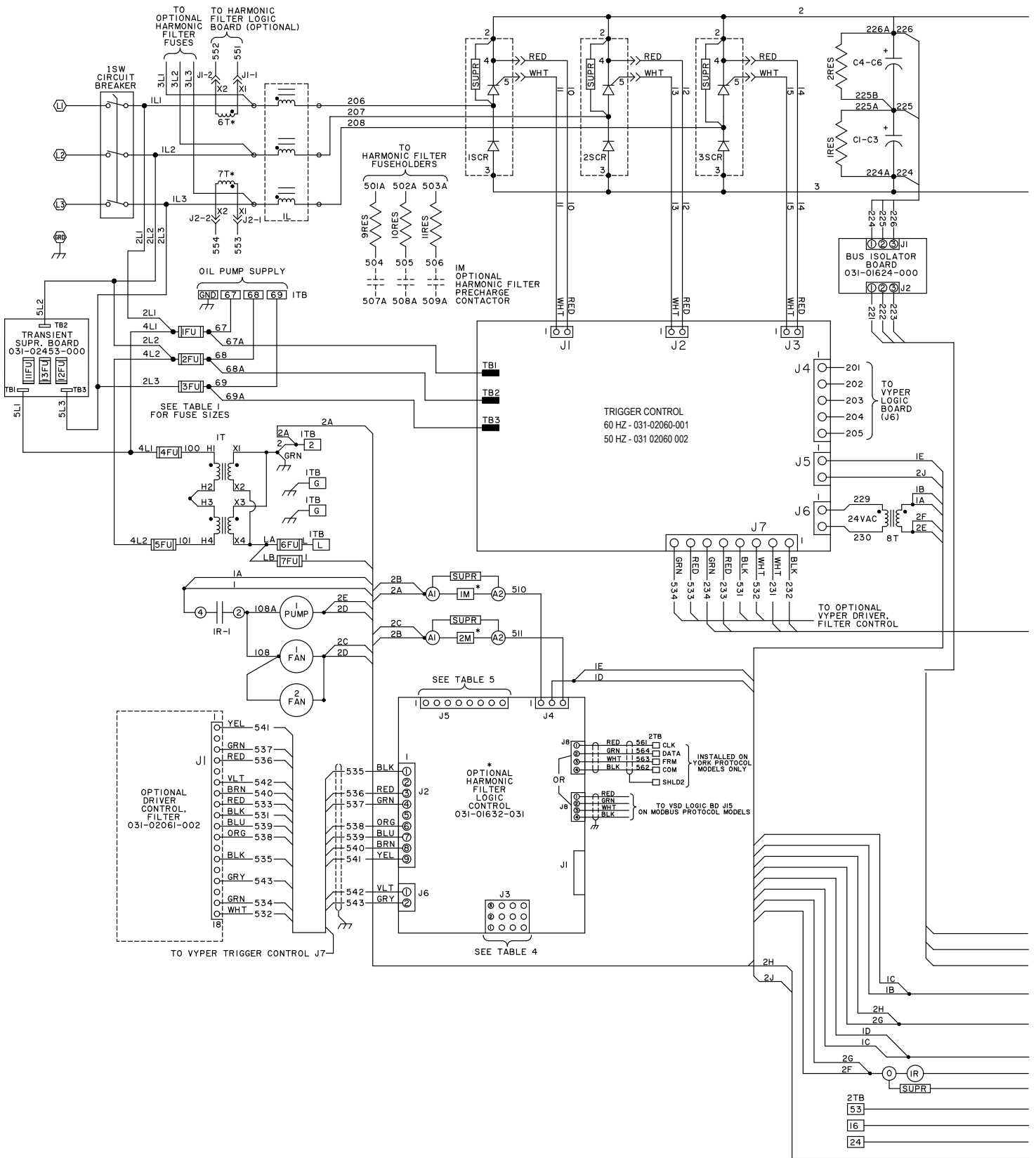
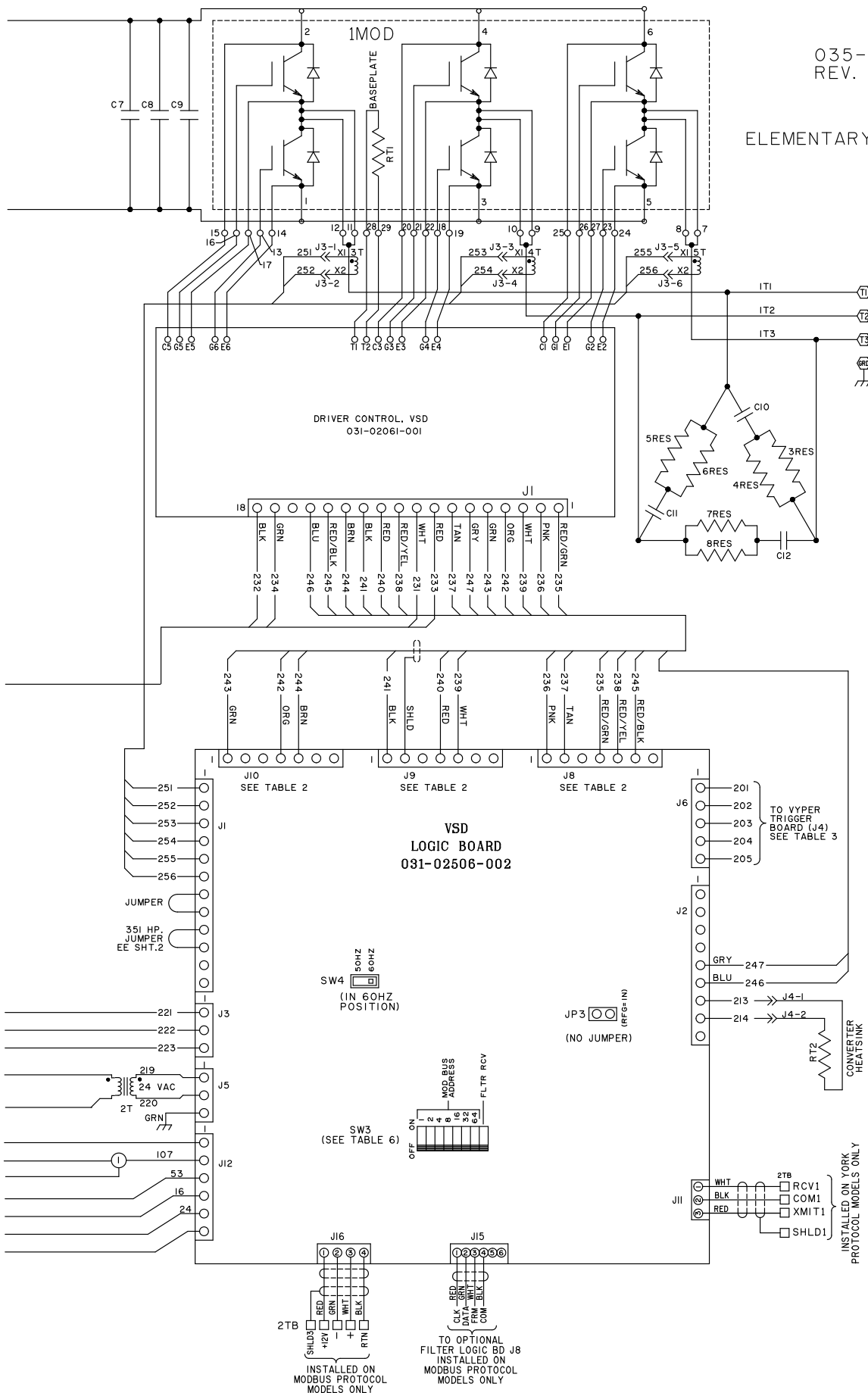

FIG. 1 – ELEMENTARY WIRING DIAGRAM 292 & 351 HP



035-17889.SHTI
REV. D

ELEMENTARY WIRING DIAGRAM

TABLE 1

UNIT STYLE	FUSING - IFU, 2FU, 3FU
YT / YS	5A, 500V, FERRAZ-SHAUMUT ATQ-5
YK	7A, 500V, FERRAZ-SHAUMUT ATQ-7

TABLE 2
VYPERLOGIC BOARD - J8, J9, J10 PINOUT

CONNECTOR PIN	FUNCTION
1	FAULT
2	GN2/SHLD
3	+5V
4	UPPER PHASE
5	LOWER PHASE
6	SW - 7.5V
7	GN2/SHLD
8	GN2/SHLD

NOTE: GN2/SHLD NOT CONNECTED AT DRIVER CONTROL END

TABLE 3
VYPERLOGIC BOARD - J6 PINOUT

CONNECTOR PIN	FUNCTION
1	+5V FEED
2	PH LOSS OUT
3	PRECHG IN
4	SCRTRIG IN
5	+7.5V FEED

TABLE 4
OPTIONAL HARMONIC FILTER LOGIC BOARD - J3 PINOUT

CONNECTOR PIN	IDENTIFIER	FUNCTION
1	552	TO 6T-X2 - OPTION
2	551	TO 6T-X1 - OPTION
3	554	TO 7T-X2 - OPTION
4	553	TO 7T-X1 - OPTION
5	WHITE	TO 1DCCT - OPTION
6	RED	TO 1DCCT - OPTION
7	BLK	TO 1DCCT - OPTION
8	-	TO J3 PIN 9
9	-	TO J3 PIN 8
10	RED	TO 2DCCT - OPTION
11	BLK	TO 2DCCT - OPTION
12	WHITE	TO 2DCCT - OPTION

TABLE 5
OPTIONAL HARMONIC FILTER LOGIC BOARD - J5 PINOUT

CONNECTOR PIN	IDENTIFIER	FUNCTION
1	550	TO J2-1, OPTIONAL 2022 BOARD
2	529	TO J2-2, OPTIONAL 2022 BOARD
3	528	TO J2-3, OPTIONAL 2022 BOARD
4	527	TO J2-4, OPTIONAL 2022 BOARD
5	523	TO J2-3, OPTIONAL 1624 BOARD
6	522	TO J2-2, OPTIONAL 1624 BOARD
7	521	TO J2-1, OPTIONAL 1624 BOARD
8	-	NOT USED

TABLE 6
SW3 POSITIONS

POSITION NUMBER	YORK PROTOCOL MODELS	MODBUS PROTOCOL MODELS
1	OFF	ON
2	OFF	OFF
4	OFF	OFF
8	OFF	OFF
16	OFF	OFF
32	OFF	OFF
64	OFF	OFF
FLTR RCV	OFF	ON

FIG. 1 (CONT'D) - ELEMENTARY WIRING DIAGRAM 292 & 351 HP

LD13101

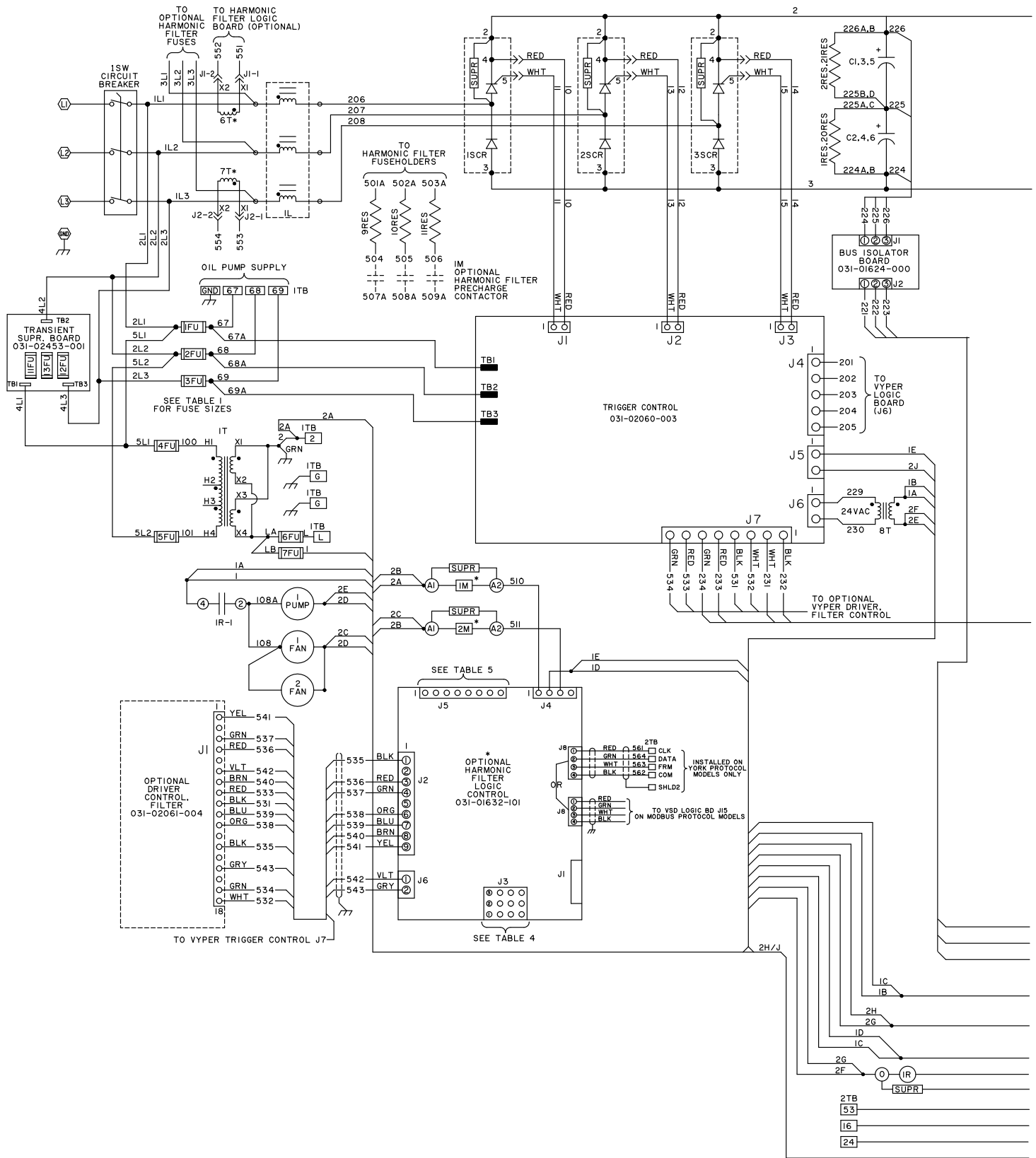

FIG. 2 – ELEMENTARY WIRING DIAGRAM 424 HP

LD13102

The gate driver board conditions the turn on, and turn off commands to the IGBT's output transistors as commanded by the OSCD Logic board. The gate driver board is mounted directly on top of the IGBT module, and it is held in place with mounting screws and soldered to the IGBT module. This improves reliability by eliminating the gate wires and their possible failure.

In order to minimize the parasitic inductance between the IGBT module and the capacitor bank, copper plates which electrically connect the capacitors to one another and to the IGBT module are connected together using a "laminated bus" structure. This "laminated bus" structure is actually composed of a pair of copper plates sandwiched between and coated with an insulating material acting as the separator/insulator. The "laminated bus" structure forms a parasitic capacitor which acts as a small valued capacitor, effectively canceling the parasitic inductance of the copper plates themselves. To further cancel the parasitic inductances, a series of small film capacitors (C7-C9) are connected between the positive and negative plates at the IGBT module.

The OSCD output suppression network is composed of a series of capacitors (C10-C12) and resistors (3RES-8RES) connected in a three-phase delta configuration. The parameters of the suppression network components are chosen to work in unison with the parasitic inductance of the DC to AC inverter sections in order to simultaneously limit both the rate of change in voltage and the peak voltage applied to the motor windings. By limiting the peak voltage to the motor windings, as well as the rate-of-change in motor voltage, we can avoid problems commonly associated with PWM motor drives, such as stator-winding end-turn failures and electrical fluting of motor bearings.

Other sensors and boards are used to convey information back to the OSCD Logic board, and provide safe operation of the OptiSpeed Compressor Drive. The IGBT module contains a thermistor temperature sensor (RT1) that provides temperature information back to the OSCD logic board via the gate driver board. The AC to DC semi-converter heatsink temperature is also monitored using a thermistor temperature sensor (RT2). This sensor is directly connected to the OSCD Logic Board. The Bus Voltage Isolator board (031-01624) utilizes three resistors on the board to provide a "safe" resistance between the DC link filter capacitors located in the OSCD power unit and the OSCD logic board. It provides the means to sense the positive, midpoint and negative voltage connection points of the OSCD DC link. Three Current Transformers (3T-5T) monitor the

output current from the OSCD power unit and are used to protect the motor from overcurrent conditions.

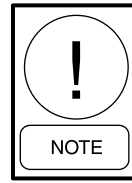

The 575 VAC OSCD require different part number boards than the 460 VAC OSCD or the 50Hz OSCD.

OptiSpeed Compressor Drive 419, 503 & 608 HP

The 419, 503 and 608 Hp OSCD's function in the same manner as the 351 Hp and have the same components, but more of them. The power requirements of these higher horse power drives require more capacitors in the DC Link, and 3 IGBT modules are needed. One module is used for each output phase. Each IGBT module contains a thermistor, and they are connected to the OSCD logic board. The IGBT gate driver board is mounted on top of the IGBT module as in the 351 Hp, but it only contains 2 drivers. The modules and the boards are not interchangeable between the different horsepower drives.

575 VAC Drive Differences From 460 VAC Drive

The 424 and 608 Horsepower OSCD are 575 VAC versions of the 460 VAC 351 and 503 Hp OSCD. A few changes to the OSCD are required.

First, the input SCR's voltage rating is increased as well as the voltage rating for the Bus caps. The OSCD drive logic is change to accommodate the higher bus voltage. More bleeder resistors of a higher resistance value are required to support the higher bus voltage.

Form 160.00-RP4 contains all of the different part number required for these products. **It is very important not to mix parts between different voltage ranges OSCD.**

Harmonic Filter Option General Information

The OptiSpeed Compressor Drive (OSCD) system may also include an optional harmonic filter and high frequency trap designed to meet the IEEE Std 519 -1992, "IEEE Recommended Practices and Requirements for Harmonic Control in Electrical Power Systems". The harmonic filter is offered as a means to improve the input

THIS PAGE INTENTIONALLY BLANK

035-18685 SHT 1
REV C

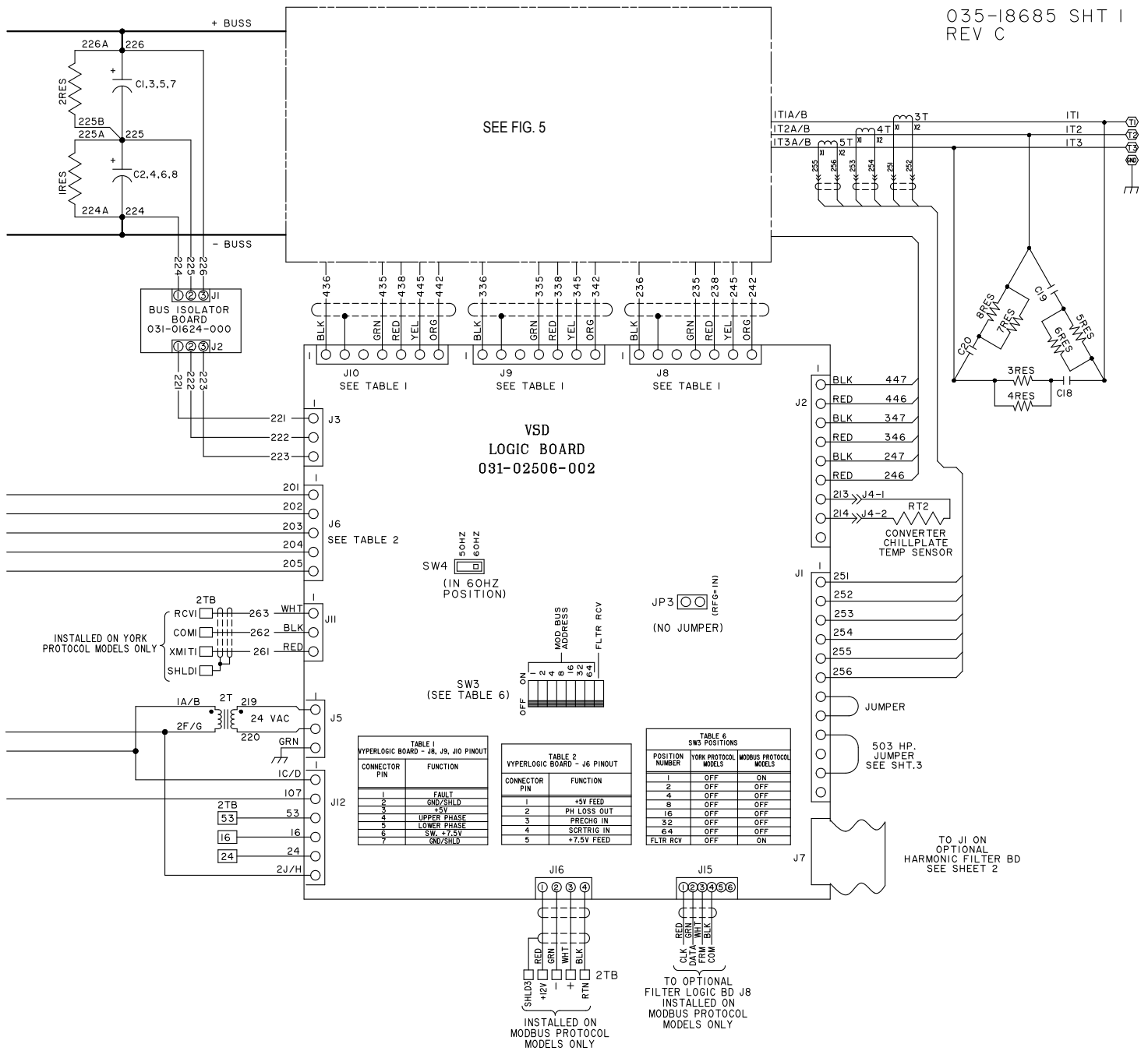

FIG. 3 (CONT'D) - ELEMENTARY WIRING DIAGRAM 419/503 HP

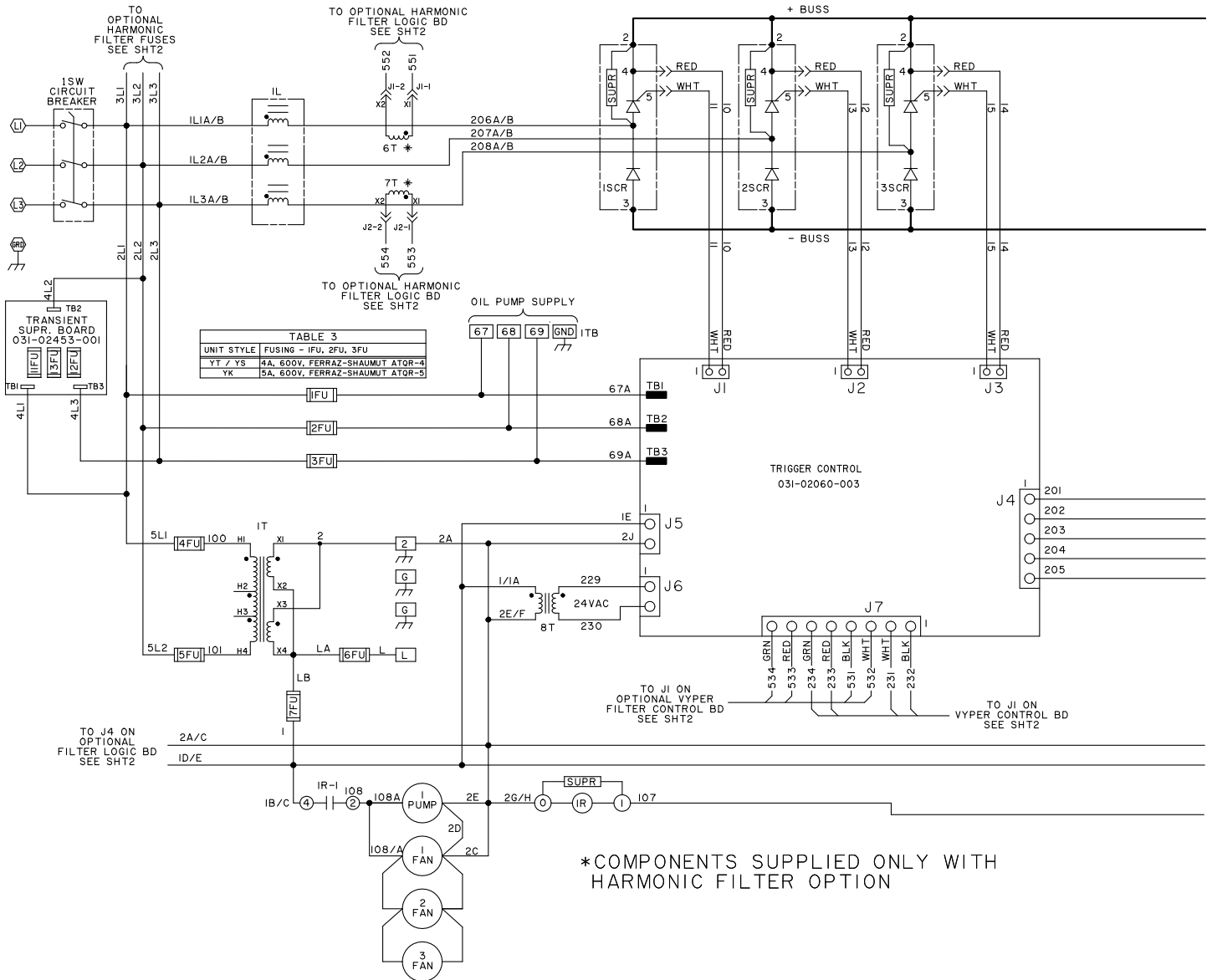

FIG. 4 – ELEMENTARY WIRING DIAGRAM 608 HP

LD13107

035-21016 SHT 1
REV C

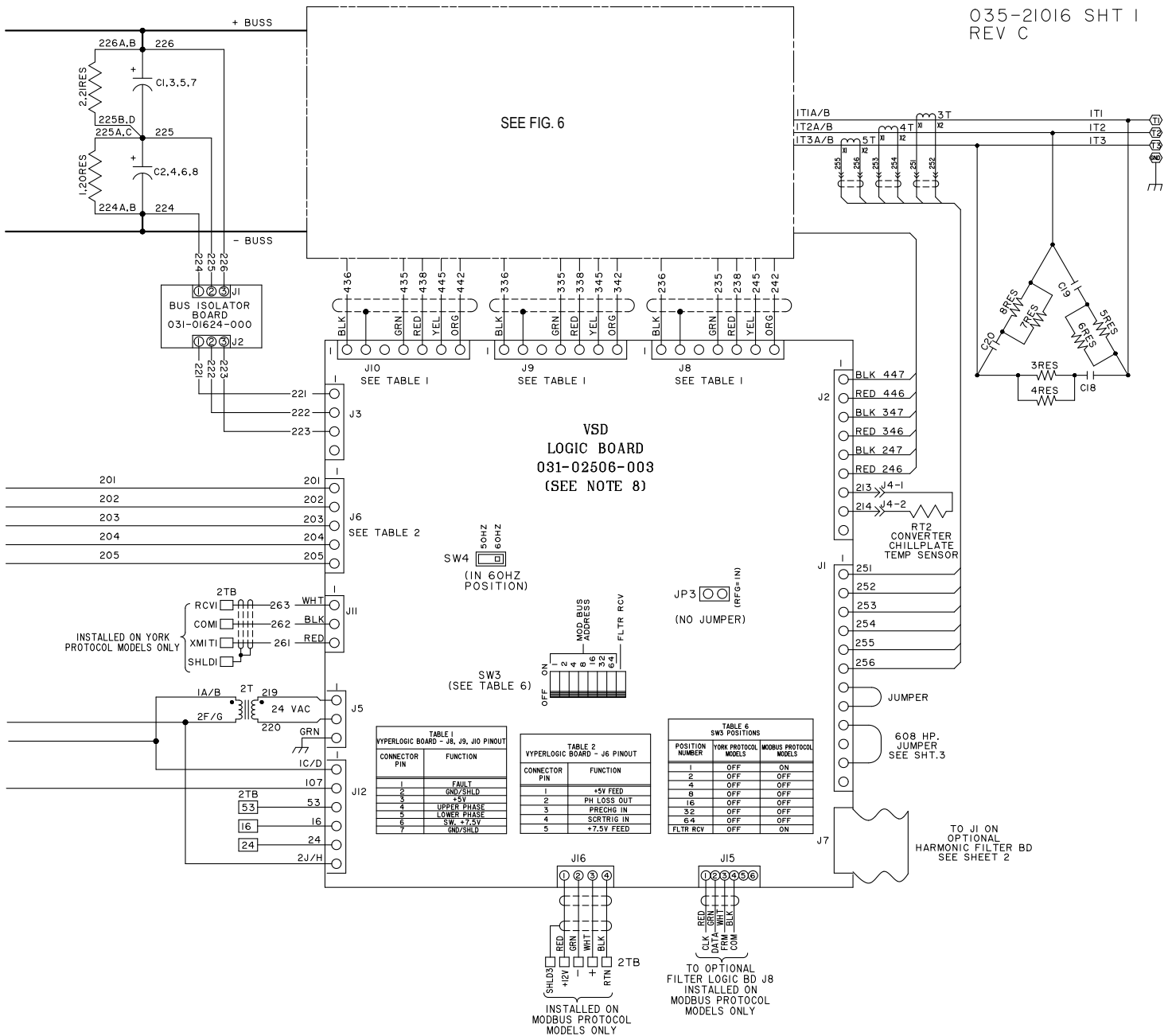

FIG. 4 (CONT'D) - ELEMENTARY WIRING DIAGRAM 608 HP

035-18685 SHT 2
REV C

POWER ASSY ELEMENTARY

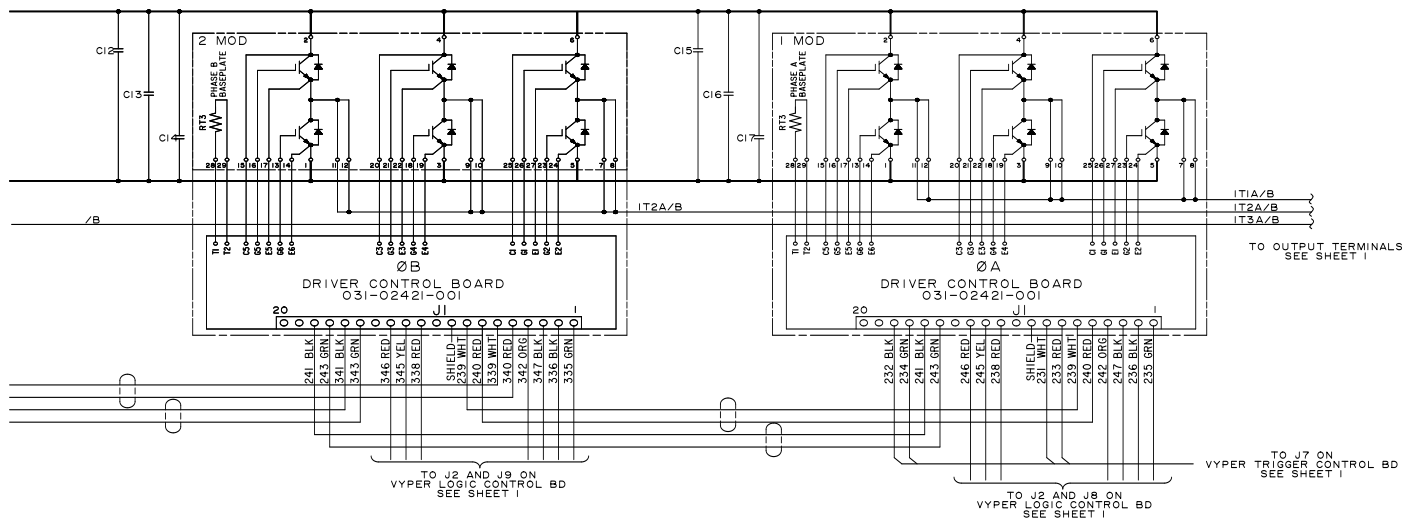

FIG. 5 (CONT'D)– POWER ASSEMBLY ELEMENTARY WIRING DIAGRAM 419/503 HP

LD13106B

POWER ASSY ELEMENTARY

035-21016 SHT 2
REV C

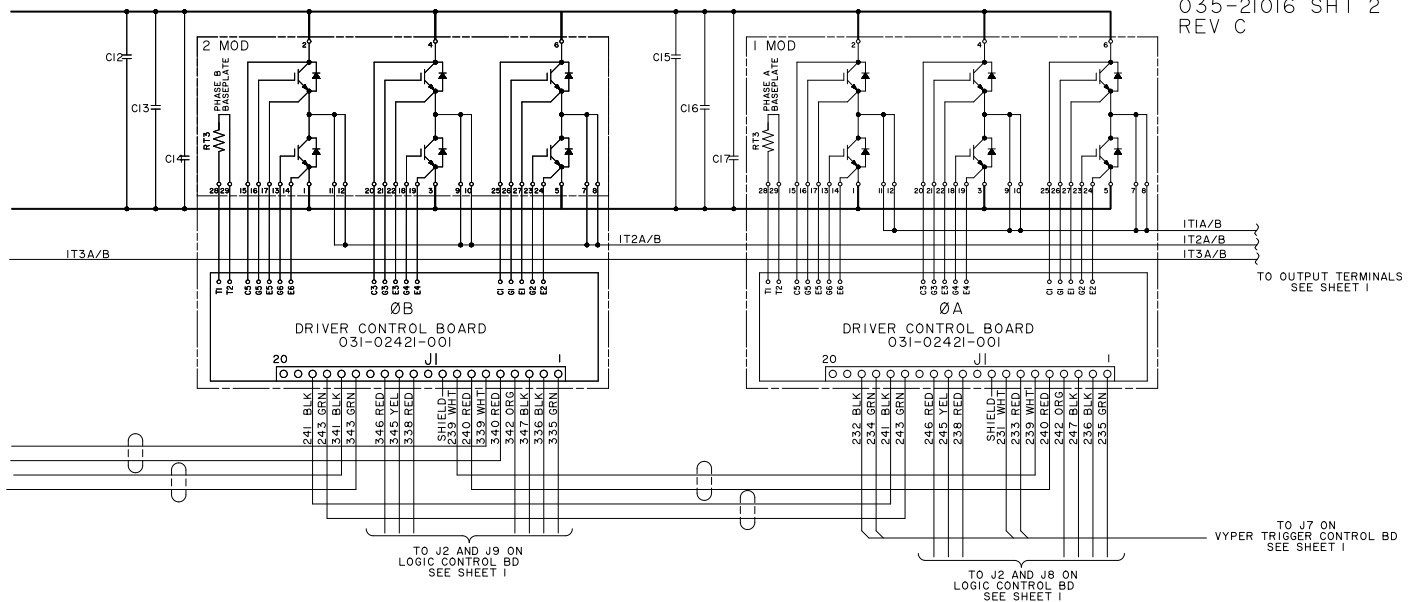

FIG. 6 (CONT'D) – POWER ASSEMBLY ELEMENTARY WIRING DIAGRAM 608 HP

LD13109B

current waveform drawn by the OSCD from the AC line, thus reducing the possibility of causing electrical interference with other sensitive electronic equipment connected to the same power source.

Fig. 7A is a typical input current waveform for the OSCD system without the optional harmonic filter when the system is operating at 50% load. Fig. 7B is a typical input current waveform for the OSCD system with the optional harmonic filter installed when operating at the same load conditions. The waveforms show that the input current waveform is converted from a near square waveform to a fairly sinusoidal waveform when the harmonic filter is installed. In addition, the power factor of the system with the harmonic filter installed corrects the system power factor to nearly unity.

Harmonic Filter Option 292, 351 & 424 Hp

The power section of the Harmonic Filter is composed of three major blocks: a pre-charge section, a three-phase inductor and a Filter Power Unit. The following description of operation is specific for the 351 Hp OSCD unless otherwise noted. (see Fig. 8).

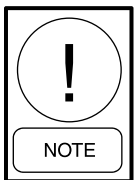

The figures for all horsepower harmonic filters are included in this form, but the component identifications are specific for the 351 horsepower drive.

The pre-charge section is formed by three resistors (9RES - 11RES), and two contactors, pre-charge contactor 1M and supply contactor 2M. The pre-charge network serves two purposes, to slowly charge the DC link filter capacitors associated with the Filter Power Unit (via the diodes within the IGBT module 2MOD) and to provide a means of disconnecting the filter power unit from the AC line. When the chiller is turned off, both contactors are de-energized and the filter power unit is disconnected from the AC line. When the chiller starts to run, the pre-charge resistors are switched into the circuit via contactor 1M for a fixed time period of 5 seconds. This permits the filter capacitors in the filter power unit to slowly charge. After the 5-second time period, the supply contactor is energized, and the pre-charge contactor is de-energized, permitting the filter power unit to completely charge to the peak of the input power voltage. Three power fuses (8FU - 10FU) connect the filter power components to the AC line. Very fast

semiconductor power fuses are utilized to ensure that the IGBT module does not rupture if a catastrophic failure were to occur on the DC link of the filter power unit.

The three phase inductor (2L) provides some impedance for the filter to “work against”. It effectively limits the rate of change in current at the input to the filter to a reasonable level.

The Filter Power Unit is the most complicated power component in the optional filter. Its purpose is to generate the harmonic currents required by the OSCD’s AC-to-DC converter so that these harmonic currents are not drawn from the AC line. The Filter Power Unit is identical to the OSCD’s Power Unit in the 351 Hp drive, except for 2 less capacitors in the filter capacitor “bank” (C13-C16), a smaller IGBT module (2MOD) mounted to a direct liquid cooled heatsink, and a Harmonic Filter Gate Driver board (031-02061-002).

The Harmonic Filter Gate Driver board provides turn on, and turn off commands to the IGBT module as determined by the Harmonic Filter Logic board. In order to assure an equal sharing of the voltage between the series connected capacitors on the Filter Power Unit, “bleeder” resistors 12RES and 13RES are connected across the cap bank. The “Bleeder” resistors are mounted on the side of the Filter Power Unit to provide a discharge path for the DC Link filter capacitors. In order to counteract the parasitic inductances in the mechanical structure of the Filter Power Unit, the filter incorporates “laminated bus” technology and a series of small film capacitors (C23-C25). The “laminated bus” technology used is identical to that used in the OSCD’s DC to AC inverter section of the drive.

Other sensors and boards are used to convey information back to the Filter Logic Board, and provide safe operation of the harmonic filter. The IGBT module contains a thermistor temperature sensor (RT3) that provides temperature information back to the Filter Logic Board via the Harmonic Filter Gate Driver Board. This sensor protects the Filter IGBT module from over temperature conditions. DC Current Transformers DCCT1 and DCCT2 sense the current generated by the optional filter. These two sensors are used to protect against a filter over current, or a filter overload condition. Current Transformers 6T and 7T sense the input current drawn by the OSCD’s AC to DC converter. These two CT’s are no longer present in the standard OSCD.

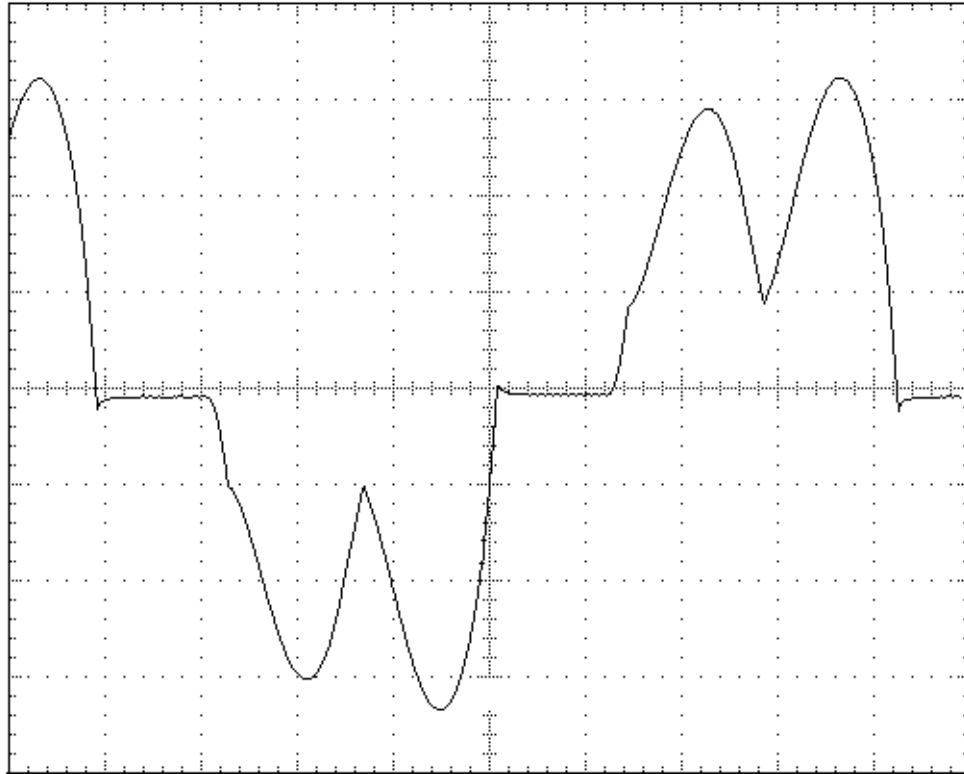

LD07407

FIG. 7A – VSD INPUT CURRENT WITHOUT FILTER

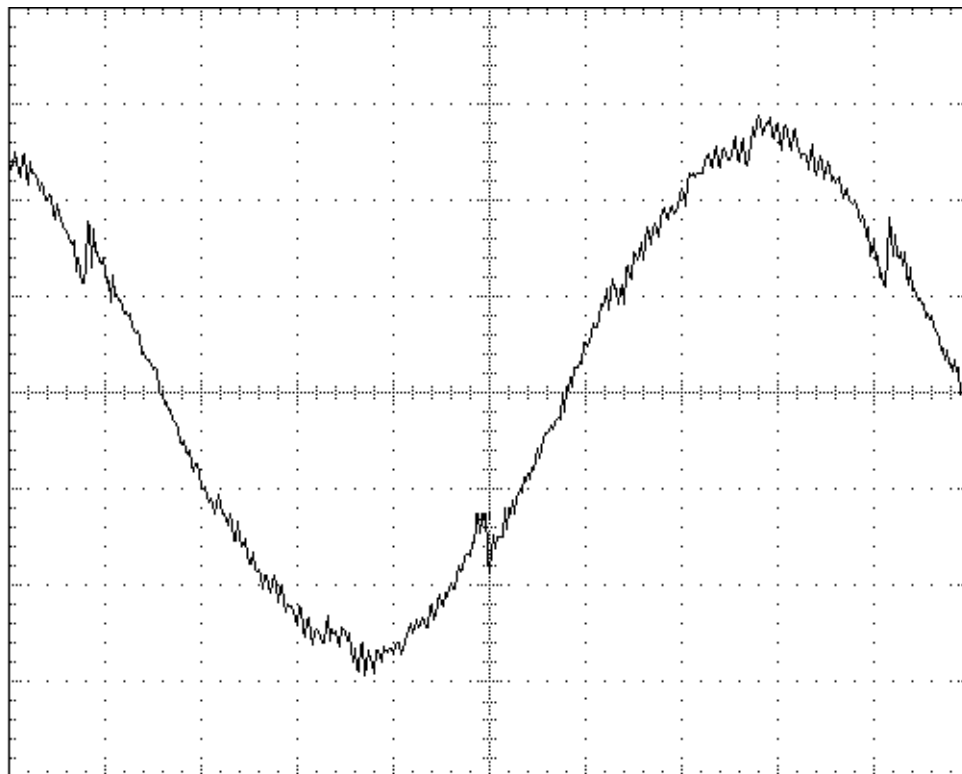

LD07408

FIG. 7B – VSD INPUT CURRENT WITH FILTER

HARMONIC FILTER ELEMENTARY DIAGRAM

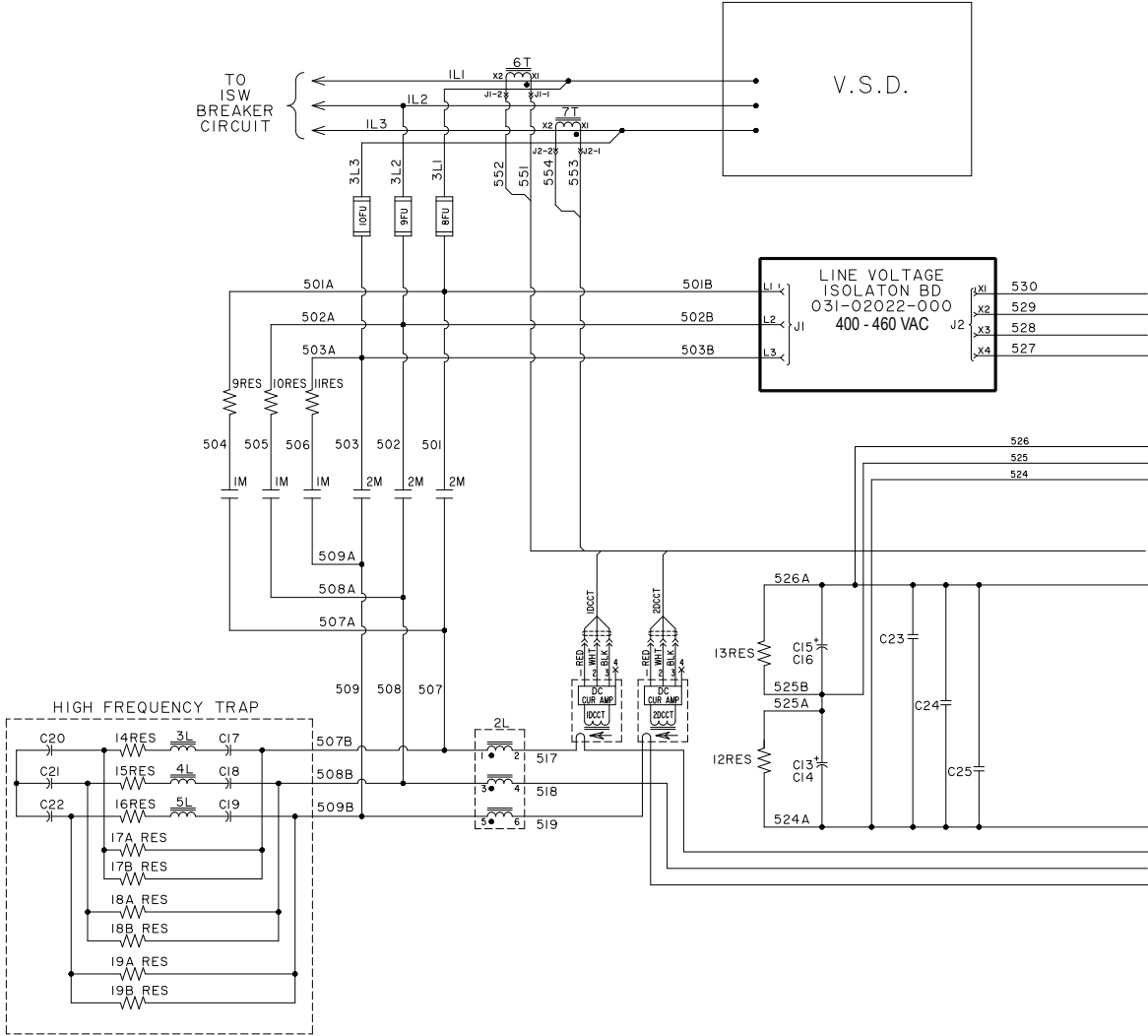

FIG. 8 – HARMONIC FILTER ELEMENTARY WIRING DIAGRAM 292 & 351 HP

LD13110

HARMONIC FILTER ELEMENTARY DIAGRAM

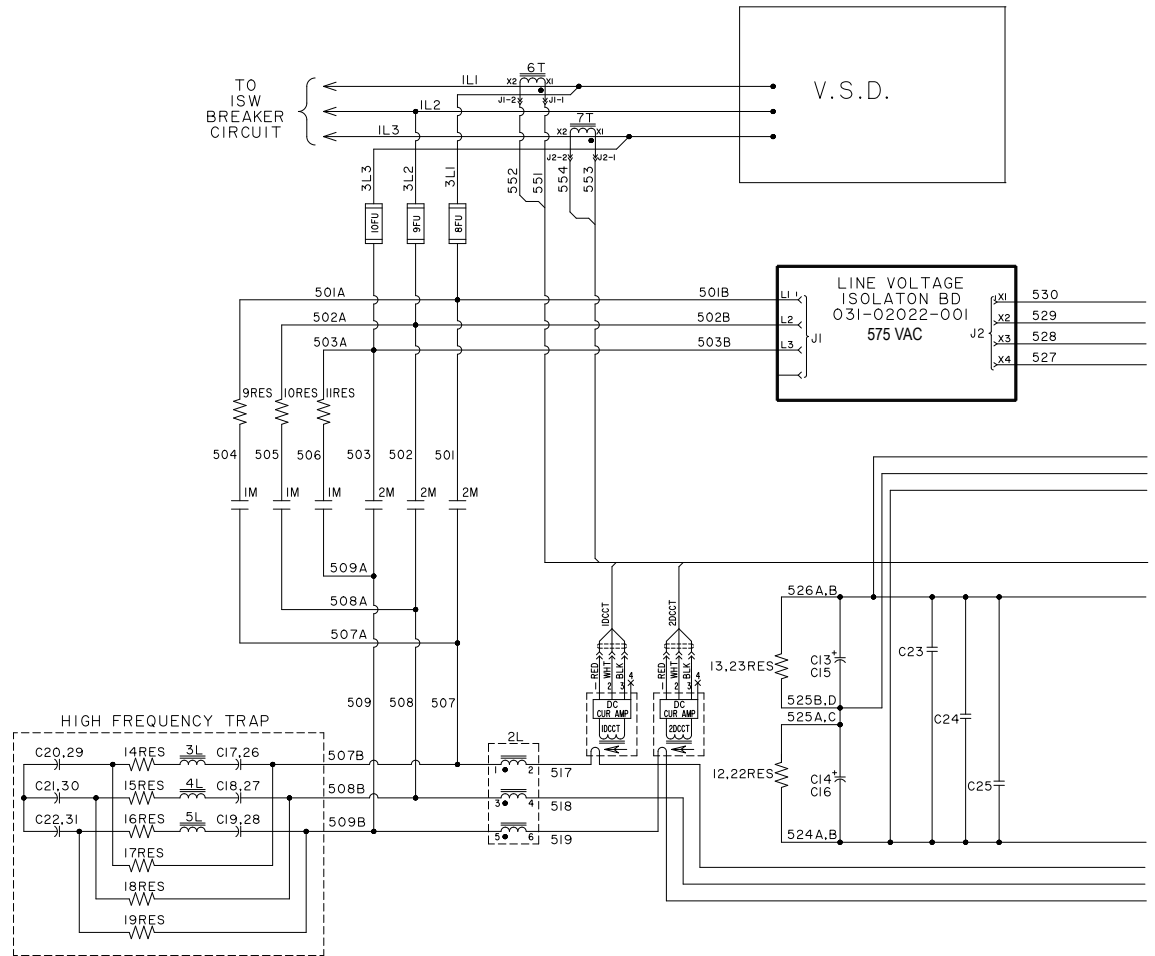

FIG. 9 – HARMONIC FILTER ELEMENTARY WIRING DIAGRAM 424 HP

LD13112

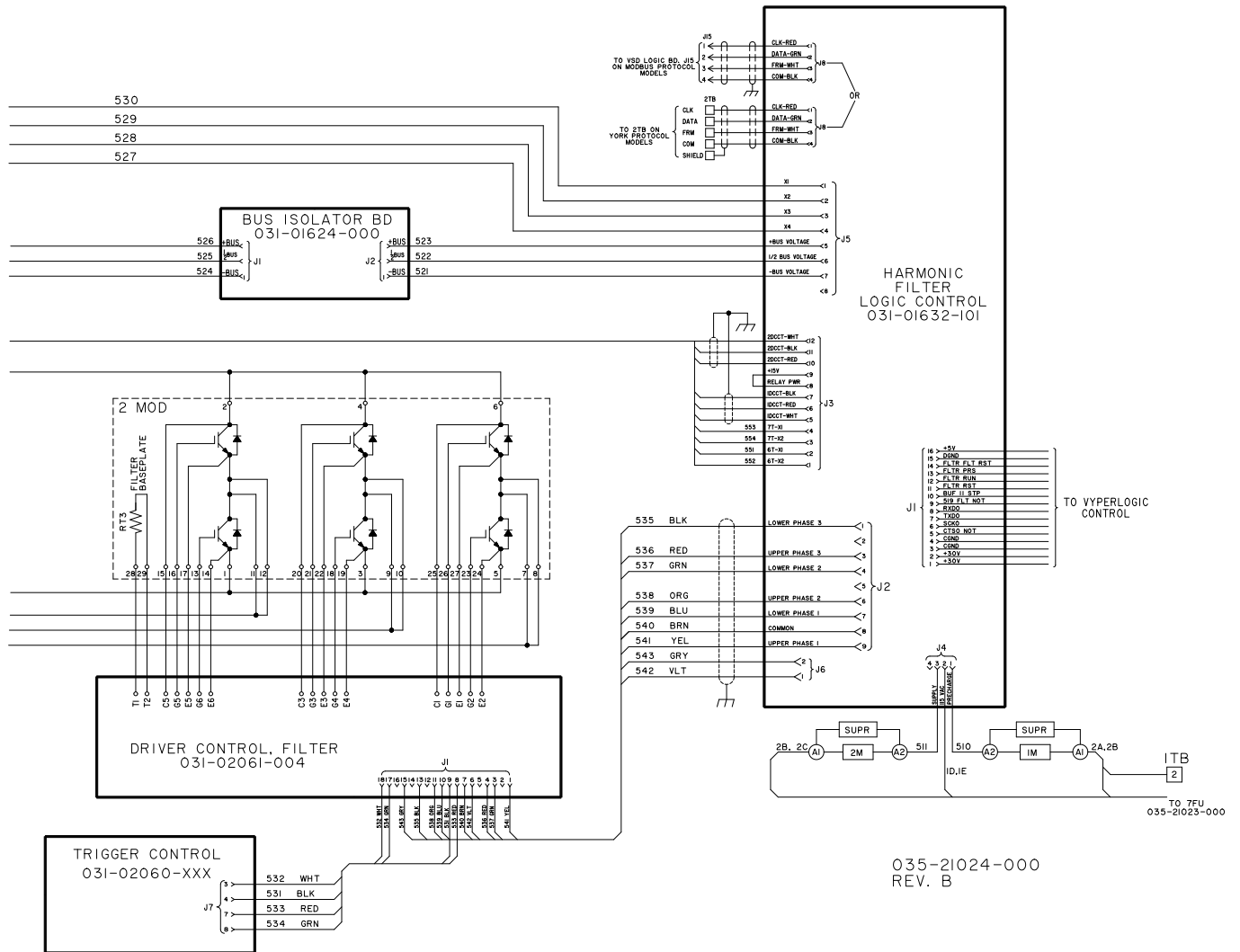

FIG. 9 (CONT'D)- HARMONIC FILTER ELEMENTARY WIRING DIAGRAM 424 HP

The Line Voltage Isolation board (031-02022-000 400 & 460 VAC input, 031-02022-001 575 VAC input) provides AC line voltage information. This board steps the line voltage down to a safe level and provides isolation to the Filter Logic board. This information is used to determine a low bus voltage condition, and what the proper bus voltage should be. The Bus Isolation board (031-01624) incorporates three resistors to provide a “safe” impedance between the DC filter capacitors located in the Filter Power Unit and the Filter Logic Board. It provides the means to sense the positive, midpoint and negative connection points of the filter’s DC link. This information is used to determine bus voltage imbalance, high bus voltage, and low bus voltage shut downs.

The “trap” filter is standard on all OSCD that contain the optional Harmonic Filter. The “trap” filter is composed of a series of capacitors (C17-C22), inductors (3L-5L) and resistors (14RES-19RES). The “trap” filter acts as a low resistance for a range of frequencies centered at the switching frequency of the filter. The purpose of the trap is to block currents at the switching frequency of the harmonic filter from getting onto the power mains.

Harmonic Filter Option 419, 503 & 608 HP

The 419, 503 and 608 Hp harmonic filter functions in the same manner as the 351 Hp and have the many of the same components, but more of them. The power requirements of these higher horse power drives require more capacitors in the DC Link, and a higher current rated IGBT module is needed. The IGBT module contains a thermistor, and it is connected to the harmonic filter logic board. The IGBT gate driver board is mounted on top of the IGBT module as in the 351 Hp. The modules and the boards are not interchangeable between the different horsepower drives.

575 VAC Harmonic Filter Differences From 460 VAC Harmonic Filter

The 424 and 608 Horsepower harmonic filters are 575 VAC versions of the 460 VAC 351 and 503 Hp harmonic filters. A few changes to the OSCD are required.

First, the input IGBT’s voltage rating is increased as well as the voltage rating for the Bus caps. The harmonic filter logic is change to accommodate the higher bus voltage and changes in carrier frequency. The trap assembly has changed because of the changes in the carrier frequency for the harmonic filter. More bleeder resistors of a higher resistance value are required to support the higher bus voltage.

Form 160.00-RP4 contains all of the different part number required for these products. **It is very important not to mix parts between different voltage ranged OSCD.**

THIS PAGE INTENTIONALLY BLANK

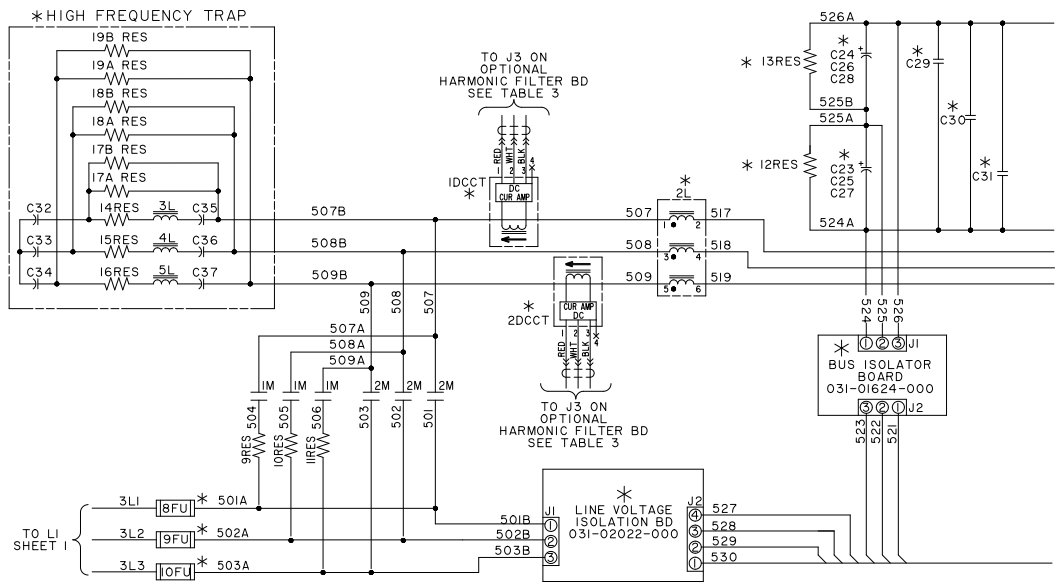

FIG. 10 – HARMONIC FILTER WIRING DIAGRAM 419 & 503 HP

LD13116

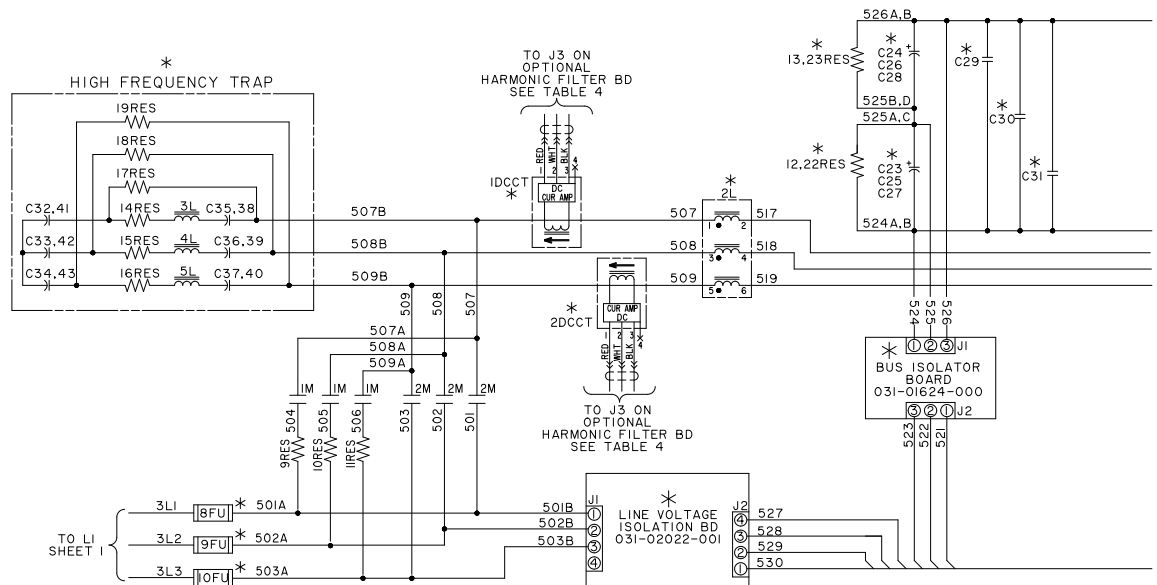

FIG. 11 – HARMONIC FILTER WIRING DIAGRAM 608 HP

LD13114

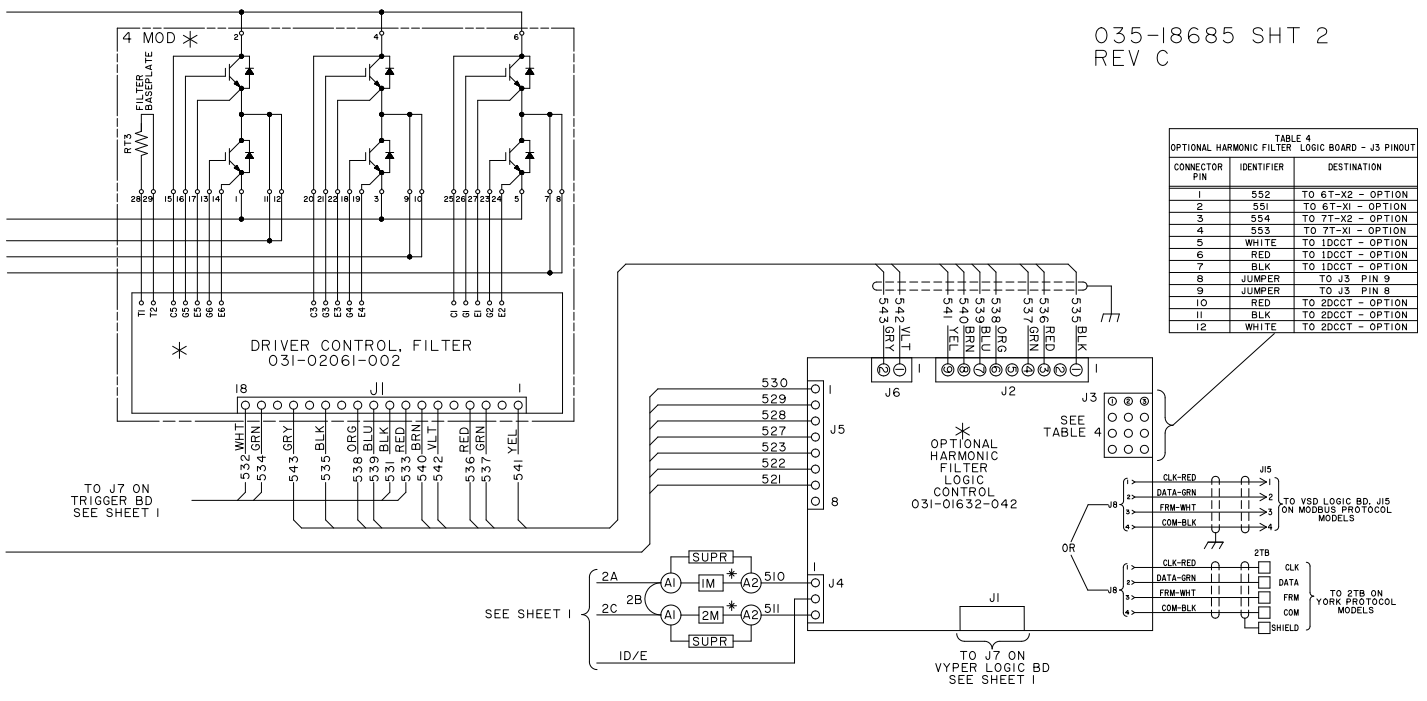

FIG. 10 (CONT'D)- HARMONIC FILTER WIRING DIAGRAM 419 & 503 HP

LD13117

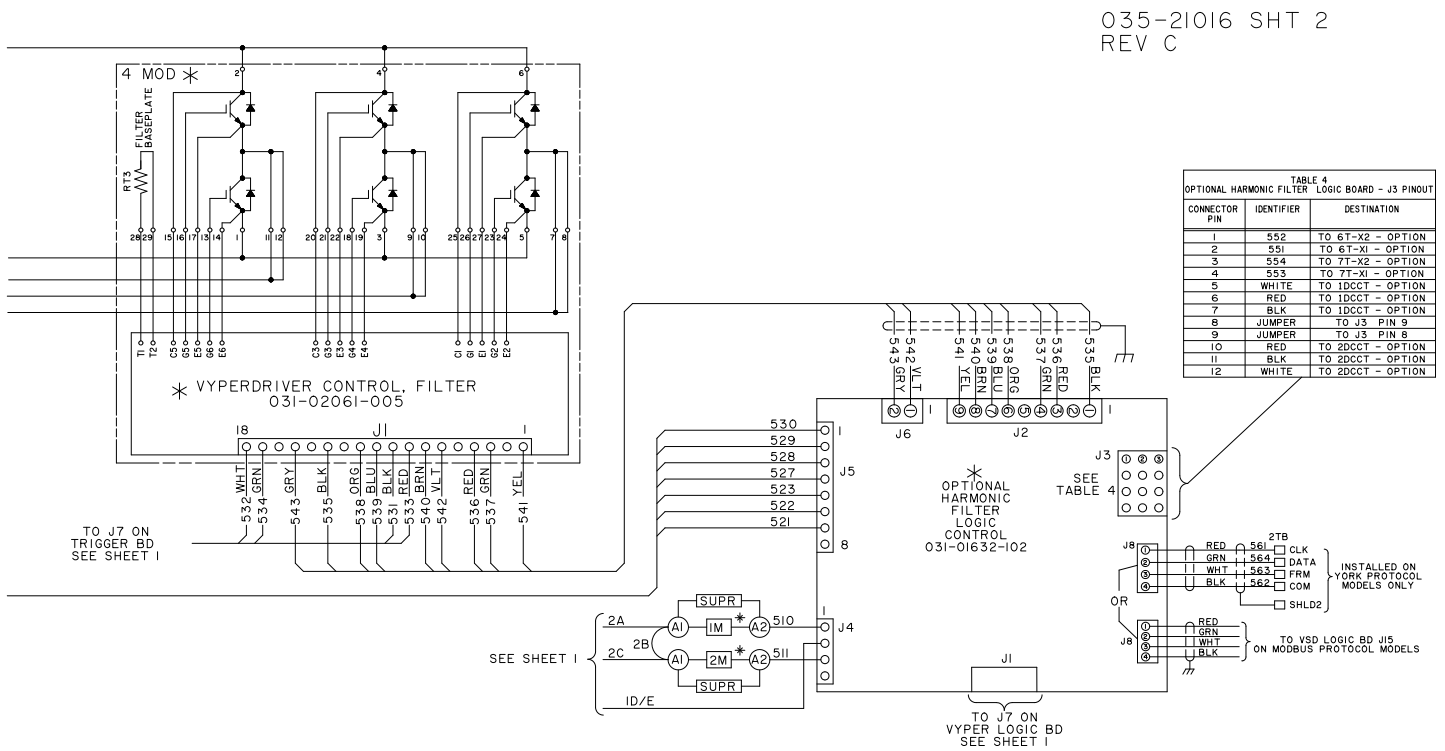

FIG. 11 (CONT'D)- HARMONIC FILTER WIRING DIAGRAM 608 HP

LD13115

OPTISPEED COMPRESSOR DRIVE CONTROL SYSTEM OVERVIEW

The OSCD control system can be connected to a Microcomputer Control Center or to an OptiView Control Center. Regardless of which control center is used each component performs the same function.

The OSCD control system is composed of various components located within both the Control Center and the OSCD. Thus integrating the Control Center with the OSCD. The OSCD system utilizes various microprocessors and Digital Signal Processors (DSPs) which are linked together through a network of parallel and serial communications links.

The Control Center

The Control Center contains two boards that act upon OSCD related information, the Microboard and the Adaptive Capacity Control board (ACC). The ACC board performs two major functions in the OSCD control system - (1) to act as a gateway for information flow between the Control Center and the OSCD. (2) To determine the optimum operating speed for maximum chiller system efficiency.

The ACC board acts as an information gateway for all data flowing between the OSCD and the Control Center. The ACC board communicates via a bi-directional serial port with the OSCD logic board (via J8 on the ACC board) and uni-directional serial port from the optional Filter logic board (via J9 on the ACC board) using a pair of shielded cables. Once the information is received by the ACC board, the information is then passed onto the Control Center via a software communication link. The Microcomputer Control Center communicates in a parallel fashion via two ribbon cables connecting the ACC board to the Microboard (J1 and J2 on the ACC board, Fig. 13). The OptiView Control Center communicates through a bi-directional serial port via a three wire shielded cable connecting the ACC board to the Microboard (J10 on the ACC board, Fig. 12).

In order to achieve the most efficient operation of a centrifugal compressor, the speed of the compressor must be reduced to match the “lift” or “head” of the load. This “lift” or “head” is determined by the evaporator and condenser refrigerant pressures. However, if the compressor speed is reduced too much, the refrigerant gas will flow backwards through the compressor wheel causing the compressor to “surge”, an undesirable and extremely inefficient operating condition. Thus there exists one particular optimum operating speed (on the “edge” of surge) for a given head, which provides the optimum system efficiency. The compressor’s inlet

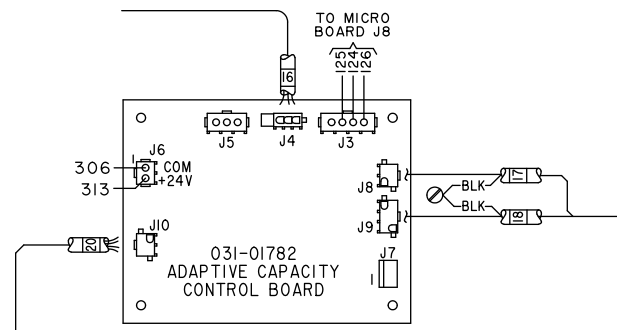

LD13118a

FIG. 12 – ADAPTIVE CAPACITY CONTROL BOARD FOR OPTIVIEW CONTROL CENTER

guide vanes, which are used in fixed speed applications to control the amount of refrigerant gas flowing through the compressor, are controlled together with the compressor speed on an OSCD chiller system, to obtain the required chilled water temperature while simultaneously requiring minimum power from the AC line.

The ACC board automatically generates its own “Adaptive” three-dimensional surge surface map while the chiller system is in operation. This “Adaptive” operation is accomplished through the use of a patented surge detection algorithm. The novel surge detection system utilizes pressure information obtained from the chiller’s two pressure transducers or the OSCD’s instantaneous power output to determine if the system is in “surge”. Thus the adaptive system permits construction of a customized compressor map for each individual chiller system.

Benefits of this new adaptive system include: (1) a customized compressor map for each chiller which eliminates inefficient operation due to the safety margin built into the previous designs to compensate for compressor manufacturing tolerances (2) the ability to update the system’s surge surface as the unit ages and (3) automatic updating of the compressor map if changes in refrigerant are implemented at a later date.

OptiSpeed Drive Logic Control Board

Within the OSCD enclosure, the OSCD logic board and optional Filter logic board are interconnected via a 16-position ribbon cable. The Filter Logic board derives its control power from the OSCD Logic board over this ribbon cable. In addition, various logic level “handshake” signals convey the operating status of the OSCD to the Filter and vice versa over this cable. Finally, the cable includes a unidirectional serial

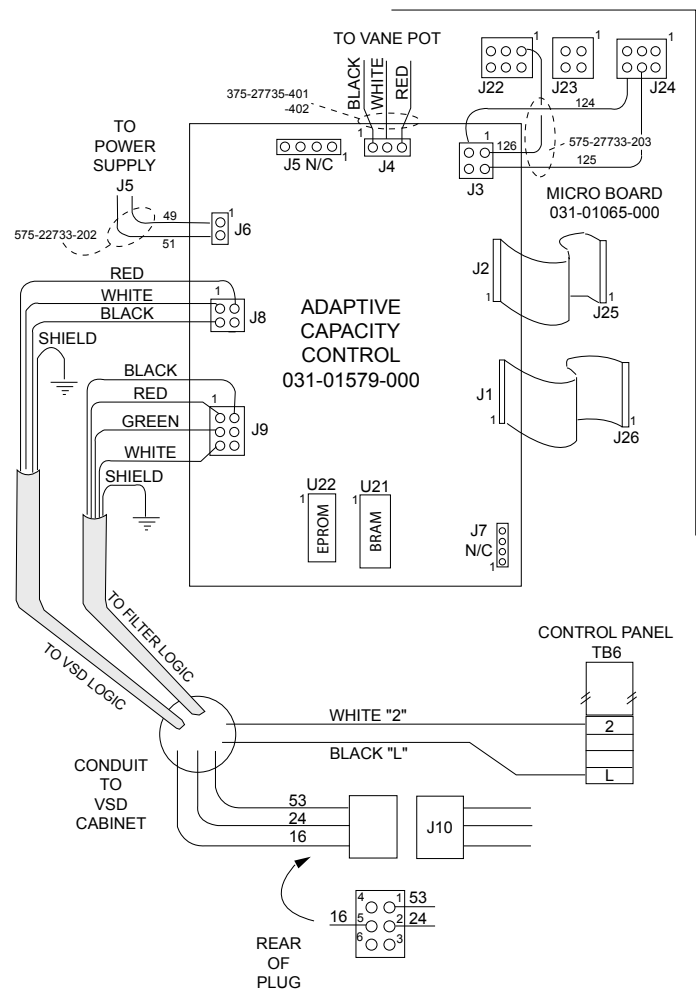

LD03405a

FIG. 13 – ADAPTIVE CAPACITY CONTROL BOARD

communications link, which permits the transmission of a limited amount of data, such as the run command, from the OSCD to the optional Harmonic Filter.

The OSCD Logic board performs numerous functions, control of the OSCD's cooling fans and pumps, when to pre-charge the bus capacitors, and generates the PWM.

- The cooling fans and pumps are commanded to turn on whenever the OSCD is commanded to run. They will turn off when the drive is commanded to stop. If the OSCD is shutdown due to a high-temperature condition, then the fans and pumps will continue to run until the value of the high-temperature has dropped below a specified value. The cooling fans and pumps will also run if the J2 connector is removed.

- The OSCD Logic board sends a command signal to the SCR gate driver board to precharge the bus capacitors. For pre-charge to become active J6 Pin 3 must be low, and J6 Pin 5 must be at 7.5 VDC.
- The PWM generation is required so that the output of the OSCD will provide to the motor the proper voltage for a given output frequency. The PWM generation is sent to the IGBT gate driver board via J8, J9, and J10.

The OSCD Logic board also determines shutdown conditions by monitoring the three phases of motor current, heatsink temperature, baseplate temperature, internal ambient temperature, and the DC Link voltage.

- The output motor current is monitored by the current transformers mounted in the center of the drive. They are connected to the OSCD logic board on J6.

- The heatsink temperature is monitored by a thermistor mounted on the same side of the chill plate as the SCR/Diode blocks. This sensor is connected to the OSCD logic board on J2.
- The baseplate temperature is monitored by a thermistor mounted inside the IGBT module. Each IGBT module in the 503 Hp drive has a thermistor. Any one of the 3 thermistors can cause an over temperature fault. They are connected to the OSCD logic board via the IGBT gate drive board and then onto J2.
- The internal ambient temperature is monitored by a thermistor mounted on the OSCD Logic board.
- The DC Bus voltage is monitored by the DC link isolator board. It is connected to the OSCD logic board on J3.

- The filter current is monitored by the DC current transformers mounted between the wires to filter inductor and the filter's IGBT module. They are connected to the filter logic board on J3 pins 5-7 and 10-12.
- The baseplate temperature is monitored by a thermistor mounted inside the harmonic filter IGBT module. This sensor is connected to the filter logic board via the IGBT gate drive board and then onto J6 pins 1 and 2.
- The input voltage is monitored by the AC line voltage isolator board and is connected to the filter logic board on J5 pins 1-4. Measuring AC voltage from pins 1-2, 2-3, 3-1, should have a value of 5.2 VAC with a 460 VAC line voltage.
- The DC Bus voltage is monitored by the DC link isolator board. It is connected to the filter logic board on J5 pins 5-7.

OptiSpeed Harmonic Filter Logic Control Board

The optional Harmonic Filter logic board determines when to precharge the filter power unit, when to switch the IGBT's in the filter power unit, and collects data to determine power calculations. Data such as input line voltage, filter DC bus voltage, output current of the filter power unit, and temperature of the filter power unit IGBT's are collected and sent to the Control Center. This data is also used by the filter logic board to determine if a shutdown is required.

- The Harmonic Filter Logic board sends a command signal to the pre-charge contactor to become active J4 Pin 1 must be 115 VAC
- The Harmonic Filter Logic board sends a command signal to the supply contactor to become active J4 Pin 3 must be 115 VAC
- It turns on and off the Harmonic Filter IGBT's via J2
- It sends communications to the ACC board via J8.

The Harmonic Filter Logic board also determines shutdown conditions by monitoring the two phases of input current, two phases of filter output current, baseplate temperature of the harmonic filter IGBT, input line voltage, and the DC Link voltage.

- The input current is monitored by the current transformers mounted near the filter inductor. They are connected to the filter logic board on J3 pins 1-4.

Microcomputer Control Panel VSD Related Keypad Functions

Refer to 160.00-M1 for related keypad functions. Some of the displayed data in this form is different from the 160.00-M1.

Under the Options Key – the following changes will be displayed:

VSD PHASE A INVERTER HEATSINK TEMP = ___ °F.

VSD PHASE B INVERTER HEATSINK TEMP = ___ °F.

VSD PHASE C INVERTER HEATSINK TEMP = ___ °F.

These three temperature values are replaced with:

VSD BASEPLATE TEMP = ___ °F

for the 292, 351 and 424 Hp drive. The 419, 503 and 608 Hp drive will still display 3 phases of Baseplate temperature. When the Filter is present the following data will be changed.

FILTER HEATSINK TEMP = ___ °F.

This temperature data will now be called.

FILTER BASEPLATE TEMP = ___ °F.

The names for the above data were changed because the temperature sensor is now inside the IGBT module instead on the chill plate where the IGBT's are mounted. This new sensor gives a better indication of true temperature of the IGBT module.

OptiView Control Panel VSD Functions

Refer to the specific OptiViewControl Panel service book for detailed information. All of the OSCD

related information is contained under the Motor and Compressor Screens.

VSD ADAPTIVE CAPACITY CONTROL

The YORK OptiSpeed Compressor Drive utilizes a different approach to speed reduction compared to earlier variable speed products. There is no pre-programmed surge map – the YORK adaptive system experiments with the speed and vanes to find the optimum speed for any given condition. It does not always encounter a “Surge” in the process, but when it does, the Adaptive Capacity Control (ACC) stores into memory, the conditions surrounding the Surge, and therefore remembers to avoid the stored operating point anytime in the future. This sounds a bit mysterious, but the process is really quite simple. Once you have an understanding of the steps involved, you will be able to watch the chiller adjust itself to different conditions, and understand exactly why it is performing in the manner it does.

Early versions of the ACC software required that the drive always start and run up to full speed. ACC software starting with version C.ACC.01.04 applies a slow ramp up of the drive speed. This new software lowers the peak current demand from the drive during start up, saves additional energy, and reduces the possibility of the chiller running in a stall condition.

The new software will ramp the drive speed up to 30 Hz quickly, and then takes 5 minutes to ramp up to 60 Hz. During this slow ramp up period the vanes will open to meet the cooling demand. If the leaving chilled liquid temperature is within +0.5 or lower of the leaving chilled liquid temperature setpoint, then the drive speed will stop increasing and start to search for a surge map point. On extremely hot days the chiller will surge during the slow ramp period. The new software has a method to limit the surging. If 2 surges were to occur during the slow ramp period, then the speed of the drive will increase quickly to 60 Hz.

All versions of software require that two conditions be met for speed reduction to occur. These two conditions are:

Setpoint Requirements

The leaving chilled liquid temperature must be within +0.5 °F or lower from the leaving chilled liquid temperature setpoint. Speed reduction will not occur

until the leaving chilled liquid temperature reaches this range.

Stability Requirements

The leaving chilled liquid temperature must be stable, with the vanes not driving open or closed to maintain the temperature. Lack of stability will be evidenced by the vanes hunting, the leaving chilled liquid temperature varying, and the green LED on the ACC board will be on, to indicate instability. Once the above conditions are met, the ACC board may begin to lower the speed of the compressor motor 1/10 of a hertz at a time. As the ACC board lowers the speed, the leaving chilled liquid temperature will begin to creep up, due to the reduction in speed. As this occurs, the control center will begin to open the vanes slightly, just enough to maintain the leaving chilled liquid temperature within +/- 0.5°F of the leaving chilled liquid temperature setpoint. The ACC board will continue to lower speed, with the leaving chilled liquid temperature control in turn driving the vanes to a more open position. This process will continue until one of three following situations occurs.

Full Open Vane Operation

Once the vanes reach the full open position, the ACC board knows it can no longer reduce speed and maintain the leaving chilled liquid temperature setpoint. The ACC board will maintain operation at this point, with the vanes full open, and the speed at the last point reached when the vanes hit 100%. If there is an increase in load while at this point, the ACC board will increase speed until the vanes are closed to 95% of open. The ACC board will then be allowed to continue to reduce speed again.

Effects of Surge

If in the process of reducing speed and opening vanes the compressor should surge, the ACC board will boost the speed up by 0.8 Hz. The ACC board will store in memory a value that is (condenser pressure/evaporator pressure) - 1, the vane position present at the time of the surge, and the speed of the drive. The value for (condenser pressure/evaporator pressure) - 1 is displayed as Delta P/P on the Control Panel. The ACC board will then know

not to reduce speed this low again, if the same delta pressure, and the vane position conditions are encountered again in the future. As the chiller encounters more delta pressure and vane position combinations, which result in surge, it will store more points, and eventually this storing of points creates a “Surge Map”.

Surges may be detected in two ways, by monitoring the pressure differential across the compressor, or by monitoring the compressor motor current. Either detection will light the Red LED on the ACC board, indicating a surge was detected. The chiller may surge 6 to 8 times before the ACC board can raise the speed enough to get the chiller back out of surge. Each surge is counted on the surge counter, which may be called up on the control center. This surge counter will always display the total number of surges encountered by the chiller as determined by the ACC board, but not the total number of points contained in the surge map.

Surging which occurs at fixed speed will increment the surge counter as well, but only surges that occur when speed reduction is possible are recorded in the surge map. We know of one chiller, which ran in continuous surge for two weeks due to a cooling tower problem. The customer's fixed speed chiller was surging continuously for 2 weeks also. During this time, the VSD surge counter accumulated over 18,000 surges.

Drive not Slowing Down

The ACC board may begin the process of reducing speed, but may stop speed reduction prematurely if instability is encountered. This is the same instability discussed as one of the two conditions which must be met to begin reducing speed initially (See “Stability Requirements”). Once the system again becomes unstable, no additional speed reduction can occur. The most common causes for instability are:

- Rapid changes to chilled or condenser liquid flow. (Variable speed pumps may not work well)
- Valves on air-handler coils closing rapidly causes changes in heat-load.
- Extremely short chilled liquid loop.
- Parallel chiller with poor control is causing temperature variations.
- Parallel chiller with poor control of chilled or condenser water flows.
- Dirty condenser tubes or high condenser liquid temperature.
- Chillers with very light loads.
- Liquid level control not working properly.

If you experience a problem with an OSCD not reducing speed at all, make certain the system is not in manual speed control, or locked into fixed speed. Refer to the section on “Manual Speed Control” in the “Frequently Asked Questions” section. Also, make certain the wiring at J3 on the ACC board is properly connected per the wiring diagram in this same manual. Either situation will cause the chiller to maintain full speed. If the OSCD is reducing speed, but not running as slow as you expect it should, it is likely because it is either in an unstable condition, or running just above a mapped surge point.

As described above, the chiller must achieve stability, which is evidenced by the Green LED being extinguished. Instability will cause the Green LED to be illuminated. To determine if the chiller is running just above a surge point, switch the system to manual speed control, and force the speed lower by one or two hertz. If you encounter a surge, this explains why the chiller would not reduce speed. If you find the chiller does drop speed without surging, instability was likely preventing further speed reduction.

Drive does not respond to chiller surging

The ACC control uses information from the condenser and evaporator pressure transducers to determine if the chillers has surged. If the chiller is surging and the speed of the drive is not increasing, then the wiring to the ACC board on J3 should be verified. Many times where an OSCD is retrofitted to an existing chiller the wiring to J3 is forgotten. A few new chillers with OSCD's have the wiring to the J3 of the ACC or at the control center microboard wired incorrectly.

Stability Limit Adjustment

Stability Limit Adjustment allows the system to properly function with larger amounts of temperature instability. Refer to 160.55.M1, or 160.54.M1 for the location of this parameter. Stability Limit has a range of 1000-7000. Although the leaving chilled liquid temperature Setpoint Requirement is satisfied, the Stability Requirement must also be satisfied. When the Stability Limit is adjusted to a value of 1000, then the leaving chilled liquid temperature can not change more than 0.067°F/second. When the Stability Limit is adjusted to a value of 6999, the leaving chilled liquid temperature can not change more than 0.47°F/second. If you are having a problem with a lightly load chiller and the temperature is not stable, then adjust the Stability Limit to 7000. The value of 7000 will disable this parameter.

Surge Margin Adjustment

Surge Margin Adjustment allows the surge map to increase the frequency portion of the surge map. This parameter is rarely used, and it decreases the efficiency of the OSCD chiller system. Some people believe that this value can help with a stall condition. This is not true. Actually, increasing the Surge Margin Adjustment will cause the stall condition to be worse. Increasing the speed of the compressor will cause the vane to close even more and increase the stall noise and vibration.

Software Version Changes

- Software version C.ACC.01.03 improved the communications between the ACC board and the OSCD logic board.
- Software version C.ACC.01.03a made additional improvements to the communications between the ACC board and the OSCD logic board.
- Software version C.ACC.01.04 added a slow ramp when the chiller is started. This version requires that a pull-down demand limit be set to 80% for 5 minutes.
- Software version C.ACC.01.05 changes how the ACC control will detect a surge. This version is required for new compressor designs. This software is backwards compatible with older compressors as well.

SAFETY SHUTDOWNS

General Information

The Shutdowns are organized in alphabetical order based on the OptiView Control Center messages. The Microcomputer Control Center messages are also included under these headings.

Whenever a Safety Shutdown is generated by the OSCD or Harmonic Filter Logic Board, a series of events will occur.

- If the chiller is not running at the time of the shutdown, the OSCD Logic Board will not turn on the IGBT gate drivers.
- The K1 relay on the OSCD logic board will de-energize causing an open circuit between J12-3 wire #53 and J12-4 wire #16. This action will indicate to the Control Center that the OSCD has shutdown. The K1 relay will remain de-energized until the cause of the shutdown has been corrected.
- If the chiller is running at the time of the shutdown, the Control Center will start a coastdown period (150 seconds for centrifugal chillers).
 - The message “VSD Shutdown - Requesting Fault Data”...will be displayed when the Control Center is requesting the fault data from the OSCD.
 - The OSCD or Harmonic Filter Logic Board will send a shutdown code via the serial communications link to the ACC board and then to the Control Center. The Micro Board will interpret the shutdown code, and display a

shutdown message on the display of the Control Center.

After the coastdown period has timed out, the chiller may be restarted, if the shutdown is no longer active. Place the Compressor Switch in the Stop/Reset position, and then into the Start position and release. The chiller will start if no faults are active.

Motor or Starter – Current Imbalance

Message **Motor or Starter – Current Imbalance**

The OSCD logic board generates this shutdown. This shutdown will become active when the highest of the three motor currents exceeds 80% of the programmed FLA. After these conditions are met, if any one phase of motor current exceeds 30% of the average current for 45 seconds, a Safety shutdown will occur. Review the following example.

If

current in the A phase = 200A
 current in the B phase = 200A
 current in the C phase = 118A

Then

$$I_{AVE} = \frac{200 + 200 + 118}{3}$$

$$I_{AVE} = 173A$$

$$I_{ACCEPTABLE} = 173 * \pm 30\% = 121A, 225A$$

Therefore

Since phase “C” current = 118A which is less than the acceptable 121A, the chiller would shutdown if this imbalance exists for 45 seconds.

Possible Problems:

- Verify that all six of the gate driver LED’s are lit.
- Verify that the output CT’s are reading current correctly.

VSD - 105 % Motor Current Overload

Message: **105% Motor Current Overload**

The OSCD logic board generates this shutdown, by reading the current from the 3 output current transformers. The shutdown is generated when the OSCD logic board has detected that the highest of the three output phase currents has exceeded 105% of the programmed 100% full load amps (FLA) value for more than 40 seconds. The 100% FLA setpoint is determined by adjustment of the FLA trimpot on the OSCD logic board. This shutdown requires a manual reset via the Reset push-button on the OSCD logic board.

Possible Problems:

- FLA value not properly set for the application.
- High condenser pressure.
- Too much refrigerant in the chiller causing carry over.
- Refrigerant level sensor or system not working properly.

VSD - High Converter Heatsink Temperature

Message: **High Converter Heatsink Temp**

A thermistor sensor is positioned on the bottom of the copper chill plate where the SCR/Diode blocks are located. If at anytime this thermistor detects a temperature of 170°F (76°C) or higher a shutdown will occur. The cooling fans and coolant pump on the OSCD will continue to run after the shutdown, until the thermistor temperature has dropped to below 160°F (71°C). This shutdown requires a manual reset via the Reset push-button on the OSCD logic board.

Possible Problems:

- Improper coolant level for the drive.
- Leaks within the cooling system.

- Shipping coolant not drained at start-up.
- Clogged chill plate.
- Low condenser water flow.
- Dirty tube and shell heat exchanger.
- Failure of the coolant pump.
- Failure of a fuse for the coolant pump.

VSD - High Inverter Baseplate Temperature (292, 351, and 424 Hp drive only)

Message: **High Inverter Baseplate Temperature Flt**

A thermistor sensor is located inside the IGBT Module on the OSCD power unit. If at anytime this thermistor detects a temperature of 175°F (79°C) or higher a shutdown will occur. The cooling fans and coolant pump on the OSCD will continue to run after the shutdown, until the thermistor temperature has dropped to below 165°F (74°C). This shutdown requires a manual reset via the Reset push-button on the OSCD logic board.

Possible Problems:

- Improper coolant level for the drive.
- Shipping coolant not drained at start-up.
- Clogged chill plate.
- Low condenser water flow.
- Dirty tube and shell heat exchanger.
- Failure of the coolant pump.

VSD - High Phase (X) Inverter Baseplate Temperature (419, 503, and 608 Hp drive only)

Message: **High Phase (X) Baseplate Temperature Fault**

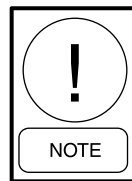

The X will indicate the phase that the high temperature has occurred.

A thermistor sensor is located inside the IGBT Module on the OSCD power unit. If at anytime this thermistor detects a temperature of 175°F (79°C) or higher a shutdown will occur. The cooling fans and coolant pump on the OSCD will continue to run after the shutdown, until the thermistor temperature has dropped to below 165°F (74°C). This shutdown requires a manual reset via the Reset push-button on the OSCD logic board.

Possible Problems:

- Improper coolant level for the drive.
- Shipping coolant not drained at start-up.
- Clogged chill plate.
- Low condenser water flow.
- Dirty tube and shell heat exchanger.
- No thermal grease used on the IGBT module.
- Failure of the coolant pump.
- Improper torque used during the mounting of the IGBT module.

- Low condenser water flow.
- Dirty tube and shell heat exchanger.
- Failure of the coolant pump.
- No thermal grease used on the IGBT module.

VSD - Precharge Lockout

Message: **Pre-charge Fault Lockout**

If the OSCD fails to meet the pre-charge criteria (refer to pre-charge faults), then the pre-charge circuit will wait for a period of 10 seconds. During which time the unit's cooling fans and coolant pump shall remain energized in order to cool the input SCR's. Following this 10-second cool-down period pre-charge shall again be initiated. The unit shall attempt to meet the pre-charge criteria three consecutive times. If the OSCD fails to meet the pre-charge criteria on three consecutive tries, the OSCD will shut down, lockout, and display this message. In order to initiate pre-charge again, the Control Center's compressor switch must first be placed into the STOP/RESET position.

Harmonic Filter - High Baseplate Temperature

Message: **High Filter Baseplate Temperature Fault**

A thermistor sensor is located inside the IGBT Module on the harmonic filter power unit. If at anytime this thermistor detects a temperature higher than the shutdown threshold as determined by the harmonic filter logic board. Refer to the chart below for the shutdown threshold value. A manual reset is required by pressing the "Overtemp Reset" pushbutton located on the Filter Logic board.

Drive HP Rating	Threshold Shutdown Value
292, 351	175°F, 79°C
419,424,503,608	190°F, 88°C

Possible Problems:

- Improper coolant level for the drive.
- Shipping coolant not drained at start-up.
- Clogged chill plate.

Harmonic Filter - High Total Demand Distortion

Message: **Filtr High TDD Flt**

The control center determines this shutdown by using data supplied from the harmonic filter logic board. This shutdown indicates that the filter is not operating correctly or the input voltage to the OSCD/filter system is not sinusoidal. This shutdown will occur if the Total Demand Distortion (TDD) in any one phase exceeds 25% continuously for 45 seconds. TDD is an acronym for Total Demand Distortion, a term defined by the IEEE Std 519-1992 standard as "the total root - sum - square harmonic current distortion, in percent of the maximum demand load current (15 or 30 min demand)". In the filter option supplied by York, the displayed TDD is the total RMS value of the harmonic current supplied by the power mains to the OSCD system divided by the FLA of the OSCD, in percent. The harmonic filter option was designed to provide an input current TDD level of 8% or less for the OSCD system. A standard OSCD less the optional filter typically has an input current TDD level on the order of 28 - 30%. In order to initiate a chiller run again, the Control Center's compressor switch must first be placed into the STOP/RESET position.

Possible Problems:

- Failure of the harmonic filter logic board.
- Wiring error or failure between the harmonic filter logic board and the harmonic filter power unit.
- Verify that the 6 LED's are lit on the harmonic filter IGBT gate driver board. If one LED is not lit, then the IGBT gate driver board and IGBT module needs to be replaced.
- Ensure that all wiring to the filter logic board and the filter IGBT module are properly phased.

CYCLING SHUTDOWNS

General Information

The Shutdowns are organized in alphabetical order based on the OptiView Control Center Panel messages. The Microcomputer Control Panel messages are also included under these headings.

Whenever the OSCD or Harmonic Filter Logic Board generates a Cycling Shutdown a series of events will occur.

- If the chiller is not running at the time of the shutdown, the OSCD Logic Board will not turn on the IGBT gate drivers.
- The K1 relay on the OSCD logic board will de-energize causing an open circuit between J12-3 wire #53 and J12-4 wire #16. This action will indicate to the Control Center that the OSCD has shutdown. The K1 relay will remain de-energized until the cause of the shutdown has been corrected.
- If the chiller is running at the time of the shutdown, the Control Center will start a coastdown period (150 seconds for centrifugal chillers).
- The message “VSD Shutdown - Requesting Fault Data”...will be displayed when the Control Center is requesting the fault data from the OSCD.
- The OSCD or Harmonic Filter Logic Board will send a shutdown code via the serial communications link to the Adaptive Capacity Control Board and then to the Control Center. The Micro Board will interpret the shutdown code, and display a shutdown message on the display of the Control Center.

After the coastdown period has timed out, the chiller will automatically restart, if the shutdown is no longer active. Leave the Compressor Switch in the Run position. The chiller will start if no faults are active.

VSD - DC Bus Voltage Imbalance

Message: **Bus Voltage Imbalance Fault**

The DC link is filtered by many large, electrolytic capacitors, which are rated for 450 VDC. These capacitors are wired in series to achieve a 900 VDC capability for the DC link. It is important that the voltage is shared equally from the junction of the center, or series

capacitor connection, to the negative bus and to the positive bus. This center point should be approximately ½ of the total DC link voltage. If the voltage is greater than ± 88 VDC from the ½ of the total DC link voltage, then this shutdown will occur.

First verify the operation of the DC bus voltage isolation board, and all associated wiring to the OSCD logic board. Many times the actual bus voltage imbalance conditions are caused by a shorted capacitor, or a leaky or shorted IGBT transistor in the power unit. In order to check for these conditions, connect a 12 VDC source (such as a battery charger used to charge automobile batteries) and apply 12 VDC between the positive bus and negative bus plates on the power unit while measuring the voltage from center to plus, and center to minus. The bank, which is causing the imbalance, will be evident via unequal voltage readings.

Possible Problems:

- Bleeder resistors failure due to overheating. Ensure that thermal grease is applied when the resistors are replaced.
- OSCD's built after 5/05 no longer use thermal grease on the bleeder resistors. They use a thermal pad and a 2.4 k ohm resistor.
- Ensure that both of the bleeder resistors are of the same value. If one 2.0 k ohm resistor were to fail, then both resistors should be replaced with the 2.4 k ohm resistor and a thermal pad.
- Failure of the bus voltage isolation board. Use 2 DC volt meters to verify the voltage across the 2 halves of the DC bus. If the voltage is correct, then measure the DC bus voltage at the J3 connector of the OSCD logic board.
- A shorted or open capacitor in one half of the bank.

VSD - High DC Bus Voltage

Message: **Bus Over-Voltage Fault**

The DC bus voltage is continuously monitored by the OSCD logic board through the bus voltage isolation board. If the level exceeds 745 VDC (for 400 or 460 VAC line voltage) and 909 VDC (for 575 VAC line voltage), a shutdown is initiated. This shutdown will protect the capacitors from a voltage that exceeds this rating.

Possible Problems:

- Ensure that the line voltage is within the specification for your application. For example, the line voltage specification for a 460 VAC drive is 414 to 508 VAC or a 10% variation.
- Ensure that this shutdown is not a result of a storm.

VSD - High Internal Ambient Temperature

Message: **High Ambient Temperature FLT**

The ambient temperature of the OSCD is monitored by a temperature sensor mounted on the OSCD logic board. The high ambient trip threshold is set for 145°F (63°C) for all Hp's except the 424 Hp which has a trip threshold of 153°F (67°C). If this fault occurs, the fans and coolant pump will remain turn on until the internal ambient temperature has fallen to 137°F (58°C) for all Hp's except the 424 Hp will continue to run the fans and pumps until the internal ambient temperature has fallen to 145°F (63°C).

Possible Problems:

- Improper coolant level for the drive.
- Internal fan failure at the cooling coil.
- Entering condenser water temperature of greater than 114°F or 45°C.
- Dirty shell and tube heat exchanger. Regular maintenance of tube cleaning once a year is required.
- Low Condenser Flow - The OSCD system requires 8 feet of head on the condenser to maintain adequate GPM. If the head is less than 8 feet, it will be necessary to correct the flow problem, or add a booster pump as is sometimes applied on remote mounted retrofit OSCDs.
- Failure of the fan or pump relay.

VSD - High Phase A (or B, C) Instantaneous Current

Message: **Phase A (or B, C) Overcurrent Fault**

This shutdown is generated by the OSCD logic board. If any one phase of motor current as measured by the Output Current Transformers exceeds a threshold as determined by the OSCD logic board a shutdown will occur. Refer to the chart below for the shutdown threshold value.

Drive HP Rating	Threshold Shutdown Value
292, 351, 424	771 amps peak
419, 503, 608	1200 amps peak

If an Instantaneous Current Fault occurs, but the chiller restarts and runs without a problem, the cause may be attributed to a voltage sag on the utility power feeding the OSCD that is in excess of the specified dip voltage rating for this product. This is especially true if the chiller was running at, or near, full load. If there is a sudden dip in line voltage, the current to the motor will increase, since the motor wants to draw constant horsepower. The change in the output current due to an input power fluctuation is a very quick event on the order of several line cycles. The chiller vanes cannot close quickly enough to correct for this sudden increase in current, and the chiller will trip on this fault.

Possible Problems:

- Normal condition if a large power consuming device is started, such as another chiller, or large machinery. If this is the case then the chiller will auto restart.
- OSCD logic board failure. Rotate the J8, J9, and J10 connectors on the OSCD logic board. If the fault continues on the same output phase, then the OSCD logic board has failed. If the fault follows the output phase then continue. Be sure to return the connectors to their correct location after this test. If the connectors are not returned, then the KW reading will not be correct.
- Shorted OSCD power unit. Perform troubleshooting check for Failure of the OSCD Power Module.
- Power supply failure on the IGBT gate driver board will be indicated by one of the six LED not being lit.
- Shorted motor, Meg the motor phase to phase and phase to ground.
- The motor or compressor has a locked rotor. Ensure that the coupling between the motor and compressor is free to rotate.
- Power factor correction capacitors are applied on the same input line as the drive.
- Too much refrigerant in the chiller causing carry over.
- Refrigerant level sensor or system not working properly.

VSD - Initialization Failed

Message: **VSD Initialization Failed**

At power-up, the OSCD logic board will go through a process called initialization. At this time, memory locations are cleared, jumper positions are checked, and serial communications links are established between the OSCD logic board, ACC board, and the Control Center.

Possible Problems:

- The Control Center and the OSCD must be energized at the same time. The practice of pulling the fuse in the control center to make wiring changes will create a problem. Power-up must be done by closing the main disconnect on the OSCD cabinet with all fuses in place. Be sure you do not have an open fuse, causing loss of power to the OSCD logic board.
- The EPROMs must be correct for each board, and they must be correctly installed. There are a total of seven (7) EPROMs in each OSCD - Micropanel system. These EPROMs are created as a set, and cannot be intermixed between earlier and later styles of units. Also, the ACC EPROM must be in the ACC board, and the Micropanel EPROM in the Microboard, etc. All pins must be properly inserted into the EPROM sockets. Refer to the Software Reference List.
- Serial data communications must be established. See the write-ups for the messages, "Serial Receive Fault". If communication among the OSCD logic, the filter logic, the ACC board and the Microboard does not take place at initialization, the "VSD Initialization Failed" message will occur before any other message can be generated. You can check to see that serial communications has been established by selecting the Motor Screen and verifying the drive horsepower. A zero displayed value for this parameter (and all other OSCD parameters) indicates a serial communications link or EPROM problem.
- If the Harmonic Filter option is included, make sure the Harmonic Filter Logic board is not in continuous reset. This will be evidenced by the LEDs on the filter logic board alternately blinking. This situation is addressed elsewhere in this literature. To rule out the Harmonic Filter as the cause of initialization failure, you can disconnect the filter by switching the filter logic board's SW1 switch to the OFF position, and removing the 16 wire ribbon cable between the Harmonic Filter logic and OSCD logic boards.

- Many times when the OSCD logic board is replaced the small U40 chip is not transferred to the new board. Ensure that the U40 chip is properly installed.

VSD - Invalid Current Scale Selection

Message: **Invalid Current Scale Fault**

This shutdown is generated by the OSCD logic board. The J1 connector on the OSCD logic board contains jumpers along with wires from the output CTs. Since the part number of the logic board is the same on all horsepower sizes, the jumpers tell the logic board the size of the OSCD being employed in order to properly scale the output current. If the jumper configuration is found by the logic board to be invalid, the system will be shut down and the above message will be generated.

Possible Problems:

- The wire jumpers on the J1 connector or pins in the J1 connector of the OSCD logic board may not be properly installed, loose, or missing. Refer to the chart below for the proper jumper configuration.

Drive HP Rating	Wire Jumper Configuration
292, 351, 424	J1-9 to J1-10
419, 503, 608	J1-9 to J1-11

- If the wire jumper is not connected then the OSCD will tell the control center that an 1100 Hp drive is connected. The current displayed on the control center will be correct.

VSD - Logic Board Power Supply

Message: **Main Board Power Supply**

This shutdown is generated by the OSCD logic board, and it indicates that one of the low voltage power supplies for the OSCD logic board has dropped below their allowable operating limits. The power supplies for the logic boards are derived from the secondary of the 120 to 24 VAC transformer (Fig. 1) which in turn is derived from the 480 to 120 VAC control transformer (Fig. 1).

Possible Problems:

- This message normally appears when the power is removed and reapplied. This is not a failure, but the rest of the steps should be followed if this shutdown persists.
- The small control transformer that provides power to the OSCD is failing. Measure the output of the transformer with a DVM. The voltage should be between 24 – 32 VAC.

- The input voltage to the small control transformer is too low. Measure the input voltage of the transformer with a DVM. The voltage should be between 108 – 132 VAC.
- A power supply on the OSCD logic board may have failed. Measure the DC voltage test points on the OSCD logic board at TPC (+15V), TPD (+10V), TPE (+5V), TPF (+7.5V) and TPG (-15V) with respect to TPH (Ground). These power supplies have a tolerance of +/- 5%. If the measured voltage is not within the 5% tolerance then the power supply has failed, and the OSCD logic board should be replaced.

VSD - Logic Board Processor

Message: **PWM communications fault**

This shutdown is generated by the OSCD logic board. If a communications problem occurs between the two microprocessors on the OSCD logic board, then a shutdown will occur.

Possible Problems:

- If this shutdown should occur, replace the OSCD logic board.

VSD - Low Converter Heatsink Temperature

Message: **Low Conv Heatsink Temp.**

This shutdown is generated by the OSCD logic board. A thermistor sensor is located on the SCR/Diode block side of the copper chill plate on the OSCD Power Unit. If at anytime this thermistor detects a temperature of 37°F (3°C) or lower a shutdown will occur.

Possible Problems:

- In most cases, the problem will actually be an open thermistor or broken wiring to the thermistor. Remove the J2 connector from the OSCD logic board. With a DVM measure the resistance of the thermistor.

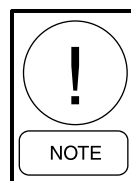

DO NOT insert the probes of the meter into the J2 connector where it makes a connection with the OSCD logic board. This will cause the sockets in the J2 connector to spread apart and cause an intermittent connection. Instead insert the probes into the back of the J2 connector.

Refer to Table 1 below for thermistor resistance verses temperature values.

- Also, make certain one side of the circuit is not shorted to the cabinet. Sometimes a thermistor wire can be pinched against the enclosure.

TABLE 1 – OSCD - THERMISTOR CHARACTERISTICS

TEMP°F NOMINAL	TEMP°C NOMINAL	R-THERMISTOR in ohms for Converter*	R-THERMISTOR in ohms for Baseplate
70	21	11900	4900
80	27	9300	4230
90	32	5600	3750
100	38	4600	3150
110	43	4660	2730
120	49	3760	2350
130	54	3050	1980
140	60	2490	1600
150	66	2040	1400
160	71	1690	1200
170	77	1400	950
180	82	1170	800
190	89	981	700
200	93	50	625

VSD - Low DC Bus Voltage

Message: **Low DC Bus Voltage Flt**

The OSCD logic board determines this shutdown with information from the bus isolator board. If the line voltage were to quickly drop the current seen by the motor could exceed its rating. The low bus voltage shutdown will prevent this from happening. The shutdown is generated when the DC link voltage drops below 500 VDC for 460 VAC input voltage, 414 VDC for 400 VAC input voltage, or 600 VDC for 575 VAC input voltage when the drive is running.

Possible Problems:

- A common cause for this shutdown is a severe sag in the AC line to the drive. Monitor the incoming three phase AC line for severe sags, and also monitor the DC link voltage with a digital meter.
- There could be a wiring problem between the DC link, bus isolator board, or the OSCD logic board. Refer to the wire diagram for the wire numbers. Measure the voltage at J3 on the OSCD logic board.
- The input voltage to the SCR trigger board must be properly phased with the SCR gate wiring. If the wiring is not correct, then misfiring of the SCR will result and may cause the circuit breaker to trip.
- Verify that the SCR/Diode assembly is not open.



Care must be taken when making this measurement. The value should be around 600 VDC when the drive is running.

VSD - Low Inverter Baseplate Temperature

Message: **Low Inverter Baseplate Temperature FLT.**

This shutdown is generated by the OSCD logic board. A thermistor sensor is located inside the IGBT Module, or Modules on the OSCD power unit. Temperature information is sent from the thermistor to the IGBT gate driver board, and then to the OSCD logic board. If at anytime this thermistor detects a temperature of 37°F (3°C) or lower a shutdown will occur.

Possible Problems:

- Refer to problems listed for the VSD – Low Converter Heatsink Temperature shutdown. The thermistor chart will not be the same for this thermistor.

VSD - Phase A (B, C) Gate Driver

Message: **Phase A (B,C) Gate Driver Flt**

A second level of overcurrent current protection exists on the OSCD gate driver board. The collector-to-emitter voltage of each IGBT is checked while the device is turned on. This is also called the collector-to-emitter saturation voltage. If the voltage across the IGBT is greater than a set threshold as defined on the gate driver board, the IGBT is turned off and a shutdown pulse is sent to the OSCD logic board shutting down the entire OSCD system. This fault can also be caused if an IGBT is not being turned on when it should.

Possible Problems:

- A power supply problem on the gate driver board. Verify that the 6 LED's on the gate driver board are lit on the 292/351/424 Hp OSCD. Verify that the 2 LED's on each gate driver board are lit on the 419/503/608 Hp OSCD. The gate drive board is located on top of the IGBT module. If any one of the LED's are not lit, then the bad gate driver board has failed and requires replacement of the OSCD power module.
- The power supplies for the gate driver boards are generated on the SCR trigger board. Verify the wiring between the SCR trigger board and the IGBT gate driver boards. To ensure that power supplies are good measure the voltage from TPF and TPG to ground. The voltage should be around 12.5 VDC. Also ensure that the voltage on J7 between pins 5 and 6, and pins 7 and 8 is 5 VDC.
- A failure may have occurred in the OSCD logic board. If the problem repeatedly occurs in one phase, swap all three gate driver board cables at the OSCD logic board J8, J9, and J10. Plug J8 into J9, J9 into J10, and J10 into J8. If the display now reports a trip in a different phase, the problem is not in the OSCD logic board. The cables must be returned to their proper location for proper KW reading to occur.

- The fault could also be caused by a problem in the drive line. Ensure that the compressor is free to rotate. Also ensure that the motor is not grounded phase to ground or phase to phase.
- Too much refrigerant in the chiller causing carry over.
- Refrigerant level sensor or system not working properly.

VSD - Precharge - DC Bus Voltage Imbalance

Message: **Precharge Bus V Imbalance**

The definition for this fault is identical to “VSD - DC Bus Voltage Imbalance”, except that the fault has occurred during the precharge period, which begins during pre-lube. Refer to “VSD - DC Bus Voltage Imbalance” shutdown for possible problems.

VSD - Precharge - Low DC Bus Voltage

Message: **Precharge Low Voltage Fault**

The OSCD logic board determines this shutdown with information from the bus isolator board. This fault has two different timing events. First, the DC Bus voltage must be equal to or greater than 50 VDC for 460 VAC input voltage, 41 VDC for 400 VAC input voltage, and 60 VDC for 575 VAC input voltage 4 seconds after pre-charge has begun. Second, the DC Bus voltage must be equal to or greater than 500 VDC for 460 VAC input voltage, 414 VDC for 400 VAC input voltage, and 600 VDC for 575 VAC input voltage 20 seconds after pre-charge has begun. This shutdown is important to determine if the converter or the cap. bank is shorted.

Possible Problems:

- Shorted cap. bank. Place a DC volt meter across the laminated bus structure. Measure the voltage. If voltage is present, then the caps. are not shorted. If voltage is not present, then take an ohm meter and verify if the cap. bank is shorted or not.
- The OSCD logic board is not getting bus voltage information. Place a DC volt meter at J3 on the OSCD logic board pins 1 and 3. Start the drive. If the voltage does not come up, then verify the wiring between the bus voltage isolation board, OSCD logic board, and the laminated bus structure.

- The converter is not being told to turn on. Verify that J4 on the SCR trigger board is properly installed. Verify that J6 on the OSCD logic board is properly installed. Measure the DC voltage at J4 on the SCR trigger board pin 3 to ground. The voltage should go to 0 VDC when the drive enters precharge. If this does not happen, then verify the wiring between the SCR trigger board and the OSCD logic board.
- The converter is not turning on. Verify the wiring between the SCR trigger board and the SCR gates. Also verify the wiring between L1-L3 on the SCR trigger board and L1-L3 to the input of the drive at the circuit breaker and up to the SCR anode connection.
- Measure the DC voltage at J1-J3 on the SCR trigger board. The voltage should be 1-3 VDC when the drive enters precharge. If the voltage is around 15 VDC, then the SCR trigger board has failed or the SCR gate is open. If the voltage is 0 VDC, the SCR trigger board had failed or the SCR gate is shorted.

VSD - Run Signal

Message: **Run Relay Fault**

Two run signals are generated by the Control Center, one via wire #24 and the second via the serial communications. Upon receipt of either of the two run signals by the OSCD logic board, a 5-second timer will begin on the OSCD logic board. If the missing run signal is not received within the 5-second window the OSCD logic board will shut down, and the Control Center will display the shutdown message.

Possible Problems:

- This shutdown could occur if there is a problem with the wiring between the Control Center and the OSCD logic board. Check the #24 to #25 horseshoe jumper in the Control Center, and all other wiring involved in energizing #24 in the OSCD.
- Verify that the serial communications wiring between the micro board, the ACC board, and OSCD logic board are connected properly.
- Verify the control center microboard communications is working properly. Refer to reference material for more information.

VSD - Serial Communications

Message: **Serial Receive Fault**

The OSCD logic board generates this message. When the communications between the micro board and the ACC board, or the ACC board and OSCD logic board is disrupted for a least 22 seconds.

Possible Problems:

- Ensure that the chiller system is properly grounded for electrical noise. The OSCD is the source of ground for the chiller. Ground is then conducted to the rest of the chiller by the mounting connections of the drive, compressor motor, and the Control Center. All connections are to be made with external tooth lock washers. These washers will cut through the paint on the chiller and provide a ground connection. The grounding system is critical for proper communications.
- Check the shielded cable between J11 on the OSCD logic board and J8 on the ACC board. Check for continuity and also check to see that none of the conductors are shorted together or shorted to ground. The terminal block in the lower left corner of the OSCD cabinet serves as a junction point for this cable, and it is possible for strands of wire to bridge across the terminals at this location.
- Verify that the shielded cable is properly grounded. Ensure that the chiller and the Control Center are properly ground through the OSCD. The shield should not be connected to chassis ground at the mounting plate for the conduit. The shield should only have one connection the Control Center enclosure. Remove the shield from the ground and verify that no other ground connections exist with an ohm meter. The shield should not go to ground through the ACC board. This has been a common problem on field retrofits. (If the optional harmonic filter is installed, then repeat this and the above step for the cable connected between the J9 connector on the ACC board and J8 connector on the filter logic board.)
- Ensure that the ACC board is properly grounded. In some cases, the ACC board is grounded through a very long wire. Changes were made to directly ground the ACC board to the Control Center enclosure. J6 pin 1 is the ground connection for the ACC board. This pin should be connected to the Control Center enclosure right next to the ACC board.

- Ensure that newer software is installed in the ACC board. Communications were improved with software version C.ACC.01.03a and later.
- Improper connection of the J9 connector on the ACC board. The J9 connector on the ACC board is for the communications from the harmonic filter logic board. If the harmonic filter is not installed, then the cable connected to J9 can be a source of electrical noise. The J9 connected should be removed from the ACC board if the optional harmonic filter is not installed.
- If the harmonic filter is installed, then the fault can be generated when the communications between the OSCD logic board and the harmonic filter logic board, or the harmonic filter logic board and the ACC board is disrupted. If possible disconnect the harmonic filter logic board to determine if it is at fault. If the communications work properly with the harmonic filter logic board disconnected, then verify the software version. If the software version is correct, then replace the board.
- If all of this has been done and communications can never be established, even at power-up, you may have a bad communications driver on either the OSCD logic or the ACC boards. Change out both the ACC and OSCD logic boards.

VSD - Single Phase Input Power

Message: **Single Phase Power Supply**

This shutdown is generated by the SCR Trigger board and relayed to the OSCD logic board to initiate a system shutdown. The single phase control uses circuitry to detect if any one phase has dropped below 230 VAC for a 460 VAC 60 Hz or 400 VAC 50 Hz line, or 300 VAC on a 575 VAC 60 Hz line. The trigger board will detect the loss of a phase within one half line cycle of the phase loss. An LED on the SCR Trigger board will indicate that the board is detecting the fault, and not a wiring problem between the SCR trigger board and the OSCD logic board.

Possible Problems:

- This message is typically displayed every time power to the OSCD is restored or if the input power dips to a very low level. This is not an indication of a problem with the OSCD.

- Verify the input fuses to the SCR trigger board are not open. The fuses that supply power to the SCR trigger board also supply power to the oil pump motor and the oil heater. A failed fuse may indicate a failure in one of these other components.
- Verify continuity between the J4 connector on the SCR trigger board and the J6 connector on the OSCD logic board. A failure in the wiring can cause this shutdown.

VSD - Stop Contacts Open

Message: **Inverter Initiated Stop Fault**

Whenever the OSCD initiates a fault, it first opens the K1 relay on the OSCD logic board. When the relay opens the voltage between wire #53 and #16 will be 115 VAC. It then sends a message through the serial port to the ACC board, detailing the cause of the fault. If wire #53 to #16 circuit ever opens without receiving an accompanying cause for the trip over the serial link (within 11 communication tries, approximately 22 seconds) this message will be displayed. This message will also be displayed if the verification jumper on J1 pins 7 & 8 are loose or not connected to the OSCD logic board. This fault maybe replaced with a Serial Communications fault if the serial link has failed.

Possible Problems:

- Ensure that all wiring from wire #1 to #53 horseshoe jumper in the Control Center and all other wiring involving #53 and #16 are properly connected.
- Verify that the J1 connector on the OSCD logic board is properly installed. Also ensure that the J1 pin 7 and 8 jumper is installed and the pins are properly seated.

Harmonic Filter - 110 % Input Current Overload

Message: **Filtr Overload Flt**

This shutdown is generated by the harmonic filter logic board. The three phases of filter current are measured by the output DCCTs, and information is sent to the harmonic filter logic board. If any one phase of filter current exceeds a threshold for 40 seconds a shutdown will occur. Refer to the following table for the shutdown threshold value.

Drive HP Rating	Threshold Shutdown Value
292/351/424	128 amps RMS
419/503/608	176 amps RMS

Possible Problems:

- Verify that the values of Total Harmonic Distortion (THD) are low and balanced. Turn off the OSCD and monitor the THD for each phase. The value should be around 5%. If the value of THD is much higher or if it is not balanced, then the harmonic content of the line is too high and the harmonic filter is responding to it.
- Ensure that the values of Total Demand Distortion (TDD) are balanced. If the currents are not balanced, then there may be a problem in the harmonic filter power unit or the harmonic filter logic board. Verify the wiring between the harmonic filter logic board and the harmonic filter power unit.

Harmonic Filter - DC Bus Voltage Imbalance

Message: **Filtr Bus V Imbalance Flt**

The DC bus voltage isolation board provides a high resistance between the harmonic filter DC link and the harmonic filter logic board. This resistance limits the current flowing between the bus capacitors and the Harmonic filter logic board. The harmonic filter logic board then determines if this fault has occurred.

The filter DC link is filtered by large, electrolytic capacitors, which are rated for 450 VDC. These capacitors are wired in series to achieve a 900 VDC capability for the DC link. The 424 and 608 Hp drives use higher voltage rated capacitors, but 2 in series are still required. It is important that the voltage be shared equally across each capacitor, or the capacitor rating may be exceeded and possibly fail. The DC isolation board is connected to the plus bus, minus bus, and where the 2 series capacitors are connected to each other. The harmonic filter logic board then measures the voltage between the plus bus and the series connection, and the minus bus and the series connection of the bus capacitors. If at anytime while the harmonic filter is running these 2 measurements become unequal by 50 VDC (for 460 and 400 VAC input voltage) 65 VDC (for 575 VAC input voltage), then a shutdown will occur.

Possible Problems:

- Bleeder resistors failure due to overheating. Ensure that thermal grease is properly applied when the resistors are replaced. With power removed from the drive and the DC link voltage discharged below 10 VDC, disconnect the harmonic filter bleeder resistors. Measure the ohm value of the bleeder resistors. The ohm value should be 3000 ohms within 5%. Drives

built after 5/05 no longer use thermal grease, but use a thermal pad. Ensure that the resistors are properly tightened to the assembly. No torque specification is required.

- Verify all wiring between the DC link and the harmonic filter logic board. Also check for loose connections.
- Failure of the bus voltage isolation board. With power removed from the drive and the DC link voltage discharged below 10 VDC, disconnected the bus voltage isolation board from the circuit. Using an ohm meter measure from J1-1 to J2-1. The ohm value should be 150 K ohms. Repeat this test for the remaining 2 connections. If any one of the reading is not 150 K ohms to within 1%, then the board needs to be replaced.
- Shorted capacitor in one half of the DC link. Place one DC volt meter from the plus bus to the series connection of the capacitors, the other from the series connection of the capacitors to the minus bus. Start the drive. When the drive starts to rotate the motor the harmonic filter will start to precharge. The precharge of the harmonic filter takes 5 seconds. During this time, the voltage should remain equal to within the specification above. If a capacitor is shorted, then one of the volt meters will have a low voltage reading. This is the side of the DC link that has failed. Remove power from the drive, and ensure that the DC link voltage is below 10 VDC. Remove the laminated bus structure from the harmonic filter power unit. With an ohm meter measure the resistance of the DC link capacitors. A low reading would indicate a failed capacitor. Replace the cap. When replacing the capacitor ensure that the top of the capacitor is at the same height as the other capacitors in the DC link.
- An open capacitor can cause this problem as well. Using an analog meter on Rx10. Connect the meter to one side of the capacitor bank. The meter should first read a short and then the resistance should increase. The same test with the same results should be repeated for both side of the capacitor bank in both polarities. If the needle of the meter shows a resistance without first showing a short, then repeat the test. If the reading does not change then the capacitor is open and should be replaced.

- Failure of the harmonic filter logic board. Measure the voltage of the DC link at the harmonic filter logic board. This measurement is taken at J5 pins 5 and 6, J5 pins 6 and 7. During the precharge of the harmonic filter these 2 measurements should remain equal to within the specification above. If the measurements are correct, then the harmonic filter logic board has failed.

Harmonic Filter - DC Current Transformer 1(or 2)

Message: **Filter DCCT 1 (or 2) Error**

During initialization, with no current flowing through the Direct Current Current Transducers (DCCT's), the DCCT's output voltages are measured and compared with a preset limit in the harmonic filter logic board. If the measured values exceed the preset limits, the DCCT's are presumed to be bad and this shutdown will be generated.

Possible Problems:

- Verify the wiring between the DCCT's and the harmonic filter logic board.
- Power supply failure to the DCCT. Check for the presence of the +15 VDC power supplies by measuring the voltages at filter logic board J3 pins 6 and 10 with respect to signal ground (J3 pin 2). Check for the presence of the -15 VDC power supplies by measuring the voltages at filter logic board J3 pins 7 and 11 with respect to signal ground (J3 pin 2). If the power supply is not correct, then replace the harmonic filter logic board.
- The output voltage from the DCCT is not correct. While the OSCD is powered but not running, measure the DC voltage from J3 pin 5 and J3 pin 12 with respect to signal ground (J3 pin 2) on the harmonic filter logic board. Neither voltage should be greater than +/- 0.147 VDC. If the above step is correct, and this step fails, then replace the failed DCCT.

Harmonic Filter - High DC Bus Voltage

Message: **Fltr Bus Over-Voltage Flt**

The harmonic filter logic board continuously monitors the harmonic filter DC link voltage if the level of the DC link voltage exceeds a range of 822 to 900 VDC (for 460 and 400 VAC input voltage) 999 to 1099 VDC (for 575 VAC input voltage), this shutdown is initiated.

Keep in mind that the harmonic filter has its own DC bus as part of the harmonic filter power unit. The harmonic filter DC Link is not connected in any way with the drive's DC Link.

Possible Problems:

- Verify that the line voltage is not greater than the specified input voltage range for this model of drive.
- Voltage surge on the input line voltage. Ensure that power quality has not changed during the shutdown. This could include storms, line switching, or rapid changes in line loading.

Harmonic Filter - High Phase A (B, C) Current

Message: **Filtr Phase A (B,C) Overcurrent**

The output current of the harmonic filter is read by the Direct Current-Current Transducer (DCCT). This current information is sent to the harmonic filter logic board where it is compared against a threshold. If the output current of the harmonic filter power unit is greater than the threshold, then the harmonic filter will turn off for 5-6 line cycles. After that time the filter operation will resume. If the harmonic filter operation is stopped 3 times within a period of 60 line cycles, then the filter and OSCD power units are shut down and this message is generated.

Drive HP Rating	Threshold Shutdown Value
292/351/424	378 ±59 amps Pk
419/503/608	523 ±84 Amps Pk

Possible Problems:

- Line voltage transients. If the OSCD shutdown and auto-restarts without any additional problems, then the problem is likely due to a sag or surge in the line voltage.
- Filter power unit failure. In some cases, the IGBT in the harmonic filter power unit has failed. Refer to troubleshooting procedure for failure of the Harmonic Filter Module to determine this failure.

Harmonic Filter - Logic Board Or Communications

Message: **IEEE-519 Filter Fault**

This shutdown states that the hardware on the harmonic filter logic board is indicating a fault, but the software on the harmonic filter logic board does not state why. The filter logic board signals a fault condition by opening

a transistor. The OSCD logic board detects the open transistor at the J7 connector pin 9. In turn, the OSCD logic board then opens its fault relay to indicate a fault to the Control Center. When fault data is requested of the harmonic filter logic board it does not respond with fault information.

Possible Problems:

- Verify the 16-pin ribbon cable for continuity between the OSCD logic and Harmonic Filter logic boards. Focus on this test around pin 9 of the cable.
- Ensure that the communication system is working between the Harmonic Filter logic board, the Adaptive Capacity Control board, and the OSCD logic board.

Harmonic Filter - Logic Board Power Supply

Message: **Filtr Power Supply Flt**

This shutdown indicates that one of the low voltage power supplies on the harmonic filter logic board have dropped below their permissible operating voltage range. The filter logic board receives its power from the OSCD logic board via the ribbon cable, which connects the two. The power supplies for the OSCD logic boards are in turn derived from the secondary of the 120 to 24 VAC transformer (Fig. 2), which in turn is derived from the AC line input to 120 VAC control transformer (Fig. 1).

Possible Problems:

- Verify that CR10 LED is lit on the harmonic filter logic board. This LED indicates that the power supplies on the board are ok. If the CR10 LED is lit, then likely the harmonic filter logic board has failed, and it needs to be replaced.
- If CR10 LED is not lit, then verify the ribbon cable for continuity between the OSCD logic and Harmonic Filter logic boards.
- Verify the power supply voltages on the harmonic filter board. With a voltage meter verify the following voltages.

J7 pin 3-7 is +15 VDC

J7 pin 4-7 is +5 VDAC

J7 pin 5-7 is -5 VDC

J7 pin 6-7 is -15 VDC

Harmonic Filter - Low DC Bus Voltage

Message: **Filtr Low Bus Voltage Flt**

The harmonic filter dynamically generates its own filter DC link voltage by the interaction of the harmonic filter choke and switching its IGBT's. This DC level is actually higher than the level obtained by simply rectifying the input line voltage. **Note: The DC link voltage is always higher on the harmonic filter power unit than on the OSCD VSD power unit.** Thus the harmonic filter actually performs a voltage "boost" function. This is necessary in order to permit current to flow into the AC line from the harmonic filter when the AC line is at its peak level. This particular shutdown and its accompanying message are generated when the harmonic filter's DC link voltage drops to a level less than 80 VDC (for 460 and 400 VAC input voltage) 100 VDC (for 575 VAC input voltage), below the harmonic filter DC link voltage setpoint. The harmonic filter DC link voltage setpoint is determined by the harmonic filter logic board by measuring the three phase input line-to-line voltage. The harmonic filter logic board measures the input line voltage through the AC line isolator board. This setpoint is set to the peak of the sensed input line to line voltage plus 59 volts (for 460 and 400 VAC input voltage) 118 VDC (for the 608 Hp drive) and 88 volts (for the 424 Hp drive), but not to exceed 760 volts (for 460 and 400 VAC input voltage) 993 VDC (for 575 VAC input voltage). The setpoint will vary with changes in the input line to line voltage.

Possible Problems:

- If this shutdown occurs occasionally, the likely cause is a severe sag in the input line voltage. A power monitor should be installed to determine if a power problem exists.
- Verify the operation of the AC line voltage isolator board. Measure the output of the line voltage isolation board at connector J5, pins 1, 2, and 3 on the harmonic filter logic board. With 480 VAC present on the input to the line voltage isolation board, approximately 5.2 VAC should be present from pins 1 to 2, pins 2 to 3, and pins 3 to 1. The voltages should be balanced as opposed to the voltage being exactly 5.2 VAC.

Harmonic Filter - Phase Locked Loop

Message: **Filtr Phase Lock Loop Flt**

This shutdown indicates that a circuit called a "phase locked loop" on the harmonic filter logic board has lost synchronization with the incoming power line for a period of time.

Possible Problems:

- This is normally an indication that one of the harmonic filter's input power fuse is open. Check the operation of the harmonic filter power fuses 8FU, 9FU and 10FU.
- If the fuses are OK, then measure the output of the line voltage isolation board at connector J5, pins 1, 2, and 3 on the harmonic filter logic board. With 480 VAC present on the input to the line voltage isolation board, approximately 5.2 VAC should be present from pins 1 to 2, pins 2 to 3, and pins 3 to 1. The voltages should be balanced as opposed to the voltage being exactly 5.2 VAC.

Harmonic Filter - Precharge - Low DC Bus Voltage

Message: **Filtr Pcharge Low Bus V Flt**

This shutdown requires that two minimum voltage thresholds must be exceeded in order to complete precharge. The first minimum voltage value occurs within 1/10 of a second. The second minimum voltage value occurs near the end of the precharge at 5 seconds after the filter precharge relay is energized. View chart below for specific values. The unit is shut down, and this message is generated if these conditions are not met.

Nominal Input Voltage Value	First Minimum Voltage Value	Second Minimum Voltage Value
400 VAC	41 VDC	425 VDC
460 VAC	50 VDC	525 VDC
575 VAC	60 VDC	630 VDC

Possible Problems:

- Verify that the harmonic filter pre-charge relay is energized during pre-charge. If it is not, then verify wiring between the pre-charge relay and J4 pins 1 and 2 on the harmonic filter logic board.
- Verify that the harmonic filter pre-charge resistors are the correct ohm value, and are not damaged.

Drive HP Rating	Pre-Charge Resistor Value
351/292	10 ohms
503/419	16 ohms

- Measure the harmonic filter bus voltage during pre-charge to ensure that the bus is charging to the correct value or not. If bus is charging properly, then measure the bus voltage at J5 pin 5 to 7. The value at J5 should be nearly the

same as the bus voltage measured on the bus. If the measurement is not the same, then measure the 3 resistors on the DC bus isolator board. Disconnect the DC bus isolator board and measure resistance at the terminals of the board. The measurement should be 150K ohms +/- 1%. If this measurement is not correct, then replace the DC bus isolator board. If the measurement is correct, then replace the harmonic filter logic board.

Harmonic Filter - Run Signal

Message: **Filtr Run Relay Flt**

When a digital run command is received at the harmonic filter logic board from the OSCD logic board via the 16 position ribbon cable, a 1/10 second timer is begun. A redundant run command must also occur on the serial data link from the OSCD logic board via the ribbon cable before the timer expires or the OSCD will be shut down and this message will be displayed.

Possible Problems:

- Verify the 16-pin ribbon cable for continuity between the OSCD logic and Harmonic Filter logic boards. Focus on this test around pin 12 of the cable.
- If the problem persists, replace the OSCD logic board and if the problem remains, the filter logic board.

WARNING MESSAGES

General Information

A WARNING message will indicate that the operation of the OptiSpeed Compressor Drive or the Harmonic Filter is affected in some manner, but the OptiSpeed Compressor Drive is still functioning.

Warning – Vanes Uncalibrated – Fixed Speed

Message: **Vanes Uncalibrated – Fixed Speed**

This message is displayed when the Pre-Rotation Vanes are not calibrated or have failed to calibrate, and the OptiSpeed Compressor Drive is enabled. Under this condition the OSCD will run at a constant maximum frequency. This message will no longer appear after a successful calibration.

Possible Problems:

- Ensure that the vane pot. is adjusted for zero vane opening. With the vanes fully closed, the DC voltage measured at J4 on the Adaptive Capacity Control board pin 1 to 2 should be 0.3 to 0.7 VDC. If this value is not correct, then adjust the vane pot. coupling.
- Verify the communications between the Adaptive Capacity Control, OptiSpeed Compressor logic, chiller Control Logic, and the Harmonic Filter logic boards.
- Ensure that the harmonic filter logic board is not in a reset condition. This is where the fault LED is flashing on the harmonic filter logic board.

Verify that the correct EPROM versions are installed, and that the EPROM's are installed in the proper orientation. Ensure that the (2) 8 pin chips are properly installed as well. Many times the 8 pin chips are missed during a board replacement.

- Verify that the correct line number harmonic filter logic board is installed. Different line number boards are used for different horsepower OSCD.

Warning - Harmonic Filter - Operation Inhibited

Message: **Filter - Operation Inhibited**

This message is displayed when the function of the Harmonic Filter is inhibited at the Control Center. This message is no longer displayed when the function of the Harmonic Filter is enabled at the Control Center. The function of the harmonic filter can only be inhibited or turned on when the chiller is stopped.

Warning - Harmonic Filter - Data Loss

Message: **Filter Data Loss**

This message is displayed when the communications link between the OSCD logic, and the harmonic filter logic, or the ACC boards are interrupted for at least a period of 20 seconds. This message can also occur as a background message when the chiller is running. When this message is displayed all filter related values are

replaced with X's. If communications is re-established, the message will disappear, and normal values will again be displayed.

Possible Problems:

- Verify the 16-pin ribbon cable for continuity between the OSCD logic and Harmonic Filter logic boards. Focus this test around pin 9 of the cable.

- The integrity of the shielded communications cable between the harmonic filter logic board and the ACC board should also be checked.
- Ensure that the OSCD and the Control Center are properly grounded.
- Possibly a board failure has occurred. Replace the harmonic filter logic board.

START-UP PREPARATIONS

Circuit Breaker Setup

The circuit breaker used on the OSCD has many settings for overload, short circuit, and ground fault protection. Generally, these setting are adjusted by the manufacture, but these setting should be verified before starting the chiller. The breaker settings on the 292/351 Hp OSCD are a little different then the 419/503 Hp OSCD. The

292/351 Hp OSCD have settings for Instantaneous Short Circuit Trip Time and Ground Fault Trip Time have an ON and OFF adjustment. Verify that these two adjustments are set to the ON position. With the introduction of the 424 and 608 Hp drives new circuit breakers are being used.

Settings for the 292/351 Hp OSCD Circuit Breaker Part Number 224-30987-000 (Used Before 6/06)

<u>Name of Adjustment</u>	<u>Abbreviation of Adjustment</u>	<u>Setting Value</u>
• Long Time Overload Protection Coarse Multiplier	“IO”	“1”
• Long Time Overload Protection Fine Multiplier	“IR”	“1”
• Short Time Overload Protection Multiplier	“ISD”	“1.5”
• Instantaneous Short Circuit Protection Multiplier	“II”	“2”
• Ground Fault Protection Multiplier	“IG”	“0.2”
• Short Time Overload Trip Time	“TR”	“0.5”
• Instantaneous Short Circuit Trip Time	“TSD”	“0.1” ON
• Ground Fault Trip Time	“TG”	“0.1” ON

Settings for the 292/351/424 Hp OSCD Circuit Breaker Part Number 224-35428-000 (Used After 6/06)

<u>Name of Adjustment</u>	<u>Abbreviation of Adjustment</u>	<u>Setting Value</u>
• Long Time Pickup	“IR”	“E”
• Short Time Overload Protection Multiplier	“ISD”	“1.5”
• Instantaneous Short Circuit Protection Multiplier	“II”	“2”
• Ground Fault Protection Multiplier	“IG”	“0.2”
• Short Time Overload Trip Time	“TR”	“0.5”
• Instantaneous Short Circuit Trip Time	“TSD”	“0.1” ON
• Ground Fault Trip Time	“TG”	“0.1” ON

Settings for the 419/503/608 Hp OSCD Circuit Breaker

<u>Name of Adjustment</u>	<u>Setting Value</u>
• Short Delay Pickup	“2”
• Short Delay Time	“inst”
• Ground Fault Pickup	“1”
• Ground Fault Time	“inst”

OptiView Control Center

Make certain the correct EPROMs are all installed in the proper locations by referring to the EPROM Reference List in this form. The list at the end of this form contains the earliest versions in which the product is supported. Be sure the dimple in the end of the chip is oriented in the correct direction. Ensure that jumper JP37 is cut on the OptiView panel micro board 031-01730-XXX.

Verify the circuit breaker settings (refer to the first section in the start-up preparations). Apply power to the OSCD, and check the System Status Line on the Control Center. After a few seconds you should get the message, "System Ready to Start". If you do not, turn off power, wait five minutes for the voltage to discharge, verify voltage is no longer present, and then double check all wiring and connections.

At this point, start-up is as simple as one, two, three...

1. If initial power-up is successful, set the Full Load Amps (FLA) on the OSCD by selecting the VSD Details Screen. On this screen is displayed the "Full Load Amps (some value)". Adjust this value to the FLA stamped on the compressor motor name plate by turning the small multi-turn trimpot located in the left-center area of the OSCD logic board inside the OSCD enclosure. Clockwise rotation of the trimpot will increase the value of FLA. You will need to alternate between making an adjustment, and checking the value on the Control Center, until the displayed value is correct within one amp.
2. Next, drain the coolant from the OSCD. The OSCD is now shipped with a 50/50 mix of Propylene Glycol and York Corrosion Inhibitor. This type of coolant is being used to protect the cooling loop from damage due to freezing conditions during the shipping process. This coolant mixture does not have the thermodynamic properties required by the OSCD during a running condition. Thus, this 50/50 mixture must be drained and replaced with YORK Corrosion Inhibitor as currently used in the OSCD. **Propylene Glycol is the same material used to winterize recreational vehicles. Although, it is non-toxic, follow any applicable local codes when discarding the solution.**
3. Next, fill the coolant loop using York's Corrosion Inhibitor, part number 013-02987-000. Pour the solution into the top of the header pipe until the level is within a ½ inch of the top. Then run the pump by unplugging connector P2 on the OSCD logic board. The level in the fill-pipe will drop quickly.

Add more coolant so the level is maintained at ½ inch from the top of the pipe. Continue to run the pump for 15 minutes, adding more coolant as needed, then reinstall P2, make certain the level is ½ inch from the top, and install the pipe plug in the header pipe using teflon tape to assure coolant does not evaporate through the pipe threads. Do not wrap the threads with more than 2 wraps of Teflon tape. Too much tape can cause the fill pipe to crack. **Note the pipe plug has straight threads, and could fall into the reservoir.**

4. The BRAM on the ACC board should be cleared to ensure that the surge map is clean, and no data is stored that may keep the OSCD from slowing down. This procedure should not be performed on a regular basis, and will cause extra surging of the compressor.
 - Enter an Access Code of 1380
 - Select the Motor Screen
 - Select the ACC Details Screen
 - Press the Surge Map Clear key
 - A window will appear prompting for a code. Enter the value of 0368, and press the check key.
 - Open the OptiView Control Center door and press the small SW1 button on the ACC board. This must be performed within 20 seconds of pressing the check key. Also the small button must be pressed for 1-3 seconds.
 - A message will appear that the surge map has been cleared. To verify that the surge map is cleared check that the vane position no longer reads 0 and now displays X.
5. The vanes must now be calibrated. The vane pot itself was previously installed, and should have been set so that neither end of travel runs up against either end-stop of the pot. The closed end of the pot should be set for a feedback voltage somewhere between 0.3 and 0.7 VDC, as measured from the wiper (white wire) to common (black wire). The full-open feedback voltage must be greater than the closed value by 0.10 VDC. For example, you might get a range of 0.54 VDC closed, to 1.12 VDC at full open. This range of voltage will be scaled by the Adaptive Capacity Control Board (ACC) to a range of 0% to 100% open. The ACC will store the voltage that corresponds with the percentage of vanes in it's BRAM chip.

This scaling is accomplished by an automatic calibration routine in the OptiView Control Center. To perform the auto-calibration perform the following:

- Enter an Access Code of 1380
- Select the Compressor Screen
- Select the Pre Rotation Vane Calibrate Screen
- Press the Start Calibration key
- The Calibration in Progress and Pre Rotation Vane Opening LEDs' will light.
- The vanes will run to the full open position and stop.
- After a short period of time, the Pre Rotation Vane Closing LED will light.
- The vanes will run to the full closed position and stop.
- A message will appear on the screen, "PRV Calibration was Successful"
- If "PRV Calibration was Successful" is not displayed, then verify the operation of the vane arm, vane pot, the cable between the vane pot and the ACC board, and that the shield of the vane pot. is connected to the OptiView Control Panel enclosure.

If any difficulty is encountered with these procedures, refer to the other sections of this publication for solutions.

Micro Computer Control Center

Make certain the correct EPROMs are all installed in the proper locations by referring to the EPROM Reference List in this Form. Be sure the dimple at the end of the chip is oriented in the correct direction.

Verify the circuit breaker settings (refer to the first section in the start-up preparations). Apply power to the OSCD, and check the front panel display. After a few seconds you should get the message, "System Ready to Start". If you do not, turn off power, wait five minutes for the voltage to discharge, verify voltage is no longer present, and then double check all wiring and connections.

At this point, start-up is as simple as one, two, three...

1. If initial power-up is successful, set the Full Load Amps (FLA) on the OSCD by pressing the "Options" key. You will see a display of "VSD 100% Job FLA = (some value) Amps". Adjust this value to the correct FLA as stamped on the motor name plate by turning the small multi-turn trimpot located

in the left-center area of the OSCD logic board inside the OSCD enclosure. Clockwise rotation of the trimpot will increase the value of FLA. You will need to alternate between making an adjustment, and checking the value on the display, until the displayed value is correct within one amp.

2. Next drain the coolant from the OSCD. The OSCD is now shipped with a 50/50 mix of Propylene Glycol and York Corrosion Inhibitor. This type of coolant is being used to protect the cooling loop from damage due to freezing conditions during the shipping process. This coolant mixture does not have the thermodynamic properties required by the OSCD during a running condition. Thus, this 50/50 mixture must be drained and replaced with YORK coolant as currently used in the OSCD. Propylene Glycol is the same material used to winterize recreational vehicles. Although it is non-toxic we suggest permission should be obtained before discarding it into a sewer.
3. Next, fill the coolant loop using York's pre-mixed Corrosion Inhibitor solution, part number 013-02987-000. Pour the solution into the top of the header pipe until the level is within a ½ inch of the top. Then run the pump by unplugging connector P2 on the OSCD logic board. The level in the fill-pipe will drop quickly. Add more coolant so the level is maintained at ½ inch from the top of the pipe. Continue to run the pump for 15 minutes, adding more coolant as needed, then reinstall P2, make certain the level is ½ inch from the top, and install the pipe plug in the header pipe using teflon tape to assure coolant does not evaporate through the pipe threads. Do not wrap the threads with more than 2 wraps of Teflon tape. Too much tape can cause the fill pipe to crack.
4. The BRAM on the ACC board should be cleared to ensure that the surge map is clean, and no data is stored that may cause the OSCD from slowing down. **This procedure should not be performed on a regular basis, and will cause extra surging of the compressor.**
 - Enter an Access Code of 1397
 - Enter Program Mode
 - Press the CHILLED LIQUID TEMPS key under the DISPLAY section. The following message shall appear:

Message: **BRAM OPTION :**

- Enter the number 368 (the value will be replaced with stars on the display) then press the ENTER key, the following message shall appear.

Message: **BRAM OPTION IN PROGRESS . . .**

- While the above message is present press and hold SW1 push button on the ACC board for 3 seconds. If the button is not pressed within 20 seconds the option will be aborted. The switch is located at the left center of the board. The following message shall appear.

Message: **BRAM OPTION COMPLETE**

- To verify that the surge map is cleared check that the vane position no longer reads 0 and now displays X.

5. The vanes must now be calibrated. The pot itself was previously installed, and should have been set so that neither end of travel runs up against either end-stop of the pot. The closed end of the pot should be set for a feedback voltage somewhere between 0.3 and 0.7 VDC, as measured from the wiper (white wire) to common (black wire). The full-open feedback voltage must be greater than the closed value by 0.1 VDC. For example, you might get a range of 0.54 VDC closed, to 1.12 VDC at full open. This range of voltage will be scaled by the Adaptive Capacity Control Board (ACC) to a range of 0% to 100%. The ACC will store the voltage that corresponds with the percentage of vanes in it's BRAM chip.

This scaling is accomplished by an automatic calibration routine in the Micro Computer Control Center. To perform the auto-calibration perform the following:

- Enter an Access Code of 1380
- Change the operating mode of the Micro Computer Control Center to the VSD Service Mode (not Service mode)
- Check to ensure that the Micro Computer Control Center is in the Program Mode
- Press the Open key.
- A message will appear on the display, "Calibration in Progress - Vanes Opening"
- The vanes will run to the full open position and stop.
- After a few seconds, a message will appear on the display, "Calibration in Progress - Vanes Closing"
- The vanes will run to the full closed position and stop.
- A message will appear on the display, "Calibration Successful"
- If so, press the Enter key to accept this calibration. Calibration is not accepted unless the Enter key is depressed.

If "Calibration Successful" is not achieved, then press the cancel key to abort the procedure. Verify the operation of the vane arm, vane pot. the cable between the vane pot and the ACC board, and that the shield of the vane pot. is connected to the OptiView Control Panel enclosure.

If any difficulty is encountered with these procedures, refer to the other sections of this publication for solutions.

VSD FREQUENTLY ASKED QUESTIONS

Why doesn't the measured input amps of the OSCD agree with the rated FLA?

The input current to the OSCD may be considerably lower, compared to the output current. This is due to the power factor at the input to the OSCD being greater than .95, and nearly unity when the Harmonic Filter option is included. Chiller FLA must be measured at the motor terminals, where the power factor is the normal motor power factor. Use a true RMS reading meter to make these measurements.

How can I manually control the speed of the drive?

For the OptiView Control Panel, first enter the Service Access Level. Select the VSD Tuning Screen from the Compressor Screen. From this screen the speed of the drive can be set to a specific frequency, raise or lowered by a specific amount of frequency, or set for fixed speed (60Hz). Press the AUTO key to return speed control to the ACC board.

For the Micro Computer Control Center, first enter the VSD Service mode. Once in the VSD Service mode, make certain you are NOT in program mode by pressing the program button and watching the display. With the panel NOT in program, you can adjust the frequency setpoint using the increment and decrement keys which are combined with the vanes open and closed buttons. You can also select fixed 60HZ by pressing the 60HZ key. The OSCD will begin to change speed, moving toward the manual setpoint you entered. It may take some time to attain the programmed frequency. To exit the manual OSCD speed mode, press the Auto key. Be sure the unit is in Auto speed mode before exiting the VSD service mode, otherwise the unit will stay in the manual speed mode after exiting the VSD service mode.

How can the Pre Rotation Vanes be manually controlled when an OptiSpeed Compressor Drive is installed?

Regardless of which control center is used, the method of manual vane control remains the same as with a fixed speed chiller. Refer to the appropriate chiller Service Manual for these controls.

On a retrofit OptiSpeed Compressor Drive, what is the DV/DT Network for?

The combination of long runs of wire between the OSCD and the compressor motor, with the fast rise time of the output voltage of the OSCD can cause excessively high voltage potential at the motor terminals. Without the DV/DT Network, the insulation in the compressor motor may be overly stressed. The DV/DT Network reduces the high voltage potential to below the motor's voltage specification. The design of the DV/DT network currently in production has a requirement for installation on top of the motor terminal box. DO NOT add any additional wire between the motor terminal connections and the DV/DT Network. The additional wire will reduce the DV/DT Network's effectiveness, and potentially shorten the life of the motor.

On all OSCD's, a similar circuit is located on the back wall of the OSCD enclosure near the motor connections. Since this filter is already present inside the cabinet on all OSCD, some installers have questioned whether the internal circuit must be disabled when using the terminal box mounted accessory. The answer is no - you do not need to disconnect the DV/DT network inside the OSCD cabinet.

Is a Condenser Water Strainer used with the shell and tube heat exchanger?

Since the shell and tube heat exchanger can be cleaned with a rifle brush, no extra precautions are needed to keep the heat exchanger clean. No strainer is provided with this OSCD. The intent is to have the heat exchanger cleaned annually. Gaskets are available (refer to the service parts list).

What is the timing of the Anti-Recycle when an OSCD is applied?

The anti-recycle time is much quicker with an OSCD than with a starter. The reason is the elimination of inrush current on start-up. The OptiSpeed compressor drive slowly accelerates the compressor motor so that the motor does not consume more than 100% of the motor's nameplate full load amps. The anti-recycle time is five (5) starts in succession, followed by a ten minute wait. After ten minutes, you get five more successive starts. This is permitted on OSCD units only, due to the low current draw and reduced motor heating during startup.

Why does the condenser pressure transducer on a YT chiller need to be changed when an OSCD is applied?

For the OptiSpeed compressor drive to perform well it requires cooler condenser water. The cooler condenser water lowers the condenser pressure below the standard condenser pressure transducer's range. Thus, a new pressure transducer is required with a wider range of pressure. The new pressure transducer part number is 025-29148-009. Its range is 4 to 34 PSIA, with a proportional output of 0.5 to 4.5 VDC. The OSCD software for YT chillers require the use of this transducer.

What is the proper wire sizing when using an OptiSpeed Compressor Drive?

The input power wires to the OSCD are sized at 1.25 times the full-load amps of the compressor motor, plus oil pump amps and control transformer amps. Note this differs from the 1.38 multiplier used on earlier drives. OptiSpeed compressor drive to Compressor Motor wires need only be 1.25 times the compressor motor FLA, since the oil pump and control power are not part of the equation at this point.

Does the surge counter reflect the number of points in the surge map?

No, the surge counter increments each time the ACC detects a chiller surge, not each time a surge is added to the map. It is not uncommon to receive a chiller with some number of surges recorded in memory. The only way to zero this value is to zero the BRAM memory which stores the compressor surge map and other non-volatile data. Zeroing of the BRAM generally is not done unless some condition has caused false data to be stored - see section titled "Zeroing BRAM" below. Also, be aware it is not uncommon to find very high numbers of surges. We had one chiller which surged for two weeks, running 60 HZ, along with a fixed-speed chiller which was also surging due to tower problems. After two weeks, the customer decided it was time to fix the tower! In this case we logged over 18,000 surges.

Under what conditions should I zero the BRAM on the ACC board?

An internal lithium battery maintains the BRAM memory even if the power is removed. This chip is located on the ACC board. It stores the compressor surge map information, and other data such as the vane pot calibration. There are only 3 reasons where this memory

should be cleared - when the chiller has been running and storing invalid surge information due to a mis-calibrated vane pot, when the chiller has been running and storing invalid data due to a faulty condenser or evaporator transducer, and when the chiller is first started with an OSCD. Vane position and refrigerant pressures are two of the three pieces of information stored in the surge map, and if these values are false, the map created with false information will be a false map.

Any other conditions which may be abnormal will only cause the chiller to run at an abnormal part of the map, but will still be valid data for the conditions. For example, if the cooling tower should by-pass water, causing a false high-head, the ACC will figure out the best mode of operation for these conditions, even though they are abnormal. When the problem with the tower is fixed, the ACC will determine a new optimum operation on a different part of the map. Neither set of stored values is incorrect. If the same tower problem ever develops again, the chiller will already know what to do. If you believe you need to zero the BRAM, call YORK factory service for assistance.

Should I require the customer to install isolation between the Power Conduits and the OptiSpeed Compressor Drive?

We no longer require a section of non-metallic conduit at the entrance and exit to/from the OSCD as we did on previous products. If any customer or installer wishes to continue to follow this practice, we have no objections.

How does the MicroComputer Control Center provide power to the ACC board?

The ACC board is power by +30 VDC unregulated from the control center's power supply board. There are two connectors on this power supply which can furnish +30 VDC unregulated. The plug designated in the retrofit drawings is sometimes already being used by the liquid level control. It is permissible to daisy chain off this same wiring, or you may elect to utilize the alternate +30 VDC unregulated connection.

What Instructions do I use to install a retrofit OptiSpeed Compressor Drive?

There are 3 drawings shipped with each retrofit kit. These drawings are:

- Vane Pot Installation and Set-Up
- Piping Installation
- Control Panel Retrofit

How do I connect a 12 lead motor to a OptiSpeed Compressor Drive?

Most of these 12 lead motors actually have two sets of parallel windings, and therefore have two one's, two two's, etc. OSCD's and Solid-State Starters are connected to the motor in the delta configuration, that is 1&6, 2&4, 3&5. The T1 lug will then have two one's and two sixes tied to it.

There were a few motors, made several years ago, which were numbered 1 through 12. These motors had the first set of wires marked 1 to 6. Numbering then continued, with the second 1 numbered 7, the second 2 numbered 8, and so on, up to 12. In other words, take the numbers above six, subtract 6 from the number, and re-label as the result.

What is the Peak Input Voltage value?

The displayed value is the Phase to Neutral voltage at the input to the drive in terms of peak voltage, as would be measured with an oscilloscope.

Phase to neutral is normally the phase-to-phase voltage divided by the square root of three, or 265 VAC phase to neutral, for a 460 VAC system. The peak value of the 265 VAC measurement is approximately that number times the square root of two, or 375 volts in this example.

How do I reset the KWH Meter?

For the OptiView Control Panel, first enter the Service Access Level. Select the VSD Screen. Press the KWH key, and select the default selection. The KWH value will now be zero.

For the Micro Computer Control Center, first enter the "VSD Service Mode", making sure the Control Center is in "Program Mode", and pressing the "Operating Hours / Start Counter" button. The display will show, "Reset Hours? Y/N". Use the advance day / Scroll key to select "Y", and press "Enter". The KWH value will now be zero.

Is the Real Time Clock Chip on the microboard and the BRAM Chip on the ACC and OSCD logic boards the same chip?

If you are familiar with the RTC Clock chip used on the control center microboard, you may notice what appears to be clock chips on the ACC board and on the OSCD

logic board. These two boards contain similar black plastic chips which are battery backed random access memory (BRAM). They have a different number of pins from the RTC Clock chips, and cannot be replaced by the familiar clock chip.

When is a Booster Pump required on a Retrofit OptiSpeed Compressor Drive?

Detailed information is supplied in Form 160.05-N4. In general, the OSCD requires 8 ft of head for proper water flow to the OSCD heat exchanger. If this amount of head is not available, then a booster pump is required.

Can I apply an OptiSpeed Compressor Drive to a generator?

Yes, the OSCD can be applied to a generator. No modifications are required for a generator application. We have several OSCD installations running on generator power without difficulty. It is necessary that the generator's output voltage be maintained within the specified range of 414 to 508 VAC for a 460 VAC line, 360 to 440 for a 400 VAC line, or 517 to 632 VAC for a 575 VAC line and frequency be maintained within +/- 1 HZ (on all applications). This is usually not a problem for most generators, since motor current at startup is limited to less than 1X the Full Load Amps (FLA). The transfer of power between the utility and generator and back again must be delayed as to cause the chiller to fault and then restart. Not providing this delay may cause failure within the OSCD or instability within the generator.

My chiller will not slow down, why?

The OSCD will not reduce the motor speed until the leaving chilled water temperature is below +0.5 degree from setpoint. Once in this window, the speed still cannot be reduced until the operation is deemed to be stable, based upon the vanes are not continually moving open and closed to maintain temperature. This hunting effect is normally due to one of the following:

- Chilled liquid and Condenser liquid flows are not within the design range. The rate of change in flow maybe too fast for the chiller to be determined as stable.
- Return liquid temperature is varying due to 3-way valves or other system configuration, and the chiller is simply following changes in load.
- Vane stroke is too large. Remove the sensitivity jumper in the Micro Computer Control Center, or program a lower sensitivity on the OptiView Con-

trol Center. Also, check the vane motor to see that the fullest possible stroke is being utilized. Moving the vane motor arm pivot point closer to center, and extending the degrees of travel by adjusting the internal end stops, will reduce the amount of vane action for the same period of operation.

- Verify that the condenser tubes are clean.
- Verify that the liquid level control is working properly, and maintaining a refrigerant level in the condenser.
- Ensure that the condenser liquid temperature is proper for the load on the chiller. In many cases, the condenser liquid temperature is still at 85°F.

Failure to reduce speed may also be due to the system having been placed in Manual Speed when in VSD Service Mode. Other causes are a missing or disconnected wiring harness at ACC board J3, or a faulty ACC board itself.

What is the function of the Green LED on ACC Board?

This LED will light if:

- The system is in Manual speed control.
- The chiller is running in current limit.
- The leaving chilled liquid temperature is greater than +0.5 of setpoint.
- The rate of change in temperature of the leaving chilled water is greater than that programmed by the stability limit function.
- The chiller is not running.

I believe that the chiller is surging, but the surge counter is not increasing. What could be the problem?

When a surge is detected, the ACC board will light the red LED. Failure to light the red LED may be due to one of the following:

- The condition is “Stall”, Not Surge - Stall is a very noisy condition which is due to gas pulsations hitting the impeller wheel in a random fashion. System pressures and motor current may fluctuate in brief, random pulses, but this is not a surge. This is normal for a chiller that has reduced speed, but the condenser water temperature is too high. True surge will be characterized by a repeated howling sound, with pressure and motor current swinging in a cyclical manner.

- The wire harness connecting the ACC board J3 to the Micro-board may be missing or disconnected. This harness passes system pressure information to the ACC board.
- The ACC board may be defective.
- The chiller is not running.

Do I have a problem with my coolant? The pink color is no longer visible?

The coolant normally has a pink or rose color when new. After several months of operation, this color may dissipate, and the coolant may appear almost colorless. The lack of the color in the coolant does not necessarily indicate a problem. Most colorless samples test above 1000 PPM nitrite, which is normal. There is no need to flush the system unless you find the coolant becoming opaque or cloudy. In this case we suggest you obtain a sample for analysis, then flush the system with coolant and install fresh coolant. The coolant must be changed every year regardless of color or test results.

Why is the OSCD Circuit Breaker Tripping?

Circuit breaker tripping is now normal for a failed OptiSpeed Compressor Drive. This drive no longer contains input fuses. The AC choke now reduces the current flowing into the short, and the circuit breaker is now fast enough to provide proper protection. A tripped circuit breaker may be due to a shorted condition inside the drive, or the presence of a ground fault condition, or may be due to the breaker itself being faulty.

Check for shorts at the input and output of the drive. Check for leakage current to ground. This could also be a problem in one of the input SCR's. In some cases, the precharge current may cause the SCR to fail. It was determined in some applications the circuit breaker would trip because the input SCR was falsely turned on by a high rate of change in voltage on the input line. Snubbers were added across the input SCR to prevent this problem. Refer to form number 160.00-RP4 (406) or later for part numbers.

What is the TEST Button for on OSCD Logic Board?

When the OSCD is not running, this button may be used to test operation of the logic outputs from the OSCD logic board, as well as the operation of the gate driver board on the IGBT module. When this button is depressed, six output LEDs on the OSCD logic board alternately light the three plus (+) LEDs, then the

three minus (-) LEDs. At the same time, six LEDs on the gate driver board will alternate between dim and bright intensity. Several conditions can inhibit this test function:

- If any OSCD fault exists.
- If the unit is in pre-charge.
- If the SCR trigger is enabled.
- If the OSCD unit is running.
- A 4 minute timer is part of this function to ensure that the DC Link Voltage is discharged to a safe level. This timer must time out before the Test Button will function.

TROUBLESHOOTING AND COMPONENT REPLACEMENT PROCEDURES

General Information

The following procedures are designed to guide the service technician along the path that leads to the identification of the cause for the problem. The service technician should understand the operation of the OptiSpeed Compressor Drive and function of each major component. It is recommended that the service technician read and understand the information contained in this instruction prior to troubleshooting this product. Also, the service technician must understand the system interface, and be able to utilize system wiring diagrams to follow signal flow throughout the system. Due to the integration of the OptiSpeed Compressor Drive with the Graphic Control Center and Micro Computer Control Center, a good working knowledge of the Control Center is also necessary (Ref. Forms listed at the beginning of this form).

Several levels of documentation are required for the troubleshooting process. The OptiSpeed Compressor Drive wiring diagram, supplied with every OSCD is the top level document. It provides the overall wiring and configuration. Sections of this instruction provide the required lower levels. Specifically, block diagrams provide signal flow and simplified representations of all board circuitry.

Begin the troubleshooting process by selecting the appropriate procedure. It is not necessary to sequentially perform all of them. Perform a procedure only if there is a problem with that function.

Verify Failure of the OSCD Power Module 292/351/424 Hp Drive

General Information:



This product contains voltages that could cause injury! Before performing any of these procedures, place the compressor switch in the “stop” position. Wait 5 minutes. Ensure the DC bus voltage is 50 vdc or less on the display of the chiller panel. Remove all ac power sources and perform lockout tagout procedures. Use a non-contact voltage sensor to ensure no ac power is present in the enclosure. Measure the DC bus voltage at J3 pins 1-3 on the LCD logic board using a DVM to ensure the bus voltage is less than 50 VDC.

- Be certain the OSCD has been de-energized for over five minutes, and then double check for presence of voltage using a VOM. The DC bus must be fully discharged.
- It is not necessary to remove any wiring to perform this test.
- This test will be conducted for an analog meter and a digital meter. The analog meter must be adjusted to ohms on the Rx1 scale, and the meter should be adjusted for a 0 ohm reading with the probes connected together. The digital meter must be adjusted for the diode check. In this test we are not looking for an exact resistance measurements, but rather to verify if the semi-conductor switches are open or shorted.

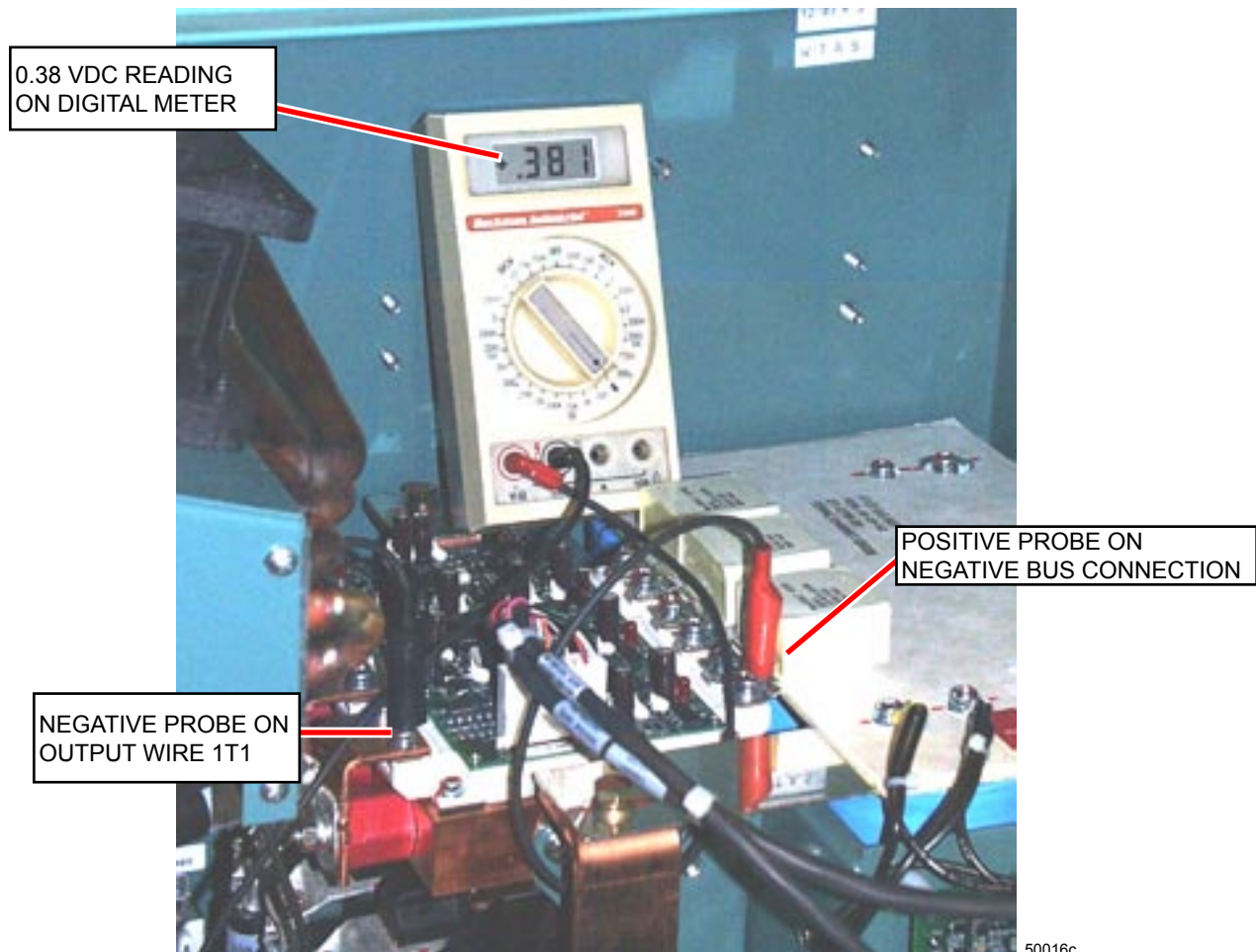

50016c

FIG. 14 - 292/351/424 HP DRIVE IGBT MODULE VERIFICATION #1

Test Procedure:

- Place the positive probe of the meter on the first right hand terminal of the IGBT module. This is the negative bus connection. Place the negative probe of the meter on the first left hand terminal of the IGBT module. The wire should be marked 1T1. The analog meter reading will be around 5-10 ohms. The digital meter reading will be around 0.36 VDC. Refer to Fig.14.

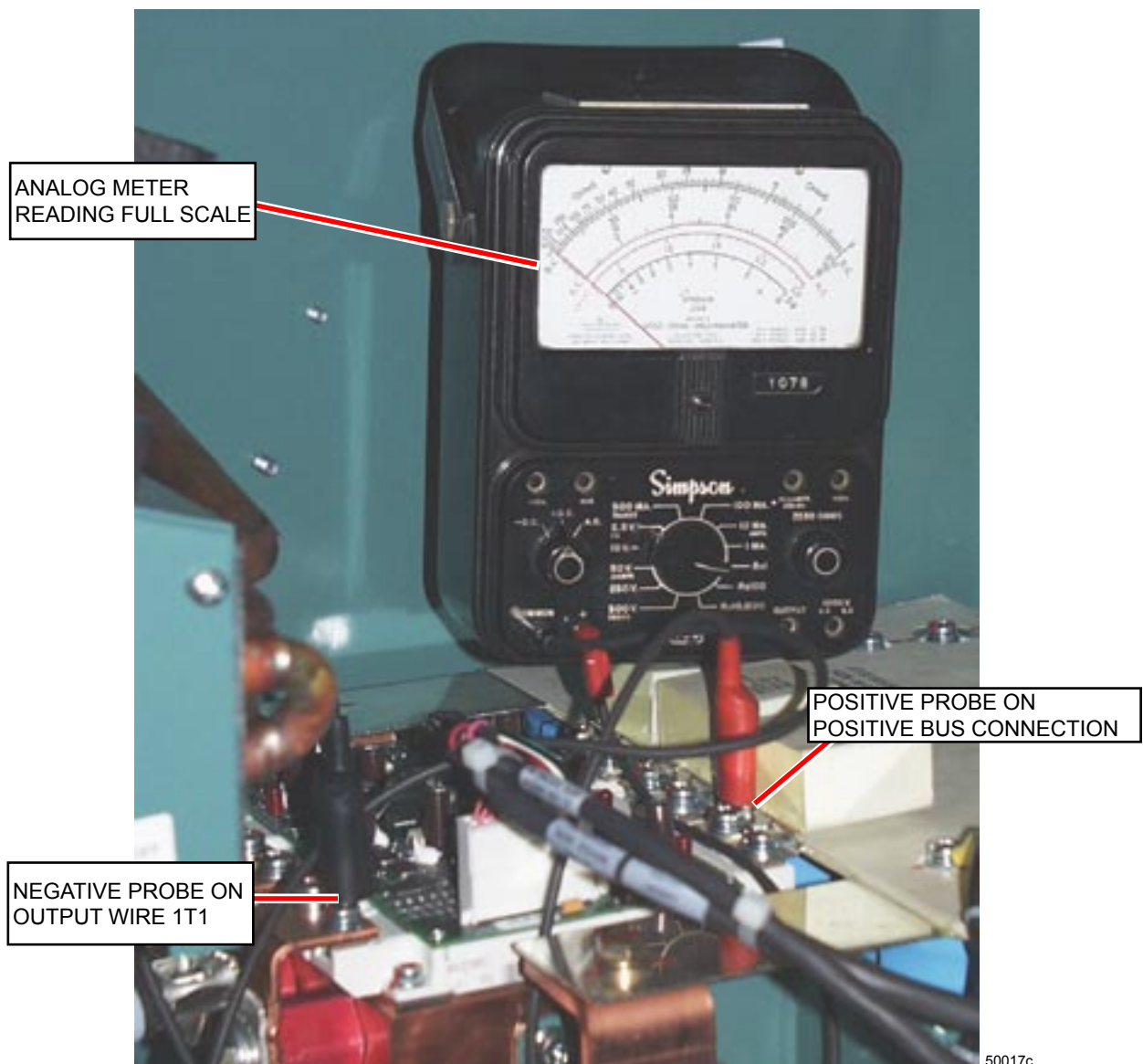

50017c

FIG. 15 - 292/351/424 HP DRIVE IGBT MODULE VERIFICATION #2.

- Place the positive probe of the meter on the second right hand terminal of the IGBT module. This is the positive bus connection. The analog meter reading will be near full scale to the left of the meter movement. The digital meter reading will be OL. These 2 readings will take several seconds for the meter to reach the suggested values. Refer to Figs.15 & 16
- Place the positive probe of the meter on the 3rd right hand terminal of the IGBT module. This is the negative bus connection. Place the negative probe of the meter on the 3rd left hand terminal of the IGBT module. The wire should be marked 1T2. The analog meter reading will be around 5-10 ohms. The digital meter reading will be around 0.36 VDC.

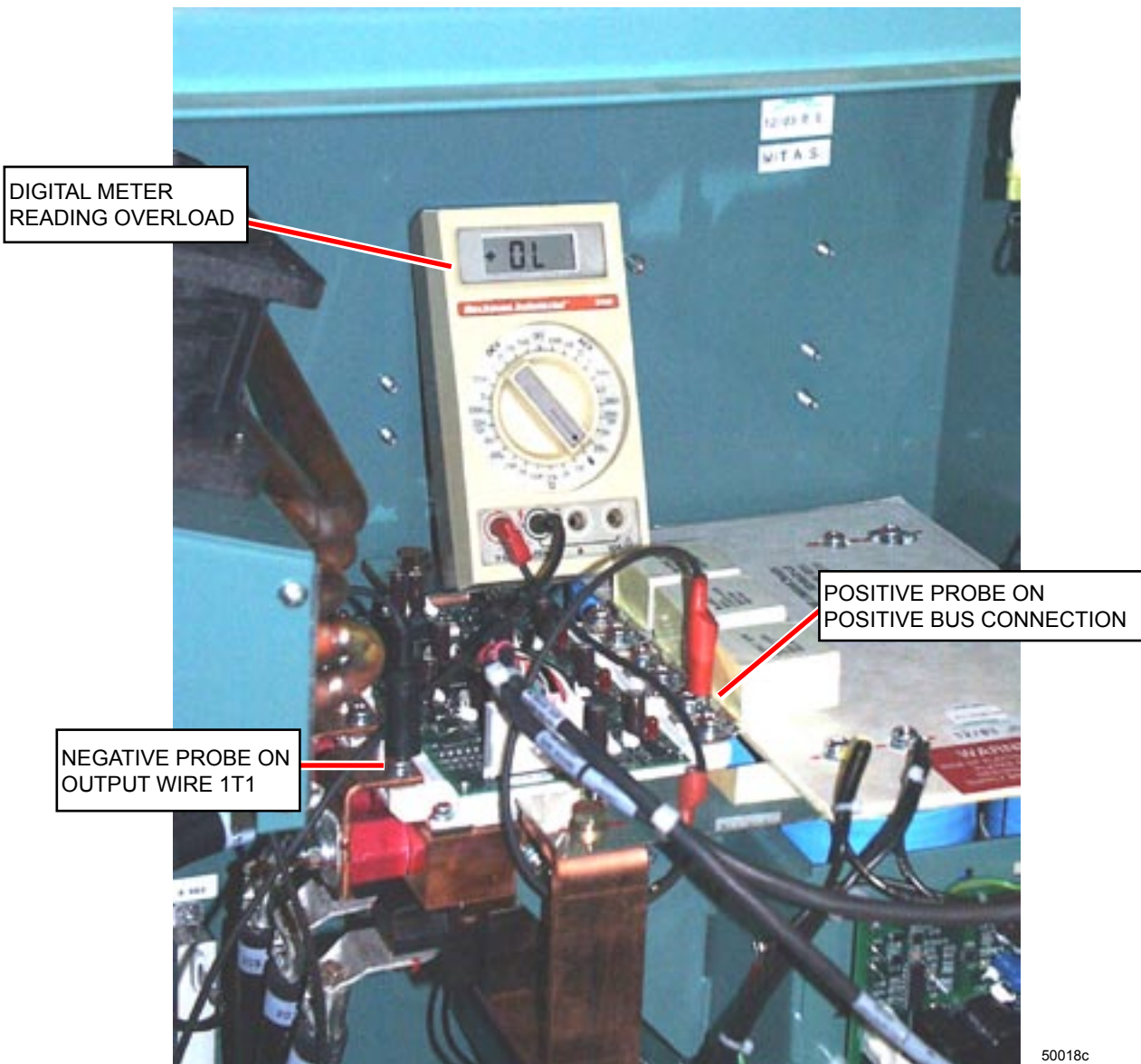

50018c

FIG. 16 - 292/352/424 HP DRIVE IGBT MODULE VERIFICATION #3.

- Place the positive probe of the meter on the 4th right hand terminal of the IGBT module. This is the positive bus connection. The analog meter reading will be near full scale to the left of the meter movement. The digital meter reading will be OL. These two readings will take several seconds for the meter to reach the suggested values.
- Place the positive probe of the meter on the 5th right hand terminal of the IGBT module. This is the negative bus connection. Place the negative probe of the meter on the 5th left hand terminal of the IGBT module. The wire should be marked 1T3. The analog meter reading will be around 5-10 ohms. The digital meter reading will be around 0.36 VDC.
- Place the positive probe of the meter on the 6th right hand terminal of the IGBT module. This is the positive bus connection. The analog meter reading will be near full scale to the left of the meter movement. The digital meter reading will be OL. These two readings will take several seconds for the meter to reach the suggested values.
- Repeat the above 6 steps, but reverse the location of the positive and negative probes of the meter. The readings will also be reverse as in where the reading are OL or full scale the readings will be 0.36 VDC or 5-10 ohms.
- If any one of the readings is not correct, then the IGBT module and gate driver board must be replaced.

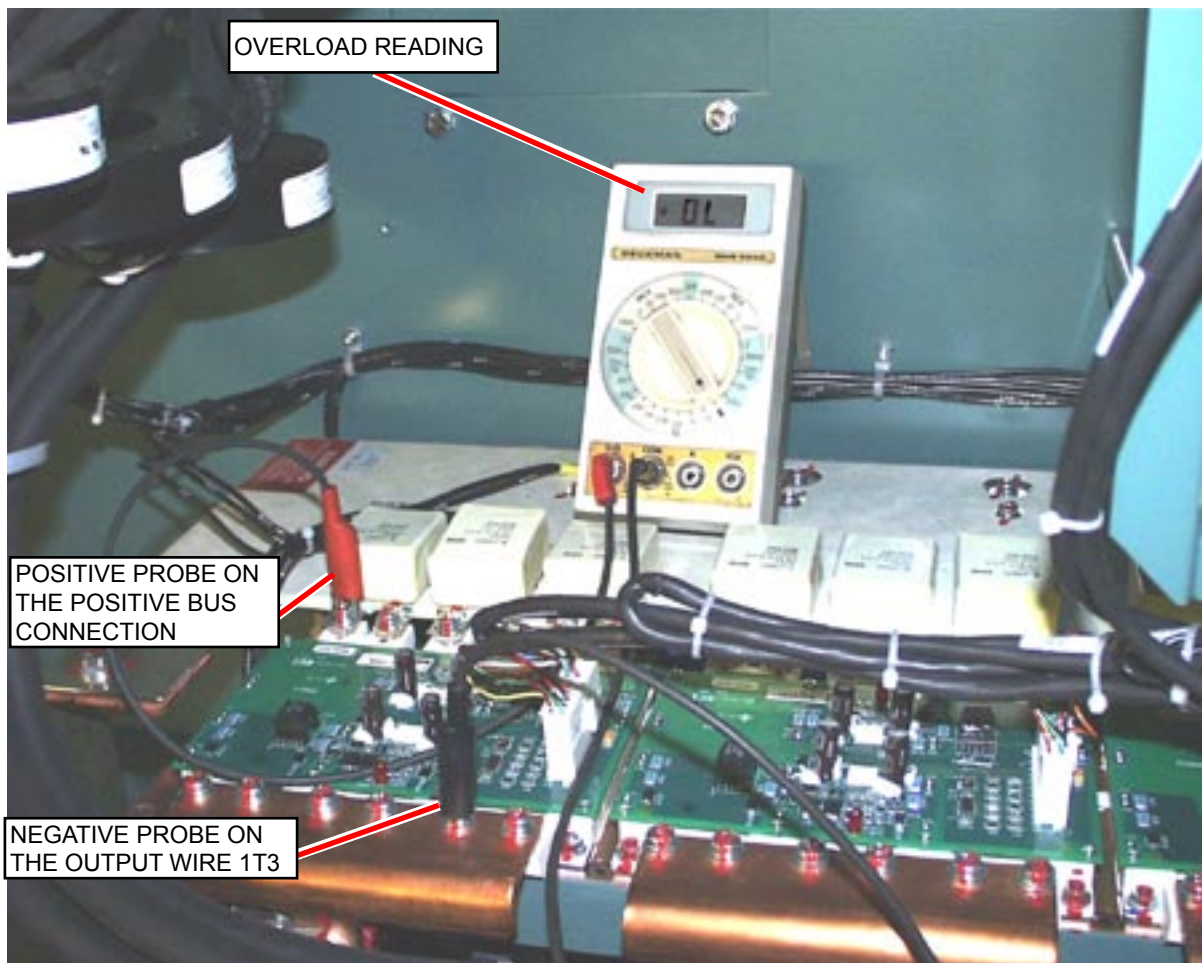

50019c

FIG 17 - 419/503/608 HP DRIVE IGBT MODULE VERIFICATION #1

Verify Failure of the OSCD Power Module 419/503/608 Hp Drive

General Information:

Refer to information under verify failure of the OSCD power module for general information.

Test Procedure:

- Place the positive probe of the meter on the first left hand terminal of the IGBT module. This is the positive bus connection. Place the negative probe of the meter on the large copper motor output connection of the IGBT module. The wire should be marked 1T3. The analog meter reading will be near full scale to the left of the meter movement. The digital meter reading will be OL. These 2 readings will take several seconds for the meter to reach the suggested values. Refer to Fig. 17.

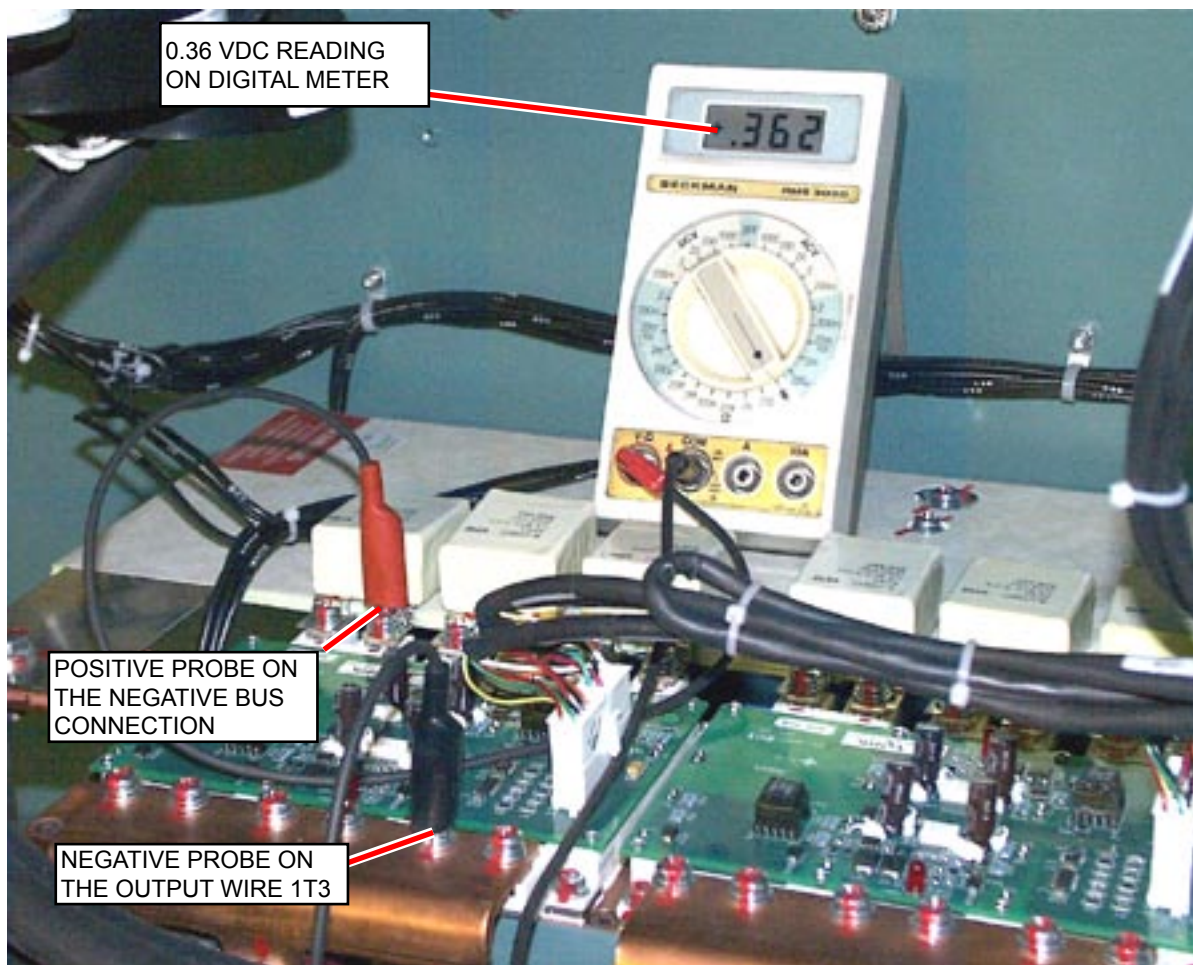

50020c

FIG. 18 - 419/503/608 HP DRIVE IGBT MODULE VERIFICATION #2

- Place the positive probe of the meter on the second left hand terminal of the IGBT module. This is the negative bus connection. The analog meter reading will be around 5-10 ohms. The digital meter reading will be around 0.36 VDC. Refer to Fig. 18.
- Place the positive probe of the meter on the first left hand terminal of the IGBT module. This is the positive bus connection. Place the negative probe of the meter on the large copper motor output connection large copper motor output connection of the IGBT module. The wire should be marked 1T2. The analog meter reading will be near full scale to the left of the meter movement. The digital meter reading will be OL. These two readings will take several seconds for the meter to reach the suggested values.

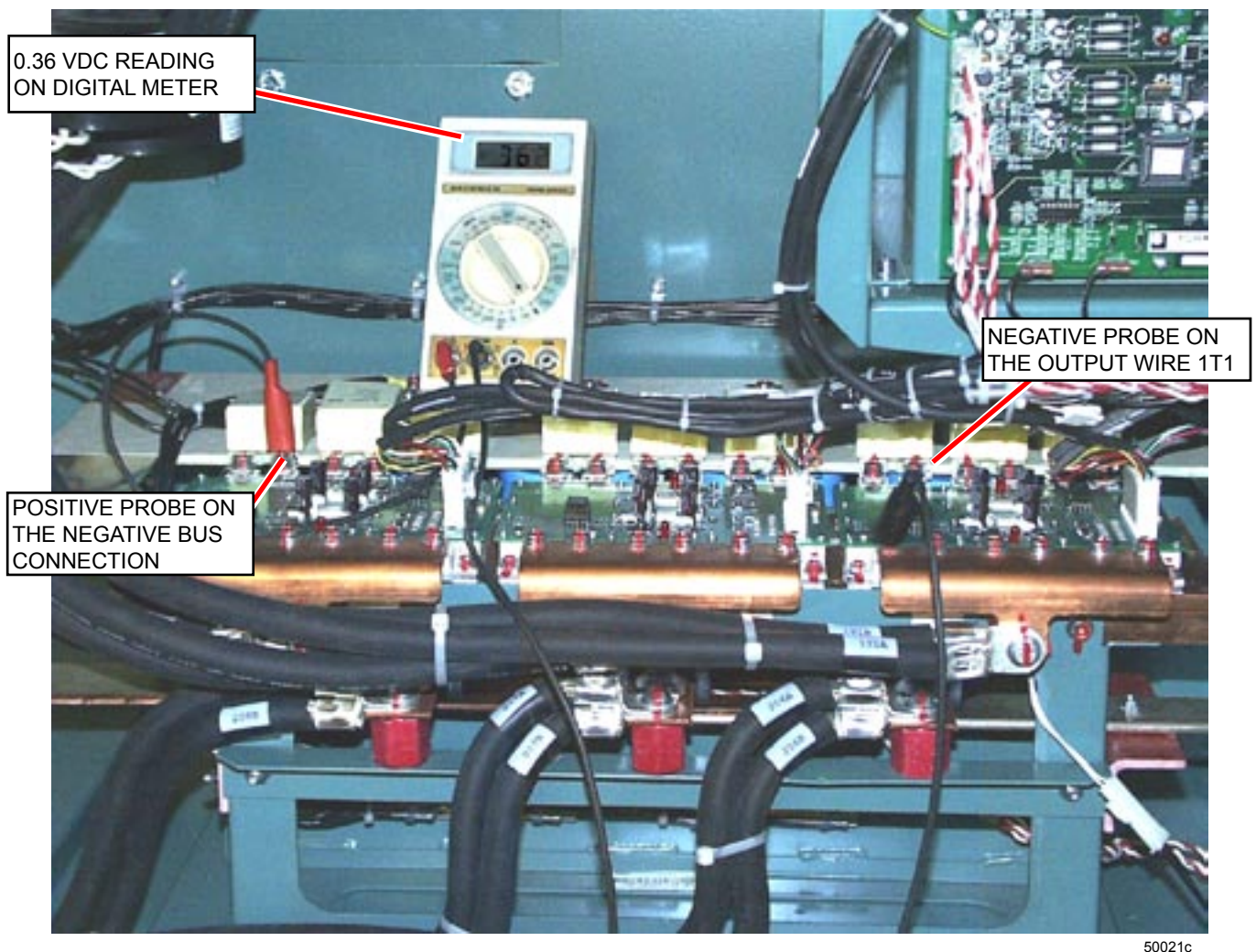

FIG. 19 - 419/503/608 HP DRIVE IGBT MODULE VERIFICATION #3

- Place the plus probe of the meter on the second left hand terminal of the IGBT module. This is the negative bus connection. The analog meter reading will be around 5-10 ohms. The digital meter reading will be around 0.36 VDC.
- Place the positive probe of the meter on the first left hand terminal of the IGBT module. This is the positive bus connection. Place the negative probe of the meter on the large copper motor output connection large copper motor output connection of the IGBT module. The wire should be marked 1T1. The analog meter reading will be near full scale to the left of the meter movement. The digital meter reading will be OL. These 2 readings will take several seconds for the meter to reach the suggested values.
- Place the positive probe of the meter on the second left hand terminal of the IGBT module. This is the negative bus connection. The analog meter reading will be around 5-10 ohms. The digital meter reading will be around 0.36 VDC. Refer to Fig. 19.
- Repeat the above steps, but reverse the location of the positive and negative probes of the meter. The readings will also be reverse as in where the reading are OL or full scale the readings will be 0.36 VDC or 5-10 ohms.
- If any one of the readings is not correct, then the IGBT module must be replaced.

Verify Failure of the Harmonic Filter Module 292/351/424 & 419/503/608Hp Drive

General Information:

Refer to information under verify failure of the OSCD power module for general information.

This test is the same for all horsepower drives. In the 292/351/424 Hp the harmonic filter power unit is mounted at the bottom right of the drive. In the 419/503/608 Hp the harmonic filter power unit is mounted at the center right of the drive. Refer to figures under the section for the 351/292 Hp for details.

Test Procedure:

- Place the positive probe of the meter on the first right hand terminal of the IGBT module. This is the negative bus connection. Place the negative probe of the meter on the first left hand terminal of the IGBT module. The wire should be marked 517. The analog meter reading will be around 5-10 ohms. The digital meter reading will be around 0.36 VDC.
- Place the positive probe of the meter on the second right hand terminal of the IGBT module. This is the positive bus connection. The analog meter reading will be near full scale to the left of the meter movement. The digital meter reading will be OL. These 2 readings will take several seconds for the meter to reach the suggested values.
- Place the positive probe of the meter on the 3rd right hand terminal of the IGBT module. This is the negative bus connection. Place the negative probe of the meter on the 3rd left hand terminal of the IGBT module. The wire should be marked 518. The analog meter reading will be around 5-10 ohms. The digital meter reading will be around 0.36 VDC.
- Place the positive probe of the meter on the 4th right hand terminal of the IGBT module. This is the positive bus connection. The analog meter reading will be near full scale to the left of the meter movement. The digital meter reading will be OL. These 2 readings will take several seconds for the meter to reach the suggested values.
- Place the positive probe of the meter on the 5th right hand terminal of the IGBT module. This is the negative bus connection. Place the negative probe of the meter on the 5th left hand terminal of the IGBT module. The wire should be marked 519. The analog meter reading will be around 5-10 ohms. The digital meter reading will be around 0.36 VDC.
- Place the positive probe of the meter on the 6th right hand terminal of the IGBT module. This is the positive bus connection. The analog meter reading will be near full scale to the left of the meter movement. The digital meter reading will be OL. These 2 readings will take several seconds for the meter to reach the suggested values.
- Repeat the above 6 steps, but reverse the location of the positive and negative probes of the meter. The readings will also be reverse as in where the reading are OL or full scale the readings will be 0.36 VDC or 5-10 ohms.
- If any one of the readings is not correct, then the IGBT module must be replaced.

Replacement of the OSCD Power Module

The following step by step procedure includes several helpful hints which should make the process easier, and minimize the possibility of damage to other components or to the OSCD.

Save all of the packing material. This material is to be re-used when returning a defective power module as required for warranty.



This product contains voltages that could cause injury! Before performing any of these procedures, place the compressor switch in the “stop” position. Wait 5 minutes. Ensure the dc bus voltage is 50 vdc or less on the display of the chiller panel. Remove all ac power sources and perform lockout tagout procedures. Use a non-contact voltage sensor to ensure no ac power is present in the enclosure. Measure the dc bus voltage at j3 pins 1-3 on the led logic board using a dvm to ensure the bus voltage is less than 50 vdc.

- Be certain the OSCD has been de-energized for over five minutes, and then double check for presence of voltage using a VOM. The DC bus must be fully discharged.
- 292/351/424 Hp Drive Only:** Drain the coolant from the heat exchanger into a suitable container and discard.

- Remove the connector on the IGBT Gate Driver Board.
- Remove and discard the 6 Phillips head screws from the power wire connector tang or tangs, and the remaining 6 Phillips head screws from the bus connections.
- Remove the bolt holding the power wire to the output of the IGBT.
- Remove and discard the 8 Allen screws from the IGBT module.
- **292/351/424 Hp Drive Only:** Carefully remove the OSCD power module by sliding it away from the bus structure while lifting slightly. **DO NOT** place any stress on the bus structure. The bottom of the IGBT module will be wet. Ensure that the coolant does not drip onto any other components inside of the OSCD enclosure. This coolant is **conductive**, and as little as one drop falling on the Harmonic Filter gate driver board can cause it to fail!
- **292/351/424 Hp Drive Only:** Remove the 3 O-rings from the copper chill plate and discard them.
- **292/351/424 Hp Drive Only:** Wipe the chill plate clean with a clean soft cloth. **DO NOT** leave lint or any materials on the chill plate. **DO NOT** clean using compressed air.
- **292/351/424 Hp Drive Only:** Lightly lubricate the new O-rings with O-ring lubricant. Provided in the kit.
- **292/351/424 Hp Drive Only:** Install the new O-rings into the chill plate grooves.
- **292/351/424 Hp Drive Only:** Place the new OSCD power module on the chill plate so that the connector is towards the front of the OSCD enclosure. Carefully slide the OSCD power module power connections under the bus structure. The replacement assembly should still be loose.
- **419/503/608 Hp Drive Only:** Carefully remove the OSCD power module by sliding it away from the bus structure while lifting slightly. **DO NOT** place any stress on the bus structure.
- **419/503/608 Hp Drive Only:** Wipe the chill plate clean with a clean soft cloth. **DO NOT** leave lint or any materials on the chill plate. **DO NOT** clean using compressed air. Rubbing alcohol works well to remove the thermal grease from the chill plate.
- **419/503/608 Hp Drive Only:** Apply a thin coat of thermal grease on to the back side of the IGBT module. The thermal grease should be provided in the service kit.
- **419/503/608 Hp Drive Only:** Place the new OSCD power module on the chill plate so that the connector is towards the right of the OSCD enclosure. Carefully slide the OSCD power module power connections under the bus structure. The replacement assembly should still be loose.
- Insert the 8 Allen head screws through the new IGBT module and engage a few threads in the chill plate, but **DO NOT** tighten. The new OSCD power module should still be loose.
- Align the OSCD power module so that 6 of the Phillips head screws can be installed through the bus structure and into the IGBT module. **DO NOT** tighten these screws.
- Tighten the Allen head screws to 48 in.-lbs. (5.5 Nm) \pm 10% in the sequence shown in Fig. 20.

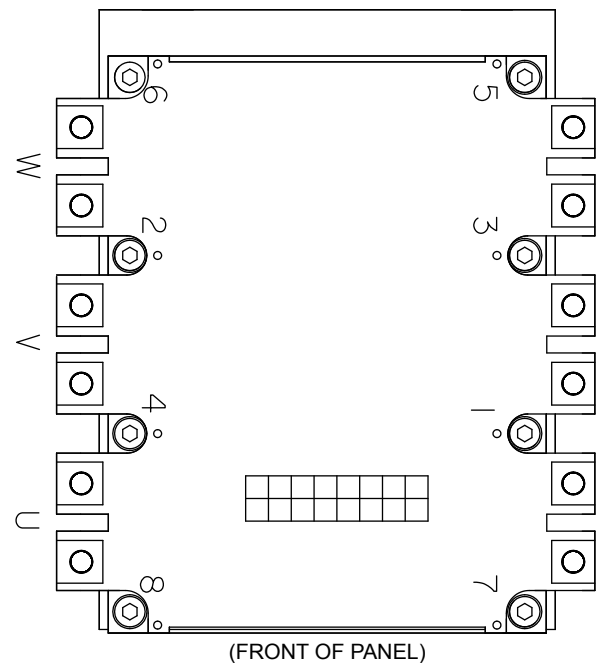

SCREWS TO BE TORQUED IN SEQUENCE - 1, 2, 3, 4, 5, 6, 7, 8
LD07412

FIG. 20 - OSCD POWER MODULE

- Install the power wire connector tang or tangs using 6 Phillips head screws, and torque the screws to 48 in.-lbs. (5.5 Nm) \pm 10%. If a copper output power tang or tangs are used install them with the bolt that was saved. Torque the bolt to 40-50 in.-lbs. Then install the 6 Phillips head screws, and torque the screws to 48 in.-lbs. (5.5 Nm) \pm 10%.
- Remove the 6 Phillips head screws (not yet tightened) at the bus structure and install the 3 square capacitors to the bus structures with these screws. Torque the screws to 48 in.-lbs. (5.5 Nm) \pm 10%.
- Install the connector on the IGBT Gate Driver Board.
- **292/351/424 Hp Drive Only:** Close the drain valve on the heat exchanger and refill the system with the coolant supplied and check for leaks.
- **292/351/424 Hp Drive Only:** Follow the directions included in the Start-Up Preparations for running the OSCD's water pump to ensure all entrapped air is vented and the cooling loop is properly filled.

Replacement of the Harmonic Filter Power Module

The procedure to replace the harmonic filter power module is the same as for the replacement of the OSCD Power Module, except for the following.

- **292/351/424 Hp Drive Only:** On early models of the OSCD compressor drive the cooling system did not properly drain out of the Harmonic Filter Power Module. Early models can be determined by look at the far end of the heat exchanger. If the three hoses are connected to a 6 inch plastic riser pipe, then this is the style that will not properly drain.
- **292/351/424 Hp Drive Only:** Drain the coolant as described above. Then remove one of the coolant hoses feeding the Harmonic Filter Power Module. Failure to completely drain the coolant system will cause coolant to leak into the VSD enclosure.
- **419/503/608 Hp Drive Only:** The IGBT module for the harmonic filter power unit is installed in the same manner as the 292/351/424 Hp drive, but will not have the draining problems.

In-Warranty Parts Return – Any OSCD parts failing within the standard warranty period must be returned. Refer to YORK Warranty Return Policy for instructions.

SOFTWARE REFERENCE LIST 60 HZ ONLY

OptiView Control Center Minimum Versions Required for the 351 Hp Drive

<u>Location</u>	<u>Part Number</u>	<u>Minimum Version Number</u>
Microboard U45	031-01796-003	C.MLM.00.03
YT Microboard U46	031-02004-001	C.MLM.02.02B.102
YK Microboard U46	031-01797-001	C.MLM.01.05B.102
YKP Microboard U46	031-02073-001	C.MLM.04.01B.100
ACC Board U22	031-01674-002	C.ACC.01.03
OSCD Logic Board U34	031-01617-006	C.VSD.01.10
OSCD Logic Board U40	031-01619-003	C.VSD.03.02
OSCD Logic Board U45	031-01618-001	C.VSD.02.02
Filter Logic Board U26	031-01680-003	C.FTR.02.05
Filter Logic Board U42	031-01633-006	C.FTR.01.14

OptiView Control Center Minimum Versions Required for the 424/608 Hp Drive (for 031-02430-000 board only)

<u>Location</u>	<u>Part Number</u>	<u>Minimum Version Number</u>
YT Microboard U46	031-02469-001	C.OPT.02.09.008
YK & YKP Microboard U46	031-02474-001	C.OPT.01.15A.307
Microboard U45	031-01796-003	C.MLM.00.03
ACC Board U22	031-01674-002	C.ACC.01.03
OSCD Logic Board U34	031-01617-009	C.VSD.01.23
OSCD Logic Board U40	031-01619-003	C.VSD.03.04
OSCD Logic Board U45	031-01618-001	C.VSD.02.02
Filter Logic Board U26	031-01680-003	C.FTR.02.05
Filter Logic Board U42	031-01633-008	C.FTR.01.20

OptiView Control Center Minimum Versions Required for the 503 Hp Drive

<u>Location</u>	<u>Part Number</u>	<u>Minimum Version Number</u>
YT Microboard U46	031-02004-001	C.MLM.02.04.104
YK & YKP Microboard U46	031-01797-001	C.MLM.01.08.105
Microboard U45	031-01796-003	C.MLM.00.03
ACC Board U22	031-01674-002	C.ACC.01.03
OSCD Logic Board U34	031-01617-006	C.VSD.01.13A
OSCD Logic Board U40	031-01619-003	C.VSD.03.04
OSCD Logic Board U45	031-01618-001	C.VSD.02.02
Filter Logic Board U26	031-01680-003	C.FTR.02.05
Filter Logic Board U42	031-01633-006	C.FTR.01.18

Micro Computer Control Center Versions Required for the 351 Hp Drive

<u>Location</u>	<u>Part Number</u>	<u>Minimum Version Number</u>
YT Microboard U17	031-01676-003	C.YTV.05.20
YK Microboard U17	031-01675-003	C.YKV.06.24
ACC Board U22	031-01674-002	C.ACC.01.03
OSCD Logic Board U34	031-01617-006	C.VSD.01.10
OSCD Logic Board U40	031-01619-003	C.VSD.03.02
OSCD Logic Board U45	031-01618-001	C.VSD.02.02
Filter Logic Board U26	031-01680-003	C.FTR.02.05
Filter Logic Board U42	031-01633-006	C.FTR.01.14

Micro Computer Control Center Versions Required for the 424/608 Hp Drive

<u>Location</u>	<u>Part Number</u>	<u>Minimum Version Number</u>
YT Microboard U17	031-01676-003	C.YTV.05.24
YK Microboard U17	031-01675-003	C.YKV.06.32
ACC Board U22	031-01674-002	C.ACC.01.03
OSCD Logic Board U34	031-01617-009	C.VSD.01.23
OSCD Logic Board U40	031-01619-003	C.VSD.03.04
OSCD Logic Board U45	031-01618-001	C.VSD.02.02
Filter Logic Board U26	031-01680-003	C.FTR.02.05
Filter Logic Board U42	031-01633-008	C.FTR.01.20

Micro Computer Control Center Versions Required for the 503 Hp Drive

<u>Location</u>	<u>Part Number</u>	<u>Minimum Version Number</u>
YT Microboard U17	031-01676-003	C.YTV.05.22
YK Microboard U17	031-01675-003	C.YKV.06.30
ACC Board U22	031-01674-002	C.ACC.01.03
OSCD Logic Board U34	031-01617-006	C.VSD.01.13A
OSCD Logic Board U40	031-01619-003	C.VSD.03.04
OSCD Logic Board U45	031-01618-001	C.VSD.02.02
Filter Logic Board U26	031-01680-003	C.FTR.02.05
Filter Logic Board U42	031-01633-006	C.FTR.01.18

SOFTWARE REFERENCE LIST 50 HZ ONLY

OptiView Control Center Minimum Versions Required for the 292 Hp Drive

<u>Location</u>	<u>Part Number</u>	<u>Minimum Version Number</u>
Microboard U45	031-01796-003	C.MLM.00.03
YT Microboard U46	031-02004-001	C.MLM.02.02B.102
YK Microboard U46	031-01797-001	C.MLM.01.05B.102
YKP Microboard U46	031-02073-001	C.MLM.04.01B.100
ACC Board U22	031-01674-002	C.ACC.01.03
OSCD Logic Board U34	031-01617-007	C.VSD.01.14A
OSCD Logic Board U40	031-01619-003	C.VSD.03.02
OSCD Logic Board U45	031-01618-002	C.VSD.02.03
Filter Logic Board U26	031-01680-003	C.FTR.02.05
Filter Logic Board U42	031-01633-007	C.FTR.01.15

OptiView Control Center Minimum Versions Required for the 419 Hp Drive

<u>Location</u>	<u>Part Number</u>	<u>Minimum Version Number</u>
Microboard U45	031-01796-003	C.MLM.00.03
YT Microboard U46	031-02004-001	C.MLM.02.04.104
YK & YKP Microboard U46	031-01797-001	C.MLM.01.08.105
ACC Board U22	031-01674-002	C.ACC.01.03
OSCD Logic Board U34	031-01617-007	C.VSD.01.14A
OSCD Logic Board U40	031-01619-003	C.VSD.03.04
OSCD Logic Board U45	031-01618-002	C.VSD.02.03
Filter Logic Board U26	031-01680-003	C.FTR.02.05
Filter Logic Board U42	031-01633-007	C.FTR.01.19

Micro Computer Control Center Versions Required for the 292 Hp Drive

<u>Location</u>	<u>Part Number</u>	<u>Minimum Version Number</u>
YT Microboard U17	031-01676-002	C.YTV.05.21
YK Microboard U17	031-01675-002	C.YKV.06.23
ACC Board U22	031-01674-002	C.ACC.01.03
OSCD Logic Board U34	031-01617-007	C.VSD.01.14A
OSCD Logic Board U40	031-01619-003	C.VSD.03.02
OSCD Logic Board U45	031-01618-002	C.VSD.02.03
Filter Logic Board U26	031-01680-003	C.FTR.02.05
Filter Logic Board U42	031-01633-007	C.FTR.01.15

Micro Computer Control Center Versions Required for the 419 Hp Drive

<u>Location</u>	<u>Part Number</u>	<u>Minimum Version Number</u>
YT Microboard U17	031-01676-002	C.YTV.05.23
YK Microboard U17	031-01675-002	C.YKV.06.29
ACC Board U22	031-01674-002	C.ACC.01.03
OSCD Logic Board U34	031-01617-007	C.VSD.01.14A
OSCD Logic Board U40	031-01619-003	C.VSD.03.04
OSCD Logic Board U45	031-01618-002	C.VSD.02.03
Filter Logic Board U26	031-01680-003	C.FTR.02.05
Filter Logic Board U42	031-01633-007	C.FTR.01.19

