



TECHNICAL SERVICE MANUAL

HEAVY-DUTY BRACKET MOUNTED PUMPS
 SERIES 4193 AND 493
 SIZES GG - AL

SECTION	TSM 154
PAGE	1 OF 10
ISSUE	C

CONTENTS

Introduction	1
Special Information	2
Special Mechanical Seals	2
Disassembly	3
Assembly	5
Thrust Bearing Adjustment	7
Installation of Carbon Graphite Bushings	7
Pressure Relief Valve Instructions	7

INTRODUCTION

The illustrations used in this manual are for identification purposes only and cannot be used for ordering parts. Obtain a parts list from the factory or a Viking® representative. Always give complete name of part, part number and material with model number and serial number of pump when ordering repair parts. The unmounted pump or pump unit model number and serial number are on the nameplate.

In the Viking model number system, basic size letters are combined with series number (4193 and 493) are used to indicate either an unmounted pump or mounted pump unit.

UNMOUNTED PUMP	UNITS
Foot Mounted	
GG4193	Units are designated by the unmounted pump model numbers followed by a letter(s) indicating drive style. D = Direct Drive
HJ4193	
HL4193	
AS4193	
AK4193	
AL4193	
Flange Mounted	
GG493	M = Horizontal Direct Drive
HJ493	IM = Vertical In-Line Direct Drive
HL493	IOM = Vertical In-Line Direct Drive with Piping Support Hangers
AS493	
AK493	
AL493	

This manual deals only with Series 4193 and 493 Heavy Duty Pumps. Refer to Figures 1 through 14 for general configuration and nomenclature used in this manual. Pump specifications and recommendations are listed in Catalog Section 154, Series 4193 and 493 Heavy Duty Pumps.



FIGURE 1
GG, HJ and HL4193 SERIES
 Foot Type Unmounted Pump with Flanged Ports

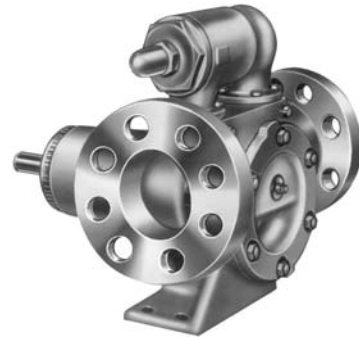

FIGURE 2
AS, AK and AL4193 SERIES
 Foot Type Unmounted Pump with Flanged Ports



FIGURE 3
GG, HJ and HL493 SERIES
 Unmounted Pump with Flanged Ports

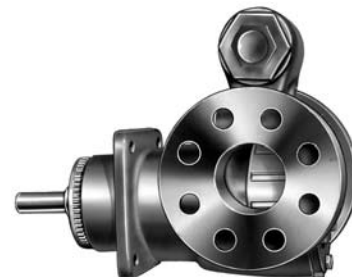

FIGURE 4
AS, AK and AL493 SERIES
 Unmounted Pump with Flanged Ports



SAFETY INFORMATION AND INSTRUCTIONS

IMPROPER INSTALLATION, OPERATION OR MAINTENANCE OF PUMP MAY CAUSE SERIOUS INJURY OR DEATH AND/OR RESULT IN DAMAGE TO PUMP AND/OR OTHER EQUIPMENT. VIKING'S WARRANTY DOES NOT COVER FAILURE DUE TO IMPROPER INSTALLATION, OPERATION OR MAINTENANCE.

THIS INFORMATION MUST BE FULLY READ BEFORE BEGINNING INSTALLATION, OPERATION OR MAINTENANCE OF PUMP AND MUST BE KEPT WITH PUMP. PUMP MUST BE INSTALLED, OPERATED AND MAINTAINED ONLY BY SUITABLY TRAINED AND QUALIFIED PERSONS.

THE FOLLOWING SAFETY INSTRUCTIONS MUST BE FOLLOWED AND ADHERED TO AT ALL TIMES.

Symbol Legend :



Danger - Failure to follow the indicated instruction may result in serious injury or death.

WARNING

Warning - In addition to possible serious injury or death, failure to follow the indicated instruction may cause damage to pump and/or other equipment.



BEFORE opening any liquid chamber (pumping chamber, reservoir, relief valve adjusting cap fitting, etc.) be sure that :

- Any pressure in the chamber has been completely vented through the suction or discharge lines or other appropriate openings or connections.
- The pump drive system means (motor, turbine, engine, etc.) has been "locked out" or otherwise been made non-operational so that it cannot be started while work is being done on the pump.
- You know what material the pump has been handling, have obtained a material safety data sheet (MSDS) for the material, and understand and follow all precautions appropriate for the safe handling of the material.

WARNING

INSTALL pressure gauges/sensors next to the pump suction and discharge connections to monitor pressures.



WARNING

USE extreme caution when lifting the pump. Suitable lifting devices should be used when appropriate. Lifting eyes installed on the pump must be used **only** to lift the pump, **not** the pump with drive and/or base plate. If the pump is mounted on a base plate, the base plate must be used for all lifting purposes. If slings are used for lifting, they must be safely and securely attached. For weight of the pump alone (which does not include the drive and/or base plate) refer to the Viking Pump product catalog.



BEFORE operating the pump, be sure all drive guards are in place.



DO NOT attempt to dismantle a pressure relief valve that has not had the spring pressure relieved or is mounted on a pump that is operating.



DO NOT operate pump if the suction or discharge piping is not connected.



AVOID contact with hot areas of the pump and/or drive. Certain operating conditions, temperature control devices (jackets, heat-tracing, etc.), improper installation, improper operation, and improper maintenance can all cause high temperatures on the pump and/or drive.



DO NOT place fingers into the pumping chamber or its connection ports or into any part of the drive train if there is **any possibility** of the pump shafts being rotated.



WARNING

THE PUMP must be provided with pressure protection. This may be provided through a relief valve mounted directly on the pump, an in-line pressure relief valve, a torque limiting device, or a rupture disk. If pump rotation may be reversed during operation, pressure protection must be provided on **both** sides of pump. Relief valve adjusting screw caps must always point towards suction side of the pump. If pump rotation is reversed, position of the relief valve must be changed. Pressure relief valves cannot be used to control pump flow or regulate discharge pressure. For additional information, refer to Viking Pump's Technical Service Manual TSM 000 and Engineering Service Bulletin ESB-31.

WARNING

DO NOT exceed the pumps rated pressure, speed, and temperature, or change the system/duty parameters from those the pump was originally supplied, without confirming its suitability for the new service.



WARNING

BEFORE operating the pump, be sure that:

- It is clean and free from debris
- all valves in the suction and discharge pipelines are fully opened.
- All piping connected to the pump is fully supported and correctly aligned with the pump.
- Pump rotation is correct for the desired direction of flow.



WARNING

THE PUMP must be installed in a matter that allows safe access for routine maintenance and for inspection during operation to check for leakage and monitor pump operation.

SPECIAL INFORMATION

DANGER !

Before opening any Viking pump liquid chamber (pumping chamber, reservoir, relief valve adjusting cap fitting, etc.) Be sure:

1. That any pressure in the chamber has been completely vented through the suction or discharge lines or other appropriate openings or connections.
2. That the driving means (motor, turbine, engine, etc.) has been "locked out" or made non-operational so that it cannot be started while work is being done on pump.
3. That you know what liquid the pump has been handling and the precautions necessary to safely handle the liquid. Obtain a material safety data sheet (MSDS) for the liquid to be sure these precautions are understood.

Failure to follow above listed precautionary measures may result in serious injury or death.

ROTATION: Viking pumps operate equally well in a clockwise or counterclockwise rotation. Shaft rotation determines which port is suction and which is discharge. Port in area where pumping elements (gear teeth) come out of mesh is Suction Port.

PRESSURE RELIEF VALVES:

1. Viking pumps are positive displacement pumps and must be provided with some sort of pressure protection. This may be a relief valve mounted directly on the pump, an inline pressure relief valve, a torque limiting device or a rupture disk.
2. There are relief valve options available on these pumps. Relief valve options include an internal relief valve and a return to tank valve.
3. If pump rotation is to be reversed during operation, pressure protection must be provided on **both** sides of pump.
4. Relief valve adjusting screw cap must always point towards suction side of pump. If pump rotation is reversed, remove pressure relief valve and turn end for end. **Refer to Figure 5.**
5. Pressure relief valves should not be used to control pump flow or regulate discharge pressure.

For additional information on pressure relief valves, refer to Technical Service Manual TSM 000 and Engineering Service Bulletin ESB-31.

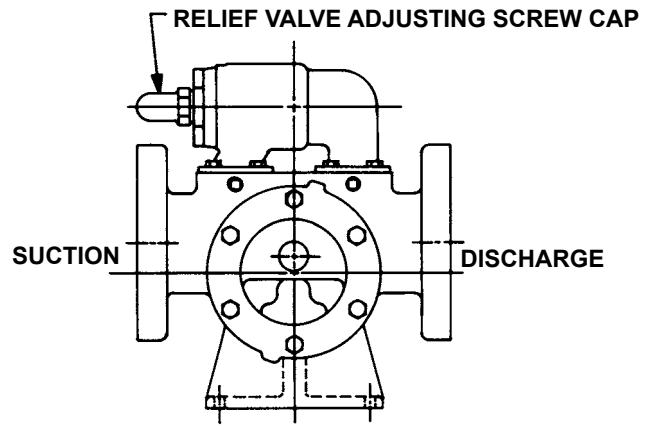

FIGURE 5

SPECIAL MECHANICAL SEALS

Extra care should be taken in repair of these pumps. Be sure to read and follow all special instructions supplied with your pump.

MAINTENANCE

Series 4193 and 493 pumps are designed for long, trouble-free service life under a wide variety of application conditions with a minimum of maintenance. The points listed below will help provide long service life.

CLEANING PUMP: Keep pump as clean as possible. This will facilitate inspection, adjustment and repair work and help prevent overlooking a dirt covered grease fitting.

STORAGE: If the pump is to be stored, or not used for six months or more, the pump must be drained and a light coat of non-detergent SAE 30 weight oil must be applied to all internal pump parts. Lubricate the fittings and apply grease to the pump shaft extension. Viking suggests rotating the pump shaft by hand one complete revolution every 30 days to circulate the oil.

SUGGESTED REPAIR TOOLS: The following tools must be available to properly repair Series 4193 and 493 pumps. These tools are in addition to standard mechanics' tools such as open end wrenches, pliers, screw drivers, etc. Most of the items can be obtained from an industrial supply house.

1. Soft Headed hammer
2. Allen wrenches (set screws & special mechanical seals)
3. Snap Ring Pliers
INTERNAL – Viking P/N 2-810-047-999
GG-HJ-HL 4193-493
EXTERNAL – Viking P/N 2-810-029-375
GG-HJ-HL 4193-493
4. Mechanical Seal Installation Sleeve
2-751-001-730 for 0.75 inch seal; GG 4193-493
2-751-004-730 for 1.25 inch seal; AS-AL 4193-493
5. Bearing Locknut Spanner Wrench
2-810-043-375-00
6. Spanner Wrench, adjustable pin type for use on bearing housing end cap.
2-810-008-375-00
7. Brass bar
8. Arbor press
9. Standard 5/16" 12 point socket.

DISASSEMBLY

DANGER !

Before opening any Viking pump liquid chamber (pumping chamber, reservoir, relief valve adjusting cap fitting, etc.)
Be sure:

1. That any pressure in the chamber has been completely vented through the suction or discharge lines or other appropriate openings or connections.
2. That the driving means (motor, turbine, engine, etc.) has been "locked out" or made non-operational so that it cannot be started while work is being done on pump.
3. That you know what liquid the pump has been handling and the precautions necessary to safely handle the liquid. Obtain a material safety data sheet (MSDS) for the liquid to be sure these precautions are understood.

Failure to follow above listed precautionary measures may result in serious injury or death.

1. Refer to figures 7 & 8 on page 4 for model to be disassembled and name of parts. Models 4193 & 493 are disassembled and assembled the same. The difference between these models is the casings.
2. Mark the head and casing before disassembly to ensure proper reassembly.
3. **NOTE:** The four valve capscrews, valve and gasket must be removed from the GG 4193-493 model before the six head capscrews are removed.
Remove the head capscrews.
4. Remove the head from the pump. Do not allow the idler to fall from the idler pin. Tilt the top of the head back when removing to prevent this. Avoid damaging the head gasket.
5. Remove the idler and bushing assembly. If the the idler bushing needs replacing, see "Installation of Carbon Graphite Bushings", page 7.
6. Remove the locknut from the shaft. See Figure 9 or 10. A brass bar or piece of hardwood inserted in the port opening and between the rotor teeth will keep the shaft from turning.
7. Loosen the two setscrews in the face of the bearing housing and turn the thrust bearing assembly counterwise and remove from the casing. See Figure 9 or 10.
8. Remove the snap ring from the shaft for GG, HJ and HL size pumps. See Figure 9.
9. Remove the bearing spacer from the shaft for AS, AK and AL size pumps. See Figure 10.
10. Remove the brass bar or piece of hardwood from the port opening.

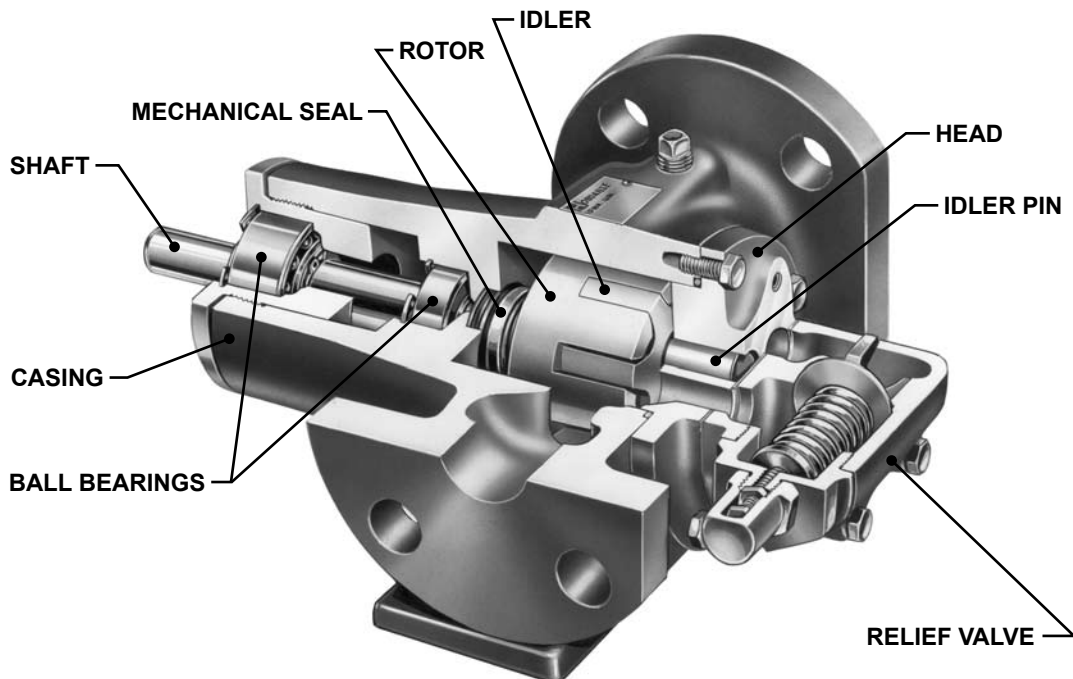

FIGURE 6
CUTAWAY FOR MODELS GG, HJ AND HL4193

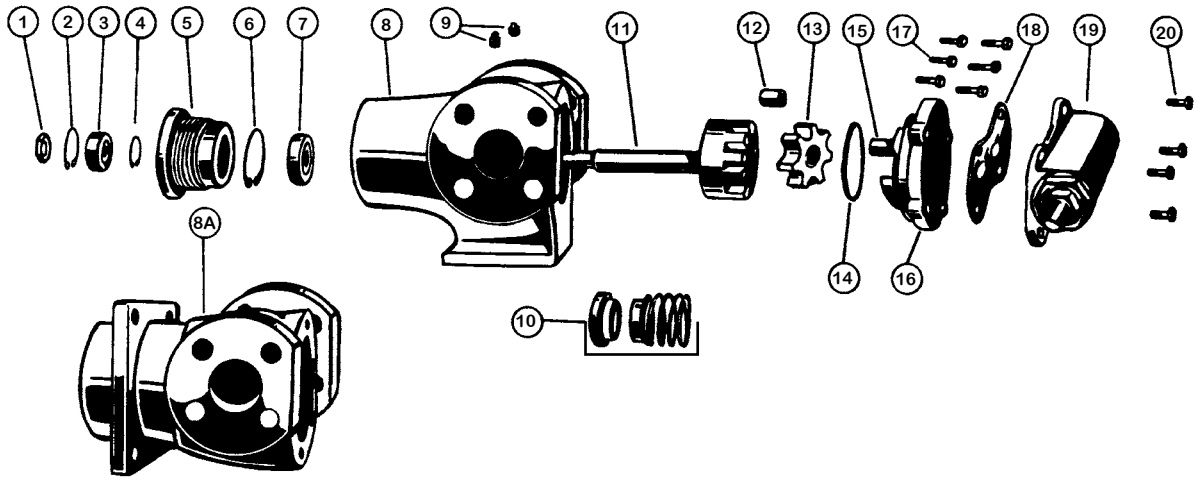

FIGURE 7 - EXPLODED VIEW FOR MODELS GG, HJ AND HL 4193 AND 493

ITEM	NAME OF PART	ITEM	NAME OF PART	ITEM	NAME OF PART
1	Locknut	8	Casing (4193)	14	Head Gasket
2	Snap Ring (Outer)	8A	Casing (493)	15	Idler Pin
3	Ball Bearing (Outer)	9	Pipe Plug	16	Head and Idler Pin Assembly
4	Snap Ring for Shaft	10	Mechanical Seal	17	Capscrew for Head
5	Bearing Housing	11	Rotor and Shaft Assembly	18	Gasket for Relief Valve
6	Snap Ring (Inner)	12	Idler Bushing	19	Relief Valve
7	Ball Bearing (Inner)	13	Idler and Bushing Assembly	20	Capscrew for Valve

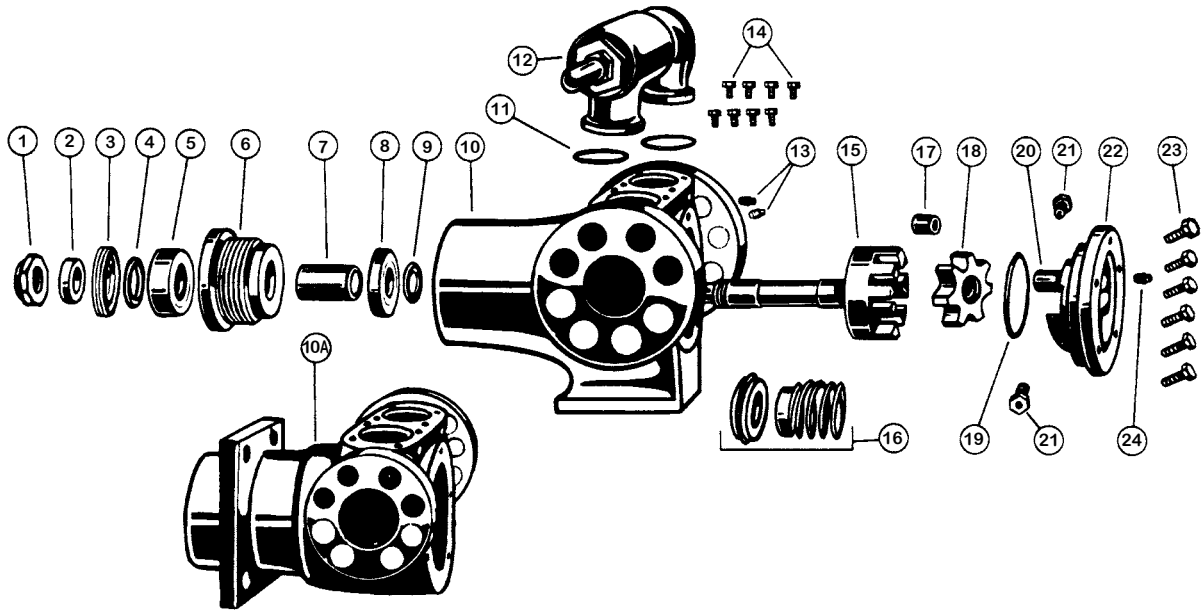

FIGURE 8 - EXPLODED VIEW FOR MODELS AS, AL AND AL 4193 AND 493

ITEM	NAME OF PART	ITEM	NAME OF PART	ITEM	NAME OF PART
1	Locknut	9	Bearing Retainer Washer	16	Mechanical Seal
2	Bearing Spacer Collar	10	Casing (4193)	17	Idler Bushing
3	End Cap for Bearing Housing	10A	Casing (493)	18	Idler and Bushing Assembly
4	Lip Seal for Bearing Housing	11	Gasket for Relief Valve	19	Head Gasket
5	Ball Bearing (Outer)	12	Relief Valve	20	Idler Pin
6	Bearing Housing	13	Pipe Plug	21	Check Valves
7	Bearing Spacer	14	Capscrews for Valve	22	Head and Idler Pin Assembly
8	Ball Bearing (Inner)	15	Rotor and Shaft Assembly	23	Capscrews for Head

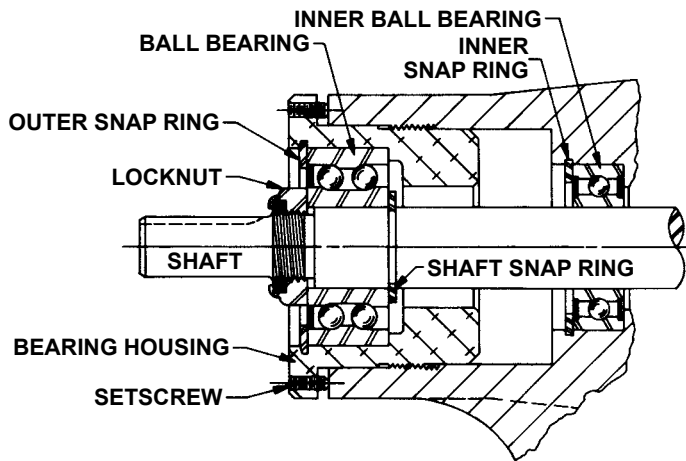

FIGURE 9
THRUST BEARING ASSEMBLY GG, HJ AND HL SIZES

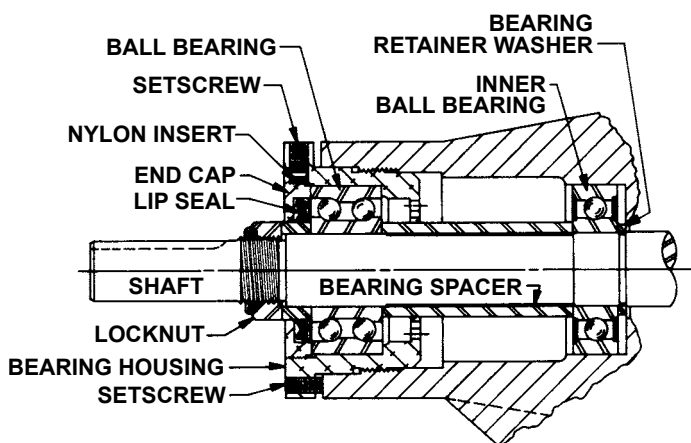

FIGURE 10
THRUST BEARING ASSEMBLY AS, AK AND AL SIZES

11. The rotor and shaft assembly can now be removed by tapping on the end of the shaft with a lead hammer or, if using a regular hammer, use a piece of hardwood between the shaft and hammer. The spring and rotary member of the seal will come out with rotor and shaft.
12. Remove the inner snap ring and single row ball bearing from the casing. **See figure 9.** The AS, AK & AL size pumps do not have this snap ring.
13. Remove the bearing retainer washer from the AS, AK or AL size pumps. **See figure 10.**
14. Remove the seal seat or stationary part of seal from casing.
15. Disassemble thrust bearing assembly. Remove outer snap ring from bearing housing for GG, HJ or HL size pumps and ball bearing can be removed. **See figure 9.**
16. The AS, AK and AL thrust bearing assembly has an end cap and lip seal that can be removed after loosening two set screws in flange of bearing housing. Remove ball bearing. **See figure 10.**

The casing should be examined for wear, particularly in the area between ports. All parts should be checked for wear before pump is put together.

When making major repairs, such as replacing a rotor and shaft; it is advisable to also install a new mechanical seal, head and idler pin, idler and bushing. **See "Installation of Carbon Graphite Bushings" page 7.**

Clean all parts thoroughly and examine for wear or damage. Check lip seals, ball bearings, bushing and idler pin and replace if necessary. Check all other parts for nicks, burrs, excessive wear and replace if necessary.

Wash the bearings in clean solvent. Blow out the bearings with compressed air. Do not allow the bearings to spin; turn them slowly by hand. Spinning the bearings will damage the race and balls. Make sure the bearings are clean, then lubricate with non-detergent SAE 30 weight oil and check for roughness. Roughness can be determined by turning the outer race by hand. Replace the bearings if they have roughness.

Be sure the shaft is free from nicks, burrs and foreign particles that might damage the mechanical seal. Scratches on the shaft in the seal area will provide leakage paths under the mechanical seal. Use a fine emery cloth to remove scratches or sharp edges.

ASSEMBLY

Standard Mechanical Seal (Synthetic Rubber Bellows Type)

READ CAREFULLY BEFORE REASSEMBLING PUMP

The seal used in this pump simple to install and good performance will result if care is taken during installation.

The principle of mechanical seal is contact between the rotary and stationary members. These parts are lapped to a high finish and their sealing effectiveness depends on complete contact.

Prior to installing rotating portion of mechanical seal, prepare rotor and shaft assembly, head and idler assemblies and appropriate gaskets for quick assembly.

Once rotating portion of mechanical seal is installed on rotor and shaft assembly, it is necessary to assemble parts as quickly as possible to ensure the seal does not stick to shaft in wrong axial position. The seal should be expected to stick to the shaft after several minutes setting time.

Never touch sealing faces with anything except clean hands or clean cloth. Minute particles can scratch the seal faces and cause leakage.

1. Coat idler pin with non-detergent SAE 30 weight oil and place idler and bushing in idler pin on head. If replacing a carbon graphite bushing, **refer to installation of Carbon Graphite Bushings, page 7.**
2. Clean rotor, hub and casing seal housing bore. Make sure both are free from dirt and grit. Coat outer diameter of seal seat and inner diameter of seal housing bore with non-detergent SAE 30 weight oil.
3. Start seal seat in seal housing bore. If force is necessary, protect seal face with a clean cardboard disc and gently tap it in place with a hammer using a piece of wood.

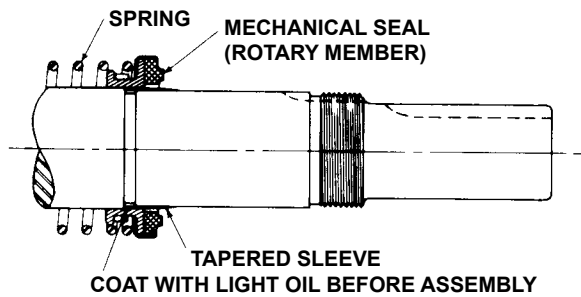

FIGURE 11

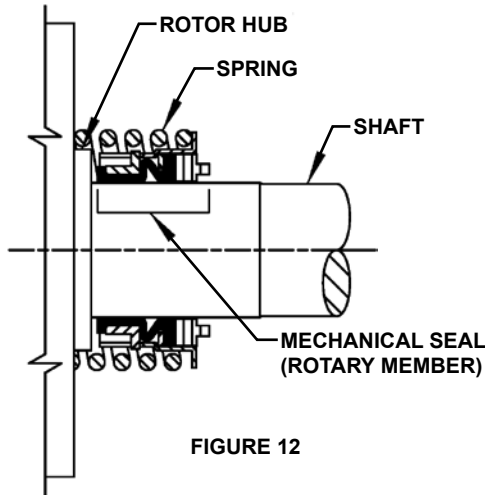

FIGURE 12

4. Place tapered installation sleeve on shaft, **refer to Figure 11**. Sleeve is furnished with GG, AS, AK and AL size replacement mechanical seals. Coat rotor and shaft assembly, tapered installation sleeve and inner diameter of mechanical seal rotary member with a generous amount of non-detergent SAE 30 weight oil. Petrolatum may be used but grease is not recommended.
5. Place seal spring on shaft against rotor hub. **Refer to Figure 12**.
6. Slide rotary member, lapped contact surface facing away from spring, over installation sleeve on shaft until it is against the spring.
7. Do not compress the spring.
8. Coat the rotor and shaft assembly with non-detergent SAE 30 weight oil. Taking care not to damage the seal seat, start end of shaft in bracket bushing and turn from right to left, slowly pushing until the ends of the rotor teeth are just below the face of the casing.
9. Leave the rotor in this position. Withdrawal of rotor and shaft may displace the carbon seal rotating face and result in damage to the seal.
10. Place O-ring gasket on head and install head and idler assembly on pump. Pump head and casing were marked before disassembly to ensure proper reassembly. If not, be sure idler pin, which is offset in pump head, is positioned toward or equal distance between port connections to allow for proper flow of liquid through pump.

11. Tighten head capscrews evenly.
12. If pump was equipped with a relief valve and was removed during disassembly, install with new o-rings or gaskets. Relief valve adjusting screw cap must always point towards suction port. **Refer to Figure 5, page 2**. For relief valve repair or adjustments, **see PRESSURE RELIEF VALVE INSTRUCTIONS, Page 7**.
13. In 2005, the use of single seal bearings were phased out. Pumps now use "Sealed for Life" bearings that have seals on both sides. The new bearings can be installed either side first and do not need to be packed with grease. For older models with single seal bearings, pack the inner ball bearing with multi-purpose grease, NLGI #2
 NOTE: AS, AK and AL size pumps do not have a snap ring, a bearing retainer washer must be assembled over end of shaft before the bearing is assembled. **See figure 10**.
14. Place bearing spacer over shaft and against single row ball bearing in casing (AS, AK and AL size pumps). **See figure 10**.
 Install snap shaft ring in groove in the shaft (GG, HJ and HL size pump). **See figure 8**.
15. Pack lubrication chamber between inner ball bearing and double row ball bearing in the thrust bearing assembly approximately half full with multi-purpose grease, NLGI#2.
See figures 9 and 10.
16. Pack double row ball bearing with multi-purpose grease, NLGI#2 and press into bearing housing with shield side toward coupling end of shaft. **See Figure 9**. (AS, AK and AL size pumps do not use a shielded bearing). Install snap ring to hold bearing in place on GG, HJ and HL size pumps.
 NOTE: On AS, AK and AL size pumps, install lip seal in bearing house end cap. The lip should face towards end of shaft. Put bearing spacer sleeve in lip seal and install in bearing housing and tighten setscrews securely. **See figure 20**.
17. Insert a piece of brass or hard wood through port opening between rotor teeth to keep shaft from turning.
18. Start thrust bearing assembly into casing. Turn by hand until tight. This forces rotor against head. Replace and tighten locknut on shaft.
19. Remove brass piece or hardwood from port opening. Adjust pump end clearance, **refer to page 7**.

DANGER !

Before starting pump, be sure all drive equipment guards are in place.

Failure to properly mount guards may result in serious injury or death.

THRUST BEARING ADJUSTMENT

See Figures 9 and 10.

Loosen two screws in face of thrust bearing assembly.

If shaft cannot be rotated freely, turn thrust bearing assembly counterclockwise until shaft can be turned easily.

To set end clearance:

1. While turning rotor and shaft assembly, rotate thrust bearing assembly clockwise until noticeable drag occurs. This is zero end clearance.
2. Mark position of bearing housing with respect to the casing.
3. Rotate thrust bearing assembly counterclockwise the distance listed below as measured on outside of bearing housing.
4. Tighten two setscrews in face of bearing housing after adjustment is made to secure thrust bearing assembly position.

For viscosities above 2500 SSU, add additional end clearance (0.005" for GG, HJ and HL size pumps and

PUMP SIZE	DISTANCE IN INCHES ON O.D. OF BEARING HOUSING	END CLEARANCE
GG	11/16"	.005
HJ , HL	15/16"	.005
AS , AK , AL	1 1/4"	.008

INSTALLATION OF CARBON GRAPHITE BUSHINGS

When installing carbon graphite bushings, extreme care must be taken to prevent breaking. Carbon graphite is a brittle material and easily cracked. If cracked, the bushing will quickly disintegrate. Using a lubricant and adding a chamfer on the bushing and the mating part will help in installation. The additional precautions listed below must be followed for proper installation:

1. A press must be used for installation.
2. Be certain bushing is started straight.
3. Do not stop pressing operation until bushing is in proper position, starting and stopping may result in a cracked bushing.
4. Check bushing for cracks after installation.

PRESSURE RELIEF VALVE INSTRUCTIONS

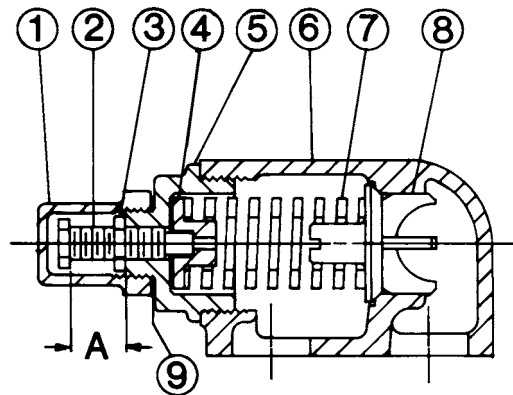

VALVE - GG, HJ and HL SIZES

VALVE - LIST OF PARTS	
1. Cap	6. Valve Body
2. Adjusting Screw	7. Spring
3. Lock Nut	8. Poppet
4. Spring Guide	9. Cap Gasket
5. Bonnet	

FIGURE 13



VALVE - AS, AK and AL SIZES

VALVE - LIST OF PARTS	
1. Cap	6. Valve Body
2. Adjusting Screw	7. Spring
3. Lock Nut	8. Poppet
4. Spring Guide	9. Cap
5. Bonnet	10. Bonnet

FIGURE 14

DISASSEMBLY

DANGER !

Before opening any Viking pump liquid chamber (pumping chamber, reservoir, relief valve adjusting cap fitting, etc.)

Be sure:

- 1. That any pressure in the chamber has been completely vented through the suction or discharge lines or other appropriate openings or connections.**
- 2. That the driving means (motor, turbine, engine, etc.) has been “locked out” or made non-operational so that it cannot be started while work is being done on pump.**
- 3. That you know what liquid the pump has been handling and the precautions necessary to safely handle the liquid. Obtain a material safety data sheet (MSDS) for the liquid to be sure these precautions are understood.**

Failure to follow above listed precautionary measures may result in serious injury or death.

Mark valve and head before disassembly to ensure proper reassembly.

1. Remove valve cap.
2. Measure and record length of extension of adjusting screw. **Refer to “A” on Figures 13 and 14.**
3. Loosen locknut and back out adjusting screw until spring pressure is released.
4. Remove bonnet, spring guide, spring and poppet from valve body. Clean and inspect all parts for wear or damage and replace as necessary.

ASSEMBLY

Reverse procedures outlined under Disassembly. If valve is removed for repairs, be sure to replace in same position. Relief valve adjusting screw cap must always point towards suction side of pump. If pump rotation is reversed, remove relief valve and turn end for end. **Refer to Figures 5, page 2.**

DANGER !

Before starting pump, be sure all drive equipment guards are in place.

Failure to properly mount guards may result in serious injury or death.

PRESSURE ADJUSTMENT

If a new spring is installed or if pressure setting of pressure relief valve is to be changed from that which the factory has set, the following instructions must be carefully followed.

1. Install a pressure gauge in the discharge line for actual adjustment operation.
2. Carefully remove the valve cap which covers the adjusting screw.
Loosen the locknut which locks the adjusting screw so the pressure setting will not change during operation of the pump.
3. Turn the adjusting screw in to increase the pressure and out to decrease the pressure.
4. With the discharge line closed at a point beyond the pressure gauge, gauge will show the maximum pressure the valve will allow while the pump is in operation.

IMPORTANT

In ordering parts for pressure relief valve, always give model number and serial number of pump as it appears on nameplate and name of part wanted. When ordering springs, be sure to give pressure setting desired.

**VIKING
PUMP**

TECHNICAL SERVICE MANUAL

HEAVY-DUTY BRACKET MOUNTED PUMPS

SERIES 4193 AND 493

SIZES GG - AL

SECTION	TSM 154
PAGE	10 OF 10
ISSUE	C

**VIKING
PUMP**

IDEX
IDEX CORPORATION

WARRANTY

Viking warrants all products manufactured by it to be free from defects in workmanship or material for a period of one (1) year from date of startup, provided that in no event shall this warranty extend more than eighteen (18) months from the date of shipment from Viking. If, during said warranty period, any products sold by Viking prove to be defective in workmanship or material under normal use and service, and if such products are returned to Viking's factory at Cedar Falls, Iowa, transportation charges prepaid, and if the products are found by Viking to be defective in workmanship or material, they will be replaced or repaired free of charge, FOB. Cedar Falls, Iowa.

Viking assumes no liability for consequential damages of any kind and the purchaser by acceptance of delivery assumes all liability for the consequences of the use or misuse of Viking products by the purchaser, his employees or others. Viking will assume no field expense for service or parts unless authorized by it in advance.

Equipment and accessories purchased by Viking from outside sources which are incorporated into any Viking product are warranted only to the extent of and by the original manufacturer's warranty or guarantee, if any.

THIS IS VIKING'S SOLE WARRANTY AND IS IN LIEU OF ALL OTHER WARRANTIES, EXPRESSED OR IMPLIED, WHICH ARE HEREBY EXCLUDED, INCLUDING IN PARTICULAR ALL WARRANTIES OF MERCHANTABILITY OR FITNESS FOR A PARTICULAR PURPOSE. No officer or employee of IDEX Corporation or Viking Pump, Inc. is authorized to alter this warranty.