



TECHNICAL SERVICE MANUAL

HEAVY-DUTY PUMPS
 SERIES 4195 AND 495
 SIZES GG - AL

SECTION	TSM 144
PAGE	1 OF 10
ISSUE	D

CONTENTS

Introduction	1
Safety Information.	2
Special Information	3
Special Mechanical Seals.	3
Maintenance	3
Disassembly	4
Assembly	7
Thrust Bearing Adjustment	8
Installation of Carbon Graphite Bushings.	8
Pressure Relief Valve Instructions	9

INTRODUCTION

The illustrations used in this manual are for identification purposes only and cannot be used for ordering parts. Obtain a parts list from the factory or a Viking® representative. Always give complete name of part, part number and material with model number and serial number of pump when ordering repair parts. The unmounted pump or pump unit model number and serial number are on the nameplate.

In the Viking model number system, basic size letters are combined with series number (4195 and 495) are used to indicate either an unmounted pump or mounted pump unit.

UNMOUNTED PUMP	UNITS
Foot Mounted	Units are designated by the unmounted pump model numbers followed by a letter(s) indicating drive style. D = Direct Drive
GG4195	
HJ4195	
HL4195	
AS4195	
AK4195	
AL4195	
Flange Mounted	M = Horizontal Direct Drive
GG495	
HJ495	
HL495	
AS495	
AK495	
AL495	

This manual deals only with Series 4195 and 495 Heavy Duty Pumps. Refer to Figures 1 through 14 for general configuration and nomenclature used in this manual. Pump specifications and recommendations are listed in Catalog Section 144, Series 4195 and 495 Heavy Duty Pumps.



FIGURE 1
GG, HJ and HL4195 SERIES
 Foot Type Unmounted Pump with Tapped Ports



FIGURE 2
AS, AK and AL4195 SERIES
 Foot Type Unmounted Pump with Tapped Ports



FIGURE 3
GG, HJ and HL495 SERIES
 Unmounted Pump with Tapped Ports



FIGURE 4
AS, AK and AL495 SERIES
 Unmounted Pump with Tapped Ports



SAFETY INFORMATION AND INSTRUCTIONS

IMPROPER INSTALLATION, OPERATION OR MAINTENANCE OF PUMP MAY CAUSE SERIOUS INJURY OR DEATH AND/OR RESULT IN DAMAGE TO PUMP AND/OR OTHER EQUIPMENT. VIKING'S WARRANTY DOES NOT COVER FAILURE DUE TO IMPROPER INSTALLATION, OPERATION OR MAINTENANCE.

THIS INFORMATION MUST BE FULLY READ BEFORE BEGINNING INSTALLATION, OPERATION OR MAINTENANCE OF PUMP AND MUST BE KEPT WITH PUMP. PUMP MUST BE INSTALLED, OPERATED AND MAINTAINED ONLY BY SUITABLY TRAINED AND QUALIFIED PERSONS.

THE FOLLOWING SAFETY INSTRUCTIONS MUST BE FOLLOWED AND ADHERED TO AT ALL TIMES.

Symbol Legend :



Danger - Failure to follow the indicated instruction may result in serious injury or death.

WARNING

Warning - In addition to possible serious injury or death, failure to follow the indicated instruction may cause damage to pump and/or other equipment.



BEFORE opening any liquid chamber (pumping chamber, reservoir, relief valve adjusting cap fitting, etc.) be sure that :

- Any pressure in the chamber has been completely vented through the suction or discharge lines or other appropriate openings or connections.
- The pump drive system means (motor, turbine, engine, etc.) has been "locked out" or otherwise been made non-operational so that it cannot be started while work is being done on the pump.
- You know what material the pump has been handling, have obtained a material safety data sheet (MSDS) for the material, and understand and follow all precautions appropriate for the safe handling of the material.

WARNING

INSTALL pressure gauges/sensors next to the pump suction and discharge connections to monitor pressures.



WARNING

USE extreme caution when lifting the pump. Suitable lifting devices should be used when appropriate. Lifting eyes installed on the pump must be used **only** to lift the pump, **not** the pump with drive and/or base plate. If the pump is mounted on a base plate, the base plate must be used for all lifting purposes. If slings are used for lifting, they must be safely and securely attached. For weight of the pump alone (which does not include the drive and/or base plate) refer to the Viking Pump product catalog.



BEFORE operating the pump, be sure all drive guards are in place.



DO NOT attempt to dismantle a pressure relief valve that has not had the spring pressure relieved or is mounted on a pump that is operating.



DO NOT operate pump if the suction or discharge piping is not connected.



AVOID contact with hot areas of the pump and/or drive. Certain operating conditions, temperature control devices (jackets, heat-tracing, etc.), improper installation, improper operation, and improper maintenance can all cause high temperatures on the pump and/or drive.



DO NOT place fingers into the pumping chamber or its connection ports or into any part of the drive train if there is **any possibility** of the pump shafts being rotated.



WARNING

THE PUMP must be provided with pressure protection. This may be provided through a relief valve mounted directly on the pump, an in-line pressure relief valve, a torque limiting device, or a rupture disk. If pump rotation may be reversed during operation, pressure protection must be provided on **both** sides of pump. Relief valve adjusting screw caps must always point towards suction side of the pump. If pump rotation is reversed, position of the relief valve must be changed. Pressure relief valves cannot be used to control pump flow or regulate discharge pressure. For additional information, refer to Viking Pump's Technical Service Manual TSM 000 and Engineering Service Bulletin ESB-31.

WARNING

DO NOT exceed the pumps rated pressure, speed, and temperature, or change the system/duty parameters from those the pump was originally supplied, without confirming its suitability for the new service.



WARNING

BEFORE operating the pump, be sure that:

- It is clean and free from debris
- all valves in the suction and discharge pipelines are fully opened.
- All piping connected to the pump is fully supported and correctly aligned with the pump.
- Pump rotation is correct for the desired direction of flow.



WARNING

THE PUMP must be installed in a matter that allows safe access for routine maintenance and for inspection during operation to check for leakage and monitor pump operation.

SPECIAL INFORMATION

DANGER !

Before opening any Viking pump liquid chamber (pumping chamber, reservoir, relief valve adjusting cap fitting, etc.) Be sure:

1. That any pressure in the chamber has been completely vented through the suction or discharge lines or other appropriate openings or connections.
2. That the driving means (motor, turbine, engine, etc.) has been "locked out" or made non-operational so that it cannot be started while work is being done on pump.
3. That you know what liquid the pump has been handling and the precautions necessary to safely handle the liquid. Obtain a material safety data sheet (MSDS) for the liquid to be sure these precautions are understood.

Failure to follow above listed precautionary measures may result in serious injury or death.

ROTATION: Viking pumps operate equally well in a clockwise or counterclockwise rotation. Shaft rotation determines which port is suction and which is discharge. Suction Port is where pumping elements (gear teeth) come out of mesh.

PRESSURE RELIEF VALVES:

1. Viking pumps are positive displacement pumps and must be provided with some sort of pressure protection. This may be a relief valve mounted directly on the pump, an inline pressure relief valve, a torque limiting device or a rupture disk.
2. There are relief valve options available on those pump models designed to accept a relief valve. Options may include a return to tank relief valve. Pumps equipped with a jacketed head plate are generally not available with a relief valve.
3. If pump rotation is reversed during operation, pressure protection must be provided on both sides of the pump.
4. The relief valve adjusting screw cap must always point towards the suction side of the pump. If pump rotation is reversed, remove the pressure relief valve and turn end for end. Refer to **Figure 5**.
5. Pressure relief valves should not be used to control flow or regulate discharge pressure.

For additional information on pressure relief valves, refer to **Technical Service Manual TSM 000 and Engineering Service Bulletin ESB-31**.

SPECIAL MECHANICAL SEALS:

This bulletin illustrates the mechanical seal which is standard in the catalog pump. A Seal Installation Drawing will be furnished with a pump fitted with a non-standard mechanical seal. Consult this Seal Installation Drawing before disassembling pump.

Modifications are required to install PTFE mechanical seals in these pumps. Contact the factory for specific information.

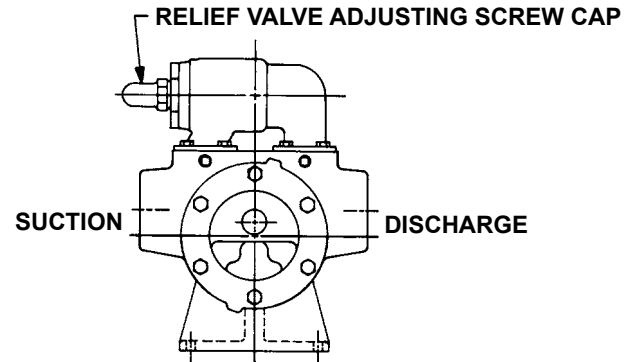

FIGURE 5

MAINTENANCE

Series 4195 and 495 pumps are designed for long, trouble-free service life under a wide variety of application conditions with a minimum of maintenance. The points listed below will help provide long service life.

CLEANING PUMP: Keep the pump as clean as possible. This will facilitate inspection, adjustment and repair work and help prevent overlooking a dirt covered grease fitting.

STORAGE: If the pump is to be stored, or not used for six months or more, the pump must be drained and a light coat of non-detergent SAE 30 weight oil must be applied to all internal pump parts. Lubricate the fittings and apply grease to the pump shaft extension. Viking suggests rotating pump shaft by hand one complete revolution every 30 days to circulate the oil.

SUGGESTED REPAIR TOOLS: The following tools must be available to properly repair Series 4195 and 495 pumps. These tools are in addition to standard mechanics' tools such as open end wrenches, pliers, screw drivers, etc. Most of the items can be obtained from an industrial supply house.

1. Soft Headed hammer
2. Allen wrenches (set screws & special mechanical seals)
3. Snap Ring Pliers
INTERNAL – Viking Part No. 2-810-047-999
GG-HJ-HL 4195-495
EXTERNAL – Viking Part No. 2-810-029-375
GG-HJ-HL 4195-495
4. Mechanical Seal Installation Sleeve
2-751-001-730 for 0.75 inch seal; GG 4195-495
2-751-004-730 for 1.25 inch seal; AS-AL 4195-495
5. Bearing Locknut Spanner Wrench – 2-810-043-375
6. Spanner Wrench, adjustable pin type for use on bearing housing end cap. – 2-810-008-375
7. Brass bar
8. Arbor press
9. Standard 5/16" 12 point socket

DISASSEMBLY

DANGER !

Before opening any Viking pump liquid chamber (pumping chamber, reservoir, relief valve adjusting cap fitting, etc.) Be sure:

1. That any pressure in the chamber has been completely vented through the suction or discharge lines or other appropriate openings or connections.
2. That the driving means (motor, turbine, engine, etc.) has been "locked out" or made non-operational so that it cannot be started while work is being done on pump.
3. That you know what liquid the pump has been handling and the precautions necessary to safely handle the liquid. Obtain a material safety data sheet (MSDS) for the liquid to be sure these precautions are understood.

Failure to follow above listed precautionary measures may result in serious injury or death.

1. Refer to **Figures 7 & 8**, page 5 for model to be disassembled and name of parts. Models 4195 & 495 are disassembled and assembled in the same manner. The difference between these models is the casings.
2. Mark the head and casing before disassembly to insure proper reassembly.
3. **NOTE:** The four valve capscrews, valve and gasket must be removed from the GG4195-495 model before the six head capscrews are removed.
Remove the head capscrews.
4. Tilt the top of the head back when removing to prevent the idler from falling off the idler pin.
5. Remove the idler and bushing assembly. If the idler bushing needs replacing, see "**Installation of Carbon Graphite Bushings**," page 8.
6. Insert a brass bar or piece of hardwood in the port opening and between the rotor teeth to keep the shaft from turning. Turn the locknut counterclockwise and remove locknut. See **Figure 9 or 10**, page 6.
7. Loosen the two setscrews in the face of the bearing housing and turn the thrust bearing assembly counterclockwise and remove from casing. See **Figure 9 or 10**, page 6.
8. **GG, HJ, HL:** Remove the snap ring from the shaft. See **Figure 9**, page 6.
AS, AK, AL: Remove the bearing spacer from the shaft. See **Figure 10**, page 6.
9. Remove the brass bar or piece of hardwood from the port opening.

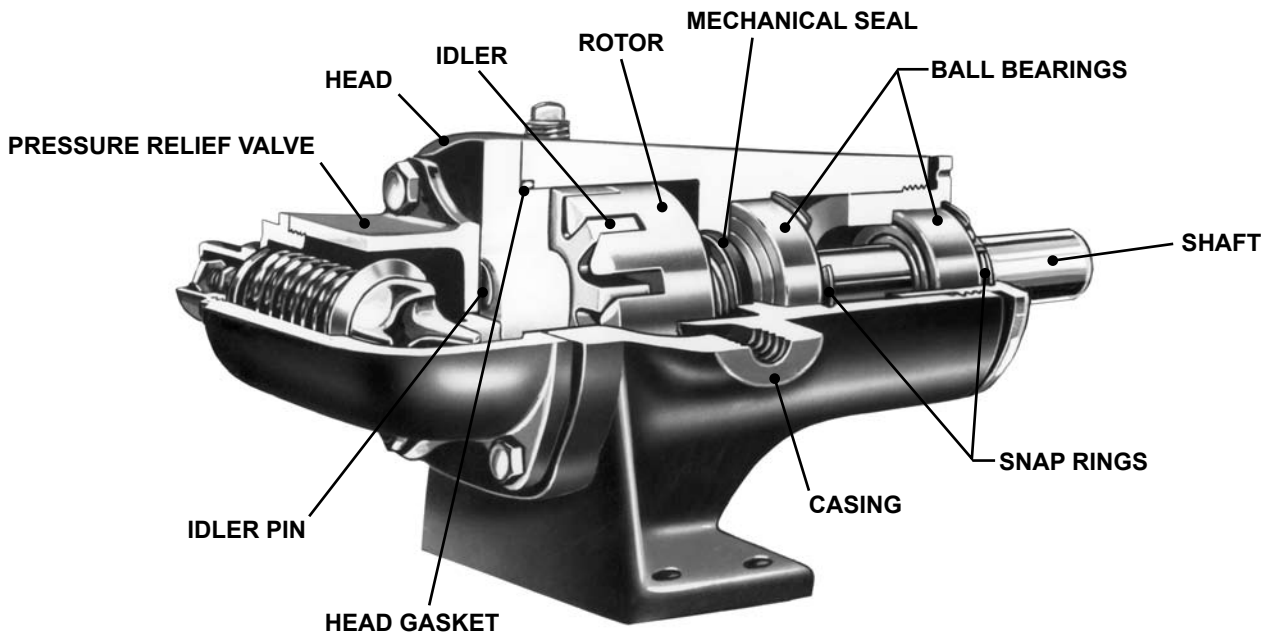

FIGURE 6
CUTAWAY FOR MODELS GG, HJ AND HL4195

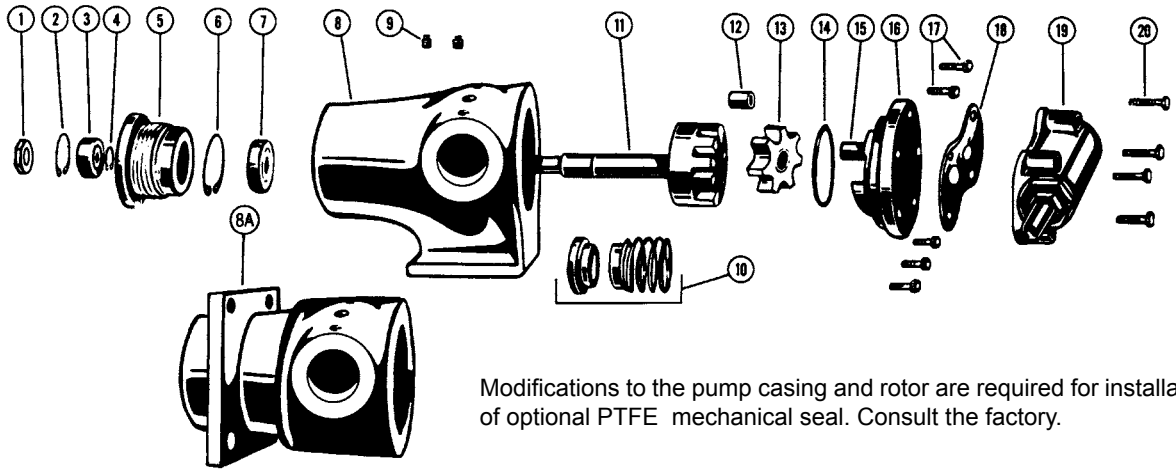

FIGURE 7 - EXPLODED VIEW FOR MODELS GG, HJ AND HL 4195 AND 495

ITEM	NAME OF PART	ITEM	NAME OF PART	ITEM	NAME OF PART
1	Locknut	8	Casing (4195)	14	Head O-Ring
2	Snap Ring (Outer)	8A	Casing (495)	15	Idler Pin
3	Ball Bearing (Outer)	9	Pipe Plug	16	Head and Idler Pin Assembly
4	Snap Ring for Shaft *	10	Mechanical Seal	17	Capscrew for Head
5	Bearing Housing	11	Rotor and Shaft Assembly	18	Gasket for Relief Valve
6	Snap Ring (Inner)	12	Idler Bushing	19	Relief Valve
7	Ball Bearing (Inner)	13	Idler and Bushing Assembly	20	Capscrew for Valve

* Not used on "GG" size pumps.

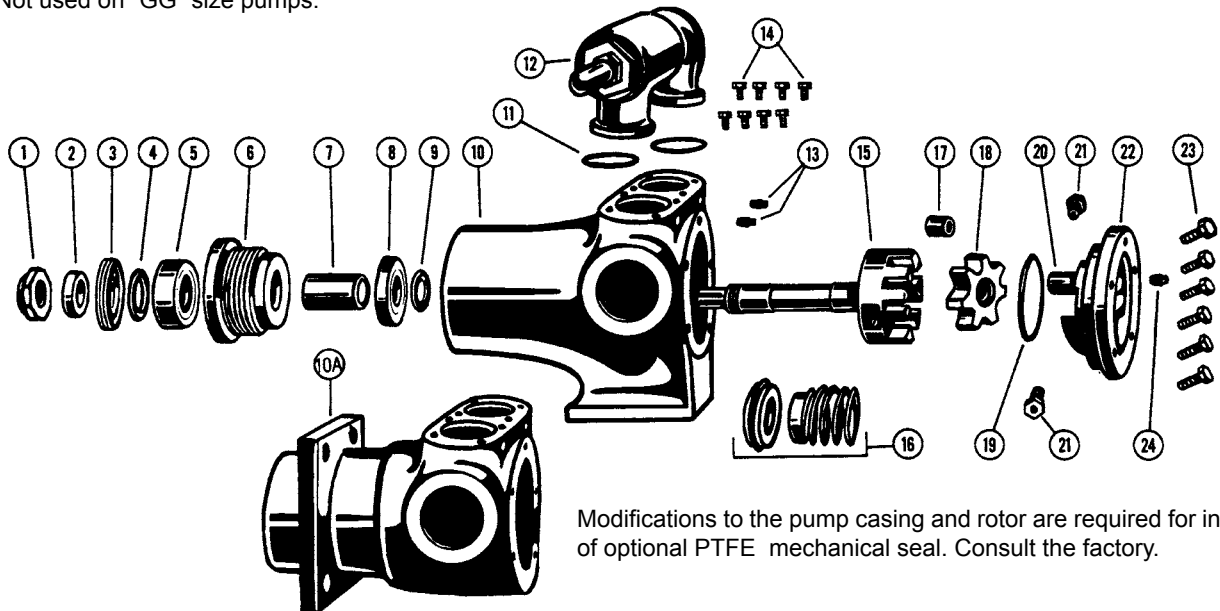

FIGURE 8 - EXPLODED VIEW FOR MODELS AS, AK AND AL 4195 AND 495

ITEM	NAME OF PART	ITEM	NAME OF PART	ITEM	NAME OF PART
1	Locknut	9	Bearing Retainer Washer	16	Mechanical Seal
2	Bearing Spacer Collar	10	Casing (4195)	17	Idler Bushing
3	End Cap for Bearing Housing	10A	Casing (495)	18	Idler and Bushing Assembly
4	Lip Seal for Bearing Housing	11	O-Rings for Relief Valve	19	Head O-Ring
5	Ball Bearing (Outer)	12	Relief Valve	20	Idler Pin
6	Bearing Housing	13	Pipe Plug	21	Check Valve
7	Bearing Spacer	14	Capscrew for Valve	22	Head and Idler Pin Assembly
8	Ball Bearing (Inner)	15	Rotor and Shaft Assembly	23	Capscrew for Head

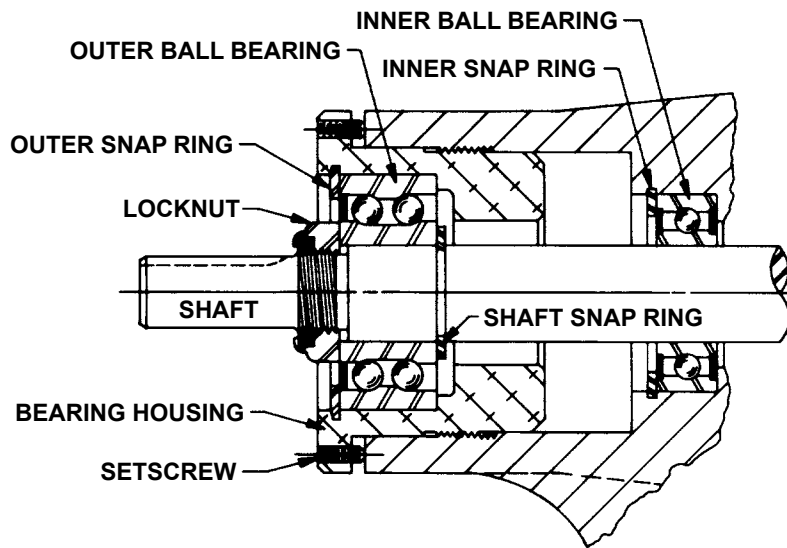

FIGURE 9 - THRUST BEARING ASSEMBLY GG, HJ AND HL SIZES

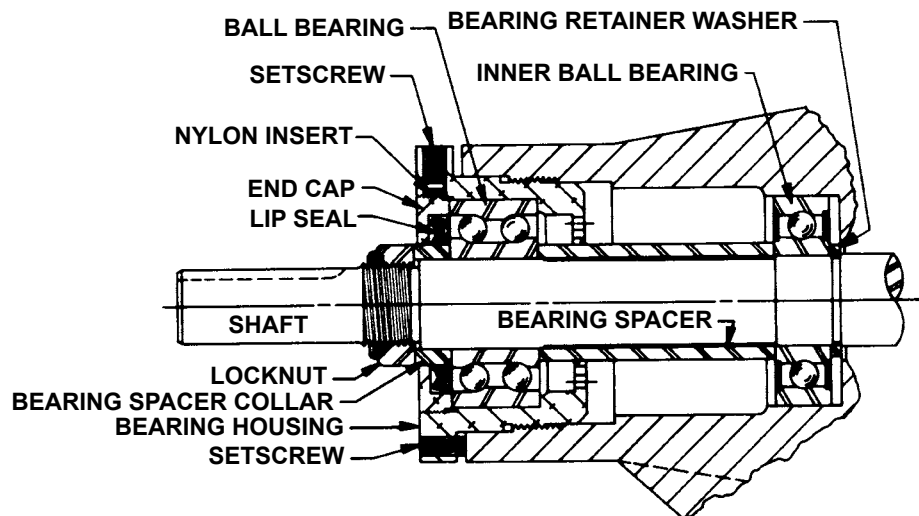

FIGURE 10 - THRUST BEARING ASSEMBLY AS, AK AND AL SIZES

10. The rotor and shaft can now be removed by tapping on the end of the shaft with a lead hammer or, if using a regular hammer, use a piece of hardwood between the shaft and hammer. The rotary member of the seal will come out with the rotor and shaft.
11. **AS, AK, AL:** Remove the bearing retainer washer. The washer may have stayed with the rotor and shaft when removed or is against the ball bearing. See **Figure 10**.
12. Remove the mechanical seal rotary member and spring from the rotor and shaft assembly.
13. **GG, HJ, HL:** Remove the inner snap ring and single row ball bearing from the casing.
AS, AK, AL: Remove the single row ball bearing from the casing.
14. Remove the seal seat or stationary part of the seal from the casing.

15. Disassemble the thrust bearing assembly.

GG, HJ, HL: Remove the outer snap ring from the bearing housing and remove the ball bearing. See **Figure 9**.

AS, AK, AL: Loosen the two setscrews in the flange outside diameter. Rotate the end cap and lip seal counterclockwise and remove. Remove the ball bearing. See **Figure 10**.

The casing should be examined for wear, particularly in the area between the ports. All parts should be checked for wear before the pump is put together.

When making major repairs, such as replacing a rotor and shaft; it is advisable to also install a new mechanical seal, head and idler pin, idler and bushing. See "**Installation of Carbon Graphite Bushings**," page 8.

Clean all parts thoroughly and examine for wear or damage. Check the lip seals, ball bearings, bushing and idler pin and replace if necessary. Check all other parts for nicks, burrs, excessive wear and replace if necessary.

Wash the bearings in clean solvent. Blow out the bearings with compressed air. Do not allow the bearings to spin; turn them slowly by hand. Spinning the bearings will damage the race and balls. Make sure the bearings are clean, then lubricate with non-detergent SAE 30 weight oil and check for roughness. Roughness can be determined by turning the outer race by hand. Replace the bearings if they have roughness.

Be sure the shaft is free from nicks, burrs and foreign particles that might damage the mechanical seal. Scratches on the shaft in seal area will provide leakage paths under the mechanical seal. Use a fine emery cloth to remove scratches or sharp edges.

ASSEMBLY

Standard Mechanical Seal (Synthetic Rubber Bellows Type)

READ CAREFULLY BEFORE REASSEMBLING PUMP

The seal used in this pump is simple to install and good performance will result if care is taken during installation.

The principle of a mechanical seal is contact between the rotary and stationary members. These parts are lapped to a high finish and their sealing effectiveness depends on complete contact.

Prior to installing the rotary portion of the mechanical seal, prepare and organize the rotor shaft, head and idler assemblies and appropriate gaskets for quick assembly.

Once the rotary portion of the mechanical seal is installed on the rotor shaft, it is necessary to assemble the parts as quickly as possible to insure the seal does not stick to the shaft in the wrong axial position. The seal will stick to the shaft after several minutes setting time.

Never touch the sealing faces with anything except clean hands or clean cloth. Minute particles can scratch the seal faces and cause leakage.

1. Coat the idler pin with non-detergent SAE 30 weight oil and place idler and bushing on idler pin in the head. If replacing a carbon graphite bushing, refer to "Installation of Carbon Graphite Bushings," page 8.
2. Clean the rotor hub and casing seal housing bore. Make sure both are free from dirt and grit. Coat the outer diameter of seal seat and inner diameter of seal housing bore with non-detergent SAE 30 weight oil.
3. Start the seal seat in the seal housing bore. If force is necessary protect the seal face with a clean cardboard disc and gently tap it in place with a piece of wood. Be sure the seal seat is completely seated in the bore.
4. Place a tapered installation sleeve on the shaft, refer to **Figure 11**. The sleeve is furnished with GG, AS, AK and AL replacement mechanical seals. Coat the rotor shaft, tapered installation sleeve and inner diameter of the mechanical seal rotary member with a generous amount of non-detergent SAE 30 weight oil. Petrolatum may be used but grease is not recommended.
5. Place the seal spring on the shaft against the rotor hub. Refer to **Figure 12**.

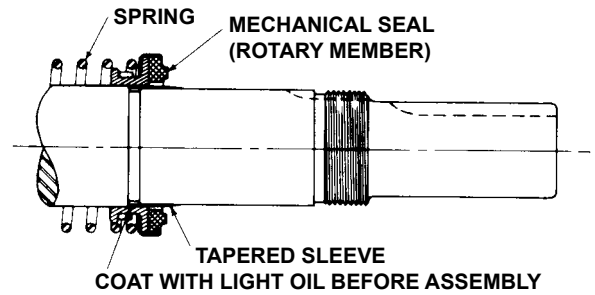

FIGURE 11

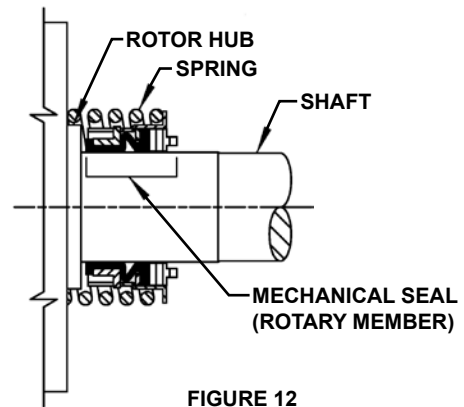

FIGURE 12

6. Slide the rotary member, lapped contact surface facing away from the spring, over installation sleeve on shaft until just contacting the spring. Do not compress the spring. Remove the installation sleeve.
7. Coat the rotor shaft with non-detergent SAE 30 weight oil. Install the rotor and shaft into the casing, slowly pushing until the ends of the rotor teeth are just below the face of the casing. Take care not to damage the seal seat.
8. Leave the rotor in this position. Withdrawal of the rotor and shaft may displace the carbon seal rotating face and result in damage to the seal.
9. Place the O-ring or gasket on the head and install the head and idler assembly on pump. The pump head and casing were marked before disassembly to insure proper reassembly. If not, be sure the idler pin, which is offset in the pump head, is positioned up and equal distance between port connections to allow for proper flow of liquid through the pump.
10. Tighten the head capscrews evenly.
11. If the pump was equipped with a relief valve and was removed during disassembly, install on the head with new O-Rings or gaskets. The relief valve adjusting screw cap must always point towards the suction port. Refer to **Figure 5**, page 3. For relief valve repair or adjustments, see "Pressure Relief Valve Instructions," Page 9.
12. In 2005, the use of single seal bearings were phased out. Pumps now use "Sealed for Life" bearings that have seals on both sides. The new bearings can be installed either side first and do not need to be packed with grease. For older models with single seal bearings, pack the inner ball bearing with multi-purpose grease, NLGI #2.

GG, HJ, HL: Drive the bearing into the bore. Tap the inner race with a brass bar and lead hammer to position bearing. Install the inner snap ring.

AS, AK, AL: Install the bearing retainer washer over the shaft before installing the ball bearing. Install the ball bearing in the casing with sealed side towards head end of the pump. Drive the bearing into the bore. Tap the inner race with a brass bar and lead hammer to position the bearing.

13. GG, HJ, HL: Install the shaft snap ring in groove in the shaft. See **Figure 9**, page 6.

AS, AK, AL: Install the bearing spacer over the shaft and against the single row ball bearing. See **Figure 10**, page 6.

14. Pack the lubrication chamber between the inner ball bearing and double row ball bearing in the thrust bearing assembly approximately one-half full of multi-purpose grease, NLGI #2. The thrust bearing assembly will take the remaining space. See **Figure 9 and 10**, page 6.

15. Pack the double row ball bearing with multi-purpose grease, NLGI #2.

GG, HJ, HL: Install the ball bearing into the bearing housing with shield side toward the coupling end of the shaft. See **Figure 9**, page 6. Install the snap ring into bearing housing to retain ball bearing. This snap ring has a tapered edge to fit tapered groove in bearing housing. The tapered edge is located away from the ball bearing.

AS, AK, AL: Install the ball bearing into the bearing housing. Install the lip seal in the bearing housing end cap. The lip should face towards the end of the shaft. Put the bearing spacer collar in the lip seal and install in the bearing housing and tighten the set screws securely. See **Figure 10**, page 6.

16. Insert a brass bar or piece of hardwood through the port opening between the rotor teeth to keep the shaft from turning.

17. Start the thrust bearing assembly into casing. Turn by hand until tight. This forces the rotor against the head. Replace and tighten the locknut or shaft.

18. Remove the brass bar or hardwood from port opening.

19. Adjust pump end clearance, refer to **“Thrust Bearing Adjustment”**.

THRUST BEARING ADJUSTMENT

See **Figures 9 and 10**.

Loosen the two screws in the face of the thrust bearing assembly.

If the shaft cannot be rotated freely, turn the thrust bearing assembly counterclockwise until the shaft can be turned easily.

To set end clearance:

1. While turning the rotor shaft, rotate the thrust bearing assembly clockwise until a noticeable drag occurs. This is zero end clearance.
2. Mark the position of the bearing housing with respect to the casing.
3. Rotate the thrust bearing assembly counterclockwise the distance listed below as measured on outside of bearing housing.
4. After the adjustment is made, tighten the two setscrews in the face of the bearing housing assembly to secure the position.

For viscosities above 2500 SSU, add additional end clearance (0.004" for GG, HJ and HL size pumps and 0.005" for AS, AK and AL size pumps).

PUMP SIZE	DISTANCE IN INCHES ON O.D. OF BEARING HOUSING	STANDARD END CLEARANCE
GG	0.44" (7/16")	.003
HJ , HL	0.56" (9/16")	.003
AS , AK , AL	0.5" (1/2")	.003

INSTALLATION OF CARBON GRAPHITE BUSHINGS

When installing the carbon graphite bushings, extreme care must be taken to prevent breaking. Carbon graphite is a brittle material and is easily cracked. If cracked, the bushing will quickly disintegrate. Using a lubricant and adding a chamfer on the bushing and the mating part will help in installation. The additional precautions listed below must be followed for proper installation:

1. A press must be used for installation.
2. Be certain the bushing is started straight.
3. Do not stop pressing the operation until the bushing is in the proper position, as starting and stopping may result in a cracked bushing.
4. Check the bushing for cracks after installation.

DANGER !

Before starting pump, be sure all drive equipment guards are in place.

Failure to properly mount guards may result in serious injury or death.

PRESSURE RELIEF VALVE INSTRUCTIONS

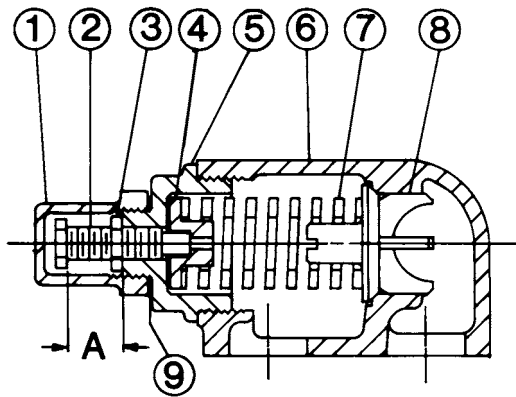

FIGURE 13
VALVE - GG, HJ and HL SIZES

VALVE - LIST OF PARTS	
1. Valve Cap	6. Valve Body
2. Adjusting Screw	7. Valve Spring
3. Lock Nut	8. Poppet
4. Spring Guide	9. Cap Gasket
5. Bonnet	

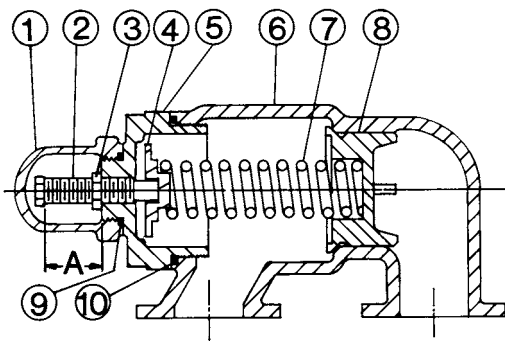

FIGURE 14
VALVE - AS, AK and AL SIZES

VALVE - LIST OF PARTS	
1. Valve Cap	6. Valve Body
2. Adjusting Screw	7. Valve Spring
3. Lock Nut	8. Poppet
4. Spring Guide	9. Cap Gasket
5. Bonnet	10. Bonnet O-Ring

DISASSEMBLY

DANGER !

Before opening any Viking pump liquid chamber (pumping chamber, reservoir, relief valve adjusting cap fitting, etc.) Be sure:

1. That any pressure in the chamber has been completely vented through the suction or discharge lines or other appropriate openings or connections.
2. That the driving means (motor, turbine, engine, etc.) has been "locked out" or made non-operational so that it cannot be started while work is being done on pump.
3. That you know what liquid the pump has been handling and the precautions necessary to safely handle the liquid. Obtain a material safety data sheet (MSDS) for the liquid to be sure these precautions are understood.

Failure to follow above listed precautionary measures may result in serious injury or death.

Mark the valve and head before disassembly to ensure proper reassembly.

1. Remove the valve cap.
2. Measure and record the length of extension of the adjusting screw. Refer to "A" on Figures 13 and 14.
3. Loosen the locknut and back out the adjusting screw until spring pressure is released.
4. Remove the bonnet, spring guide, spring and poppet from the valve body. Clean and inspect all parts for wear or damage and replace as necessary.

ASSEMBLY

Reverse the procedures outlined under "Disassembly." If the valve is removed for repairs, be sure to replace in the same position. The relief valve adjusting screw cap must always point towards suction side of the pump. If the pump rotation is reversed, remove the relief valve and turn end for end. Refer to Figure 5, page 3.

**VIKING
PUMP**

TECHNICAL SERVICE MANUAL

HEAVY-DUTY PUMPS
SERIES 4195 AND 495
SIZES GG - AL

SECTION	TSM 144
PAGE	10 OF 10
ISSUE	D

DANGER !

Before starting pump, be sure all drive equipment guards are in place.

Failure to properly mount guards may result in serious injury or death.

PRESSURE ADJUSTMENT

If a new spring is installed or if the pressure setting of the pressure relief valve is to be changed from that which the factory has set, the following instructions must be carefully followed.

1. Carefully remove the valve cap which covers the adjusting screw.
Loosen the locknut which locks the adjusting screw so the pressure setting will not change during operation of the pump.
2. Install a pressure gauge in the discharge line for actual adjustment operation.
3. Turn the adjusting screw in to increase the pressure and out to decrease the pressure.
4. With discharge line closed at a point beyond pressure gauge, the gauge will show the maximum pressure the valve will allow while the pump is in operation.

IMPORTANT

When ordering parts for the pressure relief valve, always give the model number and serial number of the pump as it appears on the nameplate and the name of the part wanted. When ordering springs, be sure to give the pressure setting desired.

**VIKING
PUMP**

IDEX
IDEX CORPORATION

WARRANTY

Viking warrants all products manufactured by it to be free from defects in workmanship or material for a period of one (1) year from date of startup, provided that in no event shall this warranty extend more than eighteen (18) months from the date of shipment from Viking. If, during said warranty period, any products sold by Viking prove to be defective in workmanship or material under normal use and service, and if such products are returned to Viking's factory at Cedar Falls, Iowa, transportation charges prepaid, and if the products are found by Viking to be defective in workmanship or material, they will be replaced or repaired free of charge, FOB. Cedar Falls, Iowa.

Viking assumes no liability for consequential damages of any kind and the purchaser by acceptance of delivery assumes all liability for the consequences of the use or misuse of Viking products by the purchaser, his employees or others. Viking will assume no field expense for service or parts unless authorized by it in advance.

Equipment and accessories purchased by Viking from outside sources which are incorporated into any Viking product are warranted only to the extent of and by the original manufacturer's warranty or guarantee, if any.

THIS IS VIKING'S SOLE WARRANTY AND IS IN LIEU OF ALL OTHER WARRANTIES, EXPRESSED OR IMPLIED, WHICH ARE HEREBY EXCLUDED, INCLUDING IN PARTICULAR ALL WARRANTIES OF MERCHANTABILITY OR FITNESS FOR A PARTICULAR PURPOSE. No officer or employee of IDEX Corporation or Viking Pump, Inc. is authorized to alter this warranty.