



BY JOHNSON CONTROLS

Form 090-020 CS (AUGUST 2009)

**COMMUNICATIONS SETUP**

File: SERVICE MANUAL - SECTION 90  
Replaces: S90-020 CS/FEB 2009  
Dist: 3, 3a, 3b, 3c

COMMUNICATIONS SETUP

FRICK® QUANTUM™ LX  
COMPRESSOR  
CONTROL PANEL  
VERSION 6.6x

Please check [www.johnsoncontrols.com](http://www.johnsoncontrols.com) for the latest version of this publication.

## TABLE OF CONTENTS

<b>INTRODUCTION TO THE QUANTUM™ LX.....</b>	<b>5</b>
Quantum™ Description .....	5
How To Use This Manual.....	5
<b>ETHERNET AND NETWORKING .....</b>	<b>6</b>
Description.....	6
Cabling.....	6
RJ-45 Connectors .....	7
The Hub .....	7
The Switch.....	7
Ethernet Setup .....	9
IP Data.....	9
Naming Data.....	10
E-Mail Data.....	10
Protocols .....	10
<b>SERIAL COMMUNICATIONS .....</b>	<b>11</b>
General Description.....	11
Com-1 And Com-2 Description.....	11
Com-3 Description.....	11
RS-232 Description .....	12
RS-422/RS-485 Description .....	12
Serial Communications Setup.....	13
Using The Map File.....	14
Serial Communication Setup Table.....	16
<b>SERIAL PROTOCOL.....</b>	<b>17</b>
Description.....	17
Quantum™ LX Communications Protocol List.....	17
Checklist For Setting Up Communication.....	17
Frick® Protocol.....	18
Description .....	18
Frick® # Protocol Specifications.....	18
Quantum™ \$ Protocol Specifications.....	25
Data Packet .....	25
Quantum™ LX Allen-Bradley Communication .....	33
Overview Of Half And Full Duplex Theory.....	33
SLC-500 - Suggested Setup.....	34
Channel Configuration .....	34
Read Message Setup Example .....	34
Write Message Setup Example .....	34
Allen-Bradley Programming Overview .....	35
Channel Configuration .....	35
General Configuration.....	35
System Configuration.....	36
Message Sequence Logic.....	36
Message Read Logic .....	37
Message Read Setup Screen .....	38
Message Write Logic .....	39
Message Write Setup Screen .....	41
Allen-Bradley Data Access.....	41
Ethernet/IP .....	41

<b>MODBUS® Protocol</b> .....	<b>42</b>
General Description.....	42
Modbus® TCP/IP (Ethernet).....	42
Modbus® ASCII (Serial Communications) .....	42
Modbus® RTU (Serial Communications) .....	43
Serial Port Configuration Of The Master.....	43
Data Packet.....	43
The Query.....	44
The Response .....	44
Data Field.....	44
Error Checking .....	44
ASCII.....	44
RTU .....	44
Framing.....	45
ASCII.....	45
RTU .....	45
ASCII Query (Read) Example.....	46
ASCII Write Example .....	47
ASCII Response Example .....	49
RTU Query (Read) Example .....	50
RTU Response Example.....	50
Modbus® Notes .....	50
Modbus® Data Access .....	50
Profinet .....	51
General Description .....	51
<b>HYPERTERMINAL</b> .....	<b>52</b>
Description .....	52
Setting up Hyperterminal.....	52
Testing Communications .....	57
General Notes.....	57
<b>CONVERSION CHART FOR DECIMAL / HEXADECIMAL / ASCII</b> .....	<b>59</b>
<b>QUANTUM™ LX DATA TABLES</b> .....	<b>60</b>
Digital Board Values .....	60
Analog Board Values .....	63
Calculated Values .....	66
Mode Values .....	68
Setpoint Values .....	77
Warning/Shutdown Message Codes .....	101
<b>QUANTUM™ 4 MAIN BOARD HISTORY AND IDENTIFICATION</b> .....	<b>107</b>
Serial Communications Port Wiring.....	109
RS-232 Wiring And Jumpers .....	109
Com-2 (TB3) .....	109
Com-3 (PL6) .....	109
RS-422 Wiring And Jumpers.....	110
Com-1 (TB1) .....	110
Com-2 (TB2) .....	110
RS-485 Wiring And Jumpers.....	111
Com-1 (TB1) .....	111
Com-2 (TB2) .....	111
Serial Communications Troubleshooting .....	112
RS-232 .....	112
Com-2 (TB3) .....	112
RS-422.....	112

Com-1 (TB1) .....	112
Com-2 (TB2) .....	112
RS-485 .....	113
Com-2 (TB1) .....	113
Com-2 (TB2) .....	113
<b>COMMUNICATIONS DATA LOGGING SCREENS .....</b>	<b>114</b>
Communications Log .....	114
Modbus TCP Log .....	114
<b>COMMUNICATIONS LOOPBACK TEST .....</b>	<b>115</b>
Description .....	115
Hardware Setup For Testing	
RS-232 .....	115
RS-422 .....	115
RS-485 .....	115
Software Setup For The Communications Loopback Test .....	116
Performing The Communications Loopback Test .....	117
<b>APPENDIX A .....</b>	<b>118</b>
Frick® Serial Communications Converter Module .....	118
Description .....	118
Setting The Dipswitch .....	118
Mounting The Module .....	118
Wiring The Module .....	119
RS-232 Connections .....	119
RS-422 Connections .....	119
RS-485 Connections .....	119
<b>APPENDIX B .....</b>	<b>120</b>
Quantum™ LX Ethernet Communications Wiring .....	120
<b>APPENDIX C .....</b>	<b>121</b>
Quantum™ LX Local Ethernet Configurations .....	121
<b>APPENDIX D .....</b>	<b>122</b>
Quantum™ LX Ethernet Network Configurations .....	122
<b>APPENDIX E .....</b>	<b>123</b>
Quantum™ LX Serial Communications Wiring .....	123
Serial Communications Wiring Diagrams .....	126
To Customer Remote Computer/DCS .....	126
RS-485 Communications .....	126
RS-422 Communications .....	126
<b>INDEX .....</b>	<b>127</b>

The Quantum™ has the capability of being modified by the user/owner in order to obtain different performance characteristics. Any modification to the standard default settings may have a severe negative impact on the operation and performance of the equipment. Any modification to these control settings is the sole responsibility of the user/owner and Johnson Controls disclaims any liability for the consequences of these modifications. It is possible that the modification of these settings may cause improper operation and performance that result in property damage, personal injury or death. It is the responsibility of the user/owner to evaluate and assess the consequences of their actions prior to modifying the controls for this unit.

## INTRODUCTION TO THE QUANTUM™ LX

### QUANTUM™ DESCRIPTION

The Quantum™ LX control panel utilizes the Quantum™ 4 microprocessor board as the brains of the system. The LX portion of the Quantum™ name actually refers to the operating system (software), and the operator interface (physical display and keypad). When you see the name Quantum™ 4, the physical hardware of the controller is being referred to (microprocessor), whereas Quantum™ LX refers to the software, and how the operator interacts with the software (through the display/keypad).

As an example, the Quantum™ 4 controller contains the physical Ethernet and Serial connections that the user connects to, while the Quantum™ LX software determines how those connections are used.

These connections are known as *PROTOCOLS*, and are both hardware and software based. The hardware portion of the protocol (Quantum™ 4) tells how the wiring connections are physically made, while the software portion (Quantum™ LX) tells how the data to the connection is to be formatted and interpreted.

The Quantum™ LX software is based on a Web Browser format, and has the capability of communication through both Ethernet and Serial Ethernet protocols.

The following screen is representative of what the operator will see when the unit is first powered up. This is called the Home screen. Be aware that the content of this screen may differ from situation to situation, based upon the actual configuration and installed options.



The Operating (or Home) screen

### HOW TO USE THIS MANUAL

The purpose of this manual is provide the necessary information (protocols, data registers, wiring, etc.) to allow the end user to reliably communicate with the Quantum™ LX via various communications methods (to be described later) for the purpose of obtaining and sending data and/or for compressor control.

The Quantum™ LX does NOT begin any communications conversations on its own, it only responds to queries (requests) from external devices.

For Ethernet communications, refer to the section entitled *Ethernet and Networking*. Ethernet does not require any jumpers to be installed.

For serial communications connections, refer to the section entitled *Quantum™ Serial Communication* for the correct wiring and jumper settings of RS-232, RS-422, or RS-485. Also, refer to the drawing of the *Quantum™ 4 Main Board* section to identify wiring configurations for Com-2.

For information on software protocols, refer to the section entitled *Protocol Description*.

To access specific data within the Quantum™ LX, refer to the *Data Tables*.

## ETHERNET AND NETWORKING

### DESCRIPTION

Frick® Controls uses Ethernet as the primary method of connecting one or multiple Quantum™ LX panels to a common computer network. In the past, this interconnection would have been done by serial protocol wiring, such as RS-232/422/485. But with the capabilities of today's technology, Ethernet is the quickest and most efficient way of providing this interconnectivity.

Whereas the old serial communications methods (RS232, etc.) were slow by today's standards (kilobits per second transmission speed), Ethernet is available in two speeds: 10 Mbps and 100 Mbps.

**NOTE:** For connection examples, refer to the section of this manual entitled *Quantum™ LX Local Ethernet Configurations* and *Quantum™ LX Ethernet Network Configurations*.

Ethernet is a data and information sharing system. To put it simply, it is a method of connecting one computer to many others on a common network. This network can consist of both hardwired connections, and wireless devices, hence the name *ETHERNET*.

Any Windows or Linux based computer is capable of accessing this network. All that is needed is either a modem, USB port, or an Ethernet port. These devices provide the necessary point of connection for one end (branch) of the connection (a home computer for instance). The other point that completes the connection is usually provided by an *Internet Service Provider* (or *ISP*). The *Internet Service Provider* usually has a very large network router, or means of bring in many individual connections. The router then assigns a discrete and individual address to each connection (much like a street address). This address is known as an *Internet Protocol address (IP)*. The IP address consists of a series of 4 to 12 digits, and is normally transparent to the end user.

For those individuals familiar with using the internet, they are familiar that every time they activate their web browser (the software that allows your computer to connect), there is an address bar that appears near the top of the screen. This address bar is where you would enter the IP address of the computer or network that you would like to communicate with. To make this simpler, these numeric IP addresses are also coded to allow alpha-numeric names to be masked over them, so that rather than having to enter an address of 216.27.61.137, you can simply enter in *www.jci.com*, as an example. Although the actual process is more detailed and complicated than this basic explanation, the end result is that most of the work is being done invisibly.

The following write up describes how to set up the Quantum™ LX to do this *behind the scenes* work, so that it can communicate both at the Internet level, and at a local Ethernet level.

### CABLING

Each Quantum™ LX Ethernet connection must be individually cabled (known as a *homerun*) direct from a switch or computer. Unlike RS422/485 communications which allowed for cable daisy-chaining, Ethernet connections do not allow this.

This type of cabling is designed to handle the 100-Mbps speed needed by Ethernet. Both ends of each cable must have an RJ-45 connector attached. The RJ-45 connector looks similar to the RJ-11 connector on the end of a telephone cord but is slightly larger (and not compatible). You can buy Cat 5 cables in predetermined lengths with the connectors already attached (for short runs), or you can buy the cable in rolls, cut it to length and install the RJ-45 connectors to the ends (up to 100 meters per each cable run).

Although Frick® Controls recommends the use of shielded, twisted pair Cat 5 cable, if the cable is not properly constructed and tested, it can actually be more detrimental to the network than unshielded cable. As long as all of the cables that are used have been properly constructed AND tested, either shielded or unshielded are acceptable. This is mostly due to the excellent (electrical) noise immunity that is inherent with Ethernet componentry.

**NOTE:** Follow standard networking procedures for the interconnections of all components. For individual cable runs in excess of 300 feet (~100 meters), a *Switch/Hub* must be used for each additional run.

**Cabling Do's and Don'ts** – Frick® Controls recommends the following guidelines when installing and using CAT 5 Ethernet cable:

#### Do:

- Do run all cables in a star (homerun) configuration.
- Do keep all individual cable lengths under 300 feet. If greater distances are needed, use a switch/hub every 300 feet.
- Do ensure that the twists of the wire pairs within the cable are maintained from end to end.
- Do make gradual bends in the cable. Keep each bend radius over one inch.
- Do keep all cables tie wrapped neatly.

- Do try to maintain parallel cable runs where possible.
- Do keep the cable as far away as possible from EMI sources (motors, transformers, solenoids, lighting, etc.)
- Do label the ends of each cable, to facility troubleshooting and identifying in the future.
- Do test each individual cable run with an approved CAT5 E cable tester. A TONING alone test is NOT acceptable.
- Do use rubber grommets anywhere that the cable enters through a hole in a metal panel.
- ALWAYS obey local, national and fire building codes.

**Don't:**

- Don't install cable taut, cables must always have some "play" or slack in them.
- Don't over-tighten cable ties.
- Don't splice a cable. If a break occurs, or the length is not long enough (under 300 feet), replace the entire run with an intact length.
- Don't tie cables to electrical conduits.
- Don't strip more than one inch from the end of each cable when installing end connectors.
- Don't sharply bend or kink the cable.
- Don't mix 568A and 568B wiring at the same installation. 568B is the most common wiring.
- Don't use excessive force when pulling cable.

**RJ-45 CONNECTORS**

Ethernet network cables require the use of industry standard RJ-45 plugs as shown below, for the termination of all cables:



**Typical RJ-45 Connector**

When looking at this connector, pin 1 is at the left, and pin 8 is at the right.

**THE HUB**

A Hub is a common connection point for devices in a network. Hubs are commonly used to connect segments of a LAN (Local Area Network). They also contain multiple ports. When a data packet arrives at one port, it is copied to the other ports so that all segments of the LAN can see all packets.

**THE SWITCH**

Network Switches look nearly identical to hubs, but a switch generally contains more intelligence than a hub. Unlike hubs, network switches are capable of inspecting the data packets as they are received, determining the source and destination device of a packet, and forwarding that packet appropriately. By delivering messages only to the connected device that it was intended for, network switches conserve network bandwidth and offer generally better performance than hubs.

The Switch takes the signal from each computer/Quantum™ LX and sends it to all of the other computers/LX panels in your plant or office. Switches come in several sizes, noted by the number of ports available -- a four-port Switch can connect four computers, an eight-port Switch can connect up to eight computers and so on. So, if you start with a four-port Switch but eventually add more panels, you can buy another Switch and connect it to the one you already have, increasing the potential number of panels on your network.

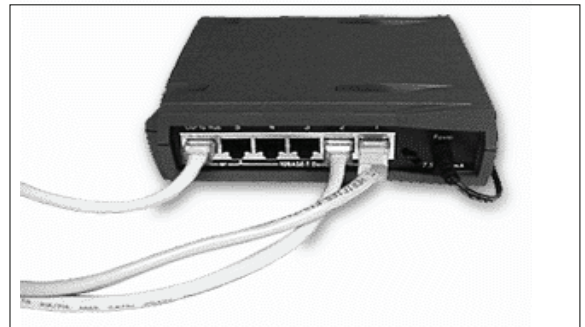

**Typical Switch**

**Note:** If you want to connect one computer to one Quantum™ LX, you can avoid the switch and use a crossover Cat 5 cable. With a crossover cable, you directly connect one Ethernet device to the other without a Switch. To connect more than two you need a Switch.

Refer to the following pictorial to construct a crossover cable:

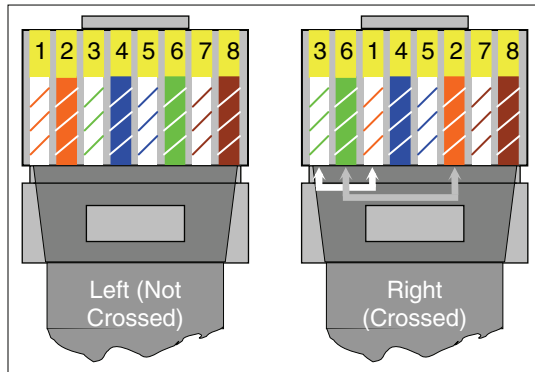

Both Ends of a crossover-cable

CAT-5 Ethernet cable color codes

- |                           |                          |
|---------------------------|--------------------------|
| 1 – White w/orange stripe | 5 – White w/blue stripe  |
| 2 – Orange w/white stripe | 6 – Green w/white stripe |
| 3 – White w/green stripe  | 7 – White w/brown stripe |
| 4 – Blue w/white stripe   | 8 – Brown w/white stripe |

Because of the large number of possible configurations in an Ethernet network, you most likely will not have any type of automated installation software. This means that you will need to manually configure all the options. To configure these options for the Quantum™ LX, please refer to the next section in this manual entitled *Ethernet Setup*.

ETHERNET COMPONENT RECOMMENDATIONS

Component	Description	Part Number	Manufacturer
Cable	Shielded solid 4-pair* (1000 Ft)	BOXCAT5E-DSSO	Cablesforless.com
	Shielded solid 4-pair*	E-PLG-SOLID-SH	VPI
		CR45-100S	Cables Direct
	Un-shielded solid 4-pair**	9504 CS	Alpha Wire Co.
		9504 F	
		E-PLG-SOLID	VPI
Un-shielded solid 4-pair** (1000 Ft)	345U5-1000BLK	Ram Electronics	
	0-5EPCS-BK	Computercablestore.com	
Crimp Tool	RJ-45 Crimp tool	HT-210C	Cablesforless.com
		P-15027	Stonewall Cable, Inc.
		S2307692	Computers4sure.com
		10-RJ1145	Computercablestore.com
Connectors	RJ-45 For Shielded 4-pair solid wire cable	P-15007	Stonewall Cable, Inc.
	RJ-45 For Un-shielded 4-pair solid wire cable	5-554169-3	Tyco Electronics
		1-5E45-010	Computercablestore.com
Cable Tester	Ethernet Cable Tester – Continuity only	TST-5150	Cablesforless.com
	Complete Cable I/O Qualification Tester	TS075A-R2	Black Box
Switches	5 RJ-45 port	SFN-5TX	Phoenix
	7 RJ-45 Port and 1 ST Fiber Optic Port	SFN-7TX/FX ST	Phoenix
	8 RJ-45 port	SFN-8TX	Phoenix

\* STP = Shielded Twisted Pair  
\*\* UTP = Unshielded Twisted Pair

## ETHERNET SETUP

Once all of the cabling has been run and all connections have been made, it is now necessary to setup the Quantum™ LX software to recognize and handle the Ethernet connection.

The following section describes the suggested panel setup for connecting the Quantum™ LX panel to an existing Ethernet connection:

**ACCESSING:**  → **Configuration ...** → **Ethernet**

**DESCRIPTION:** This screen is used to allow the user to assign and setup Ethernet and Email communications parameters.

### IP DATA

**Address Type** - The following drop-down menu is provided:

- **Fixed (Static)** - A fixed address is usually assigned by the network (LAN) administrator, and is normally always the same.
- **DHCP (Dynamic)** - Dynamic Host Configuration Protocol permits auto-assignment of temporary IP addresses for new devices connecting to the network.

**IP Address** - (Internet Protocol) Four setpoint boxes are provided here. Every device on an Internet or Ethernet network must be assigned a unique identifying number, called an IP Address (this is similar in concept to the Quantum™ LX panel ID number). The IP address is how the network identifies each device that is attached. A typical IP address would look like this:

- 216.27.61.137

**Gateway Address** - Four setpoint boxes are provided here. This is the IP address for the computer or device onto which your local network is connected to.

This gateway device is how all of the devices attached to your local network are routed to other gateways and networks. A router is a Gateway device that routes packets between different physical networks. A gateway is a network point that acts as an entrance to another network.

**Subnet Mask** - A TCP/IP number used to determine to which TCP/IP subnet a device belongs. Devices in the same subnet can be communicated with locally without going through a router (to the outside world). When a TCP/IP device tries to communicate with another device the bits of the TCP/IP destination address are "ANDed" with the subnet mask to determine whether the address is a local address (broadcastable) or must be reached through a router. A subnet mask of 255.255.255.0 used by a computer with a TCP/IP address of 10.10.10.1 would include the addresses 10.10.10.0 through 10.10.10.255 in the local network, basically telling the computer to try a router if it's transmitting to any other IP address. This is all part of the TCP/IP protocol.

**Web Server Port** - This is the port, or channel, that a web server uses to communicate through. Just as a computer sends data to a printer through a printer port, a web server sends and receives data through

the Web Server Port. By default, the port number for a Web server is 80.

## NAMING DATA

**NOTE:** The IP Address Type must be set to DHCP (Dynamic) for this section to work.

**Host Name** – Enter a distinct name that you wish to be able to identify this particular compressor by (for example; Unit1). The Host Name must be fifteen characters or less in length, use no spaces and use only upper and lower case letters. It is similar in concept to the function of the Panel ID, and basically allows the network router to interpret the actual IP address of a particular unit as this host name. When using a web browser within the system network, this name can be entered as the web location that you wish to visit (instead of having to type in the IP address). After modifying a Host Name, you will be required to cycle power. The network router could take up to fifteen minutes to recognize the change.

**Work Group** – All of the Quantum™ LX units within a network may be grouped into different categories. These categories could be unit locations, or perhaps categorized by unit function. For instance, if you wanted to group the units by function, and had 10 units, and three of them were Evaporators (located on the roof), then Evap1 could be the name of a work group. Another three units may be High Stage compressors, this work group could be named HighStage1, and the remaining four units could be standard compressors, and they could be named Comp1. So name each unit by these functional Work Group names. The Work Group name must be fifteen characters or less in length, and can use numerals and upper and lower case letters. When using the network neighborhood feature of Windows® Explorer, by looking at your Network Neighborhood, you would see the name of the Work Group, and within that work group you would see the individual Host Names of each unit within that work group. After modifying a Work Group name, you will be required to cycle power. The network router could take up to fifteen minutes to recognize the change.

**Server String** – This is a comment area that can be used in conjunction with the Host Name. For example, if the Host Name is *Booster1*, you could set the Server String to print something like *DockBooster*, or some other additional information about the unit. The Server String has no control function; it is strictly an informational area.

## E-MAIL DATA

The purpose of the E-Mail data feature is to allow the controller to send a Warning or Shutdown message to defined listing of recipients.

**Email Notification On Warning Or Shutdown** – For the E-mail notification feature to work, it must be enabled (it is disabled as a default). The following drop-down menu is provided:

- Disabled
- Enabled

**Local Email Address** – Use this setpoint box to enter a valid E-mail address that has been assigned to the internet account.

**Alias Name For Local Email Address** – Enter here a custom name to identify more clearly the local Email address. When a message is sent to all recipients, this is the name that will appear in the Email *FROM* column.

**Subject** – Enter a custom subject that you would like to appear when a message failure is sent. When a message is sent to all recipients, this is the wording that will appear in the Email *SUBJECT* column.

**SMTP Server Name OR IP Address** – SMTP stands for Simple Mail Transfer Protocol. SMTP servers handle outgoing email, and accept email from other domains. When you set up an email client, you must specify an *outgoing server* (sometimes called an *SMTP server*). Often, this server is designated in the form of smtp.domain.com. But this can vary, so be sure to check with your email service provider or LAN administrator to find out their outgoing server.

**SMTP Server Port Number** – This value is in almost all cases going to be 25. This should be set by the network or LAN administrator.

**Comma-Delimited List Of Email Recipients** – This is simply the list of the Email addresses that you would like to have any messages sent to. Separate each e-mail address with a comma.

## PROTOCOLS

The purpose of this section is to enable or disable the Modbus TCP, Ethernet/IP and Profinet parameters.

### Modbus TCP:

- Disabled
- Enabled

### Ethernet/IP:

- Disabled
- Enabled

### Profinet:

- Disabled
- Enabled

## SERIAL COMMUNICATIONS

### GENERAL DESCRIPTION

Serial communications to and from the Quantum™ LX can use RS-232, RS-422 and/or RS-485 hardware protocol. These three hardware protocols can be connected via Com-1 and Com-2 for RS-422/485, and Com-2 and Com-3 for RS-232. The reason that Com-2 can be either RS-232 or RS-422/485 will be explained in the section entitled *Com-1 and Com-2 Description*.

The Com-1 and Com-2 serial communications portion of the Quantum™ controller consists of a daughter

board, mounted to the main controller. In addition to external forms of serial communication (to be discussed shortly), the keypad also connects here. Refer to the following pictorial of the Com-1 and Com-2 communications daughter board.

Com-3 is another serial port (RS-232) that may be used in addition to Com-1 and Com-2. The location of Com-3 is on the main processor board and will be explained in the section entitled *Com-3 Description*.

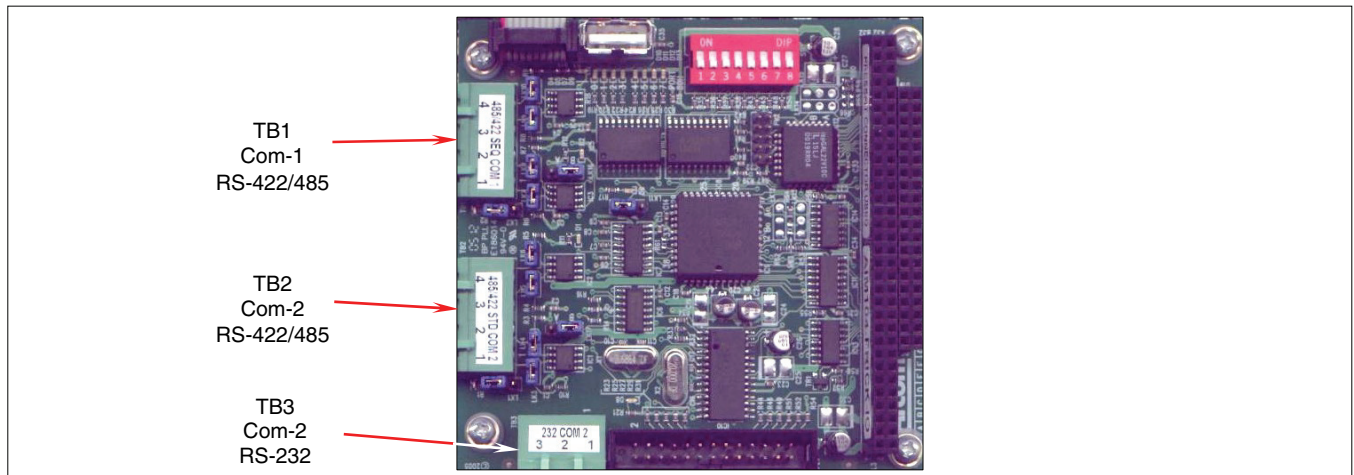

Com-1 and Com-2 Ports on the Daughter Board

### COM-1 AND COM-2 DESCRIPTION

The board pictured above actually has three serial communications ports (labeled as TB1, TB2 and TB3). TB1 is known as Com-1, and is reserved solely for RS-422/485 communications. It can be used for external communications to the outside world.

TB2 is known as Com-2. However, TB3 is also known as Com-2. The difference here is that TB2 is for RS-422/485 whereas TB3 is for RS-232. TB2 can be used in the same manner as TB1.

When TB2 (Com-2) is setup to be used for RS-422/485, then

TB3 cannot be used for RS-232, and vice-versa. The reason for this is that there is a jumper (LK11) that needs to be properly set that will tell the controller which of the two ports will be used (either TB2 as RS-422/285 OR TB3 as RS-232).

### COM-3 DESCRIPTION

Com-3 (PL6) is used for RS-232 hardware protocol only, and can be used in addition to any of the other communications ports that may be being used. So it is possible to have two RS-232 ports active (Com-2 AND Com-3) at the same time, as well as Com-1 for RS-422/485.

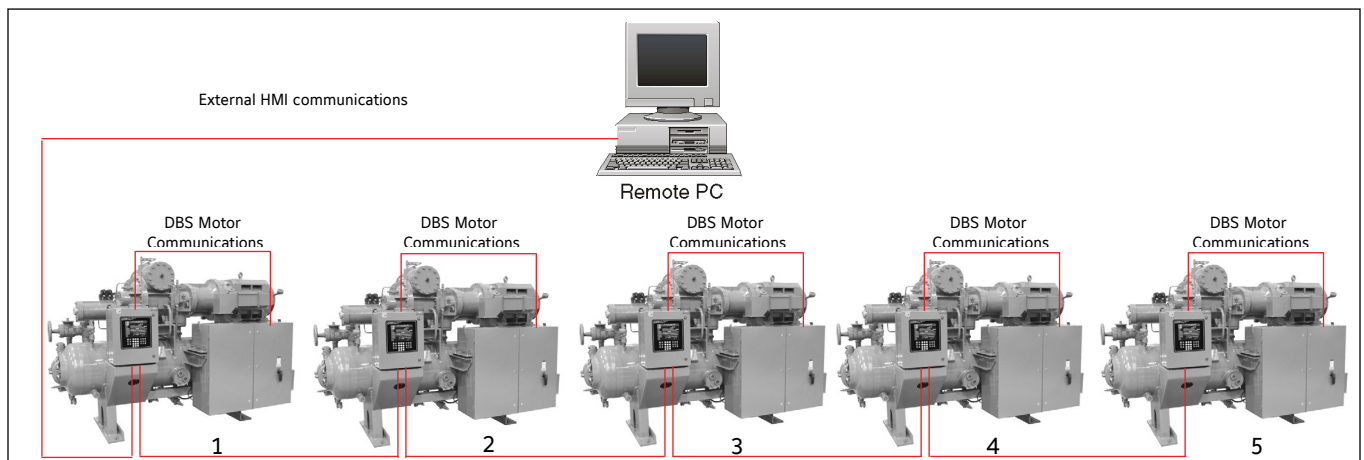

Typical Serial Wiring Scenario including optional DBS Motor Starter

## RS-232 DESCRIPTION

RS-232 is by far the most common (and oldest) serial communications hardware protocol, as almost all laptop and desktop computers will have at least one RS-232 serial communications port available. It was initially developed for the emerging computer industry in the 1960's. Originally, it was a method of sending data from a mini or main frame computer, to devices such as printers, punch card readers, teletypes, magnetic tape units and modems. In those early days, the maximum speed at which RS-232 was capable of transmitting (about 9600 bits per second), was quite satisfactory, as most of the receiving devices were mechanical in nature (except for modems), and barely able to keep up with these speeds.

RS-232 uses single ended TX (transmit data) and RX (receive data). This means a common ground wire is shared between TX and RX, so only 3 wires are needed or a data only serial channel: TX, RX, and GND.

Disadvantages of single ended signaling is that it is more susceptible to noise than differential signaling (RS-422/485), effective cable distances are shorter (typically about 50 Ft. total, due to low noise immunity) and data rates are slower. Additionally, there is the limitation that only two devices can communicate together (master and slave).

The Quantum™ controller has two RS-232 ports available. One of these is TB2 (Com-2), the other is PL6 (Com-3), as shown on the following pictorial. Both TB2 (Com-2) and PL6 (Com-3) may be used concurrently.

RS-232 signals cannot be connected directly to either an RS-422 or RS-485 device. These signals must first be conditioned (converted). See the section entitled *Converting an RS-232 Signal to RS-422/485* for details.

## RS-422/RS-485 DESCRIPTION

When serial communications started moving into the industrial environment, it was quickly noted that because of the high electrical noise potential from electric motors, valves, solenoids, fluorescent lighting, etc., that the noise immunity characteristics of RS-232 protocol was grossly lacking. Additionally, the distances between the communicating equipment on the factory floor was much greater than that within the typical office environment. For these reasons, RS-422 and RS-485 was developed.

- RS-422 is a full duplex communications hardware protocol. This means that it data can be sent and received simultaneously. Frick® Controls uses a 4-wire system for RS-422 (two transmit wires and two receive wires). Advantages of RS-422 over RS-232 is that up to 30 Quantum™ controllers may be simultaneously connected using a daisy-chain wiring scheme (to be explained later), and that the distances involved can be much greater (typically up to 2000 ft. for the total cable run), much greater noise immunity than RS-232.
- RS-485 is a half duplex bus. This means that it can only send data, or receive data at any given time. It cannot do both at the same time. Frick® Controls uses a 2-wire system for RS-485 one positive transmit/receive wire and one negative transmit/receive wire). Up to 30 Quantum™ controllers may be simultaneously connected up to a total distance of 2000 ft. using a daisy-chain wiring scheme (to be explained later). One advantage to using RS-485 as opposed to RS-422 is that only a single twisted pair cable need to be run to all devices (while RS-422 requires a double twisted pair cable), much greater noise immunity than RS-232.

RS-422/RS-485 signals cannot be connected directly to an RS-232 device. These signals must first be conditioned (converted). See the section entitled *Converting an RS-232 Signal to RS-422/485* for details.

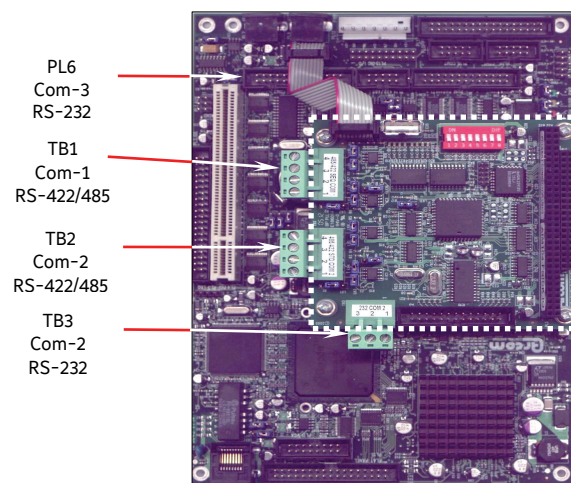

Serial Communications Port Locations

## SERIAL COMMUNICATIONS SETUP

After the serial communications wiring has been connected, and jumpers correctly set, the LX software needs to be setup to match that of the device(s) that it is

to communicate with. The following screen is where this information can be found:

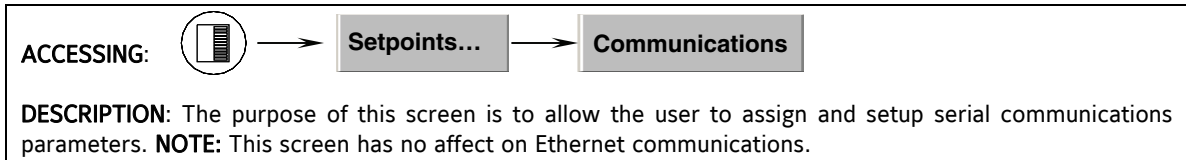
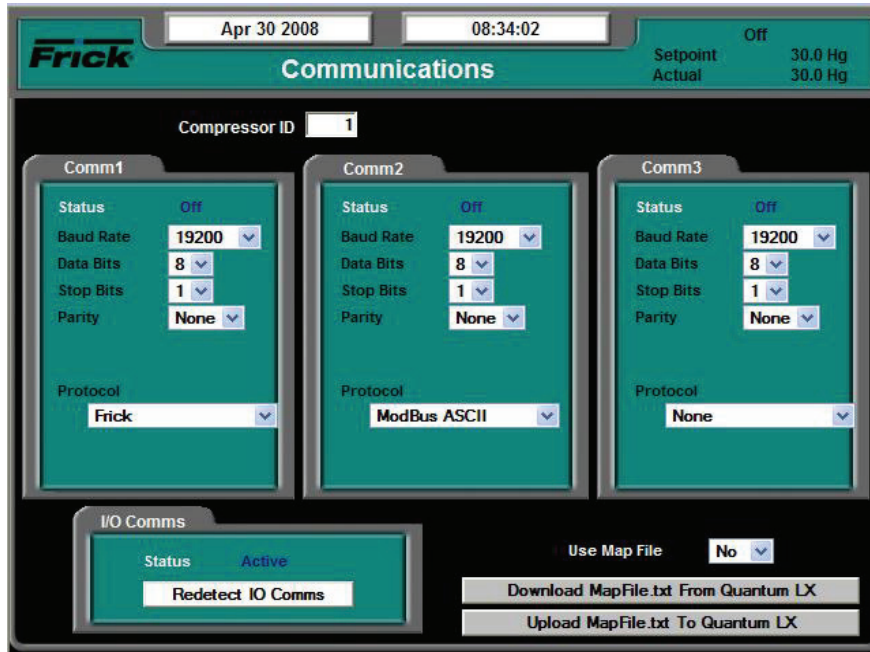

The following setpoints are provided:

**Compressor ID** - A number that is used by an external communications application, to converse to individual compressors. On interconnected systems, this number must be unique. Valid values are from 1 - 99.

**Comm1** - (Setup parameter definitions for Com-1 and Com-2 are identical) Communications related information for the communications ports:

**Status** - Shows the current communications status of the port. The possible messages are:

- **Off** - No communications are currently taking place. NOTE: A delay of 15 seconds or more of inactive communications (time between valid responses) will cause this message to display.
- **Active** - Valid communications are actively occurring.
- **Failed** - An invalid command was received by the port. This could be due

to a bad checksum value, a wiring issue, or hardware problem at either the transmitting (host) or receiving (Quantum™ LX) end.

**Baud Rate** - The baud rate defines the speed at which external communications can occur. The higher the baud rate, the faster the communications. It is best to start out using a lower baud rate, and increasing the value only after verifying that communications errors do not occur. If errors start to occur, drop the baud rate back down. A pull down menu is provided to select from the following:

- 1200
- 2400
- 4800
- 9600
- 19200
- 38400
- 57600
- 115200

**Data Bits** - Determines the number of bits in a transmitted data package. A pull down menu is provided to select from the following:

- 7
- 8

**Stop Bits** - A bit(s) which signals the end of a unit of transmission on a serial line. A pull down menu is provided to select from the following:

- 1
- 2

**Parity** - In communications, parity checking refers to the use of *parity bits* to check that data has been transmitted accurately. The parity bit is added to every data unit (typically seven or eight data bits) that are transmitted. The parity bit for each unit is set so that all bytes have either an odd number or an even number of set bits. Parity checking is the most basic form of error detection in communications. A pull down menu is provided to select from the following:

- None
- Even
- Odd

**Protocol** - A protocol is the special set of rules that each end of a communications connection use when they communicate. A pull down menu is provided to select from the following Frick recognized protocols:

- None
- Frick
- ModBus ASCII
- ModBus RTU
- AB DF1 Full Duplex
- AB DF1 Half Duplex
- DBS Motor Starter
- Vyper

**Map File** - Because the addressing scheme between the Quantum™ version 5.0x and earlier software and the Quantum™ LX version 6.0x and later software is not the same, this file was created. The map file is a conversion utility that can be used to allow a communications application that was previously written by the user under the Quantum™ version 5.0x and earlier to function properly with the Quantum™ LX by redirecting the old addresses to the new addresses (see the section entitled *Using the MAP file* for additional information). A pull down menu is provided to select from the following:

- **No** - Do not use map file, the user is either not going to be using external communications, or they will be writing

the communication application based upon the Quantum™ LX addresses.

- **Yes** - The user has an application that was previously written for the Quantum™ version 5.0x or earlier, and they want to utilize the same code for the Quantum™ LX.

**I/O Comms** - A status indicator is provided to show the current state of the internal communications of the I/O boards. The possible displayed states are:

- **Off** - Loss of or intermittent communications failures to the internal Quantum™ LX I/O boards.
- **Active** - Indicates that normal I/O communications are occurring.
- **Failed** - Loss of communications, a shutdown message will be generated.

**Redetect IO Comms** - Select this key to detect all connected Analog and Digital boards. If a board has been removed, a communication error shutdown will be issued until this key is selected. Reference the *About* screen to view what has been detected.

Two keys are located at the bottom right hand side of the screen. The following describes there function:

**Download MapFile.txt from Quantum™ LX** - With a USB memory stick installed on the LX, pressing this key will cause the MapFile.txt file to be downloaded from the Quantum™ LX into the USB memory.

**Upload MapFile.txt to Quantum™ LX** - After the user has modified the MapFile.txt file to suit their needs, pressing this key will cause the file to be uploaded from the USB memory back into the Quantum™ LX.

## USING THE MAP FILE

The MAP file is simply a text file (map.txt), which can be downloaded from the Quantum™ panel. The file can be used in its original format, which contains a limited number of addresses, or may be modified by the user, to incorporate additional addresses.

### Downloading The Map File From The Quantum™ LX Through a Web Browser

To download the map file from the Quantum™ LX controller, click the Download button. A new box will appear with a link labeled MapFile.txt. Right click on the link, and select Save Link Target As... from the menu. The web browser will then present a dialog box allowing the user select a location on their computer for the map file to be stored. (NOTE: This operation is not

intended to be performed from the Operator Interface Panel. Instead, a desktop computer should be used to access the Evaporator controller via a web browser).

**Downloading the MAP File From the Panel Using a USB Memory Stick**

Two keys are located at the bottom right hand side of the screen. The following describes there function:

**Download MapFile.txt from Quantum™ LX –**  
With a USB memory stick installed on the

LX, pressing this key will cause the MapFile.txt file to be downloaded from the Quantum™ LX into the USB memory.

**Upload MapFile.txt to Quantum™ LX –** After the user has modified the MapFile.txt file to suit their needs, pressing this key will cause the file to be uploaded from the USB memory back into the Quantum™ LX.

A sample of the original file appears in the following example:

;Quantum to Quantum LX MAP Addresses		
;Q, LX ,		LX Description
0, 1026		;Compressor Motor Start Signal
1, 1027		;Compressor Motor Starter-Feedback/Compressor Interlock
2, 1028		;Oil Pump Start Signal
3, 1029		;Oil Pump Feedback
4, 1003		;Capacity Increase
5, 1002		;Capacity Decrease
6, 1005		;Volume Increase
7, 1004		;Volume Decrease

Quantum™ Version 5.0 and earlier addresses →

Quantum™ LX addresses →

Quantum™ LX Address Description →

**MapFile.txt Example**

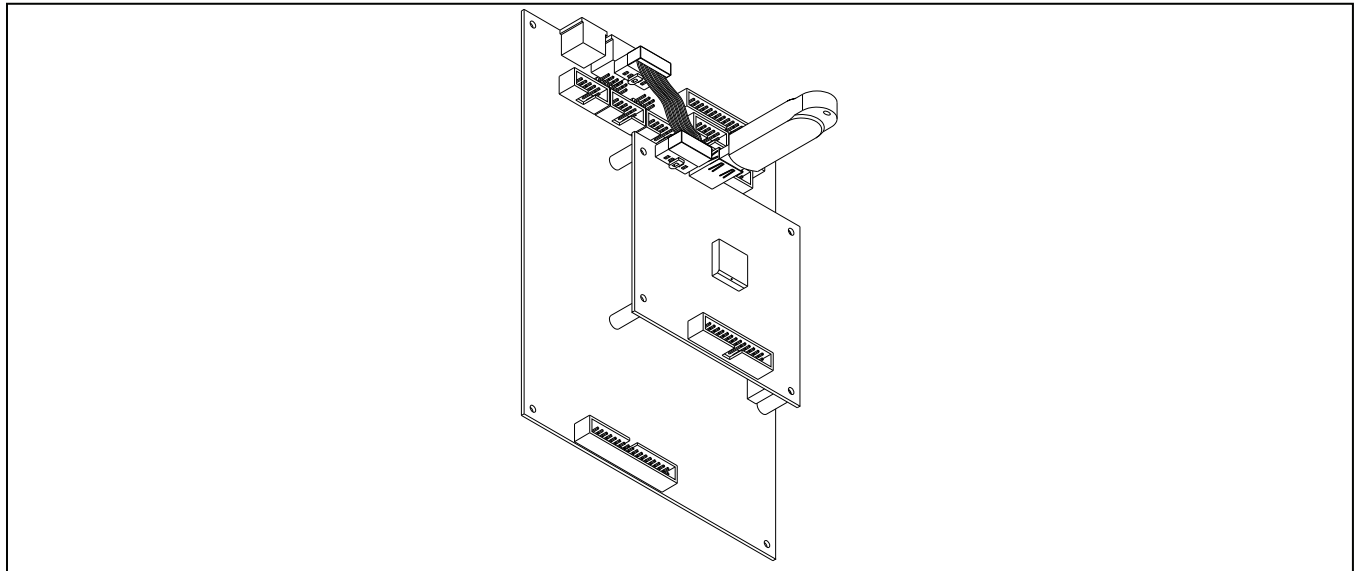

**USB Memory Stick plugging in directly with no adapter**

**SERIAL COMMUNICATION SETUP TABLE**

Use the following form to record all settings:

**SERIAL COMMUNICATION SETUP**

Compressor ID	_____ (0 - 255)		
	Com 1	Com 2	Com 3
Baud Rate	<input type="checkbox"/> 1200 <input type="checkbox"/> 2400 <input type="checkbox"/> 4800 <input type="checkbox"/> 9600 <input type="checkbox"/> 19200 <input type="checkbox"/> 38400 <input type="checkbox"/> 57600 <input type="checkbox"/> 115200	<input type="checkbox"/> 1200 <input type="checkbox"/> 2400 <input type="checkbox"/> 4800 <input type="checkbox"/> 9600 <input type="checkbox"/> 19200 <input type="checkbox"/> 38400 <input type="checkbox"/> 57600 <input type="checkbox"/> 115200	<input type="checkbox"/> 1200 <input type="checkbox"/> 2400 <input type="checkbox"/> 4800 <input type="checkbox"/> 9600 <input type="checkbox"/> 19200 <input type="checkbox"/> 38400 <input type="checkbox"/> 57600 <input type="checkbox"/> 115200
Data Bits	<input type="checkbox"/> 7 <input type="checkbox"/> 8	<input type="checkbox"/> 7 <input type="checkbox"/> 8	<input type="checkbox"/> 7 <input type="checkbox"/> 8
Stop Bits	<input type="checkbox"/> 1 <input type="checkbox"/> 2	<input type="checkbox"/> 1 <input type="checkbox"/> 2	<input type="checkbox"/> 1 <input type="checkbox"/> 2
Parity	<input type="checkbox"/> None <input type="checkbox"/> Even <input type="checkbox"/> Odd	<input type="checkbox"/> None <input type="checkbox"/> Even <input type="checkbox"/> Odd	<input type="checkbox"/> None <input type="checkbox"/> Even <input type="checkbox"/> Odd
Protocol	<input type="checkbox"/> None <input type="checkbox"/> Frick <input type="checkbox"/> Modbus ASCII <input type="checkbox"/> Modbus RTU <input type="checkbox"/> AB DF1 Full Duplex <input type="checkbox"/> AB DF1 Half Duplex <input type="checkbox"/> DBS Motor Starter <input type="checkbox"/> Vyper	<input type="checkbox"/> None <input type="checkbox"/> Frick <input type="checkbox"/> Modbus ASCII <input type="checkbox"/> Modbus RTU <input type="checkbox"/> AB DF1 Full Duplex <input type="checkbox"/> AB DF1 Half Duplex <input type="checkbox"/> DBS Motor Starter <input type="checkbox"/> Vyper	<input type="checkbox"/> None <input type="checkbox"/> Frick <input type="checkbox"/> Modbus ASCII <input type="checkbox"/> Modbus RTU <input type="checkbox"/> AB DF1 Full Duplex <input type="checkbox"/> AB DF1 Half Duplex <input type="checkbox"/> DBS Motor Starter <input type="checkbox"/> Vyper
Map File	<input type="checkbox"/> No <input type="checkbox"/> Yes	<input type="checkbox"/> No <input type="checkbox"/> Yes	<input type="checkbox"/> No <input type="checkbox"/> Yes

## SERIAL PROTOCOL

### DESCRIPTION

The use of serial communication protocols permits data transmission between devices. Protocol determines how contact is established and how the query (question) and response (answer) takes place. The information in a message command requires:

- The identity of the intended receiver (ID #)
- What the receiver is to do (read or write to a setpoint, etc.)
- Data needed to perform an action (the value of a setpoint to be changed)
- A means of checking for errors (checksum).

When using any of the communications ports, check what communication protocol has been selected from the **Communications** screen. The baud rate, data bits, stop bits, parity and connection type of all comm. ports, as well as the panel ID number are also changed from this screen, and should coincide with the setup of the other device.

**Note:** The data communication protocols are continuously being expanded and improved. Therefore, you should consult Frick® Controls for the exact details on your particular unit(s) before developing system software to interface with the panel.

### QUANTUM™ LX COMMUNICATIONS PROTOCOL LIST

The Quantum™ LX controller has the capability of communicating to the outside world through the following software protocols:

- Frick®
- Allen-Bradley DF-1 Full Duplex
- Allen-Bradley DF-1 Half Duplex
- Modbus ASCII
- Modbus RTU
- Modbus TCP
- Ethernet/IP

### CHECKLIST FOR SETTING UP COMMUNICATION

1. Decide which Quantum™ protocol you can communicate with and want to use.
2. Setup your device's communication port with the proper parameters and select a baud rate.
3. Next, setup the Quantum™ LX for the desired communication protocol. Select the protocol from the **Communications** screen.
4. Setup the baud rate of the Comm Port to coincide with the setup of your device's communication port.
5. Enter the Quantum™ LX ID. This will be used to identify commands that are sent to it.

6. Wire to the first panel via RS-232, RS-422, or RS-485 connections to the Quantum™ LX Comm Port.
  - If you are communicating to more than one panel, then you will not be able to use RS-232. You can however, convert RS-232 to either RS-422 or RS-485 with an adapter card. Reference the *Converting an RS-232 Serial Port to RS-422 or RS-485* section for information about an adapter card.
  - Refer to the drawing of the *Quantum™ LX Main Board* in this manual to identify wiring and jumper locations for the Comm Ports.
  - Refer to the *Main Board Communications* section in this manual for the correct jumpering of RS-232, RS-422, or RS-485.
7. Send a single command to read data from this Quantum™ LX using its ID.
8. Check if you received a data response at your device.
9. Troubleshooting when you don't receive a data response:
  - Check to see if the status of the Comm Port on the **Communications** screen is showing *ACTIVE* or *OFF*.
  - *ACTIVE* is shown only when the Quantum™ LX understands it is receiving a properly composed message.
  - Check that the RX I/O communication activity lamp on the Quantum™ LX Main Processor Board is blinking as it receives the instruction from your device.
  - A steady lit RX LED or one that isn't lighting, are signs of improper wiring.
  - If the RX LED is properly blinking, then check if the TX LED is blinking in response.
  - If the TX is not blinking then check the communication protocol setup at the panel, the panel's ID and the Comm Port baud rate setting.
  - If the TX is blinking, then check that the Comm Port communication jumpers are correct.

**Note:** A useful tool for troubleshooting is Windows *HyperTerminal*. Refer to the *HyperTerminal Setup* section in this manual for more information.

If you properly receive data and need to communicate to more than one panel, then setup and wire to another panel. Reference the wiring diagram drawings in the back of this manual. Send a single command to read data from this Quantum™ LX using its ID and troubleshoot as above, if necessary. To prevent noise feedback which is possible when communicating over a long distance, only the last panel should have the termination jumpers installed.

## FRICK® PROTOCOL

### DESCRIPTION

All commands for Frick® protocols must be in ASCII to be recognized (see the *Conversion Chart For Decimal / Hexadecimal / ASCII*, located later in this manual). The commands can be in upper or lower case letters. A compressor with an ID code of [00] is considered disabled. ID codes from [01] through [99] are valid and recognized by the Quantum™.

### FRICK® # PROTOCOL SPECIFICATIONS

Frick # protocol consists of commands that are available for most other existing models of Frick compressor control panels. The Frick # protocol does not utilize a checksum. It is better to use Frick Quantum™ (\$) protocol when only communicating to Quantum™ 4A or Quantum™ LX panels.

When there is more than one panel, a Quantum™ LX can be wired from its communications ports to another panels' ports, or can be wired to Port 1 of a RWB, RDB, RXB or RXF Micro Plus panel.

Frick® RWB, RDB, RXB, or RXF Panel Frick® # Communications Port #1 RS-422 Pinout	
9	- TX (Transmit)
8	+ TX (Transmit)
5	- RX (Receive)
4	+ RX (Receive)

The following is a complete list of available Frick® Protocol # commands:

COMMAND CODE and DESCRIPTION	
I	= Returns compressor status (I)nfomation
R	= Compressor sta(R)t control
S	= Compressor (S)top control
A	= Return full load (A)mps information
V	= Slide (V)alve/Slide stop control
MC	= Change (M)ode of (C)ompressor
MV	= Change (M)ode of Slide (V)alve
P	= Return (P)ressures information
T	= Return (T)emperatures information
Q	= (Q)uery setpoints data
C	= Enter (C)hange setpoints mode
F	= Return (F)ailures
KF	= (K)Clear (F)ailures
KR	= (K)Clear remaining (R)ecycle delay time

All data is returned as integer values. If decimal positions are assumed, then divide the data by the proper multiple of 10 to get the actual value.

Temperature data, except for Suction Temperature, is returned in the current temperature units as 3 characters with no decimal position (i.e. 032 would represent 32 degrees Fahrenheit if the panel temperature units are in Fahrenheit, or it would represent 32 degrees Celsius, if the panel temperature units are in Celsius). Suction Temperature is returned as 4 characters with a + or - as the leading character (i.e. -010 would represent -10 degree).

Pressure data is usually returned in the current pressure units. However, the Filter differential reading is always returned in PSIA. When in PSIG or in PSIA, the pressure data is returned as 3 characters with no decimal position. However; in order to show the full transducer range, the #IDPS command returns 4 characters with one decimal position assumed. The #IDI, and #IDPA commands return 3 characters that assume one decimal position; therefore, 99.9 is the highest value that can be returned. When in PSIG, suction pressure is returned in PSIA. When in Bar and BarA, the pressure data is returned as 4 characters with two decimal positions assumed. When in KpaA, the pressure data is returned as 4 characters with no decimal position.

The following is a detailed description of each command:

RETURN COMPRESSOR STATUS INFO: #IDI	
<i>Command structure:</i>	
Command	Description
#	Start of command sequence
ID	Compressor (ID) code (01, 14, etc.)
I	Return Status (I)nfornation command
<b>Returned Answer, ie: 090RRRN340</b>	
Character Position	Description of returned data
1, 2, 3	Slide Valve position.
4	R = (R)emote
	A = (A)uto
	M = (M)anual (Slide Valve)
	D = (D)elay-recycle
	R = (R)unning
5	O = (O)ff
	S = (S)lide Valve too high
	P = (P)ermissive Start not enabled
	I = d(I)fferential Pressure too high
	T = s(T)opping
6	X = Au(X) not energized
	U = (U)nable to start
	R = (R)emote (Compressor mode)
7	M = Keypad
	A = (A)uto
	C = (C)utout (Shutdown)
8, 9, 10	A = (A)larm
	N = (N)ormal
8, 9, 10	Suction value in PSIA.
CR, LF (Carriage Return, Line Feed)	

**Note:** The following control commands are for remote control of a compressor. A compressor should be in both remote compressor mode and remote Slide Valve or capacity mode for remote control.

COMPRESSOR START CONTROL: #IDRID	
<i>Command structure:</i>	
Command	Description
#	Start command sequence
ID	Compressor (ID) code (01, 14, etc.)
R	Sta(R)t compressor command.
ID	(ID) code repeated for verification
<b>NOTE: The compressor must be in the remote Start Mode for this command to be executed.</b>	
<b>Returned answer:</b>	
Character Position	Description of returned data
1	(A)cknowledge
2, 3	(ID) code verified CR, LF (Carriage return, line feed)

COMPRESSOR STOP CONTROL: #IDSID	
<i>Command structure:</i>	
Command	Description
#	Start command sequence
ID	Compressor (ID) code (01, 14, etc.)
S	(S)top compressor command.
ID	(ID) code repeated for verification
<b>NOTE: The compressor must be in the remote Start mode for this command to be executed.</b>	
<b>Returned answer:</b>	
Character Position	Description of returned data
1	(A)cknowledge
2, 3	(ID) code verified CR, LF (Carriage return, line feed)

RETURN FULL LOAD AMPS COMMAND: #IDA	
<i>Command structure:</i>	
Command	Description
#	Start command sequence
ID	Compressor (ID) code (01, 14, etc.)
A	Return Full Load (A)mpps command
<b>Returned Answer:</b>	
When using the A command, the returned Full Load Amps will be:	
XXX = 3 characters followed by a CR, LF.	

<b>SLIDE VALVE CONTROL COMMANDS:</b>	<b>#IDVLXX</b> <b>#IDVS</b> <b>#IDVUXX</b>
--------------------------------------	--

*Command structure:*

Command	Description
#	Start command sequence
ID	Compressor (ID) code (01, 14, etc.)
V	Slide (V)alve / Slide Stop command
L	(L)oad Slide Valve command
U	(U)nload Slide Valve command
XX = 00	Turns selected output off
XX = 01 to 15	Turns selected output on for XX seconds
S	Return (S)lide Valve position value

If the command was #01VL00, then the load Slide Valve output on compressor #1 would be turned off. If the command was #01VL05, then the load Slide Valve output on compressor #1 would be turned on for 5 seconds, and would then automatically turn off. NOTE: the Slide Valve must be in the remote mode for this command to be executed. Time is not accrued, each command restarts timer.

**Returned Answer (for L or U commands):**

Character Position	Description of returned data
1	(A)cknowledge
2, 3	(ID) code verified (Carriage return, line feed.)

**Returned Answer (for S command):**

Character Position	Description of returned data
1, 2, 3	Slide Valve position. CR, LF (Carriage return, line feed)

<b>RETURN SLIDE STOP POSITION COMMAND:</b>	<b>#IDVP</b>
--	--------------

*Command structure:*

Command	Description
#	Start command sequence
ID	Compressor (ID) code (01, 14, etc.)
V	Slide (V)alve / Slide Stop command
P	Return Slide Stop (P)osition value

**Returned Answer:**

Character Position	Description of returned data
1, 2	Slide Stop position, i.e. 25 = 2.5 CR, LF (Carriage return, line feed)

<b>CHANGE COMPRESSOR MODE COMMAND:</b>	<b>#IDMCmID</b>
--	-----------------

*Command structure:*

Command	Description
#	Start command sequence
ID	Compressor (ID) code (01, 14, etc.)
MC	Change (M)ode of (C)ompressor
= O	(O)ff
m = A	(A)uto
= R	(R)emote
ID	(ID) code repeated for verification

**Returned Answer:**

Character Position	Description
1	(A)cknowledge
2, 3	(ID) code verified (Carriage return, line feed)

**CHANGE SLIDE VALVE MODE COMMAND: #IDMVmID**

*Command structure:*

Command	Description
#	Start command sequence
ID	Compressor (ID) code (01, 14, etc.)
MV	(M)ode of Compressor Slide (V)alve
= O	(O)ff
m = A	(A)uto
= R	(R)emote
ID	(ID) code repeated for verification

---

**Returned Answer:**

Character Position	Description
1	(A)cknowledge
2, 3	(ID) code verified (Carriage return, line feed)

**RETURN PRESSURES COMMAND: #IDPX**

*Command structure:*

Command	Description
#	Start command sequence
ID	Compressor (ID) code (01, 14, etc.)
P	Return (P)ressures command
= S	Return (S)uction Pressure (PSIA)
= D	Return (D)ischarge Pressure (g/hg)
X = O	Return (O)il Pressure (g)
= F	Return (F)ilter differential Pressure
= A	Return (A)ll pressures as a string of data

*Command Examples: (Compressor #01 is used here)*

- #01PS Returns the Suction Pressure
- #01PD Returns the Discharge Pressure
- #01PO Returns the Oil Pressure
- #01PF Returns the Filter Differential Pressure
- #01PA Returns All pressures

**Note: Don't send CR or LF**

---

**Returned Answer:**

If using the **S** command the returned pressure will be:  
XXXX = 4 characters followed by a CR, LF.

If using the **D**, **O** or **F** commands, the returned pressure will be:  
XXX = 3 characters followed by a CR, LF.

If using the **A** command, the returned data would be:  
XXXXXXXXXXXX = 12 characters followed by a CR, LF.

**RETURN TEMPERATURES COMMAND: #IDTX**

*Command structure:*

Command	Description
#	Start command sequence
ID	Compressor (ID) code (01, 14, etc.)
T	Return (T)emperature command
= S	Return (S)uction Temperature
= D	Return (D)ischarge Temperature
X = O	Return (O)il Temperature
= P	Return Se(P)arator Temperature
= A	Return (A)ll temps as a string of data

*Command Examples: (Compressor #01 is used here)*

- #01TS Returns the Suction Temperature
- #01TD Returns the Discharge Temperature
- #01TO Returns the Oil Temperature
- #01TP Returns the Separator Temperature
- #01TA Returns All Temperatures

**Note: Don't send CR or LF**

---

**Returned Answer:**

If using the **S** command the returned temp. will be:  
+/-XXX = The first character will be a + or -, followed by 3 characters and ending with a CR, LF.

If using the **D**, **O** or **P** commands, the returned temp. will be:  
XXX = 3 characters followed by a CR, LF.

If using the **A** command, the returned data would be:  
XXXXXXXXXXXX = 12 characters followed by a CR, LF.

QUERY SETPOINTS DATA:		#IDQ1
<i>Command structure:</i>		
Command	Description	
#	Start command sequence	
ID	Compressor (ID) code (01, 14, etc.)	
Q1	(Q)uery Setpoints command	
<b>Returned Answer:</b>		
Character Position	# Byte(s)	Setpoint (Name/Comment)
1	1	Always 0
2, 3, 4, 5	4	Capacity Control Setpoint, 3 chars followed by g or h
14, 15	2	Prop band
16, 17	2	Dead band
18, 19	2	Cycle time
20, 21, 22, 23	4	Future
24, 25, 26, 27	4	Future
28, 29, 30, 31	4	Future
32, 33	2	Future
34, 35	2	Future
36, 37	2	Future
38, 39, 40, 41	4	High Discharge Pressure Shutdown
42, 43, 44, 45	4	High Discharge Pressure Warning
46	1	ID (tenths position byte)
47	1	ID (ones position byte)
48	1	ID Checksum of all data (pos. 1 to 47)
49	1	CR code 13
50	1	LF code 10
51	1	0 null terminator char.

QUERY SETPOINTS DATA:		#IDQ2
<i>Command structure:</i>		
Command	Description	
#	Start command sequence	
ID	Compressor (ID) code (01, 14, etc.)	
Q2	(Q)uery Setpoints command	
<b>Returned Answer:</b>		
Character Position	# Byte(s)	Setpoint (Name/Comment)
1, 2, 3	3	Future
4, 5, 6	3	Future
7, 8, 9	3	MLC amps stop load
10, 11, 12	3	MLC amps force unload
13, 14, 15	3	CT factor
16, 17	2	Recycle delay (setpoint, not time left)
18	1	Aux 1
19	1	Aux 1
20	1	Aux 2
21	1	Aux 2
22	1	Future
23, 24	2	Future
25	1	Future
26	1	Future
27, 28	2	Future
29	1	Future
30	1	ID (tenths position byte)
31	1	ID (ones position byte)
32	1	ID Checksum of all data (pos. 1 to 47)
33	1	CR code 13
34	1	LF code 10
35	1	0 null terminator char.



RETURN FAILURE COMMAND:		#IDF
<i>Command structure:</i>		
Command	Description	
#	Start command sequence	
ID	Compressor (ID) code (01, 14, etc.)	
F	Return Discrete (F)ailures List	
<b>Returned Answer:</b>		
Character Position	Alarm Description	
1	High Discharge Pressure Shutdown	0 = Safe 1 = Shutdown
2	High Discharge Pressure Warning	0 = Safe 1 = Warning
3	Low Suction Pressure Shutdown	0 = Safe 1 = Shutdown
4	Low Suction Pressure Warning	0 = Safe 1 = Warning
5	Low Oil Pressure Shutdown and/or Differential Oil Pressure Shutdown	0 = Safe 1 = Shutdown
6	Low Oil Pressure Warning	0 = Safe 1 = Warning
7	High Oil Temperature Shutdown	0 = Safe 1 = Shutdown
8	High Oil Temperature Warning	0 = Safe 1 = Warning
9	Low Oil Temperature Shutdown	0 = Safe 1 = Shutdown
10	Low Oil Temperature Warning	0 = Safe 1 = Warning
11	High Discharge Temperature Shutdown	0 = Safe 1 = Shutdown
12	High Discharge Temperature Warning	0 = Safe 1 = Warning
13	Compressor Aux. Fail- Shutdown	0 = Safe 1 = Shutdown
14	Pump Aux. Fail- Shutdown	0 = Safe 1 = Shutdown
15	Oil Level Shutdown	0 = Safe 1 = Shutdown
16	Unused - 0	
17	High Oil Filter Pressure Warning	0 = Safe 1 = Warning
18	Unused - 0	
19	Auxiliary 1 Alarm/Shutdown	0 = Safe 1 = Shutdown
20	Auxiliary 2 Alarm/Shutdown	0 = Safe 1 = Shutdown
21	Low Motor Current - Shutdown	0 = Safe 1 = Shutdown
22	Sensor Fault	0 = Safe 1 = Warning
23	Unused - 0	
24	Unused - 0	

CLEAR FAILURE COMMAND:		#IDKFID
<i>Command structure:</i>		
Command	Description	
#	Start command sequence	
ID	Compressor (ID) code (01, 14, etc.)	
KF	(K)Clear (F)ailures	
ID	(ID) code repeated for verification	

Returned Answer:	
Character Position	Description
1	(A)cknowledge
2, 3	(ID) code verified (Carriage return, line feed)

CLEAR ANTIRECYCLE COMMAND:		#IDKRID
<i>Command structure:</i>		
Command	Description	
#	Start command sequence	
ID	Compressor (ID) code (01, 14, etc.)	
KR	(K)Clear (R)ecycle Delay	
ID	(ID) code repeated for verification	

Returned Answer:	
Character Position	Description
1	(A)cknowledge
2, 3	(ID) code verified (Carriage return, line feed)

**NOTE:** Returns a 24 char data string followed by ID, CR, LF.

**QUANTUM™ \$ PROTOCOL SPECIFICATIONS**

Quantum™ (\$) protocol commands are used by both the Quantum™ and the Quantum™ LX. This protocol has been modified slightly for the LX, in that the *D* command has been eliminated, and the addressing structure has changed. Any previously configured Quantum™ LX protocol applications that had been written for Quantum™ panels, will still work for the LX, by using the Map File on the *Communications Screen*.

Unless otherwise shown, 9 characters are returned from the Quantum™ for a data value. The data value includes two decimal fields and the first character position is either; - if the value is negative, or it is + if the value is positive. For example, if the data's value is 25.5; then the value +00002550 is sent. All temperatures are in degree C and all pressures are in PSIA. A mode such as Slide Valve mode is returned as an integer value that represents the mode that it is in. For example, a +00000000 is sent if it is in manual, or a +00000100 is sent if it is in automatic, or a +00000200 is sent if it is in remote. The value zero +00000000 is used to represent an OFF status and a DISABLED option. The value one +00000100, which is received as a 1, is used to represent an ON status and an ENABLED option. Setpoints are only changed if the value sent is within the acceptable range. Reference the *Frick® Quantum™ Control Panel Maintenance* publication S90-020 M for the setpoints default settings and ranges. The checksum is the 2 byte hexadecimal sum of each character within the command or returned answer excluding the command type identifier, \$. If the command's checksum is replaced with ??, the Quantum™ returns a response without using checksum error checking on the received command (refer to the *Data Packet* section for more information). If the Quantum™ detects a checksum error, a *N* (Not Acknowledged), the Compressor ID code, *O2*, Carriage return, and Linefeed are returned.

This document will demonstrate how to communicate to the Quantum™ panel using the tables that appear on the following pages.

**Data Packet**

If you were interested in viewing the information that is contained in any of the accessible Quantum™ addresses, you would want to refer to the table entitled *RETURN DATA VALUE FROM TABLE \$IDT1* table later in this section.

The quickest and easiest way to demonstrate this protocol is through Hyperterminal (see the section entitled *Hyperterminal* later in this manual). After setting up Hyperterminal and ensuring that all wiring and jumper configurations are correct, type a \$ symbol. This is the character that will alert all of the Quantum™ panels on the communications line that data is on its way. Following the \$ symbol, type the ID code of the Quantum™ that you wish to query (for

instance *O1* for the first Quantum™). After the ID number, type a *T1*. The protocol code in the Quantum™ recognizes this portion of the data packet as a request for the data from a memory location (address).

Up to now you have typed the following information: *\$O1T1*. Now you to need specify the address(s) that you wish to query. Up to sixteen addresses may simultaneously be requested. The format for this entry must be in the form of four digits, so if you want to query the Frick address for Suction Pressure (address 2002), simply enter the value 2002. Your command line should now look like this: *\$O1T12002*. If you would like to view additional addresses, simply continue to append the address numbers to this command (up to sixteen total). For this example, we will only use the one address (2002 for Suction Pressure). The next thing that must be done is to enter a checksum value. You may elect to type in a ?? as a wildcard if you do not have the time to figure the correct checksum, however, the information that is returned may or may not always be reliable. The checksum will ensure reliability.

To arrive at the checksum value for the command you have just typed, you will need to convert each ASCII digit into hexadecimal (do not include the \$ symbol). For this example, you will need to take the first digit *O*, and referring to the Conversion Chart at the end of this section, look down the ASCII column until you find *O*. You will notice that the Hexadecimal equivalent for ASCII *O* is *30* hex. Repeat the process of looking up each digit in the ASCII column, and finding its equivalent in the Hexadecimal column, and write each value down. When all eight (minimum) digits (*O1T12002*) have been converted to hexadecimal, you will need to add the eight values together. Remember, the values are in hexadecimal format, not decimal. If you are not familiar with hexadecimal math, you may wish to utilize the calculator that comes with Microsoft Windows. Look at the following chart:

ASCII Value of Data Packet	Hexadecimal Equivalent
0	30
1	31
T	54
1	31
2	32
0	30
0	30
2	32
Hex Total	= 1AA

The answer that is arrived at from the previous chart is *1A8*.

**NOTE:** For any calculation that results in an answer of more than two digits, use only the right most two digits, and disregard all digits to the left.

This will become the checksum for the data packet, and is appended to the end of the data that has so far been typed in.

The result should look like this:

\$01T12002A8

Press the **[Enter]** key. You should see an immediate response. The format of this response should resemble something (but not necessarily exactly) like:

A01+00006166B6

Referring to the *RETURN DATA VALUE FROM TABLE \$IDT1* table on the next page, we find that the first line of the response, *A01*, indicates that an Acknowledgement (A) was received from device 01 (01). This is followed by *+00006166* (Suction Pressure). The plus (+) symbol indicates a positive value, followed by *00006166*. Since there are two decimal positions assumed, *0006166* equals 61.66 PSIA. Using the +/- symbols as a delimiter in the above example, each section of 8 digits can be interpreted as the actual value being returned from each of the address queries. The *B6* value at the very end of the response is the checksum value that the Quantum™ returned, not actual data.

The following is a complete list of available \$ command types:

**COMMAND CODE and DESCRIPTION**

- CA = Clear Alarms
- CL = Compressor load
- CP = Compressor stop
- CS = Change a setpoint in the Table
- CT = Compressor Start
- CU = Compressor unload
- D1 = Operating Status Display Page 1
- D2 = Operating Status Display Page 2
- D3 = Operating Status Display Page 3
- D4 = Operating Status Display Page 4
- F1 = Warnings/Shutdowns Annunciation Page 1
- F2 = Warnings/Shutdowns Annunciation Page 2
- F3 = Warnings/Shutdowns Annunciation Page 3
- MA = Compressor mode – Autocycle
- MM = Compressor mode – Manual
- MR = Compressor mode – Remote
- S2 = Compressor sequence – activate
- S3 = Compressor sequence – de-activate
- T1 = Read a value from the Table
- VA = Slide Valve mode – Automatic
- VR = Slide Valve mode – Remote

The following is a detailed description of each command:

**CLEAR ALARMS COMMAND: \$IDCA**

*Command structure:*

Command	Description
\$	Start command sequence
ID	Compressor (ID) code (01, 14, etc.)
CA	(C)lear (A)larms
CS	Checksum
CR	Carriage Return

**Returned Answer:**

Character Position	Description of returned data
1	(A)cknowledge
2, 3	(ID) code verified
	Carriage Return, Line Feed

**SLIDE VALVE CONTROL COMMANDS: \$IDCLXX**

*Command structure:*

Command	Description
\$	Start command sequence
ID	Compressor (ID) code (01, 14, etc.)
C	Slide Valve/Slide Stop (C)ommand
L	(L)oad Slide Valve command
U	(U)nload Slide Valve Command
XX = 00	Turns selected output off.
XX=01 to 15	Turns selected output on for XX seconds.
CS	Checksum
CR	Carriage Return

If the command is \$01CL00, then the load Slide Valve output on compressor #1 would be turned off. Time is not accrued, each command restarts timer. **NOTE: the Slide Valve must be in the remote mode for this command to be executed.**

**Returned Answer (for L or U commands):**

Character Position	Description of returned data
1	(A)cknowledge
2, 3	(ID) code verified
	Carriage Return, Line Feed

<b>COMPRESSOR STOP COMMAND:                    \$IDCP</b>	
<i>Command structure:</i>	
Command	Description
\$	Start command sequence
ID	Compressor (ID) code (01, 14, etc.)
CP	(C)ompressor (S)top
CS	Checksum
CR	Carriage Return
<b>Returned Answer:</b>	
Character Position	Description of returned data
1	(A)cknowledge
2, 3	(ID) code verified Carriage Return, Line Feed

<b>COMPRESSOR START COMMAND:                    \$IDCT</b>	
<i>Command structure:</i>	
Command	Description
\$	Start command sequence
ID	Compressor (ID) code (01, 14, etc.)
CT	(C)ompressor S(T)art
CS	Checksum
CR	Carriage Return
<b>Returned Answer:</b>	
Character Position	Description of returned data
1	(A)cknowledge
2, 3	(ID) code verified Carriage Return, Line Feed

<b>CHANGE SETPOINT COMMAND:                    \$IDCS</b>	
<i>Command structure:</i>	
Command	Description
\$	Start of command sequence
ID	Compressor (ID) code
CS	(C)hange (S)etpoint in Table address
0000	Frick®'s Table address of the setpoint
+/-	Polarity indicator (for the new setpoint)
0000 0000	Value of the new setpoint. Decimal point assumed to two places (0000 00.00)
CS	Checksum
CR	Carriage Return
<b>Returned Answer:</b>	
Character Position	Description of returned data
1	(A)cknowledge
2, 3	(ID) code verified Carriage Return, Line Feed

<b>SLIDE VALVE CONTROL COMMANDS:                    \$IDCUXX</b>	
<i>Command structure:</i>	
Command	Description
\$	Start command sequence
ID	Compressor (ID) code (01, 14, etc.)
C	Slide Valve/Slide Stop (C)ommand
U	(U)nload Slide Valve command
XX = 00	Turns selected output off
XX=01 to 15	Turns selected output on for XX seconds
CS	Checksum
CR	Carriage Return
If the command is \$01CU05, then the load Slide Valve output on compressor #1 would be turned on for 5 seconds, and would then automatically turn off. Time is not accrued, each command restarts timer. <b>NOTE: the Slide Valve must be in the remote mode for this command to be executed.</b>	
<b>RETURNED ANSWER (for L or U commands): A01</b>	
Character Position	Description of returned data
1	(A)cknowledge
2, 3	(ID) code verified Carriage Return, Line Feed

RETURN OPERATING STATUS – Page 1 Data:		\$IDD1
<i>Command structure:</i>		
Command	Description	
\$	Start of command sequence.	
ID	Compressor (ID) code (01, 14, etc.)	
D1	Operating Status (D)ata – Page (1) command.	
CS	Checksum	
CR	Carriage Return	

RETURNED ANSWER,	
Character Position	Description of returned data
1	(A)cknowledge
2, 3	(ID) code verified
4-12	Suction Pressure
13-21	Suction Temperature
22-30	Discharge Pressure
31-39	Discharge Temperature
40-49	Oil Pressure
49-57	Oil Temperature
58-66	Filter Differential
67-75	Motor Current
76-84	FLA%
85-93	Kilowatts
94-102	Slide Valve
103-111	Slide Stop
112-120	Process Temperature
121, 122	Checksum, Carriage Return, Line Feed if successful

RETURN OPERATING STATUS – Page 2 Data:		\$IDD2
<i>Command structure:</i>		
Command	Description	
\$	Start of command sequence.	
ID	Compressor (ID) code (01, 14, etc.)	
D2	Operating Status (D)ata – Page (2) command.	
CS	Checksum	
CR	Carriage Return	

RETURNED ANSWER,	
Character Position	Description of returned data
1	(A)cknowledge
2, 3	(ID) code verified
4-12	Alarm Status
13-21	Shutdown Status
22-30	Running Status
31-39	Slide Valve Load
40-49	Slide Valve Unload
49-57	Slide Stop Increase
58-66	Slide Stop Decrease
67-75	Stop Load/Force Unload Code
76-84	Separator Temperature
85-93	Balance Piston Pressure
94-102	Process Variable
103-111	Compressor Mode
112, 113	Checksum, Carriage Return, Line Feed if successful

<b>RETURN OPERATING STATUS –</b>		<b>\$IDD3</b>
<b>Page 3 Data:</b>		
<i>Command structure:</i>		
Command	Description	
\$	Start of command sequence	
ID	Compressor (ID) code (01, 14, etc.)	
D3	Operating Status (D)ata – Page (3) command	
CS	Checksum	
CR	Carriage Return	
<b>RETURNED ANSWER,</b>		
Character Position	Description of returned data	
1	(A)cknowledge	
2, 3	(ID) code	
4-12	Communication Port 1 Code	
13-21	Communication Port 2 Code	
22-30	I/O Communication Port Code	
31-39	Capacity Control Mode	
40-48	Process Control	
49-57	Oil Pump Mode	
58-66	Oil Pump Code	
67-75	Oil Heater Code	
76-84	Process Setpoint	
85-93	Slide Valve Mode	
94-102	Slide Stop Mode	
103-111	Runtime Hours	
112, 113	Checksum, Carriage Return, Line Feed if successful	

<b>RETURN OPERATING STATUS –</b>		<b>\$IDD4</b>
<b>Page 4 Data:</b>		
<i>Command structure:</i>		
Command	Description	
\$	Start of command sequence	
ID	Compressor (ID) code (01, 14, etc.)	
D4	Operating Status (D)ata – Page (4) command	
CS	Checksum	
CR	Carriage Return	
<b>RETURNED ANSWER,</b>		
Character Position	Description of returned data	
1	(A)cknowledge	
2, 3	(ID) code.	
4-12	Date as 00/00/00	
13-22	Time as hh:mm:ss	
23-29	Remaining Recycle time as mm:ss	

30, 31	Checksum, Carriage Return, Line Feed if successful	
<b>RETURN Alarms &amp; Shutdowns –</b>		<b>\$IDF1</b>
<b>Page 1 Data:</b>		
<i>Command structure:</i>		
Command	Description	
\$	Start of command sequence	
ID	Compressor (ID) code (01, 14, etc.)	
F1	(F)ailure Annunciation command Page (1)	
CS	Checksum	
CR	Carriage Return	
<b>RETURNED ANSWER,</b>		
Character Position	Description of returned data	
1	(A)cknowledge	
2, 3	(ID) code	
4-6	Message Code 1	
7-14	Date 1 as mm/dd/yy	
15-22	Time 1 as hh:mm:ss	
23	Space	
24-26	Message Code 2	
27-34	Date 2 as mm/dd/yy	
35-42	Time 2 as hh:mm:ss	
43	Space	
44-46	Message Code 3	
47-54	Date 3 as mm/dd/yy	
55-62	Time 3 as hh:mm:ss	
63	Space	
64-66	Message Code 4	
67-74	Date 4 as mm/dd/yy	
75-82	Time 4 as hh:mm:ss	
83	Space	
84-86	Message Code 5	
87-94	Date 5 as mm/dd/yy	
95-102	Time 5 as hh:mm:ss	
103	Space	
104-106	Message Code 6	
107-114	Date 6 as mm/dd/yy	
115-122	Time 6 as hh:mm:ss	
123	Space	
124-125	Checksum, Carriage Return, Line Feed if successful	

RETURN Alarms & Shutdowns – Page 2 Data:		\$IDF2
<i>Command structure:</i>		
Command	Description	
\$	Start of command sequence	
ID	Compressor (ID) code (01, 14, etc.)	
F2	(F)ailure Annunciation command Page (2)	
CS	Checksum	
CR	Carriage Return	

RETURNED ANSWER,	
Character Position	Description of returned data
1	(A)cknowledge
2, 3	(ID) code.
4-6	Message Code 7
7-14	Date 7 as mm/dd/yy
15-22	Time 7 as hh:mm:ss
23	Space
24-26	Message Code 8
27-34	Date 8 as mm/dd/yy
35-42	Time 8 as hh:mm:ss
43	Space
44-46	Message Code 9
47-54	Date 9 as mm/dd/yy
55-62	Time 9 as hh:mm:ss
63	Space
64-66	Message Code 10
67-74	Date 10 as mm/dd/yy
75-82	Time 10 as hh:mm:ss
83	Space
84-86	Message Code 11
87-94	Date 11 as mm/dd/yy
95-102	Time 11 as hh:mm:ss
103	Space
104-106	Message Code 12
107-114	Date 12 as mm/dd/yy
115-122	Time 12 as hh:mm:ss
123	Space
124, 125	Checksum, Carriage Return, Line Feed if successful

RETURN Alarms & Shutdowns – Page 3 Data:		\$IDF3
<i>Command structure:</i>		
Command	Description	
\$	Start of command sequence.	
ID	Compressor (ID) code (01, 14, etc.)	
F3	(F)ailure Annunciation command Page (3)	
CS	Checksum	
CR	Carriage Return	

RETURNED ANSWER,	
Character Position	Description of returned data
1	(A)cknowledge
2, 3	(ID) code.
4-6	Message Code 13
7-14	Date 13 as mm/dd/yy
15-22	Time 13 as hh:mm:ss
23	Space
24-26	Message Code 14
27-34	Date 14 as mm/dd/yy
35-42	Time 14 as hh:mm:ss
43	Space
44-46	Message Code 15
47-54	Date 15 as mm/dd/yy
55-62	Time 15 as hh:mm:ss
63	Space
64-66	Message Code 16
67-74	Date 16 as mm/dd/yy
75-82	Time 16 as hh:mm:ss
83	Space
84-86	Message Code 17
87-94	Date 17 as mm/dd/yy
95-102	Time 17 as hh:mm:ss
103	Space
104-106	Message Code 18
107-114	Date 18 as mm/dd/yy
115-122	Time 18 as hh:mm:ss
123	Space
124, 125	Checksum, Carriage Return, Line Feed if successful

**RETURN Data Value From Table: \$IDT1**

*Command structure:*

Command	Description
\$	Start of command sequence.
ID	Compressor (ID) code (01, 14, etc.)
T1	Return the value of a Table address. Frick® Address (s) of data value in Table. Up to 16 different addresses can be requested.
0000 0000	
0000 0000	
0000 0000	Example # 1: if requesting Suction Temperature only, command would be (to compressor ID of 1); \$01T10128CSCR.
0000 0000	
0000 0000	Example # 2: If requesting address 128 through 136, the command would be \$01T1012801290130013101320133013401350136CSCR.
0000 0000	
0000 0000	
CS	Checksum
CR	Carriage Return

**RETURNED ANSWER,**

Character Position	Description of returned data
1	(A)cknowledge
2, 3	(ID) code. Value(s) of requested data. CS (Checksum followed by CR, LF) if successful
4-End	The response to example # 1 above would look like: <b>A01+000018731F</b> , the plus symbol (+) indicates that the data value returned is positive.  The response to example # 2 above would look like: <b>A01+00001873+00004901+00002949+00005652-0027249+00008211+00013354+00000656+0000288109</b>

**NOTE:** The following commands are for remote control of a compressor. A compressor should be in both remote compressor mode and remote Slide Valve or capacity mode for remote control.

**COMPRESSOR MODE – AUTOCYCLE COMMAND: \$IDMA**

*Command structure:*

Command	Description
\$	Start of command sequence.
ID	Compressor (ID) code (01, 14, etc.)
MA	(M)ode (A)utocycle
CS	Checksum
CR	Carriage Return

**RETURNED ANSWER,**

Character Position	Description of returned data
1	(A)cknowledge
2, 3	(ID) code. Carriage Return, Line Feed if successful

**COMPRESSOR MODE – MANUAL COMMAND: \$IDMM**

*Command structure:*

Command	Description
\$	Start of command sequence.
ID	Compressor (ID) code (01, 14, etc.)
MM	(M)annual (M)ode
CS	Checksum
CR	Carriage Return

**RETURNED ANSWER,**

Character Position	Description of returned data
1	(A)cknowledge
2, 3	(ID) code. Carriage Return, Line Feed if successful

<b>COMPRESSOR MODE – REMOTE COMMAND:</b>		<b>\$IDMR</b>
<i>Command structure:</i>		
Command	Description	
\$	Start of command sequence.	
ID	Compressor (ID) code (01, 14, etc.)	
MR	(M)ode (R)emote	
CS	Checksum	
CR	Carriage Return	
<b>RETURNED ANSWER,</b>		
Character Position	Description of returned data	
1	(A)cknowledge	
2, 3	(ID) code. Carriage Return, Line Feed if successful	

<b>SLIDE VALVE MODE – AUTOMATIC COMMAND:</b>		<b>\$IDVA</b>
<i>Command structure:</i>		
Command	Description	
\$	Start of command sequence.	
ID	Compressor (ID) code (01, 14, etc.)	
VA	Slide (V)alve Mode (A)utomatic	
CS	Checksum	
CR	Carriage Return	
<b>RETURNED ANSWER,</b>		
Character Position	Description of returned data	
1	(A)cknowledge	
2, 3	(ID) code. Carriage Return, Line Feed if successful	

<b>COMPRESSOR SEQUENCE – ACTIVATE COMMAND:</b>		<b>\$IDS2</b>
<i>Command structure:</i>		
Command	Description	
\$	Start of command sequence.	
ID	Compressor (ID) code (01, 14, etc.)	
S2	(S)equence Activate (2)	
CS	Checksum	
CR	Carriage Return	
<b>RETURNED ANSWER,</b>		
Character Position	Description of returned data	
1	(A)cknowledge	
2, 3	(ID) code. Carriage Return, Line Feed if successful	

<b>SLIDE VALVE MODE – REMOTE COMMAND:</b>		<b>\$IDVR</b>
<i>Command structure:</i>		
Command	Description	
\$	Start of command sequence.	
ID	Compressor (ID) code (01, 14, etc.)	
VR	Slide (V)alve Mode (R)emote	
CS	Checksum	
CR	Carriage Return	
<b>RETURNED ANSWER,</b>		
Character Position	Description of returned data	
1	(A)cknowledge	
2, 3	(ID) code. Carriage Return, Line Feed if successful	

<b>COMPRESSOR SEQUENCE – DE-ACTIVATE COMMAND:</b>		<b>\$IDS3</b>
<i>Command structure:</i>		
Command	Description	
\$	Start of command sequence.	
ID	Compressor (ID) code (01, 14, etc.)	
S3	(S)equence Activate (3)	
CS	Checksum	
CR	Carriage Return	
<b>RETURNED ANSWER,</b>		
Character Position	Description of returned data	
1	(A)cknowledge	
2, 3	(ID) code. Carriage Return, Line Feed if successful	

## QUANTUM™ LX ALLEN-BRADLEY COMMUNICATION

This section contains programming examples for reading data from and writing data to the Frick Quantum control panel from an Allen Bradley (AB) SLC500 or PLC5 processor. Allen Bradley (AB) RSLogix500 programming software has been used for the following examples, however, these examples can also be used for the AB RSLogix5 software.

### Overview Of Half And Full Duplex Theory

To provide for the reading and writing of data to Quantum™ LX panels using Allen-Bradley communication, the Quantum™ LX has an Allen-Bradley DF1 communication driver that recognizes either half or full duplex SLC 500 protected typed logical read and write commands (either half or full duplex must be selected). Half-duplex simply means that data can only be sent in one direction at a time (the concept of how a walkie-talkie works). Using full-duplex, data can be sent and received simultaneously (the concept of how a telephone works). This is a Master / Slave multi-drop communication method.

The Quantum™ LX talks Allen-Bradley SLC protocol and is programmed to resemble an Allen-Bradley SLC500 slave station. The customer's PLC or DCS must be setup to initiate the reading and writing of data to a Quantum™ LX. The Quantum™ LX does not initiate any communications. The panel ID number is used as its station address and the target node. With the AB PLC, the MSG (Message) instruction is used to send read and write requests. A DCS (Distributed Control System) will use a SLC 500 DF1 protocol driver to send protected typed logical read with 3 address fields and protected typed logical write requests with 3 address fields to a Quantum™ LX. Fifty (50) data elements can be read with one read.

Setpoints are changed by sending a write command to one element. Changing a setpoint causes the Quantum™ LX to save the new setpoint to Flash memory (non-volatile memory).

**Be careful not to continuously request a setpoint change. It is to be expected that communications may slow down during the process of writing setpoints or clearing alarms. Both of these processes involve writing to either EEPROM or Flash Memory and does take some time. If communication requests are being sent faster than once every couple of seconds, there will be temporary slowdowns during these processes.**

Additionally, keeping the Quantum™ LX busy writing to Flash memory will interfere with the communications to its I/O Boards. A

communication failure to an I/O board will cause the compressor to shutdown. Control commands such as starting the compressor are also sent with a write command. For more detail and a list of the data, reference the *Quantum™ LX Data Table* section. For details about the actual protocol, reference the AB publication 1770-6.5.16 *DF1 Protocol and Command Set Reference Manual*.

Because overrun can occur, the baud rate and commands should be setup to produce the most desired throughput. The master station should have the Stop Bit and Parity set to match the Quantum™ LX, Duplicate Detect disabled, and Error Detect set for BCC or CRC.

When communication is between either your programming software and a Quantum™ LX or an Allen-Bradley PLC and a Quantum™ LX on a multi-drop link, the devices depend on a DF1 Master to give each of them polling permission to transmit in a timely manner. As the number of Quantum™ LX slaves increase on the link, the time between when each panel is polled also increases. This increase in time may become larger if you are using low baud rates. As these time periods grow, the timeouts such as the message timeout, poll timeout and reply timeout may need to be changed to avoid loss of communication.

**ACK Timeout** - The amount of time in 20 milliseconds increments that you want the processor to wait for an acknowledgment to the message it has sent before the processor retries the message or the message errors out.

**Reply Message Wait Time** - Define the amount of time in 20 millisecond increments that the master station will wait after receiving an ACK (to a master-initiate message) before polling the remote station for a reply. Choose a time that is, at minimum, equal to the longest time that a remote station needs to format a reply packet. Some remote stations can format reply packets faster than others.

**Message Timeout** - Defines the amount of time in seconds that the message will wait for a reply. If this time elapses without a reply, the error bit is set, indicating that the instruction timed out. A timeout of 0 seconds means that there is no timer and the message will wait indefinitely for a reply. Valid range 0-255 seconds.

**Note:** Make sure the Allen-Bradley PLC and the programming software is the most recent software revision. Some revisions have been made that do not allow the SLC Typed Logical Read/Write Message Command.

## SLC-500 - Suggested Setup

The following are representations of the channel configuration screens from the AB RSLogix500 programming software for the SLC500. Enter values as shown in order to establish communications via AB Protocol.

### CHANNEL CONFIGURATION

Configure the communication channel - Channel 0:  
Current Communication Mode: System  
Communication Driver: DF1 Half-Duplex Master or DF1 Full-Duplex  
Baud Rate: 19200 (suggested)  
Stop Bits: 1 (suggested)  
Duplicate Detect: Disabled  
ACK Timeout (x20ms): 30  
Message Retries: 3  
Parity: None (suggested)  
Station Address (Source ID): 5 (Master's DF1 selected ID#)  
Error Detect: BCC / CRC  
RTS off Delay (x20ms): 0  
RTS Send Delay (x20ms): 0  
Pre-Send Time Delay (x1 ms): 0  
Control Line: No Handshaking  
Polling Mode: Message Based (do not allow slave to initiate messages)  
Priority Polling Range - Low: 255, High: 0  
Normal Polling Range - Low: 255, High: 0  
Normal Poll Group Size: 0  
Reply Message Wait Time (x20ms): 20  
System Mode Driver: DF1 Half-Duplex Master or DF1 Full-Duplex  
User Mode Driver: Generic ASCII  
Write Protect: DISABLED  
Mode Changes: DISABLED  
Mode Attention Character: \0x1b (default)  
System Mode Character: S (default)  
User Mode Character: U (default)  
Edit Resource/File Owner Timeout (Sec): 60  
Passthru Link ID (decimal): 1

### READ MESSAGE SETUP EXAMPLE

Read/Write Message  
Type: Peer-To-Peer  
Read/Write: Read  
Target Device: 500 CPU  
Local/Remote: Local  
Control Block: N11:0  
Control Block Length: 14  
Channel: 0  
Target Node: 2 (002) (this is the Quantum™ Panel ID)  
Local File Address: N12:0  
Target File Address/Offset: N10:0  
Message Length in Elements: 50  
Message Time-out (seconds): 15

(Refer to the *Allen-Bradley Programming Overview* Section for more information)

### WRITE MESSAGE SETUP EXAMPLE

Read/Write Message  
Type: Peer-To-Peer  
Read/Write: Write  
Target Device: 500 CPU  
Local/Remote: Local  
Control Block: N11:0  
Control Block Length: 14  
Channel: 0  
Target Node: 2 (002) (this is the Quantum™ LX Panel ID)  
Local File Address: N12:0  
Target File Address/Offset: N55:3  
Message Length in Elements: 1  
Message Time-out (seconds): 15

Enter 20 into N12:0 to send the command to set the compressor in remote mode.

(Refer to the *Allen-Bradley Programming Overview* Section for more information)

## ALLEN-BRADLEY PROGRAMMING OVERVIEW

This section contains programming examples for reading data from, and writing data to the Frick® Quantum™ LX control panel from an Allen Bradley (AB) SLC500 processor. AB RSLogix500 programming software has been used for the following examples, however, these examples can also be used for the AB RSLogix5 software.

## CHANNEL CONFIGURATION

The following are representations of the channel configuration screens from the AB RSLogix500 programming software for the SLC500. Enter values as shown in order to establish communications via AB Protocol.

### General Configuration

**Channel Configuration**

General | Chan. 1 - System | Chan. 0 - System | Chan. 0 - User

Channel 1

Driver:

Write Protected

Passthru Link ID (dec)

Edit Resource/Owner Timeout (x1 sec)

Channel 0

System Driver:  User Driver:

Mode:

Write Protected

Passthru Link ID (dec)

Edit Resource/Owner Timeout (x 1sec)

OK Cancel Apply Help

### System Configuration

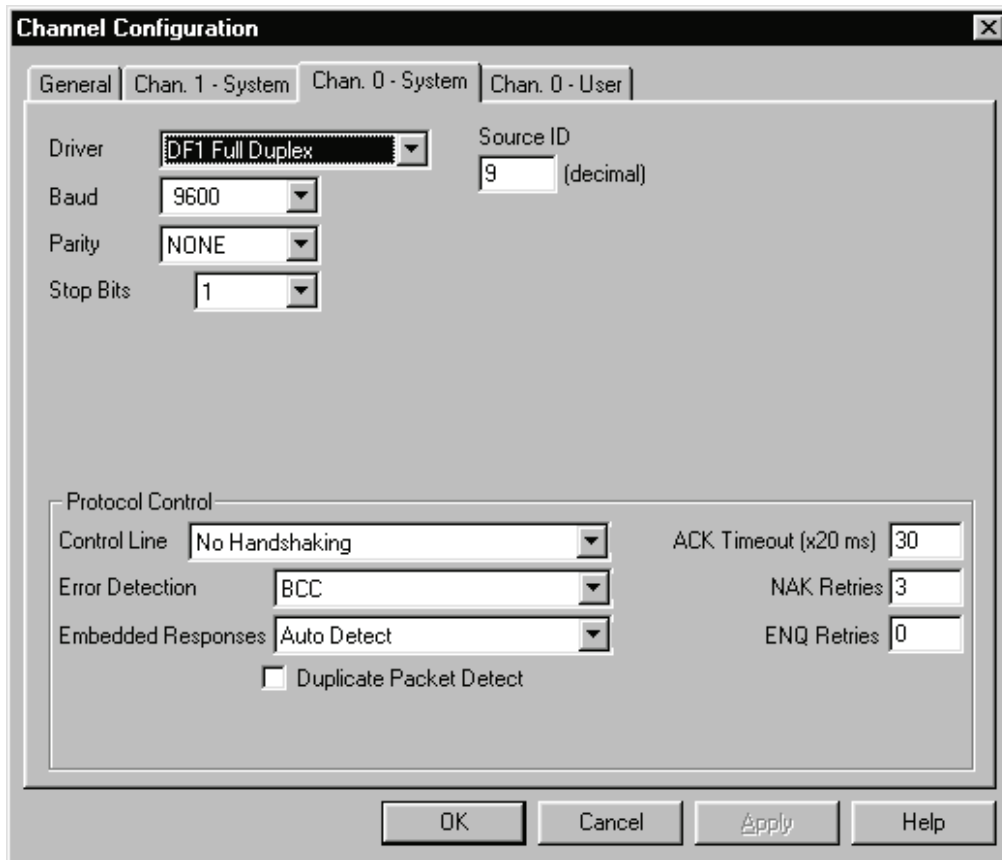

#### Message Sequence Logic

Use the following logic to sequence read and write

message to the Quantum™ LX panel. This logic prevents hang up due to lost communications or message errors.

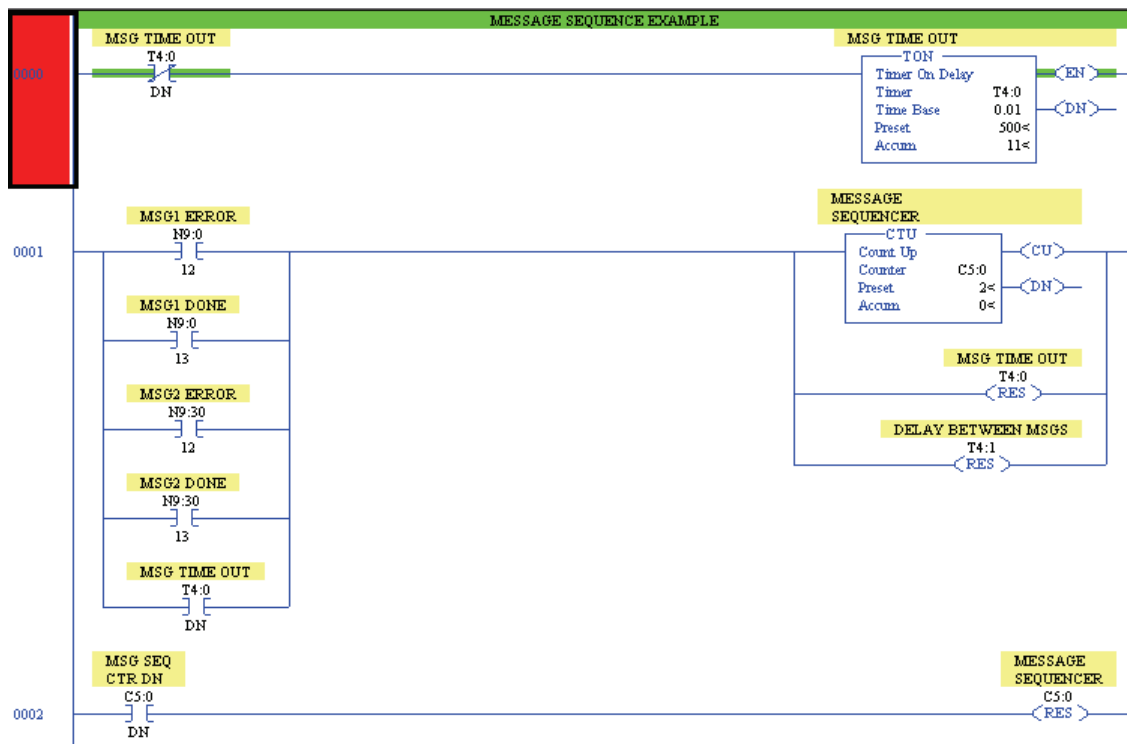

**Message Read Logic**

Use the following logic to read data from the Quantum™ LX panel. To read more data or to read data from several compressors, copy / paste these rungs as needed then modify the control block and setup screen parameters accordingly. The following message read instruction will be executed whenever counter 5:0 (logic shown above) is equal to 0.

**Delay Between Messages**

The delay timer on rung 3 must be used when communicating to the Quantum™ LX with the 100ms preset as shown. This time delay may be decreased when communicating to more than one compressor provided the messages are alternated between compressors. This time delay is not required for Quantum™ V. 5.0x or earlier.

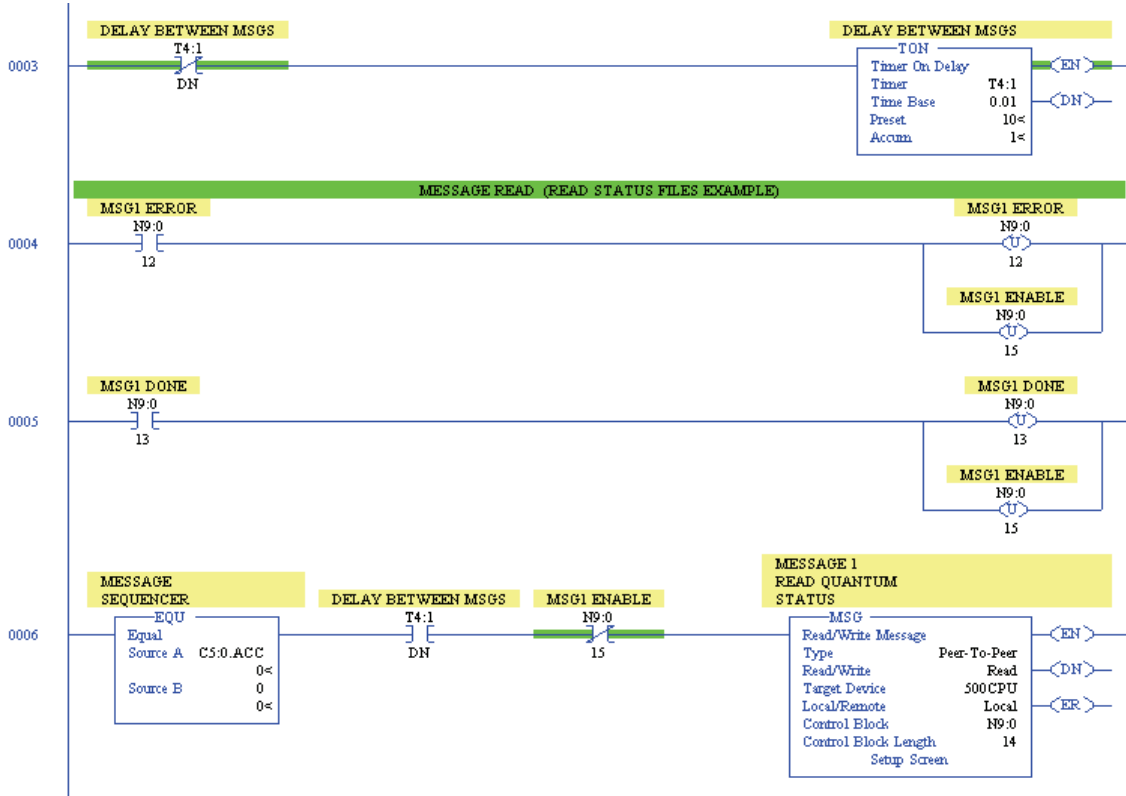

### MESSAGE READ SETUP SCREEN

The following setup screen is programmed to obtain 28 consecutive data files from the Quantum™ LX (ID#1) N10:1

register and place them into the SLC500's N10:1 through N10:28 register. The target address must be changed to for the Quantum™ LX.

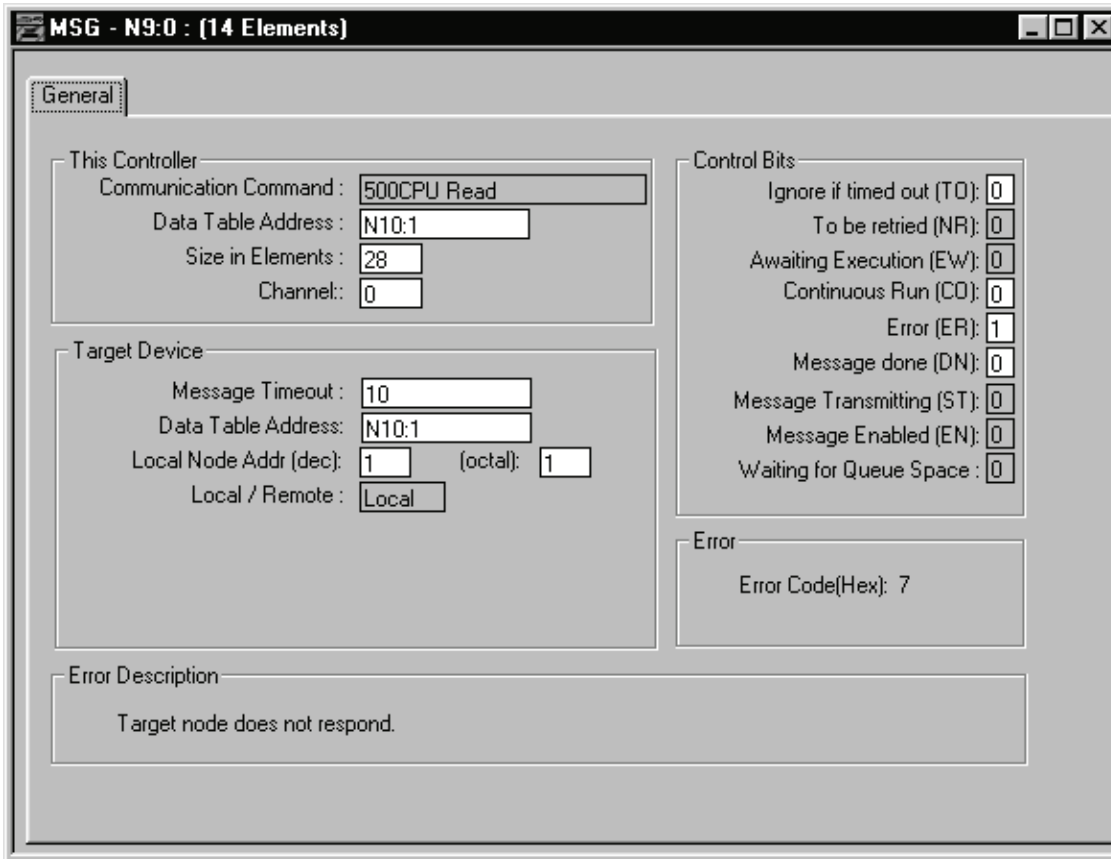

- This Controller: SLC500
  - Data Table Address: Data file location in the SLC500
  - Size in Elements: # of data file to read
  - Channel: Port location on the SLC processor (Channel 0 is the RS-232 port)
- Target Device: Quantum™ Panel
  - Data Table Address: Data file location in the Quantum™ LX controller.
  - Local Node: Quantum™ LX ID# (Octal)

**Message Write Logic**

Use the following logic to write data from the Quantum™ LX panel. To write more data or to write data to several compressors, copy / paste these rungs as needed then modify the control block and setup

screen parameters accordingly. The following write message instruction will be executed when counter 5:0 (logic shown above) is equal to 1 and when called upon by the change compressor mode bit B3/2. When B3/2 is off, the counter will be incremented to execute the next message in the sequence.

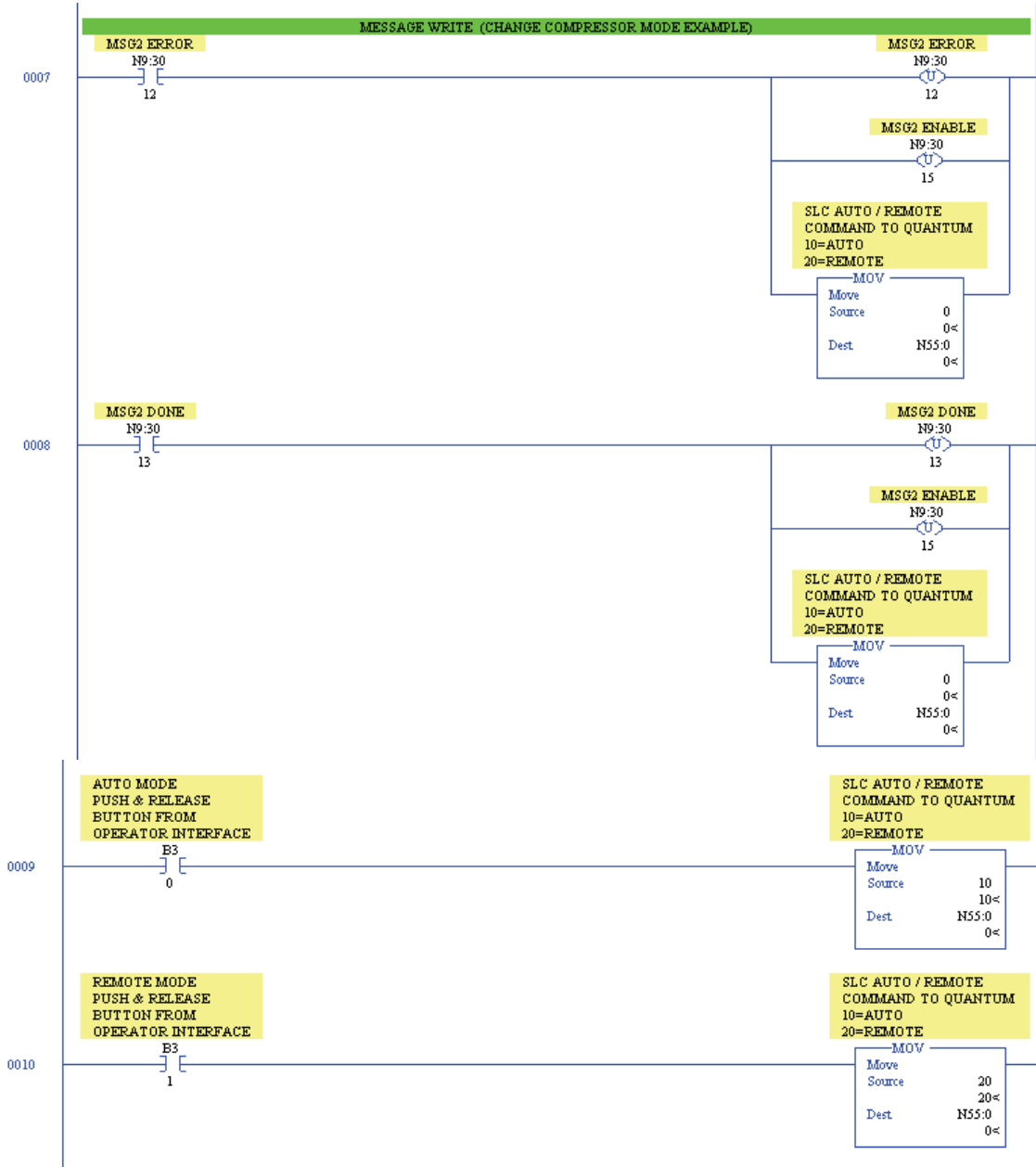

- Continued on next page -

- Continued from previous page -

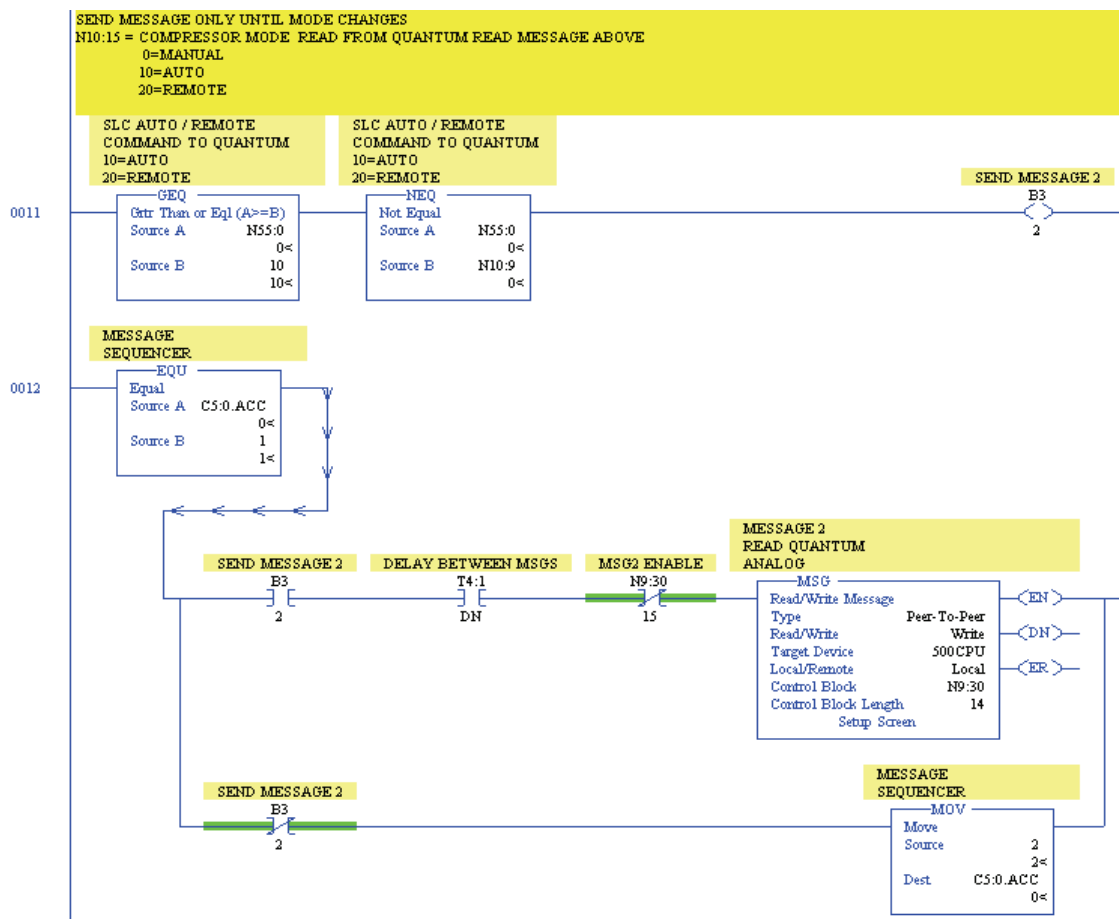

## MESSAGE WRITE SETUP SCREEN

The following setup screen is programmed to write the

compressor mode to the Quantum™ LX (ID#1) N55:3 data file from the SLC500's N55:3 data file. The target address must be changed to for the Quantum™ LX.

- This Controller: SLC500
  - Data Table Address: Data file location in the SLC500
  - Size in Elements: # of data file to read
  - Channel: Port location on the SLC processor (Channel 0 is the RS232 port)
- Target Device: Quantum™ Panel
  - Data Table Address: Data file location in the Quantum™ controller.
  - Local Node: Quantum™ ID# (Octal)

### Allen-Bradley Data Access

Data passed to and from the Quantum™ are integer values with one decimal field assumed unless shown otherwise or the command is sent to select two decimal fields. For example, if the data's value is 25.5 then the value 255 is sent. All temperatures are in degree C and all pressures are in PSIA unless the command is sent to select the units of the panel. A mode such as Slide Valve mode is sent as an integer value that represents the mode it is in. For example, a 0 is sent if it is in manual, or a 10 is sent if it is in automatic, or a 20 is sent if it is in Remote Communications.

The value zero (0) is used to represent an *OFF* status and a *DISABLED* option. The value one (1), which is received as a 10, is used to represent an *ON* status and an *ENABLED* option. Only data values that are designated as setpoints are modifiable. *Read Only* is used to help identify what data is not modifiable. The setpoint range is checked to see if it is an allowed setting. If it is not allowed, the setting is not changed. Reference the *Quantum™ Data Tables* in this manual for the address listing and description of data.

A command has been provided that selects whether data to and from the Quantum™ will be returned in the units that are the default (pressure in PSIA and temperature in Degree C) or in the units that are selected to display at the panel.

### EtherNet/IP

Frick Controls supports the use of EtherNet/IP (as described on the [ab.com](http://ab.com) website, under the EtherNet/IP heading) with LX software 6.06 and later. Address mapping follows the Allen-Bradley *N:* format, as shown in the Data Tables under the heading of *AB Address*. Although this protocol is basically self-configuring, if you do have additional questions, please contact Frick Controls.

## MODBUS® Protocol

### General Description

MODBUS® Protocol is a messaging structure developed by Modicon in 1979, used to establish master-slave/client-server communication between intelligent devices. It is a standard, truly open and the most widely used network protocol in the industrial manufacturing environment. The MODBUS® protocol provides an industry standard method that MODBUS® devices use for parsing messages.

Since MODBUS® protocol is a messaging structure, it is independent of the underlying physical layer. It is traditionally implemented using RS-232, RS-422, or RS-485 communications hardware. With the Quantum™ LX, MODBUS® TCP can also be utilized as it applies to Ethernet networks.

The Quantum™ controller is setup to communicate on standard MODBUS® networks using either ASCII (American Standard Code for Information Interchange), RTU or TCP/IP.

The Quantum™ provides the capability to interface with other devices that support serial data communications using the MODBUS® protocol. This is a Master / Slave multi-drop communication method whereby the Quantum™ is setup to be a MODBUS® Slave. The customer's PLC (Programmable Logic Controller) or DCS (Data Communications System, such as a desktop or laptop computer) must be setup as a MODBUS® Master. The Master initiates the reading and writing of data (queries) to a Quantum™. The Quantum™ does not generate its own data, it will only reply to a request by the Master.

The Quantum™ ID number is used as the MODBUS® Slave address (for ASCII and RTU). The Master uses Function Code 3 (Read Holding Registers) to send a request to read data from the Quantum™. The Master uses Function Code 6 (Load Register) to request to change a setpoint or to send a command such as starting the compressor. Up to one hundred and twenty-five (125) data elements can be read with one read request.

The address references are numbered relative to the Frick® addresses in the *Quantum™ Data Table* (see *MODBUS Addressing Note* in the *Quantum™ Data Table* section of this manual for additional information). The Quantum™ only accepts one value with a Load Register request. Changing a setpoint causes the Quantum™ to save the new setpoint to nonvolatile memory. Be careful not to continuously request a setpoint change. Keeping the Quantum™ busy writing to memory will interfere with the Quantum™ communicating to its I/O boards. A communication failure to an I/O

board will cause the compressor to shutdown. For more detail and a list of the data, reference the *Quantum™ Data Table* section of this manual. For details about the actual protocol, reference the Modicon website at <http://www.modbus.com>.

### MODBUS® TCP/IP (Ethernet)

TCP/IP is the common transport protocol of the Internet and is actually a set of layered protocols, providing a reliable data transport highway between Quantum™ LX panels and an Ethernet network. Ethernet has become the standard for factory networking, replacing many of the data-bus systems used in the past.

MODBUS® TCP/IP simply takes the MODBUS® instruction set and transparently wraps TCP/IP around it. Unlike MODBUS® ASCII and RTU, there no parameters that need to be set (such as baud rate, data bits, etc.).

**NOTE:** When using Modicon Setup Software, ensure that:

- Head number = Rack Position (position of Ethernet card in its rack)
- Socket # = 502

Frick® Controls utilizes function codes 3 (Read), 6 (Write) and 16 (Multiple Write) of the TCP/IP protocol. Use port 502 for Modbus TCP/IP communications. The value used for the Modbus ID must be greater than zero.

### MODBUS® TCP LOG

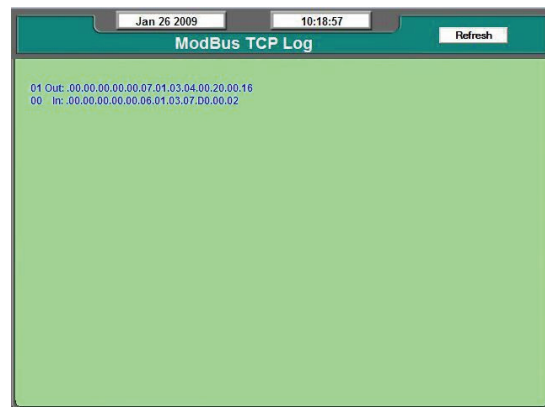

The following user selectable button is provided:

**[Refresh]**

This screen allows the technician to view the ModBus TCP data communications information that the Quantum™ LX is receiving and transmitting.

Each time a new command is sent or received, the screen will need to be refreshed by selecting the **[Refresh]** button.

The top line of data is the most recent activity. At the left of each line, you should see whether the data is *IN* or *OUT* (Response or Command), and the actual data (in Hexadecimal format). This information can be used to compare against the data being sent and received at the other end of

the communications link, to verify proper operation.

Refer to the following table for an example of how the data packets are created, using the data that has been shown on the above screen.

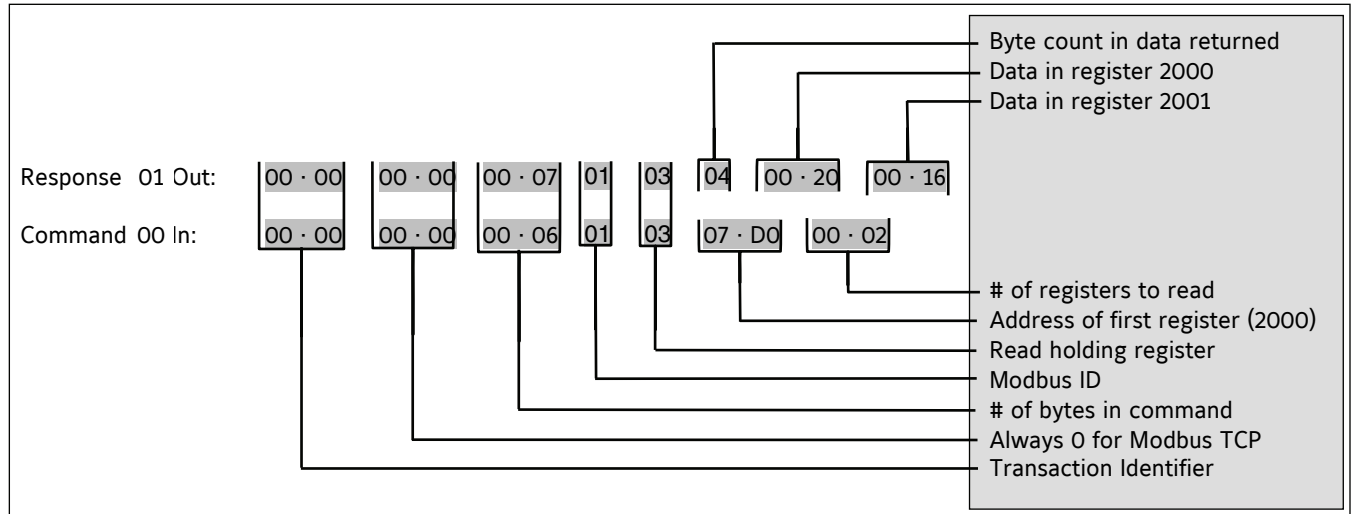

### MODBUS® ASCII (Serial Communications)

In the ASCII Transmission Mode (American Standard Code for Information Interchange), each character byte in a message is sent as 2 ASCII characters. This mode allows time intervals of up to a second between characters during transmission without generating errors. Some particulars about MODBUS® ASCII:

- The device address field of the message frame contains two characters (16 bits).
- The function code field of the message frame will contain two characters (16 bits).
- Word size is selectable.
- Error checking is accomplished using LRC (Longitudinal Redundancy Check).
- Hyperterminal can be used to test communications.

### MODBUS® RTU (Serial Communications)

In RTU (Remote Terminal Unit) Mode, each 8-bit message byte contains two 4-bit hexadecimal characters, and the message is transmitted in a continuous stream. The greater effective character density increases throughput over ASCII mode at the same baud rate. Some particulars about MODBUS® RTU:

- The device address field of the message frame contains 8 binary bits.
- The function code field of the message frame will contain 8 binary bits
- Word size is selectable.
- Error checking is accomplished using CRC (Cyclical Redundancy Check).

- Hyperterminal cannot be used to test communications.

### Serial Port Configuration Of The Master

- 7 or 8 Bits per Character (Data Bits)
- Odd, Even or No Parity
- 1 or 2 Stop Bits
- No Handshake

### Data Packet

The MODBUS® protocol establishes the format for the Master's query by creating a message (data packet) as follows:

- Assign the device address (Quantum™ panel ID #). The address field of a message frame contains two characters for ASCII, or 8 bits for RTU. Valid Quantum™ device addresses are in the range of 01 – 99 decimal. A master addresses a Quantum™ by placing the Quantum™ address in the address field of the message. When the Quantum™ sends its response, it places its own address in this address field of the response to let the Master know which Quantum™ is responding.
- An 8-bit function code defining the requested action (Query):
- Function Code 3 - to read holding registers (sends a request to read data from the Quantum™).
- Function Code 6 to load a register (to request to change a setpoint or to send a command such as starting the

compressor), or a function code 16 (RTU only) to load multiple registers.

- Any data to be sent (Response). The data field is constructed using sets of two hexadecimal digits, in the range of 00 to FF hexadecimal. These are to be made from a pair of ASCII characters (ASCII), or one 8-bit for RTU. The data field of messages sent from a Master to the Quantum™ devices contains additional information which the Quantum™ must use to take the action defined by the function code. This can include items like discrete and register addresses, the quantity of items to be handled, and the count of actual data bytes in the field. If no error occurs, the data field of a response from a Quantum™ to a Master contains the data requested. If an error occurs, the field contains an exception code that the Master application can use to determine the next action to be taken.
- An error-checking field.

## The Query

The function code in the query tells the addressed Quantum™ what kind of action to perform. The data bytes contain any additional information that the Quantum™ will need to perform the function. For example, function code 03 will query the Quantum™ to read holding registers and respond with their contents. The data field must contain the information telling the Quantum™ which register to start at and how many registers to read. The error check field provides a method for the Quantum™ to validate the integrity of the message contents.

## The Response

If the Quantum™ makes a normal response, the function code in the response is an echo of the function code in the query. The data bytes contain the data collected by the Quantum™, such as register values or status. If an error occurs, the function code is modified to indicate that the response is an error response, and the data bytes contain a code that describes the error. The error check field allows the master to confirm that the message contents are valid.

## Data Field

The data field is constructed using sets of two hexadecimal digits, in the range of 00 to FF hexadecimal. For ASCII, these can be made from a pair of ASCII characters. For RTU, this is one 8-bit number.

The data field of messages sent from a master to the Quantum™ devices contains additional information which the Quantum™ must use to

take the action defined by the function code. This can include items like discrete and register addresses, the quantity of items to be handled, and the count of actual data bytes in the field.

For example, if the master requests a Quantum™ to read a group of holding registers (function code 03), the data field specifies the starting register and how many registers are to be read.

If no error occurs, the data field of a response from a Quantum™ to a Master contains the data requested. If an error occurs, the field contains an exception code that the Master application can use to determine the next action to be taken.

## Error Checking

### ASCII

In ASCII mode, when data is transmitted to and from the Quantum™ Controller, each message has an Error Checking value appended to the end of the message. Longitudinal Redundancy Check, or LRC, is used as the method for verifying that the ASCII message sent from the transmitting device was properly received by the receiving device.

The Longitudinal Redundancy Check (LRC) field is one byte, containing an eight-bit binary value. The LRC value is calculated by the transmitting device, by adding together successive eight-bit bytes of the message, discarding any carries, and then two's complementing the result. It is performed on the ASCII message field contents excluding the colon character that begins the message, and excluding the CRLF pair at the end of the message. The LRC is then appended to the message as the last field preceding the CRLF (Carriage – Line Feed) characters. Each new addition of a character that would result in a value higher than 255 decimal simply rolls over the field's value through zero. Because there is no ninth bit, the carry is discarded automatically.

The receiving device recalculates an LRC during receipt of the message, and compares the calculated value to the actual value it received in the LRC field. If the two values are not equal, an error results.

### RTU

In RTU mode, messages include an error-checking field that is based on a Cyclical Redundancy Check (CRC) method. The CRC field checks the contents of the entire message. It is applied regardless of any

parity check method used for the individual characters of the message.

The CRC field is two bytes, containing a 16-bit binary value. The CRC value is calculated by the transmitting device, which appends the CRC to the message. The receiving device recalculates a CRC during receipt of the message, and compares the calculated value to the actual value it received in the CRC field. If the two values are not equal an error results.

The CRC is started by first preloading a 16-bit register to all 1's. Then a process begins of applying successive 8-bit bytes of the message to the current contents of the register. Only the eight bits of data in each character are used for generating the CRC. Start and stop bits, and the parity bit, do not apply to the CRC.

During generation of the CRC, each 8-bit character is exclusive ORed with the register contents. Then the result is shifted in the direction of the least significant bit (LSB), with a zero filled into the most significant bit (MSB) position. The LSB is extracted and examined. If the LSB was a 1, the register is then exclusive ORed with a preset, fixed value. If the LSB was a 0, no exclusive OR takes place.

This process is repeated until eight shifts have been performed. After the last (eighth) shift, the next 8-bit byte is exclusive ORed with the register's current value, and the process repeats for eight more shifts as described above. The final contents of the register, after all the bytes of the message have been applied, is the CRC value.

When the CRC is appended to the message, the low-order byte is appended first, followed by the high-order byte.

## Framing

A message frame is used to mark the beginning and ending point of a message allowing the receiving device to determine which device is being addressed and to know when the message is completed. It also allows partial messages to be detected and errors flagged as a result.

### ASCII

In ASCII mode, messages start with a colon ( : ) character (3A hex), and end with a carriage return-line feed (CRLF) pair (0D and 0A hex).

The allowable characters transmitted for all other fields are hexadecimal 0 - 9, A - F.

All Quantum™ panels connected to the network monitor the network bus continuously for the colon character. When one is received, each Quantum™ decodes the next field (the address field) to find out if it is the addressed device.

A MODBUS® message is placed by the transmitting device into a frame that has a known beginning and ending point. This allows receiving devices to begin at the start of the message, read the address portion and determine which device is addressed, and to know when the message is completed. Partial messages can be detected and errors can be set as a result.

A typical message frame as sent by the Master is shown below:

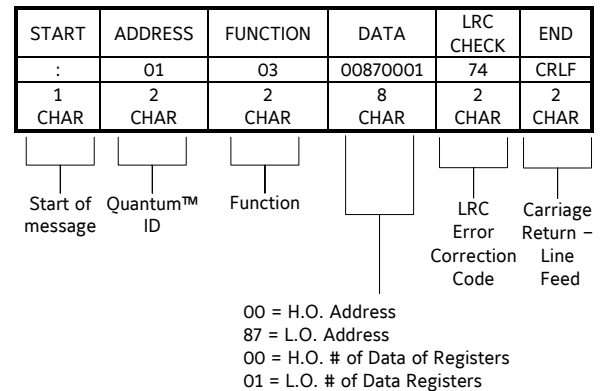

## RTU

In RTU mode, messages start with a silent interval of at least 3.5 character times. This is most easily implemented as a multiple of character times at the baud rate that is being used on the network (shown as T1-T2-T3-T4 in the figure below). The first field then transmitted is the device address.

The allowable characters transmitted for all fields are hexadecimal 0-9, A-F. Networked devices monitor the network bus continuously, including during the 'silent' intervals. When the first field (the address field) is received, each device decodes it to find out if it is the addressed device.

Following the last transmitted character, a similar interval of at least 3.5 character times marks the end of the message. A new message can begin after this interval. The entire message frame must be transmitted as a

continuous stream. If a silent interval of more than 1.5 character times occurs before completion of the frame, the receiving device flushes the incomplete message and assumes that the next byte will be the address field of a new message.

Similarly, if a new message begins earlier than 3.5 character times following a previous message, the receiving device will consider it a continuation of the previous message. This will set an error, as the value in the final CRC field will not be valid for the combined messages. A typical message frame is shown below:

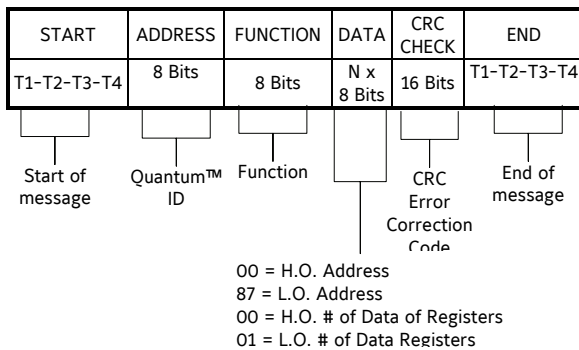

**ASCII Query (Read) Example**

To demonstrate how an address within the Quantum™ may be read, the following test can be performed using Windows HyperTerminal (NOTE: Hyperterminal cannot be used to test RTU or TCP/IP):

As an example, a MODBUS® command will be created and sent to obtain the actual Discharge Pressure value of a compressor. Using the address tables found later in this manual, locate the address for Discharge Pressure. In this case, it is Frick® Address 2003 (decimal). Since this is the only address we are interested in obtaining the value of, send the following message:

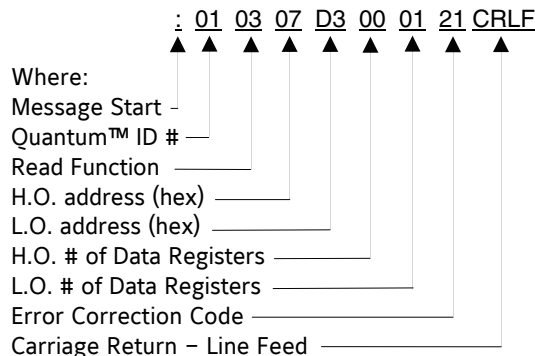

Look at this message on a more basic level, to understand how the address that we are requesting is arrived at. We want to know the

actual value of the Discharge Pressure, Frick® Address 2003 (decimal).

The first part of the message will be a Colon (:). This represents a heads up alert that data is coming:

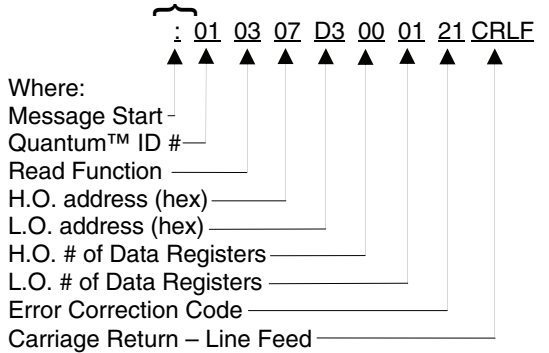

Any time that a message is sent, all of the Quantum™ panels on the MODBUS® network will become active, communications-wise, once the Colon appears. Next, the panels will look at the first byte following the Colon (:). If this byte equals the Panel ID # of the particular Quantum™ being queried, it will immediately finish reading the remainder of the message. If the byte does not equal its ID #, the message will be ignored.

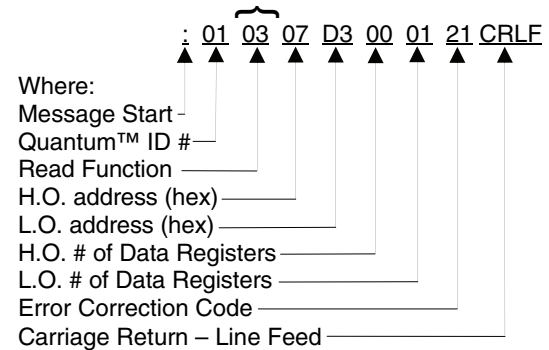

In this particular example, we are strictly looking to request to view a data value, so we will be performing a read function (03):

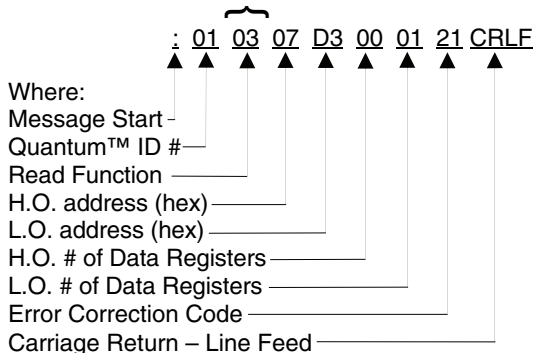

22003 decimal equals 07D3 hex. Looking at our example, we see that we need a H.O. (High Order) address and a L.O. (Low Order) address. Since all data sent and received is in ASCII Hex

Byte format, we need to look at D3 Hex as the Low Order portion of the address. The High Order portion is 07. Now our decimal 2003 is formatted as 07D3 Hex.

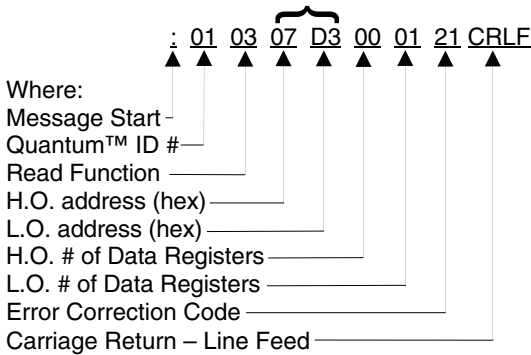

Since we are only looking for this one address, and no other, we can say that we are only looking for one Data Address. Our Data Address part of the data packet is also looking for a High and a Low Order value. Fortunately, the number one (1) is the same in decimal as it is in Hex, therefore, the Low Order Address is 01 (hex). The High Order Address is 00 (hex), so our decimal 1 is formatted as 0001 (hex).

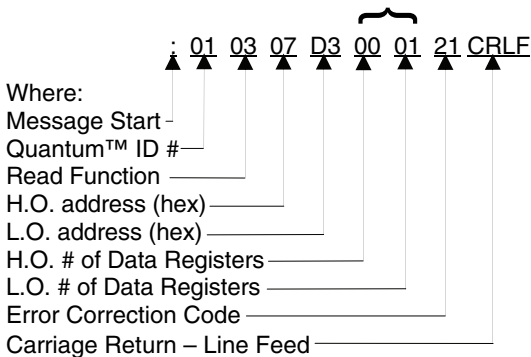

In order to ensure that the Quantum™ in question receives the data request accurately, we must append an Error Check byte to the end of the message. This is accomplished by adding each of the byte pairs (hex) that we have generated thus far:

$$01 + 03 + 07 + D3 + 00 + 01 = DF \text{ hex}$$

Next, subtract DF (hex) from 100 (hex):

$$100 \text{ (hex)} - DF \text{ (hex)} = 21 \text{ (hex)}$$

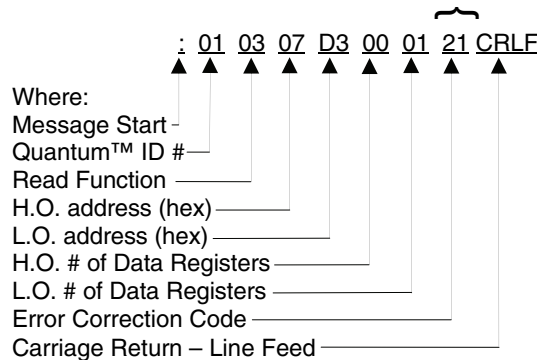

After the entire data packet has been created, simply press the **[Enter]** key, a Line Feed will automatically be sent also.

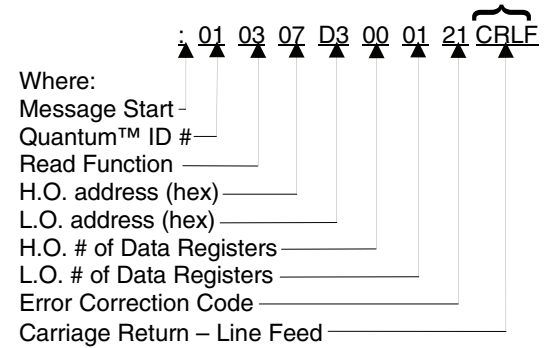

### ASCII Write Example

To demonstrate how an address within the Quantum™ LX may be written to, the following test can be performed using Windows HyperTerminal (**NOTE:** Hyperterminal cannot be used to test RTU or TCP/IP communications).

As an example, a MODBUS® command will be created and sent to the Quantum™ to set *Regulation Mode 1 Setpoint* to 100.0 PSIA. First, be aware that data sent to and received by the Quantum™ has one decimal place assumed. This means that to send the value of 100.0, you actually need to send 1000. Using the address tables found later in this manual, locate the address for the *Regulation Mode 1 Setpoint*. In this case, it would be Frick® Address 7150 (decimal).

Since this is the only address we are interested in writing to, send the following message:

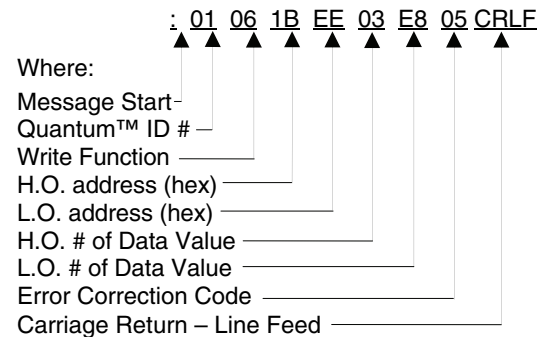

Look at this message on a more basic level, to understand how the address that we are writing to is arrived at. We want to send the value of 1000 (100.0) to the *Regulation Mode 1 Setpoint*, Frick® Address 7150 (decimal).

The first part of the message will be a Colon (:). This represents a heads up alert that data is coming down the line.

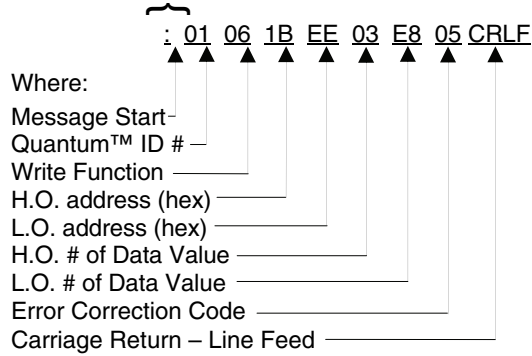

Any time that a message is sent, all of the Quantum™ panels that are on the MODBUS® network will become active, communications wise, once the Colon appears. Next, all panels will look at the first byte following the Colon (:). If this byte equals the Panel ID # of the particular Quantum™ being queried, it will immediately finish reading the remainder of the message. If the byte does not equal its ID #, the message will be ignored.

In this particular example, we are strictly looking to write a data value, so we will be performing a write function (06):

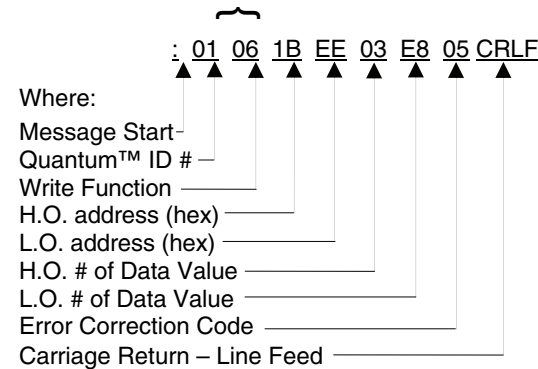

7150 decimal equals 1BEE hex. Looking at our example we see that we need a H.O. (High Order) address and a L.O. (Low Order) address. Since all data sent and received is in ASCII Hex Byte format, we need to look at EE Hex as the Low Order portion of the address. The High Order portion is 1B. Now our decimal 7150 is formatted as 1BEE Hex.

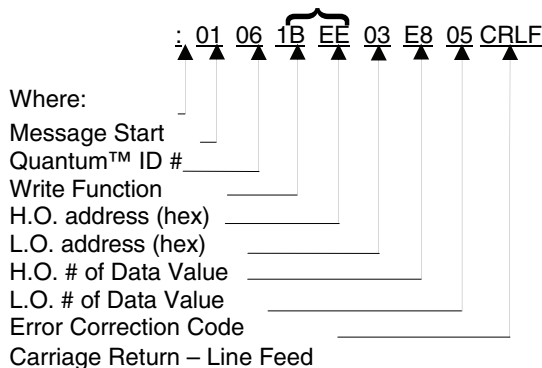

The value that we wish to send is 100.0 (1000). The Data Value part of the data packet is looking for a High and a Low Order value. The number 1000 (dec) must be converted to hexadecimal. This conversion results in a value of 03E8 (hex). Separating 03E8 into two bytes results in the Low Order Value of E8 (hex) and the High Order Value of 03 (hex):

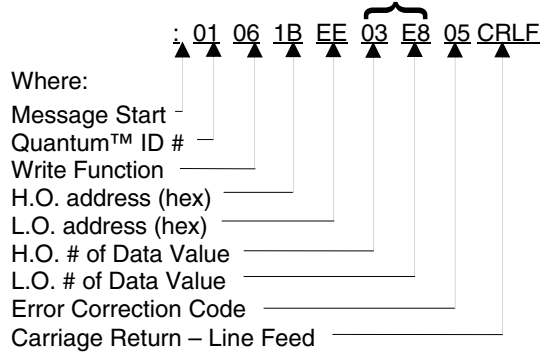

In order to ensure that the Quantum™ in question receives the data request accurately, we must append an Error Check byte to the end of the message. This is accomplished by adding each of the byte pairs (hex) that we have generated thus far:

$$01 + 06 + 1B + EE + 03 + E8 = 1FB \text{ hex}$$

Normally, we would subtract 1FB (hex) from 100 (hex), as in the previous read example. However, in this case we see that 1FB hex is greater than 100 hex. Since the math in this particular example would yield a negative number (FFFF FFFF FF05), we need to modify the value of 1FB in order to provide a positive result. This is accomplished quite simply by dropping the most left hand digit (1FB becomes FB), and then subtracting FB hex from 100 hex:

$$100 \text{ (hex)} - FB \text{ (hex)} = 05 \text{ (hex)}$$

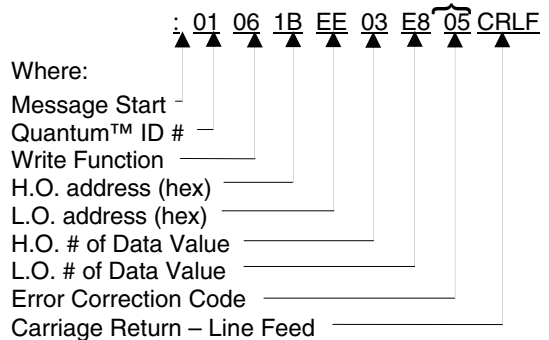

After the entire data packet has been created, simply press the **[Enter]** key, a Line Feed will automatically be sent also.

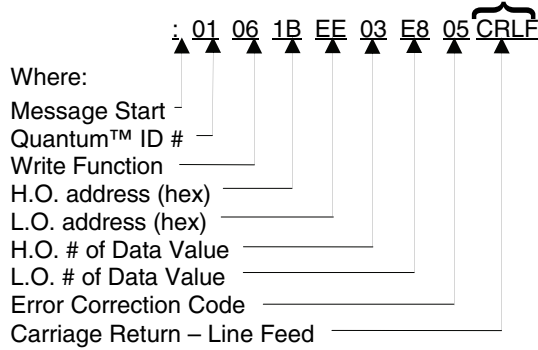

**ASCII Response Example**

If the packet was properly received by the Quantum™, you should see an immediate response in HyperTerminal. In the Query Response (read function) example used earlier, a response of :01030205D025 (hex) was received.

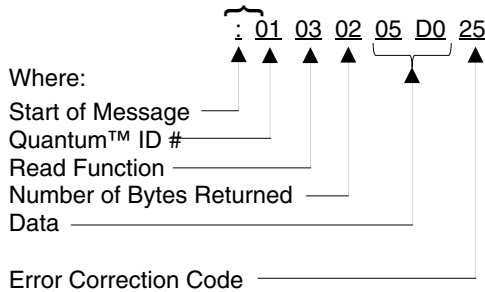

Once again, the first part of the message will be a Colon (:). This represents a heads up alert that data is coming down the line, but since the data is coming from the Quantum™ to the Master this time, the Master will accept it.

After having received the Colon (:), the Master will look at the two bytes that follows it, so that it may determine from which Quantum™ the message is coming from.

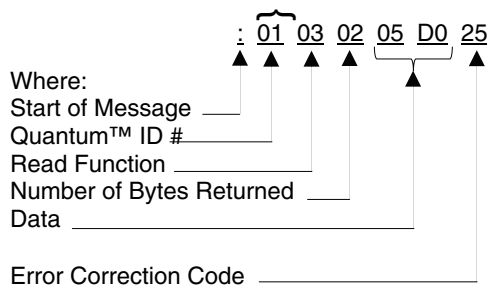

Now that the Master knows which panel is responding, it needs to know which function the panel is responding to. In this case, it sees that it

is a read function, and the Quantum™ is merely returning a value that was previously requested.

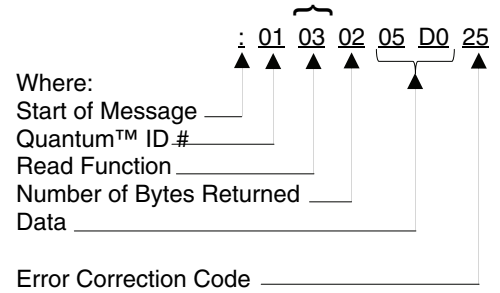

The next byte tells the Master how many bytes of information are being returned as a response. In this case, there are two (2) bytes of valid data.

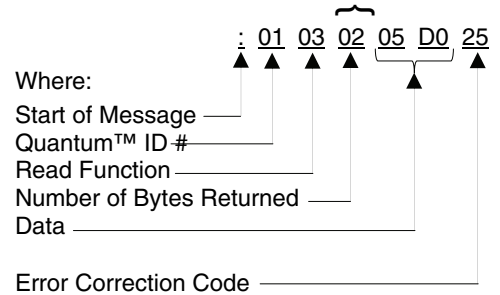

The next two bytes (in this case) are the actual data in response to our original request.

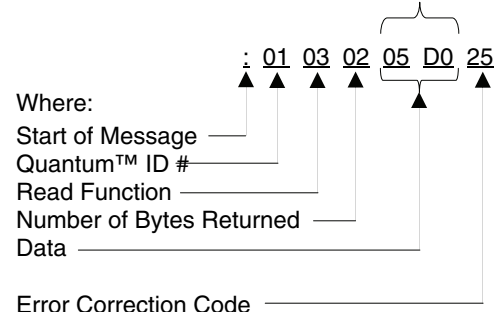

We need to know what this value means. To break it down, we must convert the pair of bytes from Hex to Decimal:

05D0 (hex) = 1488 (decimal)

Data to and from the Quantum™ are integer values with one decimal field assumed unless shown otherwise or the command is sent to select two decimal fields.

From the previous paragraph, we can assume that there is one decimal place to be applied to the data value that was returned. Therefore:

1488 (decimal) = 148.8 (decimal)

All temperatures are in degrees C and all pressures are in PSIA unless the command is sent to select the units of the panel. Therefore:

148.8 (decimal) = 148.8 PSIA

### RTU Query (Read) Example

(NOTE: Hyperterminal cannot be used to test RTU):

In the following example, a MODBUS® command is sent to obtain the actual Discharge Pressure value of a compressor. Refer to the following example to see what this message packet would look like:

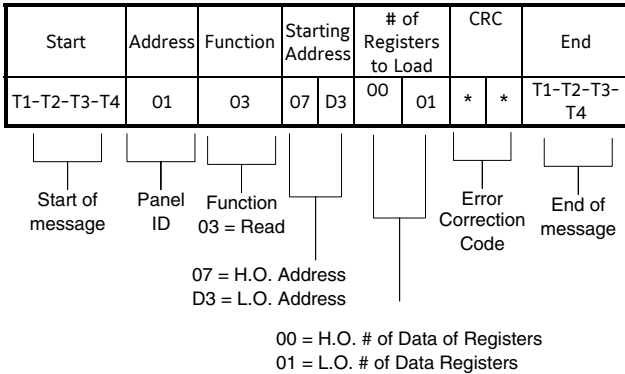

\* The CRC value is calculated by the transmitting device, which appends the CRC to the message.

### RTU Response Example

Using the RTU Read example just shown, a typical response would look like:

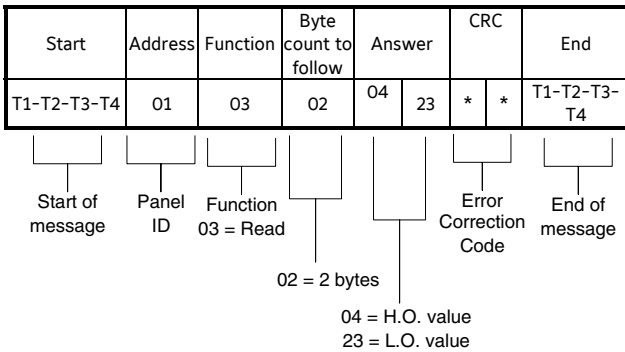

The returned value in the above example is 0423 hex. Converting this to decimal equates to 1059, and assuming a decimal point gives an answer of 105.9 (PSIA or Panel units, depending on which has been selected).

### MODBUS® NOTES

This has been an example of how the Quantum™ Controller uses the MODBUS® Protocol. It is hoped that the information provided here will assist the end user in writing applications that will allow the Quantum™ to be implemented into networks that the customer may already have in use.

This information is subject to change at any time, and is provided as a reference only. Not all areas of the MODBUS® Protocol can be handled in this document.

Some additional information regarding MODBUS® Protocol that the end user should be aware of:

- There are many versions of MODBUS® Protocol that are available, and an application that works properly on one system, may not function identically on another.
- Some versions of MODBUS® Protocol may require the user to increment any referenced addresses by 1 (one). For instance, if you wanted to look at Frick® Address 2003, you may need to actually look at address 2004. The Quantum™ addressing begins at 0 (zero), whereas some MODBUS® Protocols begin at 1 (one), therefore, you may need to compensate.
- 7 or 8 bits selectable.
- 1 or 2 Stop bits selectable.
- Parity can be set to *None*, *Odd* or *Even*
- When using MODBUS® protocol (other than the Hyperterminal example shown earlier), it is necessary to use the MODBUS® Address column as shown in the Quantum™ Data Tables. These addresses should work for most applications.
- Follow the Frick® specifications for data communications requirements.
- Hyperterminal can be used to test ASCII, but not RTU or TCP/IP communications.

**NOTE:** Be careful not to continuously request a setpoint change. It is to be expected that communications may slow down during the process of writing setpoints or clearing alarms. Both of these processes involve writing to either EEPROM or Flash Memory and does take some time. If communication requests are being sent faster than once every couple of seconds, there will be temporary slowdowns during these processes.

### MODBUS® Data Access

Data passed to and from the Quantum™ are integer values with one decimal field assumed unless shown otherwise or the command is sent to select two decimal fields. For example, if the data's value is 25.5 then the value 255 is sent. All temperatures are in degree C and all pressures are in PSIA unless the command is sent to select the units of the panel. A mode such as Slide Valve mode is sent as an integer value that represents the mode it is in. For example, a 0 is sent if it is in manual, or a 10 is sent if it is in automatic, or a 20 is sent if it is in remote. The value zero (0) is used to represent an *OFF* status and a *DISABLED* option. The value one (1), which is received as a 10, is used to represent an *ON* status and an *ENABLED* option. Only data values that are designated as setpoints are modifiable. *Read Only* is used to help identify what data is not modifiable. The setpoint range is checked to see if it is an allowed setting. If it is not allowed, the setting is not changed. Reference the *Quantum™ Data Tables* in this manual for the address listing and description of data.

A command has been provided that selects whether data to and from the Quantum™ will be returned in the units that are the default (pressure in PSIA and temperature in Degree C) or in the units that are selected to display at the panel.

## PROFINET

### GENERAL DESCRIPTION

Starting with Version 6.09, the Quantum™ LX has the ability to communicate via the PROFINET protocol. The Quantum™ LX will be a PROFINET CBA (Component Based Automation) device and will act strictly as a provider or server of data.

The Quantum™ LX, a PROFINET component, will be addressed by its IP address. The Physical Device that is the Quantum™ LX will have one Logical Device, and when initially contacted, it will respond with a Logical Device name of "Ldev\_Registers". This Logical Device will have one Runtime Automation Object (RT-Auto) assigned to it, and the name of the RT-Auto will be "RTAuto\_QuantumLXRegisters".

A client will have the ability to transfer data to and from the Quantum™ LX via two callable methods (or functions) of the RT-Auto. The names of these methods are ReadRegisters and WriteRegister. These methods and their parameters will be described by referring to their definitions contained in the IDL file used in the development of this PROFINET component.

IDL (Interface Description Language) is a language for describing the interfaces (the properties and methods) of a component. The IDL file definitions of the methods ReadRegisters and WriteRegister are as follows:

```
HRESULT ReadRegisters([in] LONG iStart,
                      [in] LONG iCount,
                      [out] VARIANT *pData);
```

```
HRESULT WriteRegister([in] LONG iStart,
                      [in] LONG iValue);
```

Parameter descriptions for ReadRegisters:

**iStart** – the register # of the first register to read

**iCount** – the number of registers to read

**pData** – pointer to an array that will receive the data

Parameter descriptions for WriteRegister:

**iStart** – the register # of the register to write

**iValue** – the value to write

#### Notes:

- The data returned in pData and the value supplied in iValue is assumed to be x10.
- Only one register may be written at a time.
- Port 135 is used to both send and receive data.
- The register number map is the same as for MODBUS.

## HYPERTERMINAL

### Description

HyperTerminal is a terminal emulation program which resides in the Microsoft Windows environment, and as such, will normally be found on any computer that is running Microsoft Windows. HyperTerminal provides a method by which the end user may verify conclusively that their Quantum™ controller is functioning properly, and as designed, with respect to external communications to remote devices.

**NOTE:** Hyperterminal can only be used to test MODBUS® ASCII. It CANNOT be used to test Allen-Bradley or MODBUS® RTU or TCP/IP.

Many times, the Quantum™ controller will be installed into an environment whereby the end user wishes to communicate to it, either through a PLC (Programmable Logic Controller), a desktop computer for the purpose of monitoring/controlling plant operations through HMI (Human Machine Interface), or any number of other communications applications.

The purpose of this desired communications typically involves viewing and changing setpoints, starting and stopping a compressor, viewing alarm and shutdown information, and viewing current operating conditions.

When first connecting a Quantum™ panel to a communications network, it would be highly desirable to determine that all necessary parameters (jumper settings, panel setup, and cabling) are properly met so that communications may be established quickly with the Quantum™, so that time is not lost in trying to troubleshoot a potentially simple problem.

A connection from a Comm port of a computer running Microsoft Windows can be used to connect to Com-1 or Com-2 of the Quantum™.

### Setting up Hyperterminal

- You will need to locate either a lap top or desktop computer that has Hyperterminal installed.
- Turn on the power for the lap top.
- After the laptop has fully booted, locate the Hyperterminal program. (Hyperterminal is usually found in the *Accessories* folder). If Hyperterminal can't be found there, try using the *Find File* command, and search the entire hard drive.
- Be aware that the screens that are actually shown on the test computer may or may not appear exactly as shown here. Various versions of Windows can affect the appearance, as well as whether or not the screen has been maximized, or if it has been scaled to a smaller size. Regardless of how the screen work appears, the function of the screen work is what is important, and that function is not affected by the way the screen looks.
- Once Hyperterminal has been located, execute it. A dialog box will appear. You will be prompted to enter a name for the *New Connection*. Type in whatever name you would like to use, *Frick®* was used in this example. This name will also create a file once you are finished, saving all of the setup parameters for future use. It is recommended that a name be chosen to reflect the type of Protocol that you will be using as you may wish to setup for various protocols. Once you have entered a name, click [OK].

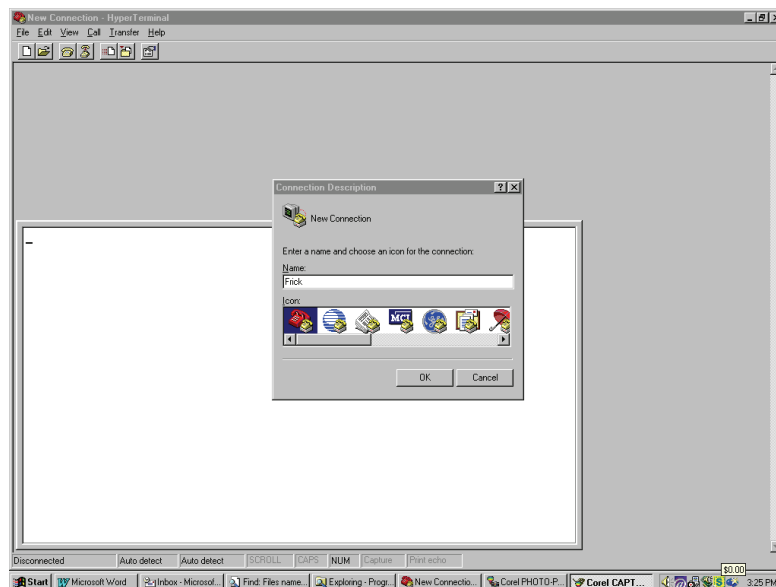

A new dialog box will be shown asking to select a Com port (choose the Com port that your communications cable is attached to, this will

normally be Com-1). The phone number box should be blank. Click on **[OK]**.

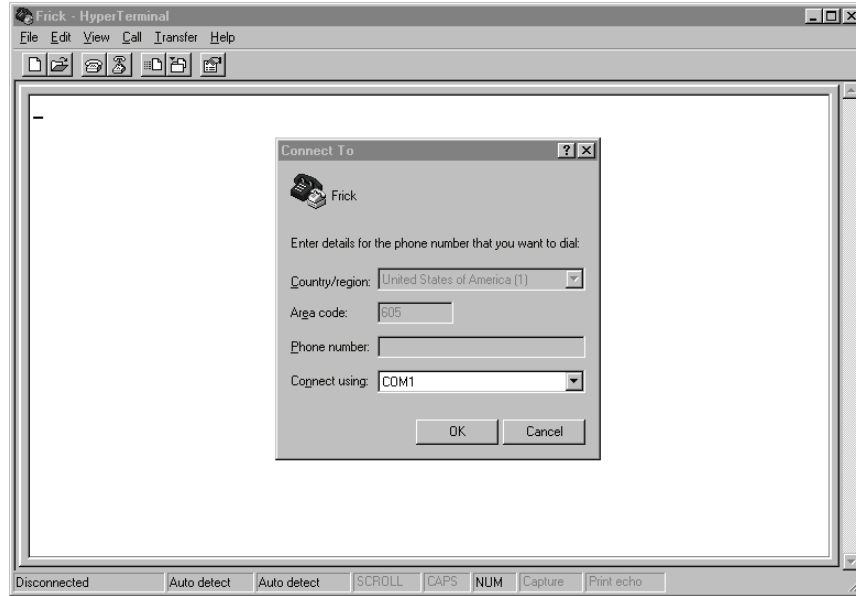

The Com-1 properties dialog box will now appear. The parameters in this box must match the requirements of the protocol that you are wishing to use. The one box that normally would need to be changed from one protocol to the next is the *Data Bits* box.

For the purpose of this document, Frick® # protocol will be used. Refer to the MODBUS® ASCII section of this manual for information on MODBUS®.

Set the five boxes as follows, then click **[OK]**.

- Bits per second: 9600 (must match the Quantum™)
- Data bits: 8
- Parity: None
- Stop Bits: 1
- Flow Control: None

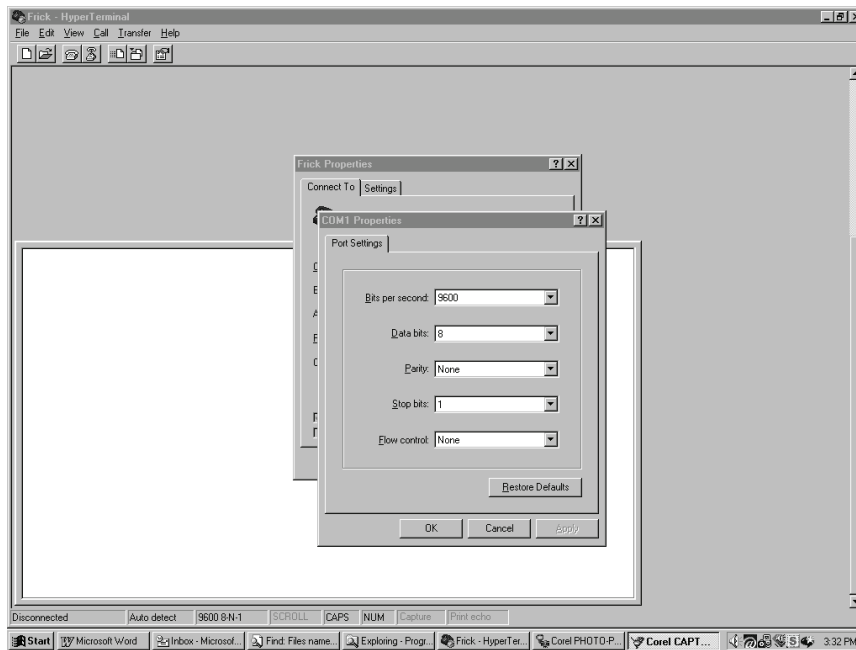

The following screen will appear. This is the screen whereby all communications (out of the computer, and into it) will be shown. When valid data is typed

in here, then sent, the connected device recognizes and responds to that data, and a response will be shown below the sent data. Click on **[File]**.

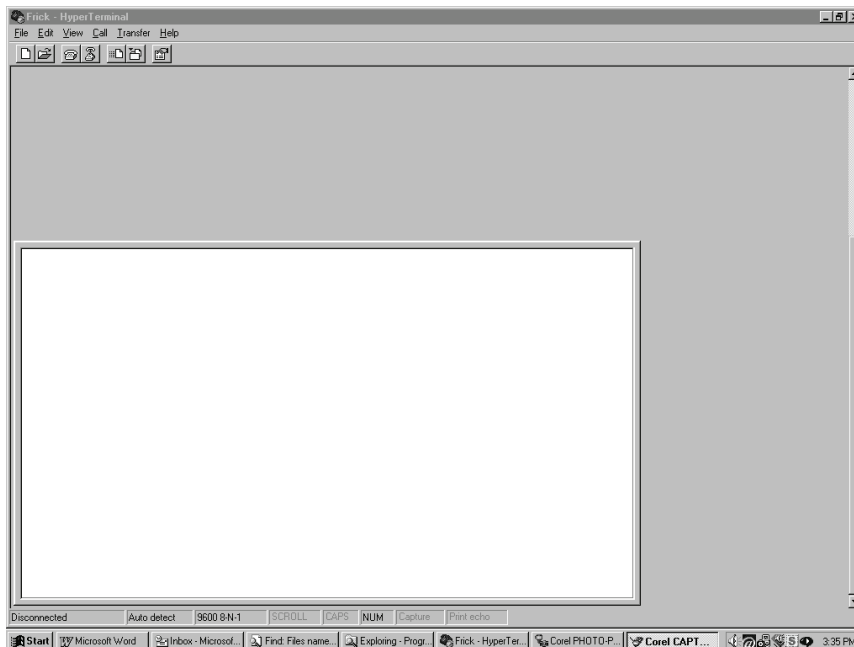

A pull down menu will appear. From this menu, locate and click on **[Properties]**. You will once again see the

following screen. This time, click on the **[Settings]** tab.

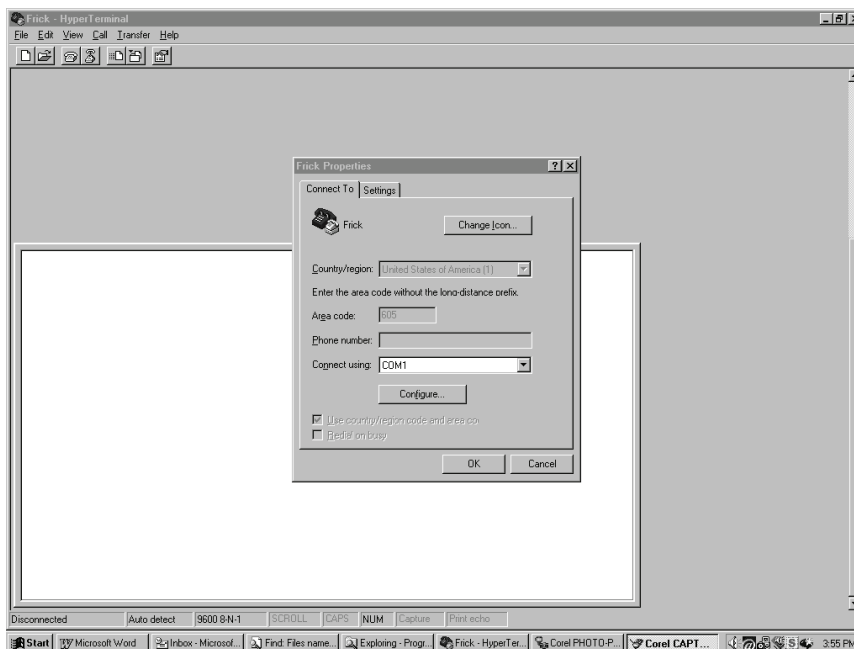

The computer will need to be set up to match the documentation as presented here, for everything to

look and work as shown later. To do this, click on the [ASCII Setup...] button.

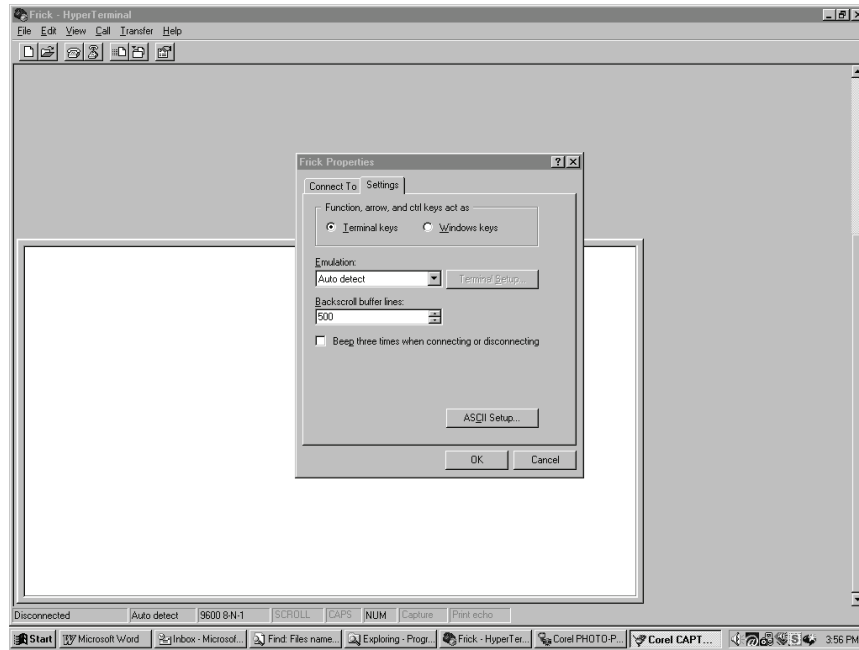

On the *ASCII Setup* screen, for best results, check the boxes according to the following chart:

**For MODBUS® ASCII:**

- Send line ends with line feeds
- Echo typed characters locally
- Append line feeds to incoming line ends
- Wrap lines that exceed terminal width

**For Frick® protocols (# and \$):**

- Echo typed characters locally
- Append line feeds to incoming line ends
- Wrap lines that exceed terminal width

Leave everything else on this dialog box unchanged, then click on [OK].

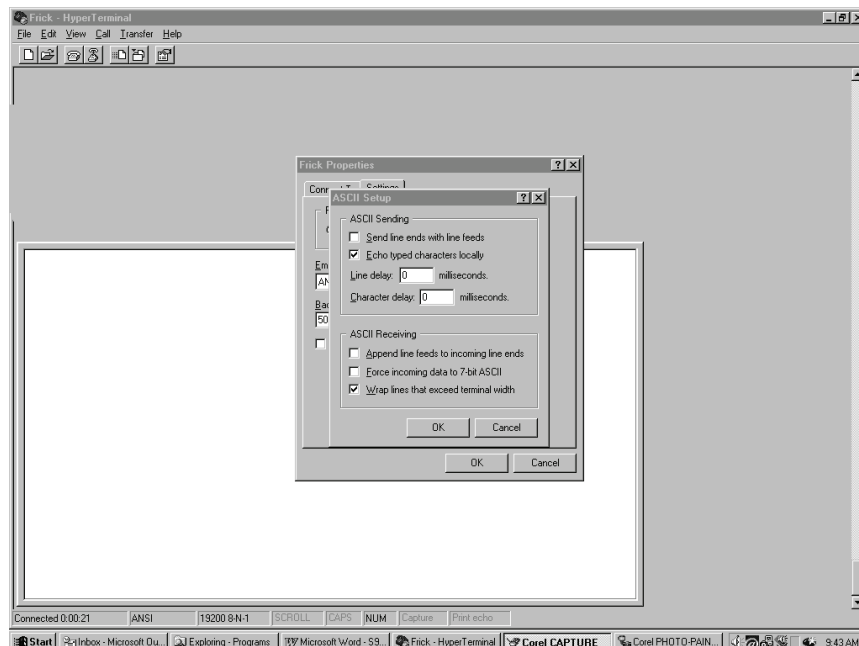

The *Properties* screen will once again be shown. Click on the [OK] button to proceed.

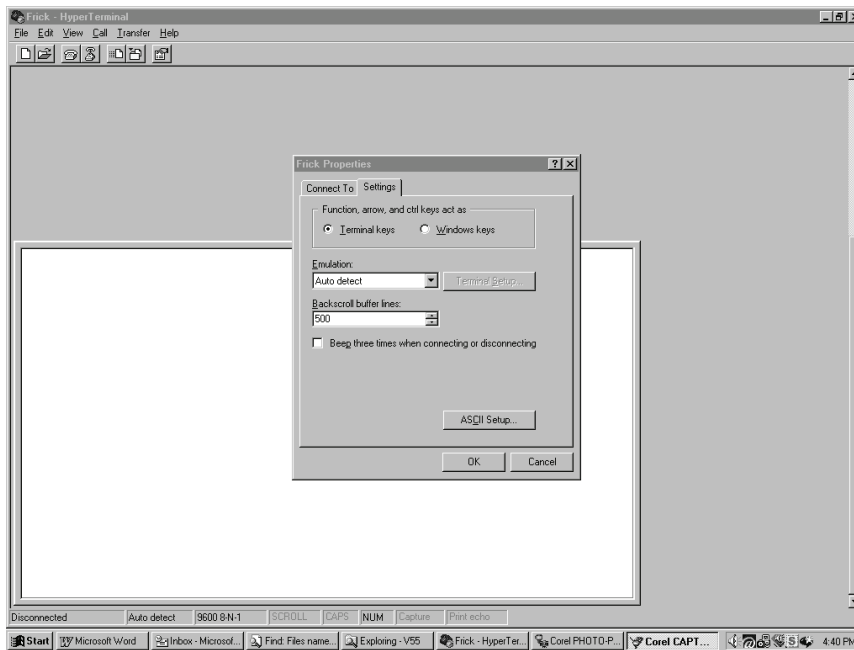

You will now be back to the main Hyperterminal communications screen. This screen will be blank. All communications, both from the computer, and to the

computer (from the Quantum™), will appear on this screen. Proceed to the *Testing Communications* section.

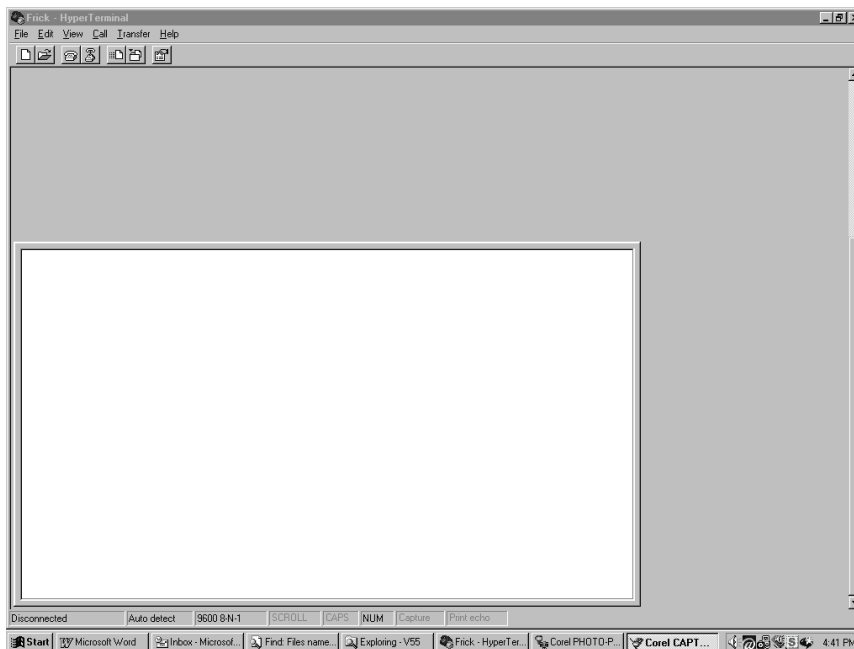

## Testing Communications

Set the keyboard for *CAPS* (so that all capital letters will be typed). Type in the following command: #01I,

then press **[ENTER]**. (This command will request the Quantum™ with ID 01 to send a packet of Information.)

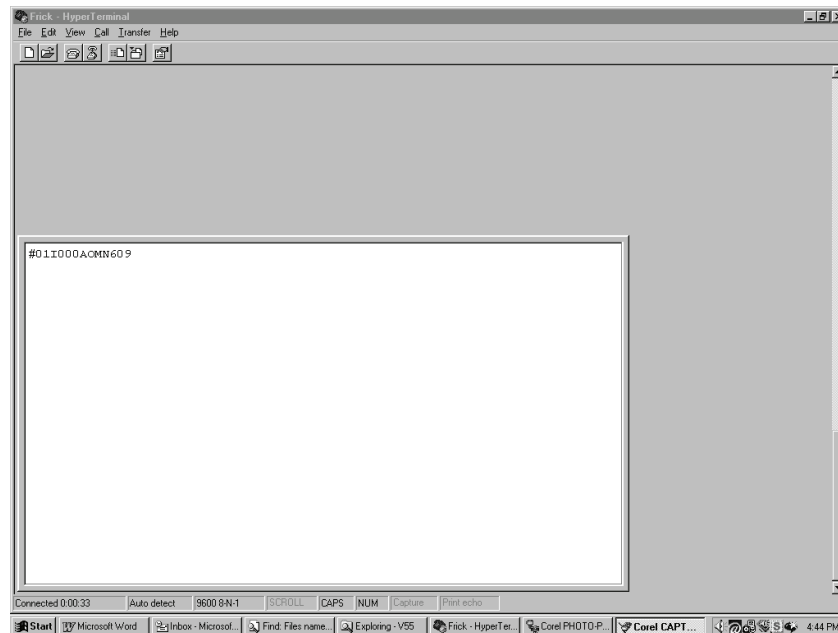

If the communications is working properly, there should be an immediate response from the first Quantum™. The response should look something (but not necessarily exactly) like *#01I000ACMN609*.

If this portion of the test has passed, you can try to communicate to the next (or any Quantum™), by changing the value that you type into the HyperTerminal screen as follows:

Instead of **[#01]**, replace the *01* portion with the ID that you would like to access. For instance, if you wanted to talk to a fourth Quantum™ (ID 4), type in **[#04]**. This should return a message from that Quantum™.

This has been just a brief description of how to check your communications and verify that it is working. Greater detail can be found by consulting tables for each of the protocols in this manual.

## General Notes

Ensure that the Quantum™ communications parameters are correct. This setup can be found on the *Communications* screen. This info must match that of the device that you are trying to talk to at the other end.

There are two red LED's associated with the Com-2 port on the Quantum™ (TX2 & RX2). Ensure that neither of these LED's are on continuously. If one or the other (or both) are on constantly, disconnect the Com cable. If the status of the LED's does not change,

check the wiring connections to the comm port. Ensure that the wiring is not backwards. If the wiring is correct, power the Quantum™ down, then back up. If either or both of the LED's is still on, a bad driver chip may be suspected on the Quantum™, and the board should be replaced.

Once everything has been inspected (cables, jumpers, and setup), try to develop communications from the master. You should see the LED's on the Com-2 port flickering as the Quantum™ talks to the master. If nothing happens, it would be best to consult the *HyperTerminal* section of this manual for more detailed troubleshooting.

If no data appears, or if the data does not match the specific protocol requirements that you are using, then check the following:

- Verify that the communications wiring matches that shown in the drawings at the end of this manual.
- Access the *Communications* screen and verify that the Quantum™ ID is set to the same value that you are trying to access. Also, check that the baud rate matches that of the setup in the properties section of the Hyperterminal example.
- Verify the position of the jumpers by comparing them with the section entitled *Quantum™ Communications Jumpers*.

- Ensure that the data that you have entered in Hyperterminal, exactly matches the example.
- Go back through the *Setting up Hyperterminal* section, and ensure that it has been followed exactly. Repeat the process if necessary.
- If you are using a converter card (to convert the RS-232 signal from the computer to RS-422 or RS-485), then either verify that the converter card is working properly with a

different piece of known functioning equipment, or eliminate it completely by tying into the Quantum™ directly through RS-232.

- The Communications port on the computer is bad. Try to verify this by communicating to a different piece of known good equipment.
- The Communications port on the Quantum™ is bad.

**CONVERSION CHART FOR DECIMAL / HEXADECIMAL / ASCII**

Decimal (DEC)	Hexadecimal (HEX)	ASCII
0	0	ctrl @ NUL
1	1	ctrl A SOH
2	2	ctrl B STX
3	3	ctrl C ETX
4	4	ctrl D EOT
5	5	ctrl E ENQ
6	6	ctrl F ACK
7	7	ctrl G BEL
8	8	ctrl H BS
9	9	ctrl I HT
10	A	ctrl J LF
11	B	ctrl K VT
12	C	ctrl L FF
13	D	ctrl M CR
14	E	ctrl N SO
15	F	ctrl O SI
16	10	ctrl P DLE
17	11	ctrl Q DC1
18	12	ctrl R DC2
19	13	ctrl S DC3
20	14	ctrl T DC4
21	15	ctrl U NAK
22	16	ctrl V SYN
23	17	ctrl W ETB
24	18	ctrl X CAN
25	19	ctrl Y EM
26	1A	ctrl Z SUB
27	1B	ctrl [ ESC
28	1C	ctrl \ FS
29	1D	ctrl ] GS
30	1E	ctrl ^ RS
31	1F	ctrl _ US
32	20	SPACE
33	21	!
34	22	"
35	23	#
36	24	\$
37	25	%
38	26	&
39	27	'
40	28	(
41	29	)
42	2A	*

Decimal (DEC)	Hexadecimal (HEX)	ASCII
43	2B	+
44	2C	,
45	2D	-
46	2E	.
47	2F	/
48	30	0
49	31	1
50	32	2
51	33	3
52	34	4
53	35	5
54	36	6
55	37	7
56	38	8
57	39	9
58	3A	:
59	3B	;
60	3C	<
61	3D	=
62	3E	>
63	3F	?
64	40	@
65	41	A
66	42	B
67	43	C
68	44	D
69	45	E
70	46	F
71	47	G
72	48	H
73	49	I
74	4A	J
75	4B	K
76	4C	L
77	4D	M
78	4E	N
79	4F	O
80	50	P
81	51	Q
82	52	R
83	53	S
84	54	T
85	55	U

Decimal (DEC)	Hexadecimal (HEX)	ASCII
86	56	V
87	57	W
88	58	X
89	59	Y
90	5A	Z
91	5B	[
92	5C	\
93	5D	]
94	5E	^
95	5F	_
96	60	`
97	61	a
98	62	b
99	63	c
100	64	d
101	65	e
102	66	f
103	67	g
104	68	h
105	69	i
106	6A	j
107	6B	k
108	6C	l
109	6D	m
110	6E	n
111	6F	o
112	70	p
113	71	q
114	72	r
115	73	s
116	74	t
117	75	u
118	76	v
119	77	w
120	78	x
121	79	y
122	7A	z
123	7B	{
124	7C	
125	7D	}
126	7E	▣
127	7F	DEL

## QUANTUM™ LX DATA TABLES

The following table shows the three protocol Address ranges that may be utilized for reading/writing data to and from the Quantum™ LX controller; Frick Addresses, Allen-Bradley (AB) Addresses, and Modbus Addresses. This table

also shows the Data Table names, as well as the page numbers within this manual that the pertinent Data Tables may be found:

Frick Address Range	AB Address	Modbus Address	Data Table	Pages
1001 - 1061	N10:1 - N10:61	41002 - 41062	Digital Board Values	61 - 63
2000 - 2081	N20:0 - N20:81	42001-43001	Analog Board Values	64 - 66
3000 - 3081	N30:0 - N30:81	43001 - 43082	Calculated Values	67 - 68
4000 - 4566	N40:0 - N45:66	44001 - 44567	Mode Values	69 - 77
6000 - 6046	N60:00 - N60:46	46001 - 46047	Timer Values	78- 79
7060 - 8558	N100:60 - N115:58	47061 - 48559	Setpoint Values	80 - 109
8910 - 8924	N119:10 - N119:24	48911 - 48925	Commands	110
8950 - 9007	N119:50 - N120:07	48951 - 49008	DBS Setpoint Values	111 - 112
9100 - 9101	N121:00 - N121:01	49101 - 49102	General Setpoint Values	113
9200 - 9314	N122:00 - N123:14	49201 - 49315	VSD (Vyper) Setpoint Values	113 - 116

### DIGITAL BOARD VALUES: (Read Only)

Frick® Address	AB Address	Modbus Address	Read/Write	Description of Data	Digital Board #	Channel #	Module Type
1001	N10:1	41002	R	Oil Level/Oil Switch	1	13	Input
1002	N10:2	41003	R	Capacity Decrease	1	6	Output
1003	N10:3	41004	R	Capacity Increase	1	5	
1004	N10:4	41005	R	Volume Decrease	1	8	
1005	N10:5	41006	R	Volume Increase	1	7	
1014	N10:14	41015	R	Economizer	1	11	Output
1015	N10:15	41016	R	Liquid Injection	1	9	
1020	N10:20	41021	R	Oil Heater	1	21	Output
1024	N10:24	41025	R	Hot Gas Bypass	1	16	Output
1026	N10:26	41027	R	Compressor Motor Start Signal	1	1	Output
1027	N10:27	41028	R	Compressor Motor Starter Feed-back	1	2	Input

**DIGITAL BOARD VALUES: (Continued)**

Frick® Address	AB Address	Modbus Address	Read/Write	Description of Data	Digital Board #	Channel #	Module Type
1028	N10:28	41029	R	Oil Pump Start Signal	1	3	Output
1029	N10:29	41030	R	Oil Pump Feed-back	1	4	Input
1030	N10:30	41031	R	Full Flow Pump/Start Signal	None	0	Output
1032	N10:32	41033	R	Oil Pump #2 Start Signal	2	15	
1033	N10:33	41034	R	Oil Pump #2 Feed-back	2	16	Input
1036	N10:36	41037	R	High Liquid Level Shutdown	1	14	Input
1037	N10:37	41038	R	Regulator Mode A	1	19	
1038	N10:38	41039	R	Regulator Mode B	1	20	
1042	N10:42	41043	R	Shutdown	1	23	Output
1043	N10:43	41044	R	Warning	1	22	
1044	N10:44	41045	R	Balance Piston	1	12	
1045	N10:45	41046	R	Panel Heater	1	15	
1049	N10:49	41050	R	Permissive Start	2	17	Input
1050	N10:50	41051	R	Ready to Run	2	1	Output
1051	N10:51	41052	R	Remote Enabled	2	2	
1052	N10:52	41053	R	Recycle Delay	2	6	
1053	N10:53	41054	R	Remote Start/Stop	2	3	Input
1054	N10:54	41055	R	Remote Load	2	4	
1055	N10:55	41056	R	Remote Unload	2	5	
1056	N10:56	41057	R	Condenser Control Step 1	2	21	Output
1057	N10:57	41058	R	Condenser Control Step 2	2	22	
1058	N10:58	41059	R	Condenser Control Step 3	2	23	
1059	N10:59	41060	R	Condenser Control Step 4	2	24	
1060	N10:60	41061	R	Power Assist	1	24	
1061	N10:61	41062	R	Dx Circuit #1	2	19	Output
1062	N10:62	41063	R	Dx Circuit #2	2	20	
1063	N10:63	41064	R	User Defined Digital Input #1	1	17	Input

**DIGITAL BOARD VALUES: (Continued)**

Frick® Address	AB Address	Modbus Address	Read/Write	Description of Data	Digital Board #	Channel #	Module Type
1064	N10:64	41065	R	User Defined Digital Input #2	1	18	Input
1065	N10:65	41066	R	User Defined Digital Input #3	2	9	
1066	N10:66	41067	R	User Defined Digital Input #4	2	10	
1067	N10:67	41068	R	User Defined Digital Input #5	2	11	
1068	N10:68	41069	R	User Defined Digital Input #6	2	12	
1069	N10:69	41070	R	User Defined Digital Input #7	2	13	
1070	N10:70	41071	R	User Defined Digital Input #8	2	14	
1083	N10:83	41084	R	User Defined Digital Output #1	2	7	Output
1084	N10:84	41085	R	User Defined Digital Output #2	2	8	
1085	N10:85	41086	R	User Defined Digital Output #3	2	18	
1086	N10:86	41087	R	User Defined Digital Output #4	None	0	
1087	N10:87	41088	R	User Defined Digital Output #5	None	0	
1088	N10:88	41089	R	User Defined Digital Output #6	None	0	
1089	N10:89	41090	R	User Defined Digital Output #7	None	0	
1090	N10:90	41091	R	User Defined Digital Output #8	None	0	
1091	N10:91	41092	R	User Defined Digital Output #9	None	0	
1092	N10:92	41093	R	User Defined Digital Output #10	None	0	
1093	N10:93	41094	R	Main Oil Injection	None	0	
1094	N10:94	41095	R	Liquid Level Increase	None	0	
1095	N10:95	41096	R	Liquid Level Decrease	None	0	
1096	N10:96	41097	R	PLC Interlock	None	0	
1097	N10:97	41098	R	High VI Liquid Injection	1	10	

**ANALOG BOARD VALUES:**

Frick® Address	AB Address	Modbus Address	Read/Write	Description of Data	Analog Board #	Channel #	Module Type
2001	N20:1	42002	R	Volume Slide Position	1	15	Input
2002	N20:2	42003	R	Suction Pressure	1	9	
2003	N20:3	42004	R	Discharge Pressure	1	8	
2004	N20:4	42005	R	Oil Pressure (Compressor)	1	6	
2005	N20:5	42006	R	Main Oil Injection Pressure	2	15	
2007	N20:7	42008	R	Filter Pressure	1	7	Input
2009	N20:9	42010	R	Balance Piston Pressure	1	10	Input
2010	N20:10	42011	R	System Discharge Pressure	1	11	
2011	N20:11	42012	R	Suction Temperature	1	1	
2012	N20:12	42013	R	Discharge Temperature	1	2	
2013	N20:13	42014	R	Oil Temperature (Compressor)	1	3	
2014	N20:14	42015	R	Oil Separator Temperature	1	4	
2016	N20:16	42017	R	Process/Brine Temperature Leaving	1	5	Input
2017	N20:17	42018	R	Process/Brine Temperature Entering	2	4	
2026	N20:26	42027	R	Remote Control Setpoint	1	12	Input
2027	N20:27	42028	R	Motor Current	1	16	
2028	N20:28	42029	R	RPM ( <b>NOTE:</b> RPM values are NOT multiplied by 10 in Allen-Bradley and MODBUS protocols)	2	16	
2029	N20:29	42030	R	KW Monitoring	None	0	
2031	N20:31	42032	R	User Defined Analog Input #1	2	5	Input
2032	N20:32	42033	R	User Defined Analog Input #2	2	6	
2033	N20:33	42034	R	User Defined Analog Input #3	2	7	
2034	N20:34	42035	R	User Defined Analog Input #4	2	8	
2035	N20:35	42036	R	User Defined Analog Input #5	2	9	
2036	N20:36	42037	R	User Defined Analog Input #6	2	10	
2037	N20:37	42038	R	User Defined Analog Input #7	2	11	

**ANALOG BOARD VALUES: (Continued)**

Frick® Address	AB Address	Modbus Address	Read/Write	Description of Data	Analog Board #	Channel #	Module Type
2038	N20:38	42039	R	User Defined Analog Input #8	2	12	Input
2039	N20:39	42040	R	User Defined Analog Input #9	2	13	
2040	N20:40	42041	R	User Defined Analog Input #10	2	14	
2041	N20:41	42042	R	User Defined Analog Input #11	1	24	
2051	N20:51	42052	R	PID #1	1	1	Output
2052	N20:52	42053	R	PID #2	1	2	
2053	N20:53	42054	R	PID #3	None	0	
2054	N20:54	42055	R	PID #4	None	0	
2055	N20:55	42056	R	PID #5	None	0	
2056	N20:56	42057	R	PID #6	None	0	
2057	N20:57	42058	R	PID #7	None	0	
2058	N20:58	42059	R	PID #8	None	0	
2059	N20:59	42060	R	Analog Output #1	1	3	
2060	N20:60	42061	R	Analog Output #2	None	0	Output
2061	N20:61	42062	R	Analog Output #3	None	0	
2062	N20:62	42063	R	Analog Output #4	None	0	
2063	N20:63	42064	R	Analog Output #5	None	0	
2064	N20:64	42065	R	Analog Output #6	None	0	
2065	N20:65	42066	R	Analog Output #7	None	0	
2066	N20:66	42067	R	Analog Output #8	None	0	
2067	N20:67	42068	R	Manifold Pressure	2	3	Input
2068	N20:68	42069	R	Remote Capacity Position	1	13	
2069	N20:69	42070	R	Compressor VFD	2	3	Output
2070	N20:70	42071	R	Liquid Level	None	0	Input
2071	N20:71	42072	R	Compressor Vibration - Suction	1	17	
2072	N20:72	42073	R	Compressor Vibration - Discharge	1	18	
2073	N20:73	42074	R	Motor Vibration - Shaft Side	1	19	
2074	N20:74	42075	R	Motor Vibration - Opposite Shaft Side	1	20	

**ANALOG BOARD VALUES: (Continued)**

Frick® Address	AB Address	Modbus Address	Read/Write	Description of Data	Analog Board #	Channel #	Module Type
2075	N20:75	42076	R	Condenser Analog Step #1	1	5	Output
2076	N20:76	42077	R	Condenser Analog Step #2	1	6	
2077	N20:77	42078	R	Motor Temperature - Shaft Side	None	0	Input
2078	N20:78	42079	R	Motor Temperature - Opposite Shaft Side	None	0	
2079	N20:79	42080	R	Motor Stator #1 Temperature	1	21	
2080	N20:80	42081	R	Motor Stator #2 Temperature	1	22	
2081	N20:81	42082	R	Motor Stator #3 Temperature	1	23	
2082	N20:82	42083	R	Superheat Output #1	None	0	
2083	N20:83	42084	R	Superheat Output #2	None	0	
2084	N20:84	42085	R	Superheat Output #3	None	0	
2085	N20:85	42086	R	Analog output #10	None	0	
2086	N20:86	42087	R	Analog output #10	None	0	
2087	N20:87	42088	R	Analog output #11	None	0	
2088	N20:88	42089	R	Analog output #12	None	0	
2089	N20:89	42090	R	Analog output #13	None	0	
2090	N20:90	42091	R	Analog output #14	None	0	
2091	N20:91	42092	R	Analog output #15	None	0	
2092	N20:91	42093	R	Analog output #16	None	0	

**CALCULATED VALUES:**

Frick® Address	AB Address	Modbus Address	Read/Write	Description of Data	Value Code
3000	N30:0	43001	R	Calculated Capacity	Percent (%)
3006	N30:6	43007	R	Filter Differential Pressure	Pressure (Magnitude)
3008	N30:8	43009	R	System Compression Ratio	Percent (%)
3018	N30:18	43019	R	Current Runtime	Hours
3019	N30:19	43020	R	Suction Superheat	Temperature (Magnitude)
3020	N30:20	43021	R	Discharge Superheat	
3021	N30:21	43022	R	Percent of Full Load Amps	Percent (%)
3033	N30:33	43034	R	Volume High End	Volts
3034	N30:34	43035	R	Volume Current Value	
3035	N30:35	43036	R	Volume Low End	
3036	N30:36	43037	R	Capacity High End	
3037	N30:37	43038	R	Capacity Current Value	
3038	N30:38	43039	R	Capacity Low End	
3039	N30:39	43040	R	Calculated Volume Ratio	Real
3058	N30:58	43059	R	Calculated Volume Ratio (Suction)	Real
3059	N30:59	43060	R	Calculated Volume Ration (Economizer)	
3060	N30:60	43061	R	Current Regulation Value	Pressure
3061	N30:61	43062	R	Current Regulation Setpoint	
3062	N30:62	43063	R	Estimated Kilowatts	kW
3063	N30:63	43064	R	Panel Temperature	Temperature
3070	N30:70	43071	R	Safety #1 Message (Most Recent)	Integer
3071	N30:71	43072	R	Safety #2 Message	
3072	N30:72	43073	R	Safety #3 Message	
3073	N30:73	43074	R	Safety #4 Message	
3074	N30:74	43075	R	Safety #5 Message	
3075	N30:75	43076	R	Safety #6 Message	

**Note 1**

**CALCULATED VALUES:**

Frick® Address	AB Address	Modbus Address	Read/Write	Description of Data	Value Code
3076	N30:76	43077	R	Safety #7 Message	
3077	N30:77	43078	R	Safety #8 Message	
3078	N30:78	43079	R	Safety #9 Message	
3079	N30:79	43080	R	Safety #10 Message	
3080	N30:80	43081	R	Total Run Time (Thousands)	
3081	N30:81	43082	R	Total Run Time (Units)	<b>Note 2</b> Real
3102	N31:02	43103	R	Coalescer Filter Differential	Pressure (Magnitude)

**Note 1:** Refer to the chart of *WARNING/SHUTDOWN MESSAGE CODES* on pages 116-121 to determine which message is being displayed.

**Note 2:** To calculate the Total Run Time, use the following equation:

$$\text{Total Run Time (Thousands)} \times 1000 + \text{Total Run Time (Units)} = \text{Total Run Time}$$

**MODE VALUES:**

Frick® Address	AB Address	Modbus Address	Read/Write	Description of Data	Value Codes
4000	N40:0	44001	R	Compressor Status	0 = Off 1 = Running 20 = Starting 30 = Stopping 31 = Stopping - High Capacity 32 = Stopping - Pumpdown 33 = Stopping - Cool Down Period
4001	N40:1	44002	R	Pump Type	0 = No Pump 1 = Full Time 2 = Cycling 3 = Demand 4 = Shaft Auxiliary 5 = Shaft
4002	N40:2	44003	R	Prelube	0 = Not in Prelube 1 = In Prelube
4003	N40:3	44004	R	Postlube	0 = Not in Postlube 1 = In Postlube
4004	N40:4	44005	R	Shutdown	0 = No Shutdowns 1 = Shutdown
4005	N40:5	44006	R	Warning	0 = No Warning 1 = Warning
4006	N40:6	44007	R	Recycle Delay Time	0 = Not In Recycle Delay 1 = In Recycle Delay
4007	N40:7	44008	R	Compressor mode	0 = Manual 1 = Automatic 2 = Remote -- Communications 3 = Remote -- IO 5 = Remote - Sequencing 6 = Manual -- Browser
4008	N40:8	44009	R	Capacity Mode	0 = Manual 1 = Automatic 2 = Remote -- Communications 3 = Remote -- IO 4 = Remote -- 4-20 Input 5 = Remote - Sequencing 6 = Manual -- Browser
4009	N40:9	44010	R	Volume Mode	0 = Manual 1 = Automatic

**MODE VALUES: (Continued)**

Frick® Address	AB Address	Modbus Address	Read/Write	Description of Data	Value Codes
4010	N40:10	44011	R	Compressor Type	0 = RWF 1 = RWBII 2 = RXB 3 = RFX 12-50 4 = RFX 58-101 5 = RDB 4-step 6 = RDB 3-step 7 = GSV II 8 = GST 9 = GSB 3-step 10 = YLC 11 = SC 12 = York S7 13 = York S5 14 = Other Manuf. 15 = Other Manuf (Mycom) 16 = Other Manuf (Kobe) 17 = Recip-0 18 = Recip-1 19 = Recip-2 20 = Recip-3
4014	N40:14	44015	R	Regulation Mode	0 = Regulation 1 1 = Regulation 2 2 = Regulation 3 3 = Regulation 4
4015	N40:15	44016	R	Regulation Mode 1 Direction	0 = Forward 1 = Backward
4016	N40:16	44017	R	Regulation Mode 2 Direction	
4017	N40:17	44018	R	Regulation Mode 3 Direction	
4018	N40:18	44019	R	Regulation Mode 4 Direction	
4019	N40:19	44020	R	Compressor/Drive Type	0 = Screw Comp. with Constant Electric Drive 1 = Screw Compressor with VFD Drive 2 = Screw Compressor with Engine Drive 3 = Screw Compressor with Turbine Drive 4 = Screw Compressor with DBS 5 = Screw Compressor with Vyper 6 = Screw Compressor with Vyper (4-20mA)

**MODE VALUES: (Continued)**

Frick® Address	AB Address	Modbus Address	Read/Write	Description of Data	Value Codes
4022	N40:22	44023	R	Load Inhibit / Force Unload	<p>0 = None            1 = Inhibit-Motor Current            2 = Inhibit-Low Suction Regulation 1            3 = Inhibit-Low Suction Regulation 2            4 = Inhibit-Low Suction Regulation 3            5 = Inhibit-Low Suction Regulation 4            6 = Inhibit-High Discharge Temperature            7 = Inhibit-High Discharge Pressure Mode 1            8 = Inhibit-High Discharge Pressure Mode 2            9 = Inhibit-High Suction Pressure            10 = Inhibit-Low Oil Flow            11 = Inhibit-Separator Velocity            12 = Inhibit-Low RPMs            13 = Inhibit-High Manifold Pressure            14 = Inhibit-Regulation Mode 1            15 = Inhibit-Regulation Mode 2            16 = Inhibit-Regulation Mode 3            17 = Inhibit-Regulation Mode 4            18 = Inhibit-Starting            19 = Inhibit-Capacity Pulldown            20 = Inhibit-At Maximum Load            21 = Inhibit-Vyper Converter Heatsink Temperature            22 = Inhibit-Vyper Ambient Temperature            23 = Inhibit-Harmonic Filter Baseplate Temperature            24 = Inhibit-Vyper Baseplate Temperature            25 = Inhibit-Vyper Phase A Baseplate Temperature            26 = Inhibit-Vyper Phase B Baseplate Temperature            27 = Inhibit-Vyper Phase C Baseplate Temperature            28 = Inhibit - Low Proc. Leaving Temp.            29 = Inhibit - Low Engine JW Temperature            30 = Inhibit - Maximum Capacity Position            31 = Inhibit - Minimum Capacity Position</p> <p>50 = Force Unload-Volume Increase            51 = Force Unload-Motor Current            52 = Force Unload-Low Suction Regulation 1            53 = Force Unload-Low Suction Regulation 2            54 = Force Unload-Low Suction Regulation 3            55 = Force Unload-Low Suction Regulation 4            56 = Force Unload-Regulation Mode 1            57 = Force Unload-Regulation Mode 2            58 = Force Unload-Regulation Mode 3            59 = Force Unload-Regulation Mode 4            60 = Force Unload-High Discharge Temperature            61 = Force Unload-High Discharge Pressure Mode 1            62 = Force Unload-High Discharge Pressure Mode 2            63 = Force Unload-High Suction Pressure            64 = Force Unload-Low Oil Flow            65 = Force Unload-Separator Velocity            66 = Force Unload-Low RPMs            67 = Force Unload-High Manifold Pressure            68 = Force Unload-Stopping            69 = Force Unload-Vyper Converter Heatsink Temp.            70 = Force Unload-Vyper Ambient Temp.            71 = Force Unload-Harmonic Filter Baseplate Temp.            72 = Force Unload-Vyper Baseplate Temp.            73 = Force Unload-Vyper Phase A Baseplate Temp.            74 = Force Unload-Vyper Phase B Baseplate Temp.            75 = Force Unload-Vyper Phase C Baseplate Temp.            76 = Unload - Low Proc. Leaving Temp.            77 = Force Unload - Maximum Capacity Position            78 = Force Unload - Minimum Capacity Position</p>

**MODE VALUES: (Continued)**

Frick® Address	AB Address	Modbus Address	Read/Write	Description of Data	Value Codes
4027	N40:27	44028	R	Condenser Enabled	0 = Disabled 1 = Running 2 = Always
4070	N40:70	44071	R	Compressor Start Status	0 = Ready 1 = Start Inhibit In Shutdown 2 = Start Inhibit In Recycle Delay 3 = Start Inhibit High Discharge Temperature 4 = Start Inhibit High Oil Temperature 5 = Start Inhibit Low Separator Temperature 6 = Start Inhibit Slide Valve Too High 7 = Start Inhibit Still In Prelube 8 = Start Inhibit High Suction Pressure 9 = Start Inhibit High Suction/Discharge Differential 10 = Start Inhibit Permissive Start 11 = Start Inhibit Digital Auxiliaries 12 = Power Fail Restart 13 = Start Inhibit Low Oil Pressure 14 = Running 15 = Start Inhibit In Discharge Pressure Blowdown
4071	N40:71	44072	R	Capacity Status	0 = Idle 1 = Load 2 = Unload
4072	N40:72	44073	R	Volume Status	0 = Idle 1 = Increase 2 = Decrease
4073	N40:73	44074	R	Language (Local Display Only)	0 = English 1 = French 2 = Chinese 3 = Portuguese 4 = Polish 5 = Chinese 6 = Spanish 7 = Russian 8 = Italian
4074	N40:74	44075	R	Temperature Units (Local Display Only)	0 = Celsius 1 = Fahrenheit
4075	N40:75	44076	R	Pressure Units (Local Display Only)	0 = Kpa 1 = Bar 2 = BarA 3 = PSIA 4 = PSIG/hg 5 = kpaG
4077	N40:77	44078	R	Regulation Mode 1	0 = Disabled 1 = Enabled
4078	N40:78	44079	R	Regulation Mode 2	
4079	N40:79	44080	R	Regulation Mode 3	
4080	N40:80	44081	R	Regulation Mode 4	
4081	N40:81	44082	R	Sequencing Control Enable	

**MODE VALUES: (Continued)**

Frick® Address	AB Address	Modbus Address	Read/Write	Description of Data	Value Codes
4199	N41:99	44200	R	Manual Capacity Load/Unload	0 = Idle 1 = Load 2 = Unload
4200	N42:00	44201	R	Alarm Silence	0 = Off 1 = On
4201	N42:01	44202	R	Manual Compressor Action	-1 = Idle 0 = Stop 1 = Run
4234	N42:34	44235	R	Refrigerant	1 = R11                    19 = R404a 2 = R113                   20 = R410a 3 = R114                   21 = R50 4 = R1150                  22 = R500 5 = R12                     23 = R502 6 = R1270                  24 = R503 7 = R13                     25 = R507 8 = R134a                  26 = R508 9 = R13b1                  27 = R508b 10 = R14                    28 = R600 11 = R142b                 29 = R600a 12 = R170                   30 = R717 13 = R218                   31 = R718 14 = R22                    32 = R728 15 = R23                    33 = R729 16 = R290                   34 = R744 17 = R401a                 35 = R771 18 = R402a                 50 = User Defined
4237	N42:37	44238	R	Oil Pump Status	0 = Off 1 = Running
4239	N42:39	44240	R	PID 1 Control	0 = Disabled 1 = Running 2 = Always
4242	N42:42	44243	R	PID 2 Control	0 = Disabled 1 = Running 2 = Always
4245	N42:45	44246	R	PID 3 Control	0 = Disabled 1 = Running 2 = Always
4248	N42:48	44249	R	PID 4 Control	0 = Disabled 1 = Running 2 = Always
4251	N42:51	44252	R	PID 5 Control	0 = Disabled 1 = Running 2 = Always
4254	N42:54	44255	R	PID 6 Control	0 = Disabled 1 = Running 2 = Always

**MODE VALUES: (Continued)**

Frick® Address	AB Address	Modbus Address	Read/Write	Description of Data	Value Codes
4257	N42:57	44258	R	PID 7 Control	0 = Disabled 1 = Running 2 = Always
4260	N42:60	44261	R	PID 8 Control	0 = Disabled 1 = Running 2 = Always
4383	N43:83	44384	R	Sequencing – Sys. 1 Comp 1 Comp Mode	0 = Manual 1 = Automatic 2 = Remote -- Communications 3 = Remote -- IO 5 = Remote -- Sequencing
4384	N43:84	44385	R	Sequencing – Sys. 1 Comp 2 Comp Mode	
4385	N43:85	44386	R	Sequencing – Sys. 1 Comp 3 Comp Mode	
4386	N43:86	44387	R	Sequencing – Sys. 1 Comp 4 Comp Mode	
4387	N43:87	44388	R	Sequencing – Sys. 1 Comp 5 Comp Mode	
4388	N43:88	44389	R	Sequencing – Sys. 1 Comp 6 Comp Mode	
4389	N43:89	44390	R	Sequencing – Sys. 1 Comp 7 Comp Mode	
4390	N43:90	44391	R	Sequencing – Sys. 1 Comp 8 Comp Mode	
4391	N43:91	44392	R	Sequencing – Sys. 1 Comp 1 Capacity Mode	0 = Manual 1 = Automatic 2 = Remote -- Communications 3 = Remote -- IO 4 = Remote -- 4-20 Input 5 = Remote -- Sequencing
4392	N43:92	44393	R	Sequencing – Sys. 1 Comp 2 Capacity Mode	
4393	N43:93	44394	R	Sequencing – Sys. 1 Comp 3 Capacity Mode	
4394	N43:94	44395	R	Sequencing – Sys. 1 Comp 4 Capacity Mode	
4395	N43:95	44396	R	Sequencing – Sys. 1 Comp 5 Capacity Mode	
4396	N43:96	44397	R	Sequencing – Sys. 1 Comp 6 Capacity Mode	
4397	N43:97	44398	R	Sequencing – Sys. 1 Comp 7 Capacity Mode	
4398	N43:98	44399	R	Sequencing – Sys. 1 Comp 8 Capacity Mode	
4407	N44:07	44408	R	Sequencing Enable - System 1	0 = Disabled 1 = Enabled
4417	N44:17	44418	R	Sequencing - Sys 1 Comp 1 Comp Status	0 = Off 1 = Running 20 = Starting 30 = Stopping 31 = Stopping - High Capacity 32 = Stopping - Pumpdown
4418	N44:18	44419	R	Sequencing - Sys 1 Comp 2 Comp Status	
4419	N44:19	44420	R	Sequencing - Sys 1 Comp 3 Comp Status	
4420	N44:20	44421	R	Sequencing - Sys 1 Comp 4 Comp Status	
4421	N44:21	44422	R	Sequencing - Sys 1 Comp 5 Comp Status	
4422	N44:22	44423	R	Sequencing - Sys 1 Comp 6 Comp Status	
4423	N44:23	44424	R	Sequencing - Sys 1 Comp 7 Comp Status	
4424	N44:24	44425	R	Sequencing - Sys 1 Comp 8 Comp Status	
4433	N44:33	44434	R	Sequencing – Sys. 2 Comp 1 Comp Mode	0 = Manual 1 = Automatic 2 = Remote -- Communications 3 = Remote -- IO 5 = Remote -- Sequencing
4434	N44:34	44435	R	Sequencing – Sys. 2 Comp 2 Comp Mode	
4435	N44:35	44436	R	Sequencing – Sys. 2 Comp 3 Comp Mode	
4436	N44:36	44437	R	Sequencing – Sys. 2 Comp 4 Comp Mode	
4437	N44:37	44438	R	Sequencing – Sys. 2 Comp 5 Comp Mode	
4438	N44:38	44439	R	Sequencing – Sys. 2 Comp 6 Comp Mode	
4439	N44:39	44440	R	Sequencing – Sys. 2 Comp 7 Comp Mode	
4440	N44:40	44441	R	Sequencing – Sys. 2 Comp 8 Comp Mode	

**MODE VALUES: (Continued)**

Frick® Address	AB Address	Modbus Address	Read/Write	Description of Data	Value Codes
4441	N44:41	44442	R	Sequencing – Sys. 2 Comp 1 Capacity Mode	0 = Manual 1 = Automatic 2 = Remote - Communications 3 = Remote - IO 4 = Remote - 4-20 Input 5 = Remote - Sequencing
4442	N44:42	44443	R	Sequencing – Sys. 2 Comp 2 Capacity Mode	
4443	N44:43	44444	R	Sequencing – Sys. 2 Comp 3 Capacity Mode	
4444	N44:44	44445	R	Sequencing – Sys. 2 Comp 4 Capacity Mode	
4445	N44:45	44446	R	Sequencing – Sys. 2 Comp 5 Capacity Mode	
4446	N44:46	44447	R	Sequencing – Sys. 2 Comp 6 Capacity Mode	
4447	N44:47	44448	R	Sequencing – Sys. 2 Comp 7 Capacity Mode	
4448	N44:48	44449	R	Sequencing – Sys. 2 Comp 8 Capacity Mode	
4457	N44:57	44458	R	Sequencing Enable - System 2	0 = Disabled 1 = Enabled
4467	N44:67	44468	R	Sequencing – Sys. 2 Comp 1 Comp Status	0 = Off 1 = Running 20 = Starting 30 = Stopping 31 = Stopping - High Capacity 32 = Stopping - Pumpdown
4468	N44:68	44469	R	Sequencing – Sys. 2 Comp 2 Comp Status	
4469	N44:69	44470	R	Sequencing – Sys. 2 Comp 3 Comp Status	
4470	N44:70	44471	R	Sequencing – Sys. 2 Comp 4 Comp Status	
4471	N44:71	44472	R	Sequencing – Sys. 2 Comp 5 Comp Status	
4472	N44:72	44473	R	Sequencing – Sys. 2 Comp 6 Comp Status	
4473	N44:73	44474	R	Sequencing – Sys. 2 Comp 7 Comp Status	
4474	N44:74	44475	R	Sequencing – Sys 2 Comp 8 Comp Status	
4483	N44:83	44484	R	Sequencing – Sys. 3 Comp 1 Comp Mode	0 = Manual 1 = Automatic 2 = Remote - Communications 3 = Remote - IO 5 = Remote - Sequencing
4484	N44:84	44485	R	Sequencing – Sys. 3 Comp 2 Comp Mode	
4485	N44:85	44486	R	Sequencing – Sys. 3 Comp 3 Comp Mode	
4486	N44:86	44487	R	Sequencing – Sys. 3 Comp 4 Comp Mode	
4487	N44:87	44488	R	Sequencing – Sys. 3 Comp 5 Comp Mode	
4488	N44:88	44489	R	Sequencing – Sys. 3 Comp 6 Comp Mode	
4489	N44:89	44490	R	Sequencing – Sys. 3 Comp 7 Comp Mode	
4490	N44:90	44491	R	Sequencing – Sys. 3 Comp 8 Comp Mode	
4491	N44:91	44492	R	Sequencing – Sys. 3 Comp 1 Capacity Mode	0 = Manual 1 = Automatic 2 = Remote - Communications 3 = Remote - IO 4 = Remote - 4-20 Input 5 = Remote - Sequencing
4492	N44:92	44493	R	Sequencing – Sys. 3 Comp 2 Capacity Mode	
4493	N44:93	44494	R	Sequencing – Sys. 3 Comp 3 Capacity Mode	
4494	N44:94	44495	R	Sequencing – Sys. 3 Comp 4 Capacity Mode	
4495	N44:95	44496	R	Sequencing – Sys. 3 Comp 5 Capacity Mode	
4496	N44:96	44497	R	Sequencing – Sys. 3 Comp 6 Capacity Mode	
4497	N44:97	44498	R	Sequencing – Sys. 3 Comp 7 Capacity Mode	
4498	N44:98	44499	R	Sequencing – Sys. 3 Comp 8 Capacity Mode	
4507	N45:07	44508	R	Sequencing Enable - System 3	0 = Disabled 1 = Enabled

**MODE VALUES: (Read Only) Continued**

Frick® Address	AB Address	Modbus Address	Read/Write	Description of Data	Value Codes
4517	N45:17	44518	R	Sequencing – Sys. 3 Comp 1 Comp Status	0 = Off 1 = Running 20 = Starting 30 = Stopping 31 = Stopping - High Capacity 32 = Stopping - Pumpdown
4518	N45:18	44519	R	Sequencing – Sys. 3 Comp 2 Comp Status	
4519	N45:19	44520	R	Sequencing – Sys. 3 Comp 3 Comp Status	
4520	N45:20	44521	R	Sequencing – Sys. 3 Comp 4 Comp Status	
4521	N45:21	44522	R	Sequencing – Sys. 3 Comp 5 Comp Status	
4522	N45:22	44523	R	Sequencing – Sys. 3 Comp 6 Comp Status	
4523	N45:23	44524	R	Sequencing – Sys. 3 Comp 7 Comp Status	
4524	N45:24	44525	R	Sequencing – Sys. 3 Comp 8 Comp Status	
4533	N45:33	44534	R	Oil Pump Mode	0 = Manual 1 = Automatic
4534	N45:34	44535	R	Screen Saver	0 = Disabled 1 = Enabled
4539	N45:39	44540	R	Starter Alarms	
4540	N45:40	44541	R	Starter Trips	
4547	N45:47	44548	R	Input Module Capacity Mode Selection	0 = Disabled 1 = Enabled
4548	N45:48	44549	R	Permissive Start Enable	0 = Disabled 1 = Starting 2 = Always
4549	N45:49	44550	R	PLC Interlock Enable	0 = Disabled 1 = Enabled
4550	N45:50	44551	R	Remote Enable Output	0 = Disabled 1 = Compressor Mode: Remote I/O 2 = Compressor Mode: Remote I/O and Capacity Mode: Remote I/O 3 = Compressor Mode: Remote I/O and Capacity Mode: Remote 4-20
4551	N45:51	44552	R	Oil Log Mode	0 = Disabled 1 = Enabled
4566	N45:66	44567	R	Communications Unit Flag	0 = Celsius / PSIA 1 = Panel Units

**TIMER VALUES: (Read Only)**

Frick® Address	AB Address	Modbus Address	Read/Write	Description of Data
6000	N60:00	46001	R	Pre-Lube Timer
6001	N60:01	46002	R	Post-lube Timer
6002	N60:02	46003	R	Stopping Unload Timer
6003	N60:03	46004	R	Volume Control Timer
6004	N60:04	46005	R	Capacity Control Timer
6006	N60:06	46007	R	Capacity Load Time
6007	N60:07	46008	R	Capacity Unload Time
6008	N60:08	46009	R	General 10 Second Timer
6009	N60:09	46010	R	Step Load Inhibit Time
6010	N60:10	46011	R	Step Unload Delay Time
6011	N60:11	46012	R	Drive Output Timer
6012	N60:12	46013	R	Autocycle Start Timer
6013	N60:13	46014	R	Autocycle Stop Timer
6014	N60:14	46015	R	Condenser Step Timer
6015	N60:15	46016	R	Balance Piston Ignore
6016	N60:16	46017	R	Stopping Pumpdown Timer
6017	N60:17	46018	R	Liquid Injection Timer
6018	N60:18	46019	R	Liquid Level Timer
6019	N60:19	46020	R	Oil Injection Timer
6020	N60:20	46021	R	Starting Load Inhibit Timer
6021	N60:21	46022	R	Capacity Pulldown Timer
6022	N60:22	46023	R	General 60 Second Timer
6023	N60:23	46024	R	Recycle Delay Timer
6024	N60:24	46025	R	Oil Charging Timer
6025	N60:25	46026	R	Differential Pressure OK Timer
6026	N60:26	46027	R	Slide to Zero Timer
6027	N60:27	46028	R	General 1 Second Timer
6028	N60:28	46029	R	Capacity/Volume Calibration Timer
6029	N60:29	46030	R	Dual Pump Transition Timer
6030	N60:30	46031	R	Power Assist Timer
6031	N60:31	46032	R	Power Fail Restart Timer
6032	N60:32	46033	R	PLC Interlock Timer
6036	N60:36	46037	R	Motor Amps Ignore
6037	N60:37	46038	R	Remote I/O Start Stop
6038	N60:38	46039	R	Vyper Standby Timer
6039	N60:39	46040	R	Drive Force Unload Timer
6040	N60:40	46041	R	Vyper Clear Standby Timer
6041	N60:41	46042	R	Min Slide Valve Timer
6042	N60:42	46043	R	Force Unload Step Timer
6043	N60:43	46044	R	Safety Unload Delay Timer
6044	N60:44	46045	R	Step Volume Timer
6045	N60:45	46046	R	Sequencing Disable Timer
6046	N60:46	46047	R	Shutdown Unload Timer

**SETPOINT VALUES:**

Frick® Address	AB Address	Modbus Address	Read/Write	Description of Data	Units
7060	N100:60	47061	R/W	Screen Saver Delay Setpoint	Minutes
7061	N100:61	47062	R/W	Atmospheric Pressure	Pressure (Magnitude)
7100	N101:00	47101	R/W	K Factor	Real
7102	N101:02	47103	R/W	Unload Delay When Stopping	Seconds
7103	N101:03	47104	R/W	Hot Gas On When Below	Percent (%)
7104	N101:04	47105	R/W	False Running Compressor Input Delay	Seconds
7120	N101:20	47121	R/W	Power Assist	Seconds
7121	N101:21	47122	R/W	Power Failure Restart Delay	Minutes
7123	N101:23	47124	R/W	Panel Heater On Value	Temperature
7124	N101:24	47125	R/W	Panel Heater Off Value	
7125	N101:25	47126	R/W	Permissive Start Shutdown Delay	Seconds
7126	N101:26	47127	R/W	PLC Interlock Delay	
7150	N101:50	47151	R/W	Regulation Mode 1 Setpoint	Pressure
7152	N101:52	47153	R/W	Regulation Mode 1 High Dead Band	Pressure (Magnitude)
7153	N101:53	47154	R/W	Regulation Mode 1 Low Dead Band	
7154	N101:54	47155	R/W	Regulation Mode 1 High Proportional Band	
7155	N101:55	47156	R/W	Regulation Mode 1 Low Proportional Band	
7156	N101:56	47157	R/W	Regulation Mode 1 High Cycle Time	Seconds
7157	N101:57	47158	R/W	Regulation Mode 1 Low Cycle Time	
7158	N101:58	47159	R/W	Regulation Mode 1 Auto Cycle Start	Pressure
7159	N101:59	47160	R/W	Regulation Mode 1 Auto Cycle Start Delay	Minutes
7160	N101:60	47161	R/W	Regulation Mode 1 Auto Cycle Stop	Pressure
7161	N101:61	47162	R/W	Regulation Mode 1 Auto Cycle Stop Delay	Minutes
7162	N101:62	47163	R/W	Regulation Mode 1 Load Inhibit	Pressure
7163	N101:63	47164	R/W	Regulation Mode 1 Force Unload	
7164	N101:64	47165	R/W	Regulation Mode 1 Shutdown	
7165	N101:65	47166	R/W	Regulation Mode 1 Warning	
7166	N101:66	47167	R/W	Regulation Mode 1 Shutdown Delay	Seconds
7167	N101:67	47168	R/W	Regulation Mode 1 Warning Delay	
7168	N101:68	47169	R/W	Low Suction Pressure Shutdown Mode 1	Pressure
7169	N101:69	47170	R/W	Low Suction Pressure Shutdown Mode 1 Delay	Seconds
7170	N101:70	47171	R/W	Low Suction Pressure Warning Mode 1	Pressure
7171	N101:71	47172	R/W	Low Suction Pressure Warning Mode 1 Delay	Seconds
7172	N101:72	47173	R/W	Low Suction Pressure Mode 1 Load Inhibit	Pressure
7173	N101:73	47174	R/W	Low Suction Pressure Mode 1 Force Unload	
7176	N101:76	47177	R/W	Mode 1 Prop Band	Pressure
7177	N101:77	47178	R/W	Mode 1 Integration Time	Seconds
7200	N102:00	47201	R/W	Regulation Mode 2 Setpoint	Temperature
7202	N102:02	47203	R/W	Regulation Mode 2 High Dead Band	Temperature (Magnitude)
7203	N102:03	47204	R/W	Regulation Mode 2 Low Dead Band	

**SETPOINT VALUES: (Continued)**

Frick® Address	AB Address	Modbus Address	Read/Write	Description of Data	Units
7204	N102:04	47205	R/W	Regulation Mode 2 High Proportional Band	Temperature (Magnitude)
7205	N102:05	47206	R/W	Regulation Mode 2 Low Proportional Band	
7206	N102:06	47207	R/W	Regulation Mode 2 High Cycle Time	Seconds
7207	N102:07	47208	R/W	Regulation Mode 2 Low Cycle Time	
7208	N102:08	47209	R/W	Regulation Mode 2 Auto Cycle Start	Temperature
7209	N102:09	47210	R/W	Regulation Mode 2 Auto Cycle Start Delay	Minutes
7210	N102:10	47211	R/W	Regulation Mode 2 Auto Cycle Stop	Temperature
7211	N102:11	47212	R/W	Regulation Mode 2 Auto Cycle Stop Delay	Minutes
7212	N102:12	47213	R/W	Regulation Mode 2 Load Inhibit	Temperature
7213	N102:13	47214	R/W	Regulation Mode 2 Force Unload	
7214	N102:14	47215	R/W	Regulation Mode 2 Shutdown	
7215	N102:15	47216	R/W	Regulation Mode 2 Warning	
7216	N102:16	47217	R/W	Regulation Mode 2 Shutdown Delay	
7217	N102:17	47218	R/W	Regulation Mode 2 Warning Delay	Seconds
7218	N102:18	47219	R/W	Low Suction Pressure Shutdown Mode 2	Pressure
7219	N102:19	47220	R/W	Low Suction Pressure Shutdown Mode 2 Delay	Seconds
7220	N102:20	47221	R/W	Low Suction Pressure Warning Mode 2	Pressure
7221	N102:21	47222	R/W	Low Suction Pressure Warning Mode 2 Delay	Seconds
7222	N102:22	47223	R/W	Low Suction Pressure Mode 2 Load Inhibit	Pressure
7223	N102:23	47224	R/W	Low Suction Pressure Mode 2 Force Unload	
7226	N102:26	47227	R/W	Mode 2 Prop Band	Pressure
7227	N102:27	47228	R/W	Mode 2 Integration Time	Seconds
7250	N102:50	47251	R/W	Regulation Mode 3 Setpoint	Pressure
7252	N102:52	47253	R/W	Regulation Mode 3 High Dead Band	Pressure (Magnitude)
7253	N102:53	47254	R/W	Regulation Mode 3 Low Dead Band	
7254	N102:54	47255	R/W	Regulation Mode 3 High Proportional Band	
7255	N102:55	47256	R/W	Regulation Mode 3 Low Proportional Band	
7256	N102:56	47257	R/W	Regulation Mode 3 High Cycle Time	
7257	N102:57	47258	R/W	Regulation Mode 3 Low Cycle Time	Seconds
7258	N102:58	47259	R/W	Regulation Mode 3 Auto Cycle Start	Pressure
7259	N102:59	47260	R/W	Regulation Mode 3 Auto Cycle Start Delay	Minutes
7260	N102:60	47261	R/W	Regulation Mode 3 Auto Cycle Stop	Pressure
7261	N102:61	47262	R/W	Regulation Mode 3 Auto Cycle Stop Delay	Minutes
7262	N102:62	47263	R/W	Regulation Mode 3 Load Inhibit	Pressure
7263	N102:63	47264	R/W	Regulation Mode 3 Force Unload	
7264	N102:64	47265	R/W	Regulation Mode 3 Shutdown	
7265	N102:65	47266	R/W	Regulation Mode 3 Warning	
7266	N102:66	47267	R/W	Regulation Mode 3 Shutdown Delay	Seconds
7267	N102:67	47268	R/W	Regulation Mode 3 Warning Delay	
7268	N102:68	47269	R/W	Low Suction Pressure Shutdown Mode 3	Pressure
7269	N102:69	47270	R/W	Low Suction Pressure Shutdown Mode 3 Delay	Seconds
7270	N102:70	47271	R/W	Low Suction Pressure Warning Mode 3	Pressure
7271	N102:71	47272	R/W	Low Suction Pressure Warning Mode 3 Delay	Seconds
7272	N102:72	47273	R/W	Low Suction Pressure Mode 3 Load Inhibit	Pressure
7273	N102:73	47274	R/W	Low Suction Pressure Mode 3 Force Unload	
7276	N102:76	47277	R/W	Mode 3 Prop Band	Pressure

**SETPOINT VALUES: (Continued)**

Frick® Address	AB Address	Modbus Address	Read/Write	Description of Data	Units
7277	N102:77	47278	R/W	Mode 3 Integration Time	Seconds
7300	N103:00	47301	R/W	Regulation Mode 4 Setpoint	Pressure
7302	N103:02	47303	R/W	Regulation Mode 4 High Dead Band	Pressure (Magnitude)
7303	N103:03	47304	R/W	Regulation Mode 4 Low Dead Band	
7304	N103:04	47305	R/W	Regulation Mode 4 High Proportional Band	
7305	N103:05	47306	R/W	Regulation Mode 4 Low Proportional Band	
7306	N103:06	47307	R/W	Regulation Mode 4 High Cycle Time	Seconds
7307	N103:07	47308	R/W	Regulation Mode 4 Low Cycle Time	Pressure
7308	N103:08	47309	R/W	Regulation Mode 4 Auto Cycle Start	Minutes
7309	N103:09	47310	R/W	Regulation Mode 4 Auto Cycle Start Delay	Pressure
7310	N103:10	47311	R/W	Regulation Mode 4 Auto Cycle Stop	Minutes
7311	N103:11	47312	R/W	Regulation Mode 4 Auto Cycle Stop Delay	Pressure
7312	N103:12	47313	R/W	Regulation Mode 4 Load Inhibit	
7313	N103:13	47314	R/W	Regulation Mode 4 Force Unload	
7314	N103:14	47315	R/W	Regulation Mode 4 Shutdown	
7315	N103:15	47316	R/W	Regulation Mode 4 Warning	
7316	N103:16	47317	R/W	Regulation Mode 4 Shutdown Delay	Seconds
7317	N103:17	47318	R/W	Regulation Mode 4 Warning Delay	Pressure
7318	N103:18	47319	R/W	Low Suction Pressure Shutdown Mode 4	Seconds
7319	N103:19	47320	R/W	Low Suction Pressure Shutdown Mode 4 Delay	Pressure
7320	N103:20	47321	R/W	Low Suction Pressure Warning Mode 4	Seconds
7321	N103:21	47322	R/W	Low Suction Pressure Warning Mode 4 Delay	Pressure
7322	N103:22	47323	R/W	Low Suction Pressure Mode 4 Load Inhibit	Pressure
7323	N103:23	47324	R/W	Low Suction Pressure Mode 4 Force Unload	
7326	N103:26	47327	R/W	Mode 4 Prop Band	Pressure
7327	N103:27	47328	R/W	Mode 4 Integration Time	Seconds
7350	N103:50	47351	R/W	High Motor Current Load Inhibit	Amps
7351	N103:51	47352	R/W	High Motor Current Force Unload	
7352	N103:52	47353	R/W	High Motor Current Shutdown	
7353	N103:53	47354	R/W	High Motor Current Warning	
7354	N103:54	47355	R/W	High Motor Current Shutdown Delay	Seconds
7355	N103:55	47356	R/W	High Motor Current Warning Delay	Amps
7356	N103:56	47357	R/W	Low Motor Current Shutdown	Seconds
7357	N103:57	47358	R/W	Low Motor Current Shutdown Delay	Amps
7358	N103:58	47359	R/W	Motor Current Confirmed Running	Seconds
7359	N103:59	47360	R/W	False Running Motor Amps Delay	Amps
7360	N103:60	47361	R/W	Starting Motor Amps Ignore Period	
7361	N103:61	47362	R/W	Name Plate Motor Amps	Integer
7362	N103:62	47363	R/W	Volts	Real
7363	N103:63	47364	R/W	Service Factor	Integer
7364	N103:64	47365	R/W	Horsepower	Minutes
7365	N103:65	47366	R/W	Recycle Delay	None
7366	N103:66	47367	R/W	CT Factor	Seconds
7373	N103:73	47374	R/W	Drive Increase Cycle Time	Percent (%)
7374	N103:74	47375	R/W	Drive Increase Rate Of Change	
7375	N103:75	47376	R/W	Drive Idle	

**SETPOINT VALUES: (Continued)**

Frick® Address	AB Address	Modbus Address	Read/Write	Description of Data	Units
7376	N103:76	47377	R/W	Drive Minimum	Percent (%)
7377	N103:77	47378	R/W	Drive Maximum	
7378	N103:78	47379	R/W	Drive Decrease Cycle Time	Seconds
7379	N103:79	47380	R/W	Drive Decrease Rate Of Change	Percent (%)
7380	N103:80	47381	R/W	Proportional Drive Speed Maximum	
7381	N103:81	47382	R/W	Proportional Slide Valve Maximum	
7382	N103:82	47383	R/W	Low RPMs Shutdown	(NOTE: RPM values are NOT multiplied by 10 in Allen-Bradley and MODBUS protocols)
7383	N103:83	47384	R/W	Low RPMs Warning	
7384	N103:84	47385	R/W	Low RPMs Load Inhibit	
7385	N103:85	47386	R/W	Low RPMs Force Unload	
7386	N103:86	47387	R/W	Low RPMs Shutdown Delay	Seconds
7387	N103:87	47388	R/W	Low RPMs Warning Delay	
7388	N103:88	47389	R/W	High RPMs Shutdown	(NOTE: RPM values are NOT multiplied by 10 in Allen-Bradley and MODBUS protocols)
7389	N103:89	47390	R/W	High RPMs Warning	
7390	N103:90	47391	R/W	High RPMs Shutdown Delay	Seconds
7391	N103:91	47392	R/W	High RPMs Warning Delay	
7392	N103:92	47393	R/W	Low Manifold Pressure Load Inhibit	Pressure
7393	N103:93	47394	R/W	Low Manifold Pressure Force Unload	
7394	N103:94	47395	R/W	Low Manifold Pressure Shutdown	
7395	N103:95	47396	R/W	Low Manifold Pressure Warning	
7396	N103:96	47397	R/W	Low Manifold Pressure Shutdown Delay	Seconds
7397	N103:97	47398	R/W	Low Manifold Pressure Warning Delay	
7398	N103:98	47399	R/W	RPM Confirmed Running Shutdown Delay	Minutes
7399	N103:99	47400	R/W	RPM Confirmed Running	(NOTE: RPM values are NOT multiplied by 10 in Allen-Bradley and MODBUS protocols)
7400	N104:00	47401	R/W	Highest Capacity Position For Starting	Percent (%)
7401	N104:01	47402	R/W	Capacity Slide Stroke	Real
7402	N104:02	47403	R/W	Capacity Decrease Assist Rate	Percent (%)
7403	N104:03	47404	R/W	Remote Capacity 4_20 Deadband	
7404	N104:04	47405	R/W	Automatic Capacity Mode Minimum Slide Valve Position	
7405	N104:05	47406	R/W	Minimum Capacity Pulse Time	Seconds
7406	N104:06	47407	R/W	Step Force Unload Load Inhibit Period	
7407	N104:07	47408	R/W	Starting Load Inhibit Period	
7408	N104:08	47409	R/W	Capacity Position For Volume Increase Force Unload	Percent (%)
7409	N104:09	47410	R/W	Recip Step Count	Integer
7410	N104:10	47411	R/W	Capacity Top End (Calibration)	
7411	N104:11	47312	R/W	Capacity Bottom End (Calibration)	
7413	N104:13	47414	R/W	Volume Top End	Real
7414	N104:14	47415	R/W	Volume Bottom End	
7415	N104:15	47416	R/W	Volume Middle	
7416	N104:16	47417	R/W	Volume Deadband	
7417	N104:17	47418	R/W	Volume Pulse Time	Integer
7418	N104:18	47419	R/W	Volume Top End (Calibration)	
7419	N104:19	47420	R/W	Volume Bottom End (Calibration)	
7423	N104:23	47424	R/W	Drive Proportional Band	Seconds
7424	N104:24	47425	R/W	Drive Integration Time	

**SETPOINT VALUES: (Continued)**

Frick® Address	AB Address	Modbus Address	Read/Write	Description of Data	Units
7425	N104:25	47426	R/W	Time Schedule Sunday 1st Mode Hour 1	Integer
7426	N104:26	47427	R/W	Time Schedule Sunday 1st Mode Minute 1	
7427	N104:27	47428	R/W	Time Schedule Sunday 2nd Mode Hour 2	
7428	N104:28	47429	R/W	Time Schedule Sunday 2nd Mode Minute 2	
7429	N104:29	47430	R/W	Time Schedule Sunday 3rd Mode Hour 1	
7430	N104:30	47431	R/W	Time Schedule Sunday 3rd Mode Minute 1	
7431	N104:31	47432	R/W	Time Schedule Sunday 4th Mode Hour 2	
7432	N104:32	47433	R/W	Time Schedule Sunday 4th Mode Minute 2	
7433	N104:33	47434	R/W	Time Schedule Monday 1st Mode Hour 1	
7434	N104:34	47435	R/W	Time Schedule Monday 1st Mode Minute 1	
7435	N104:35	47436	R/W	Time Schedule Monday 2nd Mode Hour 2	
7436	N104:36	47437	R/W	Time Schedule Monday 2nd Mode Minute 2	
7437	N104:37	47438	R/W	Time Schedule Monday 3rd Mode Hour 1	
7438	N104:38	47439	R/W	Time Schedule Monday 3rd Mode Minute 1	
7439	N104:39	47440	R/W	Time Schedule Monday 4th Mode Hour 2	
7440	N104:40	47441	R/W	Time Schedule Monday 4th Mode Minute 2	
7441	N104:41	47442	R/W	Time Schedule Tuesday 1st Mode Hour 1	
7442	N104:42	47443	R/W	Time Schedule Tuesday 1st Mode Minute 1	
7443	N104:43	47444	R/W	Time Schedule Tuesday 2nd Mode Hour 2	
7444	N104:44	47445	R/W	Time Schedule Tuesday 2nd Mode Minute 2	
7445	N104:45	47446	R/W	Time Schedule Tuesday 3rd Mode Hour 1	
7446	N104:46	47447	R/W	Time Schedule Tuesday 3rd Mode Minute 1	
7447	N104:47	47448	R/W	Time Schedule Tuesday 4th Mode Hour 2	
7448	N104:48	47449	R/W	Time Schedule Tuesday 4th Mode Minute 2	
7449	N104:49	47450	R/W	Time Schedule Wednesday 1st Mode Hour 1	
7450	N104:50	47451	R/W	Time Schedule Wednesday 1st Mode Minute 1	
7451	N104:51	47452	R/W	Time Schedule Wednesday 2nd Mode Hour 2	
7452	N104:52	47453	R/W	Time Schedule Wednesday 2nd Mode Minute 2	
7453	N104:53	47454	R/W	Time Schedule Wednesday 3rd Mode Hour 1	
7454	N104:54	47455	R/W	Time Schedule Wednesday 3rd Mode Minute 1	
7455	N104:55	47456	R/W	Time Schedule Wednesday 4th Mode Hour 2	
7456	N104:56	47457	R/W	Time Schedule Wednesday 4th Mode Minute 2	
7457	N104:57	47458	R/W	Time Schedule Thursday 1st Mode Hour 1	
7458	N104:58	47459	R/W	Time Schedule Thursday 1st Mode Minute 1	
7459	N104:59	47460	R/W	Time Schedule Thursday 2nd Mode Hour 2	
7460	N104:60	47461	R/W	Time Schedule Thursday 2nd Mode Minute 2	
7461	N104:61	47462	R/W	Time Schedule Thursday 3rd Mode Hour 1	
7462	N104:62	47463	R/W	Time Schedule Thursday 3rd Mode Minute 1	
7463	N104:63	47464	R/W	Time Schedule Thursday 4th Mode Hour 2	
7464	N104:64	47465	R/W	Time Schedule Thursday 4th Mode Minute 2	
7465	N104:65	47466	R/W	Time Schedule Friday 1st Mode Hour 1	
7466	N104:66	47467	R/W	Time Schedule Friday 1st Mode Minute 1	
7467	N104:67	47468	R/W	Time Schedule Friday 2nd Mode Hour 2	
7468	N104:68	47469	R/W	Time Schedule Friday 2nd Mode Minute 2	
7469	N104:69	47470	R/W	Time Schedule Friday 3rd Mode Hour 1	
7470	N104:70	47471	R/W	Time Schedule Friday 3rd Mode Minute 1	
7471	N104:71	47472	R/W	Time Schedule Friday 4th Mode Hour 2	
7472	N104:72	47473	R/W	Time Schedule Friday 4th Mode Minute 2	
7473	N104:73	47474	R/W	Time Schedule Saturday 1st Mode Hour 1	
7474	N104:74	47475	R/W	Time Schedule Saturday 1st Mode Minute 1	

**SETPOINT VALUES: (Continued)**

Frick® Address	AB Address	Modbus Address	Read/Write	Description of Data	Units
7475	N104:75	47476	R/W	Time Schedule Saturday 2nd Mode Hour 2	
7476	N104:76	47477	R/W	Time Schedule Saturday 2nd Mode Minute 2	
7477	N104:77	47478	R/W	Time Schedule Saturday 3rd Mode Hour 1	
7478	N104:78	47479	R/W	Time Schedule Saturday 3rd Mode Minute 1	
7479	N104:79	47480	R/W	Time Schedule Saturday 4th Mode Hour 2	
7480	N104:80	47481	R/W	Time Schedule Saturday 4th Mode Minute 2	
7486	N104:86	47487	R/W	Skip Frequency 1 Bottom	Percent (%)
7487	N104:87	47488	R/W	Skip Frequency 1 Top	
7488	N104:88	47489	R/W	Skip Frequency 2 Bottom	
7489	N104:89	47490	R/W	Skip Frequency 2 Top	
7490	N104:90	47491	R/W	Skip Frequency 3 Bottom	
7491	N104:91	47492	R/W	Skip Frequency 3 Top	
7492	N104:92	47493	R/W	Skip Frequency 4 Bottom	
7493	N104:93	47494	R/W	Skip Frequency 4 Top	
7494	N104:94	47495	R/W	Skip Frequency 5 Bottom	
7495	N104:95	47496	R/W	Skip Frequency 5 Top	
7500	N105:00	47501	R/W	Demand/Cycling On	Pressure (Magnitude)
7501	N105:01	47502	R/W	Demand/Cycling Off	
7502	N105:02	47503	R/W	Lube Time When Starting	Seconds
7503	N105:03	47504	R/W	Post Lube When Stopping	Minutes
7510	N105:10	47511	R/W	High Suction Pressure Load Inhibit	Pressure
7511	N105:11	47512	R/W	High Suction Pressure Force Unload	
7512	N105:12	47513	R/W	High Suction Pressure Shutdown	
7513	N105:13	47514	R/W	High Suction Pressure Warning	
7514	N105:14	47515	R/W	High Suction Pressure Shutdown Delay	Seconds
7515	N105:15	47516	R/W	High Suction Pressure Warning Delay	Seconds
7520	N105:20	47521	R/W	High Discharge Temperature Shutdown	Temperature
7521	N105:21	47522	R/W	High Discharge Temperature Warning	
7522	N105:22	47523	R/W	High Discharge Temperature Shutdown Delay	Seconds
7523	N105:23	47524	R/W	High Discharge Temperature Warning Delay	
7524	N105:24	47525	R/W	High Discharge Temperature Load Inhibit	Temperature
7525	N105:25	47526	R/W	High Discharge Temperature Force Unload	
7526	N105:26	47527	R/W	High Discharge Pressure Inhibit Load Mode 1	Pressure (Positive)
7527	N105:27	47528	R/W	High Discharge Pressure Force Unload Mode 1	
7528	N105:28	47529	R/W	High Discharge Pressure Warning Mode 1	
7529	N105:29	47530	R/W	High Discharge Pressure Shutdown Mode 1	
7530	N105:30	47531	R/W	High Discharge Pressure Warning Mode 1 Delay	Seconds
7531	N105:31	47532	R/W	High Discharge Pressure Shutdown Mode 1 Delay	
7532	N105:32	47533	R/W	High Discharge Pressure Inhibit Load Mode 2	Pressure (Positive)
7533	N105:33	47534	R/W	High Discharge Pressure Force Unload Mode 2	
7534	N105:34	47535	R/W	High Discharge Pressure Warning Mode 2	
7535	N105:35	47536	R/W	High Discharge Pressure Shutdown Mode 2	
7536	N105:36	47537	R/W	High Discharge Pressure Warning Mode 2 Delay	Seconds
7537	N105:37	47538	R/W	High Discharge Pressure Shutdown Mode 2 Delay	
7538	N105:38	47539	R/W	Starting Differential Pressure	Pressure (Magnitude)
7550	N105:50	47551	R/W	Oil Heater Off When Above	Temperature

**SETPOINT VALUES: (Continued)**

Frick® Address	AB Address	Modbus Address	Read/Write	Description of Data	Units
7551	N105:51	47552	R/W	Oil Injection On When Above	Temperature
7552	N105:52	47553	R/W	Oil Injection On Delay	Seconds
7553	N105:53	47554	R/W	Missing Oil Pressure Warning Offset	Pressure (Magnitude)
7554	N105:54	47555	R/W	Missing Oil Pressure Warning Delay	Seconds
7555	N105:55	47556	R/W	Missing Oil Pressure Shutdown Offset	Pressure (Magnitude)
7556	N105:56	47557	R/W	Missing Oil Pressure Shutdown Delay A	Seconds
7557	N105:57	47558	R/W	Missing Oil Pressure Shutdown Delay B	
7558	N105:58	47559	R/W	Insufficient Oil Pressure Safety Offset	Pressure (Magnitude)
7559	N105:59	47560	R/W	Insufficient Oil Pressure Shutdown Capacity Value	Percent (%)
7560	N105:60	47561	R/W	Insufficient Oil Pressure Shutdown Delay	Seconds
7561	N105:61	47562	R/W	Insufficient Oil Pressure Load Inhibit Capacity Value	Percent (%)
7562	N105:62	47563	R/W	Insufficient Oil Pressure Force Unload Capacity Value	
7563	N105:63	47564	R/W	High Oil Temperature Shutdown	Temperature
7564	N105:64	47565	R/W	High Oil Temperature Warning	
7565	N105:65	47566	R/W	High Oil Temperature Shutdown Delay	Seconds
7566	N105:66	47567	R/W	High Oil Temperature Warning Delay	
7567	N105:67	47568	R/W	Low Oil Temperature Shutdown	Temperature
7568	N105:68	47569	R/W	Low Oil Temperature Warning	
7569	N105:69	47570	R/W	Low Oil Temperature Shutdown Delay	Seconds
7570	N105:70	47571	R/W	Low Oil Temperature Warning Delay	
7571	N105:71	47572	R/W	Low Oil Injection Pressure Shutdown	Pressure (Magnitude)
7572	N105:72	47573	R/W	Low Oil Injection Pressure Shutdown Delay	Seconds
7573	N105:73	47574	R/W	Low Oil Level Shutdown Delay	Seconds
7574	N105:74	47575	R/W	Low Oil Pressure Shutdown	Pressure (Magnitude)
7575	N105:75	47576	R/W	Low Oil Pressure Warning	
7576	N105:76	47577	R/W	Low Oil Pressure Shutdown Delay	Seconds
7577	N105:77	47578	R/W	Low Oil Pressure Warning Delay	
7578	N105:78	47579	R/W	Low Oil Pressure Shutdown 2	Pressure (Magnitude)
7579	N105:79	47580	R/W	Low Oil Pressure Shutdown Delay 2	Seconds
7580	N105:80	47581	R/W	Low Separator Temperature Shutdown	Temperature
7581	N105:81	47582	R/W	Low Separator Temperature Warning	
7582	N105:82	47583	R/W	Low Separator Temperature Shutdown Delay	Seconds
7583	N105:83	47584	R/W	Low Separator Temperature Warning Delay	
7584	N105:84	47585	R/W	Dual Pump Transition Time	
7585	N105:85	47586	R/W	Oil Log Shutdown Delay	
7586	N105:86	47587	R/W	Dual Pump Transition Time Due To Low Oil Pressure	
7587	N105:87	47588	R/W	Separator Velocity Reference	Real
7588	N105:88	47589	R/W	Separator Velocity Ratio	
7600	N106:00	47601	R/W	High Filter Shutdown	Pressure (Magnitude)
7601	N106:01	47602	R/W	High Filter Shutdown Delay	Minutes
7602	N106:02	47603	R/W	High Filter Warning	Pressure (Magnitude)
7603	N106:03	47604	R/W	High Filter Warning Delay	Minutes
7604	N106:04	47605	R/W	Condenser High Pressure Override	Pressure
7605	N106:05	47606	R/W	Condenser High Pressure Override Delay	Seconds
7606	N106:06	47607	R/W	Condenser Proportional Band	Pressure (Magnitude)
7607	N106:07	47608	R/W	Condenser Integration Time	Seconds
7608	N106:08	47609	R/W	Condenser High Limit	Percent (%)
7609	N106:09	47610	R/W	Condenser Low Limit	
7610	N106:10	47611	R/W	Condenser Control Setpoint	Pressure

**SETPOINT VALUES: (Continued)**

Frick® Address	AB Address	Modbus Address	Read/Write	Description of Data	Units
7611	N106:11	47612	R/W	Condenser High Dead Band	Pressure (Magnitude)
7612	N106:12	47613	R/W	Condenser Low Dead Band	
7613	N106:13	47614	R/W	Condenser High Step Delay	Seconds
7614	N106:14	47615	R/W	Condenser Low Step Delay	
7615	N106:15	47616	R/W	Condenser Order Step 1	Integer
7616	N106:16	47617	R/W	Condenser Order Step 2	
7617	N106:17	47618	R/W	Condenser Order Step 3	
7618	N106:18	47619	R/W	Condenser Order Step 4	
7620	N106:20	47621	R/W	Balance Piston On	Percent (%)
7621	N106:21	47622	R/W	Balance Piston Off	Percent (%)
7622	N106:22	47623	R/W	Balance Piston Ignore Period	Minutes
7623	N106:23	47624	R/W	Balance Piston Safety Delay	
7635	N106:35	47636	R/W	Liquid Slug Warning Setpoint	Temp. (Magnitude)
7636	N106:36	47637	R/W	Liquid Slug Shutdown Setpoint	
7640	N106:40	47641	R/W	Liquid Level Setpoint	None
7641	N106:41	47642	R/W	Liquid Level Deadband	
7642	N106:42	47643	R/W	Liquid Level Proportional Band	
7643	N106:43	47644	R/W	High Liquid Level Delay	
7650	N106:50	47651	R/W	Liquid Injection On When Above	Temperature
7651	N106:51	47652	R/W	Liquid Injection On Delay	Seconds
7660	N106:60	47661	R/W	Dx Circuit 1OnWhenAbove	Percent (%)
7661	N106:61	47662	R/W	Dx Circuit 1Off When Below	
7662	N106:62	47663	R/W	Dx Circuit 2 On When Above	
7663	N106:63	47664	R/W	Dx Circuit 2 Off When Below	
7664	N106:64	47665	R	Dewpoint Temperature of Discharge	Temperature
7670	N106:70	47671	R/W	Economizer On When Above	Percent (%)
7671	N106:71	47672	R/W	Economizer Off When Below	
7672	N106:72	47673	R/W	Economizer Over Ride	Pressure (Magnitude)
7673	N106:73	47674	R/W	Economizer Port Value	Real
7674	N106:74	47675	R/W	Economizer Fixed Pressure	Pressure (Positive)
7680	N106:80	47681	R/W	Pump Down Setpoint	Pressure
7681	N106:81	47682	R/W	Pump Down Time When Stopping	Minutes
7690	N106:90	47691	R/W	Capacity Pulldown Step	Percent (%)
7691	N106:91	47692	R/W	Capacity Pulldown Step Time	Seconds
7700	N107:00	47701	R/W	Auxiliary Input 1 Delay	Seconds
7701	N107:01	47702	R/W	Auxiliary Input 2 Delay	
7702	N107:02	47703	R/W	Auxiliary Input 3 Delay	
7703	N107:03	47704	R/W	Auxiliary Input 4 Delay	
7704	N107:04	47705	R/W	Auxiliary Input 5 Delay	
7705	N107:05	47706	R/W	Auxiliary Input 6 Delay	
7706	N107:06	47707	R/W	Auxiliary Input 7 Delay	
7707	N107:07	47708	R/W	Auxiliary Input 8 Delay	
7708	N107:08	47709	R/W	Auxiliary Input 9 Delay	

**SETPOINT VALUES: (Continued)**

Frick® Address	AB Address	Modbus Address	Read/Write	Description of Data	Units
7709	N107:09	47710	R/W	Auxiliary Input 10 Delay	Seconds
7710	N107:10	47711	R/W	Auxiliary Input 11 Delay	
7711	N107:11	47712	R/W	Auxiliary Input 12 Delay	
7712	N107:12	47713	R/W	Auxiliary Input 13 Delay	
7713	N107:13	47714	R/W	Auxiliary Input 14 Delay	
7714	N107:14	47715	R/W	Auxiliary Input 15 Delay	Seconds
7715	N107:15	47716	R/W	Auxiliary Input 16 Delay	
7716	N107:16	47717	R/W	Auxiliary Input 17 Delay	
7717	N107:17	47718	R/W	Auxiliary Input 18 Delay	
7718	N107:18	47719	R/W	Auxiliary Input 19 Delay	
7719	N107:19	47720	R/W	Auxiliary Input 20 Delay	
7730	N107:30	47731	R/W	Auxiliary Analog 1 High Shutdown	Pressure
7731	N107:31	47732	R/W	Auxiliary Analog 1 High Shutdown Delay	Seconds
7732	N107:32	47733	R/W	Auxiliary Analog 1 High Warning	Pressure
7733	N107:33	47734	R/W	Auxiliary Analog 1 High Warning Delay	Seconds
7734	N107:34	47735	R/W	Auxiliary Analog 1 Low Shutdown	Pressure
7735	N107:35	47736	R/W	Auxiliary Analog 1 Low Shutdown Delay	Seconds
7736	N107:36	47737	R/W	Auxiliary Analog 1 Low Warning	Pressure
7737	N107:37	47738	R/W	Auxiliary Analog 1 Low Warning Delay	Seconds
7740	N107:40	47741	R/W	Auxiliary Analog 2 High Shutdown	Pressure
7741	N107:41	47742	R/W	Auxiliary Analog 2 High Shutdown Delay	Seconds
7742	N107:42	47743	R/W	Auxiliary Analog 2 High Warning	Pressure
7743	N107:43	47744	R/W	Auxiliary Analog 2 High Warning Delay	Seconds
7744	N107:44	47745	R/W	Auxiliary Analog 2 Low Shutdown	Pressure
7745	N107:45	47746	R/W	Auxiliary Analog 2 Low Shutdown Delay	Seconds
7746	N107:46	47747	R/W	Auxiliary Analog 2 Low Warning	Pressure
7747	N107:47	47748	R/W	Auxiliary Analog 2 Low Warning Delay	Seconds
7750	N107:50	47751	R/W	Auxiliary Analog 3 High Shutdown	Pressure
7751	N107:51	47752	R/W	Auxiliary Analog 3 High Shutdown Delay	Seconds
7752	N107:52	47753	R/W	Auxiliary Analog 3 High Warning	Pressure
7753	N107:53	47754	R/W	Auxiliary Analog 3 High Warning Delay	Seconds
7754	N107:54	47755	R/W	Auxiliary Analog 3 Low Shutdown	Pressure
7755	N107:55	47756	R/W	Auxiliary Analog 3 Low Shutdown Delay	Seconds
7756	N107:56	47757	R/W	Auxiliary Analog 3 Low Warning	Pressure
7757	N107:57	47758	R/W	Auxiliary Analog 3 Low Warning Delay	Seconds
7760	N107:60	47761	R/W	Auxiliary Analog 4 High Shutdown	Pressure
7761	N107:61	47762	R/W	Auxiliary Analog 4 High Shutdown Delay	Seconds
7762	N107:62	47763	R/W	Auxiliary Analog 4 High Warning	Pressure
7763	N107:63	47764	R/W	Auxiliary Analog 4 High Warning Delay	Seconds
7764	N107:64	47765	R/W	Auxiliary Analog 4 Low Shutdown	Pressure
7765	N107:65	47766	R/W	Auxiliary Analog 4 Low Shutdown Delay	Seconds
7766	N107:66	47767	R/W	Auxiliary Analog 4 Low Warning	Pressure
7767	N107:67	47768	R/W	Auxiliary Analog 4 Low Warning Delay	Seconds
7770	N107:70	47771	R/W	Auxiliary Analog 5 High Shutdown	Pressure
7771	N107:71	47772	R/W	Auxiliary Analog 5 High Shutdown Delay	Seconds

**SETPOINT VALUES: (Continued)**

Frick® Address	AB Address	Modbus Address	Read/Write	Description of Data	Units
7772	N107:72	47773	R/W	Auxiliary Analog 5 High Warning	Pressure
7773	N107:73	47774	R/W	Auxiliary Analog 5 High Warning Delay	Seconds
7774	N107:74	47775	R/W	Auxiliary Analog 5 Low Shutdown	Pressure
7775	N107:75	47776	R/W	Auxiliary Analog 5 Low Shutdown Delay	Seconds
7776	N107:76	47777	R/W	Auxiliary Analog 5 Low Warning	Pressure
7777	N107:77	47778	R/W	Auxiliary Analog 5 Low Warning Delay	Seconds
7780	N107:80	47781	R/W	Auxiliary Analog 6 High Shutdown	Pressure
7781	N107:81	47782	R/W	Auxiliary Analog 6 High Shutdown Delay	Seconds
7782	N107:82	47783	R/W	Auxiliary Analog 6 High Warning	Pressure
7783	N107:83	47784	R/W	Auxiliary Analog 6 High Warning Delay	Seconds
7784	N107:84	47785	R/W	Auxiliary Analog 6 Low Shutdown	Pressure
7785	N107:85	47776	R/W	Auxiliary Analog 6 Low Shutdown Delay	Seconds
7786	N107:86	47787	R/W	Auxiliary Analog 6 Low Warning	Pressure
7787	N107:87	47788	R/W	Auxiliary Analog 6 Low Warning Delay	Seconds
7790	N107:90	47791	R/W	Auxiliary Analog 7 High Shutdown	Pressure
7791	N107:91	47792	R/W	Auxiliary Analog 7 High Shutdown Delay	Seconds
7792	N107:92	47793	R/W	Auxiliary Analog 7 High Warning	Pressure
7793	N107:93	47794	R/W	Auxiliary Analog 7 High Warning Delay	Seconds
7794	N107:94	47795	R/W	Auxiliary Analog 7 Low Shutdown	Pressure
7795	N107:95	47796	R/W	Auxiliary Analog 7 Low Shutdown Delay	Seconds
7796	N107:96	47797	R/W	Auxiliary Analog 7 Low Warning	Pressure
7797	N107:97	47798	R/W	Auxiliary Analog 7 Low Warning Delay	Seconds
7800	N108:00	47801	R/W	Auxiliary Analog 8 High Shutdown	Pressure
7801	N108:01	47802	R/W	Auxiliary Analog 8 High Shutdown Delay	Seconds
7802	N108:02	47803	R/W	Auxiliary Analog 8 High Warning	Pressure
7803	N108:03	47804	R/W	Auxiliary Analog 8 High Warning Delay	Seconds
7804	N108:04	47805	R/W	Auxiliary Analog 8 Low Shutdown	Pressure
7805	N108:05	47806	R/W	Auxiliary Analog 8 Low Shutdown Delay	Seconds
7806	N108:06	47807	R/W	Auxiliary Analog 8 Low Warning	Pressure
7807	N108:07	47808	R/W	Auxiliary Analog 8 Low Warning Delay	Seconds
7810	N108:10	47811	R/W	Auxiliary Analog 9 High Shutdown	Pressure
7811	N108:11	47812	R/W	Auxiliary Analog 9 High Shutdown Delay	Seconds
7812	N108:12	47813	R/W	Auxiliary Analog 9 High Warning	Pressure
7813	N108:13	47814	R/W	Auxiliary Analog 9 High Warning Delay	Seconds
7814	N108:14	47815	R/W	Auxiliary Analog 9 Low Shutdown	Pressure
7815	N108:15	47816	R/W	Auxiliary Analog 9 Low Shutdown Delay	Seconds
7816	N108:16	47817	R/W	Auxiliary Analog 9 Low Warning	Pressure
7817	N108:17	47818	R/W	Auxiliary Analog 9 Low Warning Delay	Seconds
7820	N108:20	47821	R/W	Auxiliary Analog 10 High Shutdown	Pressure
7821	N108:21	47822	R/W	Auxiliary Analog 10 High Shutdown Delay	Seconds
7822	N108:22	47823	R/W	Auxiliary Analog 10 High Warning	Pressure
7823	N108:23	47824	R/W	Auxiliary Analog 10 High Warning Delay	Seconds
7824	N108:24	47825	R/W	Auxiliary Analog 10 Low Shutdown	Pressure
7825	N108:25	47826	R/W	Auxiliary Analog 10 Low Shutdown Delay	Seconds
7826	N108:26	47827	R/W	Auxiliary Analog 10 Low Warning	Pressure
7827	N108:27	47828	R/W	Auxiliary Analog 10 Low Warning Delay	Seconds

**SETPOINT VALUES: (Continued)**

Frick® Address	AB Address	Modbus Address	Read/Write	Description of Data	Units
7830	N108:30	47831	R/W	Auxiliary Analog 11 High Shutdown	Pressure
7831	N108:31	47832	R/W	Auxiliary Analog 11 High Shutdown Delay	Seconds
7832	N108:32	47833	R/W	Auxiliary Analog 11 High Warning	Pressure
7833	N108:33	47834	R/W	Auxiliary Analog 11 High Warning Delay	Seconds
7834	N108:34	47835	R/W	Auxiliary Analog 11 Low Shutdown	Pressure
7835	N108:35	47836	R/W	Auxiliary Analog 11 Low Shutdown Delay	Seconds
7836	N108:36	47837	R/W	Auxiliary Analog 11 Low Warning	Pressure
7837	N108:37	47838	R/W	Auxiliary Analog 11 Low Warning Delay	Seconds
7840	N108:40	47841	R/W	Auxiliary Analog 12 High Shutdown	Pressure
7841	N108:41	47842	R/W	Auxiliary Analog 12 High Shutdown Delay	Seconds
7842	N108:42	47843	R/W	Auxiliary Analog 12 High Warning	Pressure
7843	N108:43	47844	R/W	Auxiliary Analog 12 High Warning Delay	Seconds
7844	N108:44	47845	R/W	Auxiliary Analog 12 Low Shutdown	Pressure
7845	N108:45	47846	R/W	Auxiliary Analog 12 Low Shutdown Delay	Seconds
7846	N108:46	47847	R/W	Auxiliary Analog 12 Low Warning	Pressure
7847	N108:47	47848	R/W	Auxiliary Analog 12 Low Warning Delay	Seconds
7850	N108:50	47851	R/W	Auxiliary Analog 13 High Shutdown	Pressure
7851	N108:51	47852	R/W	Auxiliary Analog 13 High Shutdown Delay	Seconds
7852	N108:52	47853	R/W	Auxiliary Analog 13 High Warning	Pressure
7853	N108:53	47854	R/W	Auxiliary Analog 13 High Warning Delay	Seconds
7854	N108:54	47855	R/W	Auxiliary Analog 13 Low Shutdown	Pressure
7855	N108:55	47856	R/W	Auxiliary Analog 13 Low Shutdown Delay	Seconds
7856	N108:56	47857	R/W	Auxiliary Analog 13 Low Warning	Pressure
7857	N108:57	47858	R/W	Auxiliary Analog 13 Low Warning Delay	Seconds
7860	N108:60	47861	R/W	Auxiliary Analog 14 High Shutdown	Pressure
7861	N108:61	47862	R/W	Auxiliary Analog 14 High Shutdown Delay	Seconds
7862	N108:62	47863	R/W	Auxiliary Analog 14 High Warning	Pressure
7863	N108:63	47864	R/W	Auxiliary Analog 14 High Warning Delay	Seconds
7864	N108:64	47865	R/W	Auxiliary Analog 14 Low Shutdown	Pressure
7865	N108:65	47866	R/W	Auxiliary Analog 14 Low Shutdown Delay	Seconds
7866	N108:66	47867	R/W	Auxiliary Analog 14 Low Warning	Pressure
7867	N108:67	47868	R/W	Auxiliary Analog 14 Low Warning Delay	Seconds
7870	N108:70	47871	R/W	Auxiliary Analog 15 High Shutdown	Pressure
7871	N108:71	47872	R/W	Auxiliary Analog 15 High Shutdown Delay	Seconds
7872	N108:72	47873	R/W	Auxiliary Analog 15 High Warning	Pressure
7873	N108:73	47874	R/W	Auxiliary Analog 15 High Warning Delay	Seconds
7874	N108:74	47875	R/W	Auxiliary Analog 15 Low Shutdown	Pressure
7875	N108:75	47876	R/W	Auxiliary Analog 15 Low Shutdown Delay	Seconds
7876	N108:76	47877	R/W	Auxiliary Analog 15 Low Warning	Pressure
7877	N108:77	47878	R/W	Auxiliary Analog 15 Low Warning Delay	Seconds
7880	N108:80	47881	R/W	Auxiliary Analog 16 High Shutdown	Pressure
7881	N108:81	47882	R/W	Auxiliary Analog 16 High Shutdown Delay	Seconds
7882	N108:82	47883	R/W	Auxiliary Analog 16 High Warning	Pressure
7883	N108:83	47884	R/W	Auxiliary Analog 16 High Warning Delay	Seconds
7884	N108:84	47885	R/W	Auxiliary Analog 16 Low Shutdown	Pressure

**SETPOINT VALUES: (Continued)**

Frick® Address	AB Address	Modbus Address	Read/Write	Description of Data	Units
7885	N108:85	47886	R/W	Auxiliary Analog 16 Low Shutdown Delay	Seconds
7886	N108:86	47887	R/W	Auxiliary Analog 16 Low Warning	Pressure
7887	N108:87	47888	R/W	Auxiliary Analog 16 Low Warning Delay	Seconds
7890	N108:90	47891	R/W	Auxiliary Analog 17 High Shutdown	Pressure
7891	N108:91	47892	R/W	Auxiliary Analog 17 High Shutdown Delay	Seconds
7892	N108:92	47893	R/W	Auxiliary Analog 17 High Warning	Pressure
7893	N108:93	47894	R/W	Auxiliary Analog 17 High Warning Delay	Seconds
7894	N108:94	47895	R/W	Auxiliary Analog 17 Low Shutdown	Pressure
7895	N108:95	47896	R/W	Auxiliary Analog 17 Low Shutdown Delay	Seconds
7896	N108:96	47897	R/W	Auxiliary Analog 17 Low Warning	Pressure
7897	N108:97	47898	R/W	Auxiliary Analog 17 Low Warning Delay	Seconds
7900	N109:00	47901	R/W	Auxiliary Analog 18 High Shutdown	Pressure
7901	N109:01	47902	R/W	Auxiliary Analog 18 High Shutdown Delay	Seconds
7902	N109:02	47903	R/W	Auxiliary Analog 18 High Warning	Pressure
7903	N109:03	47904	R/W	Auxiliary Analog 18 High Warning Delay	Seconds
7904	N109:04	47905	R/W	Auxiliary Analog 18 Low Shutdown	Pressure
7905	N109:05	47906	R/W	Auxiliary Analog 18 Low Shutdown Delay	Seconds
7906	N109:06	47907	R/W	Auxiliary Analog 18 Low Warning	Pressure
7907	N109:07	47908	R/W	Auxiliary Analog 18 Low Warning Delay	Seconds
7910	N109:10	47911	R/W	Auxiliary Analog 19 High Shutdown	Pressure
7911	N109:11	47912	R/W	Auxiliary Analog 19 High Shutdown Delay	Seconds
7912	N109:12	47913	R/W	Auxiliary Analog 19 High Warning	Pressure
7913	N109:13	47914	R/W	Auxiliary Analog 19 High Warning Delay	Seconds
7914	N109:14	47915	R/W	Auxiliary Analog 19 Low Shutdown	Pressure
7915	N109:15	47916	R/W	Auxiliary Analog 19 Low Shutdown Delay	Seconds
7916	N109:16	47917	R/W	Auxiliary Analog 19 Low Warning	Pressure
7917	N109:17	47918	R/W	Auxiliary Analog 19 Low Warning Delay	Seconds
7920	N109:20	47921	R/W	Auxiliary Analog 20 High Shutdown	Pressure
7921	N109:21	47922	R/W	Auxiliary Analog 20 High Shutdown Delay	Seconds
7922	N109:22	47923	R/W	Auxiliary Analog 20 High Warning	Pressure
7923	N109:23	47924	R/W	Auxiliary Analog 20 High Warning Delay	Seconds
7924	N109:24	47925	R/W	Auxiliary Analog 20 Low Shutdown	Pressure
7925	N109:25	47926	R/W	Auxiliary Analog 20 Low Shutdown Delay	Seconds
7926	N109:26	47927	R/W	Auxiliary Analog 20 Low Warning	Pressure
7927	N109:27	47928	R/W	Auxiliary Analog 20 Low Warning Delay	Seconds
7930	N109:30	47931	R/W	High Entering Process Temperature Shutdown	Temperature
7931	N109:31	47932	R/W	High Entering Process Temperature Warning	
7932	N109:32	47933	R/W	High Entering Process Temperature Shutdown Delay	Seconds
7933	N109:33	47934	R/W	High Entering Process Temperature Warning Delay	
7934	N109:34	47935	R/W	Low Entering Process Temperature Shutdown	Temperature
7935	N109:35	47936	R/W	Low Entering Process Temperature Warning	
7936	N109:36	47937	R/W	Low Entering Process Temperature Shutdown Delay	Seconds
7937	N109:37	47938	R/W	Low Entering Process Temperature Warning Delay	
8000	N110:00	48001	R/W	PID 1 Setpoint	Temperature

**SETPOINT VALUES: (Continued)**

Frick® Address	AB Address	Modbus Address	Read/Write	Description of Data	Units
8001	N110:01	48002	R/W	PID 1 Deadband	None
8002	N110:02	48003	R/W	PID 1 Proportional Band	Temp. (Magnitude)
8003	N110:03	48004	R/W	PID 1 Integral Gain	Real
8004	N110:04	48005	R/W	PID 1 Derivative Gain	
8005	N110:05	48006	R/W	PID 1 High Limit	
8006	N110:06	48007	R/W	PID 1 Low Limit	Percent (%)
8007	N110:07	48008	R/W	PID 1 When Running Off Value	
8008	N110:08	48009	R/W	PID 2 Setpoint	None
8009	N110:09	48010	R/W	PID 2 Deadband	
8010	N110:10	48011	R/W	PID 2 Proportional Band	
8011	N110:11	48012	R/W	PID 2 Integral Gain	Real
8012	N110:12	48013	R/W	PID 2 Derivative Gain	
8013	N110:13	48014	R/W	PID 2 High Limit	
8014	N110:14	48015	R/W	PID 2 Low Limit	Percent (%)
8015	N110:15	48016	R/W	PID 2 When Running Off Value	
8016	N110:16	48017	R/W	PID 3 Setpoint	None
8017	N110:17	48018	R/W	PID 3 Deadband	
8018	N110:18	48019	R/W	PID 3 Proportional Band	
8019	N110:19	48020	R/W	PID 3 Integral Gain	Real
8020	N110:20	48021	R/W	PID 3 Derivative Gain	
8021	N110:21	48022	R/W	PID 3 High Limit	
8022	N110:22	48023	R/W	PID 3 Low Limit	Percent (%)
8023	N110:23	48024	R/W	PID 3 When Running Off Value	
8024	N110:24	48025	R/W	PID 4 Setpoint	None
8025	N110:25	48026	R/W	PID 4 Deadband	
8026	N110:26	48027	R/W	PID 4 Proportional Band	
8027	N110:27	48028	R/W	PID 4 Integral Gain	Real
8028	N110:28	48029	R/W	PID 4 Derivative Gain	
8029	N110:29	48030	R/W	PID 4 High Limit	
8030	N110:30	48031	R/W	PID 4 Low Limit	Percent (%)
8031	N110:31	48032	R/W	PID 4 When Running Off Value	
8032	N110:32	48033	R/W	PID 5 Setpoint	None
8033	N110:33	48034	R/W	PID 5 Deadband	
8034	N110:34	48035	R/W	PID 5 Proportional Band	
8035	N110:35	48036	R/W	PID 5 Integral Gain	Real
8036	N110:36	48037	R/W	PID 5 Derivative Gain	
8037	N110:37	48038	R/W	PID 5 High Limit	
8038	N110:38	48039	R/W	PID 5 Low Limit	Percent (%)
8039	N110:39	48040	R/W	PID 5 When Running Off Value	
8040	N110:40	48041	R/W	PID 6 Setpoint	None
8041	N110:41	48042	R/W	PID 6 Deadband	
8042	N110:42	48043	R/W	PID 6 Proportional Band	
8043	N110:43	48044	R/W	PID 6 Integral Gain	Real
8044	N110:44	48045	R/W	PID 6 Derivative Gain	
8045	N110:45	48046	R/W	PID 6 High Limit	
8046	N110:46	48047	R/W	PID 6 Low Limit	Percent (%)
8047	N110:47	48048	R/W	PID 6 When Running Off Value	
8048	N110:48	48049	R/W	PID 7 Setpoint	None
8049	N110:49	48050	R/W	PID 7 Deadband	

**SETPOINT VALUES: (Continued)**

Frick® Address	AB Address	Modbus Address	Read/Write	Description of Data	Units
8050	N110:50	48051	R/W	PID 7 Proportional Band	None
8051	N110:51	48052	R/W	PID 7 Integral Gain	Real
8052	N110:52	48053	R/W	PID 7 Derivative Gain	
8053	N110:53	48054	R/W	PID 7 High Limit	Percent (%)
8054	N110:54	48055	R/W	PID 7 Low Limit	
8055	N110:55	48056	R/W	PID 7 When Running Off Value	
8056	N110:56	48057	R/W	PID 8 Setpoint	None
8057	N110:57	48058	R/W	PID 8 Deadband	
8058	N110:58	48059	R/W	PID 8 Proportional Band	Real
8059	N110:59	48060	R/W	PID 8 Integral Gain	
8060	N110:60	48061	R/W	PID 8 Derivative Gain	
8061	N110:61	48062	R/W	PID 8 High Limit	Percent (%)
8062	N110:62	48063	R/W	PID 8 Low Limit	
8063	N110:63	48064	R/W	PID 8 When Running Off Value	
8070	N110:70	48071	R/W	High Compressor Vibration Warning - Suction	Vibration (Fg)
8071	N110:71	48072	R/W	High Compressor Vibration Warning Delay - Suction	Seconds
8072	N110:72	48073	R/W	High Compressor Vibration Warning - Discharge	Vibration (Fg)
8073	N110:73	48074	R/W	High Compressor Vibration Warning Delay - Discharge	Seconds
8074	N110:74	48075	R/W	High Compressor Vibration Shutdown - Suction	Vibration (Fg)
8075	N110:75	48076	R/W	High Compressor Vibration Shutdown Delay - Suction	Seconds
8076	N110:76	48077	R/W	High Compressor Vibration Shutdown - Discharge	Vibration (Fg)
8077	N110:77	48078	R/W	High Compressor Vibration Shutdown Delay - Discharge	Seconds
8078	N110:78	48079	R/W	High Motor Vibration Warning - Shaft Side	Vibration (Fg)
8079	N110:79	48080	R/W	High Motor Vibration Warning Delay - Shaft Side	Seconds
8080	N110:80	48081	R/W	High Motor Vibration Warning - Opposite Shaft Side	Vibration (Fg)
8081	N110:81	48082	R/W	High Motor Vibration Warning Delay - Opposite Shaft Side	Seconds
8082	N110:82	48083	R/W	High Motor Vibration Shutdown - Shaft Side	Vibration (Fg)
8083	N110:83	48084	R/W	High Motor Vibration Shutdown Delay - Shaft Side	Seconds
8084	N110:84	48085	R/W	High Motor Vibration Shutdown - Opposite Shaft Side	Vibration (Fg)
8085	N110:85	48086	R/W	High Motor Vibration Shutdown Delay - Opposite Shaft Side	Seconds
8086	N110:86	48087	R/W	High Motor Temp. Warning - Shaft Side	Temperature
8087	N110:87	48088	R/W	High Motor Temp. Warning Delay - Shaft Side	Seconds
8088	N110:88	48089	R/W	High Motor Temp. Warning - Opposite Shaft Side	Temperature
8089	N110:89	48090	R/W	High Motor Temp. Warning Delay - Opposite Shaft Side	Seconds
8090	N110:90	48091	R/W	High Motor Temp. Shutdown - Shaft Side	Temperature
8091	N110:91	48092	R/W	High Motor Temp. Shutdown Delay - Shaft Side	Seconds
8092	N110:92	48093	R/W	High Motor Temp. Shutdown - Opposite Shaft Side	Temperature
8093	N110:93	48094	R/W	High Motor Temp. Shutdown Delay - Opposite Shaft Side	Seconds
8140	N111:40	48141	R/W	High Motor Stator #1 Temperature Warning	Temperature
8141	N111:41	48142	R/W	High Motor Stator #1 Temperature Warning Delay	Seconds
8142	N111:42	48143	R/W	High Motor Stator #1 Temperature Shutdown	Temperature
8143	N111:43	48144	R/W	High Motor Stator #1 Temperature Shutdown Delay	Seconds
8144	N111:44	48145	R/W	High Motor Stator #2 Temperature Warning	Temperature
8145	N111:45	48146	R/W	High Motor Stator #2 Temperature Warning Delay	Seconds
8146	N111:46	48147	R/W	High Motor Stator #2 Temperature Shutdown	Temperature
8147	N111:47	48148	R/W	High Motor Stator #2 Temperature Shutdown Delay	Seconds
8148	N111:48	48149	R/W	High Motor Stator #3 Temperature Warning	Temperature
8149	N111:49	48150	R/W	High Motor Stator #3 Temperature Warning Delay	Seconds

**SETPOINT VALUES: (Continued)**

Frick® Address	AB Address	Modbus Address	Read/Write	Description of Data	Units
8150	N111:50	48151	R/W	High Motor Stator #3 Temperature Shutdown	Temperature
8151	N111:51	48152	R/W	High Motor Stator #3 Temperature Shutdown Delay	Seconds
8201	N112:01	48202	R/W	Oil Analysis Service Interval	Hours
8202	N112:02	48203	R/W	Change Filters Service Interval	
8203	N112:03	48204	R/W	Clean Oil Strainers Service Interval	
8204	N112:04	48205	R/W	Clean Liquid Strainers Service Interval	
8205	N112:05	48206	R/W	Clean Coalescers Service Interval	
8206	N112:06	48207	R/W	Clean Suction Screen Service Interval	
8207	N112:07	48208	R/W	Vibration Analysis Service Interval	
8208	N112:08	48209	R/W	Check Coupling Service Interval	
8209	N112:09	48210	R/W	Grease Motor Service Interval	
8210	N112:10	48211	R/W	User Defined #1 Service Interval	Hours
8211	N112:11	48212	R/W	User Defined #2 Service Interval	
8212	N112:12	48213	R/W	User Defined #3 Service Interval	
8213	N112:13	48214	R/W	User Defined #4 Service Interval	
8214	N112:14	48215	R/W	User Defined #5 Service Interval	
8215	N112:15	48216	R/W	User Defined #6 Service Interval	
8216	N112:16	48217	R/W	User Defined #7 Service Interval	
8217	N112:17	48218	R/W	User Defined #8 Service Interval	
8218	N112:18	48219	R/W	Oil Analysis - Next Service	
8219	N112:19	48220	R/W	Change Filters - Next Service	
8220	N112:20	48221	R/W	Clean Oil Stainers - Next Service	
8221	N112:21	48222	R/W	Clean Liquid Strainers - Next Service	
8222	N112:22	48223	R/W	Clean Coalescers - Next Service	
8223	N112:23	48224	R/W	Clean Suction Screen - Next Service	
8224	N112:24	48225	R/W	Vibration Analysis - Next Service	
8225	N112:25	48226	R/W	Check Coupling - Next Service	
8226	N112:26	48227	R/W	Grease Motor - Next Service	
8227	N112:27	48228	R/W	User Defined #1 - Next Service	
8228	N112:28	48229	R/W	User Defined #2 - Next Service	
8229	N112:29	48230	R/W	User Defined #3 - Next Service	
8230	N112:30	48231	R/W	User Defined #4 - Next Service	
8231	N112:31	48232	R/W	User Defined #5 - Next Service	
8232	N112:32	48233	R/W	User Defined #6 - Next Service	
8233	N112:33	48234	R/W	User Defined #7 - Next Service	
8234	N112:34	48235	R/W	User Defined #8 - Next Service	
8300	N113:00	48301	R/W	Sequencing - System 1 Compressor 1 ID	None
8301	N113:01	48302	R/W	Sequencing - System 1 Compressor 2 ID	
8302	N113:02	48303	R/W	Sequencing - System 1 Compressor 3 ID	
8303	N113:03	48304	R/W	Sequencing - System 1 Compressor 4 ID	
8304	N113:04	48305	R/W	Sequencing - System 1 Compressor 5 ID	
8305	N113:05	48306	R/W	Sequencing - System 1 Compressor 6 ID	
8306	N113:06	48307	R/W	Sequencing - System 1 Compressor 7 ID	
8307	N113:07	48308	R/W	Sequencing - System 1 Compressor 8 ID	
8308	N113:08	48309	R/W	Sequencing - System 1 Compressor 1 Start #	
8309	N113:09	48310	R/W	Sequencing - System 1 Compressor 2 Start #	

**SETPOINT VALUES: (Continued)**

Frick® Address	AB Address	Modbus Address	Read/Write	Description of Data	Units
8310	N113:10	48311	R/W	Sequencing - System 1 Compressor 3 Start #	None
8311	N113:11	48312	R/W	Sequencing - System 1 Compressor 4 Start #	
8312	N113:12	48313	R/W	Sequencing - System 1 Compressor 5 Start #	
8313	N113:13	48314	R/W	Sequencing - System 1 Compressor 6 Start #	
8314	N113:14	48315	R/W	Sequencing - System 1 Compressor 7 Start #	
8315	N113:15	48316	R/W	Sequencing - System 1 Compressor 8 Start #	
8316	N113:16	48317	R/W	Sequencing - System 1 Capacity Control Setpoint	Temperature
8317	N113:17	48318	R/W	Sequencing - System 1 Control Point	
8318	N113:18	48319	R/W	Sequencing - System 1 Minimum Run Time	Minutes
8319	N113:19	48320	R/W	Sequencing - System 1 Compressor 1 Capacity	Real
8320	N113:20	48321	R/W	Sequencing - System 1 Compressor 2 Capacity	
8321	N113:21	48322	R/W	Sequencing - System 1 Compressor 3 Capacity	
8322	N113:22	48323	R/W	Sequencing - System 1 Compressor 4 Capacity	
8323	N113:23	48324	R/W	Sequencing - System 1 Compressor 5 Capacity	Real
8324	N113:24	48325	R/W	Sequencing - System 1 Compressor 6 Capacity	
8325	N113:25	48326	R/W	Sequencing - System 1 Compressor 7 Capacity	
8326	N113:26	48327	R/W	Sequencing - System 1 Compressor 8 Capacity	
8327	N113:27	48328	R/W	Sequencing - System 1 Compressor 1 Run Time	Integer
8328	N113:28	48329	R/W	Sequencing - System 1 Compressor 2 Run Time	
8329	N113:29	48330	R/W	Sequencing - System 1 Compressor 3 Run Time	
8330	N113:30	48331	R/W	Sequencing - System 1 Compressor 4 Run Time	
8331	N113:31	48332	R/W	Sequencing - System 1 Compressor 5 Run Time	
8332	N113:32	48333	R/W	Sequencing - System 1 Compressor 6 Run Time	
8333	N113:33	48334	R/W	Sequencing - System 1 Compressor 7 Run Time	Integer
8334	N113:34	48335	R/W	Sequencing - System 1 Compressor 8 Run Time	
8335	N113:35	48336	R/W	Sequencing - System 1 Compressor 1 Minimum Capacity	
8336	N113:36	48337	R/W	Sequencing - System 1 Compressor 2 Minimum Capacity	
8337	N113:37	48338	R/W	Sequencing - System 1 Compressor 3 Minimum Capacity	
8338	N113:38	48339	R/W	Sequencing - System 1 Compressor 4 Minimum Capacity	
8339	N113:39	48340	R/W	Sequencing - System 1 Compressor 5 Minimum Capacity	Percent (%)
8340	N113:40	48341	R/W	Sequencing - System 1 Compressor 6 Minimum Capacity	
8341	N113:41	48342	R/W	Sequencing - System 1 Compressor 7 Minimum Capacity	
8342	N113:42	48343	R/W	Sequencing - System 1 Compressor 8 Minimum Capacity	
8343	N113:43	48344	R/W	Sequencing - System 1 Compressor 1 Slave Command	
8344	N113:44	48345	R/W	Sequencing - System 1 Compressor 2 Slave Command	
8345	N113:45	48346	R/W	Sequencing - System 1 Compressor 3 Slave Command	None
8346	N113:46	48347	R/W	Sequencing - System 1 Compressor 4 Slave Command	
8347	N113:47	48348	R/W	Sequencing - System 1 Compressor 5 Slave Command	
8348	N113:48	48349	R/W	Sequencing - System 1 Compressor 6 Slave Command	
8349	N113:49	48350	R/W	Sequencing - System 1 Compressor 7 Slave Command	
8350	N113:50	48351	R/W	Sequencing - System 1 Compressor 8 Slave Command	
8351	N113:51	48352	R/W	Sequencing - System 1 Compressor 1 Start Inhibits	
8352	N113:52	48353	R/W	Sequencing - System 1 Compressor 2 Start Inhibits	
8353	N113:53	48354	R/W	Sequencing - System 1 Compressor 3 Start Inhibits	
8354	N113:54	48355	R/W	Sequencing - System 1 Compressor 4 Start Inhibits	
8355	N113:55	48356	R/W	Sequencing - System 1 Compressor 5 Start Inhibits	
8356	N113:56	48357	R/W	Sequencing - System 1 Compressor 6 Start Inhibits	
8357	N113:57	48358	R/W	Sequencing - System 1 Compressor 7 Start Inhibits	
8358	N113:58	48359	R/W	Sequencing - System 1 Compressor 8 Start Inhibits	

**SETPOINT VALUES: (Continued)**

Frick® Address	AB Address	Modbus Address	Read/Write	Description of Data	Units
8400	N114:00	48401	R/W	Sequencing - System 2 Compressor 1 ID	None
8401	N114:01	48402	R/W	Sequencing - System 2 Compressor 2 ID	
8402	N114:02	48403	R/W	Sequencing - System 2 Compressor 3 ID	
8403	N114:03	48404	R/W	Sequencing - System 2 Compressor 4 ID	
8404	N114:04	48405	R/W	Sequencing - System 2 Compressor 5 ID	
8405	N114:05	48406	R/W	Sequencing - System 2 Compressor 6 ID	
8406	N114:06	48407	R/W	Sequencing - System 2 Compressor 7 ID	
8407	N114:07	48408	R/W	Sequencing - System 2 Compressor 8 ID	
8408	N114:08	48409	R/W	Sequencing - System 2 Compressor 1 Start #	
8409	N114:09	48410	R/W	Sequencing - System 2 Compressor 2 Start #	
8410	N114:10	48411	R/W	Sequencing - System 2 Compressor 3 Start #	
8411	N114:11	48412	R/W	Sequencing - System 2 Compressor 4 Start #	
8412	N114:12	48413	R/W	Sequencing - System 2 Compressor 5 Start #	None
8413	N114:13	48414	R/W	Sequencing - System 2 Compressor 6 Start #	
8414	N114:14	48415	R/W	Sequencing - System 2 Compressor 7 Start #	
8415	N114:15	48416	R/W	Sequencing - System 2 Compressor 8 Start #	Temperature
8416	N114:16	48417	R/W	Sequencing - System 2 Capacity Control Setpoint	
8417	N114:17	48418	R/W	Sequencing - System 2 Control Point	Minutes
8418	N114:18	48419	R/W	Sequencing - System 2 Minimum Run Time	
8419	N114:19	48420	R/W	Sequencing - System 2 Compressor 1 Capacity	Real
8420	N114:20	48421	R/W	Sequencing - System 2 Compressor 2 Capacity	
8421	N114:21	48422	R/W	Sequencing - System 2 Compressor 3 Capacity	
8422	N114:22	48423	R/W	Sequencing - System 2 Compressor 4 Capacity	
8423	N114:23	48424	R/W	Sequencing - System 2 Compressor 5 Capacity	
8424	N114:24	48425	R/W	Sequencing - System 2 Compressor 6 Capacity	
8425	N114:25	48426	R/W	Sequencing - System 2 Compressor 7 Capacity	
8426	N114:26	48427	R/W	Sequencing - System 2 Compressor 8 Capacity	
8427	N114:27	48428	R/W	Sequencing - System 2 Compressor 1 Run Time	Integer
8428	N114:28	48429	R/W	Sequencing - System 2 Compressor 2 Run Time	
8429	N114:29	48430	R/W	Sequencing - System 2 Compressor 3 Run Time	
8430	N114:30	48431	R/W	Sequencing - System 2 Compressor 4 Run Time	
8431	N114:31	48432	R/W	Sequencing - System 2 Compressor 5 Run Time	
8432	N114:32	48433	R/W	Sequencing - System 2 Compressor 6 Run Time	
8433	N114:33	48434	R/W	Sequencing - System 2 Compressor 7 Run Time	
8434	N114:34	48435	R/W	Sequencing - System 2 Compressor 8 Run Time	
8435	N114:35	48436	R/W	Sequencing - System 2 Compressor 1 Minimum Capacity	Percent (%)
8436	N114:36	48437	R/W	Sequencing - System 2 Compressor 2 Minimum Capacity	
8437	N114:37	48438	R/W	Sequencing - System 2 Compressor 3 Minimum Capacity	
8438	N114:38	48439	R/W	Sequencing - System 2 Compressor 4 Minimum Capacity	
8439	N114:39	48440	R/W	Sequencing - System 2 Compressor 5 Minimum Capacity	
8440	N114:40	48441	R/W	Sequencing - System 2 Compressor 6 Minimum Capacity	
8441	N114:41	48442	R/W	Sequencing - System 2 Compressor 7 Minimum Capacity	
8442	N114:42	48443	R/W	Sequencing - System 2 Compressor 8 Minimum Capacity	
8443	N114:43	48444	R/W	Sequencing - System 2 Compressor 1 Slave Command	None
8444	N114:44	48445	R/W	Sequencing - System 2 Compressor 2 Slave Command	
8445	N114:45	48446	R/W	Sequencing - System 2 Compressor 3 Slave Command	
8446	N114:46	48447	R/W	Sequencing - System 2 Compressor 4 Slave Command	
8447	N114:47	48448	R/W	Sequencing - System 2 Compressor 5 Slave Command	
8448	N114:48	48449	R/W	Sequencing - System 2 Compressor 6 Slave Command	
8449	N114:49	48450	R/W	Sequencing - System 2 Compressor 7 Slave Command	

**SETPOINT VALUES: (Continued)**

Frick® Address	AB Address	Modbus Address	Read/Write	Description of Data	Units
8450	N114:50	48451	R/W	Sequencing - System 2 Compressor 8 Slave Command	
8451	N114:51	48452	R/W	Sequencing - System 2 Compressor 1 Start Inhibits	
8452	N114:52	48453	R/W	Sequencing - System 2 Compressor 2 Start Inhibits	
8453	N114:53	48454	R/W	Sequencing - System 2 Compressor 3 Start Inhibits	
8454	N114:54	48455	R/W	Sequencing - System 2 Compressor 4 Start Inhibits	
8455	N114:55	48456	R/W	Sequencing - System 2 Compressor 5 Start Inhibits	
8456	N114:56	48457	R/W	Sequencing - System 2 Compressor 6 Start Inhibits	
8457	N114:57	48458	R/W	Sequencing - System 2 Compressor 7 Start Inhibits	
8458	N114:58	48459	R/W	Sequencing - System 2 Compressor 8 Start Inhibits	None
8500	N115:00	48501	R/W	Sequencing - System 3 Compressor 1 ID	None
8501	N115:01	48502	R/W	Sequencing - System 3 Compressor 2 ID	
8502	N115:02	48503	R/W	Sequencing - System 3 Compressor 3 ID	
8503	N115:03	48504	R/W	Sequencing - System 3 Compressor 4 ID	
8504	N115:04	48505	R/W	Sequencing - System 3 Compressor 5 ID	
8505	N115:05	48506	R/W	Sequencing - System 3 Compressor 6 ID	
8506	N115:06	48507	R/W	Sequencing - System 3 Compressor 7 ID	
8507	N115:07	48508	R/W	Sequencing - System 3 Compressor 8 ID	
8508	N115:08	48509	R/W	Sequencing - System 3 Compressor 1 Start #	
8509	N115:09	48510	R/W	Sequencing - System 3 Compressor 2 Start #	
8510	N115:10	48511	R/W	Sequencing - System 3 Compressor 3 Start #	
8511	N115:11	48512	R/W	Sequencing - System 3 Compressor 4 Start #	
8512	N115:12	48513	R/W	Sequencing - System 3 Compressor 5 Start #	
8513	N115:13	48514	R/W	Sequencing - System 3 Compressor 6 Start #	
8514	N115:14	48515	R/W	Sequencing - System 3 Compressor 7 Start #	
8515	N115:15	48516	R/W	Sequencing - System 3 Compressor 8 Start #	
8516	N115:16	48517	R/W	Sequencing - System 3 Capacity Control Setpoint	Temperature
8517	N115:17	48518	R/W	Sequencing - System 3 Control Point	Minutes
8518	N115:18	48519	R/W	Sequencing - System 3 Minimum Run Time	Real
8519	N115:19	48520	R/W	Sequencing - System 3 Compressor 1 Capacity	
8520	N115:20	48521	R/W	Sequencing - System 3 Compressor 2 Capacity	
8521	N115:21	48522	R/W	Sequencing - System 3 Compressor 3 Capacity	
8522	N115:22	48523	R/W	Sequencing - System 3 Compressor 4 Capacity	
8523	N115:23	48524	R/W	Sequencing - System 3 Compressor 5 Capacity	
8524	N115:24	48525	R/W	Sequencing - System 3 Compressor 6 Capacity	
8525	N115:25	48526	R/W	Sequencing - System 3 Compressor 7 Capacity	
8526	N115:26	48527	R/W	Sequencing - System 3 Compressor 8 Capacity	
8527	N115:27	48528	R/W	Sequencing - System 3 Compressor 1 Run Time	
8528	N115:28	48529	R/W	Sequencing - System 3 Compressor 2 Run Time	Integer
8529	N115:29	48530	R/W	Sequencing - System 3 Compressor 3 Run Time	
8530	N115:30	48531	R/W	Sequencing - System 3 Compressor 4 Run Time	
8531	N115:31	48532	R/W	Sequencing - System 3 Compressor 5 Run Time	
8532	N115:32	48533	R/W	Sequencing - System 3 Compressor 6 Run Time	
8533	N115:33	48534	R/W	Sequencing - System 3 Compressor 7 Run Time	
8534	N115:34	48535	R/W	Sequencing - System 3 Compressor 8 Run Time	
8535	N115:35	48536	R/W	Sequencing - System 3 Compressor 1 Minimum Capacity	
8536	N115:36	48537	R/W	Sequencing - System 3 Compressor 2 Minimum Capacity	
8537	N115:37	48538	R/W	Sequencing - System 3 Compressor 3 Minimum Capacity	
8538	N115:38	48539	R/W	Sequencing - System 3 Compressor 4 Minimum Capacity	
8539	N115:39	48540	R/W	Sequencing - System 3 Compressor 5 Minimum Capacity	

**SETPOINT VALUES: (Continued)**

Frick® Address	AB Address	Modbus Address	Read/Write	Description of Data	Units
8540	N115:40	48541	R/W	Sequencing - System 3 Compressor 6 Minimum Capacity	Percent (%)
8541	N115:41	48542	R/W	Sequencing - System 3 Compressor 7 Minimum Capacity	
8542	N115:42	48543	R/W	Sequencing - System 3 Compressor 8 Minimum Capacity	
8543	N115:43	48544	R/W	Sequencing - System 3 Compressor 1 Slave Command	None
8544	N115:44	48545	R/W	Sequencing - System 3 Compressor 2 Slave Command	
8545	N115:45	48546	R/W	Sequencing - System 3 Compressor 3 Slave Command	
8546	N115:46	48547	R/W	Sequencing - System 3 Compressor 4 Slave Command	
8547	N115:47	48548	R/W	Sequencing - System 3 Compressor 5 Slave Command	
8548	N115:48	48549	R/W	Sequencing - System 3 Compressor 6 Slave Command	
8549	N115:49	48550	R/W	Sequencing - System 3 Compressor 7 Slave Command	
8550	N115:50	48551	R/W	Sequencing - System 3 Compressor 8 Slave Command	
8551	N115:51	48552	R/W	Sequencing - System 3 Compressor 1 Start Inhibits	
8552	N115:52	48553	R/W	Sequencing - System 3 Compressor 2 Start Inhibits	
8553	N115:53	48554	R/W	Sequencing - System 3 Compressor 3 Start Inhibits	
8554	N115:54	48555	R/W	Sequencing - System 3 Compressor 4 Start Inhibits	
8555	N115:55	48556	R/W	Sequencing - System 3 Compressor 5 Start Inhibits	
8556	N115:56	48557	R/W	Sequencing - System 3 Compressor 6 Start Inhibits	
8557	N115:57	48558	R/W	Sequencing - System 3 Compressor 7 Start Inhibits	
8558	N115:58	48559	R/W	Sequencing - System 3 Compressor 8 Start Inhibits	

**COMMANDS:**

Frick® Address	AB Address	Modbus Address	Read/Write	Description of Data	Value Codes
8910	N119:10	48911	W	Remote – Start	1 = Start
8911	N119:11	48912	W	Remote – Stop	1 = Stop
8912	N119:12	48913	W	Remote – Load Slide Valve	0 = Turn off 1 – 15 = Load x seconds
8913	N119:13	48914	W	Remote – Unload Slide Valve	0 = Turn off 1 – 15 = Unload x seconds
8914	N119:14	48915	W	Remote – RDB Capacity	25, 50, 75, 100 (represents capacity %)
8915	N119:15	48916	W	Remote – Compressor Mode	0 = Manual 1 = Auto 2 = Remote -- Communications 3 = Remote -- I/O 5 = Remote -- Sequencing 6 = Manual -- Browser
8916	N119:16	48917	W	Remote – Capacity Mode	1 = Auto 2 = Remote -- Communications 3 = Remote -- I/O 4 = Remote -- 4-20ma 5 = Remote – Sequencing 6 = Manual -- Browser
8917	N119:17	48918	W	Remote – Clear Alarms	1 = Clear Alarms
8918	N119:18	48919	W	Remote – Clear Recycle Delay	1 = Clear Recycle Delay
8919	N119:19	48920	W	Remote – Sequencing Mode	0 = Disable 1 = Enable
8920	N119:20	48921	W	Remote – Communication Units	0 = C ° / PSIA 1 = Panel Units
8921	N119:21	48922	W	Remote – Regulation Mode	0 = Regulation Mode 1 1 = Regulation Mode 2 2 = Regulation Mode 3 3 = Regulation Mode 4
8922	N119:22	48923	W	Remote – Set Slide Valve Position	0 – 100%
8923	N119:23	48924	W	Remote – Set Drive Speed	0 – 100%
8924	N119:24	48925	W	Remote – Set Total Capacity	0 – 200

**GENERAL NOTES:**

Command Values need tenths field added. For example, to start the compressor, the table above states that 1 = Start. However, being that one decimal place is assumed, a value of 10 actually needs to be sent.

**SPECIFIC NOTES:**

**Note 1:** The compressor must be in remote communications to accept the start and stop commands that are sent through serial communications, and the Capacity Mode must be in remote communications to accept load and unload commands that are sent.

**Note 2:** To read the proper Temperature/Pressure units, use Frick® address 4566. To change (write to) the Temperature/Pressure units, use Frick® address 8920.

**Note 3:** Mode must already be enabled.

**Note 4:** The value passed with this command is the position (percentage) to which the control will attempt to set the Slide Valve. The control will automatically load and/or unload the Slide Valve until it is within a deadband (+/- 0.5%) of the target.

Conditions:

- the compressor must be running

- the Capacity Mode must be Remote Comms
- if the compressor is Variable Speed, the Slide Valve will not go below the Variable Speed Minimum Slide Valve setpoint

This command is reset by a Remote Load or Remote Unload command

**Note 5:** The value passed with this command is the speed (percentage) to which the control will attempt to set the Drive.

Conditions:

- the compressor must be Variable Speed
- the compressor must be running
- the Capacity Mode must be Remote Comms
- the Drive will not go below the Drive Speed Minimum setpoint

This command is reset by a Remote Load or Remote Unload command

**Note 6:** This command is actually a combination the previous two (Remote – Set Slide Valve Position and Remote – Set Drive Speed), and is for the convenience of the PLC programmer. A value of X from 0 to 100 will set the Slide Valve Position to X% and the Drive Speed to 0% (or the allowable minimum). A value of X from 100 to 200 will set the Slide Valve to 100% and the Drive Speed to (X – 100)%.

**DBS SETPOINT VALUES:**

Frick® Address	AB Address	Modbus Address	Read/Write	Description of Data	Units
8950	N119:50	48951	R	Average Current	Amps
8951	N119:51	48952	R	Elapsed Run Time Hours	Hours
8952	N119:52	48953	R	Elapsed Run Time Minutes	Minutes
8953	N119:53	48954	R	Current Phase A	Amps
8954	N119:54	48955	R	Current Phase B	
8955	N119:55	48956	R	Current Phase C	
8956	N119:56	48957	R	Heatsink Temperature	Temperature
8957	N119:57	48958	R	RTD Temperature	
8958	N119:58	48959	R	Thermal Capacity Used	Percent (%)
8959	N119:59	48960	R	Time until Start	Minutes
8960	N119:60	48961	R	Full Load Amps	Amps
8961	N119:61	48962	R	Locked Rotor Current	Percent (%)
8962	N119:62	48963	R	Stall Time	Seconds
8963	N119:63	48964	R	Jam Current Level	Percent (%)
8964	N119:64	48965	R	Jam Run Delay	Seconds
8965	N119:65	48966	R	DBS Service Factor	Percent (%)
8966	N119:66	48967	R	Current Unbalance Alarm Level	
8967	N119:67	48968	R	Current Unbalance Alarm Run Delay	Seconds
8968	N119:68	48969	R	RTD Temperature Alarm Level	Temperature
8969	N119:69	48970	R	RTD Temperature Trip Level	
8970	N119:70	48971	R	Bypass Time	Seconds
8971	N119:71	48972	R	Constant Current Level	Percent (%)
8972	N119:72	48973	R	Ramp Time	Seconds
8973	N119:73	48974	R	DBS Version	Real
8974	N119:74	48975	R	Last Trip Current	Amps
8975	N119:75	48976	R	Last Trip Heatsink Temp	Temperature
8976	N119:76	48977	R	Last Trip RTD Temp	
8977	N119:77	48978	R	Last Trip Thermal Capacity	Percent (%)
8978	N119:78	48979	R	Last Trip FLA	Amps
8979	N119:79	48980	R	Last Trip Current Step	Percent (%)
8980	N119:80	48981	R	Last Trip Ramp Time	Seconds
8981	N119:81	48982	R	Last Trip Bypass Time	
8982	N119:82	48983	R	Last Run Time Hours	Hours
8983	N119:83	48984	R	Last Run Time Minutes	Minutes
8984	N119:84	48985	R	Total Accumulated Run Time Hours	Hours
8985	N119:85	48986	R	Total Accumulated Run Time Minutes	Minutes
8986	N119:86	48987	R	Total Number of Starts	None
8987	N119:87	48988	R	Total Short Circuit Trips	
8988	N119:88	48989	R	Total Jam Trips	
8989	N119:89	48990	R	Total Phase Loss Trips	
8990	N119:90	48991	R	Total Phase Reversal Trips	
8991	N119:91	48992	R	Total Current Unbalance Trips	
8992	N119:92	48993	R	Total Heatsink Overtemp Trips	
8993	N119:93	48994	R	Total RTD Overtemp Trips	
8994	N119:94	48995	R	Total Thermal Overload Trips	None
8995	N119:95	48996	R	Maximum RTD Temperature	Temperature
8997	N119:97	48998	R	Locked Rotor Current Setpoint	Percent (%)
8998	N119:98	48999	R	Stall Time Setpoint	Seconds
8999	N119:99	49000	R	Jam Current Level Setpoint	Percent (%)

**DBS SETPOINT VALUES (Continued):**

Frick® Address	AB Address	Modbus Address	Read/Write	Description of Data	Units
9000	N120:00	49001	R	Jam Run Delay Setpoint	Seconds
9001	N120:01	49002	R	DBS Service Factor Setpoint	Percent (%)
9002	N120:02	49003	R	Current Unbalance Alarm Level Setpoint	
9003	N120:03	49004	R	Current Unbalance Alarm Run Delay Setpoint	Seconds
9004	N120:04	49005	R	RTD Temperature Alarm Level Setpoint	Temperature
9005	N120:05	49006	R	RTD Temperature Trip Level Setpoint	
9007	N120:07	49008	R	DBS Command Flags	None

**GENERAL SETPOINT VALUES:**

Frick® Address	AB Address	Modbus Address	Read/Write	Description of Data	Units
9100	N121:00	49101	R/W	Real Time Trending Recording Interval	Seconds
9101	N121:01	49102	R/W	History Trending Recording Interval	Minutes

**VSD (VYPER) SETPOINT VALUES:**

Frick® Address	AB Address	Modbus Address	Read/Write	Description of Data	Units
9200	N122:00	49201	R/W	Vyper Drive Standby Time	Minutes
9210	N122:10	49211	R	Vyper Drive Auto Speed Command	RPM <small>(NOTE: RPM values are NOT multiplied by 10 in Allen-Bradley and MODBUS protocols)</small>
9211	N122:11	49212	R	Vyper Drive Run Command	
9215	N122:15	49216	R	Vyper Drive Current Fault	None
9216	N122:16	49217	R	Vyper Drive Current Warning	
9218	N122:18	49219	R	Vyper Drive Speed Command	RPM <small>(NOTE: RPM values are NOT multiplied by 10 in Allen-Bradley and MODBUS protocols)</small>
9219	N122:19	49220	R	Vyper Drive Percent of Full Load Amps	
9220	N122:20	49221	R	Vyper Drive Actual Speed	RPM <small>(NOTE: RPM values are NOT multiplied by 10 in Allen-Bradley and MODBUS protocols)</small>
9223	N122:23	49224	R	Vyper Drive Operating Mode	
9224	N122:24	49225	R	Vyper Drive Water Pump	None
9225	N122:25	49226	R	Vyper Drive Precharge Relay	
9226	N122:26	49227	R	Vyper Drive Trigger SCRs	
9228	N122:28	49229	R	Vyper Drive Output Frequency	
9229	N122:29	49230	R	Vyper Drive Output Voltage	Integer
9230	N122:30	49231	R	Vyper Drive DC Bus Voltage	
9231	N122:31	49232	R	Vyper Drive Job FLA	Amps
9232	N122:32	49233	R	Vyper Drive DC Inverter Link Current	
9233	N122:33	49234	R	Vyper Drive Phase A Current	
9234	N122:34	49235	R	Vyper Drive Phase B Current	
9235	N122:35	49236	R	Vyper Drive Phase C Current	

VSD (VYPER) SETPOINT VALUES: (Continued)

Frick® Address	AB Address	Modbus Address	Read/Write	Description of Data	Units
9236	N122:36	49237	R	Vyper Drive Ambient Temperature	Temperature
9237	N122:37	49238	R	Vyper Drive Baseplate Temperature	
9238	N122:38	49239	R	Vyper Drive Converter Heatsink Temperature	
9239	N122:39	49240	R	Vyper Drive Motor Temperature	
9240	N122:40	49241	R	Vyper Drive Input Power	kW
9242	N122:42	49243	R	Vyper Drive Total Kilowatts per hour	Integer
9243	N122:43	49244	R	Vyper Drive Model	
9244	N122:44	49245	R	Harmonic Filter Present	None
9245	N122:45	49246	R	Harmonic Filter Operating Mode	
9246	N122:46	49247	R	Harmonic Filter Supply Contactor Energized	
9247	N122:47	49248	R	Harmonic Filter Precharge Contactor Energized	
9248	N122:48	4249	R	Harmonic Filter Phase Rotation Direction	
9249	N122:49	49250	R	Harmonic Filter DC Bus Voltage	Integer
9250	N122:50	49251	R	Harmonic Filter L1-N Voltage	
9251	N122:51	49252	R	Harmonic Filter L2-N Voltage	
9252	N122:52	49253	R	Harmonic Filter L3-N Voltage	
9253	N122:53	49254	R	Harmonic Filter L1-L2 Voltage	
9254	N122:54	49255	R	Harmonic Filter L2-L3 Voltage	
9255	N122:55	49256	R	Harmonic Filter L3-L1 Voltage	Percent (%)
9256	N122:56	49257	R	Harmonic Filter L1 Total Harmonic Distortion	
9257	N122:57	49258	R	Harmonic Filter L2 Total Harmonic Distortion	
9258	N122:58	49259	R	Harmonic Filter L3 Total Harmonic Distortion	Amps
9259	N122:59	49260	R	Harmonic Filter L1 Filter Current	
9260	N122:60	49261	R	Harmonic Filter L2 Filter Current	
9261	N122:61	49262	R	Harmonic Filter L3 Filter Current	
9262	N122:62	49263	R	Harmonic Filter L1 Supply Current	
9263	N122:63	49264	R	Harmonic Filter L2 Supply Current	
9264	N122:64	49265	R	Harmonic Filter L3 Supply Current	Percent (%)
9265	N122:65	49266	R	Harmonic Filter L1 Total Demand Distortion	
9266	N122:66	49267	R	Harmonic Filter L2 Total Demand Distortion	
9267	N122:67	49268	R	Harmonic Filter L3 Total Demand Distortion	Integer
9268	N122:68	49269	R	Harmonic Filter Total Supply KVA	
9269	N122:69	49270	R	Harmonic Filter Total Power Factor	Real
9270	N122:70	49271	R	Harmonic Filter Baseplate Temperature	Temperature
9271	N122:71	49272	R	Vyper Drive Auto/Manual Switch Status	None
9272	N122:72	49273	R	Vyper Drive Manual Mode Speed Switch Status	RPM
				(NOTE: RPM values are NOT multiplied by 10 in Allen-Bradley and MODBUS protocols)	
9273	N122:73	49274	R	Vyper Drive Line Frequency Jumper Status	None
9274	N122:74	49275	R	Vyper Drive Run Command Signal Status	
9275	N122:75	49276	R	Vyper Drive No Faults Present Signal Status	
9276	N122:76	49277	R	Vyper Drive Run Acknowledge Relay Status	
9277	N122:77	49278	R	Vyper Drive Run Command Relay Status	
9278	N122:78	49279	R	Vyper Drive Interface Board Software Version	
9279	N122:79	49280	R	Vyper Drive Software Version	
9280	N122:80	49281	R	Vyper Drive Modbus Node ID	
9281	N122:81	49282	R	Vyper Drive IB Transmit Errors	
9282	N122:82	49283	R	Vyper Drive CP to IB Time Out Errors	

VSD (VYPER) SETPOINT VALUES: (Continued)

Frick® Address	AB Address	Modbus Address	Read/Write	Description of Data	Units
9283	N122:83	49284	R	Vyper Drive VD to IB Time Out Errors	None
9284	N122:84	49285	R	Vyper Drive IB to VD Receive Errors	
9285	N122:85	49286	R	Vyper Drive VD to IB Checksum Errors	
9286	N122:86	49287	R	Vyper Drive HF to IB Time Out Errors	
9287	N122:87	49288	R	Vyper Drive VD to HF Receive Errors	
9288	N122:88	49289	R	Vyper Drive HF to IB Checksum Errors	
9289	N122:89	49290	R	Vyper Drive Software Reboots	
9290	N122:90	49291	R	Vyper Drive Phase B Baseplate Temperature	Temperature
9291	N122:91	49292	R	Vyper Drive Phase C Baseplate Temperature	
9295	N122:95	49296	R	Vyper Drive Fault #1	
9296	N122:96	49297	R	Vyper Drive Warning #1	
9297	N122:97	49298	R	Vyper Drive Fault #2	
9298	N122:98	49299	R	Vyper Drive Warning #2	
9299	N122:99	49300	R	Vyper Drive Fault #3	
9300	N123:00	49301	R	Vyper Drive Warning #3	
9301	N123:01	49302	R	Vyper Drive Fault #4	
9302	N123:02	49303	R	Vyper Drive Warning #4	
9303	N123:03	49304	R	Vyper Drive Fault #5	
9304	N123:04	49305	R	Vyper Drive Warning #5	
9305	N123:05	49306	R	Vyper Drive Fault #6	
9306	N123:06	49307	R	Vyper Drive Warning #6	
9307	N123:07	49308	R	Vyper Drive Fault #7	
9308	N123:08	49309	R	Vyper Drive Warning #7	
9309	N123:09	49310	R	Vyper Drive Fault #8	
9310	N123:10	49311	R	Vyper Drive Warning #8	
9311	N123:11	49312	R	Vyper Drive Fault #9	
9312	N123:12	49313	R	Vyper Drive Warning #9	
9313	N123:13	49314	R	Vyper Drive Fault #10	
9314	N123:14	49315	R	Vyper Drive Warning #10	

## WARNING/SHUTDOWN MESSAGE CODES

The following list represents all of the current warning/shutdown messages that are potentially displayable. The numeric value to the left of each message corresponds to the value that is read from the Safety Message addresses (Frick address 3070 – 3079). As an

example, if Frick address 3070 were being read, and it returned a value of 51, then referring to the chart on the following pages, it would be found that the code of 51 represents Oil Level Shutdown.

3	Balance Piston 1 Shutdown	39	Regulation Mode 2 Warning
4	Balance Piston 2 Shutdown	40	Regulation Mode 3 Shutdown
5	Balance Piston 3 Shutdown	41	Regulation Mode 3 Warning
6	Liquid Slugging Warning	42	Regulation Mode 4 Shutdown
7	Liquid Slugging Shutdown	43	Regulation Mode 4 Warning
8	High Oil Filter Pressure Warning	44	Low RPM Shutdown
9	High Oil Filter Pressure Shutdown	45	Low RPM Warning
10	Missing Comp. Oil Pressure Warning	46	High RPM Shutdown
11	Missing Comp. Oil Pressure Shutdown A	47	High RPM Warning
12	Missing Comp. Oil Pressure Shutdown B	48	High Manifold Pressure Shutdown
13	Insufficient Main Oil Pressure Shutdown	49	High Manifold Pressure Warning
14	High Motor Current Shutdown	50	Low Main Oil Injection Pressure Shutdown
15	High Motor Current Warning	51	Oil Level Shutdown
16	Low Motor Current Shutdown	52	Compressor Capacity Unload Alarm
17	High Discharge Temperature Sensor Fault	53	False Running Fail -- Motor Amps
18	High Discharge Temperature Shutdown	54	False Running Fail -- Confirmed Running Inp
19	High Discharge Temperature Warning	55	High Limit Disch Pres Shutdown
20	High Suction Pressure Shutdown	56	High Limit Disch Temp Shutdown
21	High Suction Pressure Warning	57	High Disch Pres Shutdown -- Mode 1
22	Low Separator Temperature Shutdown	58	High Disch Pres Warning -- Mode 1
23	Low Separator Temperature Warning	59	High Disch Pres Shutdown -- Mode 2
24	High Comp. Oil Temperature Shutdown	60	High Disch Pres Warning -- Mode 2
25	High Comp. Oil Temperature Warning	61	Start Failure Shutdown For Eng And Turb
26	Low Comp. Oil Temperature Shutdown	62	High Liquid Level Shutdown
27	Low Comp. Oil Temperature Warning	63	Auxiliary Input 1 Shutdown
28	Low Suction Shutdown - Regulation Mode 1	64	Auxiliary Input 1 Warning
29	Low Suction Warning - Regulation Mode 1	65	Auxiliary Input 2 Shutdown
30	Low Suction Shutdown - Regulation Mode 2	66	Auxiliary Input 2 Warning
31	Low Suction Warning - Regulation Mode 2	67	Auxiliary Input 3 Shutdown
32	Low Suction Shutdown - Regulation Mode 3	68	Auxiliary Input 3 Warning
33	Low Suction Warning - Regulation Mode 3	69	Auxiliary Input 4 Shutdown
34	Low Suction Shutdown - Regulation Mode 4	70	Auxiliary Input 4 Warning
35	Low Suction Warning - Regulation Mode 4	71	Auxiliary Input 5 Shutdown
36	Regulation Mode 1 Shutdown	72	Auxiliary Input 5 Warning
37	Regulation Mode 1 Warning	73	Auxiliary Input 6 Shutdown
38	Regulation Mode 2 Shutdown	74	Auxiliary Input 6 Warning

### WARNING/SHUTDOWN MESSAGE CODES (Continued)

75	Auxiliary Input 7 Shutdown	115	High Auxiliary Analog 9 Shutdown
76	Auxiliary Input 7 Warning	116	High Auxiliary Analog 9 Warning
77	Auxiliary Input 8 Shutdown	117	Low Auxiliary Analog 9 Shutdown
78	Auxiliary Input 8 Warning	118	Low Auxiliary Analog 9 Warning
79	Auxiliary Input 9 Shutdown	119	High Auxiliary Analog 10 Shutdown
80	Auxiliary Input 9 Warning	120	High Auxiliary Analog 10 Warning
81	Auxiliary Input 10 Shutdown	121	Low Auxiliary Analog 10 Shutdown
82	Auxiliary Input 10 Warning	122	Low Auxiliary Analog 10 Warning
83	High Auxiliary Analog 1 Shutdown	123	Low Suction Pressure Sensor Fault
84	High Auxiliary Analog 1 Warning	124	Low Discharge Pressure Sensor Fault
85	Low Auxiliary Analog 1 Shutdown	125	High Discharge Pressure Sensor Fault
86	Low Auxiliary Analog 1 Warning	126	Low Comp. Oil Pressure Sensor Fault
87	High Auxiliary Analog 2 Shutdown	127	High Comp. Oil Pressure Sensor Fault
88	High Auxiliary Analog 2 Warning	128	Low Discharge Temperature Sensor Fault
89	Low Auxiliary Analog 2 Shutdown	129	Low Comp. Oil Temperature Sensor Fault
90	Low Auxiliary Analog 2 Warning	130	Low Separator Temperature Sensor Fault
91	High Auxiliary Analog 3 Shutdown	131	Auxiliary Input 11 Shutdown
92	High Auxiliary Analog 3 Warning	132	Auxiliary Input 11 Warning
93	Low Auxiliary Analog 3 Shutdown	133	Auxiliary Input 12 Shutdown
94	Low Auxiliary Analog 3 Warning	134	Auxiliary Input 12 Warning
95	High Auxiliary Analog 4 Shutdown	134	Auxiliary Input 13 Shutdown
96	High Auxiliary Analog 4 Warning	136	Auxiliary Input 13 Warning
97	Low Auxiliary Analog 4 Shutdown	137	Auxiliary Input 14 Shutdown
98	Low Auxiliary Analog 4 Warning	138	Auxiliary Input 14 Warning
99	High Auxiliary Analog 5 Shutdown	139	Auxiliary Input 15 Shutdown
100	High Auxiliary Analog 5 Warning	140	Auxiliary Input 15 Warning
101	Low Auxiliary Analog 5 Shutdown	141	Auxiliary Input 16 Shutdown
102	Low Auxiliary Analog 5 Warning	142	Auxiliary Input 16 Warning
103	High Auxiliary Analog 6 Shutdown	143	Auxiliary Input 17 Shutdown
104	High Auxiliary Analog 6 Warning	144	Auxiliary Input 17 Warning
105	Low Auxiliary Analog 6 Shutdown	145	Auxiliary Input 18 Shutdown
106	Low Auxiliary Analog 6 Warning	146	Auxiliary Input 18 Warning
107	High Auxiliary Analog 7 Shutdown	147	Auxiliary Input 19 Shutdown
108	High Auxiliary Analog 7 Warning	148	Auxiliary Input 19 Warning
109	Low Auxiliary Analog 7 Shutdown	149	Auxiliary Input 20 Shutdown
110	Low Auxiliary Analog 7 Warning	150	Auxiliary Input 20 Warning
111	High Auxiliary Analog 8 Shutdown	151	High Auxiliary Analog 11 Shutdown
112	High Auxiliary Analog 8 Warning	152	High Auxiliary Analog 11 Warning
113	Low Auxiliary Analog 8 Shutdown	153	Low Auxiliary Analog 11 Shutdown
114	Low Auxiliary Analog 8 Warning	154	Low Auxiliary Analog 11 Warning

**WARNING/SHUTDOWN MESSAGE CODES (Continued)**

155	High Auxiliary Analog 12 Shutdown	195	DBS Communication Failure Shutdown
156	High Auxiliary Analog 12 Warning	196	Digital Board 1 Reset
157	Low Auxiliary Analog 12 Shutdown	197	Digital Board 2 Reset
158	Low Auxiliary Analog 12 Warning	198	Starting Failure - No Compressor Auxiliary
159	High Auxiliary Analog 13 Shutdown	199	Starting Failure - Low Motor Amps
160	High Auxiliary Analog 13 Warning	200	VSD Communication Failure Warning
161	Low Auxiliary Analog 13 Shutdown	201	Low Comp. Oil Pressure Shutdown
162	Low Auxiliary Analog 13 Warning	202	Oil Pump Auxiliary Failure
163	High Auxiliary Analog 14 Shutdown	203	Oil Pump 1 Auxiliary Warning
164	High Auxiliary Analog 14 Warning	204	Oil Pump 1 Auxiliary Shutdown
165	Low Auxiliary Analog 14 Shutdown	205	Oil Pump 2 Auxiliary Warning
166	Low Auxiliary Analog 14 Warning	206	Oil Pump 2 Auxiliary Shutdown
167	High Auxiliary Analog 15 Shutdown	207	Low Comp. Oil Pressure Warning
168	High Auxiliary Analog 15 Warning	208	Low Comp. Oil Pressure Shutdown
169	Low Auxiliary Analog 15 Shutdown	209	Low Oil Pressure Shutdown 2
170	Low Auxiliary Analog 15 Warning	210	High Compressor Vib Warning - Suction
171	High Auxiliary Analog 16 Shutdown	211	High Compressor Vib Warning - Discharge
172	High Auxiliary Analog 16 Warning	212	High Compressor Vib Shutdown - Suction
173	Low Auxiliary Analog 16 Shutdown	213	High Compressor Vib Shutdown - Discharge
174	Low Auxiliary Analog 16 Warning	214	High Motor Vib Warning - Shaft Side
175	High Auxiliary Analog 17 Shutdown	215	High Motor Vib Warning - Opp Shaft Side
176	High Auxiliary Analog 17 Warning	216	High Motor Vib Shutdown - Shaft Side
177	Low Auxiliary Analog 17 Shutdown	217	High Motor Vib Shutdown - Opp Shaft Side
178	Low Auxiliary Analog 17 Warning	218	Compressor Auxiliary Shutdown
179	High Auxiliary Analog 18 Shutdown	220	Oil Log Shutdown
180	High Auxiliary Analog 18 Warning	221	DBS - Current Unbalance
181	Low Auxiliary Analog 18 Shutdown	222	DBS - RTD Temperature
182	Low Auxiliary Analog 18 Warning	223	DBS - Short Circuit
183	High Auxiliary Analog 19 Shutdown	224	DBS - Thermal Overload
184	High Auxiliary Analog 19 Warning	225	DBS - Shorted SCR
185	Low Auxiliary Analog 19 Shutdown	226	DBS - Phase Loss
186	Low Auxiliary Analog 19 Warning	227	DBS - Phase Reversal
187	High Auxiliary Analog 20 Shutdown	228	DBS - Jam
188	High Auxiliary Analog 20 Warning	229	DBS - HEATSINK Overtemperature
189	Low Auxiliary Analog 20 Shutdown	230	DBS - RTD Overtemperature
190	Low Auxiliary Analog 20 Warning	231	VSD Board Power Supply Fault
191	Analog Board 1 Communications Shutdown	233	VSD Board Motor Current > 15%
192	Analog Board 2 Communications Shutdown	234	VSD Board Run Signal Fault
193	Digital Board 1 Communications Shutdown	235	VSD Board to Panel Comms Loss
194	Digital Board 2 Communications Shutdown	237	VSD Initialization Fault

### WARNING/SHUTDOWN MESSAGE CODES (Continued)

238	VSD Stop Contacts Fault	296	Harmonic Filter Precharge - Low DC Bus Volt
239	Harmonic Filter Logic Board Or Comms Fault	297	Harmonic Filter DC Current Transformer 1
240	Harmonic Filter High Total Demand Distortion	298	Harmonic Filter DC Current Transformer 2
241	VSD High Phase B Inverter Baseplate Temp	299	Harmonic Filter High Baseplate Temp Fault
242	VSD High Phase C Inverter Baseplate Temp	301	Harmonic Filter Low DC Bus Voltage
243	VSD Low Phase B Inverter Baseplate Temp	305	Harmonic Filter DC Bus Voltage Imbalance
244	VSD Low Phase C Inverter Baseplate Temp	306	Harmonic Filter 110% Input Current Overload
247	VSD High Phase A Instantaneous Current	307	Harmonic Filter Run Signal Fault
248	VSD High Phase B Instantaneous Current	311	VSD Board NovRAM Failure
249	VSD High Phase C Instantaneous Current	313	Harmonic Filter Serial Communication
251	VSD Phase A Gate Driver Fault	314	Harmonic Filter Input Frequency Out of Range
252	VSD Phase B Gate Driver Fault	331	VSD High Phase A Inverter Baseplate Temp
253	VSD Phase C Gate Driver Fault	332	VSD Low Phase A Inverter Baseplate Temp
254	VSD Single Phase Input Power Fault	333	High Discharge Pressure Shutdown
257	VSD 105% Motor Current Overload Fault	334	High Discharge Pressure Warning
258	VSD High DC Bus Voltage Fault	335	Process Stopped - See Event Log
259	VSD Logic Board Power Supply Fault	336	High Process Entering Temp Shutdown
263	VSD Low DC Bus Voltage Fault	337	High Process Entering Temp Warning
264	VSD DC Bus Voltage Imbalance Fault	338	Low Process Entering Temp Shutdown
265	VSD High Internal Ambient Temp Fault	339	Low Process Entering Temp Warning
266	VSD High Inverter Baseplate Temp Fault	340	High Motor Temp Warning - Shaft Side
267	VSD Logic Board Processor Fault	341	High Motor Temp Warning - Opp Shaft Side
268	VSD Run Signal Fault	342	High Motor Temp Shutdown - Shaft Side
269	VSD High Converter Heatsink Temp Fault	343	High Motor Temp Shutdown - Opp Shaft Side
270	VSD Invalid Current Scale Selection	344	High Motor Stator #1 Temp Warning
271	VSD Low Inverter Baseplate Temp Fault	345	High Motor Stator #1 Temp Shutdown
272	VSD Serial Communication Fault	346	High Motor Stator #2 Temp Warning
273	VSD Precharge Lockout Fault	347	High Motor Stator #2 Temp Shutdown
274	VSD Low Converter Heatsink Temp Fault	348	High Motor Stator #3 Temp Warning
275	VSD Current Imbalance Fault	349	High Motor Stator #3 Temp Shutdown
276	VSD Precharge - DC Bus Voltage Imbalance	350	Slide Valve Failure Shutdown
277	VSD Precharge - Low DC Bus Voltage 2	351	DBS Communication Failure Warning
278	VSD Precharge - Low DC Bus Voltage 1	352	Low Oil Differential 1 (Kobe)
280	Harmonic Filter High DC Bus Voltage Fault	353	Low Oil Differential 2 (Kobe)
281	Harmonic Filter High Phase C Current Fault	354	High Oil Pressure (Kobe)
282	Harmonic Filter High Phase B Current Fault	355	High Comp. Oil Pressure Shutdown
283	Harmonic Filter High Phase A Current Fault	356	Coalescer Filter Differential Warning
284	Harmonic Filter Phase Locked Loop Fault	357	Low Discharge Pressure Shutdown
286	Harmonic Filter Logic Board Power Supply	358	High Oil Temperature Sensor Fault
295	Harmonic Filter Precharge - High DC Bus Volt	359	High Separator Temperature Sensor Fault

**WARNING/SHUTDOWN MESSAGE CODES (Continued)**

360	Low Main Oil Inj Pressure Sensor Warning	372	Low Suction Temp Sensor Warning
361	High Main Oil Inj Pressure Sensor Warning	373	High Suction Temp Sensor Warning
362	Low Economizer Pressure Sensor Warning	374	Low Disch Temp Sensor Warning
363	High Economizer Pressure Sensor Warning	375	High Disch Temp Sensor Warning
364	Low Filter Pressure Sensor Warning	376	Low Oil Temp Compressor Sensor Warning
365	High Filter Pressure Sensor Warning	377	High Oil Temp Compressor Sensor Warning
366	Low Intermediate Pressure Sensor Warning	378	Low Oil Separator Temp Sensor Warning
367	High Intermediate Pressure Sensor Warning	379	High Oil Separator Temp Sensor Warning
368	Low Bal Piston Pressure Sensor Warning	380	Low Intermediate Temp Sensor Warning
369	High Bal Piston Pressure Sensor Warning	381	High Intermediate Temp Sensor Warning
370	Low System Disch Pressure Sensor Warning	382	Low Process Leaving Temp Sensor Warning
371	High System Disch Pressure Sensor Warning	383	High Process Leaving Temp Sensor Warning
384	Low Process Entering Temp Sensor Warning	387	High External Temp Sensor Warning
385	High Process Entering Temp Sensor Warning	388	Low Refrigerant Liquid Temp Sensor Warning
386	Low External Temp Sensor Warning	389	High Refrigerant Liquid Temp Sensor Warning
390	Low Inlet Condenser Temp Sensor Warning	415	High Auxiliary Analog Input #2 Sensor Warning
391	High Inlet Condenser Temp Sensor Warning	416	Low Auxiliary Analog Input #3 Sensor Warning
392	Low Outlet Condenser Temp Sensor Warning	417	High Auxiliary Analog Input #3 Sensor Warning
393	High Outlet Condenser Temp Sensor Warning	418	Low Auxiliary Analog Input #4 Sensor Warning
394	Low Economizer Gas Temp Sensor Warning	419	High Auxiliary Analog Input #4 Sensor Warning
395	High Economizer Gas Temp Sensor Warning	420	Low Auxiliary Analog Input #5 Sensor Warning
396	Low Motor Cooling Media Temp Sensor Warning	421	High Auxiliary Analog Input #5 Sensor Warning
397	High Motor Cooling Media Temp Sensor Warning	422	Low Auxiliary Analog Input #6 Sensor Warning
398	Low Seq Temp Cont Feedback Sensor Warning	423	High Auxiliary Analog Input #6 Sensor Warning
399	Low Seq Temp Cont Feedback Sensor Warning	424	Low Auxiliary Analog Input #7 Sensor Warning
400	Low Thermistor In Motor Sensor Warning	425	High Auxiliary Analog Input #7 Sensor Warning
401	High Thermistor In Motor Sensor Warning	426	Low Auxiliary Analog Input #8 Sensor Warning
402	Low Ext Setpt/Ext Inp Sig Sensor Warning	427	High Auxiliary Analog Input #8 Sensor Warning
403	High Ext Setpt/Ext Inp Sig Sensor Warning	428	Low Auxiliary Analog Input #9 Sensor Warning
404	Low Motor Current Sensor Warning	429	High Auxiliary Analog Input #9 Sensor Warning
405	High Motor Current Sensor Warning	430	Low Auxiliary Analog Input #10 Sensor Warning
406	Low RPM Sensor Warning	431	High Auxiliary Analog Input #10 Sensor Warning
407	High RPM Sensor Warning	432	Low Auxiliary Analog Input #11 Sensor Warning
408	Low Kw Monitoring Sensor Warning	433	High Auxiliary Analog Input #11 Sensor Warning
409	High Kw Monitoring Sensor Warning	434	Low Auxiliary Analog Input #12 Sensor Warning
410	Low Condenser Valve Feedback Sensor Warning	435	High Auxiliary Analog Input #12 Sensor Warning
411	High Condenser Valve Feedback Sensor Warning	436	Low Auxiliary Analog Input #13 Sensor Warning
412	Low Auxiliary Analog Input #1 Sensor Warning	437	High Auxiliary Analog Input #13 Sensor Warning
413	High Auxiliary Analog Input #1 Sensor Warning	438	Low Auxiliary Analog Input #14 Sensor Warning
414	Low Auxiliary Analog Input #2 Sensor Warning	439	High Auxiliary Analog Input #14 Sensor Warning

### WARNING/SHUTDOWN MESSAGE CODES (Continued)

440	Low Auxiliary Analog Input #15 Sensor Warning	454	Low Rem Capacity Position Sensor Warning
441	High Auxiliary Analog Input #15 Sensor Warning	455	High Rem Capacity Position Sensor Warning
442	Low Auxiliary Analog Input #16 Sensor Warning	456	Low Liquid Level Sensor Warning
443	High Auxiliary Analog Input #16 Sensor Warning	457	High Liquid Level Sensor Warning
444	Low Auxiliary Analog Input #17 Sensor Warning	458	High Process Leaving Temp Shutdown
445	High Auxiliary Analog Input #17 Sensor Warning	459	High Process Leaving Temp Warning
446	Low Auxiliary Analog Input #18 Sensor Warning	460	Low Process Leaving Temp Shutdown
447	High Auxiliary Analog Input #18 Sensor Warning	461	Low Process Leaving Temp Warning
448	Low Auxiliary Analog Input #19 Sensor Warning	462	Coalescer Filter Differential Warning
449	High Auxiliary Analog Input #19 Sensor Warning	463	Condensing Water In Separator Warning (Off)
450	Low Auxiliary Analog Input #20 Sensor Warning	464	Condensing Water In Separator Warning (Running)
451	High Auxiliary Analog Input #20 Sensor Warning	465	Low Starting Oil Pressure Shutdown (for shaft aux. pump type)
452	Low Manifold Pressure Sensor Warning		
453	High Manifold Pressure Sensor Warning		

## QUANTUM™ 4 MAIN BOARD HISTORY AND IDENTIFICATION

The processor board shown on this page is known as the Quantum™ 4 board, and it is based on the Pentium microprocessor platform. The operating software that this board runs is known as Quantum™ LX software. This software displays graphic information and data on the LCD screen in a format that is similar to the way a Windows® desktop computer screen displays a Web browser (the Internet).

The Quantum™ 4 board can be identified by the presence of a daughter board mounted to the main board. This *daughter board* is the communications portion of the Quantum™ 4, and it can be identified by the presence of an 8 position DIP switch. There are also a number of jumpers (or links) present on this smaller board, as well as three green connectors (RS-232, RS-422 and RS-485 ports). The jumpers are used to set up the communications parameters that are listed on the next page.

The main board (larger of the two) has a number of jumpers (or links) also. The links on this main board MAY

need to be modified by factory qualified personnel to configure the Quantum™ 4 for specific applications.

The Quantum™ 4 utilizes Flash Card technology, as did the Quantum™ 3. There is a Flash Card socket located on the under side of this main board. The Quantum™ 4 board has the LX Operating System pre-loaded at the factory, so this Flash Card feature will primarily be utilized for future program updates.

When calling Frick® Company for service or help, it will greatly assist us if the type of board is known, either Quantum™ 1, 2, 3 or 4. Additionally, Frick® will request the Sales Order number, and the Operating System version number (this can be found on the *About...* screen). The more information you have at the time of the call, the better able we will be to assist you.

The information that follows will primarily describe the jumper configuration for communications settings, as well as wiring diagrams for the different types of communications that are possible with the Quantum™ 4.

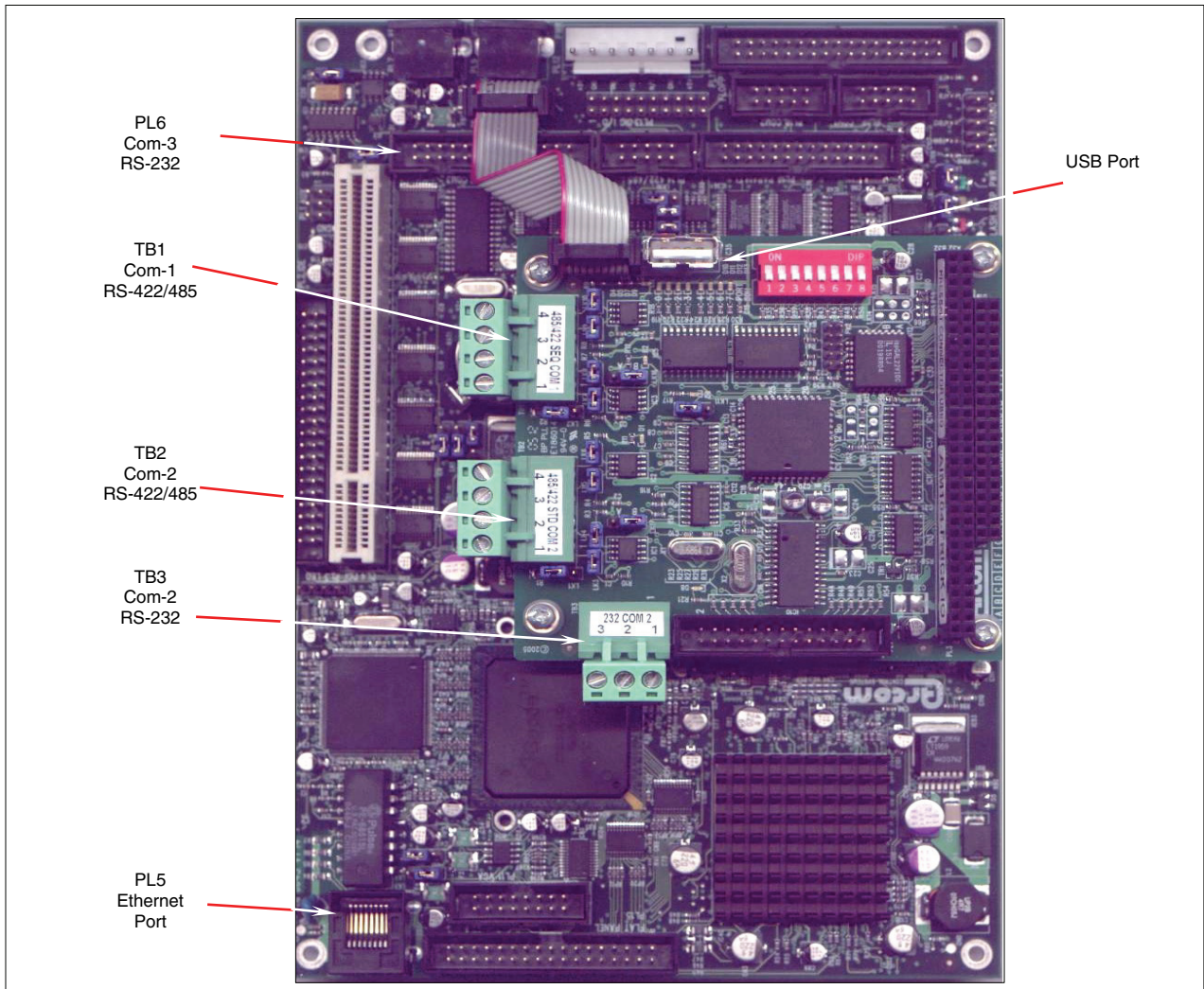

Quantum™ 4 Main and Communications Boards

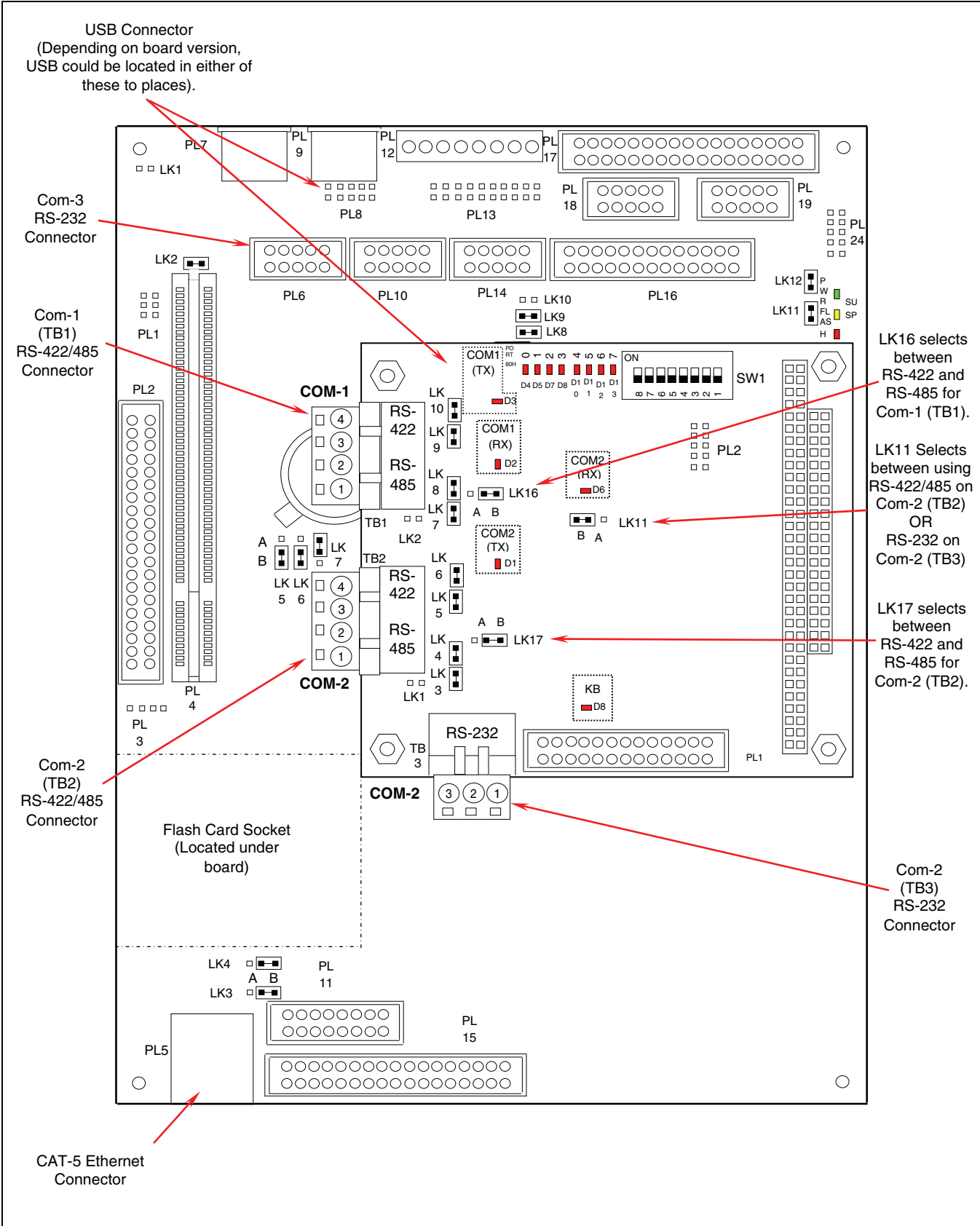

Quantum™ LX Communications Jumpers, connectors and LED locations

## SERIAL COMMUNICATIONS PORT WIRING

### RS-232 WIRING AND JUMPERS

#### COM-2 (TB3)

The following pictorial shows the communications board, as well as the jumpers, LED's and signal pinouts to allow the end user to communicate to Com-2 (TB3) using RS-232 protocol. Refer to the tables in this section for the specifics on the jumper settings and wiring convention for RS-232.

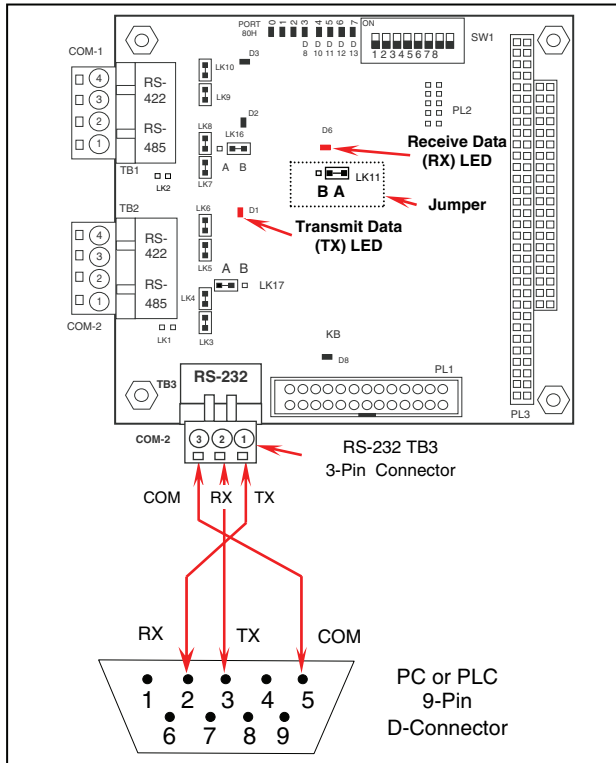

#### RS-232 Com-2, TB3 Communications Board Jumpers

LINK	POSITION	FUNCTION
LK11	A *	Select RS-232 for COM2 (TB3)
	B	Select RS-422 for COM2 (TB2)

\* Standard Setting

#### RS-232 Com-2, TB3 Communications Signals

TB3 Connector Pin #	Signal
1	Transmit Data (TX)
2	Received Data (RX)
3	Ground (COM)

#### COM-3 (PL6)

The following pictorial shows the communications board, as well as the jumpers, LED's and signal pinouts to allow the end user to communicate to Com-3 (PL6) using RS-232 protocol. Refer to the table entitled **Com-3, PL6 Communications Signals** for the specifics on the jumper settings and wiring convention for RS-232. **NOTE:** There are NO jumper settings associated with this connector (Com-3).

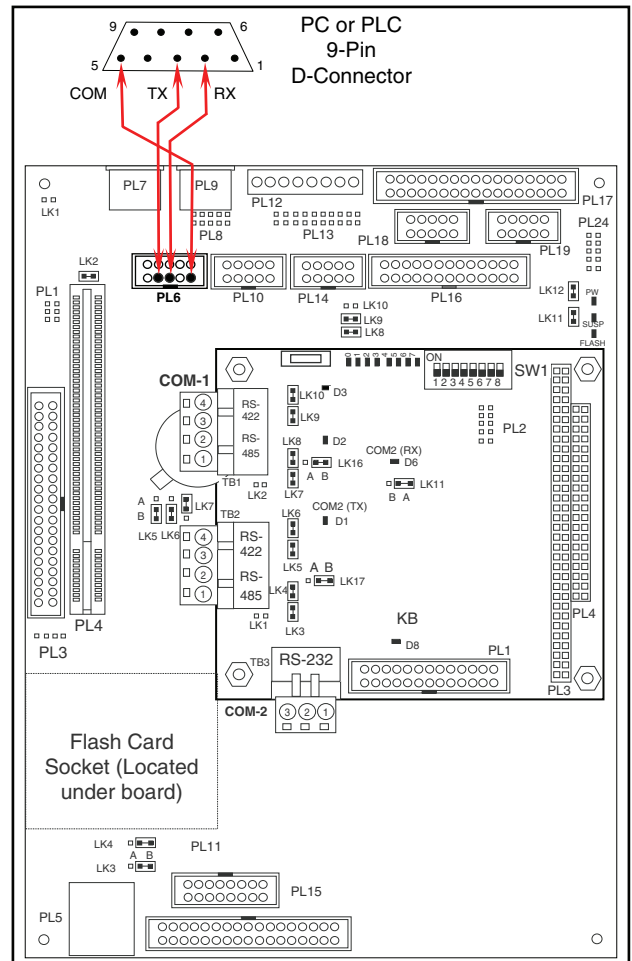

#### RS-232 Com-3 (PL6) Communications Signals

#### RS-232 Com-3, PL6 Communications Signals

PL6 Connector Pin #	Signal
3	Received Data (RX)
5	Transmit Data (TX)
9	Ground (COM)

### RS-422 WIRING AND JUMPERS

The following table describes the Quantum™ RS-422 connector pinouts and their associated communications signals:

#### RS-422 (TB1) Signal Wiring

TB1 Connector Pin #	Signal
4	TX+
3	TX-
2	RX+
1	RX-

#### COM-1 (TB1)

The following pictorial shows the communications board, as well as the jumpers, LED's and signal pinouts to allow the end user to communicate to Com-1 (TB1) using RS-422 protocol. Refer to the tables in this section for the specifics on the jumper settings and wiring convention for RS-422:

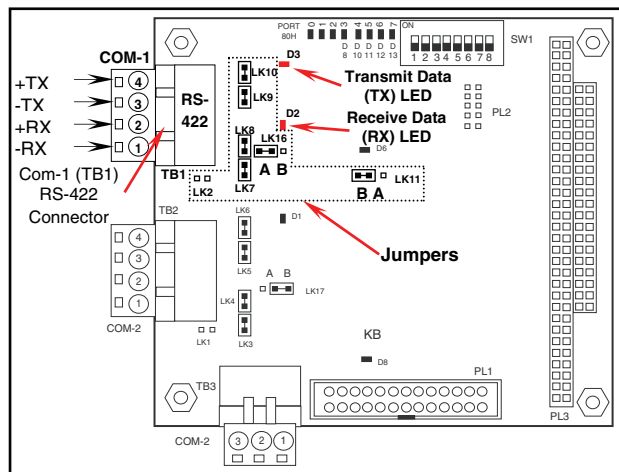

RS-422 Com-1 (TB1) Connector, Jumpers and LED Location

#### RS-422 (TB1) Board Jumpers

LINK	POSITION	FUNCTION
LK2	In Out*	Terminate COM1 No termination RS-422
LK7	In Out*	Pull down COM1 No pull down RS-422 (-RX)
LK8	In Out*	Pull up COM1 No pull up RS-422 (+RX)
LK9	In Out*	Pull down COM1 No pull down RS-422 (-TX)
LK10	In Out*	Pull up COM1 No pull up RS-422 (+TX)
LK16	A * B	COM1 RS-422 (TB1) COM1 RS-485 (TB1)

\* Standard Setting

#### COM-2 (TB2)

The following pictorial shows the communications board, as well as the jumpers, LED's and signal pinouts to allow the end user to communicate to Com-2 (TB2) using RS-422 protocol. Refer to the tables in this section for the specifics on the jumper settings and wiring convention for RS-422:

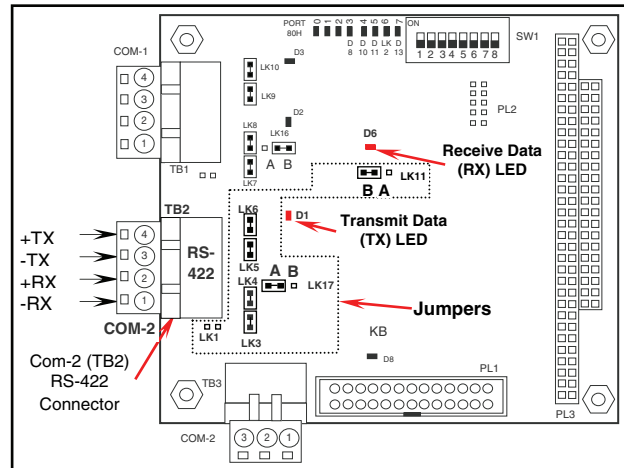

RS-422 Com-2 (TB2) Connector, Jumpers and LED Location

#### RS-422 (TB2) Communications Board Jumpers

LINK	POSITION	FUNCTION
LK 1	In Out*	Terminate COM2 No termination RS-422
LK 3	In Out*	Pull down COM2 No pull down RS-422 (Rx-)
LK 4	In Out*	Pull up COM2 No pull up RS-422 (Rx+)
LK 5	In Out*	Pull down COM2 No pull down RS-422 (Tx-)
LK 6	In Out*	Pull up COM2 No pull up RS-422 (Tx+)
LK 11	A B*	Select RS-232 for COM2 (TB3) Select RS-422 for COM2 (TB2)
LK 17	A * B	COM2 RS-422 (TB2) COM2 RS-485 (TB2)

\* Standard Setting

## RS-485 WIRING AND JUMPERS

The following table describes the Quantum™ RS-485 connector pinouts and their associated communications signals:

### RS-422 (TB1) Communications Signal Wiring

TB1 Connector Pin #	Signal
2	+TX / +RX
1	-TX / -RX

### COM-1 (TB1)

The following pictorial shows the communications board, as well as the jumpers, LED's and signal pinouts to allow the end user to communicate to Com-1 (TB1) using RS-485 protocol. Refer to the tables on this page for the specifics on the jumper settings and wiring convention for RS-485:

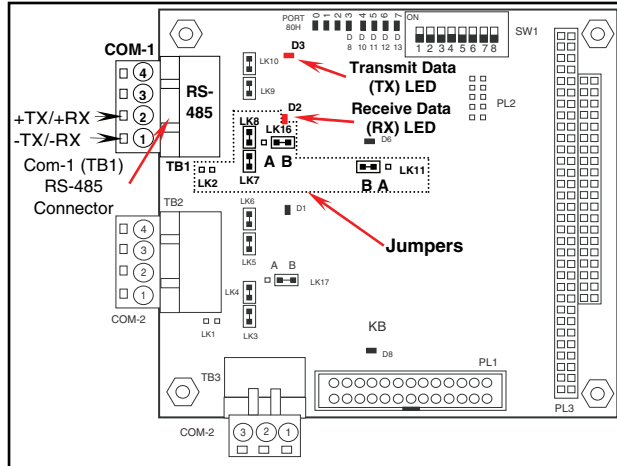

RS-485 Com-1 (TB1) Connector, Jumpers and LED Location

### RS-485 (TB1) Communications Board Jumpers

LINK	POSITION	FUNCTION
LK2	In Out*	Terminate COM1 No termination RS-485
LK7	In Out*	Pull down COM1 No pull down RS-485 (-TX / -RX)
LK8	In Out*	Pull up COM1 No pull up RS-485 (+TX / +RX)
LK16	A B *	COM1 RS-422 (TB1) COM1 RS-485 (TB1)

\* Standard Setting

### COM-2 (TB2)

The following pictorial shows the communications board, as well as the jumpers, LED's and signal pinouts to allow the end user to communicate to Com-2 (TB2) using RS-485 protocol. Refer to the tables in this section for the specifics on the jumper settings and wiring convention for RS-485:

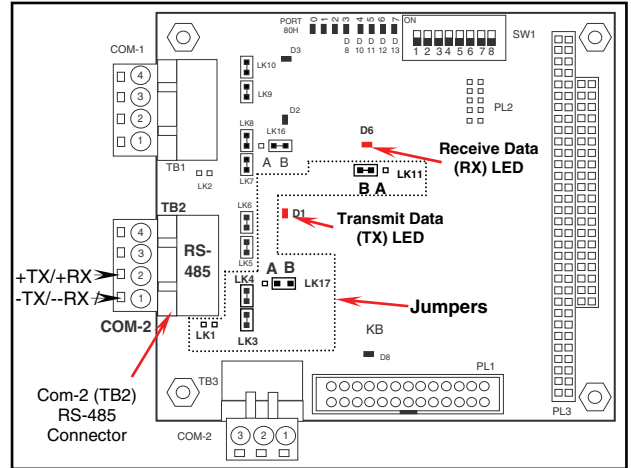

RS-485 Com-2 (TB2) Connector, Jumpers and LED Location

### RS-485 (TB2) Communications Board Jumpers

LINK	POSITION	FUNCTION
LK 1	In Out*	Terminate COM2 No termination RS-485
LK 3	In Out*	Pull down COM2 No pull down RS-485 (-TX / -RX)
LK 4	In Out*	Pull up COM2 No pull up RS-485 (+TX / +RX)
LK 11	A B*	Select RS-232 for COM2 (TB3) Select RS-422 for COM2 (TB2)
LK 17	A * B	COM2 RS-422 (TB2) COM2 RS-485 (TB2)

\* Standard Setting

## SERIAL COMMUNICATIONS TROUBLESHOOTING

**WIRING NOTE:** See the chapter entitled *Serial Communications Port Wiring*, for the pictorials and tables referred to in the following paragraphs. Always ensure that the wiring matches these pictorials before proceeding.

**JUMPER NOTE:** Some of the jumpers in the previous tables may need to be modified for RS-422/485 to ensure optimum communications performance. Typically, the termination jumper should be installed in the last Quantum™ in the communications daisy chain only.

### TROUBLESHOOTING RS-232

#### Com-2 (TB3)

Notice in the figure entitled *RS-232 Com-2 (TB3) Communications Wiring*, the only jumper associated with TB3 Com-2 is jumper LK11. LK11 must be set to the **A** position. Notice also the two LED indicators that are pointed out. D4 LED will flash each time that the Quantum™ transmits (TX) data. D6 LED will flash each time that data is received (RX).

If communications cannot be established using TB3, then note the status of these two LED's (D4 and D6). If D6 is constantly lit, it may indicate an external wiring issue (TX and RX possibly swapped). Also verify the position of LK11, and ensure that it is in position **A**.

Also verify that the proper Panel ID, Baud rate, data bits, and protocol has been setup at the Quantum™, and matches that of the initiating device (see the section entitled *COMMUNICATIONS SETUP* for further details).

#### Com-3 (PL6)

Notice in the figure entitled *RS-232 Com-3 (PL6) Wiring to 9-Pin D-Connector*, there are no jumpers or LED's associated with PL6 Com-3.

If communications cannot be established using PL6, verify that the wiring is per the figure when wired direct from a remote RS-232 port.

Also verify that the proper Panel ID, Baud rate, data bits, and protocol has been setup at the Quantum™, and matches that of the initiating device (see the section entitled *COMMUNICATIONS SETUP* for further details).

### TROUBLESHOOTING RS-422

#### Com-1 (TB1)

Notice that in the figure entitled *RS-422 Com-1 (TB1) Connector, Jumpers & LED Location* that there are seven jumpers associated with TB1. Refer to the table entitled *RS-422 (TB1) Board Jumpers* for the function of each of these jumpers. **Note:** LK11 must be set to position **B**, and LK17 must be set to position **A**. Notice also the two LED indicators that are in the figure. D3 LED will flash each time that the Quantum™ 4 transmits (TX) data. D2 LED will flash each time that data is received (RX).

If communications with the Quantum™ 4 cannot be established using TB1, then note the status of these two LED's (D2 and D3). If D2 is constantly lit, it may indicate an external wiring issue (TX and RX possibly swapped). If D2 never flashes, then the LX is not receiving any data. If D2 does flash each time a data bit is received, but D3 never flashes, this may indicate that the LX has received a data command, but that the protocol package is not properly formatted, and the LX cannot respond.

On the *Communications Setup* screen, verify that the proper Panel ID, Baud rate, data bits, and protocol has been setup at the Quantum™ LX, and matches that of the initiating device. Ensure that the RS-485 pull down menu selection has been properly set to **No**, as shown here:

- **No** = RS-422
- **Yes** = RS-485

#### Com-2 (TB2)

Notice that in the figure entitled *RS-422 Com-2 (TB2) Connector, Jumpers & LED Location*, there are seven jumpers associated with TB2. Refer to the table entitled *RS-422 (TB2) Board Jumpers* for the function of each of these jumpers. **Note:** LK11 must be set to position **B**, and LK17 must be set to position **A**. Notice also the two LED indicators that are pointed out in the figure. D1 LED will flash each time that the Quantum™ 4 transmits (TX) data. D6 LED will flash each time that data is received (RX).

If communications with the Quantum™ 4 cannot be established using TB2, then note the status of these two LED's (D1 and D6). If D1 is constantly lit, it may indicate an external wiring issue (TX and RX possibly swapped). If D6 never flashes, then the LX is not receiving any data. If D6 does flash each time a data bit is received, but D1

never flashes, this may indicate that the LX has received a data command, but that the protocol package is not properly formatted, and the LX cannot respond.

On the *Communications Setup* screen, verify that the proper Panel ID, Baud rate, data bits, and protocol has been setup at the Quantum™ LX, and matches that of the initiating device.

## TROUBLESHOOTING RS-485

### Com-2 (TB1)

Notice that in the figure entitled *RS-485 Com-1 (TB1) Connector, Jumpers & LED Location*, there are seven jumpers associated with TB1. Refer to the table entitled *RS-485 (TB1) Board Jumpers* for the function of each of these jumpers. **Note:** LK11 must be set to position *B*, and LK17 must be set to position *A*. Notice also the two LED indicators that are pointed out in the figure. D3 LED will flash each time that the Quantum™ 4 transmits (TX) data. D2 LED will flash each time that data is received (RX).

If communications with the Quantum™ 4 cannot be established using TB1, then note the status of these two LED's (D2 and D3). If D2 is constantly lit, it may indicate an external wiring issue (TX and RX possibly swapped). If D2 never flashes, then the LX is not receiving any data. If D2 does flash each time a data bit is received, but D3 never flashes, this may indicate that the LX has received a data command, but that the protocol package is not properly formatted, and the LX cannot respond.

On the *Communications Setup* screen, verify that the proper Panel ID, Baud rate, data bits, and protocol has been setup at the Quantum™ LX, and matches that of the initiating device.

### Com-2 (TB2)

Notice that in the figure entitled *RS-485 Com-2 (TB2) Connector, Jumpers & LED Location*, there are seven jumpers associated with TB2. Refer to table entitled *RS-485 (TB2) Board Jumpers* for the function of each of these jumpers. **Note:** LK11 must be set to position *B*, and LK17 must be set to position *A*. Notice also the two LED indicators that are pointed out in the figure. D1 LED will flash each time that the Quantum™ 4 transmits (TX) data. D6 LED will flash each time that data is received (RX).

If communications with the Quantum™ 4 cannot be established using TB2, then note the status of these two LED's (D1 and D6). If D1 is constantly lit, it may indicate an external wiring issue (TX and RX possibly swapped). If D6 never flashes, then the LX is not receiving any data. If D6 does flash each time a data bit is received, but D1 never flashes, this may indicate that the LX has received a data command, but that the protocol package is not properly formatted, and the LX cannot respond.

On the *Communications Setup* screen, verify that the proper Panel ID, Baud rate, data bits, and protocol has been setup at the Quantum™ LX, and matches that of the initiating device.

## COMMUNICATIONS DATA LOGGING SCREENS

### SERVICE – Communications Log



### SERVICE – ModBus TCP Log

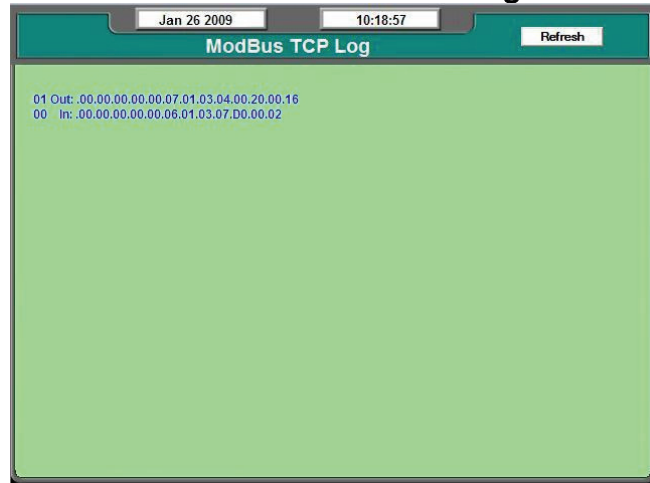

**ACCESSING:**

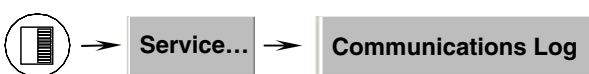

**DESCRIPTION:** This screen allows the technician to view the status of all serial communications ports, or the status of all Modbus TCP communications. Refer to the section entitled Modbus TCP Log in the Modbus Protocol chapter.

**ACCESSING:**



**DESCRIPTION:** This screen allows the technician to view the status of all Modbus TCP communications. Refer to the section entitled Modbus TCP Log in the Modbus Protocol chapter.

The following user selectable buttons are provided:

- [Show Comm1]
- [Show Comm2]
- [Show Comm3]
- [Show Comm4]

This screen allows the technician to view all of the serial communications information that the Quantum™ LX is receiving and transmitting, one port at a time. Simply select the button at the upper right side of the screen that corresponds to the port that you wish to view. The selected port name (in this case Comm4) will appear in the upper left side of the screen.

Each time a new command is sent or received, the screen will need to be refreshed by selecting the [Show Comm $X$ ] button (where  $X$  is replaced with the comm port number).

The top line of data is the most recent activity. At the left of each line, you should see whether the data is *IN* or *OUT* (Receive or Send), and the actual data (in Hexadecimal format). This information can be used to compare against the data being sent and received at the other end of the communications link, to verify proper operation. Refer to the section on Hyperterminal for some examples of how this screen may be used.

The following user selectable button is provided:

[Refresh]

This screen allows the technician to view all of the Modbus TCP communications information that the Quantum™ LX is receiving and transmitting.

Each time a new command is sent or received, the screen will need to be refreshed by selecting the [Refresh] button.

The top line of data is the most recent activity. At the left of each line, you should see whether the data is *IN* or *OUT* (Receive or Send), and the actual data (in Hexadecimal format). This information can be used to compare against the data being sent and received at the other end of the communications link, to verify proper operation.

**NOTE:** Refer to the section entitled Modbus TCP Log in the Modbus Protocol chapter for additional information.

## COMMUNICATIONS LOOPBACK TEST

### DESCRIPTION

The purpose of this section is to verify the proper operation of the following communications ports:

- Comms 1 (TB1) and 2 (TB2) - RS-422
- Comms 1 (TB1) and 2 (TB2) - RS-485
- Comms 2 (TB2) and 3 (PL6) - RS-232

By utilizing a loopback test harness (as shown below), the technician has the ability to locally test the Quantum™ communications hardware and jumper configuration.

### HARDWARE SETUP FOR TESTING RS-232

To create the communications loopback harness for RS-232 testing, use the following example:

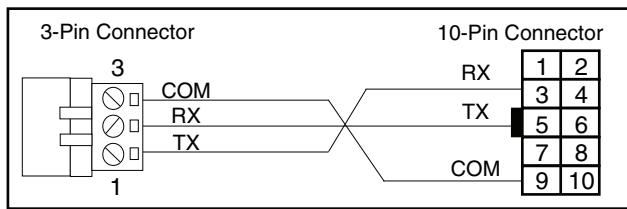

**RS-232 Test Harness**

Set the communications jumpers as follows:

- Set LK11 to position **A**
- Plug the RS-232 test harness (as shown above) into the com ports at TB3 and PL6.

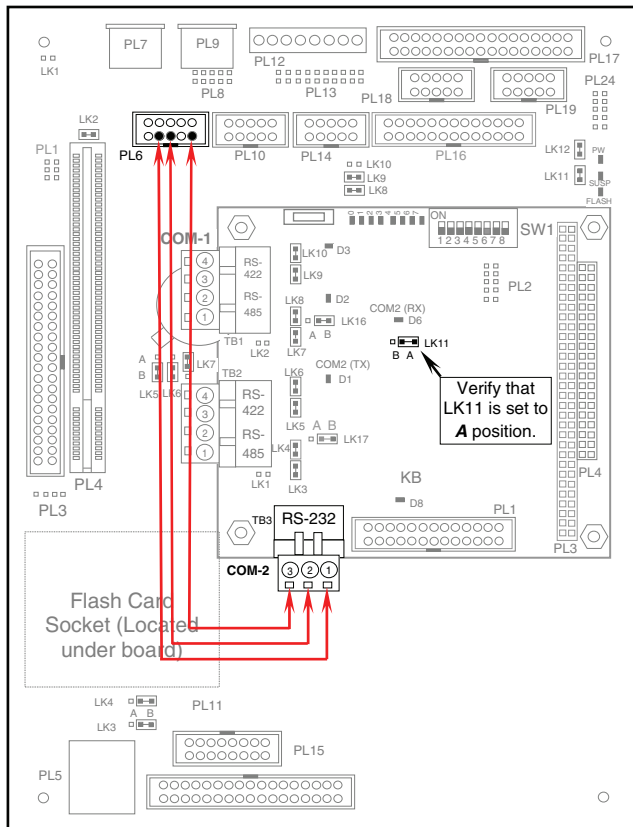

**Com-2 (TB3) & Com-3 (PL6) RS-232 Connector & Jumper Location**

### HARDWARE SETUP FOR TESTING RS-422

To create the communications loopback harness for RS-422 testing, use the following example:

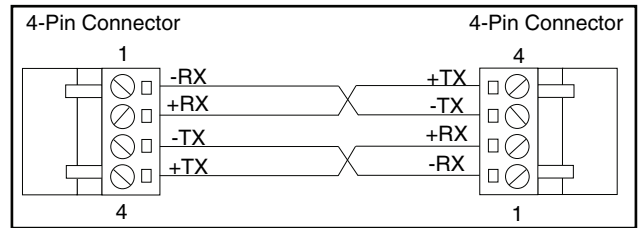

**RS-422 Test Harness**

Set the Quantum™ communications jumpers as follows:

- Set LK11 to position **B**
- Set LK16 to position **A**
- Set LK17 to position **A**
- Plug the RS-422 test harness (as shown above) into the com ports at TB1 and TB2 as shown here:

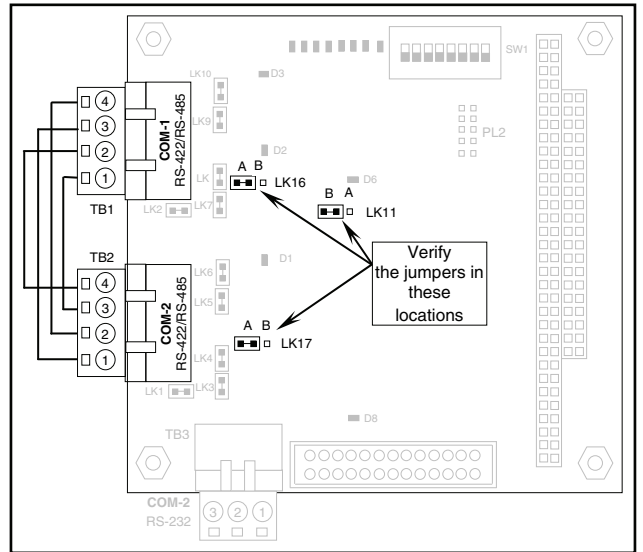

**RS-422 Test Configuration**

### HARDWARE SETUP FOR TESTING RS-485

To create the communications loopback harness for RS-485 testing, use the following example:

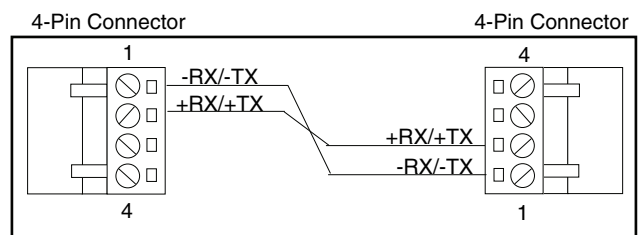

**RS-485 Test Harness**

Set the Quantum™ communications jumpers as follows:

- Set LK11 to position *B*
- Set LK16 to position *B*
- Set LK17 to position *B*
- Plug the RS-485 test harness (as shown above) into the com ports at TB1 and TB2 as shown here:

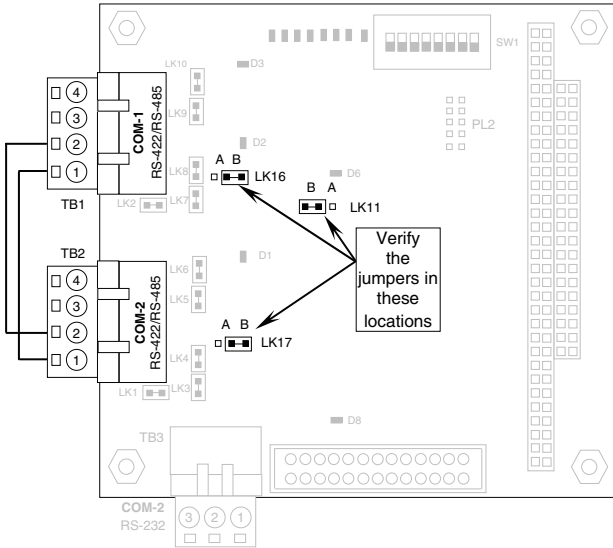

RS-485 Test Configuration

### SOFTWARE SETUP FOR THE COMMUNICATIONS LOOPBACK TEST

On the *Communications* screen (shown below), ensure that the settings are as follows:

- **Compressor ID:** 0 - 255 (does not matter)
- **Comm Baud Rate:** Does not matter, but all Comms to be tested must be set the same.
- **Data Bits:** Does not matter, but all Comms to be tested must be set the same.
- **Stop Bits:** Does not matter, but all Comms to be tested must be set the same.
- **Parity:** Does not matter, but all Comms to be tested must be set the same.
- **Protocol:** Set all Comms to be tested to Frick.

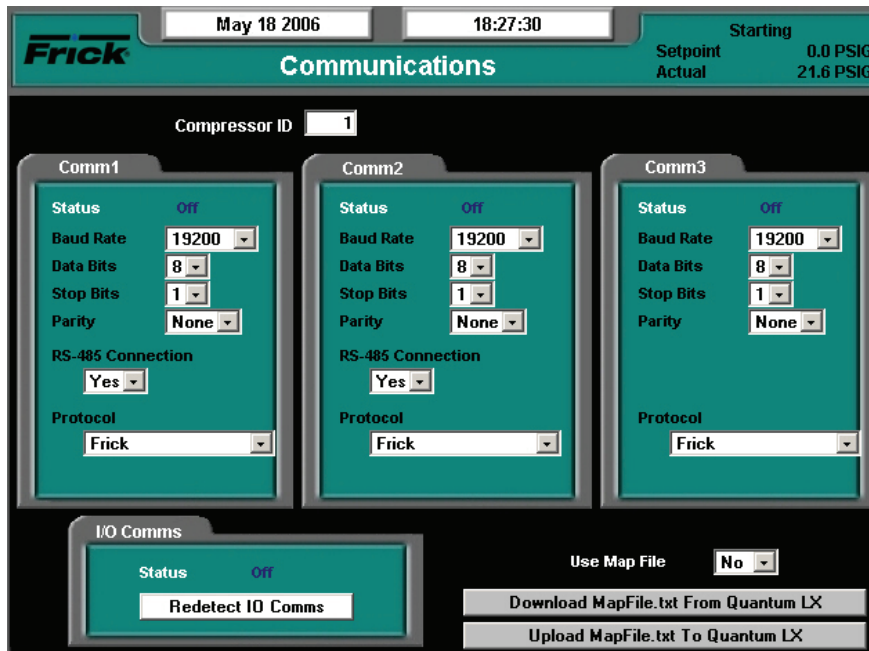

## PERFORMING THE COMMUNICATIONS LOOPBACK TEST

**Note:** Session must be set to at least user level 2 to access this feature.

Upon properly setting up the *Communications* screen, press the [Submit Changes] key. Access the *Communications Loop Back Test Screen* by pressing the [Menu] key, then the [Service...] key, and finally the [Communications Loop Back Test] key

Three buttons appear on this screen:

- Test Comm 1 – Comm 2
- Test Comm 1 – Comm 3
- Test Comm 2 – Comm 3

Ensure that the proper test harness is installed and the associated jumpers are in their correct positions for the particular test to be performed.

Pressing the appropriate test key will initiate the test. A dialog box will appear with one of the following messages:

**Testing** - This will appear as the test is running. NOTE: The test occurs so quickly that it may be possible that the word *Testing* will not appear if the test passes.

**Passed** - If the test passes, the word *Passed* will appear.

**Failed** - If the test does not pass, this will appear.

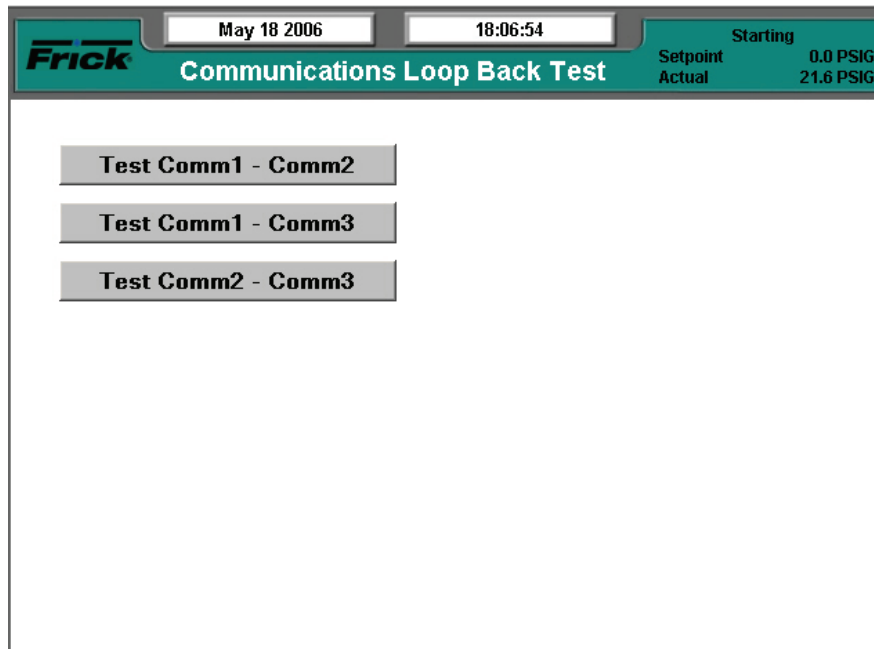

## APPENDIX A

### FRICK® SERIAL COMMUNICATIONS CONVERTER MODULE (Part Number 639B0086H01)

#### DESCRIPTION

Frick® Controls has developed a DIN-rail mountable communications module for the purpose of converting typical RS-232 serial protocol to either RS-422 or RS-485 serial protocols. The module will also work converting RS-422 or RS-485 to RS-232 (bi-directional). Due to the tight mounting restrictions in many existing control panels, this module provides the ultimate solution for field communications upgrades or modifications. No drilling is required, and minimal space is lost. The only requirement is an external source of 24 volt DC power.

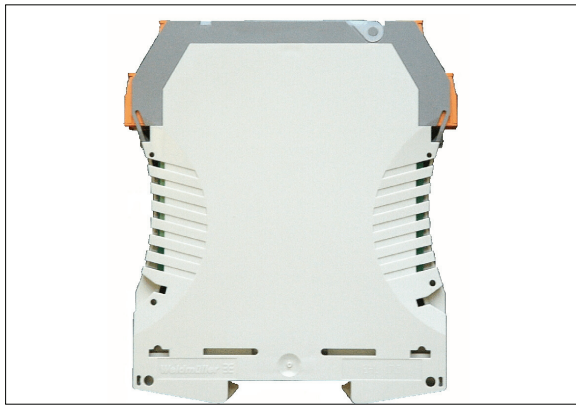

Frick® Communications Converter Module

#### SETTING THE DIPSWITCH

Inside the module is a circuit board which contains a DIP switch. This switch must be set according to the necessary protocol parameters that you are trying to achieve. It is recommended to set or verify the settings of this DIP switch before mounting and wiring the module. The circuit board must be removed from its housing in order to access this DIP switch. Each end of the housing has a small tab, located just below the bottom most terminal block of each end. Hold the module as shown in the following pictorial:

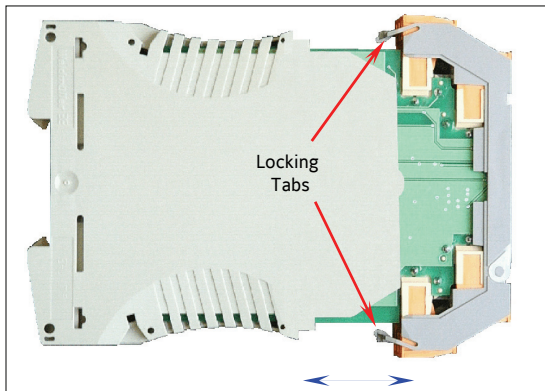

Disassembling the module

Press the tabs using the thumb and finger, and with your other hand carefully slide the circuit board out of the housing. Ensure that proper anti-static guidelines are followed while handling the circuit board.

The following diagram shows the circuit board:

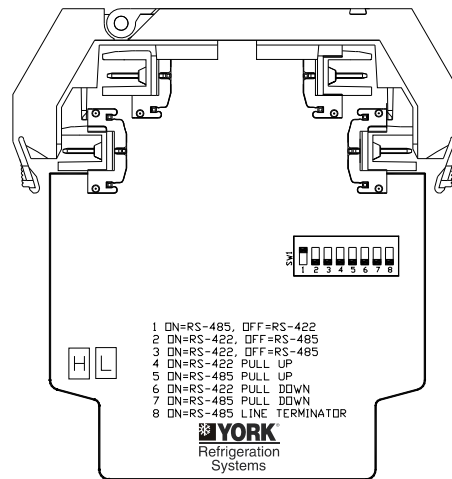

Module circuit board

For easy reference, the DIP switch position functions are provided on the board. For the purpose of clarity however, refer to the following table:

#### MODULE DIP SWITCH SETTINGS

Switch Position	ON Function	OFF Function
1	RS-485	RS-422
2	RS-422	RS-485
3	RS-422	RS-485
4	RS-422 Pull up	No pull up
5	RS-485 Pull up	No pull up
6	RS-422 Pull down	No pull down
7	RS-485 Pull down	No pull down
8	RS-485 line termination	No line termination

#### MOUNTING THE MODULE

This module can be mounted on the standard din rail that is available in most control panels.

- Find an open area of the din rail (5/8 inch minimum, for the width of the module), and preferably as far away from any inductive loads (relays, contactors, etc.) as possible.
- Module orientation is not critical, however, try to mount it so that all wiring connections can be made neatly, and according to any applicable local codes.
- Catch one end of the DIN rail latch (at the bottom of the module, under one edge of

the DIN rail, then snap the other latch onto the opposite side of the DIN rail, as shown below:

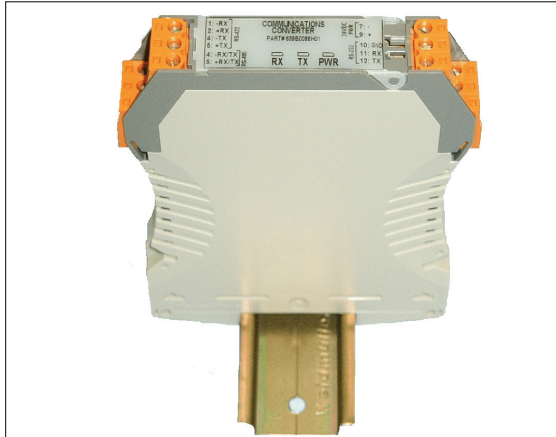

Module mounted to DIN rail

**WIRING THE MODULE**

There are twelve total wire terminal points on this module. Refer to the following table for the pin-out:

Wire terminal connections

Terminal Position	Module Power	RS-232	RS-422	RS-485
1			-RX	
2			+RX	
3 (Not Used)				
4			-TX	-RX/-TX
5			+TX	+RX/+TX
6 (Not Used)				
7	-24 VDC			
8 (Not Used)				
9	+24 VDC			
10		GND		
11		TX		
12		RX		

- Locate a suitable source for the +24 volt DC power. Using a minimum of 18 AWG stranded wire, connect the MINUS wire to terminal # 7. Connect the PLUS wire to terminal # 8.
- All remaining connections will be based upon the particular protocols that you have decided to use. Simply match the SIGNAL NAME from the source device to match the SIGNAL NAME of the module. All external communications wiring must conform with the Frick® *Proper Installation of Electronic Equipment in an Industrial Environment* publication.

**RS-232 CONNECTIONS**

Refer to the following figure for the pin connections showing how to wire a standard 9-Pin RS-232 connector directly to the Frick® Communications Converter Module:

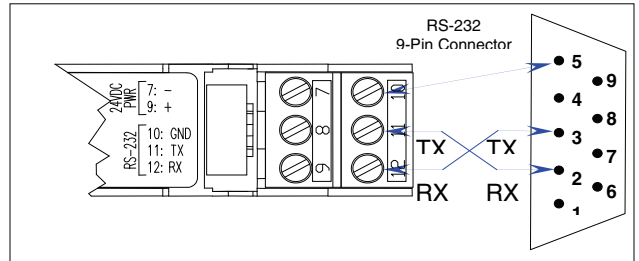

RS-232 Connections

Refer to the following figure for the pin connections showing how to wire the Converter Module (converts from RS-232 to RS-422/485) to the 10-pin Com-3 (PL6) connector on the Quantum™:

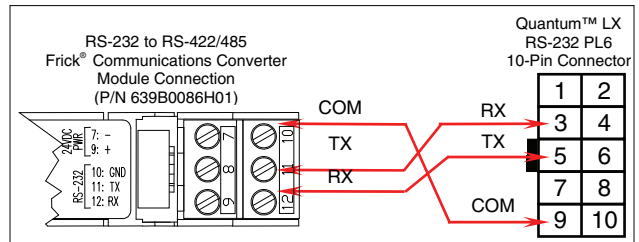

Com-3 (PL6) RS-232 Wiring To Frick® Communications Converter Module

**RS-422 CONNECTIONS**

Refer to the following figure for the pin connections showing how to attach a 4-wire RS-422 cable directly to the Frick® Communications Converter Module:

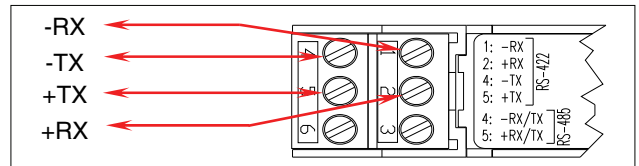

RS-422 Connections

**RS-485 CONNECTIONS**

Although typical RS-485 communications requires a control signal to change the state of the RX/TX driver lines to establish handshaking, this board incorporates a smart feature that handles this handshaking internally, without the user needing to provide it. It is a true two-wire system. Refer to following figure for the pin connections showing how to attach a 2-wire RS-485 cable directly to the Frick® Communications Converter Module:

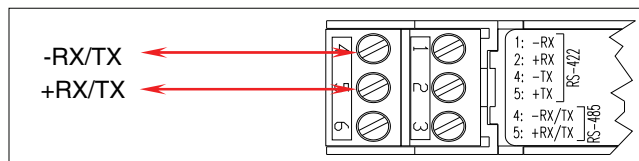

RS-485 Connections

APPENDIX B

QUANTUM™ LX ETHERNET COMMUNICATIONS WIRING

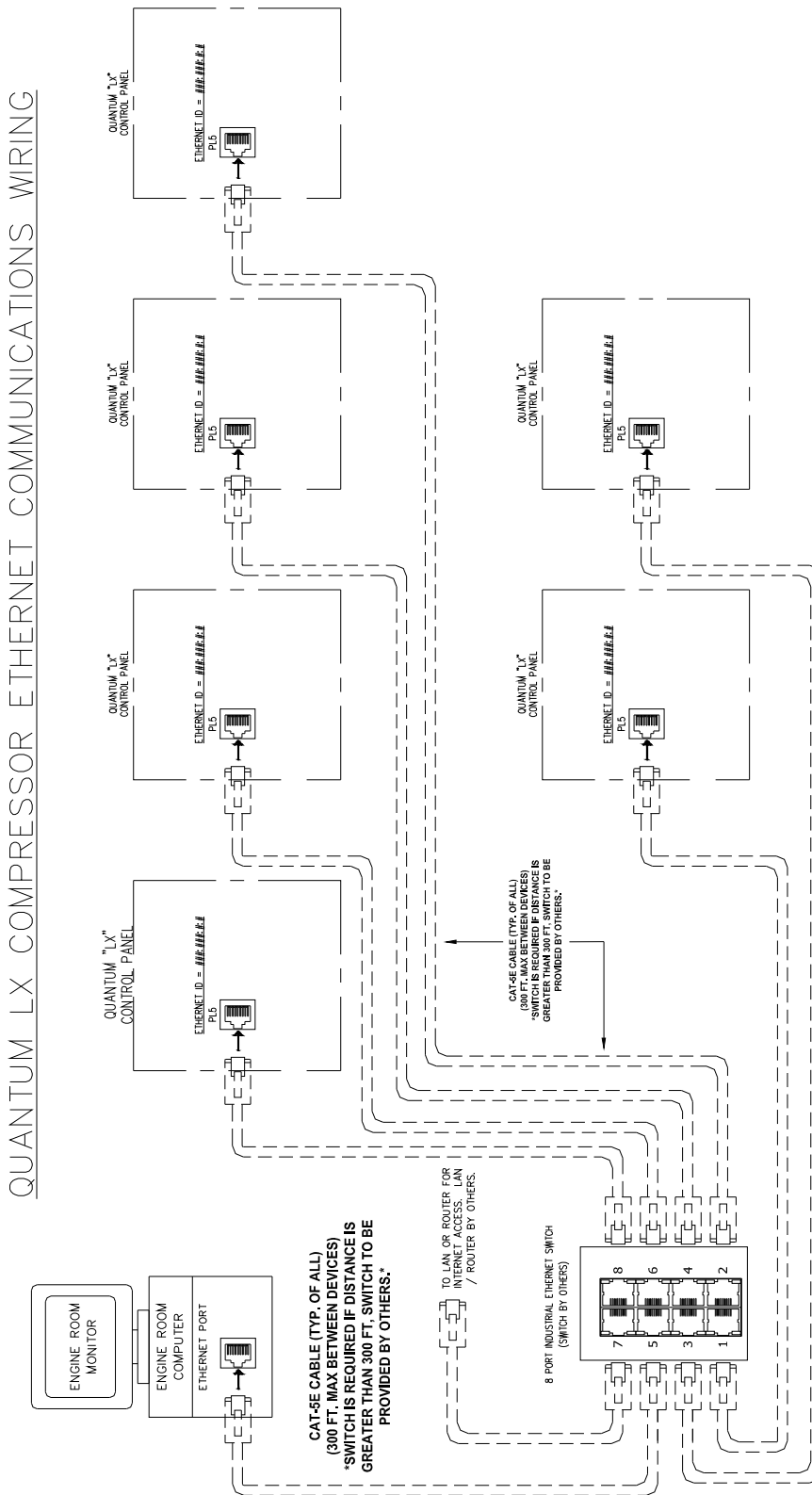

CAT-5E CABLE (TYP. OF ALL) (300 FT. MAX BETWEEN DEVICES)  
\*SWITCH IS REQUIRED IF DISTANCE IS GREATER THAN 300 FT. SWITCH TO BE PROVIDED BY OTHERS.\*

### APPENDIX C

### QUANTUM™ LX LOCAL ETHERNET CONFIGURATIONS

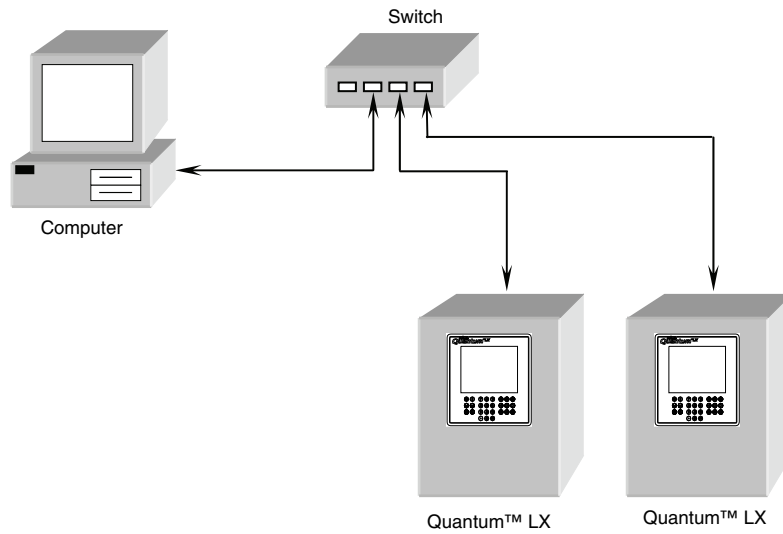

**Typical Small Local Quantum™ LX Ethernet Configuration**

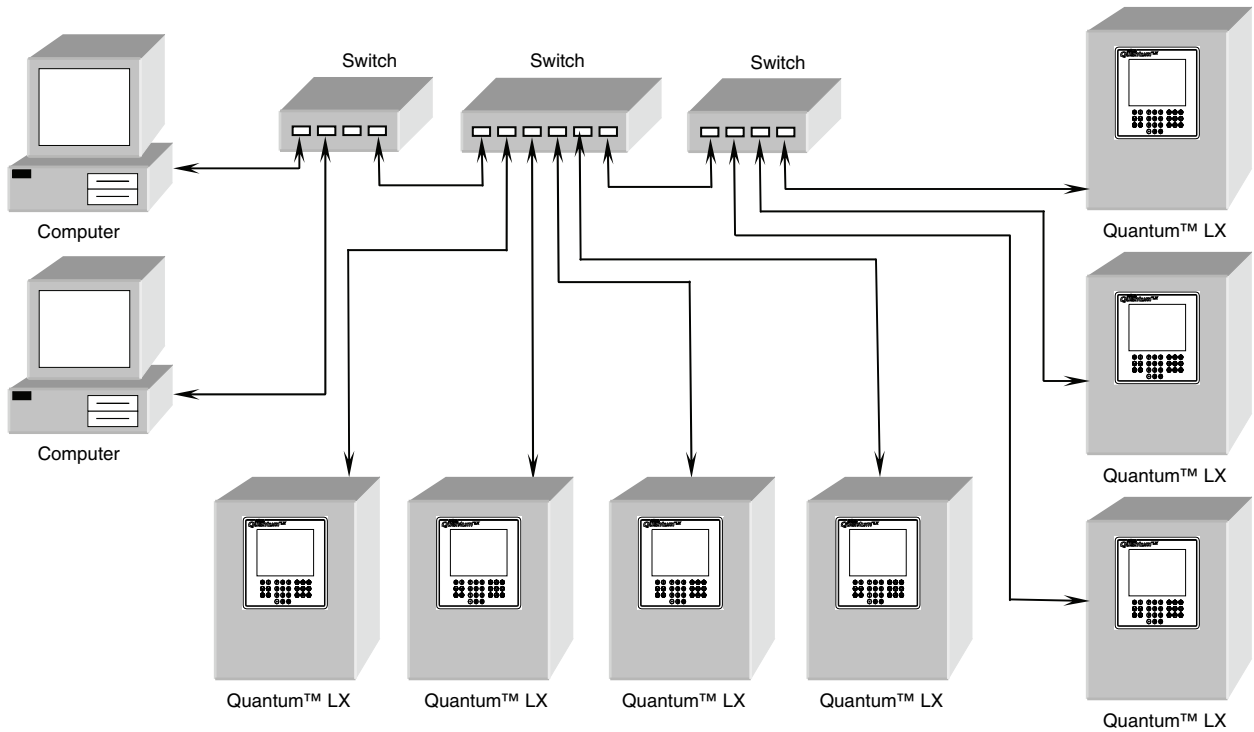

**Typical Large Local Quantum™ LX Ethernet Configuration**

### APPENDIX D

### QUANTUM™ LX ETHERNET NETWORK CONFIGURATIONS

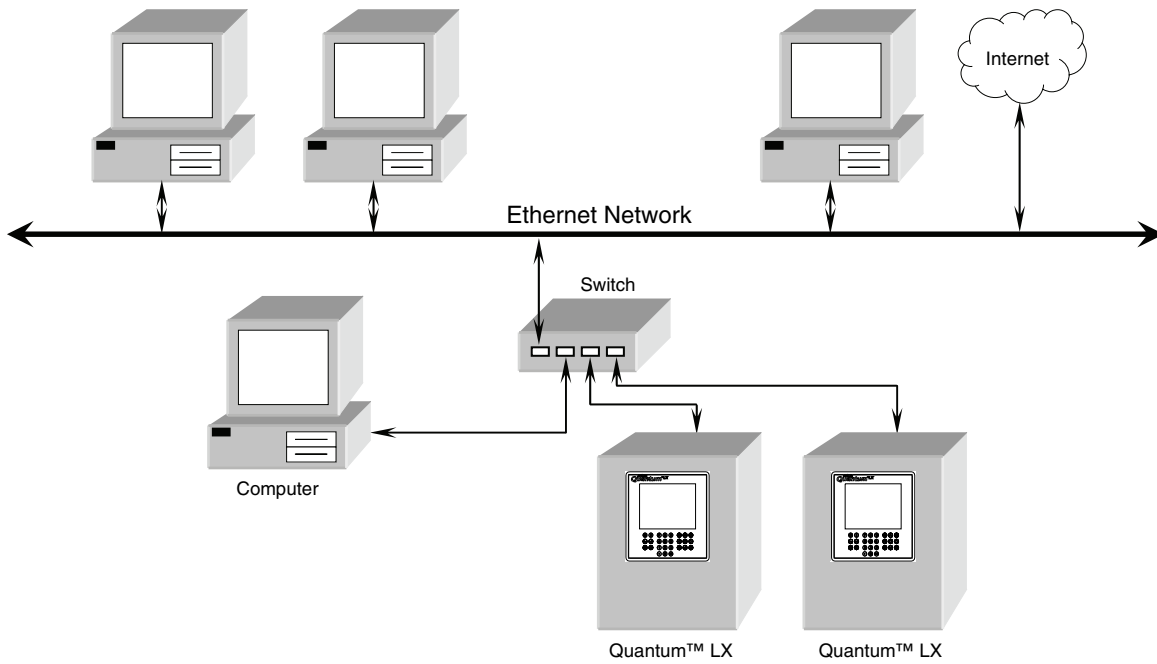

Typical Small Quantum™ LX Ethernet Network Configuration

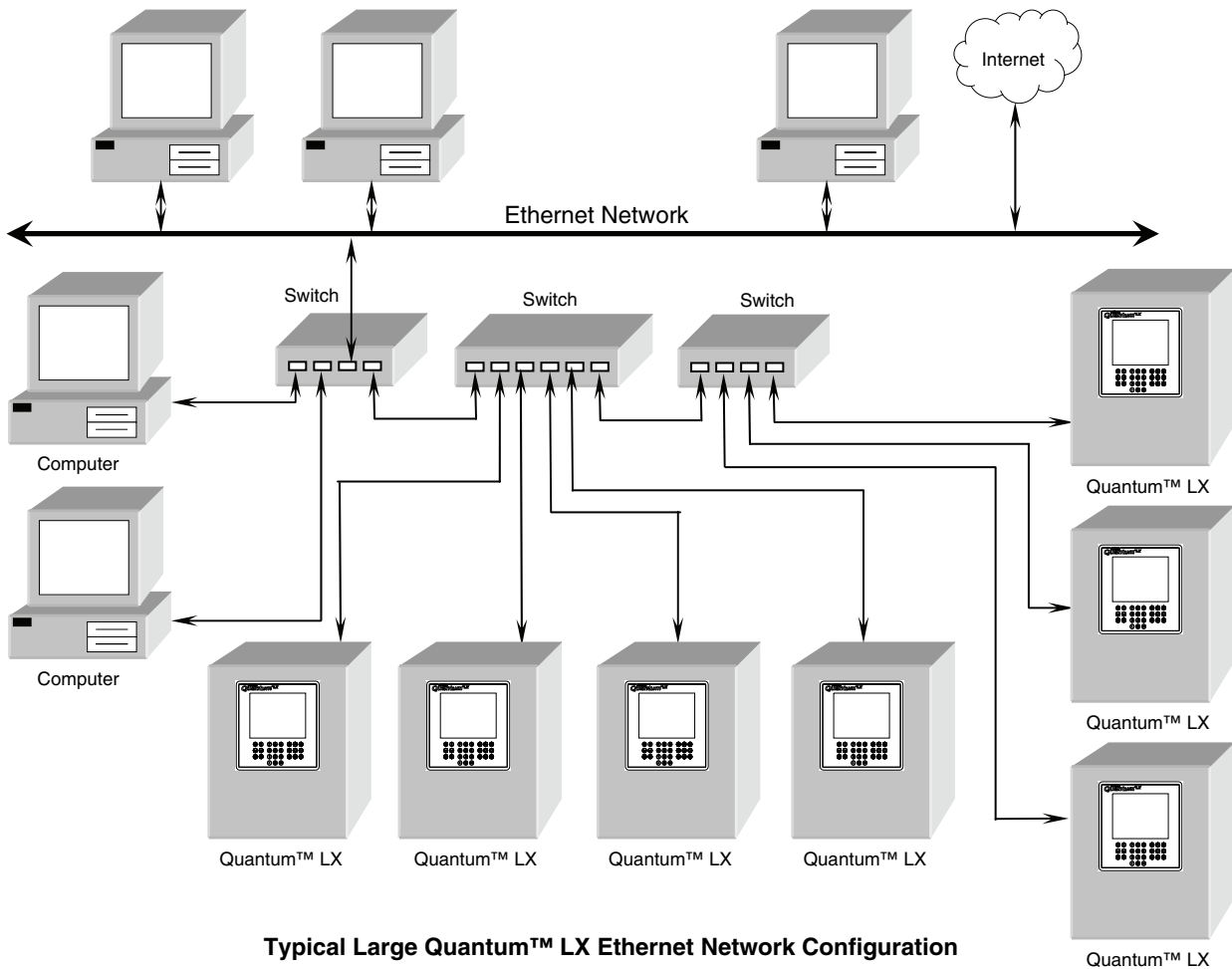

Typical Large Quantum™ LX Ethernet Network Configuration

APPENDIX E

QUANTUM™ LX SERIAL COMMUNICATIONS WIRING

COMPRESSOR QUANTUM COMMUNICATION WIRING

RECOMMENDED RS-485 CABLES		
MANUFACTURER	CABLE NUMBER	COLOR CODES
BELDEN	9841	TX+/RX+ WHT TX-/RX- BLK

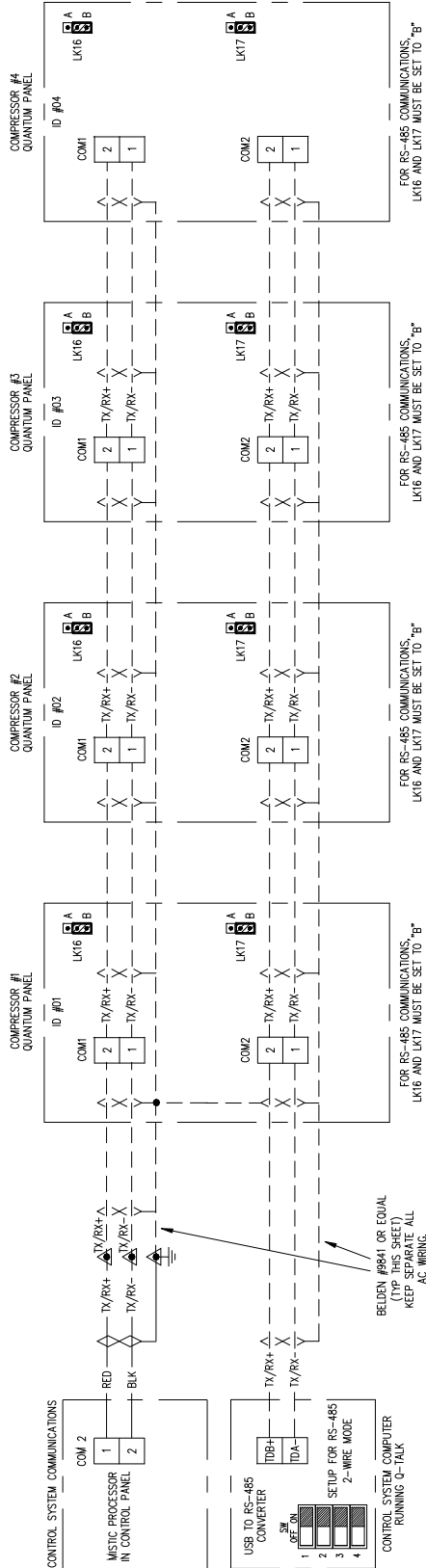

### SERIAL CONNECTIONS PICTORIAL

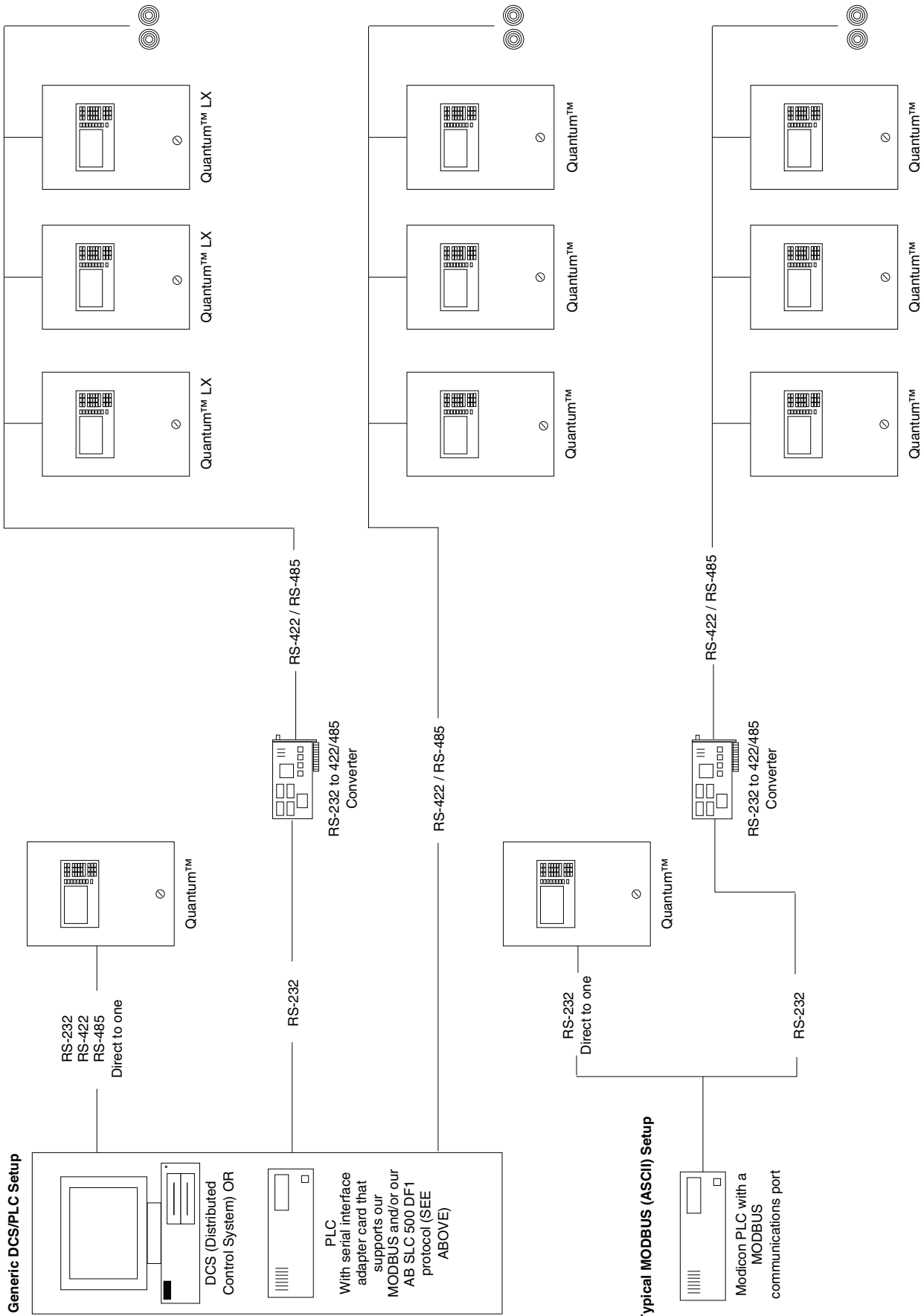

**SERIAL CONNECTIONS PICTORIAL (Continued)**

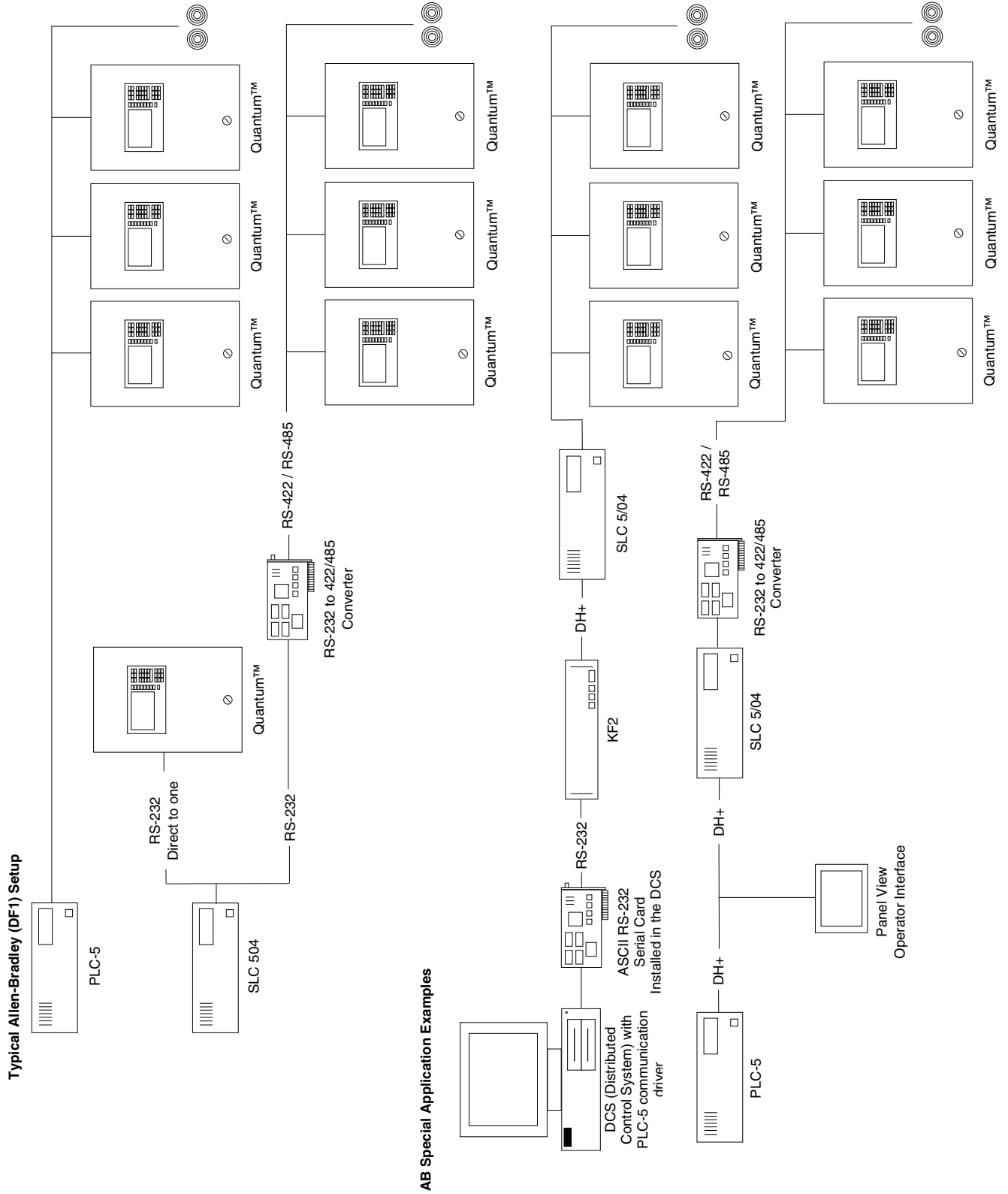

## SERIAL COMMUNICATIONS WIRING DIAGRAMS

### TO CUSTOMER REMOTE COMPUTER/DCS RS-485 COMMUNICATIONS

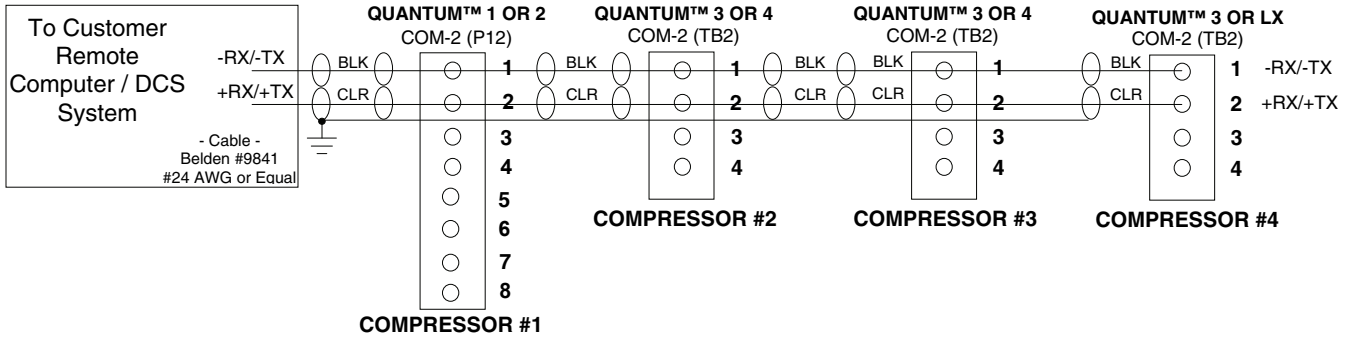

### TO CUSTOMER REMOTE COMPUTER/DCS RS-422 COMMUNICATIONS

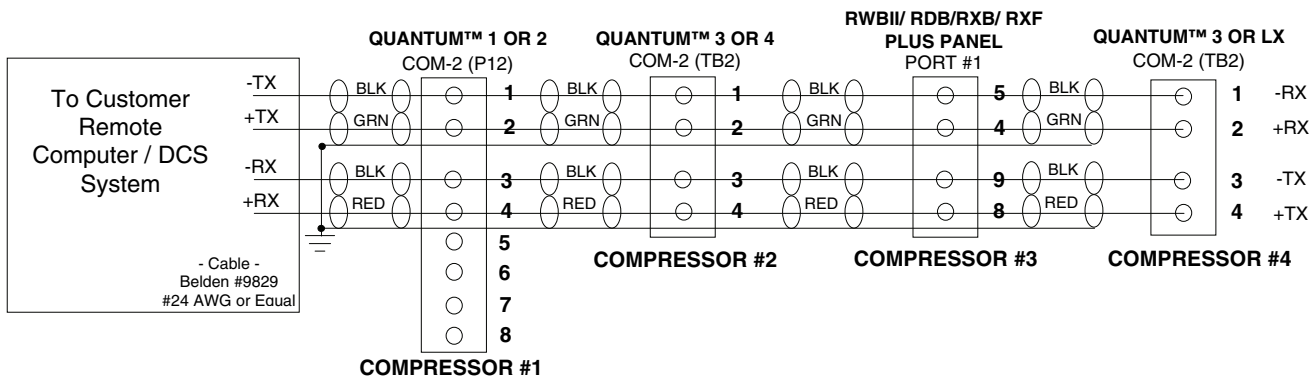

## INDEX

### A

Active .....	13, 14, 17
Address .....	60-115
Allen-Bradley .....	17, 33-35, 41
Allen-Bradley DF-1 .....	17
ASCII .....	16-18, 25, 34, 42-48, 50, 53, 55, 59

### B

Bandwidth .....	7
Baud Rate .....	13, 17, 33, 57
Bend Radius .....	6
Bits Per Second .....	53
Browser .....	6

### C

Cable Lengths .....	6
Cabling .....	52
Carriage Return .....	19, 20, 21, 24, 25, 28, 29
CAT 5 .....	6
CAT5 E .....	7
Character .....	28, 29
Checksum .....	17, 18, 25, 26
Com-1 .....	13, 53, 124, 125, 126
Com-2 .....	5, 11-13, 18, 52, 57, 124-127, 131
Com-3 .....	11-13, 124, 127, 135
Comm Port .....	17
Command .17-27, 29-34, 41-43, 45, 47, 49, 50, 52, 57	
Communications .....	129, 130
Communications WIRING .....	142
Compressor ID .....	13
Connections .....	140
CRC .....	33, 34, 44, 45, 49
Crossover Ccable .....	7

### D

Daisy-chaining .....	6
Data Bits .....	14, 17, 53
Data Packet .....	7, 25, 43
Data Table .....	60
DBS Motor Starter .....	16
DCS .....	33, 42, 142
Decimal .....	59, 109
Destination .....	7, 9
DHCP .....	9
Direct Connection .....	52

### E

E-mail .....	9, 10
EMI .....	7
Ethernet .....	6, 7, 8

### F

Failed .....	13, 14
Fixed .....	9, 91
Flash memory .....	33
Flow Control .....	53
Frick “#” Protocol .....	53
Full Duplex .....	12, 16, 17, 33
Function Code .....	43

### G

Gateway .....	9
---------------	---

### H

Half Duplex .....	12, 16, 17
Hexadecimal .....	59
HMI .....	52
Homerun .....	6
Hub .....	6, 7
Human Machine Interface .....	52
HyperTerminal ....	17, 25, 45, 47, 48, 49, 50, 52, 57, 58

### I

I/O Comms .....	14
ID .....	9, 16-34, 38, 41-43, 46, 47, 57, 104-107
ID code .....	29, 30, 31, 32
Internet .....	6, 8, 9
Internet Protocol .....	6
Internet Service Provider .....	6
IP. ....	6, 9, 10
ISP .....	6

### J

Jumper Settings .....	52
-----------------------	----

### L

Linefeed .....	25
Linux .....	6
LRC .....	44

### M

MAP .....	14
Map File .....	14
Master .....	33, 34, 42, 43, 45, 48, 49, 57
Message .....	10, 17, 33, 36, 37, 39, 43-49, 57
Microprocessor .....	18, 122
Modbus .....	16, 17, 42-47, 50, 53, 55, 60-115
Modem .....	6, 52
Multi-Drop .....	33, 42

### N

Network .....	6, 7, 8, 9, 10, 44, 46, 47, 52
---------------	--------------------------------

Network Switches ..... 7  
Noise Immunity..... 6

**O**

Oil Pressure ..... 120, 121  
Oil Temperature .....120

**P**

Packet .....57  
Panel 7, 9, 17, 18, 25, 33, 35-37, 39, 41, 43, 49, 50, 52  
Panel Setup ..... 52, 57  
Parity ..... 14, 17, 53  
PL6 ..... 11, 12, 13, 124, 127, 135  
PLC ..... 33, 42, 52, 76, 78, 79  
PLC5 ..... 33, 35  
Polled .....33  
Polling ..... 34  
Port .....29  
Programmable Logic Controller .....52  
Protocol.. 6, 9, 10, 14, 16-18, 25, 33-35, 50, 52, 53, 57

**Q**

Quantum™ .. 4-9, 11, 17, 18, 25, 26, 33-39, 41-50, 52,  
53, 56-58, 122-127, 135  
Quantum™ 1 & 2 ..... 122  
Quantum™ 3 ..... 57, 122  
Quantum™ 4 ..... 5, 57, 122, 123, 142  
Quantum™ ID .....57  
Quantum™ LX .....6, 7, 13, 25, 129, 130  
Query ..... 17, 25, 43

**R**

Read .....36  
Read Data.....17, 37, 42, 43  
Receiver .....17  
Redetect IO Comms..... 14  
Remote..... 19, 20, 25-27, 31, 33, 34, 41, 50, 52, 109  
Request ..... 57, 122  
Response..... 17, 25, 26, 31, 43, 48, 49, 54, 57  
RJ-45.....6, 7, 8  
Router ..... 9  
RS-232... 5, 6, 11, 12, 17, 38, 42, 58, 122, 124-127, 135  
RS-422 ..... 5, 11, 12, 17, 18, 42, 58, 122, 124-128, 131,  
135, 142  
RS-485 .....5, 11, 12, 17, 42, 58, 122, 124-128, 142  
RS-485/422.....125, 126

RSLogix5.....33, 35  
RTU..... 16, 17, 42, 43, 44, 45, 47, 49, 50  
RX2..... 17, 57

**S**

Screen ..... 14  
Sequencing ..... 125, 126  
Serial ..... 109  
Setting Up Hyperterminal.....52, 58  
Shielded..... 6, 8  
Shutdown10, 19, 22-24, 61, 68, 71, 79-84, 87-90, 92-  
97, 100  
Slave.....33, 34, 42, 104, 106, 108  
SLC ..... 33, 34, 38, 41  
SLC500 .....33, 34, 35, 38, 41  
SMTP ..... 10  
Source ..... 7  
Splice..... 7  
Star..... 6  
Status .....13, 57  
Stop Bits ..... 14, 17, 53  
STP ..... 8  
Subject ..... 10  
Subnet Mask ..... 9  
Switch..... 6, 7, 122

**T**

TCP/IP ..... 9  
Temperature .....121  
Testing Communications.....56, 57  
Timeouts..... 33  
TONING..... 7  
Troubleshooting..... 17, 127  
TX2..... 17, 57

**U**

Unshielded ..... 6  
USB..... 6, 14, 15  
UTP..... 8

**W**

Warning..... 10, 61, 68, 80-84, 87-90, 92-97, 100  
Web..... 6, 9  
Web Server Port..... 9  
Windows..... 6, 17, 25, 45, 47, 49, 52