



Form S90-562 O (MARCH 2008)

**OPERATION - SERVICE**

File: SERVICE MANUAL - SECTION 90  
Replaces: NOTHING  
Dist: 3, 3a, 3b, 3c

**OPERATION – SERVICE**  
(SESSION LEVEL 2)

**FRICK QUANTUM™ LX**  
**CONDENSER/VESSEL**  
**CONTROL PANEL**  
VERSION 3.0x

Please check [www.frickcold.com](http://www.frickcold.com) for the latest version of this publication.

## Table of Contents

<b>TYPICAL SYSTEM CONFIGURATION .....</b>	<b>4</b>
<b>OVERVIEW OF OPERATOR INTERFACES .....</b>	<b>5</b>
Quantum™ LX Control Panel .....	5
Computer Web Browser.....	5
<b>OPERATOR ACCESS .....</b>	<b>6</b>
To Change Setpoints .....	6
Common Terminology.....	6
Keys and Key Functions .....	6
<b>MENU STRUCTURE .....</b>	<b>8</b>
<b>GRAPHIC SCREENS.....</b>	<b>9</b>
OPERATING STATUS (HOME) .....	9
USER DEFINED	
Condenser or Vessel.....	10
STATUS	
Condenser Status .....	11
Vessel (1, 2, 3) Status.....	12
Trending	
Setup.....	13
Real Time Trending.....	14
History Trending.....	15
Real Time Data Log .....	16
History Data Log .....	17
Event Log.....	12
SAFETIES	
Current Safeties .....	17
Safety History.....	20
SETPOINTS	
Condenser Step Control.....	21
Condenser Summer Sequence.....	23
Condenser Winter Sequence .....	23
Condenser Variable Speed Fan.....	24
Condenser Control Overrides .....	25
Vessel 1 Level Control .....	26
Vessel 1 Pump Control .....	27
Vessel Safeties .....	28
PID Setup	
Condenser.....	29
PID Setup - Vessel.....	30
Overview to Tuning a PID Controller.....	31
Auxiliaries	
Analog Inputs – Condenser (or Vessel) Safeties .....	32
Digital Input Configuration (Condenser or Vessel).....	33
Digital Output Configuration - Condenser .....	34
Digital Output Configuration - Vessel .....	35
Panel.....	36
CALIBRATION	
Vessel 1-3.....	38
Analog Outputs – Condenser Outputs .....	39
Condenser (or Vessel) Auxiliaries – Page 1 .....	41

Condenser (or Vessel) Auxiliaries – Page 2.....	42
CONFIGURATION	
Panel Configuration.....	43
Condenser Step Configuration.....	44
Communications.....	45
Ethernet.....	47
Security.....	48
SESSION.....	49
SERVICE	
Digital.....	50
Analog.....	50
Communications Log.....	51
Communications Loop Back Test.....	52
Diagnostics.....	52
Software Maintenance.....	53
ABOUT.....	55
MISCELLENEOUS SCREENS - Apha.....	56
<b>Alarms/Shutdowns Messages.....</b>	<b>57</b>
<b>Index.....</b>	<b>59</b>

### Warning

The Quantum™ LX Control has the capability of being modified by the user/owner in order to obtain different performance characteristics. Any modification to the standard default settings may have a severe negative impact on the operation and performance of the equipment. Any modification to these control settings is the sole responsibility of the user/owner and Frick disclaims any liability for the consequences of these modifications. It is possible that the modification of these settings may cause improper operation and performance that results in property damage, personal injury or death. It is the responsibility of the user/owner to evaluate and assess the consequences of their actions prior to modifying the controls for this unit.

## TYPICAL SYSTEM CONFIGURATION

A typical Condenser/Vessel system may involve as little as a single Condenser, or a single Vessel. Each unit within the Condenser/Vessel system operates independently of one another yet they may all be inter-connected via a common Ethernet connection. The four major parts of a system may include the Condenser or Vessel Panel, the Quantum™ LX Panel, an optional Ethernet Hub or Switch, and an optional computer with Web Browser (or an optional Operator Interface Panel).

all of the “straight through” or pin-to-pin variety. NOTE: If you are communicating directly to a single Quantum™ LX panel only, you may use the setup which is shown on the next page.

- **Computer With Web browser (or HMI/Operator Interface)** – This is an optional feature. It provides overall system integration between all of the connected sub-systems. Any of the attached Quantum™ LX panels can be accessed independently. Setpoints can be adjusted, and overall system performance can be monitored.
- **Ethernet Hub (or Switch)** – Also optional, to be used only when using a Computer with web browser, or the HMI Operator Interface. Allows multiple Quantum™ LX panels to be connected. The Ethernet cables used in this configuration are
- **Quantum™ LX Panel** – Provides software and communications control to each of the connected Condenser or Vessel Panels. Can connect to a Computer via an Ethernet Hub or Switch.
- **Condenser/Vessel Panel** - Each Condenser or Vessel panel provides the actual digital and analog control for its attached devices. These panels communicate data via RS-485 back to their associated Quantum™ LX panels

Refer to the following pictorial:

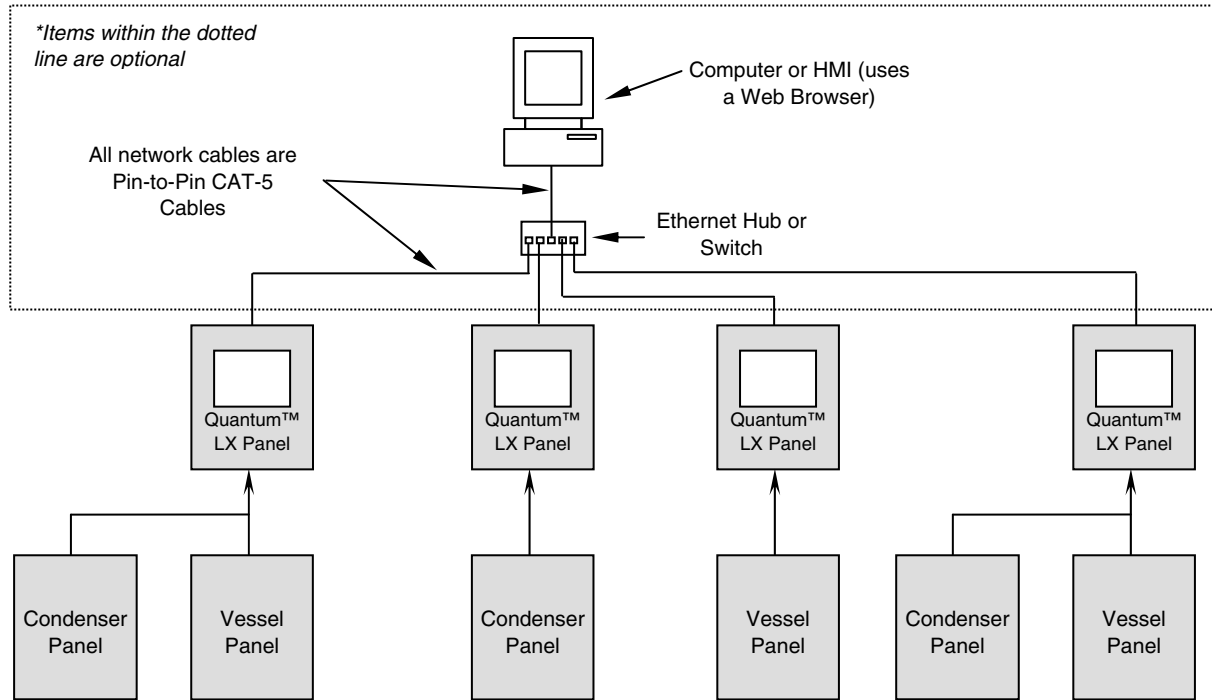

## OVERVIEW OF OPERATOR INTERFACES

### Quantum™ LX Control Panel

The Condenser/Vessel system is controlled by a computer based machine control system. The controller continuously monitors the conditions and operation of any Condenser or Vessel panels that it is directly connected to. It also directs the operation of components.

The panel user interface is designed to allow an operator to efficiently access and control the operation of all connected panels and subsystems. The control panel screen is used to display graphic screens. By pressing a key on the keypad, the labeled or described function is recognized by the control processor.

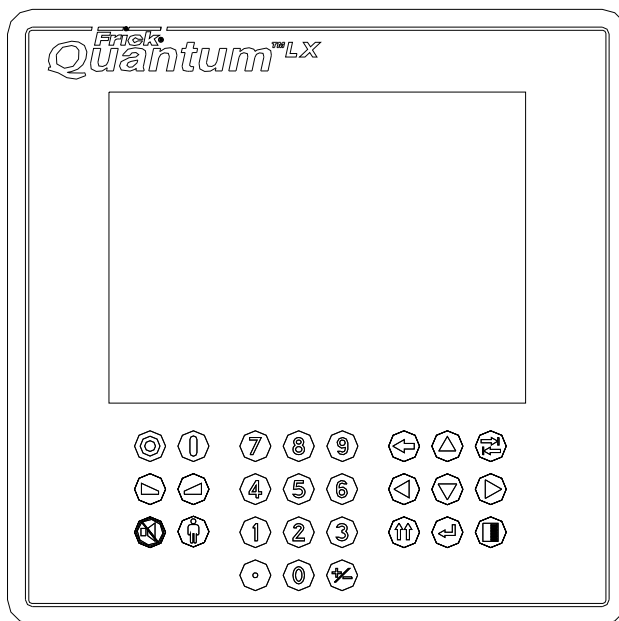

The graphic screens that are displayed are composed in HTML (Hypertext Markup Language), to make them compatible with most web browsers, in this way, any number of Quantum™ LX Panels can be interconnected and monitored from a laptop or desktop computer.

### Computer Web Browser

The web browser interface can be viewed from any desktop or laptop computer, which has access to the network that a Quantum™ Panel is attached to. To change screens, setpoints, etc., you simply use a mouse and the keyboard to view and change data.

All screens that are shown will have several buttons on the right hand side of the screen. Most screens will have three buttons, and one setpoint box. The three buttons are:

**[Menu]** – Clicking on this button will cause the main menu to appear on the left side of the screen. Clicking a second time will cause the menu to disappear.

**[Start Refresh] [Stop Refresh]** – This button(s) appears immediately below the **[Menu]** button. This is actually a toggle button, as it changes function from Start Refresh to Stop Refresh each time it is clicked on. When the button shows as Start Refresh, a setpoint box will appear below it, with a time value displayed. The time value determines how often the display screen will refresh, or update its values. This time value is defaulted to 5 seconds, which means that the display will update all values shown every 5 seconds. Depending on the network connection speed, this updating may interfere with your ability to change data setpoints, because the screen will refresh while you are entering the data. To solve this, simply increase the refresh time. The other alternative is to toggle the Refresh Button. By pressing **[Stop Refresh]**, screen refreshing will terminate, and the time setpoint box will reappear. In this state, the particular screen that you are viewing will never update the displayed values. Changing to another screen will show the most recent values on the new screen, and then will not update again. So in the Stop Refresh state, screens will only be updated when new screens are accessed. This feature should not be used when monitoring for data. Try to find an acceptable refresh time for the Start Refresh state.

One screen that DOES NOT have these buttons is:

**Software Maintenance** – To leave this screen, click on **[Exit]** button. **Note:** Using the **[Exit]** button takes several seconds, and it will force the password level back to zero.

There are numerous screens that have additional buttons to those mentioned here. These additional buttons are self-intuitive, and as such, are not discussed here.

---

## OPERATOR ACCESS

---

Operator access to this system (either through the Quantum™ LX panel, or a web browser) is through various screens. A screen is the physical representation of data on the display. Icons have been used to help an operator quickly identify functions. An icon is a small graphic symbol representation. Each screen has a title area. The title is descriptive of the screen. The current date and time is shown in this title area. The day of the week, Sunday (Sun.) through Saturday (Sat.) is displayed. The month of the year from January (Jan.) to December (Dec.) is displayed. The day of the month from 1 to 31 and the year from 0001 to 9999 is displayed. The time displayed is the current time in 24 hours (military) format. The hours, minutes and seconds are displayed.

Some screens are for informational purposes only, and cannot be modified. These screens typically show analog values such as temperature and humidity, which are strictly functions of an associated sensor, and as such, cannot be modified. Other screens show setpoint values that allow the operator to change, in order modify the units operating characteristics. For easier viewing, related information is separated into boxes. To further assist the operator, an on-line help is provided. Sometimes selections appear differently (a box may be dimmed) to indicate that the feature is unavailable.

### To Change Setpoints

The setpoints define the operation and limits of each Condenser or Vessel panel. Adjustable setpoints are setpoints that an operator can easily change in the field. These setpoints are stored in EPROM (non-volatile memory).

**NOTE:** Adjustable Setpoints are not lost after power is interrupted. However, we suggest that a list of Adjustable Setpoints be recorded and stored safely to facilitate reentry, in case there is a need to return to the original settings.

1. The data entry fields are identified by a black box with a white interior. The data is shown in black text. When on a screen that has adjustable setpoints, select the setpoint box that you wish to modify (either by touching that box if a touch-screen or selecting it with a mouse for a web browser). Once the data field has been selected, the background turns blue, and the text turns white.

2. The current value of that setpoint is shown. Use the keyboard to enter the new value. Typing a new value will completely erase the old value.
3. Press the keyboard **[ENTER]** key to input the new data in the data entry field and to move to the next data entry field.
4. If the data entered into the setpoint box is valid, then once you have pressed the keyboard **[ENTER]** key, the **[SUBMIT]** box in the lower left hand side of the viewing screen will turn from a grey background, to a red background. Press the **[SUBMIT]** button to load the changed setpoint to the controller.
5. If the value is out of bounds, an error message box displays the proper range of values. Press the **[OK]** button to acknowledge the error message. Re-enter the correct value.

When finished making any changes to the data on an adjustable setpoint display press the **[SUBMIT]** key to accept all changes.

### Common Terminology

**Shutdown** - A critical safety limit has been reached or exceeded and the associated unit has been shutdown.

**Warning** - A Warning setpoint has been reached or exceeded. The associated unit will continue to run if running.

**Manual** - The device is being controlled from direct commands or keys at the local controller.

**Auto (Automatic)** - The device is being controlled from setpoints at the local controller.

**Remote** - The device is being controlled by a remote controller.

## KEYS AND KEY FUNCTIONS

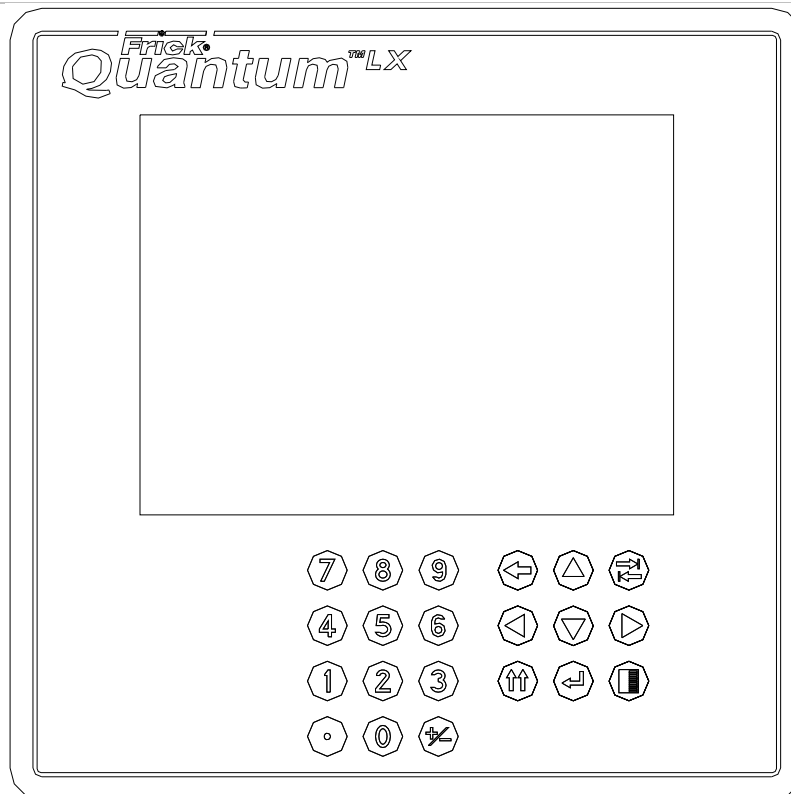

The following is a list of the labeled keypad keys and the actions that occur when they are pressed:

Key	Function
	<b>NUMERALS [0] - [9]</b> - The numerical keys are used to enter a value in a data field. These keys may also be used to enter text and special characters. Refer to the section entitled <i>MISCELLENEOUS Screens – Alpha</i> for additional information.
	<b>DECIMAL [.]</b> - This key is used when entering a decimal value in a data field. This key may also be used to enter special characters. Refer to the section entitled <i>MISCELLENEOUS Screens – Alpha</i> for additional information.
	<b>[+/-]</b> - When changing a value in a data field, this key toggles the value between negative and positive. This key may also be used to enter special characters. Refer to the section entitled <i>MISCELLENEOUS Screens – Alpha</i> for additional information.
	<b>[BACKSPACE]</b> - Pressing this key will cause the current location of the cursor to backup one position per key depression. When changing a value in a data field, this key will delete the selected character.

Key	Function
	<b>[UP ARROW]</b> - Provides upward navigation within the <i>MAIN MENU</i> window.
	<b>[TAB]</b> - When in the mode of changing setpoints, pressing this key will cause the cursor to jump to the next data entry field.
	<b>[LEFT ARROW]</b> - When in the mode of changing setpoints, this key is used to go to the previous data entry field. When the <i>MAIN MENU</i> is shown, pressing this key will cancel the window.
	<b>[DOWN ARROW]</b> - Provides downward navigation within the <i>MAIN MENU</i> window.
	<b>[RIGHT ARROW]</b> - When in the mode of changing a data entry field, this key is used to go to the next character.
	<b>[ENTER]</b> - When changing data in a data entry field, this key will accept the change. This key is also used to select items on Menu Windows.
	<b>[SUBMIT]</b> - After changing a setpoint value, Use this key to enter (submit) the change.
	<b>[MENU]</b> - Shows the <i>MAIN MENU</i> window. This window shows the main selections for accessing information, setup of options, and setpoint entry.

## MENU STRUCTURE

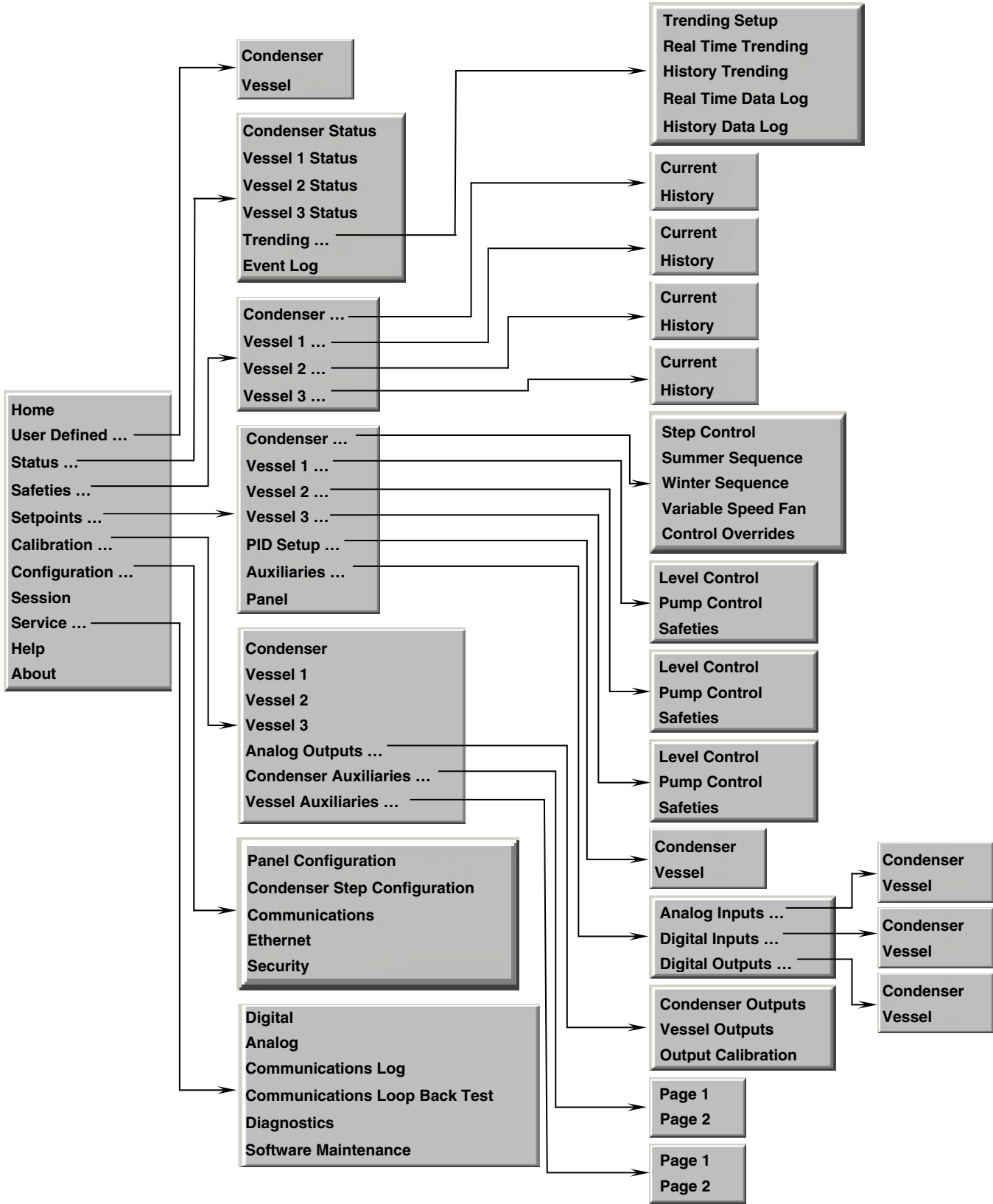

The above graphic represents the menu structure, or tree, of the Condenser/Vessel Quantum™ LX screens. Refer to this tree when accessing the various screens. Please note that this screen list is complete and that certain screens may not be available as shown here, depending upon the enabled options.

**GRAPHIC SCREENS**

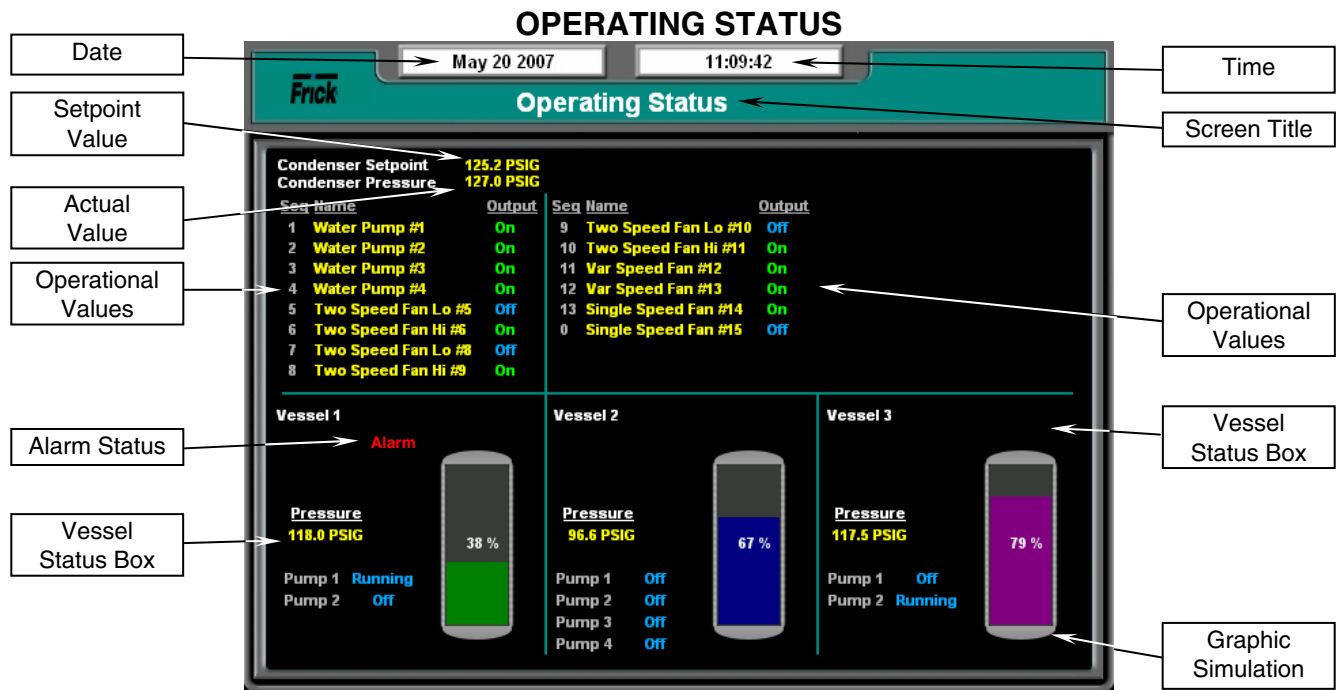

The most important information about the Condenser/Vessel package is displayed here:

**DATE** - The actual date will be displayed in this box. The date must first be set correctly on the **Configuration** screen. Once set, the date is automatically adjusted at the end of each month, much like the calendar feature of most modern watches. The primary use of the date feature is to provide a date stamp for Warnings and Shutdowns. Refer to the section entitled *Setting the Date and Time* for further information.

**TIME** - The actual time will be displayed in this box. The time must first be set correctly on the **Configuration** screen. The time will also need to be adjusted for those locations which observe Daylight Savings Time. The primary use of the time feature is to provide a time stamp for Warnings and Shutdowns. Refer to the section entitled *Setting the Date and Time* for further information.

**SCREEN TITLE** - This is the title for the screen that is showing. Each screen will have a title. The Quantum™ LX manuals will extensively refer to screens by these names. When referred to in these manuals, screen names will be shown in bold italic print, such as ***Operating Status***.

**SETPOINT VALUE** – This is the setpoint maintained by the control.

**ACTUAL VALUE** – The actual reading that was chosen as the control input.

**OPERATIONAL VALUES** – These values are set up on the *Condenser Step Configuration* screen:

**Seq** – This column shows which position in the Condenser sequence that the associated named control device will occur.

**Name** – Each of the lines within this column will contain the name of the sequence step.

**Output** – This line will show whether the output module for the associated device is on (energized) or off (de-energized).

The status of a condenser step's outputs are displayed as one of the following messages:

- **On** – The input or output is energized or turned on.
- **Off** – The input or output is de-energized or turned off.

**ALARM STATUS** - The alarm status of each vessel is shown in red letters within the applicable vessels status box. The status box is blank if there are no alarms present.

If a warning or shutdown condition exists, the name of the condition will be shown in red letters.

**VESSEL STATUS BOX** - Shows the present operating status of each of the configured Vessels (1-3). A pictorial graphic simulation is shown for each Vessel, which depicts the percentage of liquid it contains. The current pressure within each vessel is shown, as well as the alarm status and conditions of each of the configured pumps.

## USER DEFINED OPERATING STATUS SCREEN – Condenser or Vessel

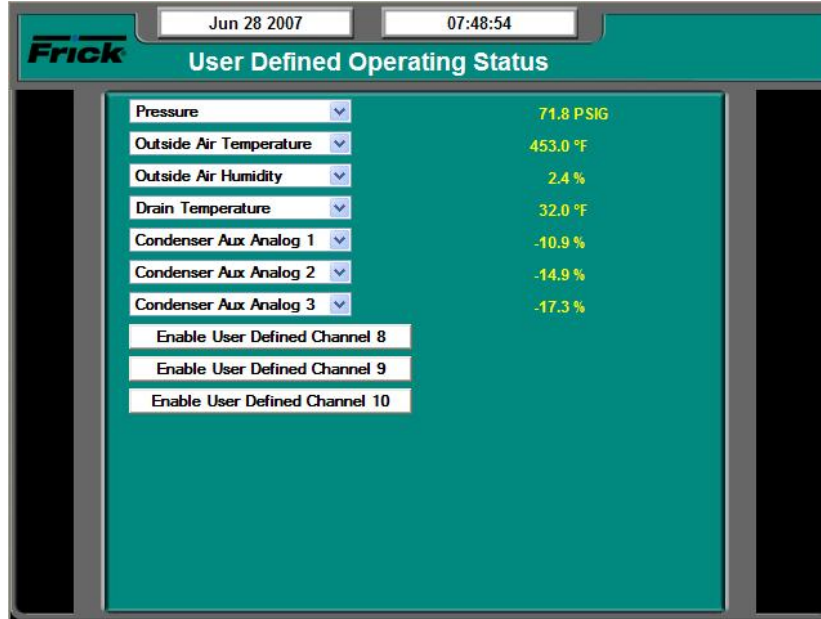

### ACCESSING:



User Defined...

Condenser or Vessel

**DESCRIPTION:** The purpose of this screen is to allow the user to assign additional analog channels to be more readily viewable. The screens are identical for both Condenser and Vessel, with the exception of the drop down selections, which are listed in the write up at the end of this page. Since the main Operating Status (Home) screen is capable of only showing a limited number of pre-assigned analog values, it may be desirable for the user to have a method of viewing additional information that they can select, on a common screen. They may even select values that are already being displayed on the Operating Status screen, as well as values that are not shown there. There is also a screen available to set the Vessel User Defined values.

This screen is provided to allow the user to view up to 10 different analog channels of their choosing.

As an example of how this screen works, assume that in addition to the data that is shown on the **Operating Status** screen, the user would like to monitor the *Pressure, Outside Air Temperature and Drain Temperature*, all on the same screen (this one). In order to set this screen up to show these three values, the user would highlight the Enable User Defined Channel 1 (or whatever channel they wish to use), by selecting it with the mouse. Once the box is highlighted, click on it to cause the possible settings for the channel to appear. Use the mouse to scroll through the list. When the selection that you want to use has been highlighted, click on it to select it. Once selected, a value will appear to the right of the list, which corresponds to the analog value for that channel.

The following selections may be shown on this screen:

#### For Condenser:

- Outside Air Temperature
- Pressure
- Outside Air Humidity

- Outside Air Humidity
- Drain Temperature
- Condenser Aux Analog 1 - 10
- None

#### For Vessel:

- Refrigerant Level – Vessel 1 – 3
- Vessel Pressure – Vessel 1 – 3
- Pump 1 Motor Amps – Vessel 1 - 3
- Pump 2 Motor Amps – Vessel 1 - 3
- Pump 3 Motor Amps – Vessel 1 – 3
- Pump 4 Motor Amps – Vessel 1 – 3
- Pump 1 High Side Pressure – Vessel 1 – 3
- Pump 2 High Side Pressure – Vessel 1 – 3
- Pump 3 High Side Pressure – Vessel 1 – 3
- Pump 4 High Side Pressure – Vessel 1 – 3
- Pump 1 Low Side Pressure – Vessel 1 – 3
- Pump 2 Low Side Pressure – Vessel 1 – 3
- Pump 3 Low Side Pressure – Vessel 1 – 3
- Pump 4 Low Side Pressure – Vessel 1 – 3
- Vessel Aux 1 – 10
- None

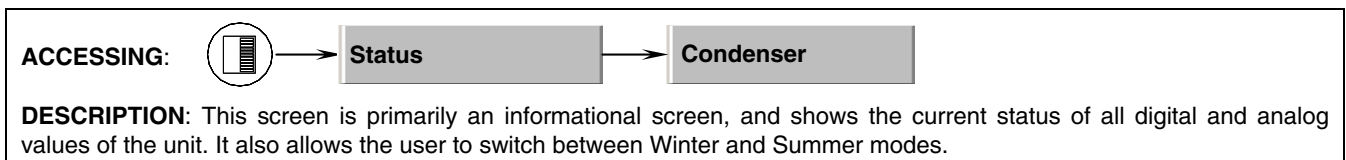
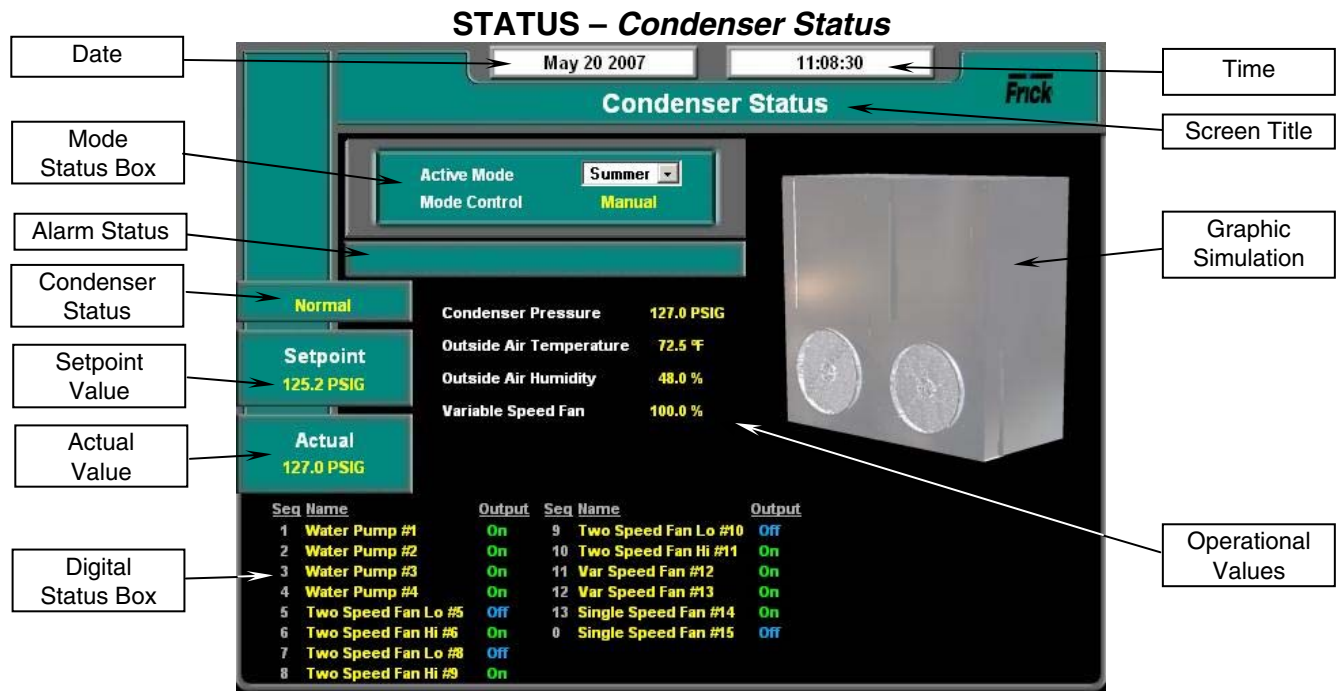

The most important information about the Condenser package is displayed here:

**DATE** - The actual date will be displayed in this box. The date must first be set correctly on the **Configuration** screen. Once set, the date is automatically adjusted at the end of each month, much like the calendar feature of most modern watches. The primary use of the date feature is to provide a date stamp for Warnings and Shutdowns. Refer to the section entitled *Setting the Date and Time* for further information.

**TIME** - The actual time will be displayed in this box. The time must first be set correctly on the **Configuration** screen. The time will also need to be adjusted for those locations which observe Daylight Savings Time. The primary use of the time feature is to provide a time stamp for Warnings and Shutdowns.

**SCREEN TITLE** - This is the title for the screen that is showing. Each screen will have a title. The Quantum™ LX manuals will extensively refer to screens by these names. When referred to in these manuals, screen names will be shown in bold italic print, such as **Operating Status**.

**MODE STATUS BOX** - There is a single drop down menu selection located here:

**Active Mode**

- **Summer** - The condenser is using the Summer setpoints for control.

- **Winter** - The condenser is using the Winter setpoints for control.

**SETPOINT VALUE** – This is the setpoint maintained by the control.

**ACTUAL VALUE** – The actual reading that was chosen as the control input.

**OPERATIONAL VALUES** – These values are set up on the *Condenser Step Configuration* screen:

- **Condenser Pressure**
- **Outside Air Temperature**
- **Outside Air Humidity**
- **Variable Speed Fan**

**DIGITAL STATUS BOX** - The status of a condenser step's outputs are displayed as one of the following messages:

- **On** – The input or output is energized.
- **Off** – The input or output is de-energized.

**ALARM STATUS** - If a warning or shutdown condition exists, the name of the condition will be shown in red letters. The status box is blank if there are no alarms present.

### STATUS – Vessel Status

The screenshot shows the 'Vessel 1 Status' screen. At the top, it displays the date 'May 20 2007' and time '11:07:37'. The main title is 'Vessel 1 Status'. Below this, there is a 'Pump Status Box' showing Pump 1 as 'Running' at 78.7 PSID and Pump 2 as 'Off' at 58.2 PSID. The 'Vessel Status' is 'Normal'. The 'Setpoint Value' is 50.0% and the 'Actual Value' is 38.7%. A 'Graphic Simulation' of the vessel is shown on the right. At the bottom, there is a 'Digital Status Box' with various indicators: Solenoid 1 (Open), Solenoid 2 (Closed), Operating Level 1 (Off), Operating Level 2 (On), High Level Shutdown (On), High Level Warning (On), Low Level Warning (On), and Low Level Shutdown (On). Callouts on the left identify: Date, Current Vessel Being Viewed, Mode Status Box, Alarm Status, Vessel Status, Setpoint Value, Actual Value, and Digital Status Box. Callouts on the right identify: Time, Screen Title, Graphic Simulation, and Operational Values.

**ACCESSING:** → **Status** → **Vessel 1**

**DESCRIPTION:** This screen is primarily an informational screen, and shows the current status of all digital and analog values of the unit. It also allows the user to switch between pumps, and to turn the pumps on or off. The same style of screen is available for Vessels 2 and 3, if installed and configured.

The most important information about the Condenser package is displayed here:

**DATE** - The actual date will be displayed in this box. The date must first be set correctly on the **Configuration** screen. Once set, the date is automatically adjusted at the end of each month, much like the calendar feature of most modern watches. The primary use of the date feature is to provide a date stamp for Warnings and Shutdowns. Refer to the section entitled *Setting the Date and Time* for further information.

**TIME** - The actual time will be displayed in this box. The time must first be set correctly on the **Configuration** screen. The time will also need to be adjusted for those locations which observe Daylight Savings Time. The primary use of the time feature is to provide a time stamp for Warnings and Shutdowns.

**SCREEN TITLE** - This is the title for the screen that is showing. Each screen will have a title. The Quantum™ LX manuals will extensively refer to screens by these names. When referred to in these manuals, screen names will be shown in bold italic print, such as **Operating Status**.

**CURRENT VESSEL BEING VIEWED** – This area shows the vessel number that is being viewed on the screen.

**PUMP STATUS BOX** - There are two pushbuttons located here:

- **Switch Pumps**
- **Pumps Off**

**SETPOINT VALUE** – This is the setpoint maintained by the control.

**ACTUAL VALUE** – The actual reading that was chosen as the control input.

**OPERATIONAL VALUES** – These values are set up on the *Condenser Step Configuration* screen:

- **Vessel Level**
- **Vessel Pressure**
- **Modulating Valve**

**DIGITAL STATUS BOX** - The status of the vessels outputs are displayed as one of the following messages:

- **On** – The input or output is energized.
- **Off** – The input or output is de-energized.
- **Open** – The solenoid is energized.
- **Closed** – The solenoid is de-energized.

**ALARM STATUS** - If a warning or shutdown condition exists, the name of the condition will be shown in red letters. The status box is blank if there are no alarms present.

**STATUS - Trending - Trending Setup**

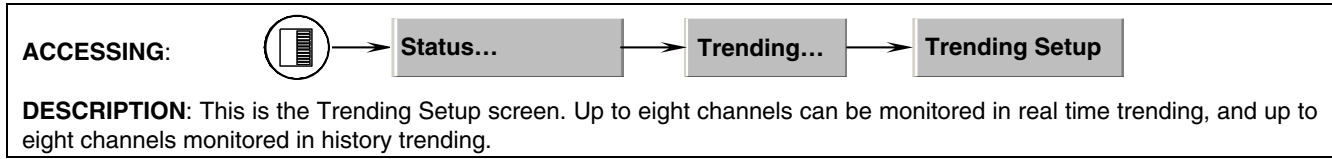
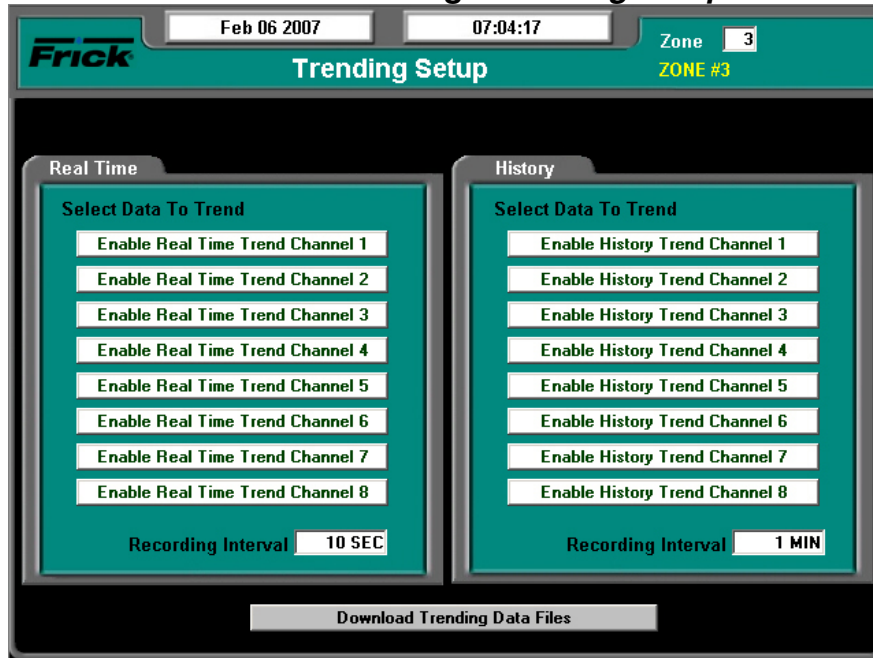

**Real Time Trending** - is a method by which the user can set the Quantum™ LX to map real-time events to a graphic chart format. Using this feature allows for a live snap-shot of recent unit process characteristics, such as temperature, pressure and humidity readings. The events that occur will scroll across the screen from left to right, at a speed that is determined by the recording interval. Real Time trending information is also stored to a log file, which provides a time/date stamp for each of the selected channels, as well as the value of the reading for that channel. This log file can be viewed on the *Real Time Data Log* screen. Trending data is lost upon power cycle.

The following setpoints are provided:

**Real Time Recording Interval** – The time interval that defines how often the real time trending data values are updated. This value may be set for any time duration between 1.0 second and 86,400.0 seconds (24 hours).

**History Trending** - is a method by which the user can set the Quantum™ LX to record historical events to a graphic chart format. This feature is similar to Real Time trending, except that the data points can be set separately, the rate at which the graphic chart is updated can be set to a different rate, and the data is not lost at power cycle. Using this feature allows for the recording of recent event characteristics, such as temperature, pressure and humidity readings. The events that occur will scroll across the screen, at a speed that is determined by the recording interval.

**History Recording Interval** – The time interval that defines how often the history trending data values are

updated. This value may be set for any time duration between 1.0 minute and 60.0 minutes (1 hour).

To program this screen with the data you wish to trend, highlight the Enable Real Time Trend Channel 1 (or whatever channel you wish to use), by selecting it with the mouse. Once the box has been selected, a drop down menu will appear for that channel. On the right hand side of the drop down box will be an arrow. Selecting the arrow will cause all the possible settings for the channel to appear. Use the mouse to scroll through the list. When the selection that you want to use appears, click on it to select it. Once selected, the value for this channel will be automatically trended and shown on the Real Time Trending graph (or History Trending Graph), as well as on the Real Time Trending Data Log (Or History Trending Data Log).

The following screen command keys are provided:

- Refrigerant Level – Vessel 1-3
- Vessel Pressure – Vessel 1-3
- Pump 1 Motor Amps – Vessel 1-3
- Pump 2 Motor Amps – Vessel 1-3
- Pump 3 Motor Amps – Vessel 1-3
- Pump 4 Motor Amps – Vessel 1-3
- Pump 1 High Side Pressure – Vessel 1-3
- Pump 2 High Side Pressure – Vessel 1-3
- Pump 3 High Side Pressure – Vessel 1-3
- Pump 4 High Side Pressure – Vessel 1-3
- Pump 1 Low Side Pressure – Vessel 1-3
- Pump 2 Low Side Pressure – Vessel 1-3
- Pump 3 Low Side Pressure – Vessel 1-3
- Pump 4 Low Side Pressure – Vessel 1-3

- Vessel Aux Analog 1–10
- Condenser Pressure
- Outside Air Temperature
- Outside Air Humidity
- Drain Temperature
- Condenser Aux Analog 1–10
- None

A window will appear on the computer screen, showing two files:

- Realtimexx.csv
- Historyxx.csv

The xx in both of these files will be replaced with the ID number of the Quantum™ LX. When the files appear in the screen window, simply right click on either file, and select from the menu “Save Target As...”, and save the files to a convenient location. By using Windows Internet Explorer™, you can then double click on the file, and it will automatically open the file in Microsoft Excel™. The data can then be used in whatever way the user would like.

When in Remote Mode (not at the panel), the following key is provided:

**Download Data Trending Files** – Clicking on this button initiates a downloading of the Real Time and History data files from the Quantum™ LX to the remote computer (the computer that you are monitoring from). These files can then be imported into a database such as Excel™.

### STATUS – Trending - Real Time Trending

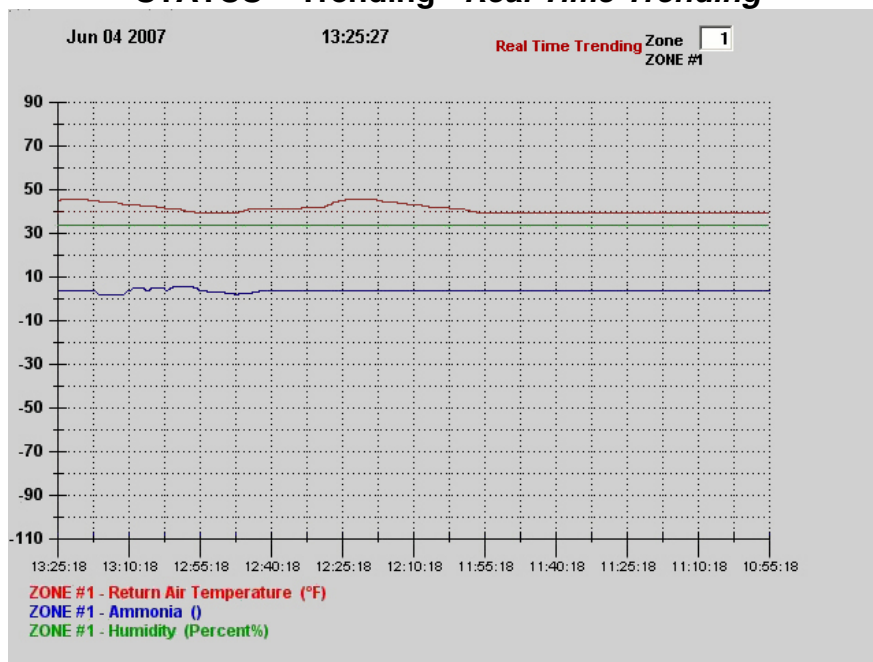

ACCESSING:



Status...

Trending...

Real Time Trending

**DESCRIPTION:** This is the *Real Time Trending* screen. This screen will display in a graphical chart format the data values as selected on the Real Time Trending Setup screen. Each of the possible eight selectable channels will be shown at the bottom of the screen, each in a different color. The color data values displayed in the chart correspond to the matching color of the trending channels at the bottom of the screen. A total of 900 Realtime events can be trended. Realtime events are lost upon each power cycle.

The following are the possible data channels that may be shown here:

- Refrigerant Level – Vessel 1 – 3
- Vessel Pressure – Vessel 1 -3
- Pump 1 Motor Amps – Vessel 1 -3
- Pump 2 Motor Amps – Vessel 1 -3
- Pump 3 Motor Amps – Vessel 1 -3
- Pump 4 Motor Amps – Vessel 1 -3
- Pump 1 High Side Pressure – Vessel 1 - 3
- Pump 2 High Side Pressure – Vessel 1 - 3
- Pump 3 High Side Pressure – Vessel 1 - 3
- Pump 4 High Side Pressure – Vessel 1 - 3
- Pump 1 Low Side Pressure – Vessel 1 - 3
- Pump 2 Low Side Pressure – Vessel 1 - 3
- Pump 3 Low Side Pressure – Vessel 1 - 3
- Pump 4 Low Side Pressure – Vessel 1 - 3
- Vessel Aux Analog 1 – 10
- Condenser Pressure
- Outside Air Temperature
- Outside Air Humidity
- Drain Temperature
- Condenser Aux Analog 1 – 10
- None

**STATUS – Trending – History Trending**

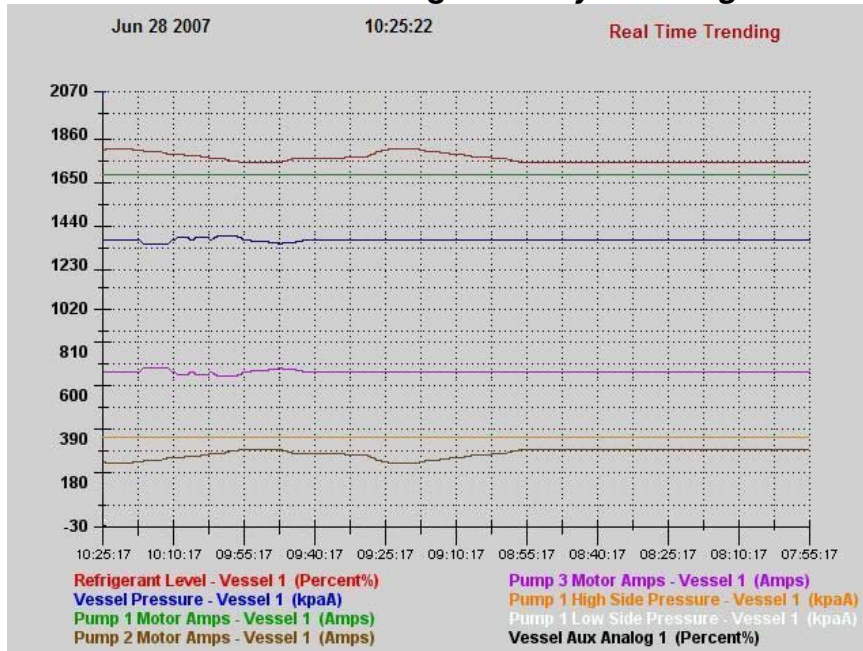

**ACCESSING:**  → **Status ...** → **Trending ...** → **History Trending**

**DESCRIPTION:** This is the *History Trending* screen. This screen will display in a graphical chart format the data values as selected on the *History Trending Setup* screen. Each of the possible eight selectable channels will be shown at the bottom of the screen, each in a different color. The color data values displayed in the chart correspond to the matching color of the trending channels at the bottom of the screen.

History trending can save up to 2000 values for each selected channel. History data is stored in Flash memory. Flash memory is non-volatile and all information is retained even if the power to the panel is lost. The interval at which the data is saved can be adjusted.

The following are the possible data channels that may be shown here:

- Refrigerant Level – Vessel 1 – 3
- Vessel Pressure – Vessel 1 -3
- Pump 1 Motor Amps – Vessel 1 -3
- Pump 2 Motor Amps – Vessel 1 -3
- Pump 3 Motor Amps – Vessel 1 -3
- Pump 4 Motor Amps – Vessel 1 -3
- Pump 1 High Side Pressure – Vessel 1 - 3
- Pump 2 High Side Pressure – Vessel 1 - 3
- Pump 3 High Side Pressure – Vessel 1 - 3
- Pump 4 High Side Pressure – Vessel 1 - 3
- Pump 1 Low Side Pressure – Vessel 1 - 3
- Pump 2 Low Side Pressure – Vessel 1 - 3
- Pump 3 Low Side Pressure – Vessel 1 - 3
- Pump 4 Low Side Pressure – Vessel 1 - 3
- Vessel Aux Analog 1 – 10
- Condenser Pressure
- Outside Air Temperature
- Outside Air Humidity
- Drain Temperature
- Condenser Aux Analog 1 – 10
- None

### STATUS - Trending – Real Time Data Log

Jun 28 2007		14:07:06		Real Time Data Log						
1	06/28/07 14:06:57	59.92	2068.50	0.00	0.00	0.00	0.00	0.00	0.00	-25.00
2	06/28/07 14:06:47	59.92	2068.50	0.00	0.00	0.00	0.00	0.00	0.00	-25.00
3	06/28/07 14:06:37	59.92	2068.50	0.00	0.00	0.00	0.00	0.00	0.00	-25.00
4	06/28/07 14:06:27	59.92	2068.50	0.00	0.00	0.00	0.00	0.00	0.00	-25.00
5	06/28/07 14:06:17	59.92	2068.50	0.00	0.00	0.00	0.00	0.00	0.00	-25.00
6	06/28/07 14:06:07	59.92	2068.50	0.00	0.00	0.00	0.00	0.00	0.00	-25.00
7	06/28/07 14:05:57	59.92	2068.50	0.00	0.00	0.00	0.00	0.00	0.00	-25.00
8	06/28/07 14:05:47	59.92	2068.50	0.00	0.00	0.00	0.00	0.00	0.00	-24.97
9	06/28/07 14:05:37	59.92	2068.50	0.00	0.00	0.00	0.00	0.00	0.00	-25.00
10	06/28/07 14:05:27	59.92	2068.50	0.00	0.00	0.00	0.00	0.00	0.00	-25.00
11	06/28/07 14:05:17	59.92	2068.50	0.00	0.00	0.00	0.00	0.00	0.00	-25.00
12	06/28/07 14:05:07	59.92	2068.50	0.00	0.00	0.00	0.00	0.00	0.00	-25.00
13	06/28/07 14:04:57	59.92	2068.50	0.00	0.00	0.00	0.00	0.00	0.00	-25.00
14	06/28/07 14:04:47	59.92	2068.50	0.00	0.00	0.00	0.00	0.00	0.00	-25.00
15	06/28/07 14:04:37	59.92	2068.50	0.00	0.00	0.00	0.00	0.00	0.00	-25.00
16	06/28/07 14:04:27	59.92	2068.50	0.00	0.00	0.00	0.00	0.00	0.00	-25.00
17	06/28/07 14:04:17	59.92	2068.50	0.00	0.00	0.00	0.00	0.00	0.00	-25.00
18	06/28/07 14:04:07	59.92	2068.50	0.00	0.00	0.00	0.00	0.00	0.00	-25.00
19	06/28/07 14:03:57	59.92	2068.50	0.00	0.00	0.00	0.00	0.00	0.00	-25.00
20	06/28/07 14:03:47	59.92	2068.50	0.00	0.00	0.00	0.00	0.00	0.00	-25.00
21	06/28/07 14:03:37	59.92	2068.50	0.00	0.00	0.00	0.00	0.00	0.00	-25.00
22	06/28/07 14:03:27	59.92	2068.50	0.00	0.00	0.00	0.00	0.00	0.00	-25.00

Refrigerant Level - Vessel 1 (Percent%)	Pump 3 Motor Amps - Vessel 1 (Amps)
Vessel Pressure - Vessel 1 (kpaA)	Pump 1 High Side Pressure - Vessel 1 (kpaA)
Pump 1 Motor Amps - Vessel 1 (Amps)	Pump 1 Low Side Pressure - Vessel 1 (kpaA)
Pump 2 Motor Amps - Vessel 1 (Amps)	Vessel Aux Analog 1 (Percent%)

**ACCESSING:** 

**DESCRIPTION:** This screen will display in a tabular format, the numerical data values as selected on the *Real Time Trending Setup* screen. Each trending channel will be listed at the bottom of the screen in a specific color that matches all data associated with that channel.

The following are the possible data channels that may be shown here:

- Refrigerant Level – Vessel 1 – 3
- Vessel Pressure – Vessel 1 -3
- Pump 1 Motor Amps – Vessel 1 -3
- Pump 2 Motor Amps – Vessel 1 -3
- Pump 3 Motor Amps – Vessel 1 -3
- Pump 4 Motor Amps – Vessel 1 -3
- Pump 1 High Side Pressure – Vessel 1 - 3
- Pump 2 High Side Pressure – Vessel 1 - 3
- Pump 3 High Side Pressure – Vessel 1 - 3
- Pump 4 High Side Pressure – Vessel 1 - 3
- Pump 1 Low Side Pressure – Vessel 1 - 3
- Pump 2 Low Side Pressure – Vessel 1 - 3
- Pump 3 Low Side Pressure – Vessel 1 - 3

- Pump 4 Low Side Pressure – Vessel 1 - 3
- Vessel Aux Analog 1 – 10
- Condenser Pressure
- Outside Air Temperature
- Outside Air Humidity
- Drain Temperature
- Condenser Aux Analog 1 – 10
- None

Up to eight of these data selections may be activated for recording at any one time. If eight items are selected, and you wish to view one more, you will first need to deactivate one that is already chosen first. Selected data items will appear with an asterisk (\*) in front of the data on this listing.

**STATUS - Trending – History Data Log**

Jun 28 2007		14:15:51		History Data Log	
1	06/28/07 14:15:22	59.92	2068.50	0.00	0.00
2	06/28/07 14:14:22	59.92	2068.50	0.00	0.00
3	06/28/07 14:13:22	59.92	2068.50	0.00	0.00
4	06/28/07 14:12:22	59.92	2068.50	0.00	0.00
5	06/28/07 14:11:22	59.92	2068.50	0.00	0.00
6	06/28/07 14:10:22	59.92	2068.50	0.00	0.00
7	06/28/07 14:09:22	59.92	2068.50	0.00	0.00
8	06/28/07 14:08:22	59.92	2068.50	0.00	0.00
9	06/28/07 14:07:22	59.92	2068.50	0.00	0.00
10	06/28/07 14:06:22	59.92	2068.50	0.00	0.00
11	06/28/07 14:05:22	59.92	2068.50	0.00	0.00
12	06/28/07 14:04:22	59.92	2068.50	0.00	0.00
13	06/28/07 14:03:22	59.92	2068.50	0.00	0.00
14	06/28/07 14:02:22	59.92	2068.50	0.00	0.00
15	06/28/07 14:01:22	59.92	2068.50	0.00	0.00
16	06/28/07 14:00:22	59.92	2068.50	0.00	0.00
17	06/28/07 13:59:22	59.92	2068.50	0.00	0.00
18	06/28/07 13:58:22	59.92	2068.50	0.00	0.00
19	06/28/07 13:57:22	59.92	2068.50	0.00	0.00
20	06/28/07 13:56:22	59.92	2068.50	0.00	0.00
21	06/28/07 13:55:22	59.92	2068.50	0.00	0.00
22	06/28/07 13:54:22	59.92	2068.50	0.00	0.00

Refrigerant Level - Vessel 1 (Percent%)  
 Vessel Pressure - Vessel 1 (kpaA)  
 Pump 1 Motor Amps - Vessel 1 (Amps)  
 Pump 2 Motor Amps - Vessel 1 (Amps)

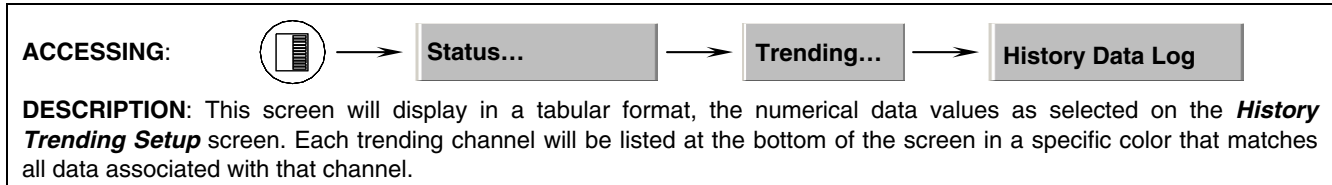

The following data channels may be shown here:

- Refrigerant Level – Vessel 1 – 3
- Vessel Pressure – Vessel 1 -3
- Pump 1 Motor Amps – Vessel 1 -3
- Pump 2 Motor Amps – Vessel 1 -3
- Pump 3 Motor Amps – Vessel 1 -3
- Pump 4 Motor Amps – Vessel 1 -3
- Pump 1 High Side Pressure – Vessel 1 - 3
- Pump 2 High Side Pressure – Vessel 1 - 3
- Pump 3 High Side Pressure – Vessel 1 - 3
- Pump 4 High Side Pressure – Vessel 1 - 3
- Pump 1 Low Side Pressure – Vessel 1 - 3
- Pump 2 Low Side Pressure – Vessel 1 - 3
- Pump 3 Low Side Pressure – Vessel 1 - 3
- Pump 4 Low Side Pressure – Vessel 1 - 3
- Vessel Aux Analog 1 – 10
- Condenser Pressure
- Outside Air Temperature
- Outside Air Humidity
- Drain Temperature
- Condenser Aux Analog 1 – 10
- None

### STATUS - Event Log

Frick		Jul 12 2007	09:31:23	Setpoint	0
Event Log				Actual	0
Event		Occurred			
01		01	Power Up	07-07-07	10:24:50
02		02	Power Down	06-29-07	13:59:21
03		03	Power Up	06-29-07	13:52:19
04		04	Power Down	06-29-07	13:51:14
05		05	Power Up	06-27-07	14:33:22
06		06	Power Down	06-27-07	14:32:39
07		07	Power Up	06-09-07	04:42:05
08		08	Power Down	06-09-07	04:40:53
09		09	Power Up	06-04-07	07:00:39
10		10	Power Down	06-04-07	06:58:11
11		11	Power Up	06-02-07	21:14:47
12		12	Power Down	06-02-07	20:32:31
13		13	Power Up	05-31-07	03:31:48
14		14	Power Down	05-31-07	03:30:48
15		15	Power Up	05-30-07	13:40:38
16		16	Power Down	05-30-07	13:36:14
17		17	Power Up	05-30-07	13:36:13
18		18	Power Down	05-30-07	13:31:42
19		19	Power Up	05-29-07	12:35:28
20		20	Power Down	05-29-07	12:30:21
21		21	Power Up	05-18-07	08:20:47
22		22	Power Down	05-18-07	08:19:44
23		23	Power Up	05-20-07	10:04:30
24		24	Power Down	05-20-07	10:02:43

**ACCESSING:**  → **Status...** → **Event Log**

**DESCRIPTION:** This screen is used to log certain messages and events that are generated through normal unit operation. Occurrences such as normal power up and power down sequences, as well as all maintenance schedule messages (see the *Maintenance* screen for more information on these messages).

The messages that appear on this screen cannot be cleared, they will be stored indefinitely. The user can use

the arrow keys on the keypad to scroll down through the list.

**SAFETIES - Current Safeties**

Frick		Jun 28 2007	14:21:54	Clear Safeties
Current Safeties - Vessel 1				
Safety	Occurred			
01 Vessel Aux Analog 10 LowWarning	06-28-07 08:29:30			
02 Vessel Aux Analog 7 LowWarning	06-28-07 08:29:30			
03 Vessel Aux Analog 4 LowWarning	06-28-07 08:29:29			
04 Vessel Aux Analog 1 LowWarning	06-28-07 08:29:29			
05 Auxiliary Input 7 Warning	06-28-07 08:29:28			
06 Auxiliary Input 4 Warning	06-28-07 08:29:28			
07 Auxiliary Input 1 Warning	06-28-07 08:29:27			
08 Low Level Shutdown Digital Input	06-28-07 08:29:09			
09 Low Level Warning Digital Input	06-28-07 08:29:09			
10 High Level Shutdown Digital Input	06-28-07 08:29:08			
11 High Level Warning Digital Input	06-28-07 08:29:08			
12 Pump 4 Lo Side Press. Sensor Fault	06-28-07 08:28:52			
13 Pump 4 Hi Side Press. Sensor Fault	06-28-07 08:28:51			
14 Pump 3 Lo Side Press. Sensor Fault	06-28-07 08:28:50			
15 Pump 3 Hi Side Press. Sensor Fault	06-28-07 08:28:50			
16 Pump 2 Lo Side Press. Sensor Fault	06-28-07 08:28:49			
17 Pump 2 Hi Side Press. Sensor Fault	06-28-07 08:28:48			
18 Pump 1 Lo Side Press. Sensor Fault	06-28-07 08:28:48			
19 Pump 1 Hi Side Press. Sensor Fault	06-28-07 08:28:48			

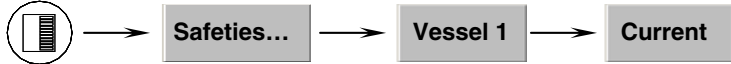
**ACCESSING:** 

**DESCRIPTION:** The **Current Safeties** screen shows the Warnings and Shutdowns that have recently occurred (up to 50). When a warning or shutdown is triggered, a blue descriptive message shows on this screen. The date and time of the warning or shutdown occurrence is shown to the right of its description. The most recent message will appear on the top line of the screen with the oldest appearing at the bottom. When a Warning or Shutdown is logged to this screen, it will also be logged to the **Safety History** screen. This same style of screen also exists for the Condenser, as well as any additional Vessels.

The following **Current Safeties** screen key is provided:

**[Clear Safeties]** - Selecting this key will clear all warnings and/or shutdowns from this screen. This will also place a date/time stamp for the corresponding entry on the **Safety History** screen showing that the particular Warning or Shutdown was cleared. Clearing the entry on the **Current Safeties** screen, will not clear it from the **Safety History** screen.

To resume normal operation it will be necessary to go through the following steps:

1. Correct the condition(s) causing the warning.
2. Press the **[ALARM SILENCE]** key. (This action may precede correcting the condition(s) causing the warning). Or, go to step 3.

3. To clear or reset the **Warnings/Shutdowns** screen and turn off any warning annunciation device, from the screen, press the **[Clear Safeties]** key. This will also clear the **WARNING** or **SHUTDOWN** message from the **Operating Status** screen.
4. If the conditions causing the warning have not been corrected or a new fault has occurred, a new **WARNING** or **SHUTDOWN** message will appear. The **Safety History** screen keeps a record of the warnings and shutdowns. This information will help troubleshoot persistent operational problems.

Refer to the **Warnings/Shutdowns Message** section for a list of all the possible conditions.

### SAFETIES - Safety History

Jun 28 2007		14:28:45		Clear Safety History	
Frick Safety History - Vessel 1					
Safety		Occurred		Cleared	
01	Vessel Aux Analog 10 LowWarning	06-28-07 08:29:30			
02	Vessel Aux Analog 7 LowWarning	06-28-07 08:29:30			
03	Vessel Aux Analog 4 LowWarning	06-28-07 08:29:29			
04	Vessel Aux Analog 1 LowWarning	06-28-07 08:29:29			
05	Auxiliary Input 7 Warning	06-28-07 08:29:28			
06	Auxiliary Input 4 Warning	06-28-07 08:29:28			
07	Auxiliary Input 1 Warning	06-28-07 08:29:27			
08	Low Level Shutdown Digital Input	06-28-07 08:29:09			
09	Low Level Warning Digital Input	06-28-07 08:29:09			
10	High Level Shutdown Digital Input	06-28-07 08:29:08			
11	High Level Warning Digital Input	06-28-07 08:29:08			
12	Pump 4 Lo Side Press. Sensor Fault	06-28-07 08:28:52			
13	Pump 4 Hi Side Press. Sensor Fault	06-28-07 08:28:51			
14	Pump 3 Lo Side Press. Sensor Fault	06-28-07 08:28:50			
15	Pump 3 Hi Side Press. Sensor Fault	06-28-07 08:28:50			
16	Pump 2 Lo Side Press. Sensor Fault	06-28-07 08:28:49			
17	Pump 2 Hi Side Press. Sensor Fault	06-28-07 08:28:48			
18	Pump 1 Lo Side Press. Sensor Fault	06-28-07 08:28:48			
19	Pump 1 Hi Side Press. Sensor Fault	06-28-07 08:28:48			
20	Vessel Aux Analog 10 LowWarning	06-27-07 14:34:30		06-28-07 08:28:45	
21	Vessel Aux Analog 7 LowWarning	06-27-07 14:34:29		06-28-07 08:28:45	
22	Vessel Aux Analog 4 LowWarning	06-27-07 14:34:29		06-28-07 08:28:45	
23	Vessel Aux Analog 1 LowWarning	06-27-07 14:34:29		06-28-07 08:28:45	
24	Auxiliary Input 7 Warning	06-27-07 14:34:28		06-28-07 08:28:45	

ACCESSING:



Safeties

Vessel 1

History

**DESCRIPTION:** The **Safety History** screen shows the warnings and shutdowns that have recently occurred (up to 50 maximum). When a warning or shutdown is triggered, a blue descriptive message shows on this screen. The date and time of the warning or shutdown occurrence is shown to the right of its description, followed by the date and time that the safety was cleared. The most recent message will appear on the top line of the screen with the oldest appearing at the bottom.

It is possible to view the conditions that existed on the **Operating Status** screen at the exact moment that a condition occurred. Use the mouse to select (highlight) a warning or shutdown and then click on it to view its associated **Freeze (Operating Status)** screen.

#### Freeze Screen Description

This **Freeze** screen provides a snapshot of the values that were current at the time of the latest shutdown. The information on the **Freeze** screen can help the user to identify the cause of a fault, which occurred when no one was present. The **Freeze** screen freezes

the information of the **Operating Status** screen AT THE MOMENT OF AN EVAPORTOR WARNING OR SHUTDOWN. The Freeze screen has the same appearance and contains the same information as the **Operating Status** screen. (For a description of the information presented by the **Freeze** screen, refer to the **Operating Status** screen). The **Freeze** screen will retain the information generated by a warning or shutdown. The last fifty warnings/shutdowns **Freeze** screens are saved. This data is saved during a power outage.

**SETPOINTS – Condenser Step Control**

The screenshot shows the 'Step Control' interface with a date of Jun 28 2007 and time of 15:11:21. It is divided into two columns: Summer and Winter. Each column has several input fields for setpoints and control parameters. The Summer column includes Control Setpoint (1637.4 PSIG), Defrost Setpoint (135.3 PSIG), Dead Band (Upper/Lower: 1.0 PSIG), Delay (20 SEC), Proportional Band (1.0 PSIG), Integration Time (30 SEC), Wet Bulb Temperature (57904219/259.2), Wet Bulb Approach (15.0 °F), and Control Temperature (57904219/259.2). The Winter column includes Control Setpoint (1637.4 PSIG), Defrost Setpoint (135.3 PSIG), Dead Band (Upper/Lower: 1.0 PSIG), Delay (20 SEC), Proportional Band (1.0 PSIG), Integration Time (30 SEC), Minimum Condensing Pressure (105.3 PSIG), Refrigerant (R717), Outside Air Temperature Control (Automatic), Summer Mode On (65.0 °F), and Winter Mode On (60.0 °F). At the bottom, there are dropdown menus for Control Strategy (Wet Bulb), Defrost Control (Enabled), and PI Step Control (Enabled).

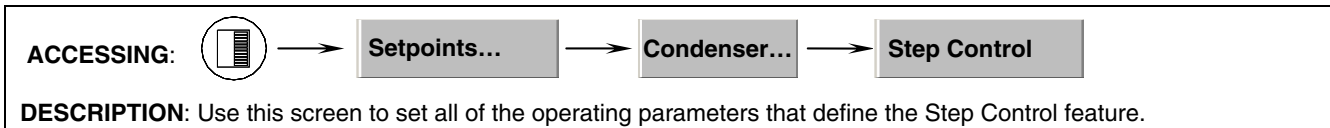

The Summer On Sequence determines the order in which the condenser steps or outputs are turned on and off when the condenser is in Summer Mode. As it turns on outputs, the controller will move up the sequence from low to high numbers. As there are a maximum number of twenty-four possible steps, the range for sequence values is zero to twenty-four. Numbers can be repeated in which case the IO Position order will determine which output is turned on first. When two-speed fans are used, the only requirement is that the sequence number for the low speed output is less than the sequence number for the high-speed output.

There is also a set of Winter On Sequence Setpoints that are used by the controller when the condenser is in Winter Mode.

Step Control Setpoints are used to maintain pressure. A PID loop is the control structure used to move the pressure toward setpoint. The *Proportional Band* and *Integration Time* Setpoints allows for the configuration of this PID control.

This screen provides setpoint boxes to allow for the configuration of Summer and Winter Step Control:

**Summer**

**Control Setpoint** – This is the value that the Condenser will attempt to maintain for Summer cooling. If Wet Bulb has been enabled, then this setpoint box will be replaced with a calculated value based upon the Wet Bulb reading.

**Defrost Setpoint** - When the Defrost Input is energized and enabled, this setpoint becomes the controlling value for the turning on and off condenser steps or digital outputs. In this situation, the difference between the discharge pressure and this setpoint also controls the signal strength of the variable fan analog output.

**Dead Band**

**Upper** - A pressure buffer above the condenser control setpoint where the condenser digital outputs will not be turned on.

**Lower** - A pressure buffer below the condenser control setpoint where the condenser digital outputs will not be turned off.

**Delay**

**Upper** - After the Condenser Pressure rises above the control setpoint plus the dead band or an output has been turned on, this setpoint is the minimum time in seconds before the next output can be turned on.

**Lower** - After the Condenser Pressure drops below the control setpoint minus the dead band or an output has been turned off, this setpoint is the minimum time is seconds before the next output can be turned off.

**Proportional Band** – The pressure range over which the PID control will be managing liquid cooling (provided *Integration Time* is not set to zero, in which case it will be strictly proportional).

**Integration Time** – This setpoint controls the influence that the Integral component exerts on the PID Output value. The Integral component works to push the *Control Input* toward the *Control Setpoint* by tracking the difference between the *Control Input* and the *Control Setpoint* over time.

**Wet Bulb Temperature** – The value shown here is the reading that the controller is receiving from the *Wet Bulb*. This value is used in calculating the Control Setpoint when *Wet Bulb* is enabled.

#### Wet Bulb Approach

#### Control Temperature

#### Control Strategy

- Standard
- Wet Bulb

#### Defrost Control

- Disabled
- Enabled

#### PI Step Control

- Disabled
- Enabled

#### Winter

**Control Setpoint** - This is the value that the Condenser will attempt to maintain for Summer cooling. If Wet Bulb has been enabled, then this setpoint box will be replaced with a calculated value based upon the Wet Bulb reading.

**Defrost Setpoint** - When the Defrost Input is energized and enabled, this setpoint becomes the controlling value for the turning on and off condenser steps or digital outputs. In this situation, the difference between the discharge pressure and this setpoint also controls the signal strength of the variable fan analog output.

#### Dead Band

**Upper** - A pressure buffer above the condenser control setpoint where the

condenser digital outputs will not be turned on.

**Lower** - A pressure buffer below the condenser control setpoint where the condenser digital outputs will not be turned off.

#### Delay

**Upper** - After the Condenser Pressure rises above the control setpoint plus the dead band or an output has been turned on, this setpoint is the minimum time in seconds before the next output can be turned on.

**Lower** - After the Condenser Pressure drops below the control setpoint minus the dead band or an output has been turned off, this setpoint is the minimum time in seconds before the next output can be turned off.

**Proportional Band** – The pressure range over which the PID control will be managing liquid cooling (provided *Integration Time* is not set to zero, in which case it will be strictly proportional).

**Integration Time** – This setpoint controls the influence that the Integral component exerts on the PID Output value. The Integral component works to push the *Control Input* toward the *Control Setpoint* by tracking the difference between the *Control Input* and the *Control Setpoint* over time.

#### Minimum Condensing Pressure

#### Refrigerant

- R22
- R134a
- R717
- R744

#### Outside Air Temperature Control

- Manual
- Automatic

**Summer Mode On** - If the Outside Air Temperature rises above this setpoint, the program switches to Summer Mode.

**Winter Mode On** - If the Outside Air Temperature drops below this setpoint, the program switches to Winter Mode.

**SETPOINTS – Condenser Summer Sequence**

**Frick**
Jun 28 2007 15:16:35

**Summer Sequence**

Step	Name	Sequence		Step	Name	Sequence	
		On	Off			On	Off
1	Single Speed Fan #1	0	0				
2	Two Speed Fan Lo #2	0	0				
3	Two Speed Fan Lo #3	0	0				
4	Var Speed Fan #4	0	0				
5	Water Pump #5	0	0				

Note: 0 Indicates Step Not In Use

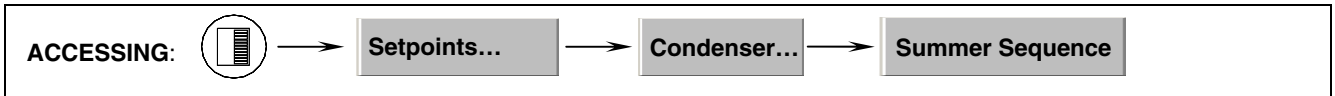

**SETPOINTS – Condenser Winter Sequence**

**Frick**
Jun 28 2007 15:21:29

**Winter Sequence**

Step	Name	Sequence		Step	Name	Sequence	
		On	Off			On	Off
1	Single Speed Fan #1	0	0				
2	Two Speed Fan Lo #2	0	0				
3	Two Speed Fan Lo #3	0	0				
4	Var Speed Fan #4	0	0				
5	Water Pump #5	0	0				

Note: 0 Indicates Step Not In Use

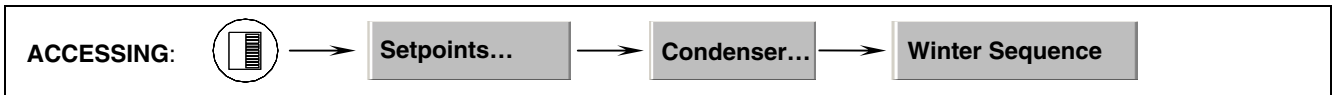

### SETPOINTS – *Condenser Variable Speed Fan*

Parameter	Value
Proportional Band	1.0 PSIG
Integration Time	30 SEC
Maximum	100
Minimum	30

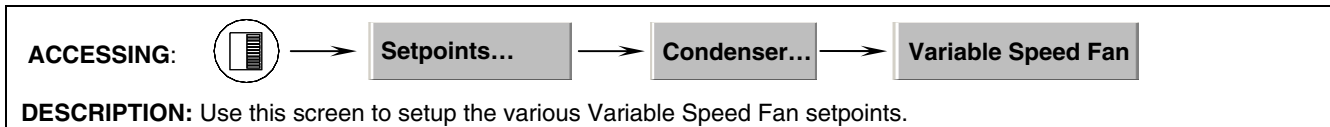

This screen allows the user to optimize the settings for a Variable Speed Fan.

The following setpoint boxes are provided:

- **Proportional Band** – The range over which the PID control will be managing the Variable Speed Fan (provided *Integration Time* is not set to zero, in which case it will be strictly proportional).
- **Integration Time** – This setpoint controls the influence that the Integral component exerts on the PID Output value. The Integral component

works to push the *Control Input* toward the *Control Setpoint* by tracking the difference between the *Control Input* and the *Control Setpoint* over time.

- **Maximum** – The percentage of 4-20 mA which should be considered full On (usually 100%).
- **Minimum** – The percentage of 4-20mA which should be considered full Off (usually 0%).

**SETPOINTS – Condenser Control Overrides**

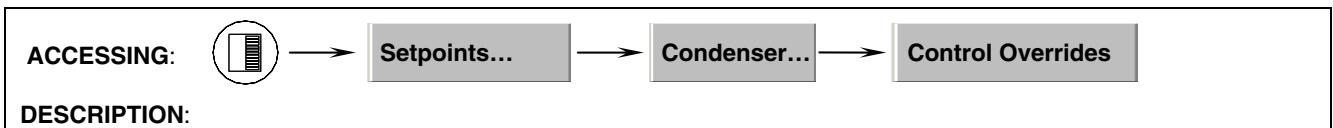
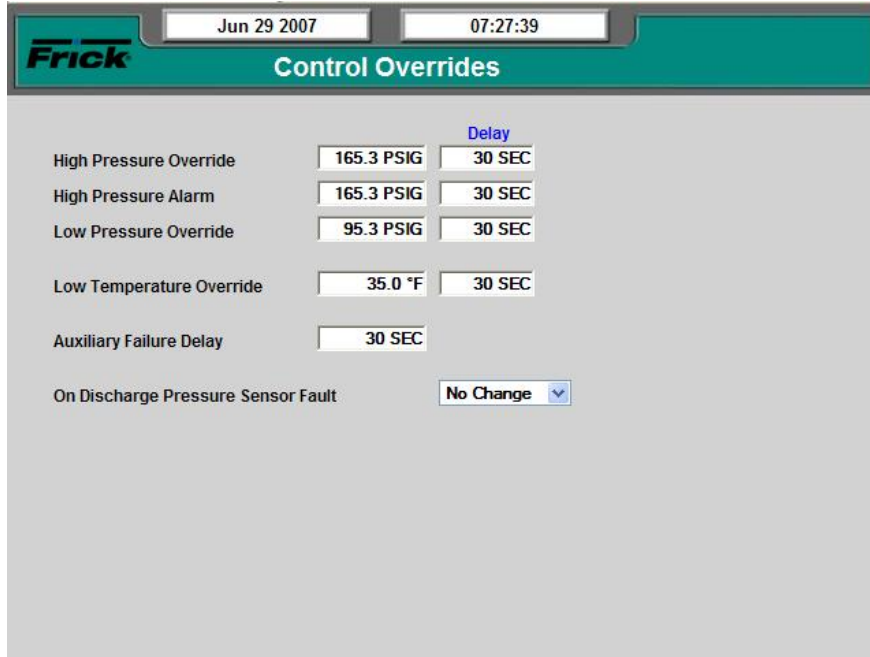

The following setpoint boxes appear on this screen:

- **High Pressure Override**– If the Condenser Pressure is greater than or equal to this setpoint for the alarm time delay, all condensing steps will be turned on.
- **Delay** – The time in seconds that the Condenser Pressure is greater than or equal to the High Pressure Override Setpoint before the override condition occurs.
- **High Pressure Alarm** - If the Condenser Pressure is greater than or equal to this setpoint for the alarm time delay, a warning occurs.
- **Delay** – The time in seconds that the Condenser Pressure is greater than or equal to the High Pressure Alarm Setpoint before a warning is triggered.
- **Low Pressure Override** – If the Condenser Pressure is less than or equal to this setpoint for the alarm time delay, all condensing steps will be turned off.
- **Delay** – The time in seconds that the Condenser Pressure is less than or equal to

the Low Pressure Override Setpoint before the override condition occurs.

- **Low Temperature Override** – If the Outside Air Temperature is less than or equal to this setpoint for the alarm time delay and the condenser is not in a High Pressure Override condition, all water pumps whose Outside Air Stop setting is enabled will be turned off.
- **Delay** – The time in seconds that the Outside Air Temperature is less than or equal to the Low Temperature Override Setpoint before the override condition occurs.
- **Auxiliary Failure Delay**

The following drop down menu selection appears on this screen:

- **On Discharge Pressure Fault**
  - **No Change**
  - **All Steps On**

## SETPOINTS – Vessel 1 Level Control

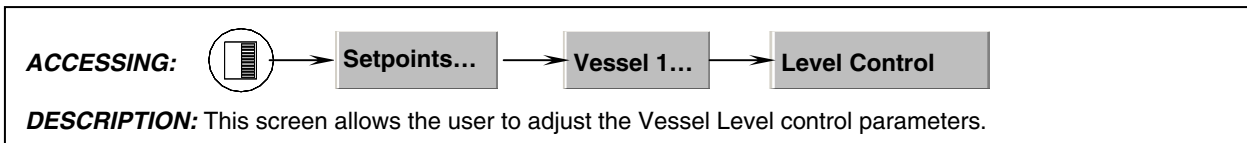

The following drop down menus and setpoint boxes appear on this screen:

**Analog Control** (a drop down menu appears to select between the following):

- Disabled
- Enabled

Setpoint boxes are provided for the following values:

- **Setpoint** – The controller works to maintain the Vessel Level at this setpoint.
- **Proportional Band** – This value is used to calculate the proportional part of the analog output when the Vessel Level is above or below the Control Setpoint by this percentage.
- **Integration Time** This value is used to calculate the integral part of the analog output when the Vessel Level is above the Control Setpoint. A short amount of time will cause the output to respond faster to changes in the Vessel Level while a longer length of time will cause the output to respond slower. A setpoint of 0 will disable the integral calculation and will cause the control to be strictly proportional.

- Maximum
- Minimum

### Digital Control

The following drop down menus are provided:

- Control Input
  - Disabled
  - Analog (one or two solenoids)
  - Digital (one or two solenoids)

When the *Control Input* is set for *Analog*, the following additional setpoint boxes appear:

- **Solenoid 1 On** – If the Vessel Level is less than this setpoint for the Delay period of time, the Solenoid 1 output will be turned on.
- **Solenoid 1 On Delay** – The number of seconds that the Vessel Level must remain below the Solenoid 1 On setpoint before the Solenoid 1 output is turned on.
- **Solenoid 1 Off** – If the Vessel Level is greater than this setpoint for the Delay period of time, the Solenoid 1 output will be turned off.
- **Solenoid 1 Off Delay** – The number of seconds that the Vessel Level must remain

above the Solenoid 1 On setpoint before the Solenoid 1 output is turned off.

of time, the Solenoid 2 output will be turned off.

- **Solenoid 2 On** – If the Vessel Level is less than this setpoint for the Delay period of time, the Solenoid 2 output will be turned on.
- **Solenoid 2 On Delay** – The number of seconds that the Vessel Level must remain below the Solenoid 2 On setpoint before the Solenoid 2 output is turned on.
- **Solenoid 2 Off** – If the Vessel Level is greater than this setpoint for the Delay period

- **Solenoid 2 Off Delay** – The number of seconds that the Vessel Level must remain above the Solenoid 2 On setpoint before the Solenoid 2 output is turned off.

**SETPOINTS – Vessel 1 Pump Control**

The screenshot shows the 'Vessel 1 Pump Control' interface with the following settings:

	Pump #1	Pump #2	Pump #3	Pump #4		
Run Time	23 HRS	0 HRS	0 HRS	0 HRS		
	<input type="button" value="Time Reset"/>	<input type="button" value="Time Reset"/>	<input type="button" value="Time Reset"/>	<input type="button" value="Time Reset"/>		
Pressure Diff. Control	Enabled	Enabled	Enabled	Enabled	Diff. Delay	Off Time
Min. Pressure Diff.	10.0 PSID	10.0 PSID	10.0 PSID	10.0 PSID	10 SEC	4 MIN
Pump Bypass Control	Enabled	Enabled	Enabled	Enabled	Bypass Delay	
Bypass Pressure Diff.	30.0 PSID	30.0 PSID	30.0 PSID	30.0 PSID	10 SEC	
Bypass Valve	Closed	Closed	Closed	Closed		
Low Level Shutdown Off Time	20 SEC			Switch Pumps Automatically	Enabled	
Max Pump Shutdowns Per Hour	6			Run Interval	100 HRS	
Compressor Run Input	Enabled			Pump #1	Enabled	
Compressor Run Input Delay	10 SEC			Pump #2	Enabled	
Pump Auxiliary Delay	10 SEC			Pump #3	Enabled	
				Pump #4	Enabled	
				Number Of Running Pumps	1	

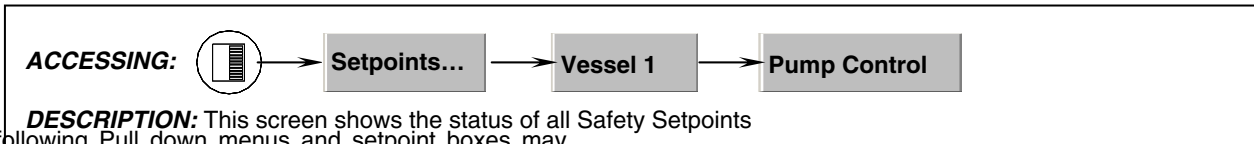

The following Pull down menus and setpoint boxes may appear on this screen (depending on configuration):

- **Pump # 1 - 4**
  - Time Reset (pushbutton)
  - Pressure Differential Control
    - Disabled
    - Enabled
  - Min. Pressure Differential (setpoint)
  - Pump Bypass Control
    - Disabled
    - Enabled
- Min. Pressure Diff. Delay
- Min. Pressure Diff. Off Time
- Bypass Pressure Diff. Bypass Delay
- Low Level Shutdown Off Time
- Switch Pumps Automatically
  - Disabled
  - Enabled
- Run Interval
- Max Pump Shutdowns Per Hour
- Compressor Run Input
  - Disabled
  - Enabled
- Compressor Run Input Delay
- Pump Auxiliary Delay
- Pump # 1 - 4
  - Disabled
  - Enabled
- Pump # 1 - 4 Pump Aux.
  - Disabled
  - Enabled
- Number of Running Pumps
  - 1
  - 2
  - 3
  - 4

### SETPOINTS – Vessel Safeties

Parameter	Value	Delay
High Level Shutdown		10 SEC
High Level Warning	80.0 %	10 SEC
Low Level Warning	20.0 %	10 SEC
Low Level Shutdown	10.0 %	10 SEC

Safety Type	Status
Analog Input Safeties	Enabled
High Level Shutdown Digital Input	Enabled
High Level Warning Digital Input	Enabled
Low Level Warning Digital Input	Enabled
Low Level Shutdown Digital Input	Enabled

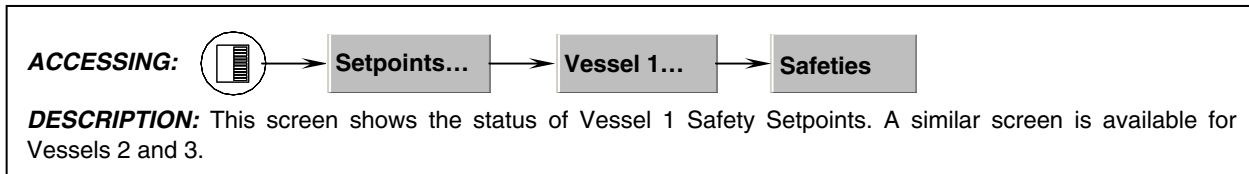

The following setpoint boxes appear on this screen:

- **High Level Shutdown Delay** – The amount of time the High Level Shutdown digital input must be on before a shutdown will occur.
- **High Level Warning** - – If the Vessel Level rises above this setpoint for the Delay period of time, a High Level warning will occur.
- **Delay** – The amount of time the High Level Alarm digital input must be on or the Vessel Level must be above the High Level Warning setpoint before a warning will occur.
- **Low Level Warning** - If the Vessel Level drops below this setpoint for the Delay period of time, a Low Level Alarm will occur.
  - **Delay** - The amount of time the Low Level Alarm digital input must be on or the Vessel Level must be below the Low Level Warning setpoint before a warning will occur.
- **Low Level Shutdown** - – If the Vessel Level drops below this setpoint for the Delay period of time, a Low Level Shutdown alarm will occur.

- **Delay** - The amount of time the Low Level Shutdown digital input must be on or the Vessel Level must be below the Low Level Shutdown setpoint before a shutdown will occur.

The following pull down menus appear on this screen:

- **Analog Input Safeties**
  - Disabled
  - Enabled
- **High Level Shutdown Digital Input**
  - Disabled
  - Enabled
- **High Level Warning Digital Input**
  - Disabled
  - Enabled
- **Low Level Warning Digital Input**
  - Disabled
  - Enabled
- **Low Level Shutdown Digital Input**
  - Disabled
  - Enabled

### SETPOINTS – PID Setup - Condenser

	PID #1	PID #2	PID #3	PID #4
Name				
Control	Enabled	Enabled	Enabled	Enabled
Action	Forward	Forward	Forward	Forward
Control Point	Pressure	Pressure	Pressure	Pressure
Device Source	None	None	None	None
Device Channel	0	0	0	0
Output	100.0 %	100.0 %	100.0 %	100.0 %
Actual	71.8 PSIG	71.8 PSIG	71.8 PSIG	71.8 PSIG
Setpoint	50.0 %	50.0 %	50.0 %	50.0 %
Proportional Band	5.0 %	5.0 %	5.0 %	5.0 %
Integration Time	30 SEC	30 SEC	30 SEC	30 SEC
High Limit	100.0 %	100.0 %	100.0 %	100.0 %
Low Limit	0.0 %	0.0 %	0.0 %	0.0 %

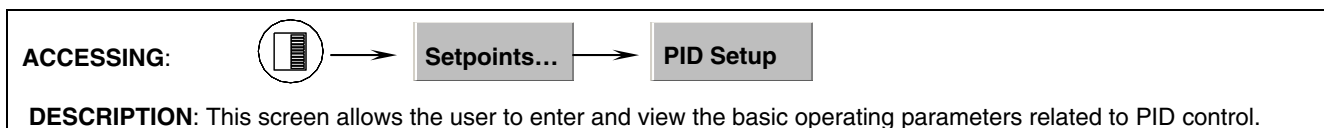

The following are the **PID Setup** screen selections:

**[Name]** - A user defined name can be entered here.

**[Control]** - A drop down menu is provided to select from the following:

- **Disabled** - No PID control.
- **Enabled** - PID Control only controls when the Condenser is running.

**[Action]** - A drop down menu is provided to select from the following:

- **Forward** - Will increase the output at values greater than the Control Setpoint.
- **Reverse** - Will increase the output at values less than the Control Setpoint.

**[Control Point]** - A drop down menu is provided to select from the following:

- Pressure
- Outside Air Temperature
- Outside Air Humidity
- Drain Temperature
- Condenser Aux Analog 1 – 10

**[Device Source]** - A drop down menu is provided to select from the following:

- None
- Analog Board 1
- Analog Board 2
- Analog Board 3

**[Device Channel]** - A setpoint entry box is provided to select the analog board output channel that you wish to use.

**[Output]** - The value of the Output signal as controlled by the PID. This is not a setpoint value.

**[Actual]** - The Actual value of the input signal. This is not a setpoint value.

**[Setpoint]** - Enter the value that you wish to control to.

**[Proportional Band]** – This setpoint determines the size of a region either above or below the *Control Setpoint*. Within this region, the output is governed by the PID control, and assumes a value between high limit and low limit. Outside of this region, the Proportional component is either 100% or 0%. If the PID's *Action* is *Forward*, the *Proportional Band* extends above the *Control Setpoint*. If the PID's *Action* is *Reverse*, the *Proportional Band* extends below the *Control Setpoint*.

**[Integration Time]** - This setpoint controls the influence that the Integral component exerts on the PID Output value. The Integral component works to push the *Control Input* toward the *Control Setpoint* by tracking the difference between the *Control Input* and the *Control Setpoint* over time.

**[High Limit]** - The highest value that the output can be.

**[Low Limit]** - The lowest value that the output can be.

**[When Running Off Value]** - If the PID's Control is *When Running*, this value sets the value of the PID output when the Condenser is off.

### SETPOINTS – PID Setup - Vessel

	PID #1	PID #2	PID #3	PID #4
Name	Vessel 1	Vessel 2	Vessel 3	Vessel 1
Control	Forward	Forward	Forward	Forward
Action	Refrigerant L	Refrigerant L	Refrigerant L	Refrigerant L
Control Point	Analog Board	Analog Board	Analog Board	Analog Board
Device Source	4	5	6	7
Device Channel				
Output	100.0 %	0.0 %	0.0 %	100.0 %
Actual	59.9 %	18.5 %	0.7 %	59.9 %
Setpoint	50.0 %	50.0 %	50.0 %	50.0 %
Proportional Band	5.0 %	5.0 %	5.0 %	5.0 %
Integration Time	30 SEC	30 SEC	30 SEC	30 SEC
High Limit	100.0 %	100.0 %	100.0 %	100.0 %
Low Limit	0.0 %	0.0 %	0.0 %	0.0 %

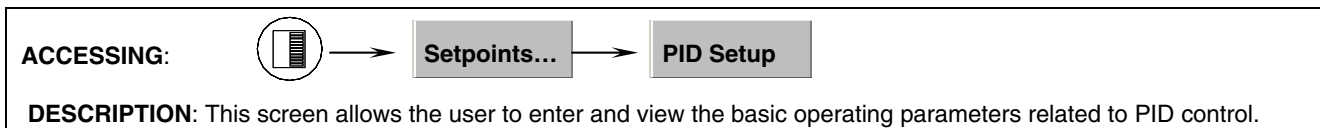

The following are the **PID Setup** screen selections:

**[Name]** - A user defined name can be entered here.

**[Control]** - A drop down menu selects the following:

- **Disabled** - No PID control.
- **Vessel 1** - PID Control only controls when the Vessel 1 is running.
- **Vessel 2** - PID Control only controls when the Vessel 2 is running.
- **Vessel 3** - PID Control only controls when the Vessel 3 is running.

**[Action]** - A drop down menu selects the following:

- **Forward** - Will increase the output at values greater than the Control Setpoint.
- **Reverse** - Will increase the output at values less than the Control Setpoint.

**[Control Point]** - A drop down menu is provided to select from the following:

- Refrigerant Level
- Pressure
- Pump 1-4 High Side Pressure
- Pump 1-4 Low Side Pressure
- Pump 1-4 Motor Amps
- Vessel Aux Analog 1 – 10

**[Device Source]** - A drop down menu is provided to select from the following:

- None
- Analog Board 1

- Analog Board 2
- Analog Board 3

**[Device Channel]** - A setpoint entry box is provided to select the analog board output channel that you wish to use.

**[Output]** - The value of the Output signal as controlled by the PID. This is not a setpoint value.

**[Actual]** - The Actual value of the input signal. This is not a setpoint value.

**[Setpoint]** - Enter the value that you wish to control to.

**[Proportional Band]** – This setpoint determines the size of a region either above or below the *Control Setpoint*. Within this region, the output is governed by the PID control, and assumes a value between high limit and low limit. Outside of this region, the Proportional component is either 100% or 0%. If the PID's *Action* is *Forward*, the *Proportional Band* extends above the *Control Setpoint*. If the PID's *Action* is *Reverse*, the *Proportional Band* extends below the *Control Setpoint*.

**[Integration Time]** - This setpoint controls the influence that the Integral component exerts on the PID Output value. The Integral component works to push the *Control Input* toward the *Control Setpoint* by tracking the difference between the *Control Input* and the *Control Setpoint* over time.

**[High Limit]** - The highest value that the output can be.

**[Low Limit]** - The lowest value that the output can be.

**[When Running Off Value]** - If the PID's Control is *When Running*, this value sets the value of the PID output when the Vessel is off.

### Setting up a PID Channel

**NOTE:** The basic steps in setting up a device for PID control are:

#### Setup Input channel

- First, decide which physical input channel you will be using. **Note:** If you wish to use an Auxiliary Analog channel, it will need to be completely setup as its own channel before attempting the remainder of this procedure.

#### Setup PID parameters

- From the **Operating Status** screen, access the Menu. Select the [Setpoints] item. From the Setpoints menu, select *PID Setup*. Finally, on the *PID Setup* menu, select [Condenser] or [Vessel].
- On the *PID Setup* screen, use the [Tab] key to access the Analog channel that has already been set up, in this case, channel 1.
- It is on this Setup screen that the remainder of the PID parameters are entered. For a detailed description of these parameters, refer to the *Overview to Tuning a PID Controller*.

**Note:** Each device that is utilized for PID control must also be properly calibrated.

### Overview to Tuning a PID Controller

The purpose of this section is to give some basic guidelines for tuning Proportional, Integral, and Differential gains of a PID controller. To tune a PID controller, it would be advantageous to hook the system up to some test equipment to allow you to record the appropriate variables. At the very least, the appropriate data will have to be monitored and recorded by hand from the system screen for subsequent evaluation and possible spreadsheet graphing.

**Proportional Band** - The *Proportional Band* setpoint translates the *Proportional Gain* into the units of the *Control Input* channel. When the control Input is at the *Control Setpoint*, the Proportional component of the PID Output will be 0%. As the *Control Input* moves through the *Proportional Band*, and away from the *Control Setpoint*, the Proportional component will increase. If the *Control Input* is in the middle of the *Proportional Band*, the Proportional component value is 50%, and when the *Control Input* reaches the outside of the *Proportional Band*, the Proportional value will be 100%. The value of the Proportional component is calculated as the difference between the *Control Input* and the *Control Setpoint*, divided by the *Proportional Band* and then multiplied by 100.

#### Example:

Control Input:	Return Air Temperature
Control Setpoint:	100° F
Dead Band:	0° F
Proportional Band:	10° F
Action:	Forward

Control Input	Proportional Output
100° F	0%
102.5° F	25%
105° F	50%
108° F	80%
110° F	100%
112° F	100%

The value selected for the *Proportional Band* will be determined by the stability of the system, the accuracy required, and the average output value, among other things. One way to pick a starting value is to find a range of allowable Control Input values and then to select a *Proportional Band* so that the Proportional value will reach 100% before the *Control Input* moves outside of the allowable range.

After the initial value is entered for the *Proportional Band*, watch the system to see how it reacts. If the PID output shows too much oscillation, increasing the Proportional Band will cause the control to react slower, which will dampen this oscillation. If the PID reacts too slowly, then decreasing the *Proportional Band* will make the control react faster.

**Proportional Only Control** - There will be certain applications in which only proportional control is required for good performance. When this is the case, the Integration Time can simply be set to zero, and the *Proportional Band* set to a desired value.

Some advantages of only using Proportional control are that it is generally more stable than Proportional and Integral control, and its function is easier to understand. A disadvantage of only using Proportional control is that the *Control Input* usually will settle into a spot somewhere in the *Proportional Band*, and will not move to the *Control Setpoint*. For instance, from the example shown above, if the *Proportional Output* averages 80%, then the *Control Input* will remain at 108° F and will not go to 100° F. This may be acceptable in some applications. In certain other cases the setpoint can be offset to move the *Control Input* to the point it needs to be.

**Integration Time** - The Integral calculation in PID control uses past performance to calculate a value for the PID output. It does this by periodically adding a small value to the PID output to move the *Control Input* toward the *Control Setpoint*. Eventually, the Integral component of the PID output will equal the average PID output value as *Control Input* gets to the *Control Setpoint*, and the Proportional component goes to 0%. When combined with the Integral calculation, the Proportional component can be negative and its range becomes -100% to +100%. If the *Control Input* moves above or below the *Control Setpoint*, the Proportional control will prevent it from moving too far, and the Integral control will move it back to the setpoint.

Once the *Proportional Gain* is set, start with a large Integration Time (180 seconds). Here again, you want to find the range of Integration Time that gives you reasonably fast performance, without too much overshoot, and without too much oscillation. If the *Control Input* repeatedly overshoots the *Control Setpoint*, or oscillates too much, increasing the *Integration Time* will slow the control. If the *Control Input* moves too slowly toward the *Control Setpoint*, decreasing the *Integration Time* will cause the control to react faster.

## SETPOINTS – Auxiliaries – Analog Inputs – Condenser (or Vessel) Safeties

10:00:41 Jun 29 2007		Condenser Auxiliary Analog Input Safeties					
	Warning Enable	Low Setpoint		High Setpoint		Delay	
Condenser Aux Analog 1	Enabled	20.0 %	30 SEC	80.0 %	30 SEC		
Condenser Aux Analog 2	Enabled	20.0 %	30 SEC	80.0 %	30 SEC		
Condenser Aux Analog 3	Enabled	20.0 %	30 SEC	80.0 %	30 SEC		
Condenser Aux Analog 4	Enabled	20.0 %	30 SEC	80.0 %	30 SEC		
Condenser Aux Analog 5	Enabled	20.0 %	30 SEC	80.0 %	30 SEC		
Condenser Aux Analog 6	Enabled	20.0 %	30 SEC	80.0 %	30 SEC		
Condenser Aux Analog 7	Enabled	20.0 %	30 SEC	80.0 %	30 SEC		
Condenser Aux Analog 8	Enabled	20.0 %	30 SEC	80.0 %	30 SEC		
Condenser Aux Analog 9	Enabled	20.0 %	30 SEC	80.0 %	30 SEC		
Condenser Aux Analog 10	Enabled	20.0 %	30 SEC	80.0 %	30 SEC		

**SCREEN NAME:** *Setpoints – Auxiliaries - Analog Inputs – Condenser (or Vessel) Safeties.*

**ACCESSING:**



**DESCRIPTION:** This screen allows the user to set the operating safeties of Analog Auxiliary Inputs 1 through 5.

This screen appears identically (except for the title), for both the Condenser and Vessel setup. Drop down menu boxes are provided for the following :

### Condenser (or Vessel) Auxiliary Analogs 1 through 10

- Disabled – The auxiliary channel will not be monitored for warnings or shutdowns.
- When Running - The auxiliary channel will be monitored for warning and shutdown occurrences only when the unit is Running.
- Always - The auxiliary channel will be monitored for warning and shutdown occurrences at all times (Running or not).

The following setpoints are provided for each Auxiliary Analog channel:

**[Low Setpoint]** – This setpoint specifies the *Warning* alarm threshold. In the event that the associated auxiliary analog input falls below this value for a

period of time exceeding the *Low Warning Delay*, an Auxiliary Low Warning Alarm will be issued.

**[Low Delay]** – This setpoint specifies the period of time that the associated auxiliary analog input must remain below the *Low Setpoint* before an Auxiliary Low Warning Alarm will be issued.

**[High Setpoint]** – This setpoint specifies the *High Shutdown* alarm threshold. In the event that the associated auxiliary analog input falls below this value for a period of time exceeding the *High Setpoint*, an Auxiliary Shutdown will be issued.

**[High Delay]** – This setpoint specifies the period of time that the associated auxiliary analog input must remain above the *High Setpoint* before an Auxiliary Shutdown will be issued.

**NOTE:** If you wish to bypass the warnings and utilize only the shutdown feature, then set all warning values outside of the shutdown values.

**SETPOINTS – Auxiliaries – Digital Input Configuration (Condenser or Vessel)**

10:32:19  
Jun 29 2007

Digital Input Configuration Condenser

Name	Device Source	I/O Channel	Activity	Delay
Auxiliary Input 1	None	0	Enabled	30 SEC
Auxiliary Input 2	None	0	Enabled	30 SEC
Auxiliary Input 3	None	0	Enabled	30 SEC
Auxiliary Input 4	None	0	Enabled	30 SEC
Auxiliary Input 5	None	0	Enabled	30 SEC
Auxiliary Input 6	None	0	Enabled	30 SEC
Auxiliary Input 7	None	0	Enabled	30 SEC
Auxiliary Input 8	None	0	Enabled	30 SEC

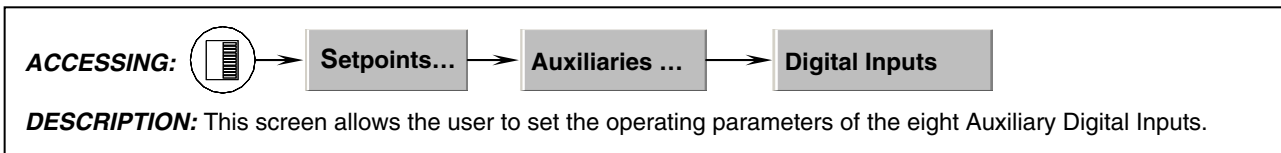

Use this screen to setup an Auxiliary Digital Input that is to be used to generate a warning or a shutdown whenever the associated input is not active (off). As an example from the screen shown above:

If Auxiliary Input 1 is set to *Shutdown When Running*, and the *Delay* is set to 10 seconds, then whenever the device that is physically attached to I/O Channel 15 (Digital Board 1) becomes inactive (turns off) AND the unit is *Running*, then the delay timer will start to count down. When the Delay times out, a shutdown message is issued (*Auxiliary Input 1 Shutdown*), and the unit will stop running.

A drop down menu box is provided for each of the eight possible Auxiliary Inputs:

**[Activity]**

- Enabled (when Condenser screen is selected)
- Disabled (Condenser and Vessel)
- Condenser (Condenser only)
- Vessel 1 (when Vessel screen is selected)
- Vessel 2 (when Vessel screen is selected)
- Vessel 3 (when Vessel screen is selected)

**[Delay]** - This value specifies the duration that the digital signal must remain off before a warning alarm is issued.

## SETPOINTS – Auxiliaries – Digital Output Configuration - Condenser

10:42:52  
Jun 29 2007

### Digital Output Configuration

#### Condenser

Output	Status	Analog Channel	On When	Off When	Enable
A	Off	Pressure	> 60.0 %	< 30.0 %	Enabled
B	Off	Outside Air Temperature	> 60.0 °F	< 30.0 °F	Enabled
C	Off	Outside Air Humidity	> 60.0 %	< 30.0 %	Enabled
D	Off	Drain Temperature	> 60.0 °F	< 30.0 °F	Enabled
E	Off	Condenser Aux Analog 1	> 60.0 %	< 30.0 %	Enabled
F	Off	Condenser Aux Analog 2	> 60.0 %	< 30.0 %	Enabled
G	Off	Condenser Aux Analog 3	> 60.0 %	< 30.0 %	Enabled
H	Off	Condenser Aux Analog 4	> 60.0 %	< 30.0 %	Enabled
I	Off	Condenser Aux Analog 5	> 60.0 %	< 30.0 %	Enabled
J	Off	Condenser Aux Analog 6	> 60.0 %	< 30.0 %	Enabled

Output	Device Source	I/O Channel
A	None	0
B	None	0
C	None	0
D	None	0
E	None	0
F	None	0
G	None	0
H	None	0
I	None	0
J	None	0

**ACCESSING:** **DESCRIPTION:** This screen allows the user to set the operating parameters of the Auxiliary Digital Outputs.

Use this screen to setup and control an Auxiliary Digital Output based upon the signal from an Analog Input. An example temperature control would resemble the following sine wave:

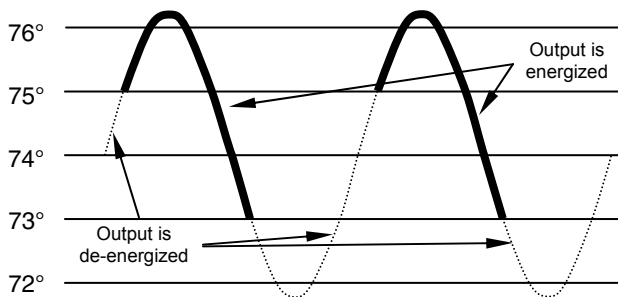

The bottom half of this screen shows the available Digital Outputs along with their Device Source and I/O Channels.

A drop down menu box is provided to select a channel to control from:

**[Analog Channel] –**

- Pressure
- Outside Air Temperature
- Outside Air Humidity
- Drain Temperature
- Condenser Aux Analog 1 – 10

**[On/Off When] –** When operating in the (>) mode, the digital output will be de-energized when the analog signal falls below the *Off When* value, and will remain off until the input rises above the *On When* value. Similarly, when operating in the (<) mode, the digital output will be de-energized when the input signal exceeds the *Off When* value and re-energized when the analog signal falls below *On When* value.

**[Enable] –**

- Disabled - The output will be disabled.
- Enabled - The output is controlled.

**SETPOINTS – Auxiliaries – Digital Output Configuration - Vessel**

10:45:21  
Jun 29 2007

**Digital Output Configuration**      **Vessel**

Output	Status	Analog Channel	On When	Off When	Enable
A	Off	Refrigerant Level	> 60.0 %	< 30.0 %	Vessel 1
B	Off	Pressure	> 60.0 PSIG	< 30.0 PSIG	Vessel 2
C	Off	Pump 1 High Side Pressure	> 60.0 PSIG	< 30.0 PSIG	Vessel 3
D	Off	Pump 1 Low Side Pressure	> 60.0 PSIG	< 30.0 PSIG	Vessel 1
E	Off	Pump 2 High Side Pressure	> 60.0 PSIG	< 30.0 PSIG	Vessel 2
F	Off	Pump 2 Low Side Pressure	> 60.0 PSIG	< 30.0 PSIG	Vessel 3
G	Off	Pump 3 High Side Pressure	> 60.0 PSIG	< 30.0 PSIG	Vessel 1
H	Off	Pump 3 Low Side Pressure	> 60.0 PSIG	< 30.0 PSIG	Vessel 2
I	Off	Pump 4 Motor Amps	> 60 AMPS	< 30 AMPS	Vessel 3
J	Off	Pump 2 Motor Amps	> 60 AMPS	< 30 AMPS	Vessel 1

Output	Device Source	I/O Channel
A	Digital Board4	16
B	Digital Board5	8
C	Digital Board5	24
D	Digital Board6	0
E	Digital Board6	0
F	Digital Board6	0
G	Digital Board6	0
H	Digital Board6	0
I	Digital Board6	0
J	Digital Board6	0

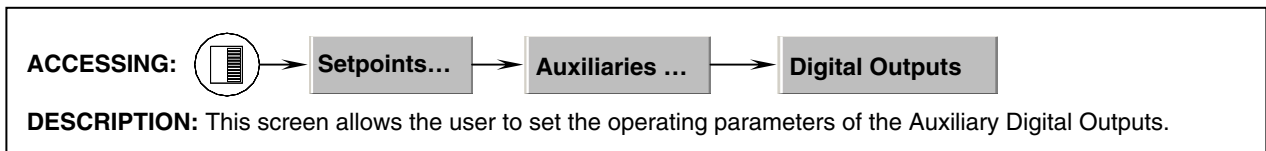

Use this screen to setup and control an Auxiliary Digital Output based upon the signal from an Analog Input. An example temperature control would resemble the following sine wave:

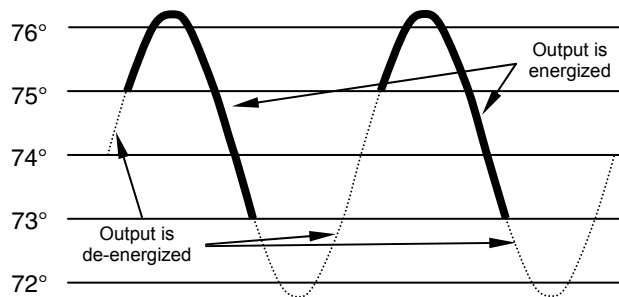

The bottom half of this screen shows the available Digital Outputs along with their Device Source and I/O Channels.

A drop down menu box is provided to select a channel to control from:

**[Analog Channel] –**

- Refrigerant Level
- Pressure
- Pump 1-4 High Side Pressure
- Pump 1-4 Low Side Pressure
- Pump 1-4 Motor Amps
- Vessel Aux Analog 1 – 10

**[On/Off When] –** When operating in the (>) mode, the digital output will be de-energized when the analog signal falls below the Off When value, and will remain off until the input rises above the On When value. Similarly, when operating in the (<) mode, the digital output will be de-energized when the input signal exceeds the Off When value and re-energized when the analog signal falls below On When value.

**[Enable] –**

- Disabled - The output will be disabled.
- Vessel 1 - The output is controlled by Vessel 1.
- Vessel 2 - The output is controlled by Vessel 2.
- Vessel 3 - The output is controlled by Vessel 3.

### SETPOINTS – Panel

Panel Temperature	27.2 °F	Date	
Panel Heater		Month	6
Status	On	Day	29
On	104.0 °F	Year	2007
Off	122.0 °F	Time	
		Hour	10
		Minutes	17

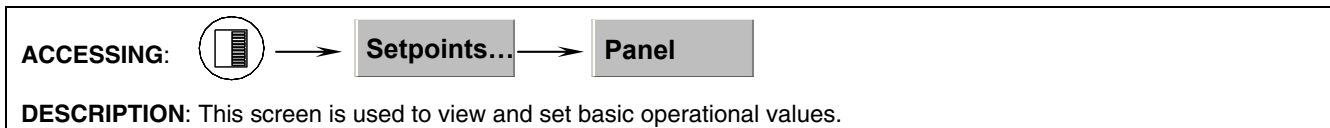

The following status display areas are provided:

**Panel Temperature** - The main processor board is equipped with a temperature sensor. The panel has an operational temperature range that is automatically maintained.

**Panel Heater** - A heating pad may be mounted in the panel to automatically maintain the internal temperature to allow the electronics to function properly. The following Status message and Setpoint boxes show the current state of the Panel Heater:

- **Off** - If the panel temperature is greater than or equal to this setpoint, the Panel Heater output is turned off.
- **On** - If the panel temperature is less than or equal to this setpoint, the Panel Heater output is turned on.

The following setpoint boxes are provided:

**Date** - Set the following setpoint boxes to the current date:

- [Month]** – Range is 1-12
- [Day]** – Range is 1-31
- [Year]** – Range is 2000-2050

**Time** - Set the following three setpoint boxes to the current time:

- [Hour]** – Range is 0-23
- [Minutes]** – Range is 0 to 59

**CALIBRATION – Condenser**

	Current Value	Offset	Low	Range	High	Sensor Signal
Pressure	71.8 PSIG	0.0 PSIG	30.0 Hg		185.3 PSIG	1-5V
Outside Air Temperature	453.0 °F	0.0 °F				ICTD
Outside Air Humidity	2.4 %	0.0 %	0.0 %		100.0 %	4-20mA
Drain Temperature	32.0 °F	0.0 °F				ICTD

**ACCESSING:**  → **Calibration...** → **Condenser**

**DESCRIPTION:** This screen is used to calibrate the Pressure, Outside Air Temperature, Outside Air Humidity and Strain Temperature sensors.

This screen should be used anytime a sensor is found to be out of calibration. The recommended practice for adjusting the calibration reading is to first determine which sensor(s) need to be calibrated. Once this is determined, you must know the actual reading that the sensor should be showing. This can be accomplished by comparing the displayed reading shown here, with the actual value using a separate measurement device, such as a Digital Volt Meter, or temperature probe, etc. Determine the difference between what the screen reading for the sensor is, and what the reading of the separate device shows. As an example, assume that the Humidity on this screen reads 30%, but a separate device is showing a reading of 40%. Highlight the setpoint box for Humidity, and enter the value of 30. The new reading will now read 30, and should match your separate reading.

A setpoint box exists for each of the displayed analog readings:

**[Pressure]**

- Current Value

- Offset
- Low Range
- High Range

**[Outside Air Temperature]**

- Current Value
- Offset

**[Outside Air Humidity]**

- Current Value
- Offset
- Low Range
- High Range

**[Drain Temperature]**

- Current Value
- Offset

### CALIBRATION – Vessel 1-3

Frick		Jun 29 2007	11:12:59	Calibration - Vessel 1		
	Current Value	Offset	Low Range	High Range	Sensor Signal	
Refrigerant Level	59.9 %	0.0 %	0.0 %	100.0 %	4-20mA	
Pressure	285.3 PSIG	0.0 PSIG	30.0 Hg	285.3 PSIG	1-5V	
Pump 1 Motor Amps	0 AMPS	0 AMPS	0 AMPS	100 AMPS	CT	
Pump 2 Motor Amps	0 AMPS	0 AMPS	0 AMPS	100 AMPS	CT	
Pump 3 Motor Amps	0 AMPS	0 AMPS	0 AMPS	100 AMPS	CT	
Pump 4 Motor Amps	0 AMPS	0 AMPS	0 AMPS	100 AMPS	CT	
Pump 1 High Side Pressure	30.0 Hg	0.0 PSIG	30.0 Hg	285.3 PSIG	1-5V	
Pump 2 High Side Pressure	30.0 Hg	0.0 PSIG	30.0 Hg	285.3 PSIG	1-5V	
Pump 3 High Side Pressure	30.0 Hg	0.0 PSIG	30.0 Hg	285.3 PSIG	1-5V	
Pump 4 High Side Pressure	30.0 Hg	0.0 PSIG	30.0 Hg	285.3 PSIG	1-5V	
Pump 1 Low Side Pressure	30.0 Hg	0.0 PSIG	30.0 Hg	285.3 PSIG	1-5V	
Pump 2 Low Side Pressure	30.0 Hg	0.0 PSIG	30.0 Hg	285.3 PSIG	1-5V	
Pump 3 Low Side Pressure	30.0 Hg	0.0 PSIG	30.0 Hg	285.3 PSIG	1-5V	
Pump 4 Low Side Pressure	30.0 Hg	0.0 PSIG	30.0 Hg	285.3 PSIG	1-5V	

**ACCESSING:** → **Calibration...** → **Analog Inputs**

**DESCRIPTION:** This screen is used to calibrate the various sensors.

This screen should be used anytime a sensor is found to be out of calibration. The recommended practice for adjusting the calibration reading is to first determine which sensor(s) need to be calibrated. Once this is determined, you must know the actual reading that the sensor should be showing. This can be accomplished by comparing the displayed reading shown here, with the actual value using a separate measurement device, such as a Digital Volt Meter, or temperature probe, etc. Determine the difference between what the screen reading for the sensor is, and what the reading of the separate device shows. As an example, assume that the Pressure on this screen reads 285.3 PSIG, but a separate device is showing a reading of 290.3%. Highlight the offset box for Pressure, and enter the value of 5.0 (the difference between 285.3 and 290.0). The new reading will now read 290.0, and should match your separate reading.

A setpoint box exists for each of the displayed analog readings:

**[Refrigerant Level]**

- Current Value
- Offset
- Low Range
- High Range

**[Pressure]**

- Current Value
- Offset
- Low Range
- High Range

**[Pump 1-4 Motor Amps]**

- Current Value
- Offset
- Low Range
- High Range

**[Pump 1-4 High Side Pressure]**

- Current Value
- Offset
- Low Range
- High Range

**[Pump 1-4 Low Side Pressure]**

- Current Value
- Offset
- Low Range
- High Range

**CALIBRATION – ANALOG OUTPUTS – *Condenser Outputs***

	Device Source	Device Channel
Variable Speed Fan 1	Analog Board1	1
Variable Speed Fan 2	Analog Board1	2
Variable Speed Fan 3	Analog Board1	3
Variable Speed Fan 4	Analog Board1	4
Variable Speed Fan 5	Analog Board1	5
Variable Speed Fan 6	Analog Board1	6
Variable Speed Fan 7	Analog Board1	7
Variable Speed Fan 8	Analog Board1	8

**ACCESSING:**  → Calibration... → Analog Outputs... → Condenser Outputs

**DESCRIPTION:** Use this screen to assign specific device channels to a particular analog board.

**CALIBRATION – ANALOG OUTPUTS – *Vessel Outputs***

	Device Source	Device Channel
Modulating Valve - Vessel 1	Analog Board2	1
Modulating Valve - Vessel 2	Analog Board2	2
Modulating Valve - Vessel 3	Analog Board2	3

**ACCESSING:**  → Calibration... → Analog Outputs... → Vessel Outputs

**DESCRIPTION:** Use this screen to assign specific device channels to a particular analog board.

## CALIBRATION – ANALOG OUTPUTS – *Analog Output Calibration*

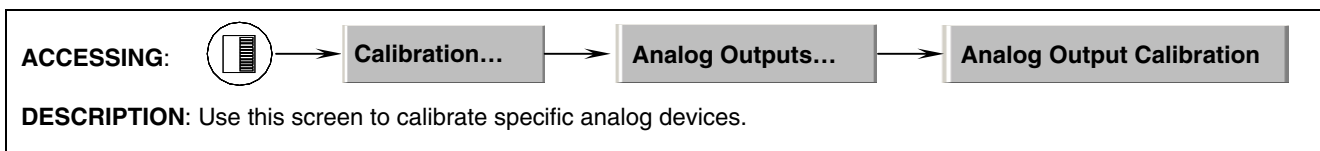

The Quantum™ LX analog outputs have a range of approximately zero to 25mA, but most devices that are controlled require a signal that varies between 4 and 20mA. To restrict the analog outputs to the proper values, each of the outputs must be calibrated before they can be used. Every output channel has a *Top End* and a *Bottom End* value that are used for calibration. Both values can be set from 0% to 100%. The output channel's maximum value is represented by 100% and its minimum value is represented by 0%. To calibrate the channel, the *Top End* percentage is decreased until the maximum output for the channel is limited to 20mA. In addition, the *Bottom End* percentage is increased until the minimum output for the channel is 4mA.

Below is a systematic procedure for calibrating one analog output.

1. Configure the analog output channel for its intended use. For example, if the channel is to be used for PID control, enter the Device Source and Device Channel of the selected analog output channel under one of the PID columns on the PID Setup page.
2. Set a meter to read the channel output value in milliamps.
3. Select the Analog Board and the Channel Number for the output that is being calibrated.

4. After the Analog Board and Channel Number are selected, the channel function will be displayed below the Channel Number. If *Not Configured* is shown here instead, the channel has not yet been assigned a control function. Return to step 1 and setup the channel for the control task it is to perform.
5. Press **[1]** and the value shown on the meter should go to the channel low-end value.
6. Check that the "Delta For Changing Output Percentage" value is 10.00. If it is not, press **[0]** until it is displayed as 10.00.
7. If the channel output is greater than 4mA press **[4]**. If the channel output is less than 4mA, press **[7]**. Use these keys to find the output value closest to 4mA.
8. Press **[0]** once to decrease the "Delta For Changing Output Percentage" value to 1.00.
9. Use the **[7]** and **[4]** buttons again to find the value closest to 4mA.
10. Repeat steps 9 and 10 for Delta values of 0.1 and 0.01 to bring the output value as close as possible to 4mA.
11. Press **[3]** and the value shown on the meter should go to the channel high-end value.

12. Check that the “Delta For Changing Output Percentage” value is 10.00. If it is not, press [0] until it is displayed as 10.00.
13. If the channel output is greater than 20mA press [4]. If the channel output is less than 20mA, press [7]. Use these keys to find the output value closest to 20mA.
14. Press [0] once to decrease the “Delta For Changing Output Percentage” value to 1.00.

15. Use the [7] and [4] buttons to again find the value closest to 20mA.
16. Repeat steps 15 and 16 for Delta values of 0.1 and 0.01 to bring the output value as close as possible to 20mA.

**NOTE:** The analog output channel will return to its control task either when another output channel is selected for calibration or when the user goes to another screen.

**CALIBRATION – Condenser (or Vessel) Auxiliaries – Page 1**

Name	Current Value	Offset	Range Low	Range High
Condenser Aux Analog 1	-10.9 %	0.0 %	0.0 %	100.0 %
Condenser Aux Analog 2	-14.9 %	0.0 %	0.0 %	100.0 %
Condenser Aux Analog 3	-17.3 %	0.0 %	0.0 %	100.0 %
Condenser Aux Analog 4	33.1 %	0.0 %	0.0 %	100.0 %
Condenser Aux Analog 5	-17.4 %	0.0 %	0.0 %	100.0 %
Condenser Aux Analog 6	-12.2 %	0.0 %	0.0 %	100.0 %
Condenser Aux Analog 7	25.8 %	0.0 %	0.0 %	100.0 %
Condenser Aux Analog 8	8.8 %	0.0 %	0.0 %	100.0 %
Condenser Aux Analog 9	14.1 %	0.0 %	0.0 %	100.0 %
Condenser Aux Analog 10	27.4 %	0.0 %	0.0 %	100.0 %

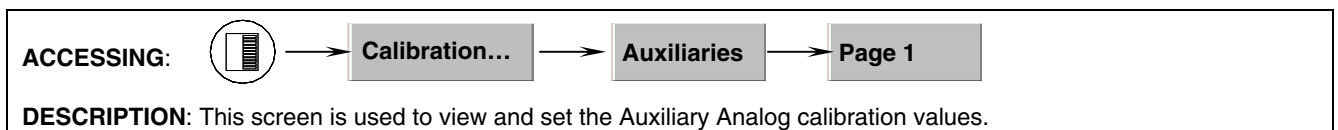

This screen can be used to custom name each of the Auxiliary Analog channels as well as performing calibration. To change a name, simply click on the box that contains the name (at the left side of the screen), and type a new name into the box (refer to the section entitled **MISCELLANEOUS SCREENS - Alpha**), then click [Submit].

At the top of this screen is a setpoint entry box, where a particular zone number can be entered. When a different zone number is entered and submitted, the screen data will be updated with the information from that zone.

A dropdown menu box exists for each of the displayed auxiliary readings.

- Current Value
- Offset
- Range
  - Low
  - High

**CALIBRATION – Condenser (or Vessel) Auxiliaries – Page 2**

Frick		Jun 29 2007	12:16:15	Calibration - Condenser Auxiliaries		Page 2
Name	Device Source	IO Channel	Sensor Signal	Sensor Type	Units If Type Is Other	
Condenser Aux Analog 1	Analog Board1	4	4-20mA	None		
Condenser Aux Analog 2	Analog Board1	5	4-20mA	None		
Condenser Aux Analog 3	Analog Board1	6	4-20mA	None		
Condenser Aux Analog 4	Analog Board1	7	4-20mA	None		
Condenser Aux Analog 5	Analog Board1	8	4-20mA	None		
Condenser Aux Analog 6	Analog Board1	9	4-20mA	None		
Condenser Aux Analog 7	Analog Board1	10	4-20mA	None		
Condenser Aux Analog 8	Analog Board1	11	4-20mA	None		
Condenser Aux Analog 9	Analog Board1	12	4-20mA	None		
Condenser Aux Analog 10	Analog Board1	13	4-20mA	None		

**ACCESSING:** → Calibration... → Auxiliaries → Page 2

**DESCRIPTION:** This screen is used to view and set the Auxiliary Analog calibration values.

This screen will show any custom named auxiliaries from Page 1 at the left side of the screen. Use this screen to set the Sensor Signal, Sensor Type, and to change the units if set to *Other*.

A dropdown menu box exists for each of the displayed auxiliary readings:

- Sensor Signal
    - None
    - 0-5V
    - 1-5V
    - 4-20mA
    - Pot. (Potentiometer)
    - ICTD
    - RTD
    - CT
  - Sensor Type
    - None
    - Pressure
    - Temperature
    - Other
  - RPM
  - Vibration
  - 0-10V
  - +/-5V
  - 2-10V
- Units if Type is Other - Up to 5 characters may be entered here. To enter alpha-numeric values in this column, refer to the section entitled **MISCELLANEOUS SCREENS - Alpha**.

**CONFIGURATION – Panel Configuration**

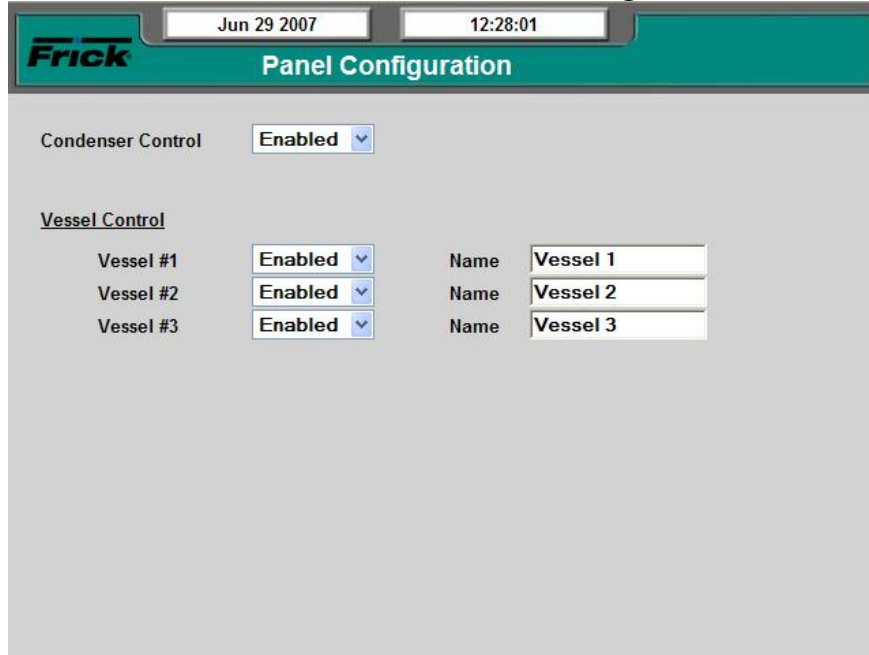

**ACCESSING:**  → **Configuration...** → **Panel Configuration**

**DESCRIPTION:** This screen is used to custom name each configured Vessel, and to enable or disable them. It also allows for enabling or disabling the Condenser control.

This screen will show all the Condenser Control as well as the three potential Vessels.

To custom name any of the installed Vessels, simply select the box next to the Name that you wish to customize, and enter the custom name (refer to the section entitled **MISCELLANEOUS SCREENS - Alpha**).

A dropdown menu box exists to enable or disable each Vessel, as well as Condenser Control:

- **Disabled**
- **Enabled**

## CONFIGURATION – Condenser Step Configuration

Step	Name	Type	Aux. Failure	Outside Air Stop	Hi - Lo Delay	Analog Output
1	Single Speed Fan #1	Single Speed Fan	Enabled			
2	Two Speed Fan Lo #2	Two Speed Fan Lo	Enabled		15 SEC	
3	Two Speed Fan Lo #3	Two Speed Fan Hi	Enabled			
4	Var Speed Fan #4	Var Speed Fan	Enabled			A
5	Water Pump #5	Water Pump	Enabled	Enabled		
6	Two Speed Fan Hi #6	Disabled	Enabled			
7	Two Speed Fan Lo #7	Disabled	Disabled			
8	Two Speed Fan Hi #8	Disabled	Disabled			
9	Single Speed Fan #9	Disabled	Disabled			
10	Step #10	Disabled	Enabled			
11	Step #11	Disabled	Disabled			
12	Single Speed Fan #12	Disabled	Disabled			
13	Single Speed Fan #13	Disabled	Disabled			
14	Water Pump #14	Disabled	Disabled			
15	Water Pump #15	Disabled	Disabled			
16	Single Speed Fan #16	Disabled	Disabled			
17	Water Pump #17	Disabled	Disabled			
18	Water Pump #18	Disabled	Disabled			
19	Two Speed Fan Lo #19	Disabled	Disabled			
20	Two Speed Fan Hi #20	Disabled	Disabled			
21	Two Speed Fan Lo #21	Disabled	Disabled			
22	Two Speed Fan Hi #22	Disabled	Disabled			
23	Two Speed Fan Lo #23	Disabled	Disabled			
24	Two Speed Fan Hi #24	Disabled	Disabled			

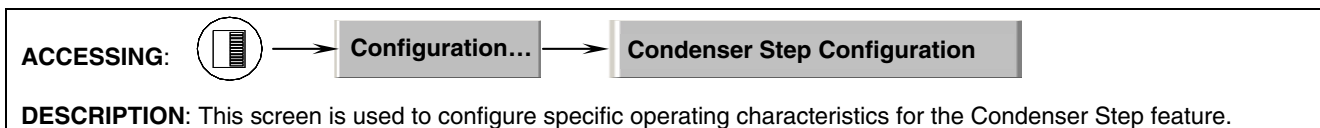



The following setpoint box appears on this screen:

**Name** – Enter a custom name that you wish the particular Step to be known as. To custom name any of the installed zones, refer to the section entitled **MISCELLANEOUS SCREENS - Alpha**.

- 
- **Type**
  - Disabled
  - Single Speed Fan
  - Two Speed Fan Lo
  - Two Speed Fan Hi
  - Var. Speed Fan
  - Water Pump
- **Aux. Failure**
  - Disabled
  - Enabled
- **Outside Air Stop** (only appears based upon certain configuration setups)
  - Disabled
  - Enabled
- **Hi – Lo Delay** (only appears based upon certain configuration setups)
- **Analog Output** (only appears based upon certain configuration setups)
  - A
  - B
  - C
  - D
  - E
  - F
  - H

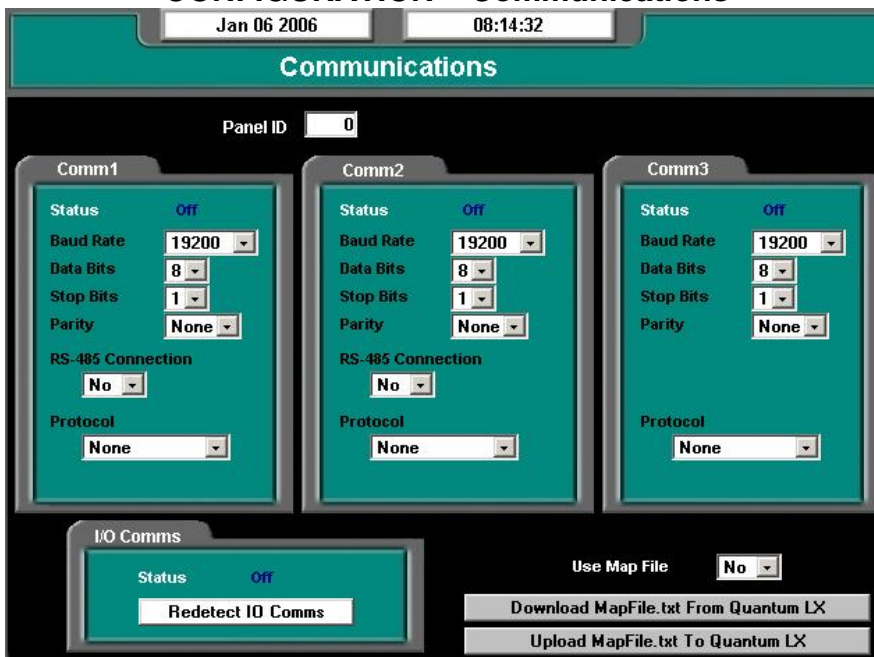
**CONFIGURATION – Communications**



**ACCESSING:**  → **Setpoints...** → **Communications**

**DESCRIPTION:** This screen is used to set the Quantum™ LX ID number, and the parameters for each of the three communications channels, as well as to show the status of the internal I/O board status.

The following setpoints are provided:

**[Panel ID]** - The value of the Quantum™ LX Control Panel. On networked systems, this number must be unique. Valid values are from 0 - 99.

Comm1

(Setup parameter definitions for Comm1 and 2 are identical) Communications related information for the communications ports:

**Status** - Shows the current communications status of the port. The possible messages are:

- **Off** - No communications are currently taking place. NOTE: A delay of 15 seconds or more of inactive communications (time between valid responses) will cause this message to display.
- **Active** - Valid communications are actively occurring.
- **Failed** - An invalid command was received by the port. This could be due to a bad checksum value, a wiring issue, or hardware problem at either the transmitting (client) or receiving (Quantum™ LX) end.

**[Baud Rate]** - The baud rate defines the speed at which external communications can occur. The higher the baud rate, the faster the communications. The faster the baud rate, the more susceptible to external EMF. It is best to start out using a lower baud rate, and increasing the value only after verifying that communications errors do not occur. If errors start to occur, decrease the baud rate. A drop down menu is provided to select from the following:

- 1200
- 2400
- 4800
- 9600
- 19200
- 38400
- 57600
- 115200

**[Data Bits]** - Determines the number of bits in a transmitted data package. A pull down menu is provided to select from the following:

- 7
- 8

**[Stop Bits]** - A bit(s) which signals the end of a transmission on a serial line. A drop down menu is provided to select from the following:

- 1
- 2

**[Parity]** - In communications, parity checking refers to the use of *parity bits* to check that data has been transmitted accurately. The parity bit is added to every data unit (typically seven or eight data bits) that are transmitted. The parity bit for each unit is set so that all bytes have either an odd number or an even number of set bits. Parity checking is the most basic form of error detection in communications. A drop down menu is provided to select from the following:

- None
- Even
- Odd

**[RS-485 Communications]** - (Available for Comms1 and Comms 2 only). This pull down box allows the user to select whether or not the communications will be through RS-485 hardware protocol or not. A drop down menu is provided to select from the following:

- Yes
- No

**[Protocol]** - A protocol is the special set of rules that each end of a communications connection use when they communicate. A drop down menu is provided to select from the following Frick recognized protocols:

- None
- Frick
- ModBus ASCII
- ModBus RTU
- AB DF1 Full Duplex
- AB DF1 Half Duplex

**[I/O Comms]** - A status indicator is provided to show the current state of the internal communications of the I/O boards. The possible displayed states are:

- **Off** - Loss of communications or intermittent communications failures to the internal Quantum™ LX I/O boards.
- **Active** - Indicates that normal I/O communications are occurring.

- **Failed** - Loss of communications, a shutdown message will be generated.

**[Redetect IO Comms]** - Select this key to detect all connected Analog and Digital boards. If a board has been removed, a communication error shutdown will be issued until this key is selected. Reference the **About** screen to view what has been detected.

**[Use Map File]** - Because the addressing scheme between earlier Quantum™ version software and the Quantum™ LX version 3.0x and later software is not the same, this utility was created. The map file is a conversion utility that can be used to allow a communications application that was previously written by the user under the Quantum™ version 2.3x and earlier to function properly with the LX by redirecting the old addresses to the new LX addresses. A pull down menu is provided to select from the following:

- **No** - Do not use map file, the user is either not going to be using external communications, or they will be writing the communication application based upon the LX addresses.
- **Yes** - The user has an application that was previously written for the Quantum™ version 2.3x or earlier, and they want to utilize the same code for the LX.

Two keys are located at the bottom right hand side of the screen. The following describes their function:

**[Download MapFile.txt from Quantum™ LX]** – With a USB memory stick installed on the LX, pressing this key will cause the MapFile.txt file to be downloaded from the Quantum™ LX into the USB memory.

**[Upload MapFile.txt to Quantum™ LX]** – After the user has modified the MapFile.txt file to suit their needs, pressing this key will cause the file to be uploaded from the USB memory back into the Quantum™ LX.

**CONFIGURATION – Ethernet**

**ACCESSING:** **Configuration** → **Ethernet**

**DESCRIPTION:** This screen is used to view and set basic Ethernet operational values. It is from this screen that all internet and e-mail based operating characteristics are set. **NOTE:** In order to connect to the Internet, a valid Internet account and connection must be used.

**NOTE:** User Level 1 or above must be set to access this screen.

The following fields are provided:

**IP Data:**

**[Address Type]** - The following drop down menu is provided:

- Fixed (Static)
- DHCP (Dynamic)

This should be set by the network or LAN administrator.

**[IP Address]** - Four setpoint boxes are provided here. The network or LAN administrator will enter the numerical IP address for this specific panel.

**[Gateway Address]** - Four setpoint boxes are provided here. The network or LAN administrator will enter the numerical Gateway address.

**[Subnet Mask]** – Like IP addresses, a subnet mask contains four bytes (32 bits) and is often written using the same "dotted-decimal" notation. A subnet mask neither works like an IP address, nor does it exist independently from them. Instead, subnet masks accompany an IP address and the two values work together.

Applying the subnet mask to an IP address splits the address into two parts, an "extended network address" and a host address.

For a subnet mask to be valid, its leftmost bits must be set to '1'. Conversely, the rightmost bits in a valid subnet mask must be set to '0', not '1'.

All valid subnet masks contain two parts: the left side with all mask bits set to '1' (the extended network portion) and the right side with all bits set to '0' (the host portion).

**[Web Server Port]** - One setpoint box is provided here. The network or LAN administrator will enter the numerical address for this Web port.

**Email Data**

**[Email Notification On Alarm or Shutdown]** - For the E-mail notification feature to work, it must be enabled (it is disabled as a default). The following drop down menu is provided:

- Disabled
- Enabled

**[Local Email Address]** - Use this setpoint box to enter a valid E-mail address.

**[Alias Name For Local Email Address]** - Enter here a custom name to identify more clearly the local Email address. When a message is sent to all recipients, this is the name that will appear in the Email *FROM* column.

**[Subject]** - Enter here a custom subject that you would like to have appear when a message failure is sent. When a message is sent to all recipients, this is the wording that will appear in the Email *SUBJECT* column.

**[SMTP Server Name OR IP Address]** - SMTP stands for **S**imple **M**ail **T**ransfer **P**rotocol. This

should be set by the network or LAN administrator.

**[SMTP Server Port Number]** - This value is in almost all cases going to be 25. This should be set by the network or LAN administrator.

**[Comma-Delimited List of Email Recipients]** - This is simply the list of the Email addresses that you would like to have any messages sent to.

**Refer to the Communications Manual (S90-560 CS) for additional information.**

### CONFIGURATION – Security

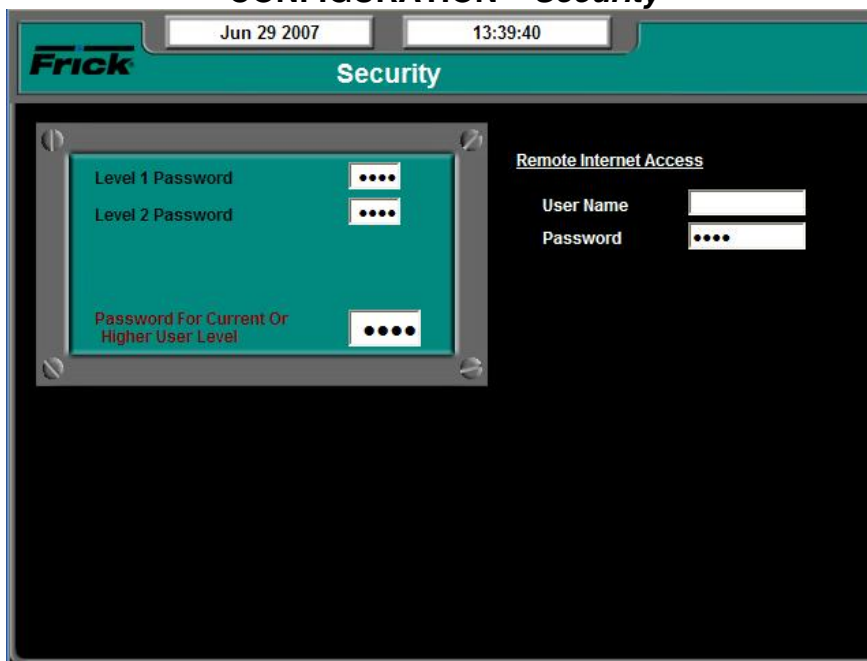

**ACCESSING:** 

**DESCRIPTION:** This screen allows the user/supervisor to set the various levels of password protection. The Security screen shown above can only be modified at the Quantum™ LX control panel via the keypad.

The various levels are:

- **Level 0** - Also known as the BASIC level. This level is not shown on the Security screen, as it is the lowest level of system access, and as such, does not require a password to activate. This is the default level, and provides access to only the very basics of machine operation.
- **Level 1** - Also known as the ADVANCED level. This requires a password to set. Only those users who are authorized with the password may enter this level. It provides greater access than Level 0 (BASIC). The valid entry range is zero (0) to 5000. The factory default value for this password is 10 (ten).

- **Level 2** - Also known as the SERVICE level. This requires a password to set. Only those users who are authorized with the password may enter this level. It provides greater access than Level 1. The factory default value for this password is 20.

To set the password protection for the each level, use the keypad to highlight the box beside the level that you wish to change. Set the level to either zero (0) or one (1), and enter the appropriate password for that level in the next box. The valid range for password entry is -999999 to 999999.

**NOTE:** It is highly recommended that the supervisor documents this password and stores it in a safe place. If the password is ever forgotten, it can only be corrected by calling the factory.

**SESSION**

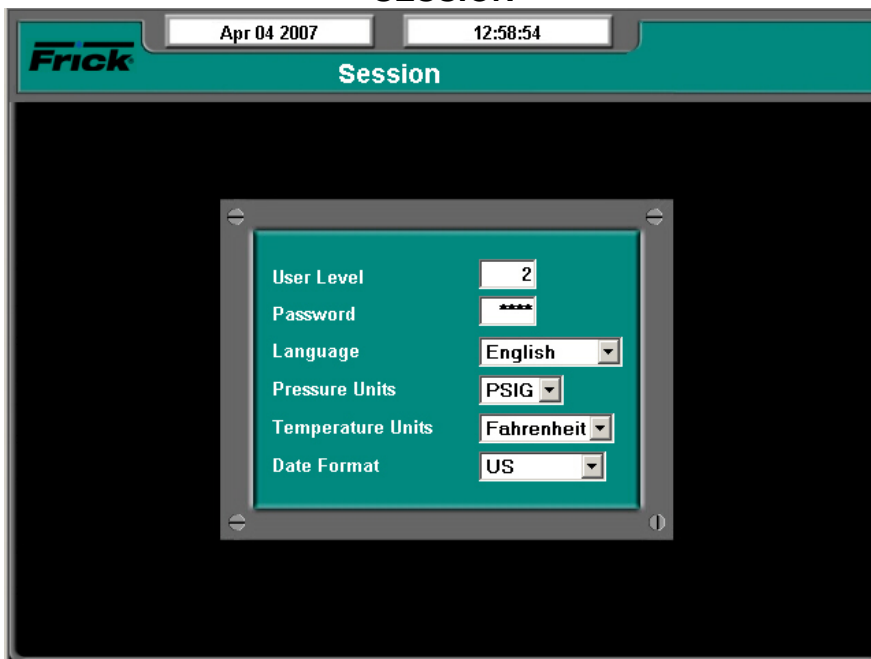

**ACCESSING:**  **Session**

**DESCRIPTION:** This screen allows the user/supervisor to access the various available user levels. This is also where the user can select the language, pressure units, temperature units and date format.

The following Setpoints may be changed:

**[User Level]** - Any one of three possible levels may be accessed here. Level one (0) is also referred to as the BASIC level, and requires no password. Level one (1) is referred to as ADVANCED, and requires a password. Level one (2) is referred to as SERVICE, and requires a password.

**[Password]** - A password has previously been assigned to each user level by the supervisor. The user must match the password for the particular level that they wish to access. The following factory default passwords have been provided:

- **Level 0** (Basic) – No password required
- **Level 1** (Advanced) – 10
- **Level 2** (Service) - 20

The following drop down menus have been provided:

**Language** - You may choose from the following list:

- English

**[Pressure Units]** - You may choose from the following list:

- Kpa
- Bar
- BarA
- PSIA
- PSIG/hg

**[Temperature Units]** - You may choose from the following list:

- Celsius
- Fahrenheit

**[Date Format]** - You may choose from the following list:

- **US** - Month/Day/Year format
- **Europe** - Day/Month/Year format

### SERVICE - Digital

Digital I/O

Board 1 Channels			
1	Off	13	Off
2	Off	14	Off
3	Off	15	Off
4	Off	16	Off
5	Off	17	Off
6	Off	18	Off
7	Off	19	Off
8	Off	20	Off
9	Off	21	Off
10	Off	22	Off
11	Off	23	On
12	Off	24	Off

Board 4 Channels			
1	Off	13	Off
2	Off	14	On
3	Off	15	Off
4	Off	16	Off
5	Off	17	Off
6	Off	18	Off
7	Off	19	Off
8	Off	20	Off
9	Off	21	Off
10	Off	22	Off
11	Off	23	Off
12	Off	24	Off

**ACCESSING:**  → **Service...** → **Digital**

**DESCRIPTION:** The service technician may use this screen to view the status of all digital I/O. This is an informational screen only.

### SERVICE - Analog

Analog Inputs (data units are Volts DC)

Board 1 Channels				Board 2 Channels			
1	2.73	13	2.10	1	3.40	13	0.00
2	4.95	14	0.05	2	1.74	14	0.00
3	1.10	15	0.08	3	1.03	15	0.00
4	0.56	16	0.00	4	5.00	16	0.00
5	0.40	17	0.87	5	0.00	17	0.00
6	0.31	18	5.00	6	0.00	18	0.00
7	2.32	19	5.00	7	0.00	19	0.00
8	0.30	20	4.02	8	0.00	20	0.00
9	0.51	21	0.01	9	0.00	21	0.00
10	2.03	22	5.00	10	0.00	22	0.00
11	1.35	23	4.58	11	0.00	23	0.00
12	1.56	24	5.00	12	0.00	24	0.00

Analog Outputs (data units are Volts DC)

Board 1 Channels				Board 2 Channels			
1	0.00	5	1.00	1	1.00	5	1.00
2	1.00	6	1.00	2	1.00	6	1.00
3	1.00	7	1.00	3	1.00	7	5.00
4	1.00	8	1.00	4	5.00	8	0.00

**ACCESSING:**  → **Service...** → **Analog**

**DESCRIPTION:** The service technician may use this screen to view the status of all analog I/O. This is an informational screen only.

**SERVICE – Communications Log**



**ACCESSING:**  → **Service...** → **Communications Log**

**DESCRIPTION:** The service technician may use this screen to view the status of all external communications.

The following user selectable buttons are provided:

- **[Show Comm1]**
- **[Show Comm2]**
- **[Show Comm3]**
- **[Show Comm4]**

This screen allows the technician to view all of the communications information that the Quantum™ LX is receiving and transmitting, one port at a time. Simply select the button at the upper right side of the screen that corresponds to the port that you wish to view. The

selected port name (in this case Comm4) will appear in the upper left side of the screen.

Each time a new command is sent or received, the screen will need to be refreshed by selecting the **[Show CommX]** button (where X is replaced with the comm port number).

This screen will display all data that is coming through the selected Communications (Comm) port. The top line of data is the most recent activity. At the left of each line, you should see whether the data is *IN* or *OUT* (Receive or Send), and the actual data (in Hexadecimal format). This information can be used to compare against the data being sent and received at the other end of the communications link, to verify proper operation.

### SERVICE – *Communications Loop Back Test*

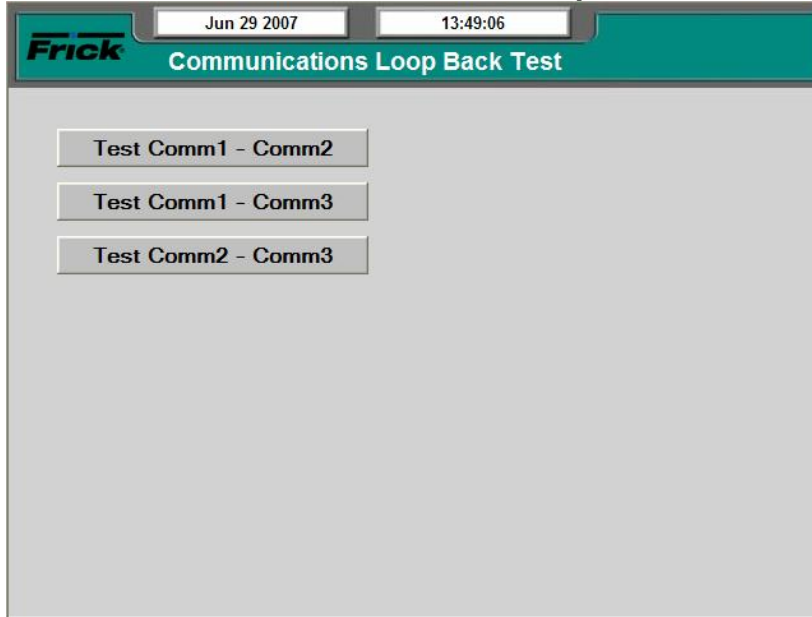

**ACCESSING:**  → Service... → Communications Loop Back Test

**DESCRIPTION:** The service technician may use this screen to test each of the external communications channels using a loopback cable.

Refer to the Communications Manual (S90-560 CS) for specific information about this test.

### SERVICE – *Diagnostics*

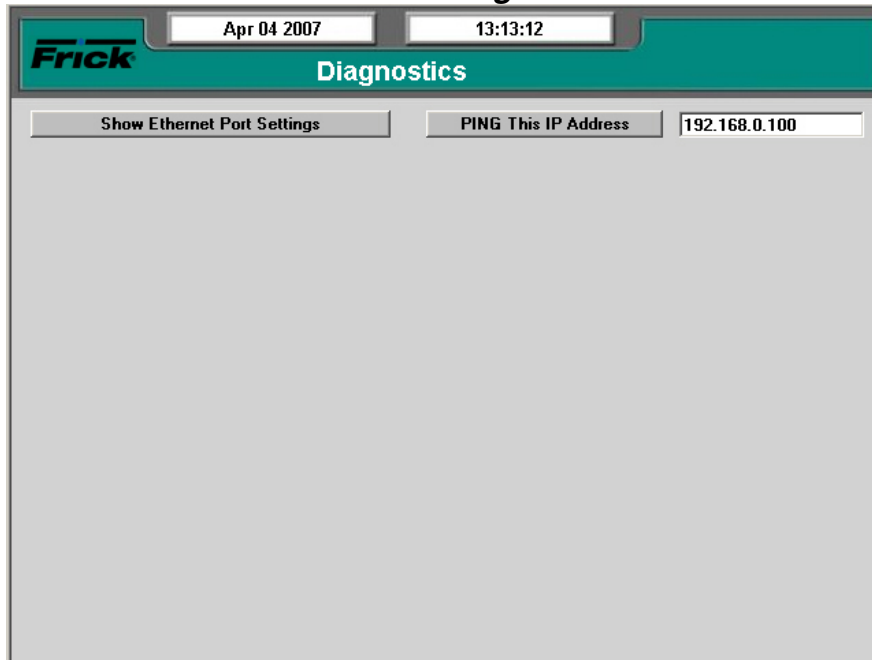

**ACCESSING:**  → Service... → Diagnostics

**DESCRIPTION:** The service technician may use this screen to test the Ethernet connection (if available).

**SERVICE – Software Maintenance**

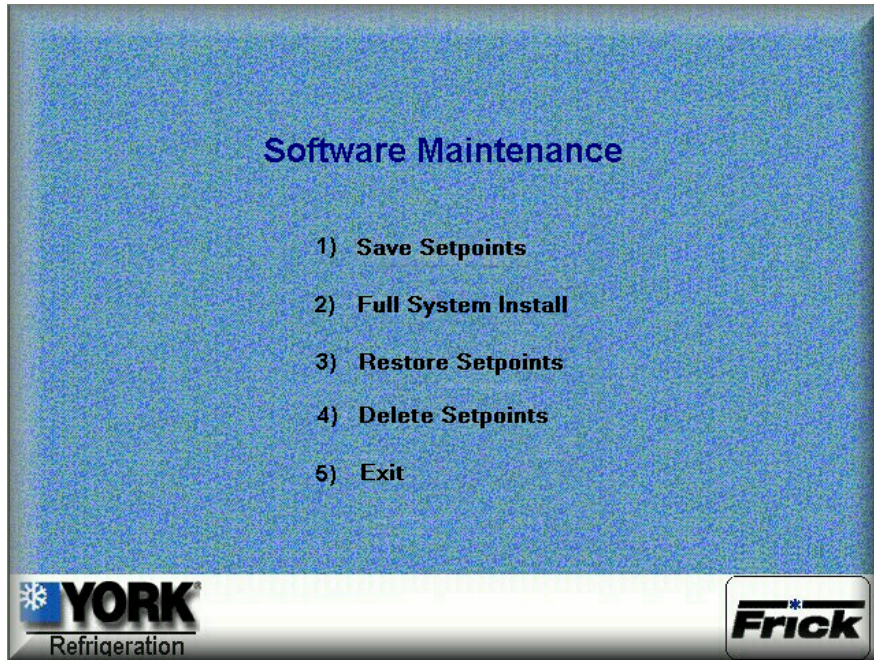

**ACCESSING:**  → **Service...** → **Software Maintenance**

**DESCRIPTION:** This screen allows the technician to perform system software maintenance.

The following selections have been provided:

- 1) **Save Setpoints** - Use this option to save all setpoints and custom text to a USB device as a form of backup:
  - Ensure that all setpoint values have been documented as a safety precaution Install a USB device into the provide connection on the Quantum™.
  - Press the [1] button.
  - The software program will read the USB device, and the following dialog box will appear:

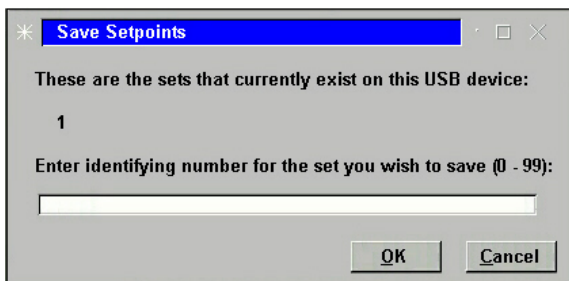

- Any numerals that appear on the center line of this box, will represent units that have already been saved (from 0 to 99). If no units have yet been saved, the center line will be blank.
- Enter a number on the keypad that corresponds to the unit number that you wish

to save, then press **[Enter]**. If the unit number has not been saved before, the setpoints will be saved to a file on the USB device (a progress bar will appear asking you to *Please Wait...* In the future, any time you try to write the setpoints to this number, you will be prompted with a message telling you that *the set number already exists – do you wish to overwrite it?* Answer by highlighting the Yes button, and pressing **[Enter]** if you do indeed wish to overwrite the values. If you enter a number that does not appear on the center line, no such warning will appear.

- After the file has been written or updated, the dialog boxes will disappear, and you can either exit, or continue with another function.

- 2) **Full System Install** - Use this option to install the program. This function will not overwrite any setpoints or custom text that may have previously been setup:
  - Ensure that all setpoint values have been documented as a safety precaution.
  - Press the [2] button.
  - If a valid USB device with the operating system loaded on it is plugged in, the software will be loaded. If however, there is no USB device installed, or the device does not contain the operating software, the following dialog box will appear:

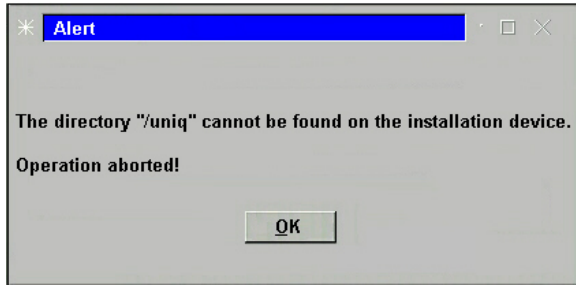

- If the above dialog box appears, you must insert a valid software upgrade USB device.

**3) Restore Setpoints** – Use this option to re-load previously saved setpoints and custom text to the Quantum™.

- Ensure that all setpoint values have been documented as a safety precaution. Install the previously saved setpoint USB device into the provided connection on the Quantum™.
- Press the [3] button.
- The software program will read the USB device, and the following dialog box will appear:

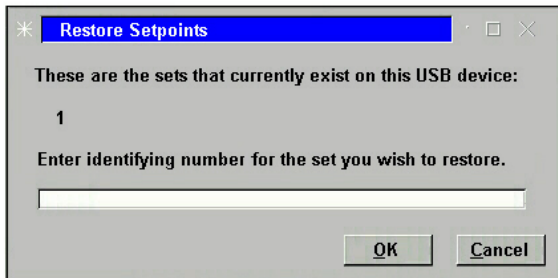

- Any numerals that appear on the center line of this box, will represent units that have already been saved (from 0 to 99). If no units have yet been saved, the center line will be blank and therefore there are no setpoints to restore.
- Enter a number on the keypad that corresponds to the unit number that you wish to restore, then press [Enter].
- A progress bar will appear asking you to *Please Wait...*
- After the file has been written or updated, the dialog boxes will disappear, and you can either exit, or continue with another function.

**4) Delete Setpoints** – Use this option to delete the setpoints and custom text for a particular unit.:

- Ensure that all setpoint values have been documented as a safety precaution. Install the previously saved setpoints USB device into the provided connection on the Quantum™.
- Press the [4] button.
- The software program will read the USB device, and the following dialog box will appear:

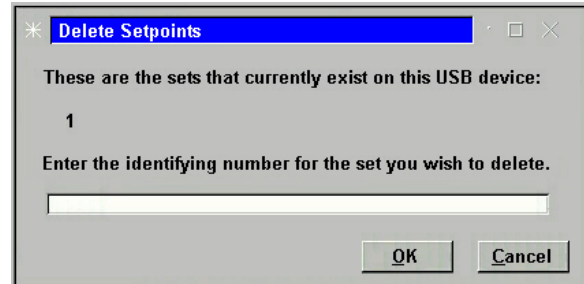

- Any numerals that appear on the center line of this box, will represent units that have already been saved (from 0 to 99). If no units have yet been saved, the center line will be blank, and therefore there are no setpoints to delete.
- Enter a number on the keypad that corresponds to the unit number that you wish to delete, highlight the *Ok* button, then press [Enter]. You will be prompted with a new dialog box which will ask you *OK to delete set number (0-99)?*
- Highlight the *Yes* button, and press [Enter]. The dialog box will be updated with a new message stating that *Set number (0-99) has been deleted!*
- Press [Enter] to return to the Software Maintenance menu.

**5) Exit** - Use this selection to leave this screen by pressing the [5] button, the panel will reboot and return to the **Operating Status** screen.

**6)** A box will then appear during reboot stating that a system update file has been found. The user should then select [Yes] to allow the operating system upgrade to complete. Once this completes, the user will be prompted to turn the power off, and then on again to allow the new system to boot.

## ABOUT

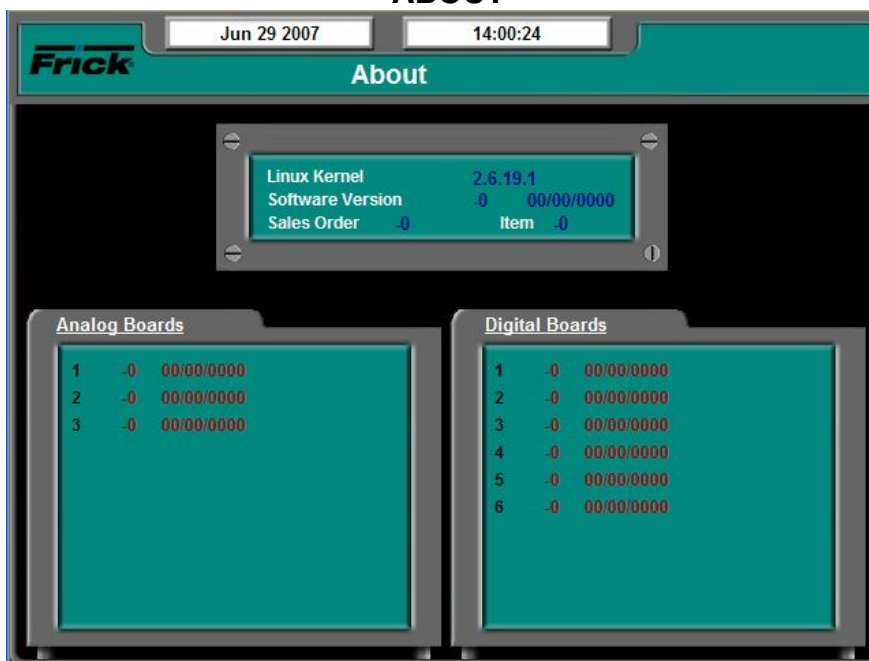

ACCESSING:



About

**DESCRIPTION:** The **About** screen shows all of the Digital and Analog boards that have been detected within any of the attached Condenser or Vessel panels by the Quantum™ LX, as well other related software information.

The following information is shown here:

**Linux Kernel** - The Quantum™ LX controller runs on a Linux operating system (rather than Microsoft Windows). This is the software version number for the main Linux Kernel.

**York Quantum Software** - This is the version of the software program that does the actual control of the Condenser/Vessel package. It runs in the Linux environment.

**Sales Order** - A six digit numerical value that has been assigned to a specific package by Frick Company. It is very important to have this number available when calling the factory for assistance or parts ordering.

**Item** - This is actually an extension of the Sales Order number. It would potentially be used for a multiple Condenser/Vessel site, where the same Sales Order number was assigned for all units. The Item Number would be different for each unit.

**Analog Boards** - Displays the analog board that were detected through communications at the last power up. If board were detected, the software version of the program running on that board (with date of the software) will be shown.

**Digital Boards** - Shows all digital boards that were detected through communications at the last power up. If boards were detected, the software version of the program running on that board (with date of the software) will be shown.

## MISCELLANEOUS SCREENS

### Alpha

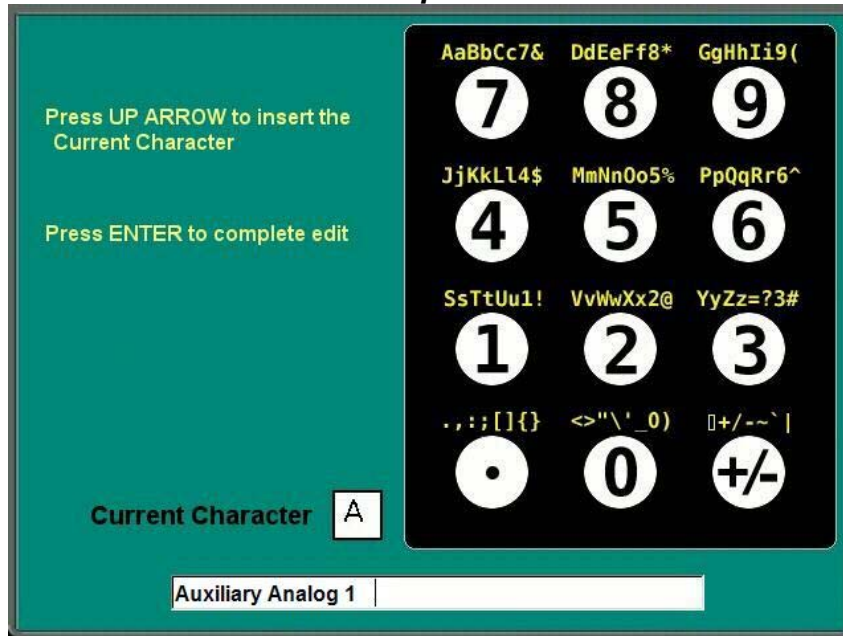

The **Alpha** screen shows a graphic representation of the Quantum™ LX numerical keypad. It is accessible from any screen that allows the user to enter alpha/numeric data, such as some of the Calibration screens, for example. The symbols that appear above each key on this screen, are the possible combinations of symbols that are associated with the digital portion of the key. Pressing any of these keys repeatedly will cause the characters immediately above the keys on the keypad to appear in the **Current Character** box. This is a similar technique that is used for sending text messages on a cellular phone.

As a example, suppose that you wanted to modify the text line in the screen example shown above. You want to change the line from reading Auxiliary Analog 1, to Packing Room 1. The first thing you would do, is to use the **[Backspace]** key on the keypad, to position the cursor (blinking vertical line), to the far left side of the text. Notice that each time the backspace key is pressed, the character to the left of the flashing cursor line is erased. Once the flashing cursor is at the beginning of the line,

press the number **[6]** key and notice that a capital **P**, for **P**acking appears in the **Current Character** box (**P** is the first symbol in the line right above the numeral **[6]** key). When the letter that appears in the **Current Character** Box is the one that you wish to select, press the **[^]** key (up arrow) to copy the **Current Character** to the bottom text line. Next press the **[7]** key twice, and notice that on the first press, a capital **A** appears, and on the second press, a lower case **a** appears (for **P**acking).

Continue entering the text using this method. When you need to enter a space, simply press the **[+/-]** key once, then the **[^]** (up arrow), a space will be entered on the text line.

Finish all text entry, and when you are satisfied that it is what you want, press the **[Enter]** key, which will cause the text entry screen to be replaced by the previous screen, then press the **[Submit]** key to accept the changes.

## Alarms/Shutdowns Messages

Following is the alphabetical listing of all the possible alarms:

**Analog Board 1 Comm. Shutdown Condenser** - The Quantum™ LX controller has lost communications to the Analog Board.

**Analog Board 2 Comm. Shutdown Vessel 0, 1 or 2** - The Quantum™ LX controller has lost communications to the Analog Board.

**Analog Board 3 Comm. Shutdown Vessel 0, 1 or 2** - The Quantum™ LX controller has lost communications to the Analog Board.

**Auxiliary Analog Input 0 - 19 High Warning Condenser** - A Condenser Warning has occurred and message issued because the input value to the Auxiliary Analog (0-19) input channel has exceeded its *High Warning Setpoint* value, and the *Delay* for that setpoint has timed out.

**Auxiliary Analog Input 0 - 11 High Warning Vessel** - A Vessel Warning has occurred and message issued because the input value to the Auxiliary Analog (0-11) input channel has exceeded its *High Warning Setpoint* value, and the *Delay* for that setpoint has timed out.

**Auxiliary Analog Input 0 - 19 Low Warning Condenser** - A Condenser Warning has occurred and message issued because the input value to the Auxiliary Analog (0-19) input channel has fallen below its *Low Warning Setpoint* value, and the *Delay* for that setpoint has timed out.

**Auxiliary Analog Input 0 - 11 Low Warning Vessel** - A Vessel Warning has occurred and message issued because the input value to the Auxiliary Analog (0-11) input channel has fallen below its *Low Warning Setpoint* value, and the *Delay* for that setpoint has timed out.

**Auxiliary Digital Input 0 - 10 Warning Condenser** - A Condenser *Warning* message was issued because the input value to the Auxiliary Digital Input (0-10) channel has been lost for a period of time greater than its *Delay* setpoint.

**Auxiliary Digital Input 0 - 17 Warning Vessel** - A Vessel *Warning* message was issued because the input value to the Auxiliary Digital Input (0-17) channel has been lost for a period of time greater than its *Delay* setpoint.

**Digital Board 1-3 Comm. Shutdown Condenser** - The Quantum™ LX controller has lost communications to the Digital Board, and has caused a shutdown.

**Digital Board 1 Reset Shutdown Condenser** - The Quantum™ LX controller has detected that the Digital Board has reset, and has caused a shutdown.

**Digital Board 2 Reset Shutdown Condenser** - The Quantum™ LX controller has detected that the Digital Board has reset, and has caused a shutdown.

**Digital Board 3 Reset Shutdown Condenser** - The Quantum™ LX controller has detected that the Digital Board has reset, and has caused a shutdown.

**Digital Board 4 Comm. Shutdown Vessel 0, 1 or 2** - The Quantum™ LX controller has lost communications to the Digital Board, and has caused a shutdown.

**Digital Board 4 Reset Shutdown Vessel 0, 1 or 2** - The Quantum™ LX controller has detected that the Digital Board has reset, and has caused a shutdown.

**Digital Board 5 Comm. Shutdown Vessel 0, 1 or 2** - The Quantum™ LX controller has lost communications to the Digital Board, and has caused a shutdown.

**Digital Board 5 Reset Shutdown Vessel 0, 1 or 2** - The Quantum™ LX controller has detected that the Digital Board has reset, and has caused a shutdown.

**Digital Board 6 Comm. Shutdown Vessel 0, 1 or 2** - The Quantum™ LX controller has lost communications to the Digital Board, and has caused a shutdown.

**Digital Board 6 Reset Shutdown Vessel 0, 1 or 2** - The Quantum™ LX controller has detected that the Digital Board has reset, and has caused a shutdown.

**Drain Sensor Fault Condenser** - This indicates that a shutdown has occurred, resulting from a failure of the Drain Temperature Sensor.

**High Level Shutdown (Digital) Vessel 0, 1 or 2** - A Vessel *Shutdown* message was issued because the input value to the Vessel High Level Digital Input channel has been lost for a period of time greater than its *Delay* setpoint.

**High Level Warning (Analog) Vessel 0, 1 or 2** - A Vessel *Warning* message was issued because the input value to the Vessel High Level Analog Input channel has been lost for a period of time greater than its *Delay* setpoint.

**High Level Warning (Digital) Vessel 0, 1 or 2** - A Vessel *Warning* message was issued because the input value to the Vessel High Level Digital Input channel has been lost for a period of time greater than its *Delay* setpoint.

**High Pressure Warning Condenser** - The Vessel Pressure was equal to or greater than the *High Pressure Warning* setpoint for its time delay.

**Low Level Shutdown (Digital) Vessel 0, 1 or 2** - A Vessel *Shutdown* message was issued because the input value to the Vessel Low Level Digital Input channel has been lost for a period of time greater than its *Delay* setpoint.

**Low Level Warning (Digital) Vessel 0, 1 or 2** - A Vessel *Warning* message was issued because the input value to the Vessel Low Level Digital Input channel has been lost for a period of time greater than its *Delay* setpoint.

**Low Level Shutdown (Analog) Vessel 0, 1 or 2** - A Vessel *Shutdown* has occurred and a message was issued because the input value to the Vessel Low Level Analog Input channel has been lost for a period of time greater than its *Delay* setpoint.

**Low Level Warning (Analog) Vessel 0, 1 or 2** - A Vessel *Warning* message was issued because the input value to

the Vessel Low Level Analog Input channel has been lost for a period of time greater than its *Delay* setpoint.

**Outside Air Temperature Sensor Fault Condenser** - This shutdown message is issued if the Outside Air Temperature reading was to the upper or maximum range (out of range) for its sensor.

**Outside Humidity Sensor Fault Condenser** - This shutdown message is issued if the Humidity reading was to the upper or maximum range (out of range) for its sensor.

**Pressure Sensor Fault Condenser** - This shutdown message is issued if the Pressure reading was to the upper or maximum range (out of range) for its sensor.

**Process Stopped Condenser** - One of the Condenser control program subroutine processes has stopped functioning and a message has been entered into the event log. This is a Warning message.

**Process Stopped Vessel 0 – 2** - One of the control Vessel program subroutine processes has stopped functioning and a message has been entered into the event log. This is a Warning message.

**Pump 0 High Side Pressure Sensor Fault Vessel 0, 1 or 2** - This shutdown message is issued if the Motor Amps reading was to the upper or maximum range (out of range) for its sensor.

**Pump 0 Low Side Pressure Sensor Fault Vessel 0, 1 or 2** - This shutdown message is issued if the Motor Amps reading was to the upper or maximum range (out of range) for its sensor.

**Pump 0 Motor Amps Sensor Fault Vessel 0, 1 or 2** - This shutdown message is issued if the Motor Amps reading was to the upper or maximum range (out of range) for its sensor.

**Pump 0 Pressure Differential Vessel 0, 1 or 2** - This warning message is issued if Pressure Differential Control is enabled, and the *Minimum Pressure Differential* setpoint is exceeded for a period greater than its time delay.

**Pump 1 High Side Pressure Sensor Fault Vessel 0, 1 or 2** - This shutdown message is issued if the Motor Amps reading was to the upper or maximum range (out of range) for its sensor.

**Pump 1 Low Side Pressure Sensor Fault Vessel 0, 1 or 2** - This shutdown message is issued if the Motor Amps reading was to the upper or maximum range (out of range) for its sensor.

**Pump 1 Motor Amps Sensor Fault Vessel 0, 1 or 2** - This shutdown message is issued if the Motor Amps reading was to the upper or maximum range (out of range) for its sensor.

**Pump 1 Pressure Differential Vessel 0, 1 or 2** - This warning message is issued if Pressure Differential Control is enabled, and the *Minimum Pressure Differential* setpoint is exceeded for a period greater than its time delay.

**Pump 2 High Side Pressure Sensor Fault Vessel 0, 1 or 2** - This shutdown message is issued if the Motor Amps reading was to the upper or maximum range (out of range) for its sensor.

**Pump 2 Low Side Pressure Sensor Fault Vessel 0, 1 or 2** - This shutdown message is issued if the Motor Amps reading was to the upper or maximum range (out of range) for its sensor.

**Pump 2 Motor Amps Sensor Fault Vessel 0, 1 or 2** - This shutdown message is issued if the Motor Amps reading was to the upper or maximum range (out of range) for its sensor.

**Pump 2 Pressure Differential Vessel 0, 1 or 2** - This warning message is issued if Pressure Differential Control is enabled, and the *Minimum Pressure Differential* setpoint is exceeded for a period greater than its time delay.

**Pump 3 High Side Pressure Sensor Fault Vessel 0, 1 or 2** - This shutdown message is issued if the Motor Amps reading was to the upper or maximum range (out of range) for its sensor.

**Pump 3 Low Side Pressure Sensor Fault Vessel 0, 1 or 2** - This shutdown message is issued if the Motor Amps reading was to the upper or maximum range (out of range) for its sensor.

**Pump 3 Motor Amps Sensor Fault Vessel 0, 1 or 2** - This shutdown message is issued if the Motor Amps reading was to the upper or maximum range (out of range) for its sensor.

**Pump 3 Pressure Differential Vessel 0, 1 or 2** - This warning message is issued if Pressure Differential Control is enabled, and the *Minimum Pressure Differential* setpoint is exceeded for a period greater than its time delay.

**Refrig. Level Sensor Fault Vessel 0, 1 or 2** - This shutdown message is issued if the Refrigerant Level reading was to the upper or maximum range (out of range) for its sensor.

**Refrig. Pump 0 Auxiliary Shutdown Vessel 0, 1 or 2**

**Refrig. Pump 0 Motor Amps Shutdown Vessel 0, 1 or 2**

**Refrig. Pump 1 Auxiliary Shutdown Vessel 0, 1 or 2**

**Refrig. Pump 1 Motor Amps Shutdown Vessel 0, 1 or 2**

**Refrig. Pump 2 Auxiliary Shutdown Vessel 0, 1 or 2**

**Refrig. Pump 2 Motor Amps Shutdown Vessel 0, 1 or 2**

**Refrig. Pump 3 Auxiliary Shutdown Vessel 0, 1 or 2**

**Refrig. Pump 3 Motor Amps Shutdown Vessel 0, 1 or 2**

**Step 0 - 23 Aux Fail Warning Condenser**

**Vessel Pressure Sensor Fault Vessel 0, 1 or 2** - This indicates that a Vessel shutdown has occurred, resulting from a failure of the Pressure Sensor.

## Index

### A

Active.....	44
Address Type.....	46
Alarm Silence.....	18
Alias Name.....	46
Analog ... 4, 6, 9-11, 28, 29, 31, 33, 34, 36-42, 49, 55	
Analog Boards.....	55
Auto.....	6
Automatic.....	6

### B

Baud Rate.....	44
----------------	----

### C

Cancel.....	6
Change Setpoints.....	6
Clear Safeties.....	18
Comm1.....	44
Common Terminology.....	6
Compressor ID.....	44
Condenser 4-10, 13-16, 18, 20, 22-24, 28-33, 36, 38, 40-43, 55-57	
Configuration.....	8
Control panel.....	5
Controller.....	5, 6, 55
Cooling.....	20
Cooling Control Setpoints.....	20
Cooling Dead Band.....	20
Cooling Integration Time.....	20
Cooling Proportional Band.....	20
Cursor.....	6

### D

Data Bits.....	44
Date.....	6, 8, 18, 19, 48, 49, 50, 51, 52
Date Format.....	48
Dead Band.....	20
Delete.....	6
Digital.....	4, 10, 11, 32, 33, 34, 49, 55
Digital Boards.....	55
Display.....	6

### E

Email.....	46, 47
EPROM.....	6
Ethernet.....	4, 46, 52

### F

Failed.....	44, 45
Flash Card.....	53, 54
Freeze.....	19

### G

Gateway Address.....	46
----------------------	----

### H

History.....	14
History Recording Interval.....	12
History trending.....	14
HTML.....	5
Hub.....	4

### I

I/O Comms.....	45
Icon.....	6
Integration Time.....	20
Interface.....	5
IP Address.....	46, 47
IP Data.....	46

### K

Key.....	6, 36, 37, 40, 41, 42
Keypad.....	5, 6

### L

Language.....	48
Level 0.....	47
Level 1.....	47
Linux Kernel.....	55

### M

Manual.....	6
Map File.....	45
Menu.....	7
Mode.....	20
Mode Column.....	23

### N

Non-volatile.....	6, 14
-------------------	-------

### O

OK.....	6
On.....	35
Operating Status.....	14, 18, 19
Operator Interface.....	4

### P

Panel Heater.....	35
Panel Status.....	15, 16, 17
Parity.....	45
Password.....	48
PID.....	20, 28, 29, 30
Pressure.....	36, 37

Pressure Units..... 48  
Protocol ..... 45, 47

**Q**

Quantum™ LX ..... 4, 5, 7, 8, 44, 47, 53, 55

**R**

Real Time Recording Interval ..... 12  
Remote..... 6  
Return Air Humidity ..... 41

**S**

Sales Order ..... 55  
Screen ..... 5-23, 28, 29, 35-53, 55  
Screen key ..... 6  
Screen Title ..... 8  
Setpoint..... 6, 20  
Shutdown ..... 6, 18, 19, 46  
SMTP Server Name ..... 47  
SMTP Server Port Number ..... 47  
Status ..... 8, 9, 10, 11, 12, 19, 44  
Stop Bits ..... 44  
Subject ..... 47  
Switch..... 4, 11, 26

**T**

Temperature ..... 20, 36, 37  
Temperature Units..... 48  
Time ..... 6, 8, 12, 15, 18, 19  
Time Column ..... 23  
Title Area ..... 6  
Tuning a PID Controller..... 30

**U**

Upgrading An Existing Program ..... 53, 54  
USB ..... 45  
User Defined ..... 9  
User Level ..... 48

**V**

Vessel... 4-9, 11-16, 25-27, 29-32, 34, 37, 38, 40-42,  
55-57  
Warning ..... 6, 18, 19  
Web browser ..... 4, 5, 6  
Web Server Port..... 46  
York Quantum Software ..... 55