



Form S90-560 M (MARCH 2008)

MAINTENANCE

File: SERVICE MANUAL - SECTION 90
Replaces: NOTHING
Dist: 3, 3a, 3b, 3c

MAINTENANCE

**FRICK[®] QUANTUM[™] LX
CONDENSER/VESSEL
CONTROL PANEL
VERSION 3.0x**

TABLE OF CONTENTS

INTRODUCTION TO THE QUANTUM™ LX CONDENSER/VESSEL CONTROL SYSTEM..... 4

- Quantum™ LX Control Panel Enclosure 4
- Condenser And Vessel Panels 4
- Operator Interface (Optional)..... 4

QUANTUM™ LX CONTROL PANEL 5

CONDENSER PANEL 6

VESSEL PANEL 7

POWER SUPPLIES FOR THE QUANTUM™ LX CONTROL PANEL AND CONDENSER/VESSEL PANELS 8

- Description 8
- Quantum™ LX Control Panel Power Supply 8
- Condenser/Vessel Panel Standard Power 9
- Replacement..... 9

QUANTUM™ LX CONTROLLER BOARD 10

- Introduction 10
- Troubleshooting The Quantum™ Control Panel 10
- General Information 10
- What To Do Before Calling The Factory..... 10
- Replacing The Quantum™ 4 Board 11
- What Should Occur When Applying Power 11
- Quantum™ LX Board Settings 13
 - Processor Board Jumpers..... 13
 - Communications Board Jumpers 13
 - Com-1 (TB) 13
 - Com-2 (TB2 - TB3) 13

DIGITAL BOARD..... 14

- Digital Board Description 14
- Communications LED's 14
- Connections To The Quantum™ 14
- Logic Voltage (Power) LED 14
- Active LED 15
- Digital Inputs 15
- Digital Outputs 15
- Checking The Digital Inputs And Outputs..... 15
- Fuse Testing And Replacement 16
- Input And Output Module Testing And Replacement 16
- Troubleshooting An Output..... 16
- Troubleshooting An Input 16
- Replacing A Defective Digital Board..... 16
- Condenser Panel Digital I/O Board #1 Pictorial 17
- Condenser Panel Digital I/O Board #2 Pictorial (Optional)..... 18
- Vessel Panel Digital I/O Board #1 Pictorial 19
- Vessel Panel Digital I/O Board #2 Pictorial (Optional) 20
- Digital Board Settings 21
 - Communications Settings 21
 - Dipswitch Settings..... 21

ANALOG BOARD 22

- Overview 22
- General Description 22
- Analog Board Description..... 22

Communications LED's 22
 Connections To The Quantum™ 22
 Logic Voltage (Power) LED's..... 23
 Active LED 23
 Analog Inputs 23
 Analog Outputs 24
 Troubleshooting The Analog Inputs And Outputs 24
 Replacing A Defective Analog Board 24
 Condenser Analog Board Pictorial 25
 Vessel Analog Board Pictorial 26
 Analog Board Settings 27
 Communications 27
 Miscellaneous 27
 Dipswitch Settings 27

SERVICE SCREENS 28

 Communications Log 28
 Communications Loop-Back Test..... 29
 Diagnostics 30
 Software Maintenance 31

MISCELLANEOUS MAINTENANCE SCREENS 33

 About 33

TROUBLESHOOTING A PROBLEM THAT APPEARS UNEXPLAINABLE 34

 Erasing The System Setpoints 34

WIRING DIAGRAMS 35

 Condenser Panel Digital Board 1 Inputs/Outputs..... 35
 Condenser Panel Optional Digital Board 2 Inputs/Outputs 37
 Condenser Panel Analog Board Inputs/Outputs 40
 Vessel Panel Digital Board 1 Inputs/Outputs 43
 Vessel Panel Analog Inputs/Outputs 50
 Communications Wiring Diagrams 53
 To Customer Remote Computer/DCS 53
 RS-485 Communications 53
 To Customer Remote Computer/DCS 53
 RS-422 Communications 53

RECOMMENDED SPARE PARTS 54

INDEX 56

THE FOLLOWING PUBLICATIONS ARE AVAILABLE FROM THE FRICK® WEBSITE frickcold.com

S90-560 CS	Frick® Quantum™ LX Condenser/Vessel Control Panel Communications Setup (setup and wiring for data communication using available protocols)
S90-560 M	Frick® Quantum™ LX Condenser/Vessel Control Panel Maintenance (repair and troubleshooting)
S90-562 O	Frick® Quantum™ LX Condenser/Vessel Control Panel Operation – Service



Indicates an imminently hazardous situation which, if not avoided, will result in death or serious injury.



Indicates a potentially hazardous situation or practice which, if not avoided, will result in death or serious injury.



Indicates a potentially hazardous situation or practice which, if not avoided, will result in damage to equipment and/or minor injury.

NOTE:

Indicates an operating procedure, practice, etc., or portion thereof which is essential to highlight.

INTRODUCTION TO THE QUANTUM™ LX CONDENSER/VESSEL CONTROL SYSTEM

The Quantum™ LX Condenser/Vessel system consists of three major control components:

- The Quantum™ LX Control Panel
- Condenser Panel
- Vessel Panel
- Optional Operator Interface

With the Quantum™ LX Condenser/Vessel system version 3.0x and later, a single Control Panel can control 23 Condenser steps, and/or up to three Vessels. It is also capable of Ethernet access, which can be viewed remotely through any web browser, or the optional Frick® Operator Interface Panel.

The Frick® Quantum™ LX control system consists of the following major areas:

QUANTUM™ LX CONTROL PANEL ENCLOSURE

The Frick® Quantum™ LX Condenser/Vessel control panel enclosure is configured to make it as standard as possible. This manual will describe the most common features and arrangements. It is always best to refer to the wiring diagrams, panel layouts, and operational documentation that is included with each unit for exact details regarding equipment operation.

- **Power Supply** - Provides the necessary operating voltages for the proper operation of all control components. Additional information about the power supply is located under the **POWER SUPPLY** section found later in this manual.
- **Quantum™ 4 Controller** - The Quantum™ 4 board runs a software program that communicates with all Panels, which in turn control the Digital and Analog boards within those panels. This communication allows the Quantum™ 4 to read the status of all the I/O boards, and display the data on either its own display, a Web Browser, or the optional Operator Interface Panel. The Quantum™ acts on this data, and provides the necessary control information to the I/O boards to provide the appropriate control of all input and output signals, based upon the configuration of installed features and options of the Condenser/Vessel package. Interaction to the outside world can be achieved through industry-standard communications protocols. Additional information is located under the **QUANTUM™ 4 CONTROLLER** section found later in this manual. The Quantum™ 4 controller, when loaded with the operating system, is then known as the Quantum™ LX system.

CONDENSER AND VESSEL PANELS

The Condenser and Vessel Panels contain the actual I/O that will control up to twenty-three steps of Condensing (for the Condenser panel), and up to three vessels (Vessel Panel). They are both connected to the Quantum™ Control panel via RS-485 communications.

- **Power Supply** - Provides the necessary operating voltages for the proper operation of all control components. Additional information about the power supply is located under the **POWER SUPPLY** section found later in this manual.
- **Digital Input / Output Boards** - Digital (on/off) signals are sent and received by these boards. The output signals are used for energizing solenoids, valves, contactors, relays, etc., and the input signals are used to sense the condition of switches, relay contacts, auxiliary contacts, etc. This board runs an independent software program from the Quantum™ LX to control devices, and communicates the status of all devices back to the Quantum™ LX. Additional information about the Digital Boards is located under the **DIGITAL BOARD** section found later in this manual.
- **Analog Input / Output Board** - Analog (variable) signals are sent and received by this board. The output signals are used for controlling damper motors, modulated valves, etc., and the input signals are used to read the values being sent from pressure transducers, temperature sensors, etc. This board runs an independent software program from the Quantum™ LX to control devices, and communicates the status of all devices back to the Quantum™ LX. The analog board contains 24 analog inputs, and 8 analog outputs. Additional information about this board is located under the **ANALOG BOARD** section found later in this manual.

OPERATOR INTERFACE

As defined earlier, the operator can access the control information through three possible methods: the central Quantum™ LX Control Panel, a web browser or the optional Operator Interface Panel. All interface methods perform the same task. They allow the operator to monitor and modify the operating parameters of any attached Condenser/Vessel units. The Operator Interface is basically a touch screen computer, that utilizes a web browser to monitor and control the Ethernet connected Quantum™ LX subsystem. Since the display is a touch-screen, there is no physical keyboard or mouse. The operator physically touches areas of the screen, and using a finger they can maneuver a mouse pointer around. Data and text are entered through a virtual onscreen keyboard.

QUANTUM™ LX CONTROL PANEL

The following pictorial shows front the Control Panel portion of the unit, and shows the following components:

- Enclosure
- Display
- Keypad
- Control Power Switch

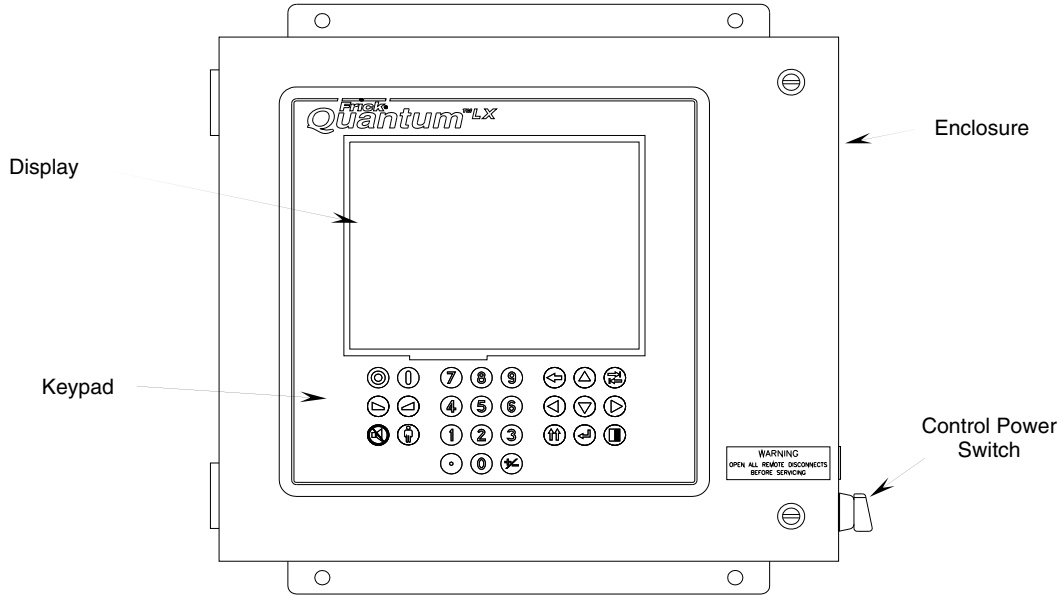

Front of Enclosure

The following pictorial shows the Control Panel portion of the unit with the door open, and shows the following components:

- Rear of Display
- Quantum™ LX Controller
- Communications Terminal Blocks (to panels)
- Power Supply
- 120 VAC Power Connection

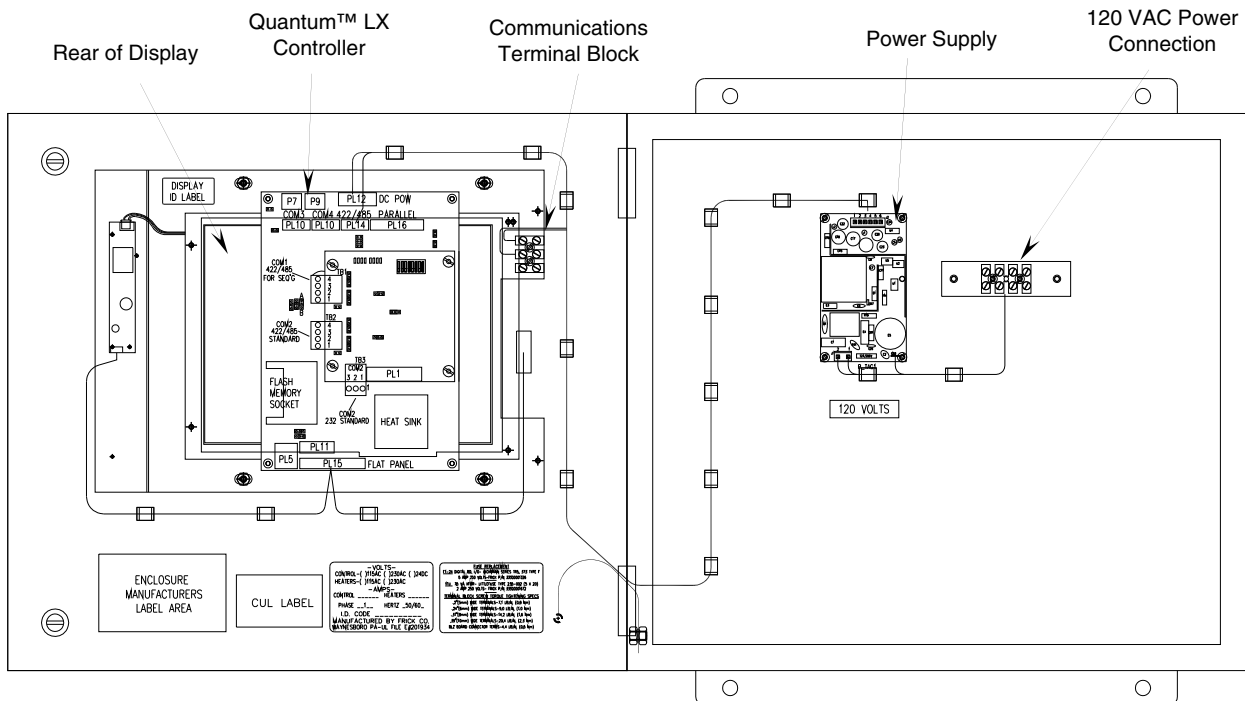

Inside of Enclosure

CONDENSER PANEL

The following two pictorials represent the Condenser panel. The first of these pictorials contain the following components:

- Digital and Analog control
- Fuses and circuit breakers
- HOA Modules.
- Optional Panel Heater
- Field and panel wiring terminals

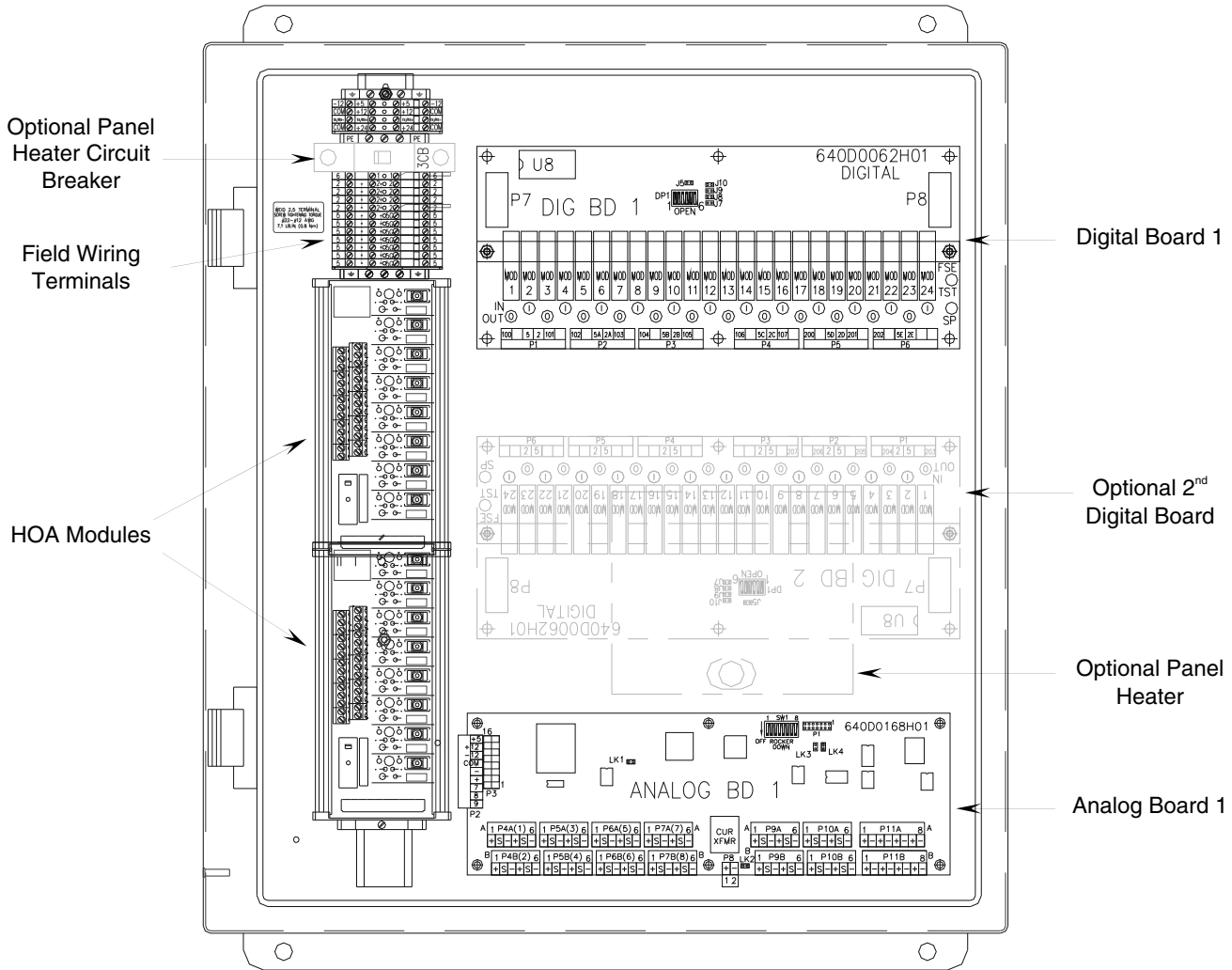

The following pictorial shows the inside, top of the enclosure. The power supply which provides the necessary DC voltages to power both the digital and

analog boards, as well as providing power to the analog channels is located here.

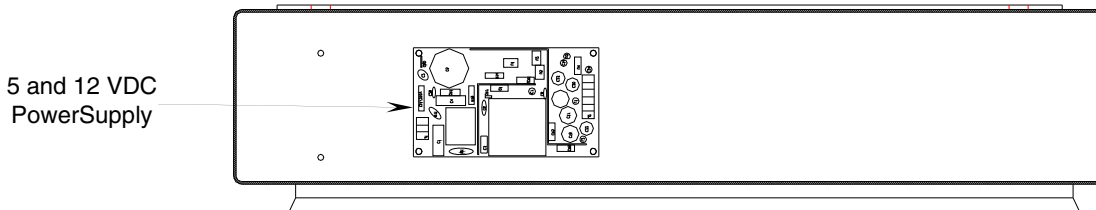

VESSEL PANEL

The following two pictorials represent the Vessel panel. The first of these pictorials contain the following components:

- Field and panel wiring terminals
- Digital and Analog control

- Fuses and circuit breakers
- HOA Modules.
- Optional Panel Heater

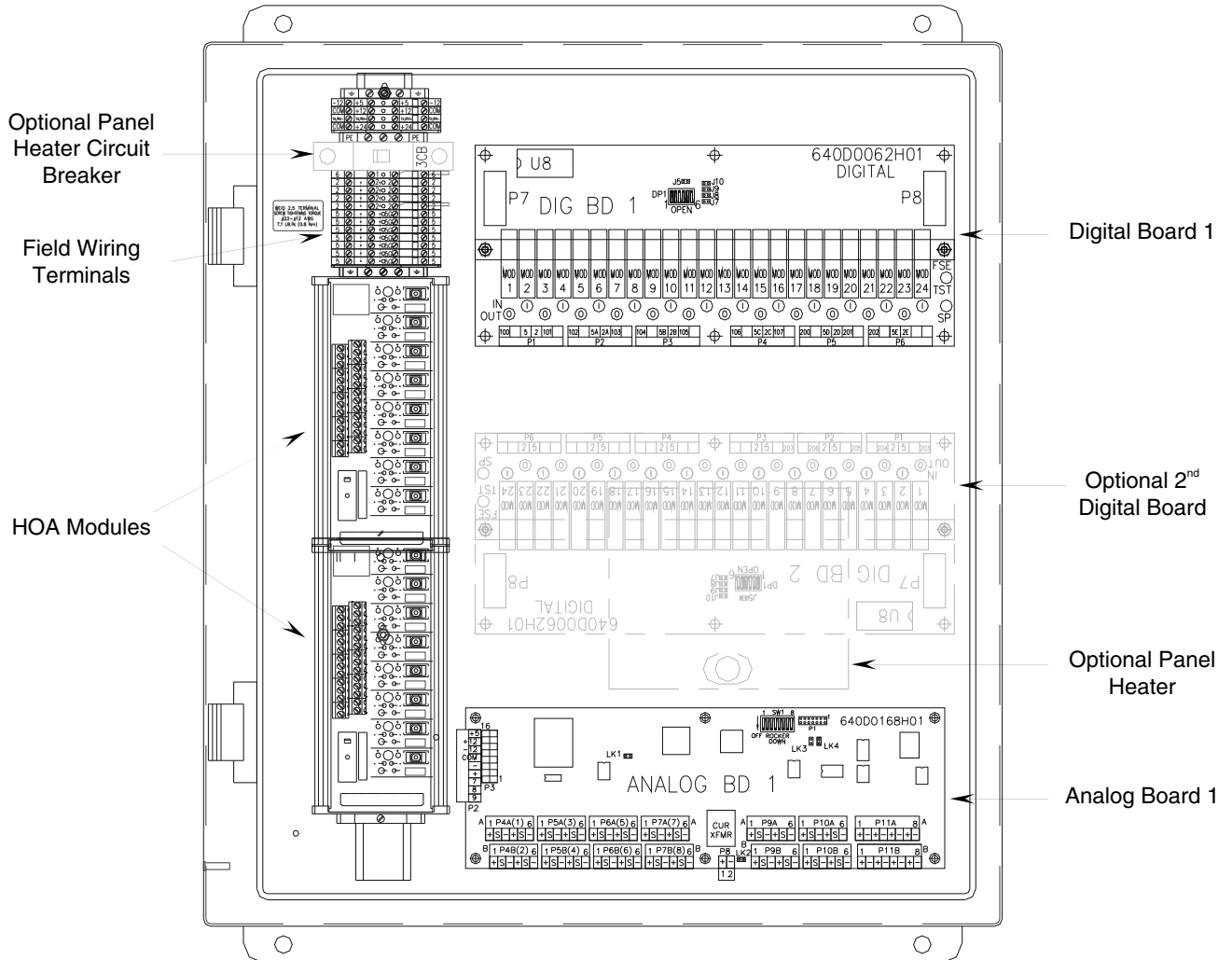

The following pictorial shows the inside, top of the enclosure. The power supply, which provides the necessary DC voltages to power both the digital and analog boards, as well as providing power to the analog

channels is located here. An optional power supply is also shown here.

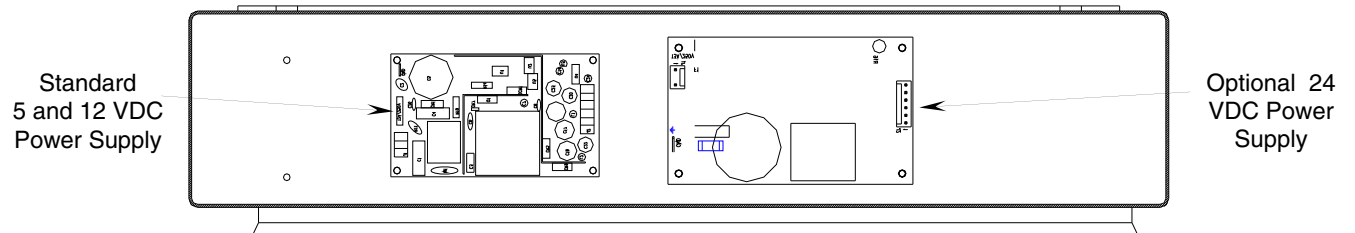

POWER SUPPLIES FOR THE QUANTUM™ LX CONTROL PANEL AND CONDENSER/VESSEL PANELS

DESCRIPTION

The same power supply is utilized in both the Quantum™ LX Control Panel, and the Condenser/Vessel Panels. A three-pin connector provides 120 VAC power to the supply, and a six-pin connector delivers DC power out of the supply. These connections are of a push-on multiple contact connector type. This power supply is not adjustable.

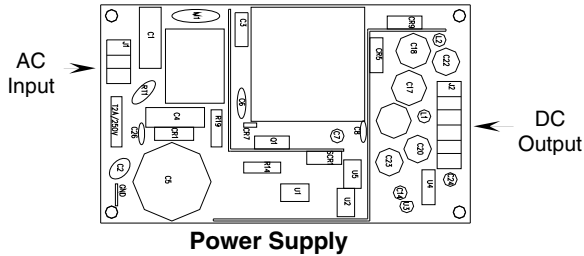

If the voltages from the power supply are within the acceptable ranges, then measure them at the Quantum™ control board, as shown below:

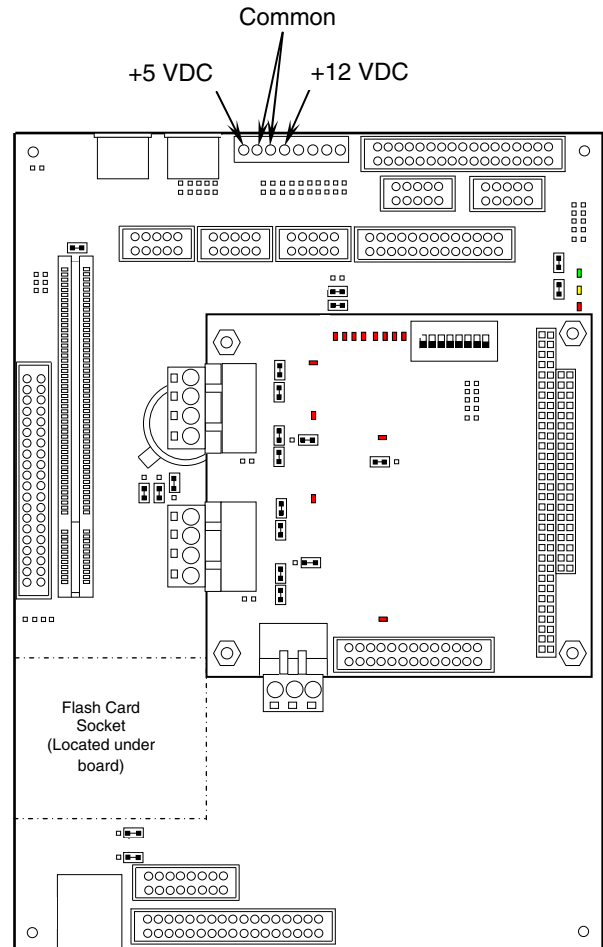

CAUTION! Measuring the power supply voltages require the control power to be energized. Extreme care must be observed when taking any readings, as 120 VAC is present within the power supply.

In order to properly measure the DC power, it must be checked at the Quantum™ LX controller (CPU) for the Control Panel, and verified for acceptable total voltage drop at the end of the daisy-chain (last I/O board) in the Panel.

QUANTUM™ LX CONTROL PANEL POWER SUPPLY

The Quantum™ LX controller utilizes only the +5 VDS and +12 VDC voltages from the power supply. To perform measurements on the power supply voltages, use a reliable, calibrated Digital Volt Meter (DVM). The DVM should be accurate to 1/100 of a volt DC. Turn the control power switch to *ON*.

Measure the voltages on the power supply at the DC output connector as shown below:

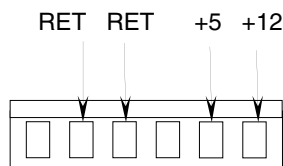

The following voltage range is considered to be acceptable:

- +5 VDC supply (+5.15 to +5.20 VDC)
- +12 VDC supply (+11.8 to +12.2 VDC)

If any of the measurements for the +5 or +12 VDC are not within recommended range, the power supply should be replaced.

CONDENSER/VESSEL PANEL STANDARD POWER

The Condenser and Vessel Panels both utilize the +5 VDC, +12 VDC and - 12 VDC voltages from its standard power supply. To perform measurements on the power supply voltages, use a reliable, calibrated Digital Volt Meter (DVM). The DVM should be accurate to 1/100 of a volt DC. Turn the control power switch to *ON*.

Measure the voltages on the power supply at the DC output connector as shown below.

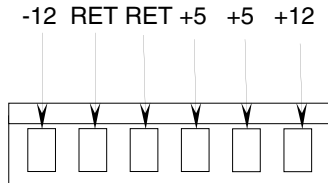

The following voltage range is considered acceptable:

- +5 VDC supply (+5.15 to +5.20 VDC)
- +12 VDC supply (+11.8 to +12.2 VDC)
- -12 VDC supply (-11.8 to -12.2 VDC)

If the voltages from the power supply are within the acceptable ranges, then measure them at the last I/O board in the daisychain, as shown below:

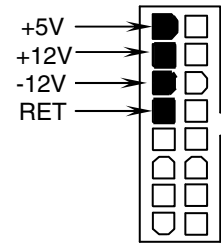

If any of the voltages measure outside of the acceptable range, yet measured correctly at the power supply, then a problem with the wiring harness should be suspected and checked.

REPLACEMENT

If the power supply is found to be bad, or out of adjustment, it will need replacing.

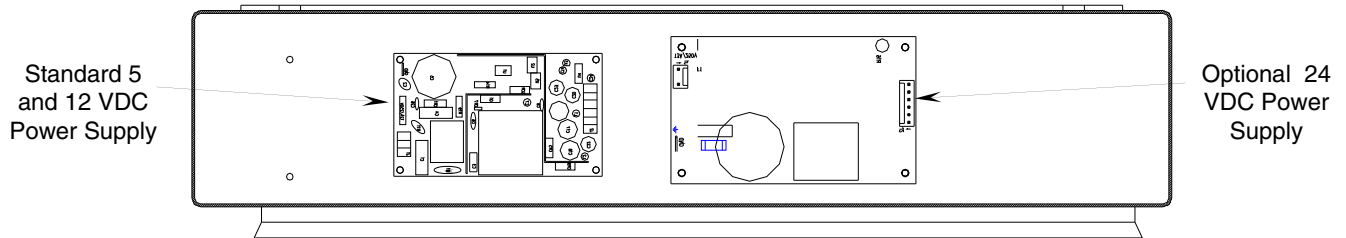

Power supply is located at the inside top of the Condenser Panel (Vessel Panel may also include the optional Power Supply)

QUANTUM™ LX CONTROLLER BOARD

INTRODUCTION

Frick® Controls strives to remain on the cutting edge of microprocessor technology and development. Because of the ever-increasing speed, memory features, and power of microprocessors, Frick® will continue to introduce the latest advancement in microprocessor control technology.

Although this manual is based on the Quantum™ LX operating system, the actual control board is known as the Quantum™ 4. The LX software is loaded onto it to provide control of the Condenser/Vessel system.

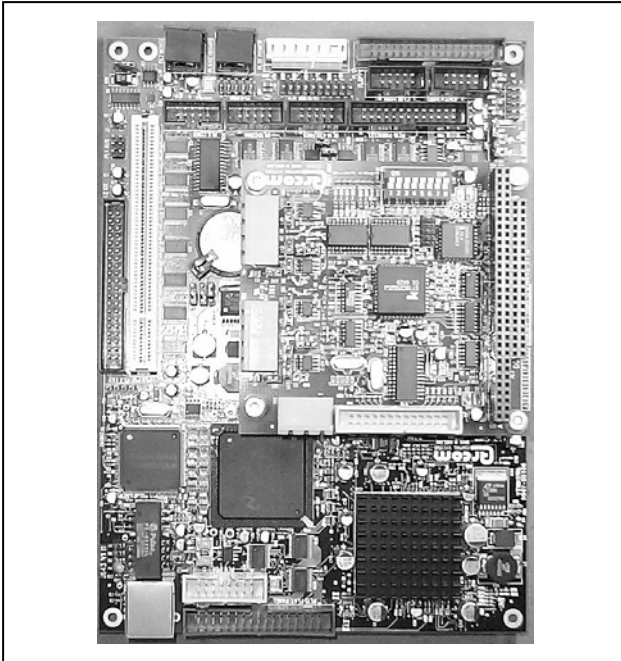

Quantum™ 4

TROUBLESHOOTING THE QUANTUM™ CONTROL PANEL

This section contains information on troubleshooting and making corrections to the boards and control circuits of the Quantum™ LX. Refer to the drawings at the end of this manual.

GENERAL INFORMATION

The components within the control panel can be inadvertently damaged by static electricity or mishandling. Only qualified technicians should directly handle these components.

1. DO NOT attempt to make corrections to the power supply without shutting off the power to the control panel. Accidental shorts can irreparably damage the processor boards or the display screen.
2. DO NOT HANDLE the panel boards when their cables are disconnected without first

attaching a properly grounded wrist ground strap to prevent static electrical discharge from your body.

Most problems encountered with the microprocessor and control circuits will be the result of a wiring fault, a blown fuse, faulty I/O module or failure of a peripheral control such as a solenoid coil or a pressure transducer. Faults in the computer, while possible, are unlikely. If a fault develops in the computer, the probability is that all functions will cease. The control system of the compressor consists of an AC (high voltage) side, which can be either 120 volts, or 230 volts, and a DC (low voltage) side. The AC side actuates solenoids, relays, alarms, and other electromechanical functions. The DC side operates the computer and its various sensors.

When working within the panel, the AC high voltage side, which can be either nominal 120 VAC or nominal 230 VAC, CAN CAUSE INJURY OR DEATH.

To troubleshoot the low-voltage side of the control circuits, it is necessary to have the following tools:

1. Accurate digital multi-meter (capable of reading DC/AC mA to the hundreds place)
2. Small wire stripper
3. Small screwdriver (with insulated shaft)
4. Small snip nose pliers
5. Wrist Grounding strap
6. Static free grounded work surface

Note: Proper panel voltage refers to the AC (high volt-age) that has been supplied to the panel, which could be either nominal 120 VAC or nominal 230 VAC (Reference the Control Panel Power Specifications).

Some problems that are encountered involve troubleshooting the panels digital inputs and outputs. The Digital I/O (Input/Output) boards have six Digital I/O (DIO) board connectors labeled P1 through P6. The input and output modules are wired into a DIO connector plug. Position 3 provides power and position 4 is a neutral on the DIO connectors.

WHAT TO DO BEFORE CALLING THE FACTORY

Many times when a suspected Quantum™ problem is called in to the factory, not enough information is provided for the service personnel to assist in solving the problem. This is because the caller most likely is not aware of the type of information that would be useful to factory personnel in helping to identify and correct the problem. An example of this is the statement that the Quantum™ is not booting (the

main processor board is not starting). Unfortunately, this description is usually vague and only means that nothing is showing on the web browser or the optional Operator Interface Panel. The following is a list of possible reasons for the Quantum™ 4 not to boot:

- No power (AC or DC)
- Loose or faulty cables
- Faulty CPU Board
- Tripped circuit breaker

Before calling the factory for assistance, review the information on the following pages and try to discover and resolve your Quantum™ 4 problem. The actual cause of most problems is usually not with the Quantum™ 4 itself, but with something external. However, on the rare occasion that the problem has been identified as being the controller, use the following section as a guideline for replacing it.

REPLACING THE QUANTUM™ 4 BOARD

The Flash Card memory load is done prior to the board shipping. The customer needs to have their settings manually recorded, or saved to a USB device, so that the new board can be setup the same as the old one. It is suggested that the operator first record all control setpoints prior to board replacement. **Factory Setup settings will also be lost.** A USB device will allow these setpoints to be saved electronically, and may be restored at a later time. Make sure that the operator can access Security Level 2 to restore all specific settings.

The procedure to replace the Quantum™ is outlined below:

1. Shut off control power.
2. Remove the old board from the machine and the new board from its packing and place both on an anti-static surface.
3. Ensure that the jumpers on the new board are set the same as those on the old board.
4. Install the flash card from the old board to the replacement board.

5. Install the modified replacement board into the panel.
6. If program changes are necessary through the USB port download, then follow the directions in the Software Maintenance section of this manual for the procedure to reload a program from the USB (see the section entitled **Software Maintenance**).

WHAT SHOULD OCCUR WHEN APPLYING POWER

The first thing that should be checked when troubleshooting the Quantum™ 4 is it's powering up sequence.

When powering up the Quantum™ 4 the following sequence of events are indicative of a properly working main processor board:

- Green PWR (Power) LED will turn on solid (upper right corner of main PCB).
- Red FLASH LED will begin to intermittently during the Boot process.
- LED D8 (on the smaller board) will start to blink at the rate of about once per second. It will continue to blink after the Quantum™ 4 has booted.
- LED's D4, D5, D7 and D9 will turn on solid.
- LED D11 and 12 will turn on solid. D4, D5, D7, D9, D10 and D13 will be flashing in random patterns. The flashing of the RX/TX lights of the Analog and Digital boards will also prove a successful boot.

After the Quantum™ 4 has properly powered up, the following sequence of events is indicative of proper communication to the analog and digital boards:

- The TX/RX LED's near the white connector will begin to blink.
- The Analog and Digital I/O boards TX/RX lights should be blinking.
- Each I/O board should have the power LED (next to the white connector) lighted and the *Active* LED (next to the blue Dipswitch) should be blinking.

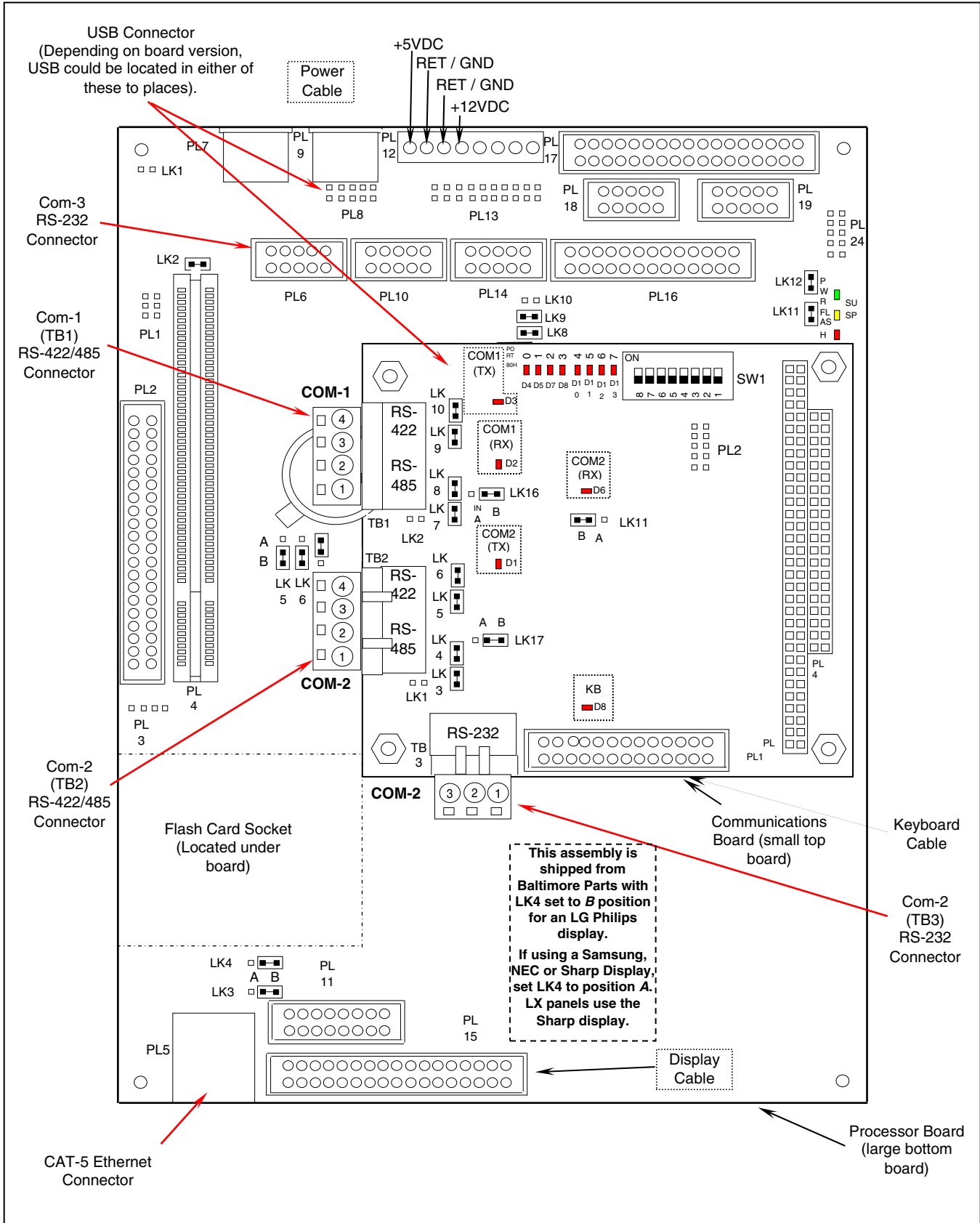

Quantum™ LX Controller Board Pictorial

Note: There are duplicate numbers for the links on the processor (larger) board and the communications (smaller) board. If you must make a change to a jumper (link), then ensure that you modify the correct link.

QUANTUM™ LX BOARD SETTINGS

Processor Board Jumpers

LK1	in out*	2 second Watchdog timer timeout 8 second Watchdog timer timeout
LK2	in* out	Watchdog timer Enabled Watchdog timer Disabled
LK3	A B *	+5V Backlight Voltage (Samsung, NEC, Sharp) +12V Backlight Voltage (LG Philips Display)
LK4	A * B	+5V LCD Supply (Samsung, NEC, Sharp) +3.3V LCD Supply (LG Philips Display)
LK5	A B *	COM4 IRQ3 COM4 IRQ10
LK6	A B *	COM3 IRQ4 COM3 IRQ11
LK7	A * B	Battery Backup Enabled Battery Backup Disabled (CMOS Cleared)
LK8	in* out	RS-485 Receiver Enabled RS-485 Receiver Disabled
LK9	in* out	RS-485 Terminated RS-485 Not Terminated
LK10	in out*	RS-422 Terminated RS-422 Not Terminated
LK11	in* out	Bit 1 of 259H "Logic 1" User Application Link Bit 1 of 259H "Logic 0" User Application Link
LK12	in* out	Bit 2 of 259H "Logic 1" User Application Link Bit 2 of 259H "Logic 0" User Application Link

* Standard Setting

Communications Board Jumpers

Com-1 (TB1)

LK2	in out*	Terminate COM1 No termination	RS-422/485
LK7	in out*	Pull down COM1 No pull down	RS-422/485 (Rx-/Tx-)
LK8	in* out	Pull up COM1 No pull up	RS-422/485 (Rx-/Tx+)
LK9	in out*	Pull down COM1 No pull down	RS-422 (Tx-)
LK10	in out*	Pull up COM1 No pull up	RS-422 (Tx+)
LK16	A B*	COM1 RS-422 (TB1) COM1 RS-485 (TB1)	

* Standard Setting

Com-2 (TB2 - TB3)

LK1	in out*	Terminate COM2 No termination	RS-422/485
LK3	in out*	Pull down COM2 No pull down	RS-422/485 (Rx-/Tx-)
LK4	in out*	Pull up COM2 No pull up	RS-422/485 (Rx-/Tx+)
LK5	in out*	Pull down COM2 No pull down	RS-422 (Tx-)
LK6	in out*	Pull up COM2 No pull up	RS-422 (Tx+)
LK11	A B*	Select RS-232 for COM2 (TB2) Select RS-422/RS-485 for COM2 (TB3)	
LK17	A B*	COM2 RS-422 (TB2) COM2 RS-485 (TB2)	

* Standard Setting

DIGITAL BOARD

The information that follows in this section can help locate problems that can occur with Digital Input and Output circuit boards, and their interaction with the Quantum™ 4 controller.

DIGITAL BOARD DESCRIPTION

The Digital Board is actually a small microprocessor board and programmed to control discrete outputs, or accept discrete inputs, from external electrical devices. Each Digital Board has the capability of 24 independent channels or I/O (Input/Output). With the Quantum™ LX Condenser/Vessel Control, some of these I/O channels are dedicated as to their function, through the operating system (software), enabled options and external wiring. Each channel that is used by the software will have a module plugged into it. A yellow module indicates that it is used for Inputs, a black module is used for Outputs. The standard Quantum™ LX Condenser/Vessel Control can have up to two Digital Boards (depending on options).

COMMUNICATIONS LED'S

The controller is in constant communication with all Digital (and Analog) Boards. You will notice on each Digital and Analog board, that there are a pair of LED's labeled as RX and TX. These letters represent Receive (RX) and Transmit (TX). These LED's should be flashing at a high rate during normal operation. This indicates that the Quantum™ 4, and the Digital Board that you are looking at, are properly communicating with each other.

- Reference the *JUMPER AND DIPSWITCH SETTINGS* section later in this manual. This section contains the dipswitch settings for addressing the Digital I/O Boards. When these switches are properly set, the Quantum™ 4 is able to serially communicate with each I/O board and provide control signals and data exchange. If these switches are not properly set, the result will be lost or failed communications, or the wrong outputs being energized, or the wrong inputs being received.

CONNECTIONS TO THE QUANTUM™

The Frick Condenser/Vessel control system utilizes up to two Digital, and one Analog Boards. To connect all of these boards together so that the Quantum™ 4 can control them, they must be interconnected with a wiring harness that provides all of the necessary D.C. voltage requirements, as well as the communications capabilities. A diagram of this wiring harness can be found later in this manual (see the Power I/O Wiring Harness drawing). The harness has an 18-pin connector at one end that plugs into the Quantum™. Another connector plugs into the power supply. The remaining three connectors (16-pin) will plug into each of the Digital and Analog Boards in the system (up to three total).

Upon close examination of this harness, you will notice that each of the connectors for both the Quantum™ and the three possible I/O boards, have two rows of connections. The wires that are inserted into the positions of one row, are internally daisy-chained on each I/O board, to continue the voltages and signals to the adjacent row. Therefore, any time that a connector is unplugged from the daisy-chain, these voltages and signals cannot continue through the daisy-chain to the next board. Whenever a plug is not to be inserted into a board, either for service or if not all boards are present, then a shunting plug (refer to Recommended Spare Parts list) must be installed onto the open connector.

The four wires that feed from the power supply to the Quantum™ 4 provide all of the necessary D.C. voltage that is required (+5 Vdc, -12 Vdc, +12 Vdc, and Return or Common). The voltages are passed through the connector on the Quantum™ 4, and two new signals are generated by the Quantum™ 4 to be passed on through the daisy-chain to the I/O boards. These two signals are the RX (receive) and TX (transmit). These signals are the means by which the Quantum™ communicates to the I/O.

The Digital Boards only require the +5 Vdc voltage and the Return (or common) for logic power. The communications signals (RX & TX) are required by all boards.

LOGIC VOLTAGE (POWER) LED

Located on the Digital Board is a *Power LED*. This LED will be illuminated as long as the *Control Power* switch is ON, and the proper voltage is present at the Quantum™ power supply. The power supply generates the +5 VDC voltage, and passes it on through the Power-I/O harness. This LED does not indicate however that the proper voltage is necessarily present at the board, only that the voltage is enough to energize the voltage sensing circuitry. If a voltage related problem is suspected with regard to a Digital Board, the only way to actually determine this is to read the voltage on a Digital Voltage Meter (DVM). This may be accomplished by locating the white power/communications connector on the board. Notice that the Digital Board has one of these connectors on both ends of the board. The associated power/communications harness will only be plugged into one of these connectors. Take the red (positive) probe of the DVM and carefully insert the end into the "+5V" lead, and the black (negative) probe end into the "RET" (Return or Common) lead, as shown below:

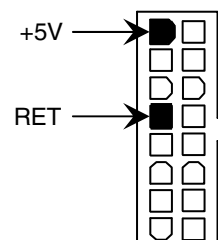

Set the DVM to read *DC*, and set the proper range. The voltage reading must read a minimum of +5.0 Vdc. The Power-I/O harness will have an associated voltage drop at each board connection. As an example, if you are reading the voltage at the first I/O board in the daisy-chain, and it reads 4.98 Vdc, you can be assured that the voltage at the subsequent connections for the remaining boards will be lower yet. The voltage will need to be corrected for proper operation of the system. The cause for a low voltage reading could be:

- The power supply may need adjustment (see the section on power supplies).
- The Power-I/O communications harness has a problem (a new harness may be needed).
- A problem may exist with one of the I/O boards (Digital or Analog).
- If the power LED is not lighted, check the cable for proper connectivity. **Note: Each board provides the necessary connections to feed all signals to the following connectors. If the auxiliary Analog or Digital Board is not present then a jumper plug (see Recommended Spare Parts List) must be installed to daisychain the signals.**

The most common symptom that is exhibited by a low +5 Vdc voltage to the Digital Boards is an alarm message that reads *Digital Board Reset Shutdown*.

ACTIVE LED

The Digital Board(s) have an *Active* LED indicator on the board that blinks when the board's software is running.

If the *Active* LED is not blinking, check to ensure that the EPROM is installed properly. The EPROM is located in chip slot U8, next to the power connector.

DIGITAL INPUTS

A Digital Input is the portion of the hardware that allows devices such as limit switches, relay contacts, and level switches, to interface with the Quantum™. The software program within the Quantum™ is constantly looking at these Input channels, via communications, and based upon whether a control voltage is present or not, will provide the necessary control for an associated Output channel.

The following pictorial shows a side view of the 120 VAC Input module. The color of an Input module is yellow:

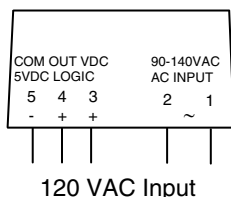

Never plug a 120 Volt Input module into a 240 Volt system, and vice-versa. Never plug an Output module into a position designated for an Input module.

You will notice that when a module is plugged into the Digital board, there is a fuse located directly adjacent to the module. This fuse is of the plugable variety, and must be plugged into the *IN* position for an Input module.

DIGITAL OUTPUTS

A Digital Output is the portion of the hardware that the Quantum™ is to control (energize). These devices include solenoids, relay coils, and heaters to be energized, based upon the logic within the Quantum™ LX software program.

The following pictorial shows a side view of the 120 VAC Output module. The color of an Output module is black:

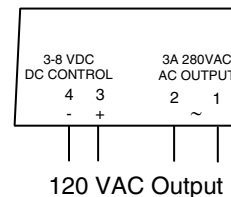

Although this Output module is labeled as 280 VAC on the top, and on the side, it can be used on both 120 and 240 volt applications.

Never plug an Input module into a position designated for an Output module.

You will notice that when a module is plugged into the Digital Board, there is a fuse located directly adjacent to the module. This fuse is of the plugable variety, and must be plugged into the *OUT* position for an Output module.

CHECKING THE DIGITAL INPUTS AND OUTPUTS

Some problems that may be encountered involve troubleshooting the digital inputs and outputs. The Digital I/O (Input / Output) Boards have six Digital I/O (DIO) board connectors labeled P1 through P6. The Input and Output modules are wired to a DIO connector plug. Position 3 provides power and position 4 is a neutral on the DIO connectors. Positions 1, 2, 5, and 6 are signal connections, as shown below:

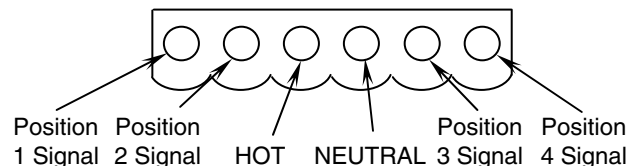

The Digital I/O board's I/O modules are configured by proper module selection, AC or DC, operating voltage, input or output, and moving the fuse to the *in* or *out* position. An LED is associated with each

module and displays the state of each module. A lit LED represents an Input that is *High*, receiving a signal or an Output that is *On*.

If a properly configured Digital I/O is not responding correctly, first look at the Digital Board on the **Digital I/O** Screen and check if the module is on. If it is not on, check if the LED on the Digital Board is also not lit. If the LED is not lit, then check the fuse. If the fuse is OK, then check the module.

FUSE TESTING AND REPLACEMENT

1. Power off the panel.
2. Open the panel door.
3. Remove the questionable fuse.
4. Place the questionable fuse into the fuse tester at the one end of each Digital I/O Board (refer to the Digital Board drawings at the end of this section for exact fuse tester location).
5. Power on the panel.
6. Check the LED on the tester. If the LED is lit, the fuse is OK.
7. Power off the panel.
8. If the fuse is faulty, check for external shorts on the corresponding circuit, then replace the fuse with a new plug-type fuse (refer to Recommended Spare Parts list).

INPUT AND OUTPUT MODULE TESTING AND REPLACEMENT

1. Power off the panel.
2. Open the panel door.
3. Replace the questionable module.
4. Power on the panel.
5. If it is an Output module, check for proper panel voltage on the DIO connector plug. Check the voltage between position 4 (neutral) and the associated position to the Output module.
6. If it is an Input module, check if the associated LED is on when power is applied to the module.

TROUBLESHOOTING AN OUTPUT

1. Make sure the LED associated with the Output is on when power is applied to the module.
2. If the LED is not on when it should be and there is no operating condition preventing it, contact the Frick® Service Department.
3. If the LED is on when it should be, check for proper panel voltage on the DIO connector plug. Check the voltage between the position 4 (neutral) and the associated position to the Output module.
4. If the voltage is OK, check for proper panel voltage between the associated position to the Output module on the DIO connector and the associated position on the terminal strip.
5. If the voltage is OK, check the wiring external to the panel.
6. If voltage is not OK, check the fuse.
7. If the fuse is OK then check the module.
8. If the module is OK, check for proper panel voltage on the DIO connector plug between position 3 (Hot) and position 4 (neutral).

TROUBLESHOOTING AN INPUT

1. Make sure the LED associated with the Input is on when power is applied to the module.
2. If the LED is on then the fuse and Input module are good.
3. If the LED is on and there is no input voltage, replace the Input module.
4. If the LED is not on when power is applied, check the fuse.
5. If the fuse is good, replace the Input module.
6. If you are receiving an Alarm or Shutdown from a digital input in which the adjacent LED indicator light is on, check the **Digital I/O** screen to see if that channel is turning on and off. If so, replace the input module.

REPLACING A DEFECTIVE DIGITAL BOARD

The procedure to replace a Digital board is outlined below:

1. Shut off control power.
2. Remove the old board from the machine and the new board from its packing and place both on an anti-static surface.
3. Remove any required chip(s) from the defective board and install them in the replacement board.
4. Check that all jumpers, dipswitches and components are properly setup on the new board using the old board as a reference (refer to the Digital Settings tables near the end of this section).
5. Install the modified replacement board in the panel.

After replacing or installing a Digital Board and powering on the control panel, select User Level 1 or higher, then select the **Setpoints** Menu, then the **Communications** Menu. On the Communications Screen is a button labeled as **[Redetect I/O Comms]**. Clicking on the **[Redetect I/O Comms]** button will cause the controller to examine the internal I/O communications of the panel, and initialize all connected boards. If a board has been removed, a communication error shutdown will be issued until this key is selected. The **About** screen will show what was detected.

The **[Redetect I/O Boards]** key will cause the controller to redetect all the I/O boards which are connected to the system. Once the redetect has completed, the controller will manage, and communicate with all the detected boards. Please refer to the **About** screen to verify that all I/O boards were correctly identified.

CONDENSER PANEL DIGITAL I/O BOARD #1 PICTORIAL

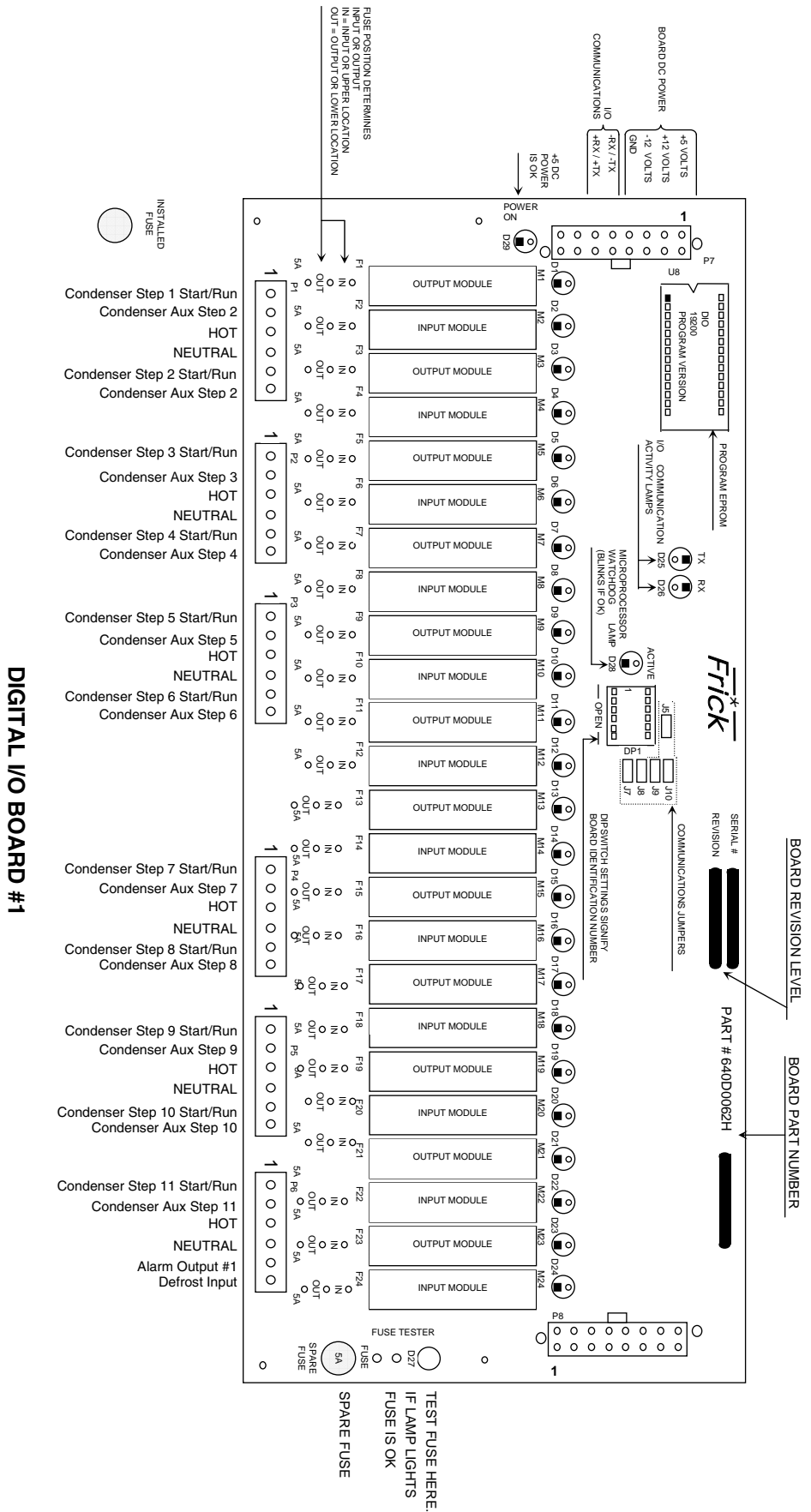

CONDENSER PANEL DIGITAL I/O BOARD #2 PICTORIAL (OPTIONAL)

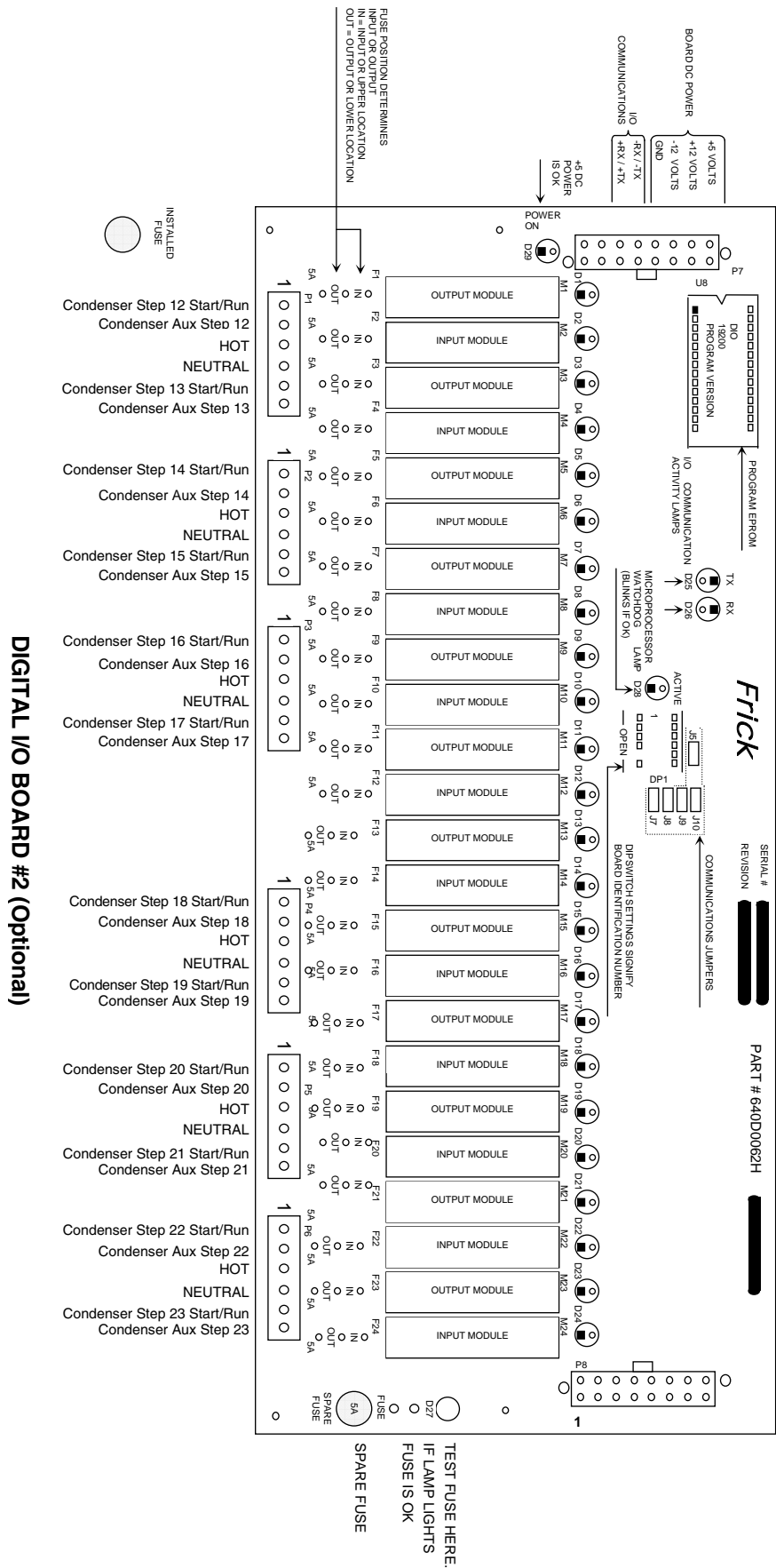

VESSEL PANEL DIGITAL I/O BOARD #1 PICTORIAL

DIGITAL I/O BOARD #1

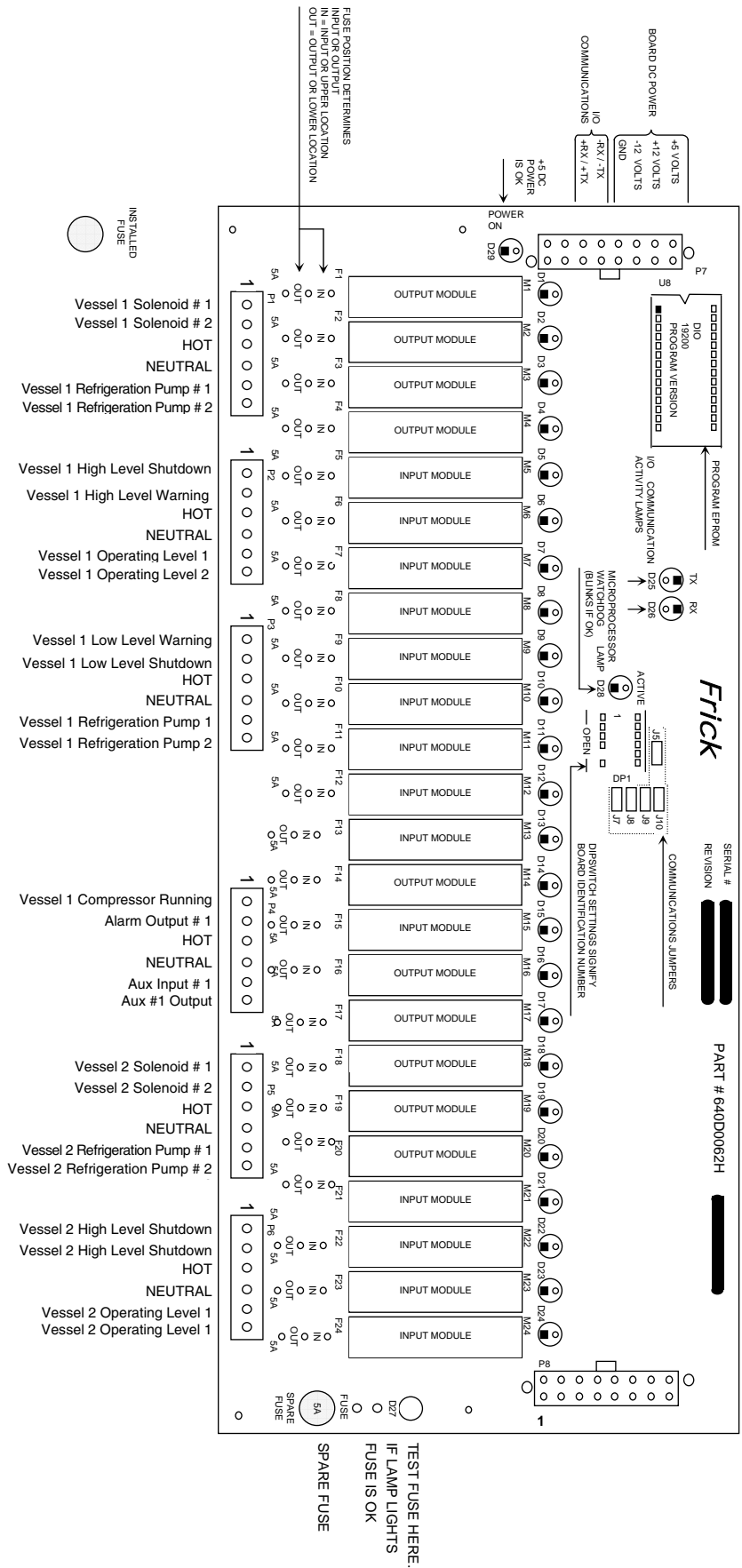

VESSEL PANEL DIGITAL I/O BOARD #2 PICTORIAL (OPTIONAL)

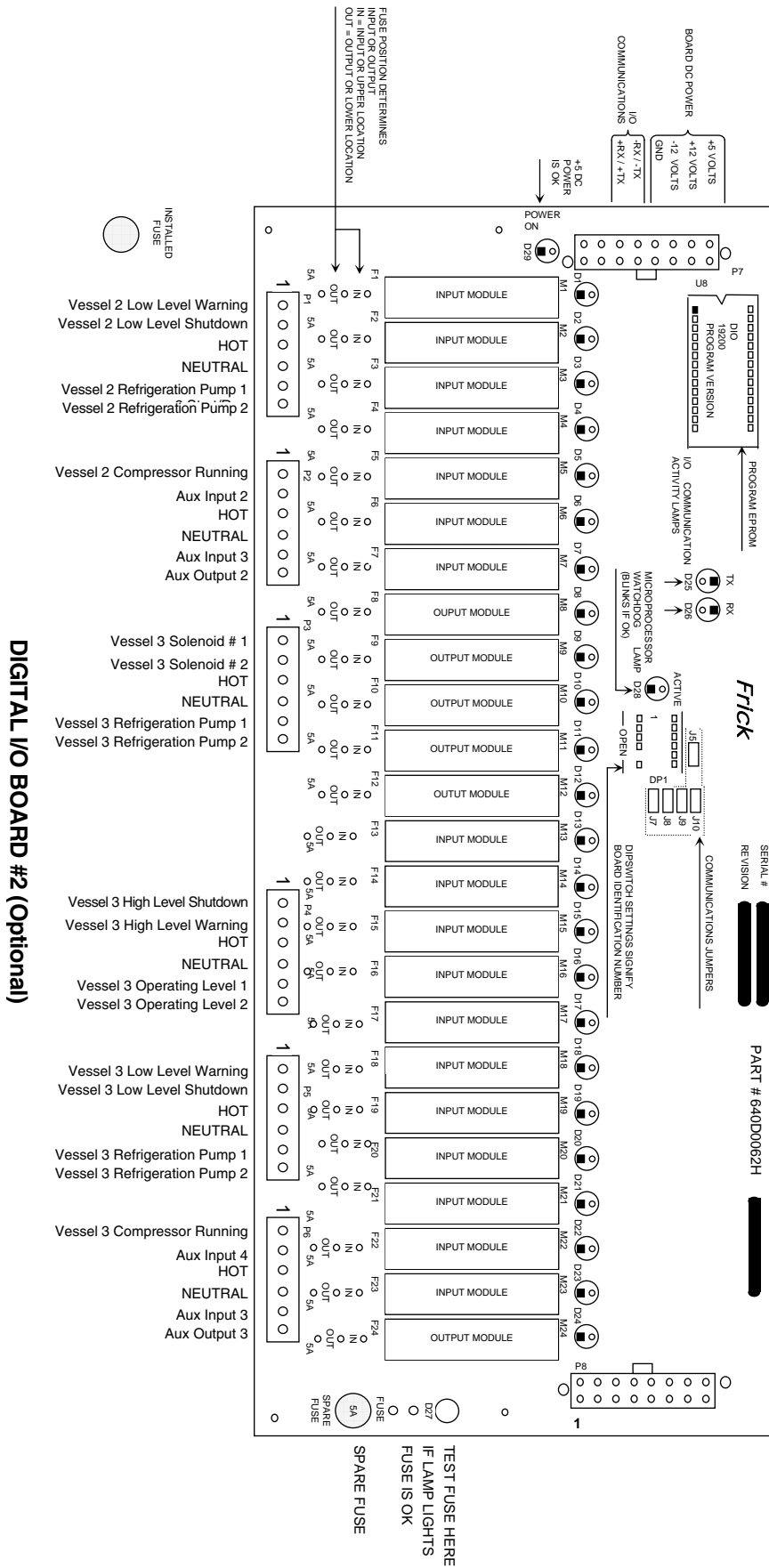

DIGITAL BOARD SETTINGS

COMMUNICATIONS SETTINGS

The following table is to be used when configuring the Quantum™ for external communications.

J5	in	120 ohm long communications line termination.
	out*	No termination.
J7	in	RS-422/485 transmit pull-up for long communications lines.
	out*	No pull-up.
J8	in	RS-422 transmit pull-up for long communications lines.
	out*	No pull-up.
J9	in	RS-422/485 receive pull-down for long communications lines.
	out*	No pull-down.
J10	in	RS-422 receive pull-down for long communications lines.
	out*	No pull-down.

* = standard setting

DIPSWITCH SETTINGS

The following table is to be used to set the digital board addresses. Refer to and study the diagram at the bottom of this page to determine the correct board configuration.

Condenser Digital Board DIP Switch Settings						
Digital Board #	SW1	SW2	SW3	SW4	SW5	SW6
1	On	On	On	On	Off	On
2	Off	On	On	On	Off	On

Vessel Digital Board DIP Switch Settings						
Digital Board #	SW1	SW2	SW3	SW4	SW5	SW6
4	Off	Off	On	On	Off	On
5	On	On	Off	On	Off	On

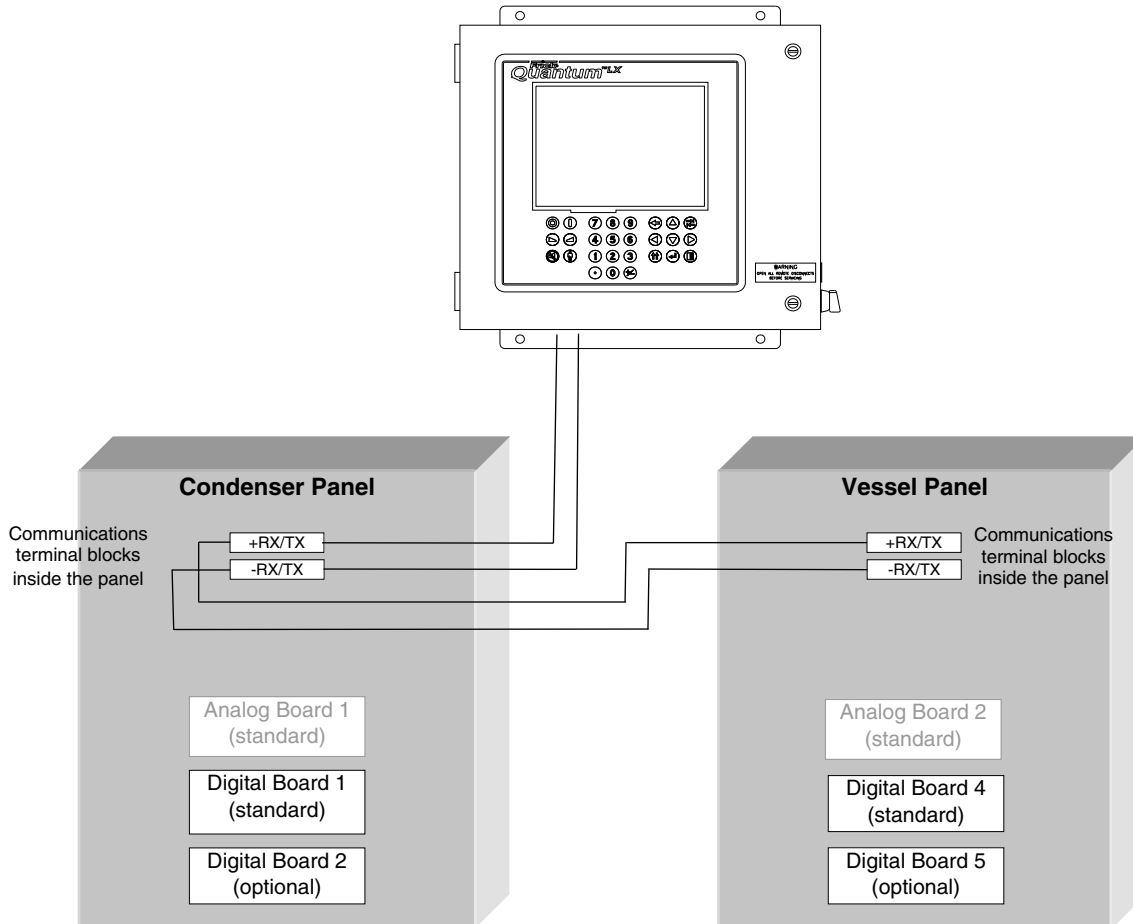

The above diagram represents a possible communications daisy-chain scheme.

ANALOG BOARD

OVERVIEW

The Frick Quantum™ LX Condenser/Vessel control panel is capable of reading external analog devices, such as temperature probes and pressure sensors. It uses these input signals for the purpose of monitoring and control. As an example, if an external temperature sensor begins to read a higher than expected temperature in some area, the controller would sense this change, and provide the necessary output control signal to remedy the situation, or provide a warning. Unlike a digital signal, which is typically either an on or off state, an analog signal can assume a wide range of values, such as a temperature probe's reading a wide range of temperatures.

The method used for receiving (and sending) these signals, is the analog board. The analog devices are wired directly to the board, and the on-board software/hardware converts the electrical signals received from these devices into data, which is then sent on to the Quantum™ 4 control board via communications, and is monitored by the control software.

GENERAL DESCRIPTION

This board features twenty-four input channels, and eight output channels. The board channels are configured through software, rather than using physical jumpers. A more detailed description of the operation of this board is provided in the sections that follow. A drawing of this board is shown here:

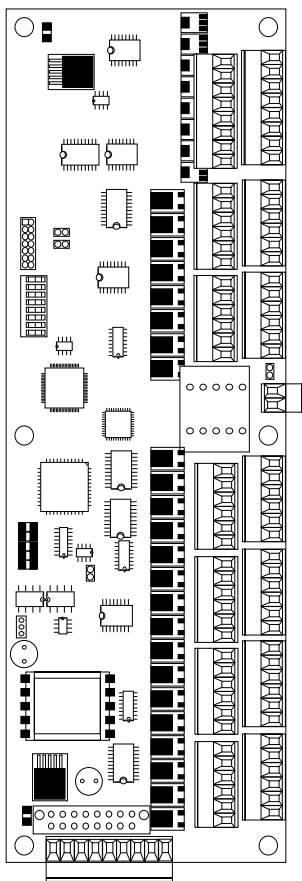

ANALOG BOARD DESCRIPTION

The Analog Board is actually a small microprocessor board and is programmed to control analog outputs, or accept analog inputs, from external electrical devices. Each enhanced board has the capability of 24 independent input channels. With the Quantum™ Compressor Control, these I/O channels are dedicated through the software and external wiring, as to the function of each channel.

COMMUNICATIONS LED'S

The Quantum™ controller is in constant communication with the Analog (and Digital) Board(s). You will notice on each Analog and Digital board, that there is a pair of LED's that are labeled as RX and TX. These letters represent receive (RX) and Transmit (TX). These LED's should be flashing at a high rate during normal operation. This indicates that the Quantum™ LX, and the board that you are looking at, are properly communicating with each other.

- Refer to the *JUMPER AND DIPSWITCH SETTINGS* section later in this section. This section contains the dipswitch settings for addressing the Analog I/O Boards. When these switches are properly set, the Quantum™ LX is able to serially communicate with each I/O board and provide control signals and data exchange. If these switches are not properly set, the result can be one of the following:
 - Lost or failed communications (displayed in the *Communications Status* box on the Home screen)
 - The wrong analog input signals being received
 - The wrong analog output signals being sent from the board.

CONNECTIONS TO THE QUANTUM™

As stated earlier, the Quantum™ Condenser/Vessel control system utilizes up to two Digital, and one Analog Board. In order to connect all of these boards together so that the Quantum™ can control them, they must be interconnected with a wiring harness that provides all of the necessary D.C. voltage requirements, as well as the communications capabilities. A diagram of this wiring harness can be found later in this manual (see the Power I/O Wiring Harness drawing). This harness has a 6-pin connector at one end that plugs into the Quantum™. Another connector plugs into the power supply. The remaining three connectors (16 pin) will plug into each of the Digital and Analog Boards in the system.

Upon close examination of this harness, you will notice that each of the connectors for both the Quantum™ and the I/O boards, have two rows of connections. The wires that are inserted into the

positions of one row, are internally daisy-chained on each I/O board, to continue the voltages and signals to the adjacent row. Therefore, any time that a connector is unplugged from the daisy-chain, these voltages and signals cannot continue through to the next board. Whenever a plug is not to be inserted onto a board, either for servicing, or if not all boards are present because of the options that are present, then a shunting plug (refer to the Recommended Spare Parts list) must be installed onto the open connector.

The four wires that feed from the power supply to the Quantum™ provide all of the required D.C. voltages (+5 Vdc, -12 Vdc, +12 Vdc, and Return or Common). The voltages are passed through the connector on the Quantum™, and two new signals are generated by the Quantum™ to be passed on through the daisy-chain to the I/O boards. These two signals are the RX (receive) and TX (transmit). These signals are the means by which the Quantum™ LX communicates to the I/O.

The Analog Board requires the +5 Vdc for logic, the -12 Vdc for internal voltage reference, and +12 Vdc for external sensors (plus or +) and the Return (common or -). The communications signals (RX & TX) are required by all boards.

LOGIC VOLTAGE (POWER) LED'S

Located on the Analog Board are two power LED's. The first of these is D1 LED (+5VDC), and will be illuminated as long as the Control Power switch is ON, and the proper voltage is present at Analog Board connector P3. The power supply generates the +5 VDC voltage, and passes it on through the Power-I/O harness. This LED does not indicate however that the proper voltage is necessarily present at the board, only that the voltage is enough to energize the voltage sensing circuitry.

If a voltage related problem is suspected with regard to the Analog Board, the best way to actually determine this is to read the voltage on a DVM (Digital Volt Meter). This may be accomplished by locating the white power / communications connector on the board. Notice that the Analog Board has only one of these connectors. The associated power / communications harness plugs in to it. Take the red (positive) probe of the DVM and carefully insert the end into the +5V lead, and the black (negative) probe end into the RET (Return or Common) lead, as shown below:

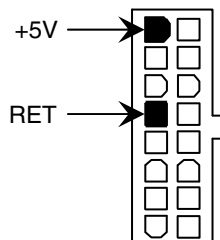

Set the DVM to read DC, and set the proper range. The voltage reading must read a minimum of +4.98

Vdc. The Power-I/O harness will have an associated voltage drop at each board connection. As an example, if you are reading the voltage at the first I/O board in the daisy-chain, and it reads 4.98 Vdc, you can be assured that the voltage at the subsequent connections for the remaining boards will be lower yet. The voltage will need to be corrected for proper operation of the system.

The cause for a low voltage reading could be:

- The Quantum™ power supply may need adjustment (see the section on power supplies).
- The Power-I/O communications harness has a problem (a new harness may be needed).
- A problem may exist with one of the I/O boards (Digital or Analog).
- If the power LED is not lighted, check the cable for proper connectivity. **Note: Each board provides the necessary connections to feed all signals to the following connectors. If the auxiliary Analog or Digital Board is not present then a jumper plug (Part # 640B0039H01) must be installed to daisy-chain the signals.**

The second power LED is D5 (+24Vdc). This +24Vdc voltage is generated on the Analog Board from the +5Vdc supply being fed from the Quantum™ LX power supply. If the +5Vdc is present as stated earlier, then this LED will illuminate if the on-board +24Vdc supply is functioning properly.

ACTIVE LED

The Analog Board has an *Active* LED indicator that blinks when the board's software is running.

If the *Active* LED is not blinking, it could be an indication that the internal program is not running. Try powering the Quantum™ 4 controller off, then back on to see if the *Active* light starts blinking. If not, a new board may be required.

ANALOG INPUTS

An Analog Input is the portion of the hardware that allows devices such as temperature sensors and pressure transducers, to interface with the Quantum™ 4. The software program within the Quantum™ 4 is constantly looking at these Input channels, via communications, and based upon what the voltage or current level of the channel is, will provide the necessary control for an associated action.

Analog inputs arrive at the board on connectors P4 through P10. Each of these connectors can receive two channels (for a total of twenty-four).

ANALOG OUTPUTS

An Analog Output is the portion of the hardware that the Quantum™ 4 uses to provide control. These outputs are dedicated for a 4-20 mA signal and cannot be changed through the software configuration.

TROUBLESHOOTING THE ANALOG INPUTS AND OUTPUTS

Some problems that may be encountered involve troubleshooting the Analog inputs and outputs. The Analog Board has twelve Analog I/O board connectors labeled P4 through P10. The external Analog devices are wired to a connector plug. Position 1 connects to the plus (+) of the external device for channel 1, position 2 connects to the signal (SIG) of the external device for channel 1 and position 3 connects to ground (GND) of the external device for channel 1. Position 4 connects to the plus (+) of the external device for channel 2, position 5 connects to the signal (SIG) of the external device for channel 2 and position 6 connects to ground (GND) of the external device for channel 2, as shown below:

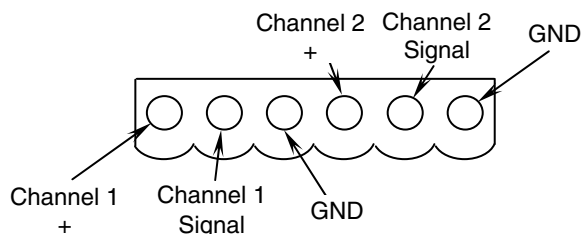

Each input channel is configurable through the operating software. There are twenty-four analog input channels that can be selected for 4-20 mA, 0-5 Vdc, ICTD, or RTD. Besides properly setting the software configuration, each channel is setup through software calibration for the proper transducer type and range, and each transducer must be calibrated through the appropriate sensor calibration screen. Improper setup of either the hardware or software will result in incorrect operation or range.

The most common fault associated with the improper reading of the analog channels other than hardware or software setup problems fall into one of the following categories:

- Sensor fault
- Wiring problem
- Improper grounding of system.

An open wire, shorted wire, or faulty sensor will usually give a reading at either the minimum or maximum end of the range scale. An erratic reading or a reading that seems to float up and down is usually indicative of a grounding problem. When a single transducer or cable is shorted to earth (or system) ground, this can show up as a whole assortment of problem channels. The easiest way to

find a short to earth problem is to disconnect all the sensor plugs and ohm out each plug screw terminal to earth for open (infinite) impedance. All sensors should read open to earth. The third pin on pressure sensors is ground.

REPLACING A DEFECTIVE ANALOG BOARD

The procedure to replace an Analog board is outlined below:

1. Ensure that all channel configuration information for the board being replaced has been written down.
2. Shut off control power.
3. Unplug all connectors from the board.
4. Remove the old board from the unit and remove the new board from its packing and place both on an anti-static surface.
5. Check that all jumpers, dipswitches and components are properly setup on the new board using the old board as a reference (refer to the Analog Settings tables near the end of this section).
- 6.
7. Install the modified replacement board in the panel.
8. Plug all connectors back in.
9. Turn on control power.
10. After the Quantum™ 4 has rebooted, access the Analog Board Configuration Setup screen, and re-enter the correct channel configuration. The default setup of the new board will be loaded to the processor. It is imperative that the channel configuration screen be accessed to ensure that the channels are configured properly for the application.

After replacing or installing an Analog Board and powering on the control panel, select User Level 1 or higher, then select the **Setpoints** Menu, then the **Communications** Menu. On the Communications Screen is a button labeled as **[Redetect I/O Comms]**. Clicking on the **[Redetect I/O Comms]** button will cause the controller to examine the internal I/O communications of the panel, and initialize all connected boards. If a board has been removed, a communication error shutdown will be issued until this key is selected. The **About** screen will show what was detected.

The **[Redetect I/O Boards]** key will cause the controller to redetect all the I/O boards which are connected to the system. Once the redetect has completed, the controller will manage, and communicate with all the detected boards. Please refer to the **About** screen to verify that all I/O boards were correctly identified.

VESSEL ANALOG BOARD PICTORIAL

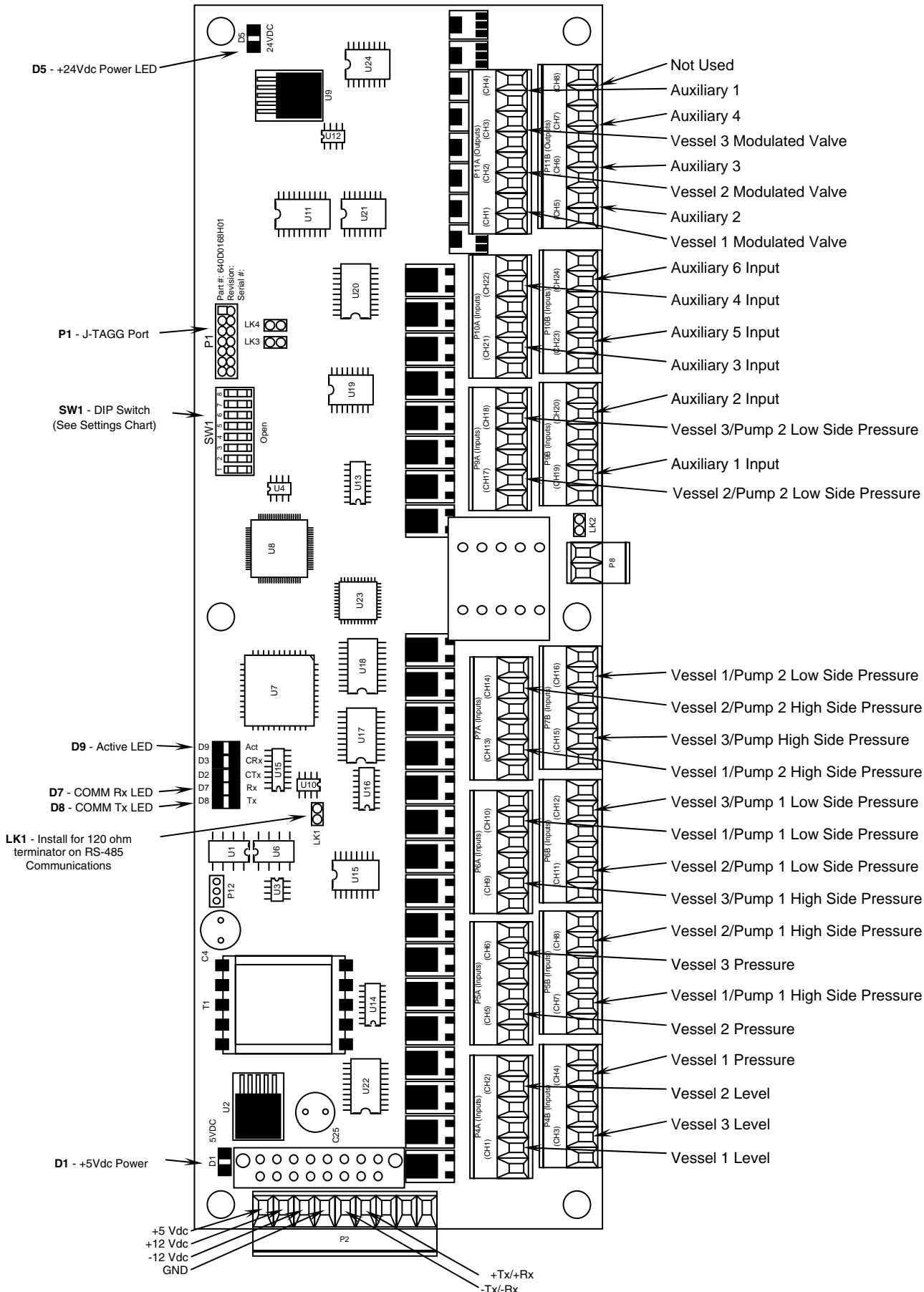

ANALOG BOARD SETTINGS

COMMUNICATIONS

The following table is to be used when configuring the Quantum™ for external communications.

LK1	In	120 ohm long communications line termination.
	Out *	No termination.

* default setting

MISCELLANEOUS

LK2	In	Not Used
	Out *	Not Used
LK3	In	Not Used
	Out *	Not Used
LK4	In	Not Used
	Out *	Not Used

* default setting

NOTE: Although LK2, 3 and 4 are not used, they must still be set for the default positions.

DIPSWITCH SETTINGS

The following table is to be used to set the analog board addresses. Refer to and study the diagram at the bottom of this page to determine the correct board configuration.

Condenser Analog Board DIP Switch Settings								
Analog Board #	SW1	SW2	SW3	SW4	SW5	SW6	SW7	SW8
1	Off	Off	Off	Off	Off	Off	Off	Off

Vessel Analog Board DIP Switch Settings								
Analog Board #	SW1	SW2	SW3	SW4	SW5	SW6	SW7	SW8
2	On	Off	Off	Off	Off	Off	Off	Off

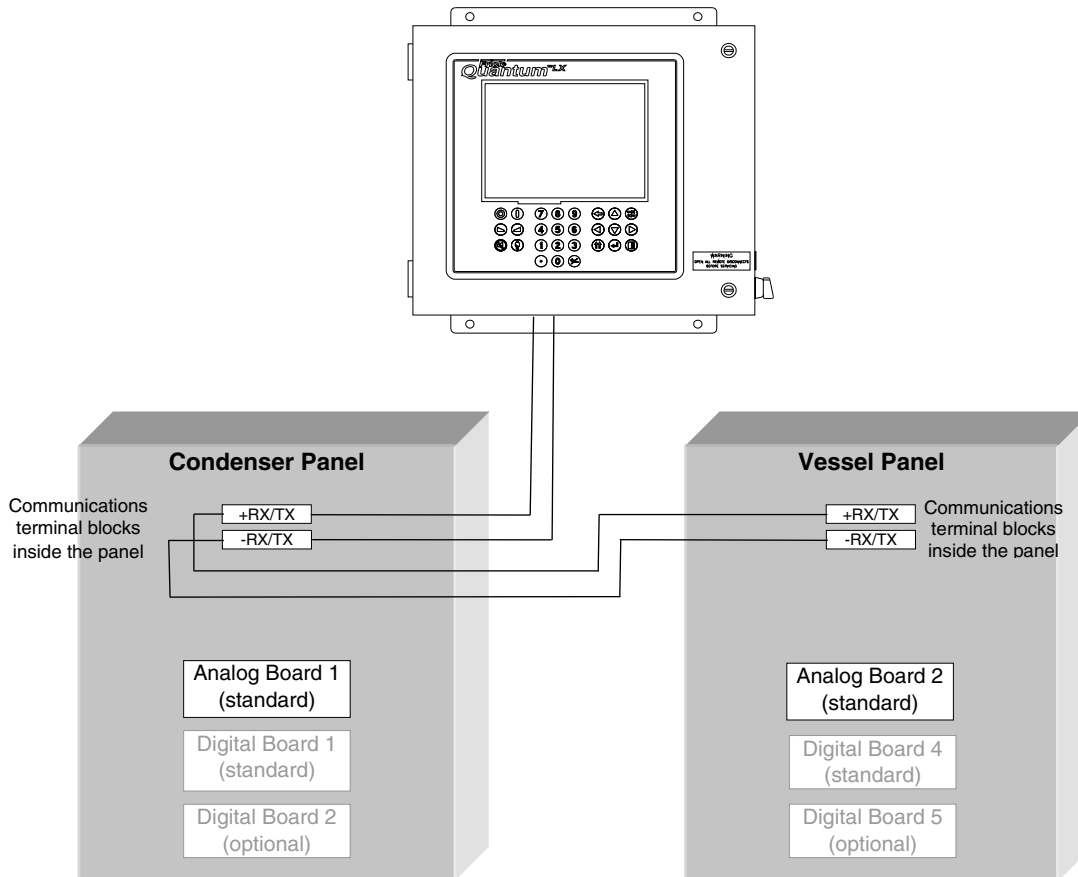

The above diagram represents the board layout, as well as a possible communications daisy-chain scheme.

SERVICE – Communications Loop-Back Test

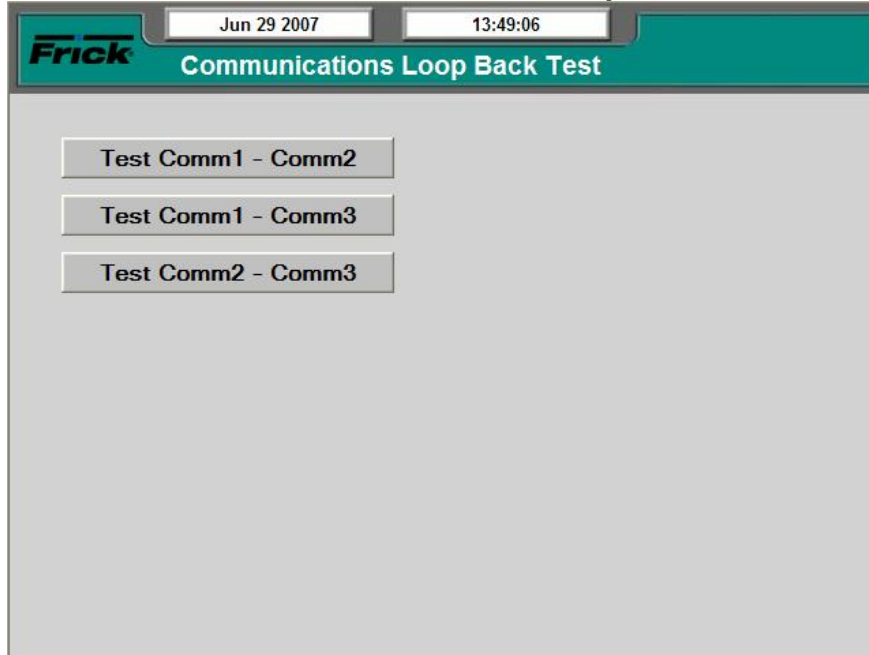

SCREEN NAME: *Service – Communications Loop Back Test.*



DESCRIPTION: This screen allows the user to test the integrity of each of the communications channels, by using a Loop-Back cable.

Refer to the Condenser/Vessel Communications Manual (S90-560 CS) for specific information about this test.

SERVICE – *Diagnostics*

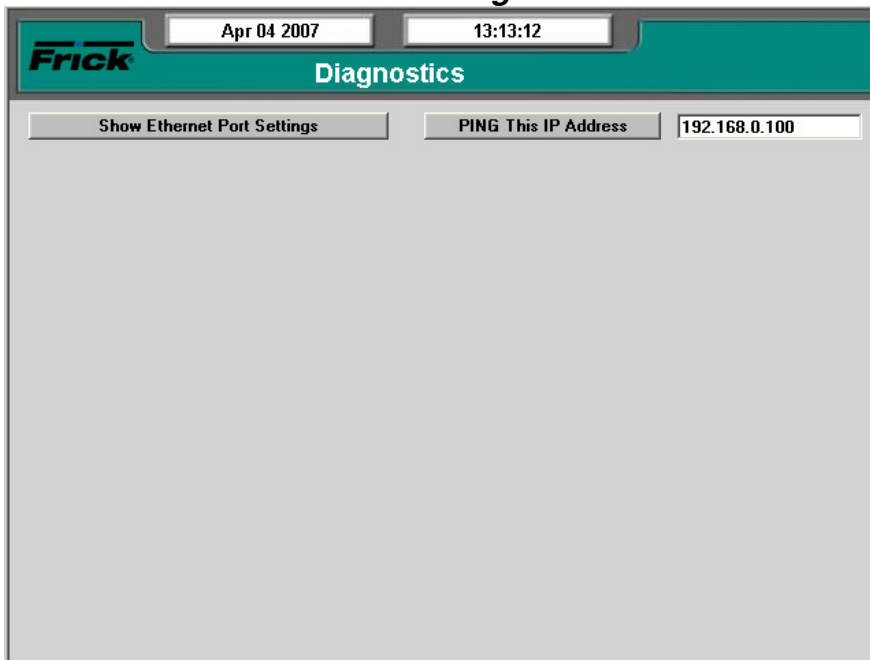

SCREEN NAME: *Analog I/O.*



DESCRIPTION: The Diagnostics screen has been provided as a way for the user to test the Ethernet connection.

Refer to the Condenser/Vessel Communications manual (S90-560 CS) for further information on this screen.

SERVICE – Software Maintenance

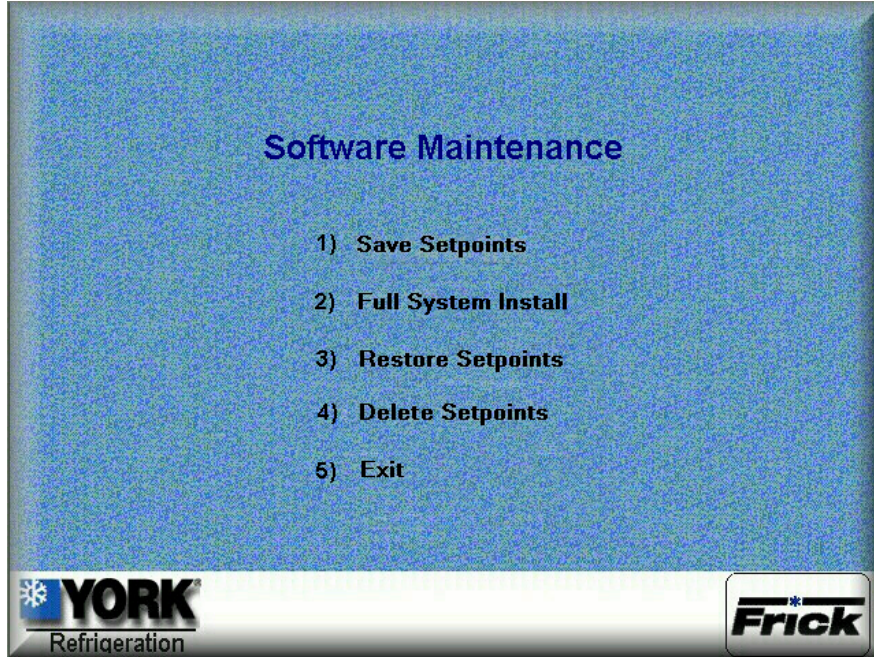

SCREEN NAME: *Software Maintenance.*

ACCESSING: → Service... → Software Maintenance

DESCRIPTION: This screen allows the technician to perform system software maintenance.

The following selections have been provided:

- 1) **Save Setpoints** - Use this option to save all setpoints and custom text to a USB device as a form of backup):
 - Ensure that all setpoint values have been documented as a safety precaution Install a USB device into the provide connection on the Quantum™.
 - Press the [1] button.
 - The software program will read the USB device, and the following dialog box will appear:

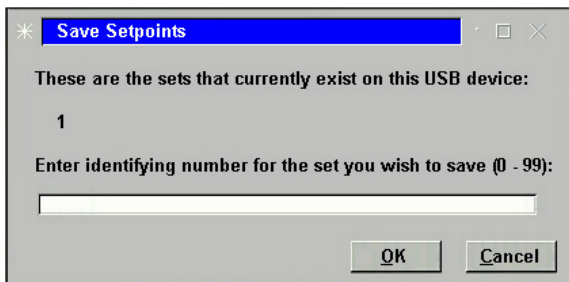

- Any numerals that appear on the center line of this box, will represent units that have already been saved (from 1 to 99). If no units have yet been saved, the center line will be blank.
- Enter a number on the keypad that corresponds to the unit number that you wish to save, then press [Enter]. If the unit

number has not been saved before, the setpoints will be saved to a file on the USB device (a progress bar will appear asking you to *Please Wait...* In the future, any time you try to write the setpoints to this number, you will be prompted with a message telling you that *the set number already exists – do you wish to overwrite it?* Answer by highlighting the Yes button, and pressing [Enter] if you do indeed wish to overwrite the values. If you enter a number that does not appear on the center line, no such warning will appear.

- After the file has been written or updated, the dialog boxes will disappear, and you can either exit, or continue with another function.

2) **Full System Install** - Use this option to install the entire operating system. This function will not overwrite any setpoints or custom text that may have previously been setup:

- Ensure that all setpoint values have been documented as a safety precaution.
- Press the [2] button.
- If a valid USB device with the operating system loaded on it is plugged in, the software will be loaded. If however, there is no USB device installed, or the device does not contain the operating software, the following dialog box will appear:

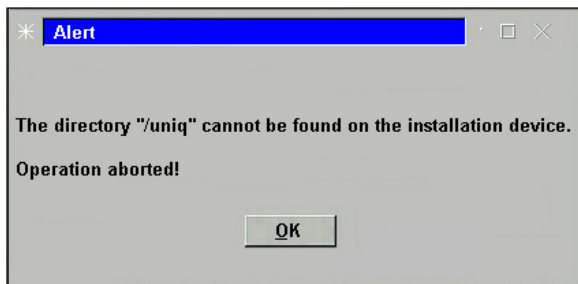

- If the above dialog box appears, you must insert a valid USB device that has the operating system loaded on it.

3) **Restore Setpoints** – Use this option to re-load previously saved setpoints and custom text to the Quantum™.

- Ensure that all setpoint values have been documented as a safety precaution. Install the previously saved setpoint USB device into the provided connection on the Qunatum™.
- Press the [3] button.
- The software program will read the USB device, and the following dialog box will appear:

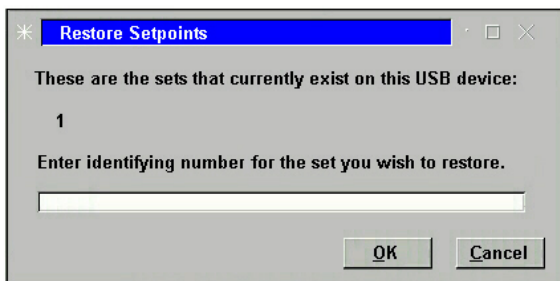

- Any numerals that appear on the center line of this box, will represent units that have already been saved (from 1 to 99). If no units have yet been saved, the center line will be blank and therefore there are no setpoints to restore.
- Enter a number on the keypad that corresponds to the unit number that you wish to restore, then press [Enter].
- A progress bar will appear asking you to *Please Wait...*

- After the file has been written or updated, the dialog boxes will disappear, and you can either exit, or continue with another function.

4) **Delete Setpoints** – Use this option to delete the setpoints and custom text for a particular unit.:

- Ensure that all setpoint values have been documented as a safety precaution. Install the previously saved setpoints USB device into the provided connection on the Qunatum™.
- Press the [4] button.
- The software program will read the USB device, and the following dialog box will appear:

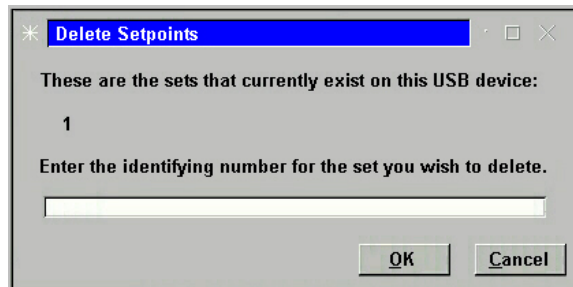

- Any numerals that appear on the center line of this box, will represent units that have already been saved (from 1 to 99). If no units have yet been saved, the center line will be blank, and therefore there are no setpoints to delete.
- Enter a number on the keypad that corresponds to the unit number that you wish to delete, highlight the *Ok* button, then press [Enter]. You will be prompted with a new dialog box which will ask you *OK to delete set number (1-99)?*
- Highlight the *Yes* button, and press [Enter]. The dialog box will be updated with a new message stating that *Set number (1-99) has been deleted!*
- Press [Enter] to return to the Software Maintenance menu.

5) **Exit** - Use this selection to leave this screen by pressing the [5] button, the panel will reboot and return to the **Operating Status** screen.

MISCELLANEOUS MAINTENANCE SCREENS

About

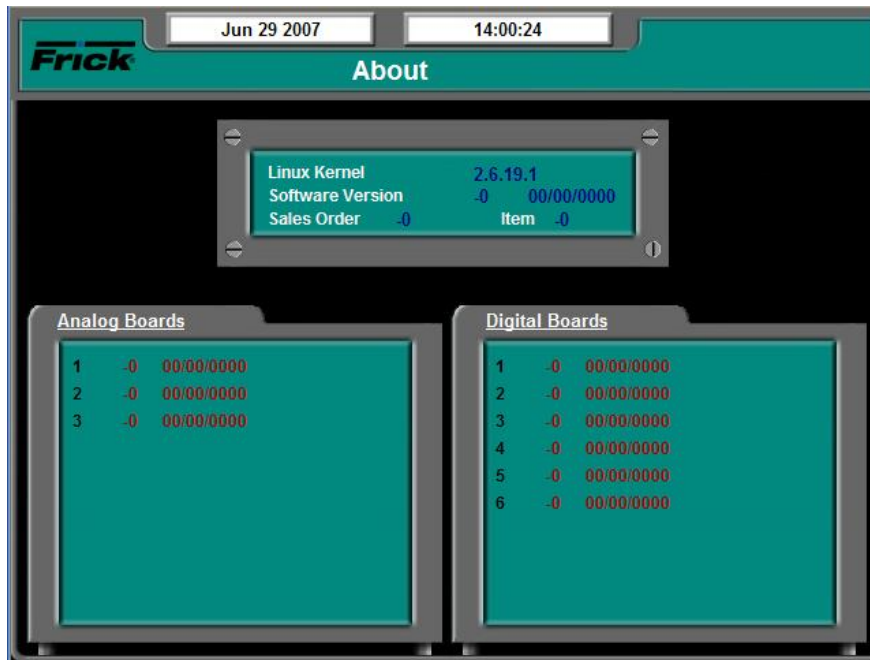

SCREEN NAME: *Sequencing*.

ACCESSING:  → **About**

DESCRIPTION: The **About** screen shows the Analog and Digital boards that have been detected. If a board has lost communications, a shutdown will be issued. All outputs are turned off on a Digital Board that has lost communications. All inputs will get set to their minimum value range on an Analog Board that has lost communications. A loss of communications to an analog board should result in sensor fault shutdown message that is associated with the sensors on that board. If the RX LED on the I/O board is blinking but the board was not detected on the **About** screen, or an I/O Comm failure occurs, check the address of the board.

TROUBLESHOOTING A PROBLEM THAT APPEARS UNEXPLAINABLE

When there is a problem that makes no sense due to unexplainable things happening, check the following:

- Is the panel powered by an isolating power source such as a control transformer?
- Is the panel powered from a lighting or utility panel?
- Has the unit ever worked properly?
- If the unit used to work properly, try to determine when the problem first showed up.
- It is important to know if the problem occurs randomly, frequently, or all the time.
- Check what the temperature is at the unit location. Is it very hot or very cold?
- Make sure that a motor is not blowing exhaust air on the control panel.
- If it just started to act up, then check if there was recently a severe lightning storm, fire, flood, or a plant accident. If any of the following conditions are possible, then check for it:
 - Has any water, refrigerant, or oil leaked into the panel or conduit?
 - If it just started to act up, then check if anything was recently changed in the system (i.e. software or hardware.)
 - If it just started to act up, then check if any service was recently done to the unit or its electrical system?
 - If there is communication wiring connecting the panel to another panel or device, then check the following:
 - If the Quantum™ is unexplainably shutting down, try disconnecting the communications cable to see if the problem goes away.
 - Check if the communications cable shields are tied to machine ground at only one location. For a PLC or Opto22 based system, the shield should normally be tied only at the PLC or Opto22 panel.
 - Check that you are using the Frick® recommended communications cable. See manual to match proper cable with type of communications (i.e., RS-422, RS-232, RS-485, or some other type of factory communication bus system.)
- If this is an older plant, has the plant wiring been brought up to code?
- Is power wiring mixed with control wiring?
- Is power wiring mixed with sensor wiring?
- Is power wiring mixed with communications wiring?
- Ensure that pressure transducers are properly grounded. The two types of transducers you may

have are as follows: an older type has an 8 to 10 inch 3-conductor pigtail coming out of the transducer. This type will have the attaching cable's shield cut off and insulated at the transducer end. The shield is then tied to a panel ground terminal in the panel. The newer type has the cable as an integral part of the housing and has the shield crimped to the case at the transducer end. This type of transducer has the cable's shield cut off and insulated in the control panel.

- Ensure that temperature transducers are properly grounded. The temperature probes usually have two short wires coming out of the sensor, and are tied to a shielded cable at the thermal well head. The shield is insulated at the temperature probe and grounded at the panel end.
- Check if one of the temperature probes has a signal wire shorted to machine ground. To do this, first pull the orange plug from the appropriate channel of the Analog board and then use a DVM and check each white wire to machine ground and each black wire to machine ground.
- Check that all inductive loads (i.e. Coils, Solenoids, or Relays, etc.) connected to the I/O output modules have surge suppressers across them, preferably at the devices and not at the panel end.
- Make sure that you have a continuous ground back to the power source. The ground connection must be aluminum or copper. A conduit ground will not work.
- Ensure that there is no AC wiring lying next to any printed circuit boards.
- Unexplainable unit failures are usually indicative of noise due to wiring problems (i.e. incorrect earth grounds, mixed power and control wiring, unsuppressed coils, etc)
- If the unit is unexplainably shutting down, check if the machine shares power with something else.

ERASING THE SYSTEM SETPOINTS

In the event it becomes necessary to erase the systems setpoints, use the following procedure:

1. Ensure that the existing setpoints are documented if possible.
2. Power the controller down.
3. Locate the processor board (located in the Quantum™ LX Control Panel).
4. On the processor board (the larger of the two boards), locate and temporarily remove LK11.
5. Power the unit up.
6. Wait for one minute to allow the processor to fully boot.
7. Power the unit down.
8. Replace LK11.
9. Power back up.

WIRING DIAGRAMS

Condenser Panel Digital Board 1 Inputs/Outputs (Page 1 of 3)

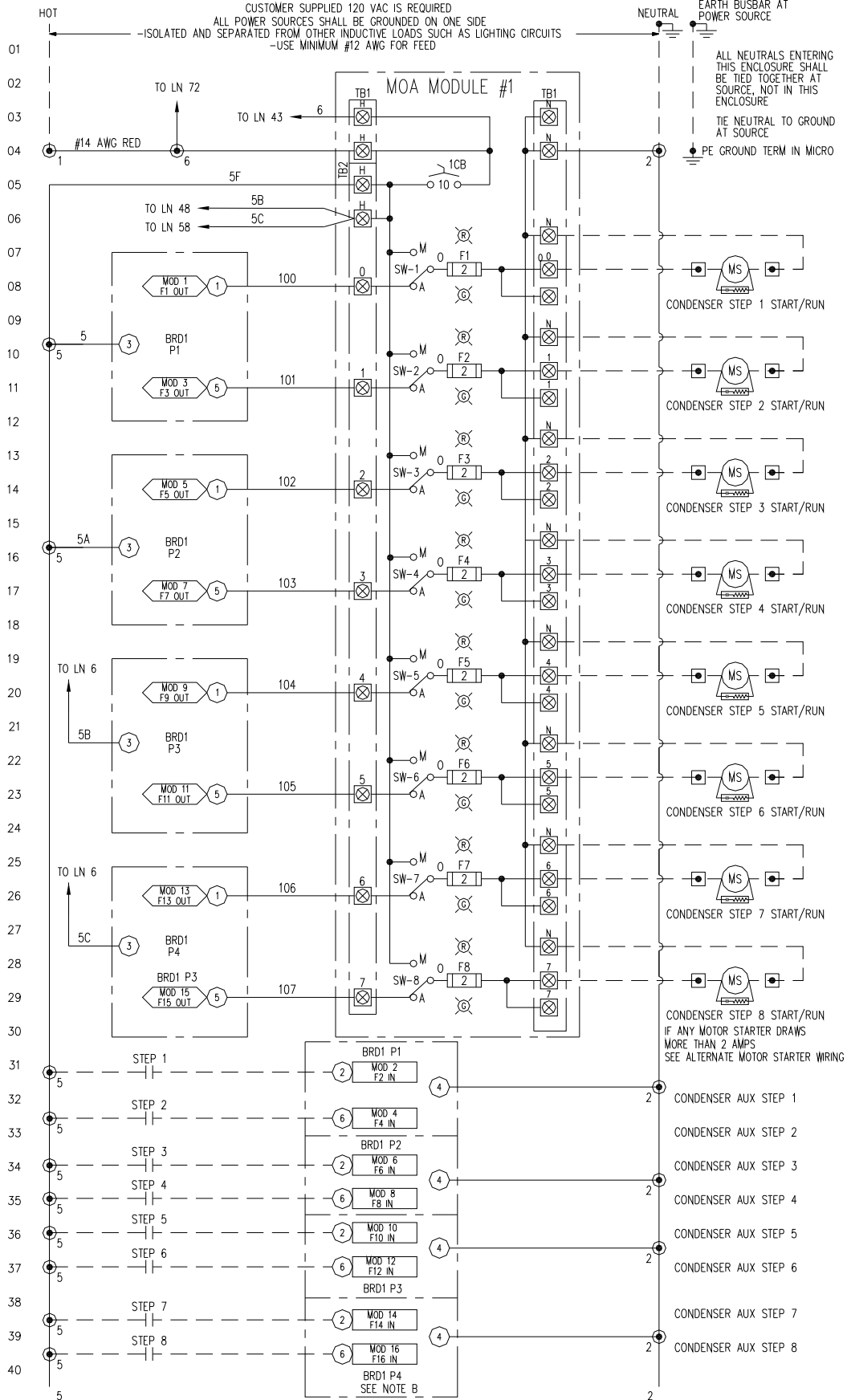

Condenser Panel Digital Board 1 Inputs/Outputs (Page 2 of 3)

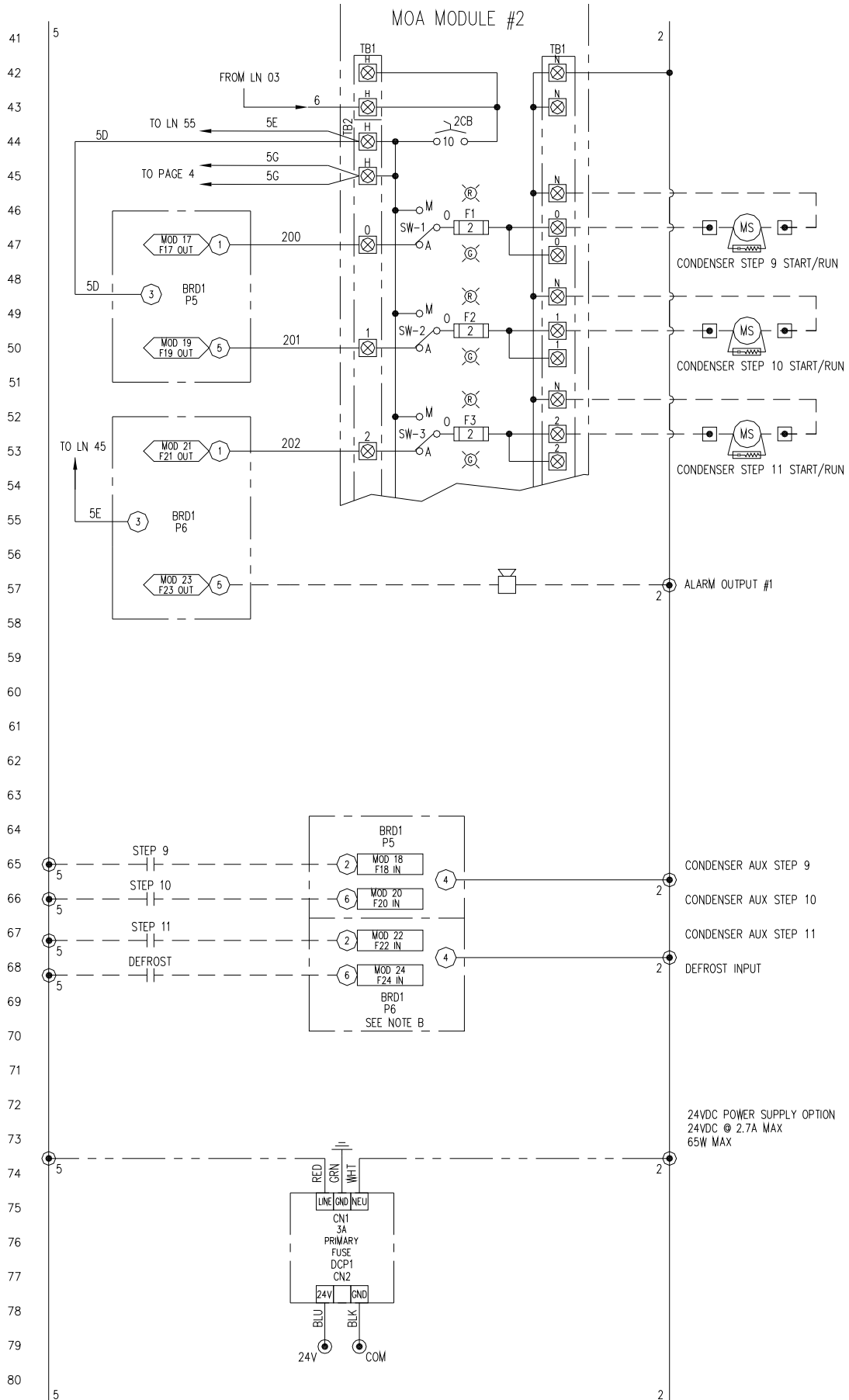

Condenser Panel Digital Board 1 Inputs/Outputs (Page 3 of 3)

NOTE A:

A SURGE SUPPRESSOR OR MOV TO BE INSTALLED ACROSS ALL INDUCTIVE LOADS IN CONTROL CENTER.

NOTE B:

ALL INPUT MODULE VOLTAGE RATINGS MUST MATCH THE INCOMING POWER



SURGE SUPPRESSOR

SUPPRESSOR SPECIFICATIONS:

RC NETWORK CONSISTING OF A .1 MFD CAPACITOR, 600

VDC IN SERIES WITH A 47 OHM RESISTOR.

USE ELECTROCUBE #RG2031-3-6 OR EQUAL.



VARISTOR

METAL OXIDE VARISTOR (MOV) SPECIFICATIONS:

GE #V130LA10A OR EQUAL FOR 120 VOLTS

ALTERNATE FAN WIRING

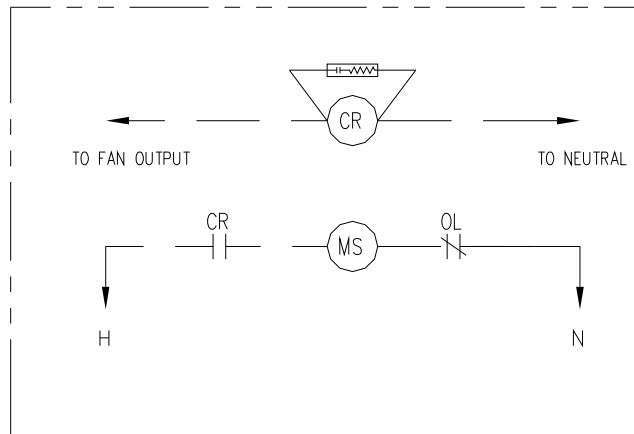

— — WIRING BY OTHERS- ALL WIRING ENTERING CONTROL CENTER (INCLUDING GROUND & NEUTRAL) TO BE #14 AWG STRANDED WIRES UNLESS SPECIFIED OTHERWISE.

⊙ TERMINALS ON BACKPLATE

● TERMINALS IN MOTOR STARTER

NO THREE PHASE WIRING SHALL ENTER OR LEAVE PANEL OR BE RUN IN SAME CONDUIT AS ANY CONTROL WIRING ENTERING OR LEAVING PANEL

NO SINGLE PHASE OVER 300 VOLTS SHALL ENTER OR LEAVE PANEL

ALL WIRING TO BE #16 AWG STRANDED WIRE UNLESS SPECIFIED OTHERWISE.

ALL NEUTRAL (EXP: 2 & 2A) WIRING TO BE WHITE UNLESS NOTED OTHERWISE

Condenser Panel Optional Digital Board 2 Inputs/Outputs (Page 1 of 3)

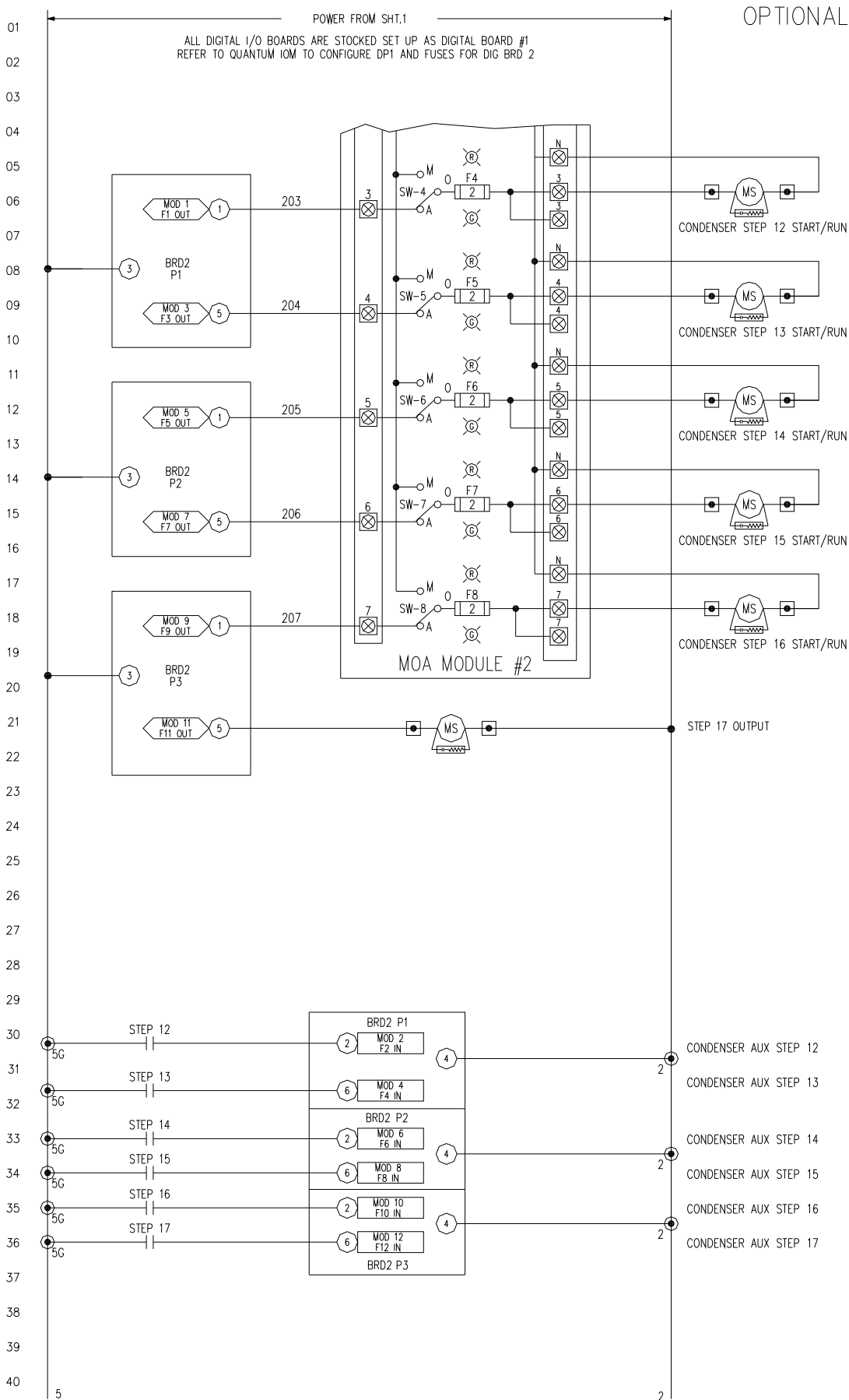

Condenser Panel Optional Digital Board 2 Inputs/Outputs (Page 2 of 3)

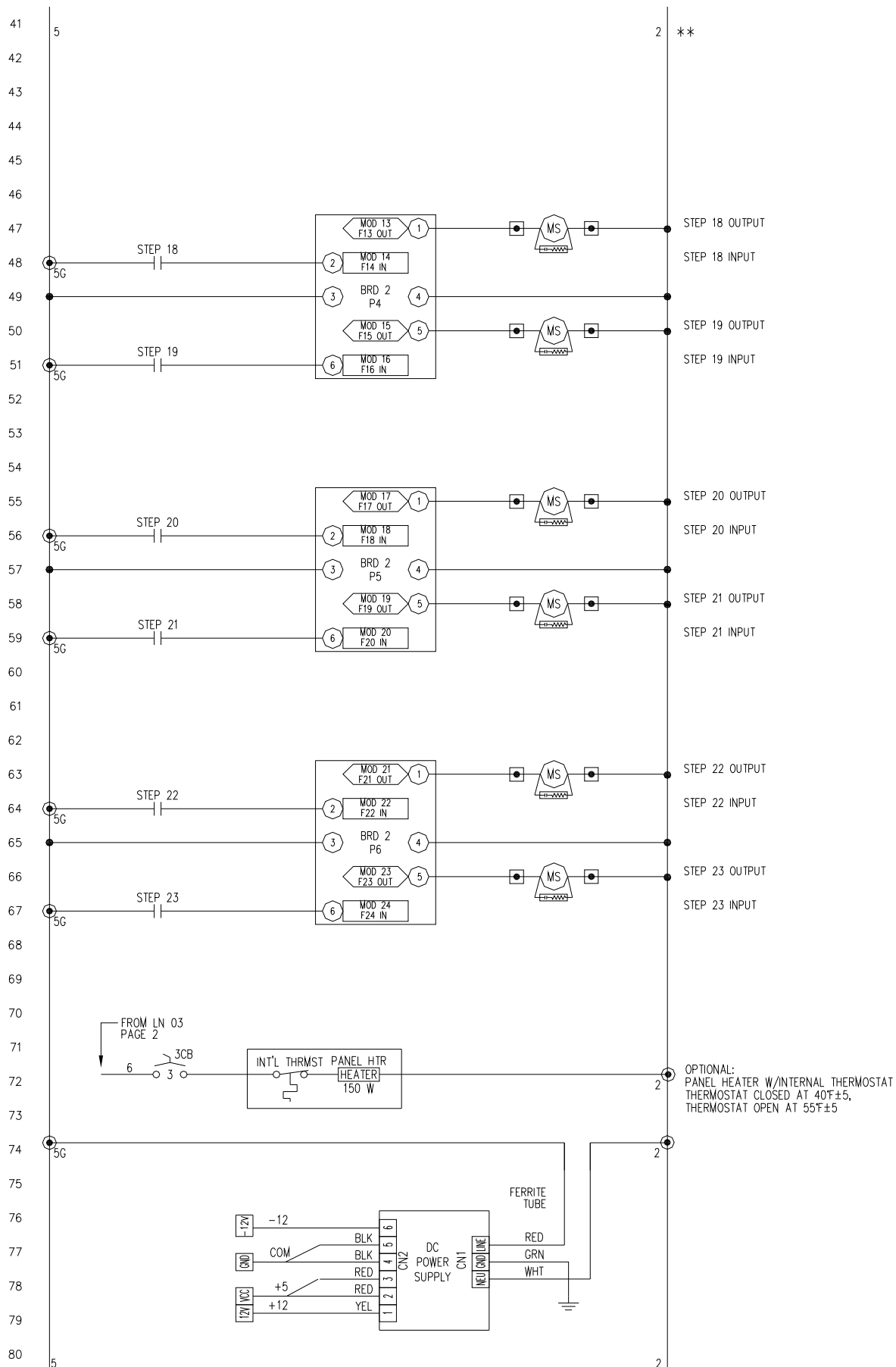

Condenser Panel Optional Digital Board 2 Inputs/Outputs (Page 3 of 3)

NOTE A:

A SURGE SUPPRESSOR OR MOV TO BE INSTALLED ACROSS ALL INDUCTIVE LOADS IN CONTROL CENTER.

 SURGE SUPPRESSOR

SUPPRESSOR SPECIFICATIONS:

RC NETWORK CONSISTING OF A .1 MFD CAPACITOR, 600 VDC IN SERIES WITH A 47 OHM RESISTOR.

USE ELECTROCUBE #RG2031-3-6 OR EQUAL.

 VARISTOR

METAL OXIDE VARISTOR (MOV) SPECIFICATIONS:

GE #V130LA10A OR EQUAL FOR 115 VOLTS

GE #V250LA10A OR EQUAL FOR 230 VOLTS

————— INDICATES DEVICES SUPPLIED ONLY WHEN OPTIONAL OR REQUIRED

————— WIRING BY OTHERS— ALL WIRING ENTERING CONTROL CENTER (INCLUDING GROUND & NEUTRAL) TO BE #14 AWG STRANDED WIRES UNLESS SPECIFIED OTHERWISE.

 REPRESENTS STARTER TERMINALS

 TERMINALS IN CONTROL CENTER

NO THREE PHASE WIRING SHALL ENTER OR LEAVE QUANTUM PANEL OR BE RUN IN SAME CONDUIT AS ANY QUANTUM CONTROL WIRING ENTERING OR LEAVING MICRO PANEL

NO SINGLE PHASE OVER 300 VOLTS SHALL ENTER OR LEAVE QUANTUM PANEL

ALL CONTROL CENTER WIRING TO BE #16 AWG STRANDED WIRE UNLESS SPECIFIED OTHERWISE.

Condenser Panel Analog Board Inputs/Outputs (Page 1 of 3)

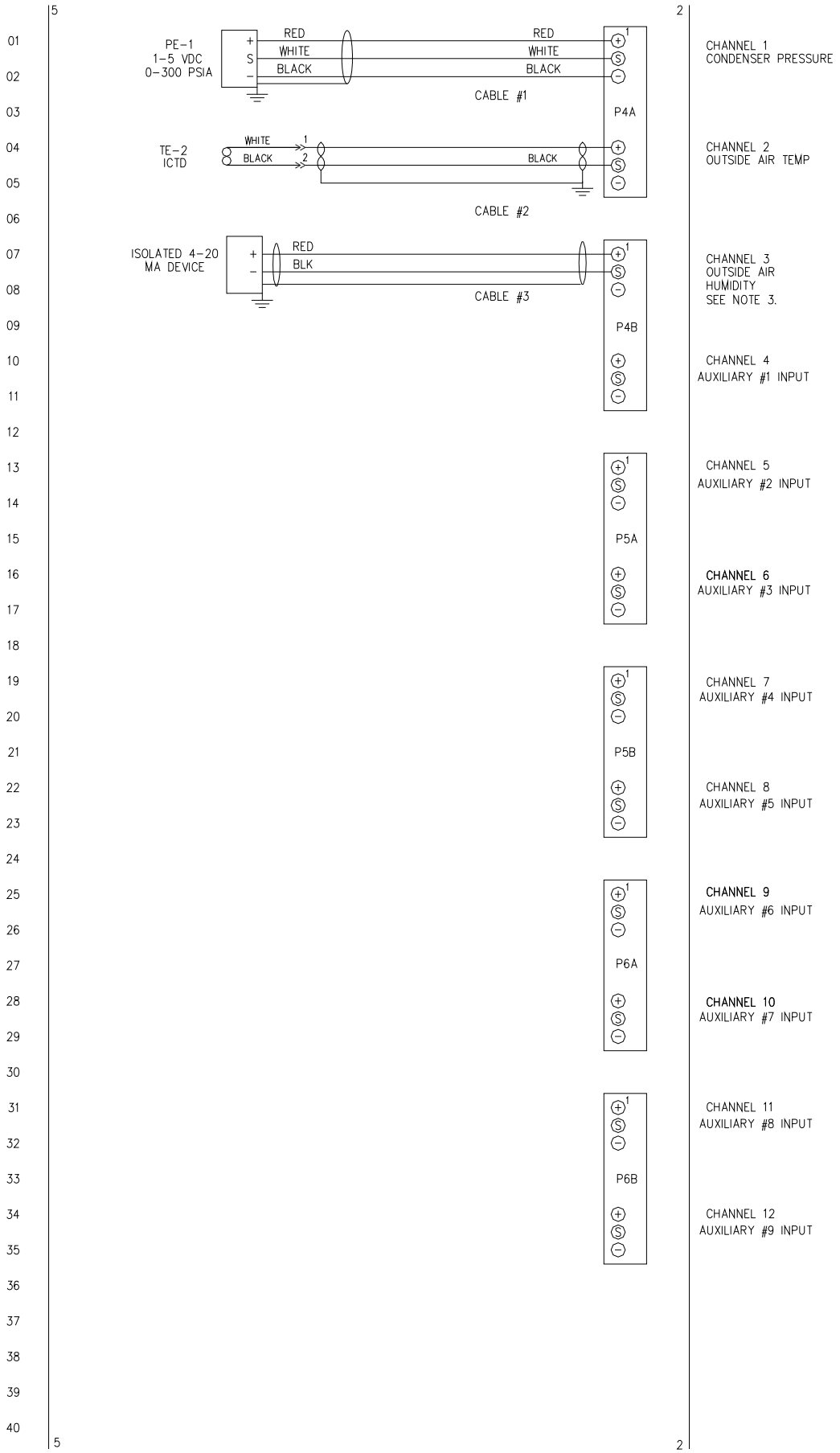

Condenser Panel Analog Board Inputs/Outputs (Page 2 of 3)

5
41
42
43
44
45
46
47
48
49
50
51
52
53
54
55
56
57
58
59
60
61
62
63
64
65
66
67
68
69
70
71
72
73
74
75
76
77
78
79
80

2
CHANNEL 13
AUXILIARY #10 INPU

CHANNEL 14
NOT USED

CHANNEL 15
NOT USED

CHANNEL 16
NOT USED
(NOT ICTD)

NOT USED

NOT USED
NOT USED
NOT USED
NOT USED

CHANNEL 1
VARIABLE SPEED
FAN #1
4-20 MA

CHANNEL 2
VARIABLE SPEED
FAN #2
4-20 MA

CHANNEL 3
VARIABLE SPEED
FAN #3
4-20 MA

CHANNEL 4
VARIABLE SPEED
FAN #4
4-20 MA

CHANNEL 5
VARIABLE SPEED
FAN #5
4-20 MA

CHANNEL 6
VARIABLE SPEED
FAN #6
4-20 MA

CHANNEL 7
VARIABLE SPEED
FAN #7
4-20 MA

CHANNEL 8
VARIABLE SPEED
FAN #8
4-20 MA

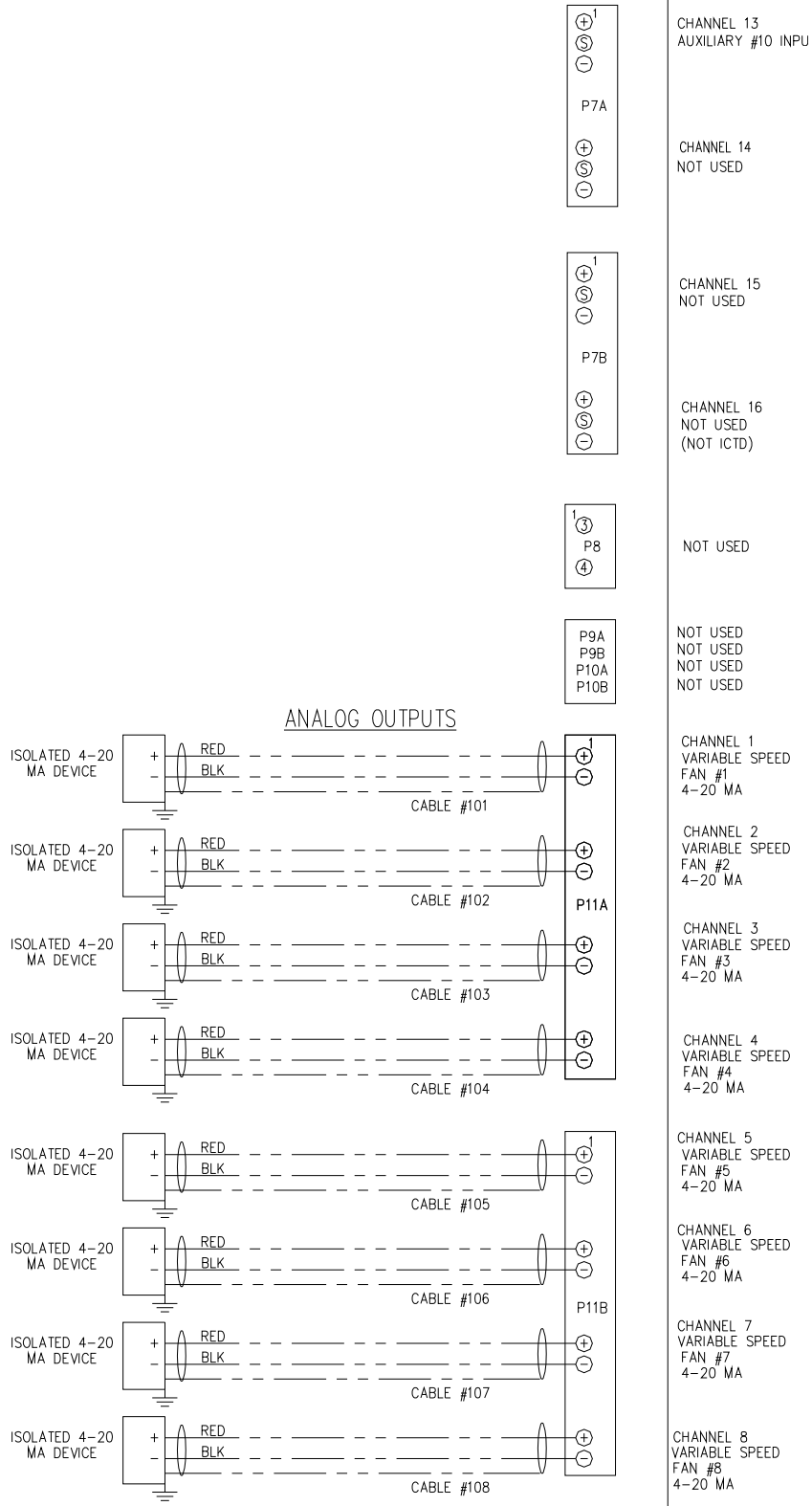

Condenser Panel Analog Board Inputs/Outputs (Page 3 of 3)

NOTE 1A:

ALL ANALOG LOW VOLTAGE WIRING TO BE RUN IN SEPARATE CONDUIT FROM ALL OTHER WIRING. ALL DRAIN WIRES TO BE INSULATED EITHER TOGETHER OR SEPARATELY WITHIN 2" OR CLOSER OF TERMINATION IF NOT CONFINED OTHERWISE.

NOTE 2A:

TEMPERATURE WIRING SPECIFICATIONS:

MINIMUM CABLE SIZE FOR SENSOR WIRING TO BE 22 AWG, TWISTED PAIR – BELDEN #8762 OR EQUAL 20/2 TWISTED PAIR SUGGESTED IF CABLE HAS A DRAIN WIRE, GROUND DRAIN WIRE AT ONE END ONLY AND INSULATE OTHER END. 2000 FT. MAX. DISTANCE

NOTE 3:

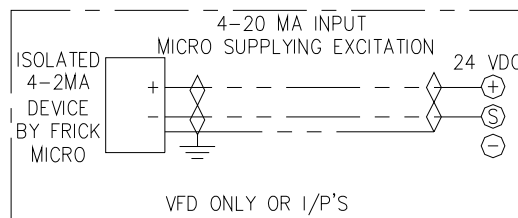
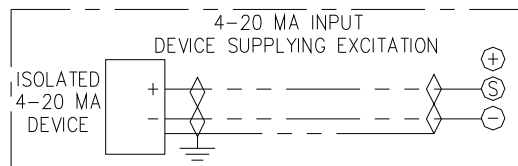
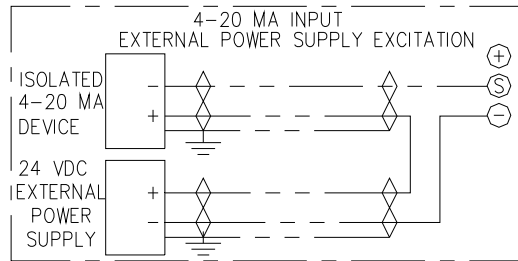

Vessel Panel Digital Board 1 Inputs/Outputs (Page 1 of 3)

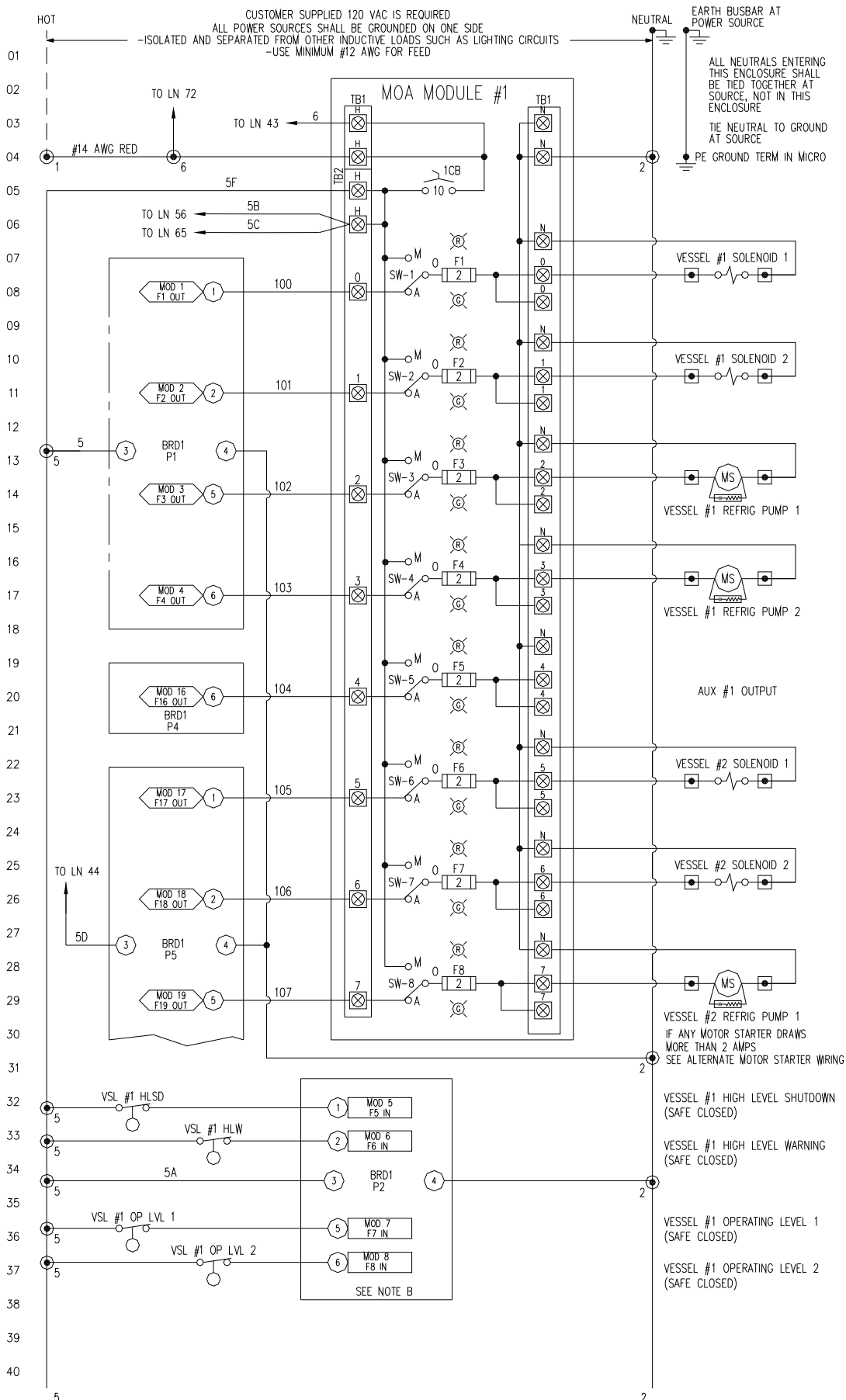

Vessel Panel Digital Board 1 Inputs/Outputs (Page 2 of 3)

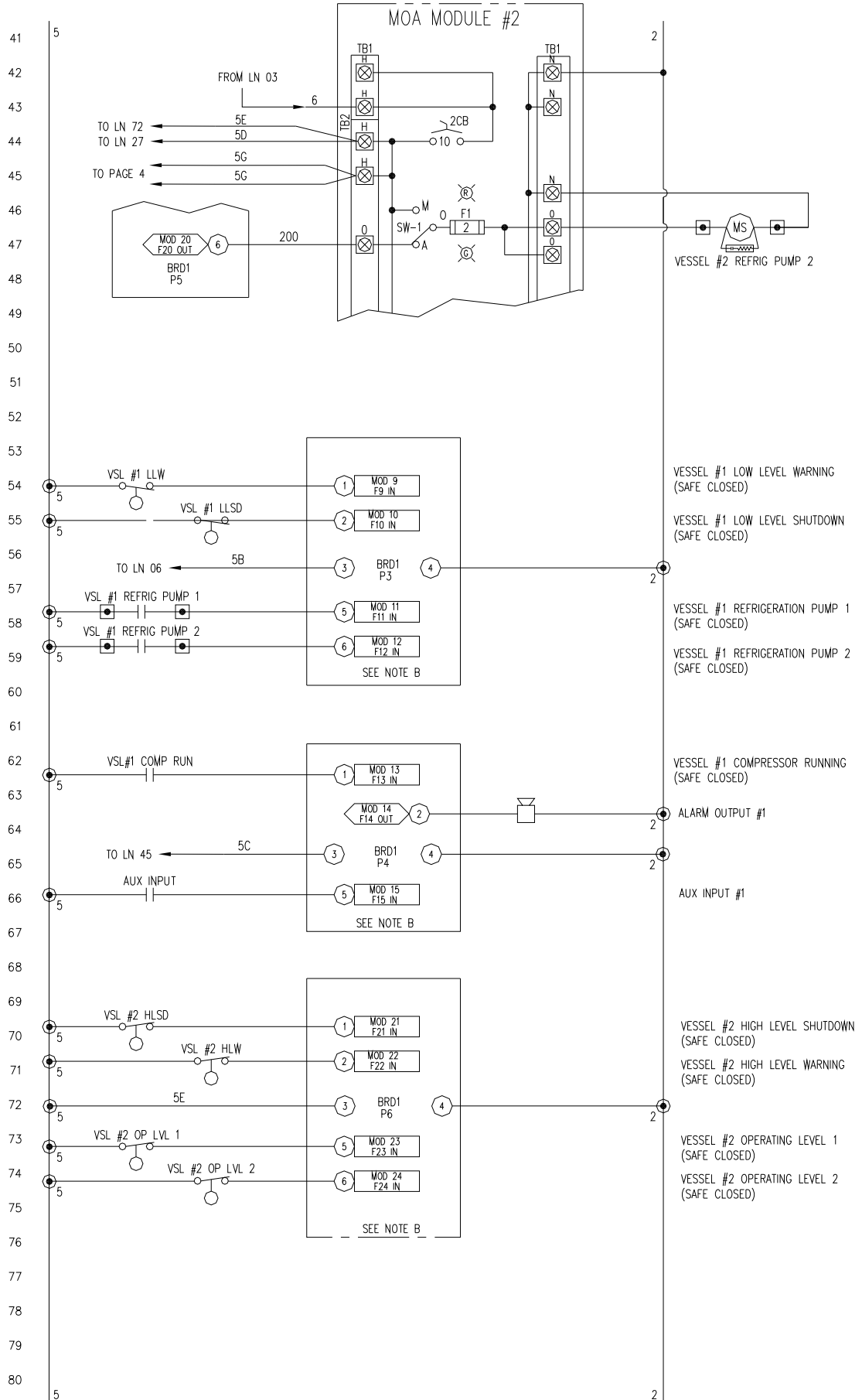

Vessel Panel Digital Board 1 Inputs/Outputs (Page 3 of 3)
Notes

NOTE A:

A SURGE SUPPRESSOR OR MOV TO BE INSTALLED ACROSS ALL INDUCTIVE LOADS IN CONTROL CENTER.

NOTE B:

ALL INPUT MODULE VOLTAGE RATINGS MUST MATCH THE INCOMING POWER



SURGE SUPPRESSOR

SUPPRESSOR SPECIFICATIONS:

RC NETWORK CONSISTING OF A .1 MFD CAPACITOR, 600

VDC IN SERIES WITH A 47 OHM RESISTOR.

USE ELECTROCUBE #RG2031-3-6 OR EQUAL.



VARISTOR

METAL OXIDE VARISTOR (MOV) SPECIFICATIONS:

GE #V130LA10A OR EQUAL FOR 120 VOLTS

ALTERNATE FAN WIRING

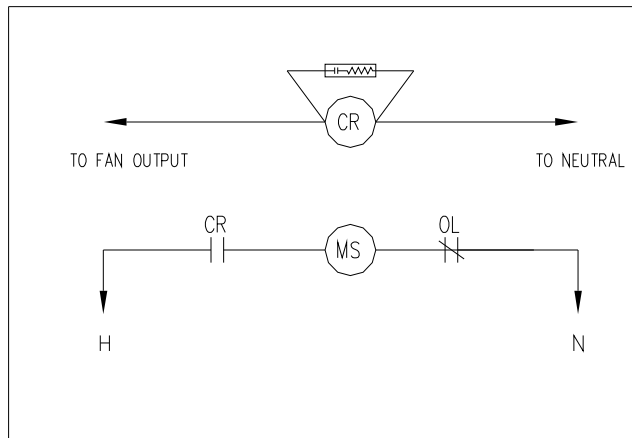

————— WIRING BY OTHERS— ALL WIRING ENTERING CONTROL CENTER (INCLUDING GROUND & NEUTRAL) TO BE #14 AWG STRANDED WIRES UNLESS SPECIFIED OTHERWISE.

⊖ TERMINALS ON BACKPLATE

⊙ TERMINALS IN MOTOR STARTER

NO THREE PHASE WIRING SHALL ENTER OR LEAVE PANEL OR BE RUN IN SAME CONDUIT AS ANY CONTROL WIRING ENTERING OR LEAVING PANEL

NO SINGLE PHASE OVER 300 VOLTS SHALL ENTER OR LEAVE PANEL

ALL WIRING TO BE #16 AWG STRANDED WIRE UNLESS SPECIFIED OTHERWISE.

ALL NEUTRAL (EXP: 2 & 2A) WIRING TO BE WHITE UNLESS NOTED OTHERWISE

Vessel Panel Optional Digital Board 2 Inputs/Outputs (Page 1 of 3)

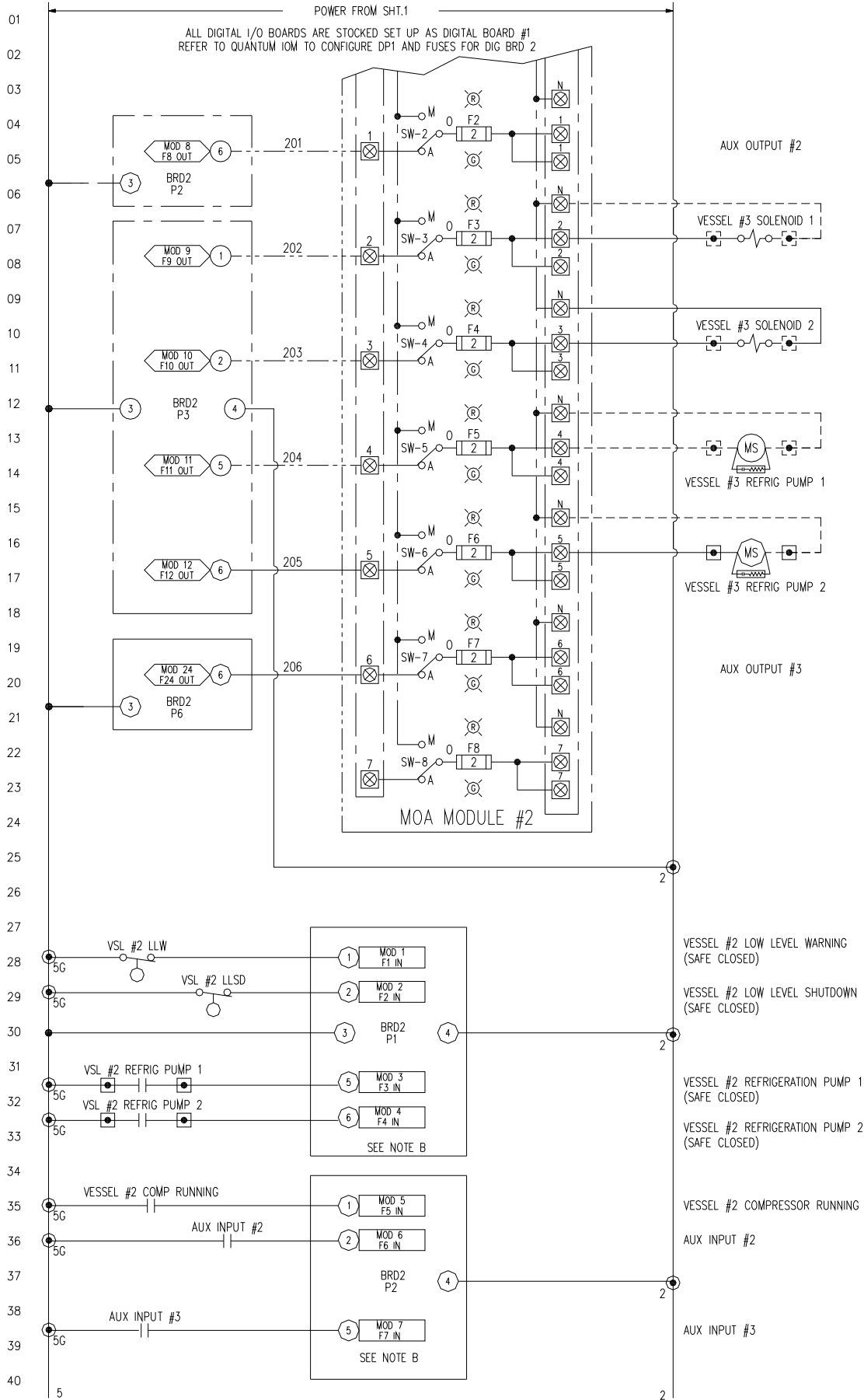

Vessel Panel Optional Digital Board 2 Inputs/Outputs (Page 2 of 3)

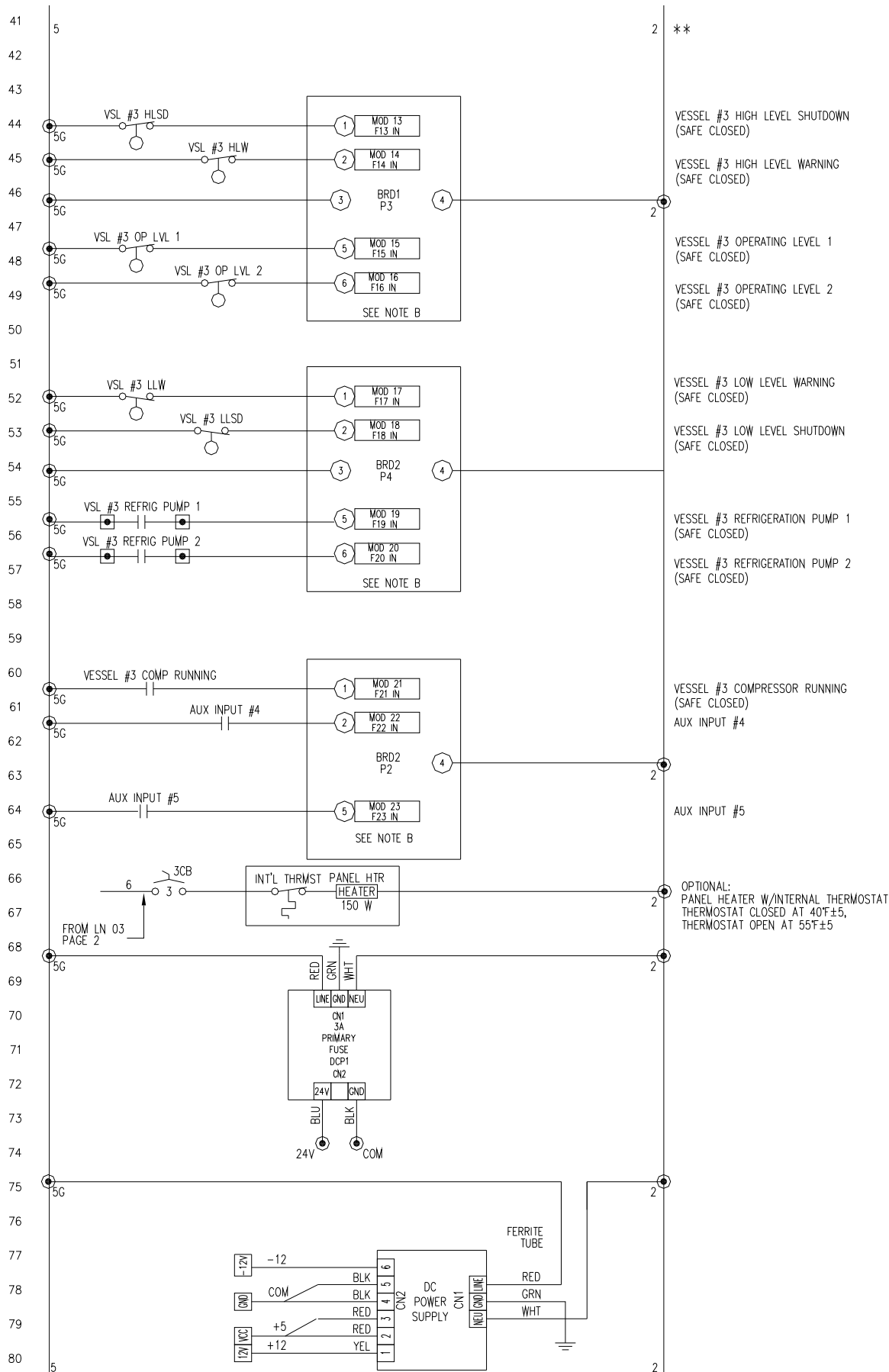

Vessel Panel Optional Digital Board 2 Inputs/Outputs (Page 3 of 3)NOTE A:

A SURGE SUPPRESSOR OR MOV TO BE INSTALLED ACROSS ALL INDUCTIVE LOADS IN CONTROL CENTER.

 SURGE SUPPRESSOR

SUPPRESSOR SPECIFICATIONS:

RC NETWORK CONSISTING OF A .1 MFD CAPACITOR, 600 VDC IN SERIES WITH A 47 OHM RESISTOR.

USE ELECTROCUBE #RG2031-3-6 OR EQUAL.

 VARISTOR

METAL OXIDE VARISTOR (MOV) SPECIFICATIONS:

GE #V130LA10A OR EQUAL FOR 115 VOLTS

GE #V250LA10A OR EQUAL FOR 230 VOLTS

———— INDICATES DEVICES SUPPLIED ONLY
WHEN OPTIONAL OR REQUIRED

———— WIRING BY OTHERS— ALL WIRING ENTERING CONTROL
CENTER (INCLUDING GROUND & NEUTRAL) TO BE #14
AWG STRANDED WIRES UNLESS SPECIFIED OTHERWISE.

 REPRESENTS STARTER TERMINALS

 TERMINALS IN CONTROL CENTER

NO THREE PHASE WIRING SHALL ENTER OR LEAVE QUANTUM PANEL
OR BE RUN IN SAME CONDUIT AS ANY QUANTUM CONTROL WIRING
ENTERING OR LEAVING MICRO PANEL

NO SINGLE PHASE OVER 300 VOLTS SHALL ENTER OR LEAVE QUANTUM PANEL

ALL CONTROL CENTER WIRING TO BE #16 AWG
STRANDED WIRE UNLESS SPECIFIED OTHERWISE.

Vessel Panel Analog Inputs/Outputs (Page 1 of 3)

01
02
03
04
05
06
07
08
09
10
11
12
13
14
15
16
17
18
19
20
21
22
23
24
25
26
27
28
29
30
31
32
33
34
35
36
37
38
39
40

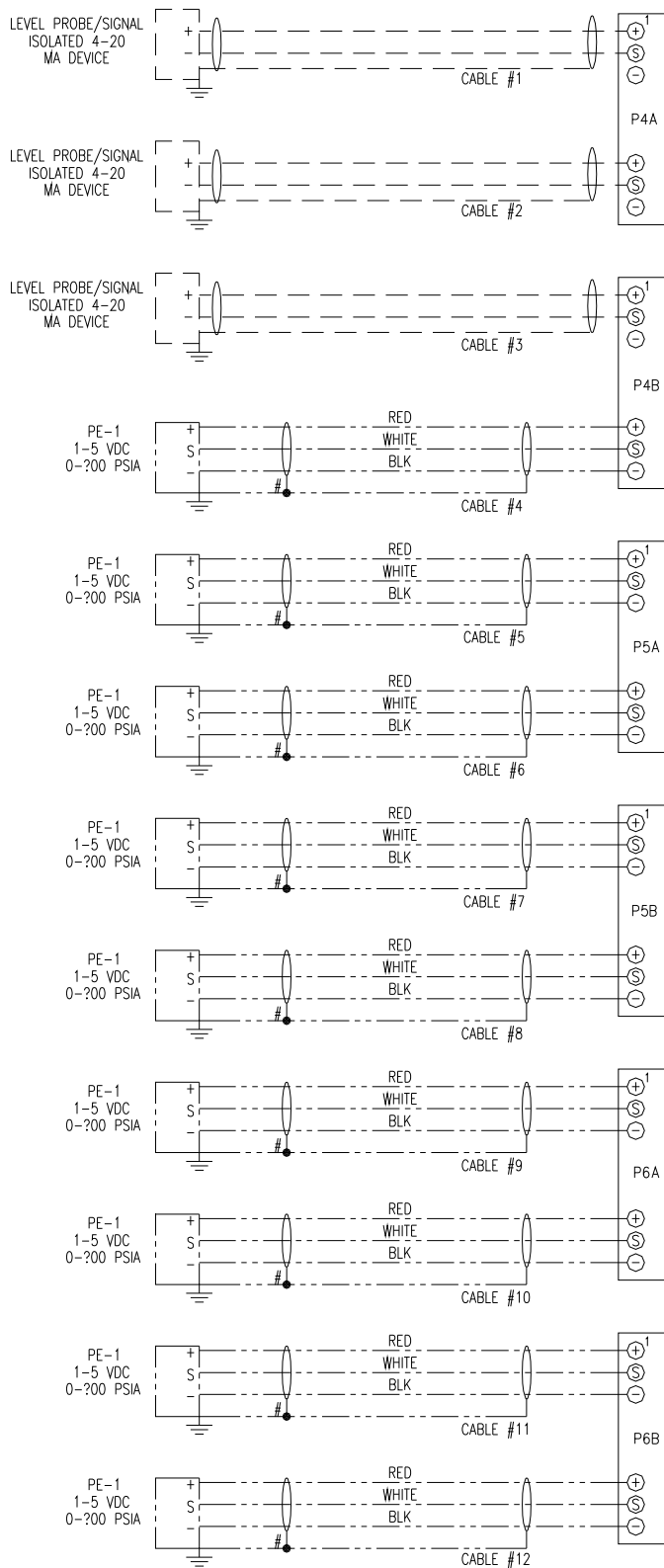

2

CHANNEL 1
VESSEL #1 LEVEL

CHANNEL 2
VESSEL #2 LEVEL

CHANNEL 3
VESSEL #3 LEVEL

CHANNEL 4
VESSEL #1 PRESSURE

CHANNEL 5
VESSEL #2 PRESSURE

CHANNEL 6
VESSEL #3 PRESSURE

CHANNEL 7
VESSEL #1 / PUMP #1
HIGH SIDE PRESSURE

CHANNEL 8
VESSEL #2 / PUMP #1
HIGH SIDE PRESSURE

CHANNEL 9
VESSEL #3 / PUMP #1
HIGH SIDE PRESSURE

CHANNEL 10
VESSEL #1 / PUMP #1
LOW SIDE PRESSURE

CHANNEL 11
VESSEL #2 / PUMP #1
LOW SIDE PRESSURE

CHANNEL 12
VESSEL #3 / PUMP #1
LOW SIDE PRESSURE

Vessel Panel Analog Inputs/Outputs (Page 3 of 3)
Notes

NOTE 1A:

ALL ANALOG LOW VOLTAGE WIRING TO BE RUN IN SEPARATE CONDUIT FROM ALL OTHER WIRING. ALL DRAIN WIRES TO BE INSULATED EITHER TOGETHER OR SEPARATELY WITHIN 2" OR CLOSER OF TERMINATION IF NOT CONFINED OTHERWISE.

NOTE 2A:

TEMPERATURE WIRING SPECIFICATIONS:

MINIMUM CABLE SIZE FOR SENSOR WIRING TO BE 22 AWG, TWISTED PAIR – BELDEN #8762 OR EQUAL 20/2 TWISTED PAIR SUGGESTED IF CABLE HAS A DRAIN WIRE, GROUND DRAIN WIRE AT ONE END ONLY AND INSULATE OTHER END. 2000 FT. MAX. DISTANCE

NOTE 3:

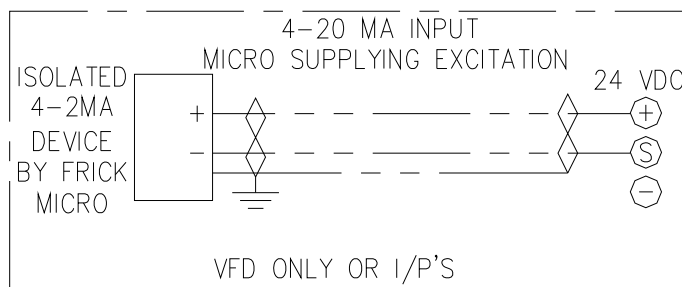
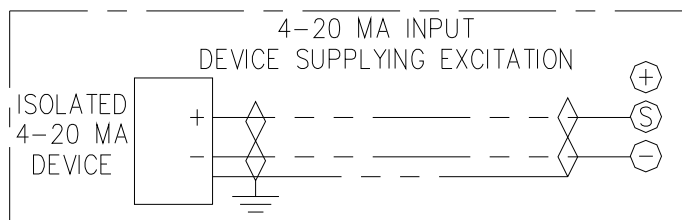
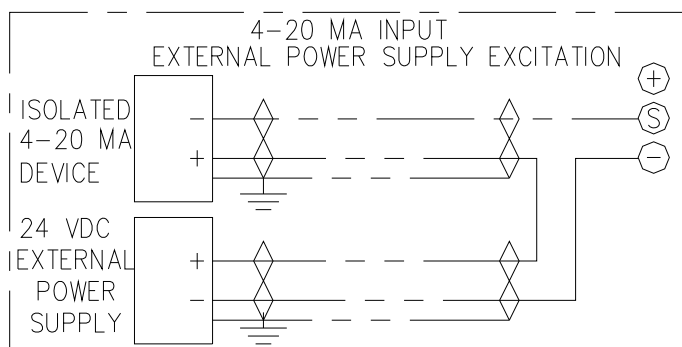

QUANTUM™ LX CONDENSER/VESSEL REPLACEMENT PARTS (Page 1 of 2)

Condenser/Vessel Quantum™ LX Operator Interface Panel

Part Number	Description
	Circuit Breakers
639A0206H03	3 Amp circuit breaker <i>(optional panel heater)</i>
	Control Power
639A0185H10	2-Pos. Selector Switch <i>(Control Power)</i>
639A0185H30	Latch, 3 Across <i>(Attaches contact block to switch mechanism)</i>
639A0185H36	Normally Open Contact Block <i>(for Control Power Switch)</i>
	Display
333Q0001582	CCFT inverter
649B0913H01	Display Harness, 10 inch <i>(Quantum 4, processor mounted on display plate)</i>
649D4824H01	Display Harness, 21 inch <i>(Quantum 4, on back of panel)</i>
640C0021G01	Display Assembly, <i>(when replacing any display other than 649C1124G01) includes:</i> Display <i>(333Q0001581)</i> Inverter <i>(333Q0001582)</i> Mounting plate <i>(640C0054H01)</i> Display Harness, for Quantum 1, 2, or 3 Sharp display <i>(640B0045H01)</i> Display Harness, for Quantum 4 <i>(649D4824H01)</i> Hardware
649C1124G01	Display Assembly, <i>(when replacing a 649C1124G01 display only) includes:</i> Display <i>(333Q0001581)</i> Mounting plate <i>(640C0054H01)</i> Hardware
	Flash Cards and Software
649A0888Gxx	Program Flash Card <i>(the xx indicates program version)</i>
649A1063G99	Quantum LX Setpoint Saver <i>(USB Drive)</i>
	Harnesses
649B0059H01	AC power supply harness
649D5581H01	DC power and communications harness
	Keypads
640D0186H01	Keypad/overlay with Frick logo <i>(Quantum™ LX)</i>
640D0060H01	Keypad/overlay with Frick logo <i>(Quantum™)</i>
649A1060G01	Keypad sticker <i>(top portion)</i> to adapt a Quantum™ keypad to Quantum™ LX keypad
649A1060G02	Keypad sticker <i>(bottom portion)</i> to adapt a Quantum™ keypad to Quantum™ LX keypad
	Panel Heater (Optional)
333Q0001179	Heater, flex, 120 VAC, 150 W
	Power Supplies
640B0060H01	DC power supply
	Quantum™ Controllers
649C1091G01	Quantum™ 4 <i>(Arcom GX1)</i>
639C0130G01	Communications Daughter board only.

QUANTUM™ LX CONDENSER/VESSEL REPLACEMENT PARTS (Page 2 of 2)

Condenser and Vessel Remote Panels

Part Number	Description
	Analog Board
640C0057G01	Analog Board #1 (<i>Replaces existing 32 channel board #1 only - no hardware</i>)
640C0057G33	Analog Board #1 (<i>Field Upgrade Kit – Includes 32 channel board #1, connectors & hardware.</i>)
	Circuit Breakers (for optional panel heater)
639A0206H03	3 Amp circuit breaker
	Connectors
649B0903H01	2-Pole connector (<i>P8 – Analog Board</i>)
333Q0001258	6-Pole connector (<i>P1 through P6 – Digital Board, P4A through P10B – Analog Board</i>)
333Q0001234	8-Pole connector (<i>P11A and P11B – Analog Board</i>)
649B0903H02	9-Pole connector (<i>P2 – Analog Board</i>)
	Digital Boards
111Q0281061	Output Module, 24-280 volt AC
333Q0000116	Input Module, 120 volt AC
333Q0001326	Fuse, 5 amp, 250 V
640C0024G41	Digital Board #1 (<i>Condenser only, replaces existing board</i>)
640C0024G42	Digital Board #2 (<i>Condenser only, replaces existing board</i>)
640C0024G51	Digital Board #1 (<i>Vessel only, replaces existing board</i>)
640C0024G52	Digital Board #2 (<i>Vessel only, replaces existing board</i>)
	Harnesses
639C0124H01	DC power
640B0059H01	AC power
649B0931H01	DC power and communications harness
640C0050H01	DC power (<i>Vessel only</i>)
649D5603H01	Wire Harness, AC Wiring (<i>Condenser only</i>)
649D5607H01	Wire Harness, AC Wiring (<i>Vessel only</i>)
649D5525H01	Harness, Digital board #2 (<i>Vessel only</i>)
649D5610H01	Harness, Digital board #2 (<i>Condenser only</i>)
640B0039H01	Shunting plug (<i>for troubleshooting only</i>)
	Panel Heater (Optional)
333Q0001179	Heater, flex, 120 VAC, 150 W
	Power Supplies
640B0060H01	DC power supply (<i>5 and 12 VDC</i>)
640B0064H01	DC power supply (<i>24 VDC - Vessel only</i>)
	HOA Modules
639C0125H01	HOA Assembly, Complete DIN Rail Mounted (<i>Condenser only</i>)
639C0126H01	HOA Assembly, Complete DIN Rail Mounted (<i>Vessel only</i>)
649B0776H01	HOA Module (<i>No labels</i>)
333Q0001738	HOA Fuse, 2 Amp

INDEX

A

About Screen.....	33
Active LED.....	11
Analog Board.....	14, 22, 23, 24, 33
Analog Board Description	22
Analog Board Settings	27
Analog Inputs	23, 24
Analog Outputs	24

B

Backlight Voltage	13
Booting	10

C

Calibration	24
Change Communications.....	16, 24
Channel	14, 15, 23, 24
Circuit Breakers.....	6, 7
Com-1.....	13
Com-2.....	13
Common.....	14, 23
Communications Board.....	13
Communications Cable	34
Communications Harness	14, 15, 23
Communications Settings	27
Communications Signals.....	14, 23
Communications Status	14
Condenser.....	2-4, 6, 8-10, 14, 21, 22, 27, 29, 30, 35-43, 54
Condenser Panel	2-4, 9, 35-43
Condor.....	8, 9, 54
Control Panel.....	10, 16, 24, 34
Control Power.....	11, 16, 24
Control Signals.....	14, 22
Control Transformer	34
Control Wiring.....	34
CPU Board	11

D

D.C. Voltage	14, 22, 23
Daisy Chain.....	14, 15, 23
DC	15
DCS.....	53
Delete Setpoints.....	32
Diagnostics.....	3, 30
Digital Board.....	4, 14-16, 21-23, 33
Digital Board Description.....	14
Digital I/O.....	10, 11, 14, 15, 16
Digital Inputs.....	15
Digital Outputs.....	15
Digital Volt Meter	8, 9, 14
Dipswitch	14, 21, 22, 27
Display.....	10, 11, 13
DVM	14, 15, 23, 34

E

EPROM	15, 23
Exit.....	32

F

Factory Setup	11
Failed Communications.....	14, 22
Faulty Sensor	24
Flash Card.....	11, 31, 32
Full System Install	31
Fuse.....	10, 15, 16
Fuse Testing.....	16
Fuses.....	6, 7

G

GND.....	24
Ground.....	10, 24, 34
Grounded.....	10, 34
Grounding Problem	24

H

HOA Modules	6, 7, 54
Hot	16

I

I/O	10, 11, 14-20, 22-24, 33, 34, 54
I/O Board	11, 14, 15, 22, 23, 33, 54
I/O Comm Failure	33
Impedance.....	24
Inductive Loads	34
Input.....	10, 14, 15, 16, 22, 23, 24, 54
Inputs Modules	15
Introduction.....	10
Isolation Transformer	34

J

Jumper.....	14, 22
Jumper Plug	15, 23
Jumper Settings	24
Jumpers.....	16, 24

K

Keyboard	4
----------------	---

L

LCD	13
LED.....	11, 14, 15, 16, 22, 23, 33
LG Phillips	13
Logic Power.....	14
Logic Voltage.....	14, 23
Loop-Back	3, 29

M

Motherboard..... 13
 Motor Control Center..... 34
 Motor CT 24
 Mouse..... 4

N

NEC..... 13
 Negative 14, 23
 Neutral..... 10, 15, 16
 Noise 34

O

Open Wire 24
 Operating System 14
 Operator Interface 4
 Opto22..... 34
 Output..... 10, 14, 15, 16, 22, 24, 54
 Output Modules 15

P

Panel Setup..... 16, 24
 PLC 34
 Power 8-11, 14-16, 22, 23, 34, 54
 Power Supply 4, 8, 9, 14, 15, 23, 54
 Power Supply Identification..... 8
 Pressure Transducers..... 23, 34

Q

Quantum™ 4..... 10, 12, 13
 Quantum™ LX 28, 31

R

Range..... 15, 23, 24, 33
 Receive (RX)..... 14, 22
 Recommended Spare Parts..... 54
 Restore Setpoints..... 32
 Return..... 14, 23
 RS-232 13, 34
 RS-422 13, 21, 34, 53

RS-485 13, 34, 53
 RX (Receive) 14, 23

S

Samsung 13
 Save Setpoints 31
 Screen 10, 11, 14, 16, 22, 24, 28, 31, 33
 Sensor 24, 33, 34
 Sensor Fault 24, 33
 Service Screen 16, 30
 Sharp 13
 Shorted Wire 24
 Shunting Plug 14, 23
 Shutdown 16, 24, 33
 Signal..... 15, 24, 34
 Software 14, 15, 22, 23, 24, 34
 Software Maintenance..... 3, 11, 31, 32
 Static..... 10, 11, 16, 24

T

Temperature Probe 34
 Temperature Transducers..... 34
 Touch-Screen..... 4
 Transducer 10, 24, 34
 Transmit (TX) 14, 22
 Troubleshooting..... 10, 11, 15, 16, 24, 34
 TX (Transmit) 14, 23
 TX/RX 11

U

Upgrading An Existing Program..... 31, 32
 USB 11, 31, 32

V

Vessel..... 2-4, 7-10, 14, 21, 22, 27, 29, 30, 44-52, 54
 Vessel Panel 2-4, 9, 44-52
 Voltage 10, 14-16, 23

W

Web Browser..... 4
 Wiring Problem..... 24





