

# RWB II

## ROTARY SCREW COMPRESSOR UNITS

ALL REFRIGERANTS

### MODELS

### 60 through 480

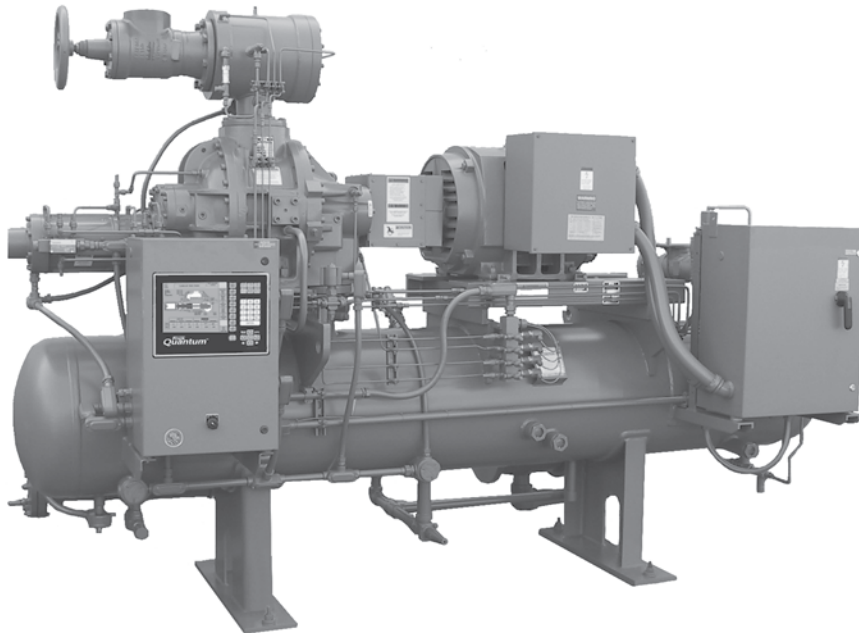

**THIS MANUAL CONTAINS RIGGING, ASSEMBLY, START-UP, AND MAINTENANCE INSTRUCTIONS. READ THOROUGHLY BEFORE BEGINNING INSTALLATION. FAILURE TO FOLLOW THESE INSTRUCTIONS COULD RESULT IN DAMAGE OR IMPROPER OPERATION OF THE UNIT.**

## Contents

PREFACE.....	3
DESIGN LIMITATIONS.....	3
JOB INSPECTION.....	3
TRANSIT DAMAGE CLAIMS.....	3
COMPRESSOR and UNIT IDENTIFICATION.....	3

### INSTALLATION

FOUNDATION.....	4
RIGGING and HANDLING.....	4
SKID REMOVAL.....	4
MOTOR MOUNTING.....	5
CHECKING MOTOR/COMPRESSOR ROTATION.....	5
COMPRESSOR/MOTOR COUPLINGS INSTALLATION.....	5
COUPLING ALIGNMENT PROCEDURE.....	7
HOT ALIGNMENT OF COMPRESSOR/MOTOR.....	9
OIL PUMP COUPLING.....	9
HOLDING CHARGE AND STORAGE.....	9
COMPRESSOR UNIT OIL.....	9
OIL CHARGE.....	9
OIL HEATER(S).....	9
OIL FILTER(S).....	10
THERMOSYPHON OIL COOLING.....	10
LIQUID INJECTION OIL COOLING (OPTIONAL).....	11
LIQUID LINE SIZES/RECEIVER VOLUME.....	12
WATER-COOLED OIL COOLING (Optional).....	12
ECONOMIZER - HIGH STAGE (OPTIONAL).....	12
ELECTRICAL.....	14
MOTOR STARTER PACKAGE.....	14
MINIMUM BURDEN RATINGS.....	15
CONTROL POWER REGULATOR.....	16

### OPERATION

OPERATION and START-UP INSTRUCTIONS.....	17
TDSH COMPRESSOR.....	17
COMPRESSOR LUBRICATION SYSTEM.....	17
NO PUMP OIL SYSTEM.....	17
COLD-START SYSTEM.....	17
DEMAND PUMP OIL SYSTEM.....	18
COMPRESSOR OIL SEPARATION SYSTEM.....	18
COMPRESSOR HYDRAULIC SYSTEM.....	19
VOLUMIZER® VOLUME RATIO CONTROL.....	19
COMPRESSOR OIL COOLING SYSTEMS.....	20
SINGLE-PORT LIQUID INJECTION.....	20
RWB II BOOSTER OR SWING DUTY APPLICATION.....	20
DUAL-PORT LIQUID INJECTION.....	20
LIQUID INJECTION ADJUSTMENT PROCEDURE.....	20
QUANTUM™ EZ-COOL™ LIQUID INJECTION ADJUSTMENT PROCEDURE.....	21
SUCTION CHECK VALVE.....	22
SUCTION CHECK VALVE BYPASS.....	23
LOW AMBIENT OPERATION.....	23
SUCTION CHECK VALVEPOWER ASSIST KIT.....	23
INITIAL START-UP.....	24
INITIAL START-UP PROCEDURE.....	24
NORMAL START-UP PROCEDURE.....	24

### MAINTENANCE

GENERAL INFORMATION.....	25
NORMAL MAINTENANCE OPERATIONS.....	25
GENERAL MAINTENANCE.....	25
COMPRESSOR SHUTDOWN and START-UP.....	25
GENERAL INSTRUCTIONS FOR REPLACING COMPRESSOR UNIT COMPONENTS.....	26
OIL FILTER (OF-1) MAIN SINGLE/DUAL.....	26
STRAINER - DEMAND OIL PUMP.....	26
STRAINER - LIQUID INJECTION.....	27
COALESCER FILTER ELEMENT(S).....	27
CHANGING OIL.....	27
DEMAND PUMP DISASSEMBLY.....	28
TROUBLESHOOTING THE DEMAND PUMP.....	30
RECOMMENDED MAINTENANCE PROGRAM.....	32
VIBRATION ANALYSIS.....	32
MOTOR BEARINGS.....	32
OIL QUALITY and ANALYSIS.....	32
OPERATING LOG.....	33
MAINTENANCE SCHEDULE.....	33
TROUBLESHOOTING GUIDE.....	34
ABNORMAL OPERATION ANALYSIS and CORRECTION.....	34
SERVICING THE COLD-START VALVE.....	34
PRESSURE TRANSDUCERS - TESTING.....	34
PRESSURE TRANSDUCERS - REPLACEMENT.....	35
SV POSITION POTENTIOMETER REPLACEMENT AND ADJUSTMENT.....	36
VOLUMIZER® POTENTIOMETER REPLACEMENT AND ADJUSTMENT.....	36
TEMPERATURE and/or PRESSURE ADJUSTMENT.....	37
OIL LEVEL TRANSMITTER REPLACEMENT.....	37
TROUBLESHOOTING RWB II COMPRESSOR.....	37
OIL SEPARATION SYSTEM.....	38
HYDRAULIC SYSTEM.....	38
LIQUID INJECTION OIL COOLING SYSTEM.....	39
DEMAND PUMP SYSTEM.....	39
THERMAL EXPANSION VALVES.....	40
JORDANTEMPERATURE REGULATOR VALVE.....	41
BARE COMPRESSOR MOUNTING.....	42
SHUTDOWN DUE TO IMPROPER OIL PRESSURE.....	42
GREASE COMPATIBILITY.....	42
NLGI Grease Compatibility Chart.....	42
<b>P &amp; I DIAGRAMS</b> .....	43
<b>PROPER INSTALLATION OF ELECTRONIC EQUIP- MENT IN AN INDUSTRIAL ENVIRONMENT</b> .....	47
<b>FORMS</b> .....	52

### SAFETY PRECAUTION DEFINITIONS



Indicates an imminently hazardous situation which, if not avoided, will result in death or serious injury.



Indicates a potentially hazardous situation or practice which, if not avoided, will result in death or serious injury.



Indicates a potentially hazardous situation or practice which, if not avoided, will result in damage to equipment and/or minor injury.

### NOTE:

Indicates an operating procedure, practice, etc., or portion thereof which is essential to highlight.

**PREFACE**

This manual has been prepared to acquaint the owner and serviceman with the INSTALLATION, OPERATION, and MAINTENANCE procedures recommended for Frick® RWB II Rotary Screw Compressor Units.

For information about the functions of the electrical control panel, communications, specifications, and wiring diagrams, see S90-010 O, M, and CS (*Quantum™* panel) or S70-200 OM (Plus panel).

It is most important that these units be properly applied to an adequately controlled refrigeration system. Your authorized Frick representative should be consulted for expert guidance in this determination.

Proper performance and continued satisfaction with these units is dependent upon:

- CORRECT INSTALLATION**
- PROPER OPERATION**
- REGULAR, SYSTEMATIC MAINTENANCE**

To ensure correct installation and application, the equipment must be properly selected and connected to a properly designed and installed system. The Engineering plans, piping layouts, etc. must be detailed in accordance with the best practices and local codes, such as those outlined in ASHRAE literature.

A refrigeration compressor is a VAPOR PUMP. To be certain that it is not being subjected to liquid refrigerant carryover it is necessary that refrigerant controls are carefully selected and in good operating condition; the piping is properly sized and traps, if necessary, are correctly arranged; the suction line has an accumulator or slugging protection; that load surges are known and provisions made for control; operating cycles and defrosting periods are reasonable; and that high side condensers are sized within system and compressor design limits.

It is recommended that the entering vapor temperature to the compressor be superheated to 10°F above the refrigerant saturation temperature. This assures that all refrigerant at the compressor suction is in the vapor state.

**DESIGN LIMITATIONS**

The compressor units are designed for operation within the pressure and temperature limits as shown in Frick Pub. E70-200 SED.

**JOB INSPECTION**

Immediately upon arrival examine all crates, boxes and exposed compressor and component surfaces for damage. Unpack all items and check against shipping lists for any possible shortage. Examine all items for damage in transit.

**TRANSIT DAMAGE CLAIMS**

All claims must be made by consignee. This is an ICC requirement. Request immediate inspection by the agent of the carrier and be sure the proper claim forms are executed.

Report damage or shortage claims immediately to Johnson Controls Inc., Frick Sales Administration Department, in Waynesboro, PA.

**COMPRESSOR and UNIT IDENTIFICATION**

Each compressor unit has 2 identification data plates. The **compressor data plate** containing compressor model and serial number is mounted on the compressor body. The **unit data plate** containing unit model, serial number and Frick sales order number is mounted on the side of the motor base.

**NOTE: When inquiring about the compressor or unit, or ordering repair parts, provide the MODEL, SERIAL, and FRICK SALES ORDER NUMBERS from these data plates.**

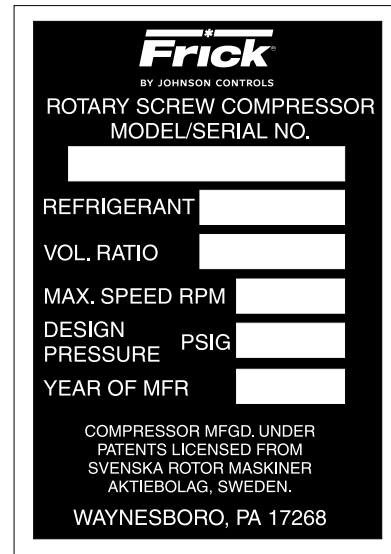

**COMPRESSOR DATA PLATE**

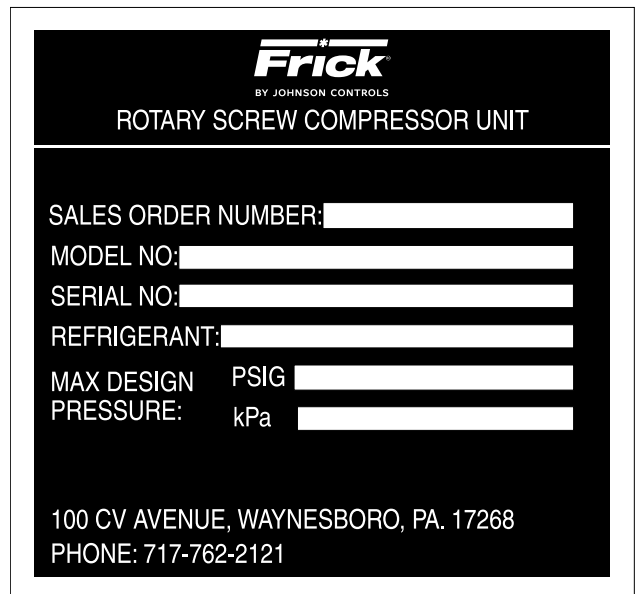

**UNIT DATA PLATE**

## Installation

### FOUNDATION

Each **RWB II** Rotary Screw Compressor Unit is shipped mounted on a wood skid which must be removed prior to unit installation.



**Allow space for servicing both ends of the unit. A minimum of 36 inches is recommended.**

The first requirement of the compressor foundation is that it must be able to support the weight of the compressor package including coolers, oil, and refrigerant charge. Screw compressors are capable of converting large quantities of shaft power into gas compression in a relatively small space and a mass is required to effectively dampen these relatively high frequency vibrations.

Firmly anchoring the compressor package to a suitable foundation by proper application of grout and elimination of piping stress imposed on the compressor is the best insurance for a trouble free installation. Use only the certified general arrangement drawings from Frick to determine the mounting foot locations and to allow for recommended clearances around the unit for ease of operation and servicing. Foundations must be in compliance with local building codes and materials should be of industrial quality.

The floor should be a minimum of 6 inches of reinforced concrete and housekeeping pads are recommended. Anchor bolts are required to firmly tie the unit to the floor. Once the unit is rigged into place (See **RIGGING** and **HANDLING**), the feet must then be shimmed in order to level the unit. The shims should be placed to position the feet roughly one inch above the housekeeping pad to allow room for grouting. An expansion-type epoxy grout must be worked under all areas of the base with no voids and be allowed to settle with a slight outward slope so oil and water can run off of the base.

When installing on a steel base, the following guidelines should be implemented to properly design the system base:

1. Use I-beams in the skid where the screw compressor will be attached to the system base. They should run parallel to the package feet and support the feet for their full length.
2. The compressor unit feet should be continuously welded to the system base at all points of contact.
3. The compressor unit should not be mounted on vibration isolators in order to hold down package vibration levels.
4. The customer's foundation for the system base should fully support the system base under all areas, but most certainly under the I-beams that support the compressor package.

When installing on the upper floors of buildings, extra precautions should be taken to prevent normal package vibration from being transferred to the building structure. It may be necessary to use rubber or spring isolators, or a combination of both, to prevent the transmission of compressor vibration directly to the structure. However, this may increase package vibration levels because the compressor is not in contact with any damping mass. The mounting and support of suction and discharge lines is also very important. Rubber or spring pipe supports may be required to avoid exciting the building structure at any pipe supports close to the compressor package. It is best to employ a vibration expert in the design of a proper mounting arrangement.

In any screw compressor installation, suction and discharge lines should be supported in pipe hangers (preferably within 2 ft of vertical pipe run) so that the lines won't move if disconnected from the compressor. See table for Allowable Flange Loads.

A licensed architect should be consulted to determine the proper foundation requirements for any large engine or turbine drive.

NOZ. SIZE NPS	ALLOWABLE FLANGE LOADS					
	MOMENTS (ft-lbf)			LOAD (lbf)		
	AXIAL	VERT.	LAT.	AXIAL	VERT.	LAT.
	M <sub>R</sub>	M <sub>C</sub>	M <sub>L</sub>	P	V <sub>C</sub>	V <sub>L</sub>
1	25	25	25	50	50	50
1.25	25	25	25	50	50	50
1.5	50	40	40	100	75	75
2	100	70	70	150	125	125
3	250	175	175	225	250	250
4	400	200	200	300	400	400
5	425	400	400	400	450	450
6	1,000	750	750	650	650	650
8	1,500	1,000	1,000	1,500	900	900
10	1,500	1,200	1,200	1,500	1,200	1,200
12	1,500	1,500	1,500	1,500	1,500	1,500
14	2,000	1,800	1,800	1,700	2,000	2,000

When applying screw compressors at high pressures, the customer must be prepared for package vibration and noise higher than the values predicted for normal refrigeration duty. Proper foundations and proper installation methods are vital; and even then, sound attenuation or noise curtains may be required to reduce noise to desired levels.

For more detailed information on Screw Compressor Foundations, please request Frick publication S70-210 IB.

### RIGGING and HANDLING



**This screw compressor package may be top-heavy. Use caution in rigging and handling.**

The unit can be moved with rigging, using a crane or forklift, by hooking into the four lifting eyes on the compressor and motor bases. If no motor is mounted, the lifting ring should be moved to the compressor side of the center of the unit because 60 percent of the weight is toward the compressor end. If a motor is mounted appropriate adjustment in the lifting point should be made to compensate for motor weight. Adjustment of the lifting point must also be made for any additions to the standard package such as an external oil cooler, etc., as the center of balance will be effected.

The unit can be moved with a forklift by forking under the skid, or it can be skidded into place with pinch bars by pushing against the skid. **NEVER MOVE THE UNIT BY PUSHING OR FORKING AGAINST THE SEPARATOR SHELL OR ITS MOUNTING SUPPORTS.**

### SKID REMOVAL

If the unit is rigged into place the skid can be removed by taking off the nuts and bolts that are fastening the unit mounting supports to the skid before lowering the unit onto the mounting surface.

If the unit is skidded into place remove the cross members from the skid and remove the nuts anchoring the unit to the skid. Using a 5 ton jack under the separator raise the unit at the compressor end until it clears the two mounting bolts. Spread the skid to clear the unit mounting support, then lower the unit to the surface. Repeat procedure on opposite end.

### MOTOR MOUNTING

The following procedure is required only when the motor is mounted at the job site.

1. Thoroughly clean the motor feet and mounting pads of grease, burrs, and other foreign matter to ensure firm seating of the motor.
2. Attach the motor to the base using the bolts and motor-raising blocks, if required. Bolt snugly through the base.
3. Weld the four kick bolts into place so that they are positioned to allow movement of the motor feet.
4. Now that the motor has been set, check to see that the shafts are properly spaced for the coupling being used. Refer to the coupling data tables for the applicable dimension (pages 5 and 6).

### CHECKING MOTOR/COMPRESSOR ROTATION



**Make sure coupling hubs are tightened to the shaft before rotating the motor to prevent them from flying off and possibly causing serious injury or death.**

**COMPRESSOR ROTATION IS CLOCKWISE WHEN FACING THE END OF THE COMPRESSOR SHAFT.** Under **NO** conditions should the motor rotation be checked with the coupling center installed as damage to the compressor may result. Bump the motor to check for correct compressor rotation. After verification, install gear or disk drive spacer, as applicable.

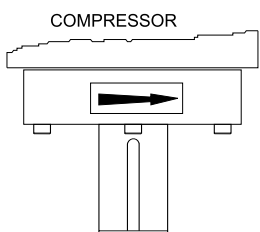

### COMPRESSOR/MOTOR COUPLINGS INSTALLATION

**RWB II** units are arranged for direct motor drive and require a flexible drive coupling to connect the compressor to the motor. Before installing, perform the following:

1. Inspect the shaft of the motor and compressor to ensure that no nicks, grease, or foreign matter is present.
2. Inspect the bores in the coupling hubs to make sure that they are free of burrs, dirt, and grit.

3. Check that the keys fit the hubs and shafts properly.

**CH COUPLING** – The T.B. Woods Elastomeric CH Coupling is used in most applications up to 600 HP. It consists of two drive hubs and a loose, gear-type Hytrel Drive Spacer. The split hub is clamped to the shaft by tightening the clamp screws. Torque is transmitted from the motor through the elastomeric gear which floats freely between the hubs. Install as follows:

1. Slide one hub onto each shaft as far as possible. It may be necessary to use a screwdriver as a wedge in the slot to open the bore before the hubs will slide on the shafts.
2. Hold the elastomeric gear between the hubs and slide both hubs onto the gear to fully engage the mating teeth. Center the gear and hub assembly so there is equal engagement on both shafts. Adjust the space between hubs as specified in the CH Coupling Data Table below.
3. Torque the clamping bolts in both hubs to the torque value given in the CH Data Table. **DO NOT USE ANY LUBRICANT ON THESE BOLTS.**
4. Proceed to Coupling Alignment.

**DBZ-B COUPLING** – The Thomas DBZ-B coupling is used on applications above 600 HP and with sleeve bearing motors that do not have axial end float constraint. The DBZ-B coupling consists of two drive hubs and a flexible metal disc drive spacer that is bolted to both hubs. A flexible steel disc pack serves as the drive element. This disc pack is bolted to the coupling hubs and prevents axial end float between the compressor and motor shafts which may occur with sleeve bearing motors. On sleeve bearing motors, the magnetic center must be determined and maintained by securing the coupling to the motor shaft with the shaft properly located.



**Injury may occur if loose clothing, etc. becomes entangled on the spinning motor shaft.**

If the motor is coupled to the compressor using a fixed-end-play coupling, such as a DBZ-B coupling, and the motor is not properly centered, additional thrust loads will be transmitted to the compressor bearings that could result in premature bearing failure. Install as follows:

1. Remove the eight locknuts and long bolts attaching the center member to the disc pack.
2. Slide the disc pack and coupling hub assemblies on their respective shafts.

**DBZ-B COUPLING DATA TABLE**

DBZ-B COUPLING SIZE	HUB FACE				MAXIMUM TOTAL		CLAMP BOLT		
	SPACING		+/-		INDICATOR READING		TORQUE (LUBE)		SIZE
	in.	mm	in.	mm	in.	mm	ft-lb	Nm	
226	3 <sup>13</sup> / <sub>16</sub>	96.8	1/64	.40	.003	.076	14	19.5	5/16 - 24 UNRF
263	4 <sup>5</sup> / <sub>16</sub>	109.5	1/32	.79	.004	.102	22	30.6	3/8 - 24 UNRF
301	4 <sup>7</sup> / <sub>8</sub>	123.8	1/32	.79	.004	.102	37	51.5	7/16 - 20 UNRF
351	5 <sup>7</sup> / <sub>8</sub>	149.2	1/32	.79	.004	.102	55	76.5	1/2 - 20 UNRF
401	6 <sup>11</sup> / <sub>16</sub>	169.9	1/32	.79	.004	.102	49	68.2	1/2 - 20 UNRF

**CH COUPLING DATA TABLE**

CH COUPLING SIZE	BETWEEN SHAFT SPACING				COUPLING HUB						MAX TOTAL INDICATOR READING		CLAMP BOLT		KEYWAY SETSCREW TORQUE		
	MIN*		MAX		SHAFT ENGAGEMENT				FACE SPACING		in.	mm	TORQUE (DRY)		SIZE	ft-lb	Nm
	in.	mm	in.	mm	in.	mm	in.	mm	in.	mm			ft-lb	Nm			
	in.	mm	in.	mm	in.	mm	in.	mm	in.	mm	in.	mm	ft-lb	Nm	ft-lb	Nm	
8	3 <sup>13</sup> / <sub>16</sub>	96.8	4	101.6	1 <sup>1</sup> / <sub>16</sub>	27.0	1 <sup>13</sup> / <sub>16</sub>	46.0	1 <sup>1</sup> / <sub>8</sub>	28.6	.004	.104	55	74.6	3/8 - 24 UNF	13	17.6
9	4 <sup>5</sup> / <sub>16</sub>	109.5	5 <sup>7</sup> / <sub>16</sub>	138.1	1 <sup>7</sup> / <sub>16</sub>	36.5	2 <sup>3</sup> / <sub>16</sub>	61.9	1 <sup>7</sup> / <sub>16</sub>	36.5	.004	.104	55	74.6	3/8 - 24 UNF	13	17.6
10	4 <sup>5</sup> / <sub>16</sub>	109.5	6 <sup>3</sup> / <sub>8</sub>	161.9	1 <sup>11</sup> / <sub>16</sub>	42.9	2 <sup>9</sup> / <sub>16</sub>	65.1	1 <sup>11</sup> / <sub>16</sub>	42.9	.004	.104	130	176.4	1/2 - 20 UNF	13	17.6
11	4 <sup>7</sup> / <sub>8</sub>	123.8	5 <sup>7</sup> / <sub>8</sub>	149.2	2	50.8	2 <sup>7</sup> / <sub>8</sub>	73.0	1 <sup>7</sup> / <sub>8</sub>	47.6	.004	.104	130	176.4	1/2 - 20 UNF	13	17.6

\* Required for shaft seal removal.

3. Adjust the distance between hub faces as specified in the DBZ-B Data Table by sliding the hubs. Key and secure hubs to the shafts by tightening setscrews.

4. Reinstall the eight previously removed bolts and locknuts. Alternately tighten each locknut as you would the lug nuts on an automobile. **NOTE: ALWAYS TURN THE NUT. NEVER TURN THE BOLT.**

5. Torque the locknuts to the value shown in the DBZ-B Data Table for the size coupling being installed.

**CAUTION** Lubricated and/or plated bolts and locknuts develop higher bolt tension with less tightening than those that are dry and not plated. Torques for lubricated and/or plated bolts and locknuts will generally fall in the lower range; while those that are dry or as received from the factory fall into the upper range. Torque readings should be observed while locknut is being turned.

6. Proceed to coupling alignment.

**SERIES 52 COUPLING** – The Thomas Series 52 coupling is also used on applications above 600 HP. It has two drive hubs, a center spool, and disc packs which are bolted between the center spool and each drive hub. A center spool and two flexible steel disc packs serve as the drive element. These three parts, situated between the motor and compressor hubs, prevent axial end float between the motor and compressor shafts. End float tends to occur with sleeve bearing motors. The magnetic center of the sleeve bearing motors must be determined and maintained by securing the coupling hub to the motor shaft with the shaft properly located.

**CAUTION** Injury may occur if loose clothing, etc. becomes entangled on the spinning motor shaft.

If the motor is coupled to the compressor using a fixed-end-play coupling such as the Series 52 coupling and the motor is not properly centered, the additional thrust loads will be transmitted to the compressor bearings. This additional thrust could result in premature bearing failure. Install as follows:

1. Before proceeding with the alignment process found on pages 7 and 8 of this manual, disassemble the Series 52 coupling **noting the arrangement of bolts, washers, and nuts as THEY MUST BE REPLACED IN THE SAME ORDER.** Mark the adjoining bolt holes of each part, the two hubs, the two disc packs, and the center spool, so they are put back together in the same position.

2. Mount the coupling hubs on their respective shafts. The hub is bored for an interference fit on the shaft. Heating of the coupling hub may be necessary for assembly. **DO NOT**

**SPOT HEAT THE HUB** as it may cause distortion. Heat in water, oil, or use a SOFT open flame and quickly position on the shaft.

3. Adjust the distance between hub faces, as specified in the Series 52 Coupling Data Table, by sliding the hubs. Key and secure the hubs to the shafts by tightening the set screws.

4. Reassemble the coupling with the disc packs and the center spool. Ensure that they are reassembled exactly as they were disassembled.

**WOODS BP SERIES COUPLING** – is also used on applications above 600 HP. It utilizes a center spool and two flexible steel disc packs as the drive element. These three parts, situated between the motor and compressor hubs, prevent axial end float between the motor and compressor shafts. End float tends to occur with sleeve bearing motors.

**CAUTION** Injury may occur if loose clothing, etc. becomes entangled on the spinning motor shaft.

If the motor is coupled to the compressor using a fixed-end-play coupling and the motor is not properly centered, the additional thrust loads will be transmitted to the compressor bearings. This additional thrust could result in premature bearing failure. Install the BP Series coupling using the following instructions:

1. Before proceeding with the alignment process in the following section, disassemble the BP Series coupling **noting the arrangement of bolts, washers, and nuts as THEY MUST BE REPLACED IN THE SAME ORDER.** Mark the adjoining bolt holes of each part, the two hubs, the two disc packs, and the center spool, so they are put back together in the same position.

2. Install the motor and compressor coupling hubs on their respective shafts with the keys. Ensure that the hubs slide, so that when the shim packs are installed, no axial stresses are transferred to the shim packs because the coupling hub is stuck.

**BP SERIES COUPLING DATA TABLE**

BP SERIES	HUB FACE *		DISC PACK		CLAMP BOLT		
	SPACING		BOLT TORQ.		TORQ. DRY		SIZE
	in.	mm	ft-lb	Nm	ft-lb	Nm	UNF
BP48	4.88	124	40	54	41	56	3/8-24
BP53	5.88	150	60	81	65	88	7/16-20
BP58	6.00	152	120	163	100	136	1/2-20
BP58	6.69	170	120	163	100	136	1/2-20
BP63	7.00	179	120	163	100	136	1/2-20

\* Max total indicator reading .003 in. or .076 mm for all sizes.

**SERIES 52 COUPLING DATA TABLE**

COUPLING SIZE	HUB FACE				MAX TOTAL INDICATOR READING				SETScrew			CLAMP BOLT TORQUE (LUBE)	
	SPACING		+/-		ANGULAR		PARALLEL		TORQUE (LUBE)		SIZE	ft-lb	Nm
	in.	mm	in.	mm	in.	mm	in.	mm	ft-lb	Nm			
225	5	127	1/32	0.914	0.004	0.102	0.004	0.102	7.5	10.5	1/4-20 UNRF	25	33.9
262	5	127	1/32	0.914	0.004	0.102	0.004	0.102	22	30.6	3/8-24 UNRF	30	40.7
312	5 1/2	139.7	3/64	1.295	0.004	0.102	0.004	0.102	37	51.5	7/16-20 UNRF	40	54.2
350	6	152.4	3/64	1.295	0.004	0.102	0.004	0.102	55	76.5	1/2-20 UNRF	95	128.8
375	7	177.8	1/16	1.574	0.004	0.102	0.004	0.102	55	76.5	1/2-20 UNRF	130	176.3
425	7	177.8	1/16	1.574	0.004	0.102	0.004	0.102	96	133.6	5/8-18 UNRF	175	237.3
450	8	203.2	1/16	1.574	0.004	0.102	0.004	0.102	96	133.6	5/8-18 UNRF	200	271.2
500	9	228.6	5/64	2.083	0.004	0.102	0.004	0.102	250	348	7/8-14 UNRF	260	352.5

**WARNING** All rotating power transmission equipment is potentially dangerous. Ensure that the couplings are properly guarded prior to turning on the power. Coupling guards are provided with the equipment and must be in place and secured properly while the equipment is in operation.

3. Reassemble the coupling with the disc packs and the center spool. Center the coupling between the shafts and ensure that the keys are fully engaged in their keyways. Ensure that they are reassembled exactly as they were disassembled. Torque disc pack hardware to specification in BP Series Coupling Data Table.

4. Key and secure the hubs to the shafts by tightening the clamping bolts. Make sure that the keyways are offset 180° to maintain balance.

5. Torque the clamping bolts of both hubs to the torque value given in the Data Table. **DO NOT USE ANY LUBRICANT ON THESE BOLTS.**

6. **IMPORTANT:** Only after the shaft clamping bolts are tightened to their final torque can the keyway setscrew be tightened! If the keyway setscrew is tightened before the shaft clamping bolts are tightened, then the hub can be cocked on the shaft.

7. Proceed to Coupling Alignment.

### COUPLING ALIGNMENT PROCEDURE

The life of the compressor shaft seal and bearings, as well as the life of the motor bearings, is dependent upon proper coupling alignment. Couplings may be aligned at the factory but realignment **MUST ALWAYS** be done on the job site after the unit is securely mounted on its foundation. Initial alignment must be made prior to start-up and rechecked after a few hours of operation. Final (HOT) field alignment can only be made when the unit is at operating temperature. After final (HOT) alignment has been made and found to be satisfactory for approximately one week, the motor may be dowelled to maintain alignment.

**NOTE: Frick recommends cold aligning the motor .005" high. This cold misalignment compensates for thermal growth when the unit is at operating temperature.**

The following procedure is applicable to both the CH and DBZ-B couplings. Dial indicators are to be used to measure the angular and parallel shaft misalignment. Coupling alignment is attained by alternately measuring angular and parallel misalignment and repositioning the motor until the misalignment is within specified tolerances.



**WARNING** ALWAYS LOCK OUT MAIN MOTOR DISCONNECT BEFORE TOUCHING MOTOR SHAFT. MISALIGNMENT MUST NOT EXCEED .004" FOR ALL CH, DBZ-B AND SERIES 52 COUPLINGS EXCEPT DBZ-B 226 WHICH SHALL NOT EXCEED .003".

### ANGULAR ALIGNMENT

1. To check angular alignment, as shown in Figure 1., attach dial indicator rigidly to the motor hub. Move indicator stem so it is in contact with the outside face of compressor hub, as shown in Figure 2.

**NOTE: When DBZ-B couplings are used on motors with sleeve bearings, it is necessary to secure the two coupling hubs with a bolt to prevent them from drifting apart when rotating.**

2. Rotate both coupling hubs several revolutions until they seek their normal axial positions.

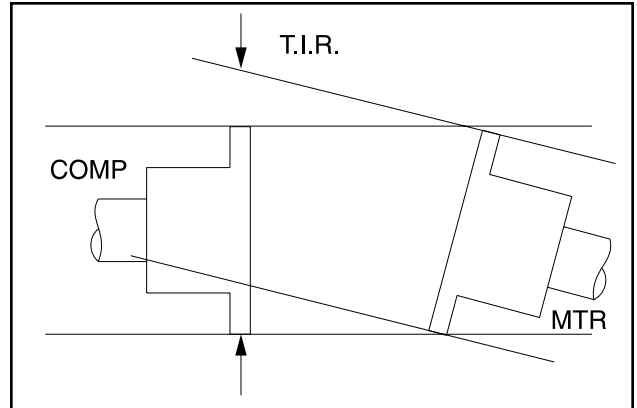

**Figure 1 - Angular Misalignment**

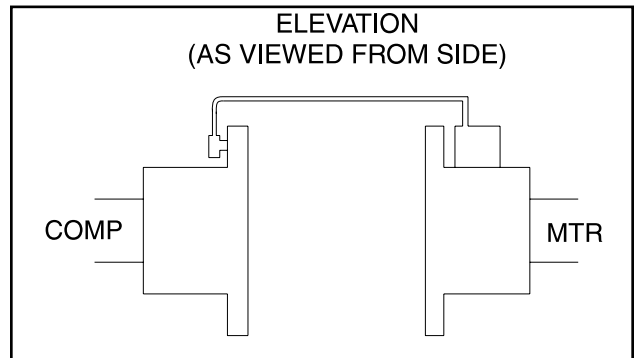

**Figure 2 - Dial Indicator Attached (at 12 o'clock)**

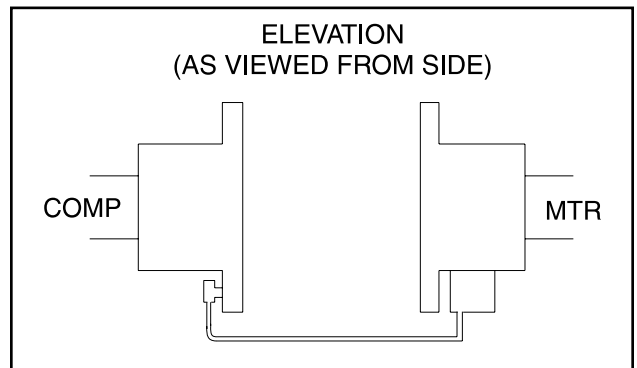

**Figure 3 - Dial Indicator at 6 o'clock**

Check the dial indicator to be sure that the indicator stem is slightly loaded so as to allow movement in both directions.

3. Set the dial indicator at zero when viewed at the 12 o'clock position, as shown in Figure 2.

4. Rotate both coupling hubs together 180° (6 o'clock position), as shown in Figure 3. At this position the dial indicator will show TOTAL angular misalignment.

**NOTE: The use of a mirror is helpful in reading the indicator dial as coupling hubs are rotated.**

5. Loosen motor anchor bolts and move or shim motor to correct the angular misalignment.

After adjustments have been made for angular misalignment retighten anchor bolts to prevent inaccurate readings. Repeat Steps 3 through 5 to check corrections. Further adjustments and checks shall be made for angular misalignment until the total indicator reading is within the specified tolerance.

## PARALLEL ALIGNMENT

6. To check parallel alignment, as shown in Figure 4, reposition dial indicator so the stem is in contact with the rim of the compressor hub, as shown in Figure 5.

Check the dial indicator to be sure that the indicator stem is slightly loaded so as to allow movement in both directions.

7. Check parallel height misalignment by setting dial indicator at zero when viewed at the 12 o'clock position. Rotate both coupling hubs together 180° (6 o'clock position). At this position the dial indicator will show TWICE the amount of parallel height misalignment.

8. Loosen motor anchor bolts and add or remove shims under the four motor feet until parallel height misalignment is within specified tolerance when anchor bolts are retightened.

**CAUTION** CARE MUST BE USED WHEN CORRECTING FOR PARALLEL MISALIGNMENT TO ENSURE THAT THE AXIAL SPACING AND ANGULAR MISALIGNMENT IS NOT SIGNIFICANTLY DISTURBED.

9. After the parallel height misalignment is within tolerance, repeat Steps 1 through 5 until angular misalignment is within specified tolerance.

10. Check parallel lateral misalignment by positioning dial indicator so the stem is in contact with the rim of the compressor hub at 3 o'clock, as shown in Figure 6.

Set indicator at zero and rotate both coupling hubs together 180° (9 o'clock position), as shown in Figure 5.

Adjust parallel lateral misalignment using the motor adjusting screws until reading is within specified tolerance.

11. Recheck angular misalignment and realign if necessary.

12. Tighten motor anchor bolts and rotate both coupling hubs together, checking the angular and parallel misalignment through the full 360° travel at 90° increments. If dial readings are in excess of specified tolerance realign as required.

13. When the coupling hubs have been aligned to within specified tolerance, a recording of the cold alignment must be made for unit records and usage during hot alignment.

**CAUTION** Install the coupling guard before operating the compressor.

**CAUTION** When installing drive spacer, make sure that hub spacing is within limits shown on the Coupling Data

Table applicable to the coupling being installed and that the clamping bolt(s) are properly torqued.

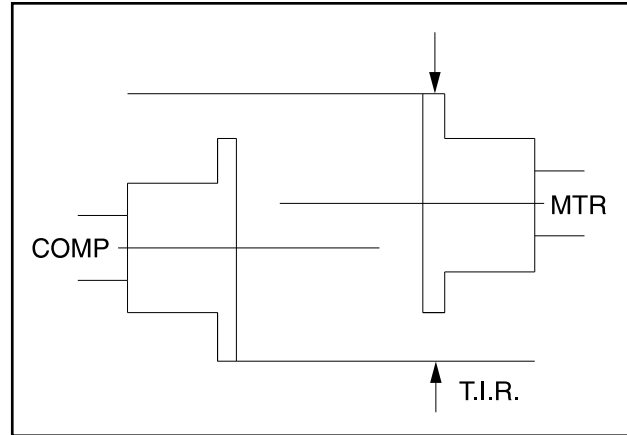

Figure 4 - Parallel Misalignment

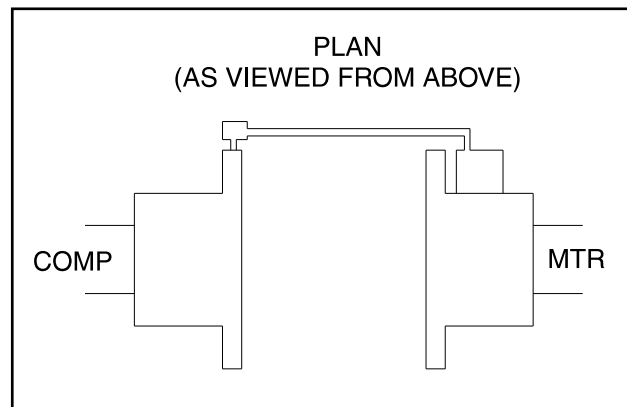

Figure 5 - Dial Indicator Attached (at 9 o'clock)

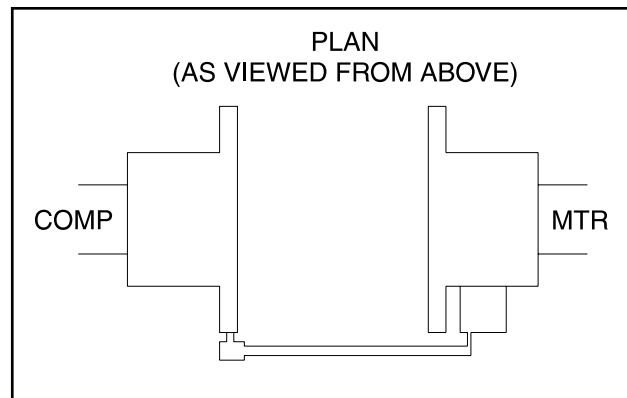

Figure 6 - Dial Indicator at 3 o'clock

## HOT ALIGNMENT OF COMPRESSOR/MOTOR

Hot alignments can only be made after the unit has operated for several hours and all components are at operating temperatures.

Shut down the unit and quickly affix dial indicator to coupling motor hub, then take readings of both the face and rim of the compressor hub. If these readings are within tolerance, record reading, attach coupling guard and restart unit. However, if the reading is not within limits, compare the hot reading with the cold alignment and adjust for this difference; i.e. if the rim at 0° and 180° readings indicates that the motor rises .005" between its hot and cold state, .005" of shims should be removed from under the motor.

After the initial hot alignment adjustment is made, restart unit and bring to operating temperature. Shut down and recheck hot alignment. Repeat procedure unit hot alignment is within specified tolerance.



**INSTALL COUPLING GUARD BEFORE OPERATING COMPRESSOR.**

## OIL PUMP COUPLING

Compressor units with direct motor/pump coupled pumps need no pump/motor coupling alignment since this is maintained by the close-coupled arrangement.

## HOLDING CHARGE AND STORAGE

Each RWB II compressor unit is pressure and leak tested at the Frick factory and then thoroughly evacuated and charged with dry nitrogen to ensure the integrity of the unit during shipping and short term storage prior to installation.

**NOTE: Care must be taken when entering the unit to ensure that the nitrogen charge is safely released.**



**Holding charge shipping gauges on separator and external oil cooler are rated for 30 PSIG and are for checking the shipping charge only. They must be removed before pressure testing the system and before charging the system with refrigerant. Failure to remove these gauges may result in catastrophic failure of the gauge and uncontrolled release of refrigerant resulting in serious injury or death.**

All units must be kept in a clean, dry location to prevent corrosion damage. Reasonable consideration must be given to proper care for the solid-state components of the microprocessor.

Unit which will be stored for more than two months must have the nitrogen charge checked periodically.

## COMPRESSOR UNIT OIL



**DO NOT MIX OILS of different brands, manufacturers, or types. Mixing of oils may cause excessive oil foaming, nuisance oil level cutouts, oil pressure loss, gas or oil leakage and catastrophic compressor failure.**

**NOTE: The oil charge shipped with the unit is the best suited lubricant for the conditions specified at the time of purchase. If there is any doubt due to the refrigerant, operating pressures, or temperatures, refer to Frick Pub. E160-802 SPC for guidance.**

## OIL CHARGE

The normal charging level is midway in the top sight glass located midway along the oil separator shell. **Normal operating level is midway between the top sight glass and bottom sight glass.** The table gives the approximate oil charge quantity.

\* Includes total in oil separator and piping. Additional oil supplied for oil cooler.

Add oil by attaching the end of a suitable-pressure-type hose to the oil charging valve, located on the top of the oil separator at the compressor end. Using a pressure-type pump and the recommended Frick oil, open the charging valve and pump oil into the separator. **NOTE: Fill slowly because oil will fill up in the separator faster than it shows in the sight glass.**

RWB II MODEL NO.	BASIC* CHARGE (gal.)
60	35
76	35
100	65
134	65
177	110
222	110
270	140
316	140
399	140
480	170

Oil distillers and similar equipment which act to trap oil must be filled prior to unit operation to normal design outlet levels. The same pump used to charge the unit may be used for filling these auxiliary oil reservoirs.

**NOTE: The sight glass located in the coalescing end of the separator near the discharge connection should remain empty.**

## OIL HEATER(S)

Standard units are equipped with two or three 500 watt oil heaters, providing sufficient heat to maintain the oil temperature for most indoor applications during shutdown cycles to permit safe start-up. Should additional heating capacity be required because of low ambient temperature, contact Frick. The heaters are energized only when the unit is not in operation.



**DO NOT ENERGIZE THE HEATERS when there is no oil in the unit, the heaters will burn out. The oil heaters will be energized whenever 120 volt control power is applied to the unit and the compressor is not running, unless the 16 amp circuit breaker in the micro enclosure is turned off.**

## OIL FILTER(S)



**Use of filter elements other than Frick may cause warranty claim may to be denied.**

The oil filter(s) and coalescer filter element(s) shipped with the unit are best suited to ensure proper filtration and operation of the system.

## THERMOSYPHON OIL COOLING

Thermosyphon oil cooling is an economical, effective method for cooling oil on screw compressor units. Thermosyphon cooling utilizes liquid refrigerant at condenser pressure and temperature that is partially vaporized at the condenser temperature in a plate and shell vessel, cooling the oil to within 15°F of that temperature. The vapor, at condensing pressure, is vented to the condenser inlet and reliquified. This method is the most cost effective of all currently applied cooling systems since no compressor capacity is lost or compressor power penalties incurred. The vapor from the cooler need only be condensed, not compressed. Refrigerant flow to the cooler is automatic, driven by the thermosyphon principle and cooling flow increases as the oil inlet temperature rises.

**EQUIPMENT** - The basic equipment required for a thermosyphon system consists of:

1. A source of liquid refrigerant at condensing pressure and temperature, located in close proximity to the unit to minimize piping pressure drop. The liquid level in the refrigerant source must be 6 to 8 feet minimum above the center of the oil cooler.
2. A plate and shell oil cooler with:  
Plate Side: Oil 400 psi design  
Shell Side: Refrigerant 400 psi design

Due to the many variations in refrigeration system design and physical layout, several systems for assuring the above criteria are possible.

**SYSTEM OPERATION** - Liquid refrigerant fills the cooler shell side up to the Thermosyphon receiver liquid level. See Figure 7.

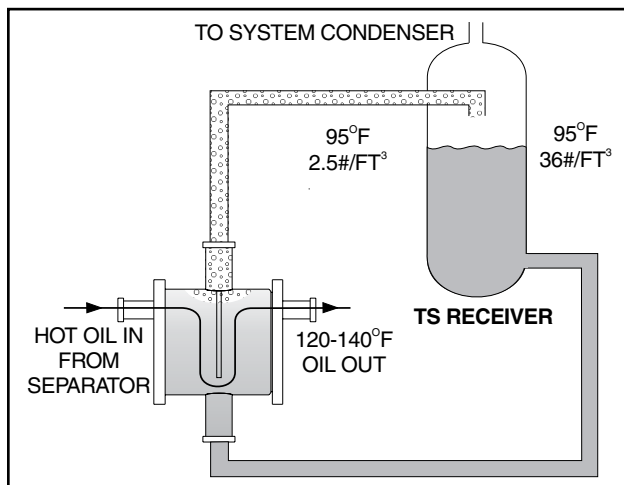

Figure 7

Hot oil (above the liquid temperature) flowing through the cooler will cause some of the refrigerant to boil and vaporize. The vapor rises in the return line. The density of the refrigerant liquid/vapor mixture in the return line is considerably less than the density of the liquid in the supply line. This imbalance provides a differential pressure that sustains a flow condition to the oil cooler. This relationship involves:

1. Liquid height above the cooler.
2. Oil heat of rejection.
3. Cooler size and piping pressure drops.

Current thermosyphon systems are using two-pass oil coolers and flow rates based on 3:1 overfeed.

The liquid/vapor returned from the cooler is separated in the receiver. The vapor is vented to the condenser inlet and need only be reliquified since it is still at condenser pressure.

**OIL TEMPERATURE CONTROL** - Oil temperature will generally run about 15 - 35°F above condensing temperature. In many cases, an oil temperature control is not required if condensing temperature is above 65°F as oil temperature can be allowed to float with condenser temperature.

Condensing Temperature: 65°F - 105°F  
Oil Temperature: 80°F - 140°F

**INSTALLATION** - The plate and shell type thermosyphon oil cooler with oil-side piping and a thermostatically controlled mixing valve (if ordered) are factory mounted and piped. The customer must supply and install all piping and equipment located outside of the shaded area on the piping diagram with consideration given to the following:

1. The refrigerant source, thermosyphon or system receiver, should be in close proximity to the unit to minimize piping pressure drop.
2. The liquid level in the refrigerant source must be **6 to 8 feet minimum** above the center of the oil cooler.
3. A safety valve should be installed if refrigerant isolation valves are used for the oil cooler.

The component and piping arrangement shown in Figure 8, is intended only to illustrate the operating principles of thermosyphon oil cooling. Other component layouts may be better suited to a specific installation. Refer to publication E70-900E for additional information on Thermosyphon Oil Cooling.

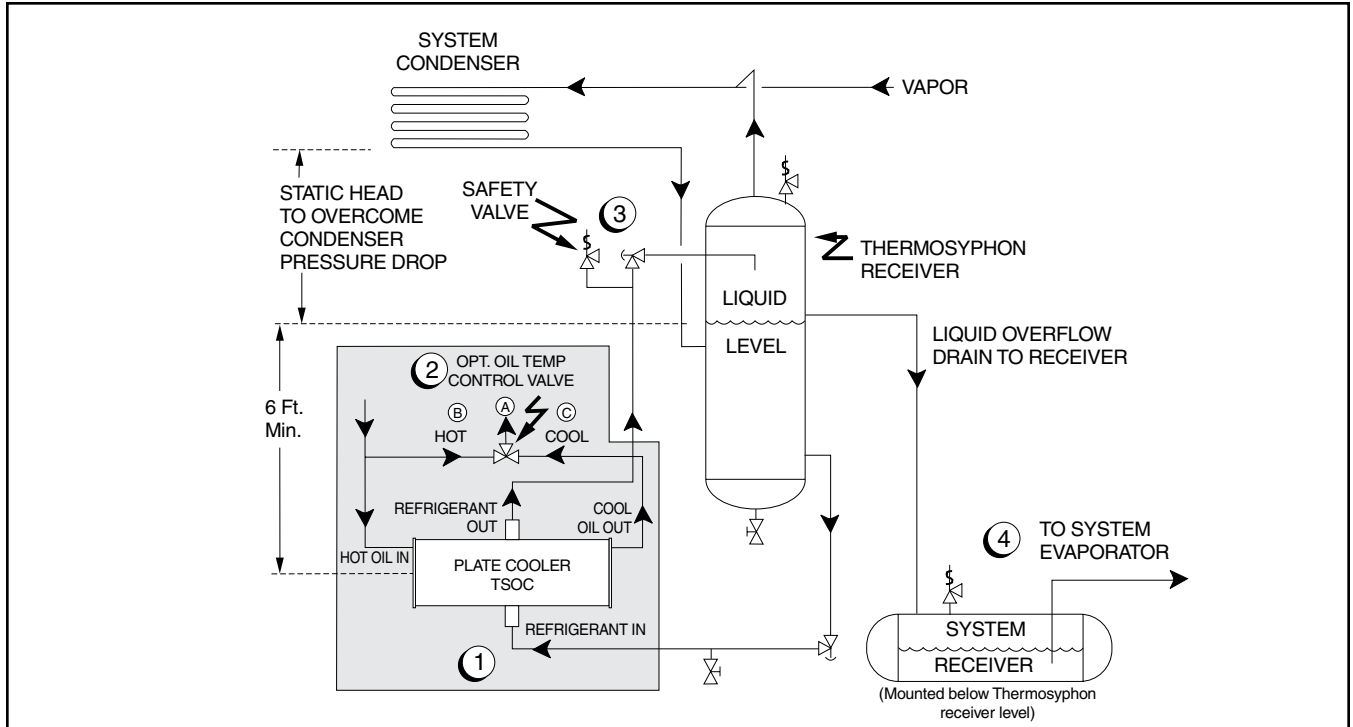

**Figure 8**

1. The thermosyphon oil cooler is supplied with the oil side piped to the compressor unit and stub ends supplied on the refrigerant side.
2. A three-way oil temperature control valve is required where condensing temperature is expected to go below 65°F.
3. A refrigerant-side safety valve is required in this location only when refrigerant isolation valves are installed between the cooler and thermosyphon receiver. If no valves are used between the cooler and TSOC receiver, the safety valve on the TSOC receiver must be sized to handle the volume of both vessels. Then, the safety valve on the cooler vent (liquid refrigerant side) can be eliminated.
4. The system receiver must be below the thermosyphon receiver in this arrangement.

### LIQUID INJECTION OIL COOLING (OPTIONAL)

The liquid injection system provided on the unit is self-contained but requires the connection of the liquid line sized as shown in the table and careful insertion of the expansion valve bulb into the thermowell provided in the separator. High pressure gas is connected through the regulator to the external port on the liquid injection valve to control oil temperature.

**NOTE: For booster applications the high pressure gas connection must be taken from a high side source (high stage compressor discharge). This should be a 3/8" line connected into the solenoid valve provided. This gas is required by the expansion valve external port to control oil temperature.**

It is **IMPERATIVE** that an uninterrupted supply of high pressure liquid refrigerant be provided to the injection system at all times. Two items of **EXTREME IMPORTANCE** are the design of the receiver/liquid injection supply and the size of the liquid line.

It is recommended that the receiver be oversized sufficiently to retain a 5-minute supply of refrigerant for oil cooling. The evaporator supply must be secondary to this consideration. Two methods of accomplishing this are shown.

The dual dip tube method uses two dip tubes in the receiver. The liquid injection tube is below the evaporator tube to ensure continued oil cooling when the receiver level is low. See Figure 9.

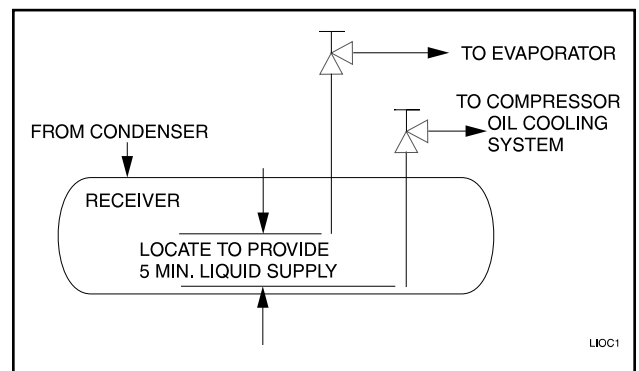

**Figure 9**

The level-control method utilizes a float level control on the receiver to close a solenoid valve feeding the evaporator when the liquid falls below that amount necessary for 5 minutes of liquid injection oil cooling. See Figure 10.

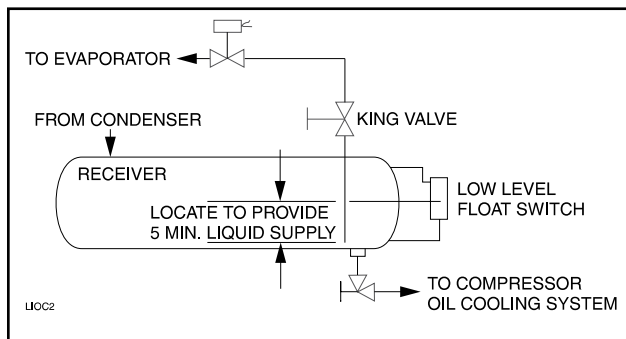

Figure 10

### LIQUID LINE SIZES/RECEIVER VOLUME

Liquid line sizes and the additional receiver volume (quantity of refrigerant required for 5 minutes of liquid injection oil cooling) are given in the following table:

#### LIQUID LINE SIZE and RECEIVER VOLUME

RWB II MODEL **	LINE SIZE*		POUND PER 5 MIN.	LIQUID VOLUME CU FT
	SCH 80 PIPE	OD TUBING		
<b>R-717 HIGH STAGE*</b>				
100-134	3/4	—	80	2.0
177-270	1	—	140	4.0
316-480	1-1/4	—	250	7.0
<b>R-717 BOOSTER*</b>				
100-134	1/2	—	20	0.5
177-270	3/4	—	30	1.0
316-480	1	—	40	1.5

\* Based on 100 foot liquid line. For longer runs, increase line size accordingly.

\*\* For models 60 and 76, contact Frick engineering.

### WATER-COOLED OIL COOLING (Optional)

The plate and shell type water-cooled oil cooler is mounted on the unit complete with all oil piping. The customer must supply adequate water connections and install the two-way water regulating valve if ordered in lieu of a three-way oil temperature valve. It is recommended (local codes permitting) that the water regulator be installed on the water outlet connection. Insert the water regulator valve bulb and well in the chamber provided on the oil outlet connection. Determine the size of the water-cooled oil cooler supplied with the unit, then refer to table for the water connection size. **The water supply must be sufficient to meet the required flow.**

Frick recommends a closed-loop system for the waterside of the oil cooler. Careful attention to water treatment is essential to ensure adequate life of the cooler if cooling tower water is used. **It is imperative that the condition of cooling water and closed-loop fluids be analyzed regularly and as necessary and maintained at a pH of 7.4, but not less than 6.0 for proper heat exchanger life.** After initial start-up of the compressor package, the strainer at the inlet of the oil cooler should be cleaned several times in the first 24 hours of operation.

In some applications, the plate and shell oil cooler may be subjected to severe water conditions, including high temperature and/or hard water conditions. This causes accelerated scaling rates which will penalize the performance of the heat exchanger. A chemical cleaning process will extend the life of the Plate and Shell heat exchanger. It is important to establish regular cleaning schedules.

**Cleaning:** A 3% solution of Phosphoric or Oxalic Acid is recommended. Other cleaning solutions can be obtained from your local distributor, but they must be suitable for stainless steel. The oil cooler may be cleaned in place by back flushing with recommended solution for approximately 30 minutes. After back flushing, rinse the heat exchanger with fresh water to remove any remaining cleaning solution.

**NOTE:** The water-regulating valve shipped with the unit will be sized to the specific flow for the unit.

### OIL COOLER DATA TABLE

RWB II MODEL	TYPICAL COOLER	CONNECTION	
		INLET	OUTLET
60 - 134 High Stage	116 Plates	3"	3"
100 - 270 Booster	66 Plates	2"	2"
177/222 High Stage	190 Plates	3"	3"
270 High Stage	288 Plates	3"	4"
316/399 Booster	56 Plates	3"	3"
316/399 High Stage	136 Plates	4"	5"
480 Booster	72 Plates	3"	3"
480 High Stage	188 Plates	4"	5"

### ECONOMIZER - HIGH STAGE (OPTIONAL)

The economizer option provides an increase in system capacity and efficiency by subcooling liquid from the condenser through a heat exchanger or flash tank before it goes to the evaporator. The subcooling is provided by flashing liquid in the economizer cooler to an intermediate pressure level. The intermediate pressure is provided by a port located part way down the compression process on the screw compressor.

As the screw compressor unloads, the economizer port will drop in pressure level, eventually being fully open to suction. Because of this, an output from the microprocessor is generally used to turn off the supply of flashing liquid on a shell and coil or DX economizer when the capacity falls below approximately 45%-60% capacity (85%-90% slide valve position). This is done because the compressor will be more efficient operating at a higher slide valve position with the economizer turned off, than it will at a low slide valve position with the economizer turned on. Please note however that shell and coil and DX economizers can be used at low compressor capacities in cases where efficiency is not as important as assuring that the liquid supply is subcooled. In such cases, the economizer liquid solenoid can be left open whenever the compressor is running.

Due to the tendency of the port pressure to fall with decreasing compressor capacity, a back-pressure regulator valve (BPR) is generally required on a flash economizer system (Figure 13) in order to maintain some preset pressure difference between the subcooled liquid in the flash vessel and the evaporators. If the back-pressure regulator valve is not used on a flash economizer, it is possible that no pressure difference will exist to drive liquid from the flash vessel to the evaporators, since the flash vessel pressure will approach suction pressure at a decreased slide valve position. In cases where wide swings in pressure are anticipated in the flash economizer vessel, it may be necessary to add an outlet pressure regulator to the flash vessel outlet to avoid overpressurizing the economizer port, which could result in motor overload. Example: A system feeding liquid to the flash vessel in batches.

The recommended economizer systems are shown below. Notice that in all systems there should be a strainer (STR) and a check valve (VCK) between the economizer vessel and the economizer port on the compressor. The strainer prevents dirt from passing into the compressor and the check valve prevents oil from flowing from the compressor unit to the economizer vessel during shutdown.

**CAUTION** Other than the isolation valve needed for strainer cleaning, it is essential that the strainer be the last device in the economizer line before the compressor. Also, piston-type check valves are recommended for installation in the economizer line, as opposed to disc-type check valves. The latter are more prone to gas-pulsation-induced failure. The isolation and check valves and strainer should be located as closely as possible to the compressor, preferably within a few feet.

For refrigeration plants employing multiple compressors on a common economizing vessel, regardless of economizer type, each compressor must have a back-pressure regulating valve in order to balance the economizer load, or gas flow, between compressors. The problem of balancing load becomes most important when one or more compressors run at partial load, exposing the economizer port to suction pressure. In the case of a flash vessel, there is no need for the redundancy of a back-pressure regulating valve on the vessel and each of the multiple compressors. Omit the BPR valve on the flash economizer vessel and use one on each compressor, as shown in Figure 14. It is also recommended that the back-pressure regulating valves, used on economizer lines, should be specified with electric shutoff option. The electric shutoff feature is necessary to prevent flow from the common economizer vessel to the suction side of a stopped compressor, through the suction check valve bypass line, if the other compressors and the common economizer vessel are still operating and the HV2 valve on the suction bypass is open.

For refrigeration plants using a Packaged Refrigerant Recirculation (PRR) unit and a direct expansion (DX) economizer system it is necessary to operate the liquid feed solenoid on the PRR unit and the liquid feed solenoid on the DX vessel off of a common signal to avoid liquid overfeed on the DX economizer system.

If multiple compressors are operated with a common economizer vessel, it is necessary to install a back-pressure regulator valve with an electric shutoff option in the vapor line piped to the compressor's economizer port. If an electric shut-off is not installed in the economizer vapor line, valve HV-2 must remain closed to avoid a gas bypass from the economizer line through the suction check valve bypass, back to the suction line on a compressor that is shut down.

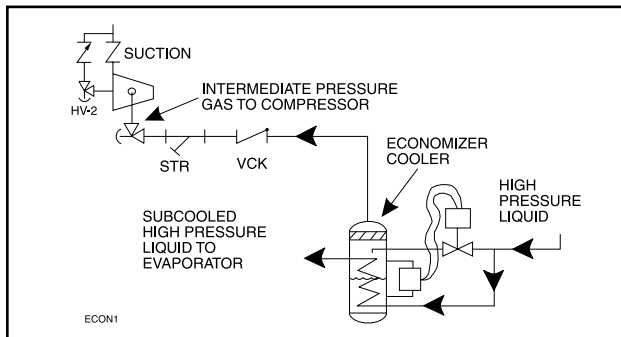

**Figure 11 - Shell and Coil Economizer System**

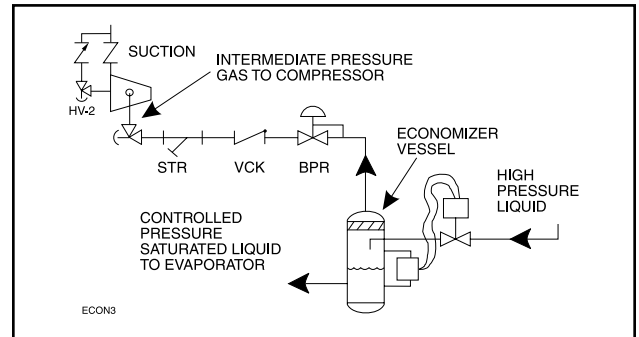

**Figure 13 - Flash Economizer System**

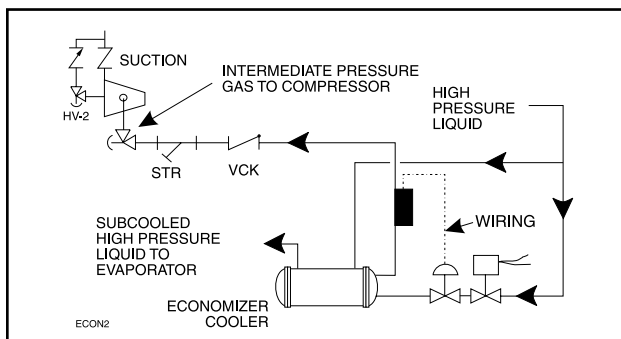

**Figure 12 - Direct Expansion Economizer System**

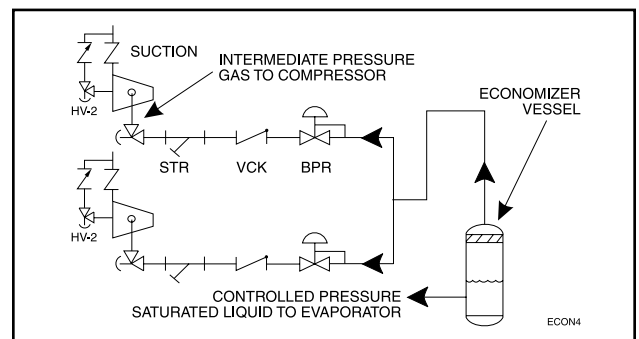

**Figure 14 - Multiple Compressor Economizer System**

## ECONOMIZER LOAD BALANCING

The most energy efficient manner to operate an economizer system, when using multiple compressors on a common economizer vessel, is to take as much of the flash gas as possible to the compressors that are fully loaded. This can be done in at least two ways.

1. Use the economizer output from the microprocessor to turn off a solenoid, or to actuate the electric shutoff option on a back-pressure regulator, based on percent of slide valve travel. This will direct all the flash vapor to the other loaded compressors.

2. A dual-setpoint back-pressure regulator valve can be used in each of the individual economizer vapor lines. When a compressor is running near full load, the BPR valve will operate on the desired setpoint, or basically wide open, to minimize pressure drop in the line. When one compressor unloads below the slide valve position where the economizer output on the microprocessor turns on, the dual-setpoint feature of the regulator can be actuated by this output to control the pressure, on the vessel side of the regulator, to be a few psi higher. Consequently, the flash gas will be sent to the loaded compressors first, until they can't handle all the vapor and the pressure in the vessel starts to rise. Then, some of the vapor will go to the unloaded compressor to help maintain the vessel at the desired pressure. An example of a back-pressure regulator with electric shutoff and the dual-setpoint feature is an R/S A4ADS.

## ELECTRICAL

**NOTE:** Before proceeding with electrical installation, read the instructions in the section "Proper Installation of Electronic Equipment in an Industrial Environment".

RWB II units are supplied with a **QUANTUM** control system. Care must be taken that the controls are not exposed to physical damage during handling, storage, and installation. The single-box control door must be kept tightly closed to prevent moisture and foreign matter from entry.

**NOTE:** All customer connections are made in the single-box control mounted on the oil separator. This is the **ONLY** electrical enclosure and it should be kept tightly closed whenever work is not being done in it.

### VOLTAGE PROTECTION

Frick® does not advise nor support the use of UPS power systems in front of the Quantum™ panel. With a UPS power system providing shutdown protection for the Quantum™, the panel may not see the loss of the 3-phase voltage on the motor because the UPS could prevent the motor starter contactor from dropping out. With the starter contactor still energized, the compressor auxiliary will continue to feed an "Okay" signal to the panel. This will allow the motor to be subjected to a fault condition on the 3-phase bus. Some fault scenarios are:

1. The 3-phase bus has power "on" and "off" in a continuous cyclic manner which may cause the motor to overheat due to repeated excessive in-rush currents.
2. Motor cycling may damage the coupling or cause other mechanical damage due to the repeated high torque motor "bumps".
3. Prolonged low voltage may cause the motor to stall and overheat before the motor contactor is manually turned off.

Under normal conditions, the loss of 3-phase power will shut the Quantum™ panel down, and it will restart upon power return. If the panel was in:

- **Auto** – Compressor motor will return to running as programmed.
- **Remote** – The external controller would reinitialize the panel and proceed to run as required.
- **Manual** – The compressor will have to be restarted manually after the 3-phase bus fault has been cleared.

If the local power distribution system is unstable or prone to problems, there are other recommendations to satisfy these problems. If power spikes or low or high line voltages are the problem, then Frick® recommends the use of a Sola® constant voltage (CV) transformer with a line suppression feature. If a phase loss occurs, then you will typically get a high motor amp shutdown. If problems continue to exist, then an examination of the plant's power factor may be in order.

Unless careful design failure analysis is considered in the implementation of power systems, the alternative solutions provide a safer and less expensive implementation. In either case, only one Sola® may be used per compressor. Each compressor needs to be individually isolated from each other through a dedicated control transformer. Sharing a common control power source is an invitation for ground loops and the subsequent unexplainable problems.

## MOTOR STARTER PACKAGE



**SBC Board damage may occur without timer relay installed in control panel as shown in Starter Wiring Diagram, Figure 15. All Frick motor starter packages have the timer relay as standard.**

**Wiring Diagram, Figure 15. All Frick motor starter packages have the timer relay as standard.**

### STARTER WIRING DIAGRAM

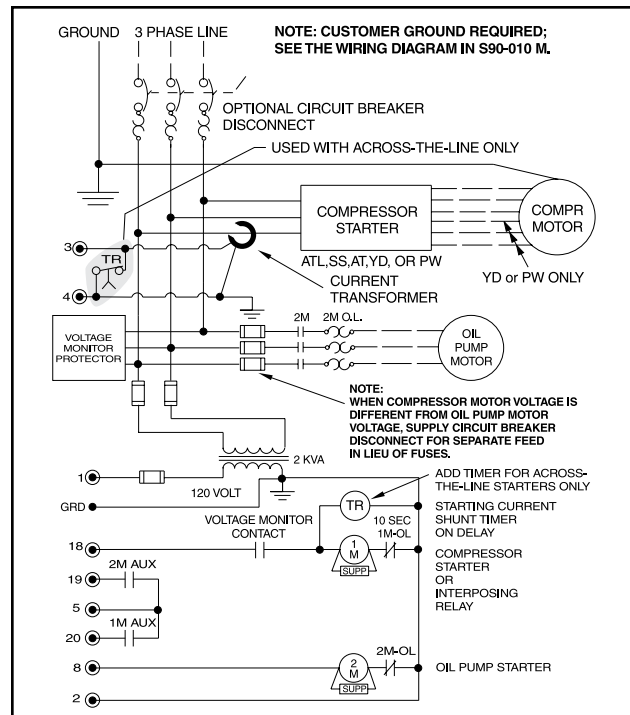

Figure 15

Motor starter and interlock wiring requirements are shown in the **Starter Wiring Diagram**. All of the equipment shown is supplied by the installer unless a starter package is purchased separately from Frick. Starter packages should consist of:

1. The compressor motor starter of the specified HP and voltage for the starting method specified (across-the-line, autotransformer, wye-delta, or solid-state).

**NOTE: If starting methods other than across-the-line are desired, a motor/compressor torque analysis must be done to ensure that sufficient starting torque is available, particularly in booster applications. Contact FRICK if assistance is required.**

2. If specified, the starter package can be supplied as a combination starter with circuit breaker disconnect. However, the motor overcurrent protection/disconnection device can be applied by others, usually as a part of an electrical power distribution board.

3. The oil pump starter with fuses, or in the case where the compressor motor is a different voltage from the oil pump motor, with a circuit breaker disconnect suitable for separate power feed.

4. A 2.0 KVA control power transformer (CPT) to supply 120 volt control power to the microprocessor control system and separator oil heaters is included. If environmental conditions require more than the usual two 500 watt oil heaters, an appropriately oversized control transformer will be required. If frequent power fluctuations are anticipated or extremely noisy power lines are encountered, a regulating control transformer should be considered. Contact FRICK for assistance.

5. For customer-supplied across-the-line starters, a shunting device must be installed across the Current Transformer (terminals 3 & 4).



**If the shunting device is not installed, the Analog I/O board on the Quantum panel may be severely**

**damaged at start-up (see Starter Wiring Diagram, Figure 15).**

6. One each normally open compressor motor and oil pump motor starter auxiliary contact should be supplied. In addition to the compressor and oil pump motor starter coils, the CT and CPT secondaries should be wired as shown on the starter package wiring diagram. The load on the control panel for the compressor motor starter coil should not exceed a Nema size 3 starter. For larger starters, an interposing relay must be used to switch the compressor motor starter coil(s).

**NOTE: Do not install a compressor HAND/OFF/AUTO switch in the starter package as this would bypass the compressor safety devices.**

7. The compressor motor Current Transformer (CT) is installed on any one phase of the compressor leads.

**NOTE: The CT must see all the current of any one phase, therefore in wye-delta applications BOTH leads of any one phase must pass through the CT.**

**CURRENT TRANSFORMER (CT) RATIOS**

The CT ratio for various motor sizes (with a 5 amp secondary) is given in the following table:

HP	VOLTAGE						
	200	230	380	460	575	2300	4160
20	100:5	100:5	50:5	50:5	50:5	-	-
25	100:5	100:5	50:5	50:5	50:5	-	-
30	200:5	100:5	100:5	50:5	50:5	-	-
40	200:5	200:5	100:5	100:5	50:5	-	-
50	200:5	200:5	100:5	100:5	100:5	-	-
60	300:5	200:5	200:5	100:5	100:5	-	-
75	300:5	300:5	200:5	200:5	100:5	-	-
100	400:5	300:5	200:5	200:5	200:5	-	-
125	500:5	400:5	300:5	200:5	200:5	-	-
150	600:5	500:5	300:5	300:5	200:5	-	-
200	800:5	600:5	400:5	300:5	300:5	100:5	50:5
250	800:5	800:5	500:5	400:5	300:5	100:5	50:5
300	1000:5	1000:5	600:5	500:5	400:5	100:5	50:5
350	-	1000:5	800:5	500:5	500:5	100:5	100:5
400	-	-	800:5	600:5	500:5	200:5	100:5
450	-	-	1000:5	800:5	600:5	200:5	100:5
500	-	-	1000:5	800:5	600:5	200:5	100:5
600	-	-	1200:5	1000:5	800:5	200:5	100:5
700	-	-	-	1200:5	1000:5	200:5	200:5
800	-	-	-	-	1000:5	300:5	200:5
900	-	-	-	-	1200:5	300:5	200:5
1000	-	-	-	-	-	300:5	200:5
1250	-	-	-	-	-	400:5	200:5
1500	-	-	-	-	-	500:5	300:5

**MINIMUM BURDEN RATINGS**

The following table gives the minimum CT burden ratings. This is a function of the distance between the motor starting package and the compressor unit.

BURDEN RATING		MAXIMUM DISTANCE FROM FRICK PANEL		
ANSI	VA	USING # 14 AWG	USING # 12 AWG	USING # 10 AWG
B-0.1	2.5	15 ft	25 ft	40 ft
B-0.2	5	35 ft	55 ft	88 ft
B-0.5	12.5	93 ft	148 ft	236 ft

## CONTROL POWER REGULATOR

Compressor units that will be used in areas that suffer brown-outs and other significant power fluctuations can be supplied with a control power regulator. See the following illustration, Recommended Regulator Installation.

### RECOMMENDED REGULATOR INSTALLATION

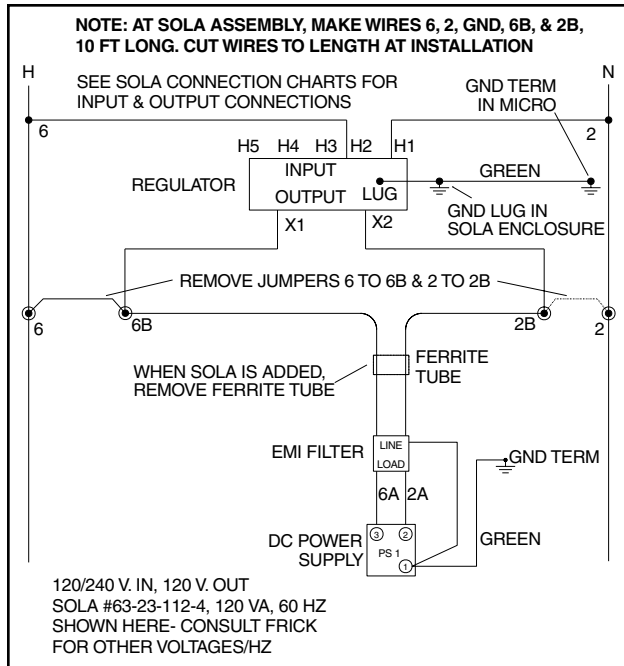

Figure 16

## BATTERY BACKUP

The battery backup is used only for date and time retention during power interruption. All setpoints and other critical information are saved to onboard flash memory.

**NOTE: It is not necessary to disconnect the battery backup during extended downtime.**

## Operation

### OPERATION and START-UP INSTRUCTIONS

The Frick RWB II Rotary Screw Compressor Unit is an integrated system consisting of six major subsystems:

1. Control Panel (See publication S90-010 O, M, & CS for Quantum Panel and S70-200 OM for the Plus panel).
2. Compressor
3. Compressor Lubrication System
4. Compressor Oil Separation System
5. Compressor Hydraulic System
6. Compressor Oil Cooling System
7. Compressor Easy-Start System

The information in this section of the manual provides the logical step-by-step instructions to properly start up and operate the RWB II Rotary Screw Compressor Unit.

**The following subsections must be read and understood before attempting to start or operate the unit.**

### TDSH COMPRESSOR

The Frick RWB II rotary screw compressor utilizes mating asymmetrical profile helical rotors to provide a continuous flow of refrigerant vapor and is designed for both high pressure and low pressure applications. The compressor incorporates the following features:

1. High capacity roller bearings to carry radial loads at both the inlet and outlet ends of the compressor.
2. Heavy-duty, four-point angular contact ball bearings to carry axial loads are mounted at the discharge end of compressor.
3. Balance pistons located in the inlet end of the compressor to reduce axial loads on the axial load bearings and increase bearing life.
4. Moveable slide valve to provide infinite step capacity control from 100 to 10%.
5. VOLUMIZER® volume ratio control to allow infinitely variable volume ratio from 2.2 to 5.0 during compressor operation for all models except 480 which is 2.2 to 4.2.
6. A hydraulic unloader cylinder to operate the slide stop and slide valve.
7. Bearing and casing design for 350 PSI discharge pressure. **This PSI rating applies only to the compressor and does not reflect the design pressure of the various system components.**
8. All bearing and control oil vented to closed thread in the compressor instead of suction port to avoid performance penalties from superheating suction gas.
9. Shaft seal design to maintain operating pressure on seal well below discharge pressure, for increased seal life.
10. Oil injected into the rotors to maintain good volumetric and adiabatic efficiency even at very high compression ratios.
11. Shaft rotation clockwise facing compressor, suitable for all types of drives. **SEE CAUTION.**
12. Dual compressor casing design for very low airborne noise transmission.



**CAUTION** COMPRESSOR ROTATION IS CLOCKWISE WHEN FACING THE COMPRESSOR DRIVE SHAFT. THE COMPRESSOR SHOULD NEVER BE OPERATED IN REVERSE ROTATION AS BEARING DAMAGE WILL RESULT.

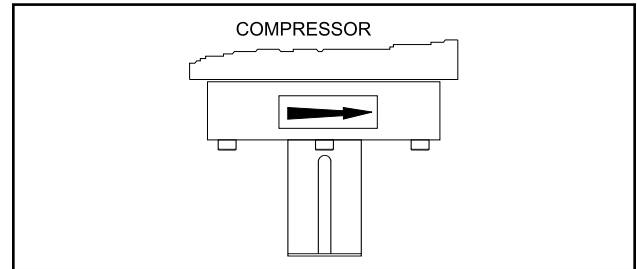

Figure 17

### COMPRESSOR LUBRICATION SYSTEM

The lubrication system on an RWB II screw compressor unit performs several functions:

1. Provides lubrication to bearings and seal.
2. Provides a cushion between the rotors to minimize noise and vibrations.
3. Helps keep the compressor cool and prevents overheating.
4. Provides an oil supply to hydraulically actuate the slide valve and slide stop.
5. Provides oil pressure to the balance pistons to help increase bearing life.
6. Provides an oil seal between the rotors to prevent rotor contact or gas bypassing.

The compressor unit may be equipped with either a no pump or a demand pump lubrication system. Additionally, either system may contain dual oil filters and liquid injection, water-cooled, or thermosyphon oil cooler for compressor oil cooling.

### NO PUMP OIL SYSTEM

The RWB II screw compressor unit is designed to be self-lubricating. Oil being supplied to the compressor from the oil separator is at system head pressure. Within the compressor, oil porting to all parts of the compressor is vented back to a point in the compressor's body that is at a pressure lower than compressor discharge pressure. The compressor's normal operation makes the compressor unit operate essentially as its own oil pump. All oil entering the compressor is moved by the compressor rotors out the compressor outlet and back to the oil separator.

For normal high-stage operation an oil pump is not required.

### COLD-START SYSTEM

The RWB II package is equipped with a special "cold start" discharge check valve on the gas outlet connection of the oil separator (see Figure 18). This valve causes the oil separator to develop oil pressure rapidly on initial start in order to lubricate the compressor without requiring an oil pump, even in cold ambient temperatures with all pressures equalized.

For high-stage packages, the cold-start valve is equipped with a large spring that creates 30 psi of pressure in the oil separator (above suction pressure), for lubrication of the compressor.

**DO NOT ATTEMPT TO SERVICE THE COLD START VALVE. PLEASE CONTACT THE FRICK SERVICE DEPARTMENT.**

Once the compressor is running it will begin to force gas to the condenser at connection P2. As the condenser heats up it will begin to rise in pressure as the compressor suction pulls down in pressure. As soon as differential pressure is developed between the condenser and suction, these pressures act across a piston inside the cold-start valve to partially overcome the spring force. When the differential pressure reaches and exceeds 30 psi, the piston fully overcomes the spring force and powers the valve fully open for very low operating pressure drop.

For booster applications, the valve is equipped with a lighter spring which produces 15 psi oil pressure above suction pressure before it fully powers open.

The RWB II package is also equipped with a suction check valve bypass. The oil separator will slowly bleed down to system suction pressure when the unit is stopped. This allows the compressor drive motor to have an easier start, and the discharge check valve will seat more tightly. See the "SUCTION CHECK VALVE BYPASS" section for operation.

**NOTE: For alarm descriptions and shutdown or cutout parameters, see publication S90-010 O.**

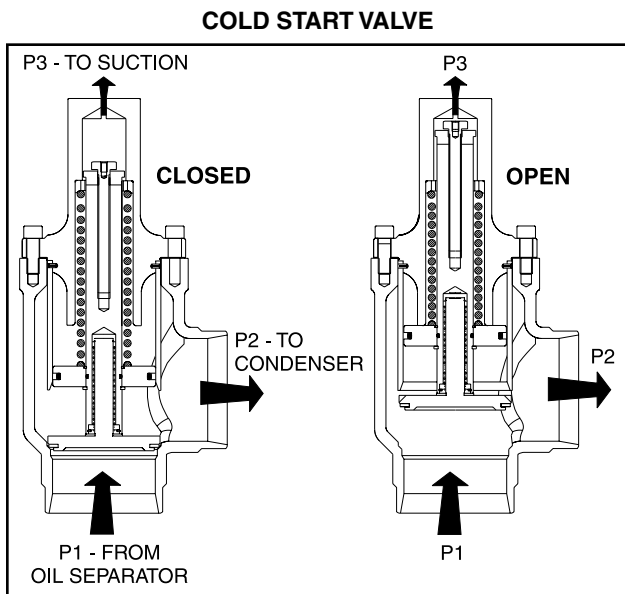

Figure 18

### DEMAND PUMP OIL SYSTEM

This system is designed to provide adequate compressor lubrication for some high stage applications that operate with low differential pressure across the compressor suction and discharge and all booster applications.

During the period from start-up to normal operation the oil pressure alarm and oil pressure cutout setpoints will vary according to formulas built into the microprocessor control program.

**NOTE: For alarm descriptions and shutdown or cutout parameters, see publication S90-010 O.**

### COMPRESSOR OIL SEPARATION SYSTEM

The RWB II is an oil flooded screw compressor. Most of the oil discharged by the compressor separates from the gas flow in the oil charge reservoir. Some oil, however, is discharged as a mist which does not separate readily from the gas flow and is carried past the oil charge reservoir. One or more coalescer filter elements then COALESCE the oil mist into droplets which fall to the bottom of the coalescer section of the oil separator. The return of this oil to the compressor is controlled by a throttling valve on both high stage and booster applications (see Figure 19).

**NOTE: Open throttling valve only enough to keep coalescer end of separator free of oil.**

The sight glass located near the bottom of the coalescer section of the oil separator should remain empty during normal operation. If an oil level develops and remains in the sight glass, a problem in the oil return separation system or compressor operation has developed. Refer to MAINTENANCE for information on how to correct the problem.

**NOTE: Normal operating level is midway between the top sight glass and bottom sight glass.**

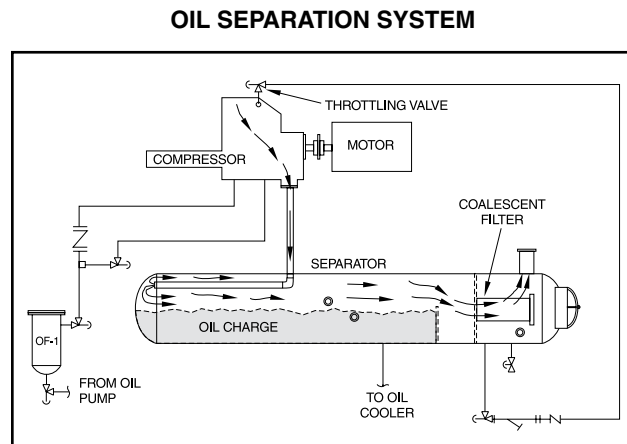

Figure 19

**COMPRESSOR HYDRAULIC SYSTEM**

The compressor hydraulic system moves the movable slide valve (MSV) to load and unload the compressor. It also moves the movable slide stop (MSS) to increase or decrease the compressor's volume ratio ( $V_i$ ).

The hydraulic cylinder located at the inlet end of the TDS compressor serves a dual purpose. It is separated by a fixed bulkhead into two sections. The movable slide valve (MSV) section is to the left of the bulkhead and the movable slide stop (MSS) to the right. Both sections are considered double acting hydraulic cylinders as oil pressure moves the pistons in either direction.

Both sections are controlled by double-acting, four-way solenoid valves which are actuated when a signal from the appropriate microprocessor output energizes the solenoid valve.

**Compressor Loading:** The compressor loads when MSV solenoid YY2 is energized and oil flows from the oil manifold through valve ports P and B to cylinder port SC-2 and enters the load side of the cylinder. Simultaneously, oil contained in the unload side of the cylinder flows out cylinder port SC-1 through valve ports A and T to compressor closed thread port.

**Compressor Unloading:** The compressor unloads when MSV solenoid YY1 is energized and oil flows from the oil manifold through valve ports P and A to cylinder port SC-1 and enters the unload side of the cylinder. Simultaneously, oil contained in the load side of the cylinder flows out compressor port SC-2 through valve ports B and T to compressor closed thread port.

**NOTE: High Stage Operation: An alternative piping arrangement has been provided to increase slide valve response time during high stage operation.**

Higher operating pressures will slow the compressor unloading response time. Unloading response time can be increased by closing valve 1 (oil manifold pressure) and opening valve 2 to compressor suction pressure. See Figure 20. **NEVER OPEN VALVE 1 AND VALVE 2 AT THE SAME TIME DURING COMPRESSOR OPERATION.**

**VOLUMIZER® VOLUME RATIO CONTROL**

**$V_i$  Increase**

The volume ratio  $V_i$  is increased when MSS solenoid YY3 is energized and oil flows from the oil manifold through valve ports P and A to cylinder port SC-3 and enters the increase side of the cylinder. Simultaneously, oil contained in the decrease side of the cylinder flows out cylinder port SC-4 through valve ports B and T to compressor closed thread port.

**$V_i$  Decrease**

The volume ratio  $V_i$  is decreased when MSS solenoid YY4 is energized and oil flows from the oil manifold through valve ports P and B to cylinder port SC-4 and enters the decrease side of the cylinder. Simultaneously, oil contained in the increase side of the cylinder flows out cylinder port SC-3 through valve ports A and T to compressor closed thread port.

**MSV and MSS HYDRAULIC CYLINDER and SOLENOID VALVES**

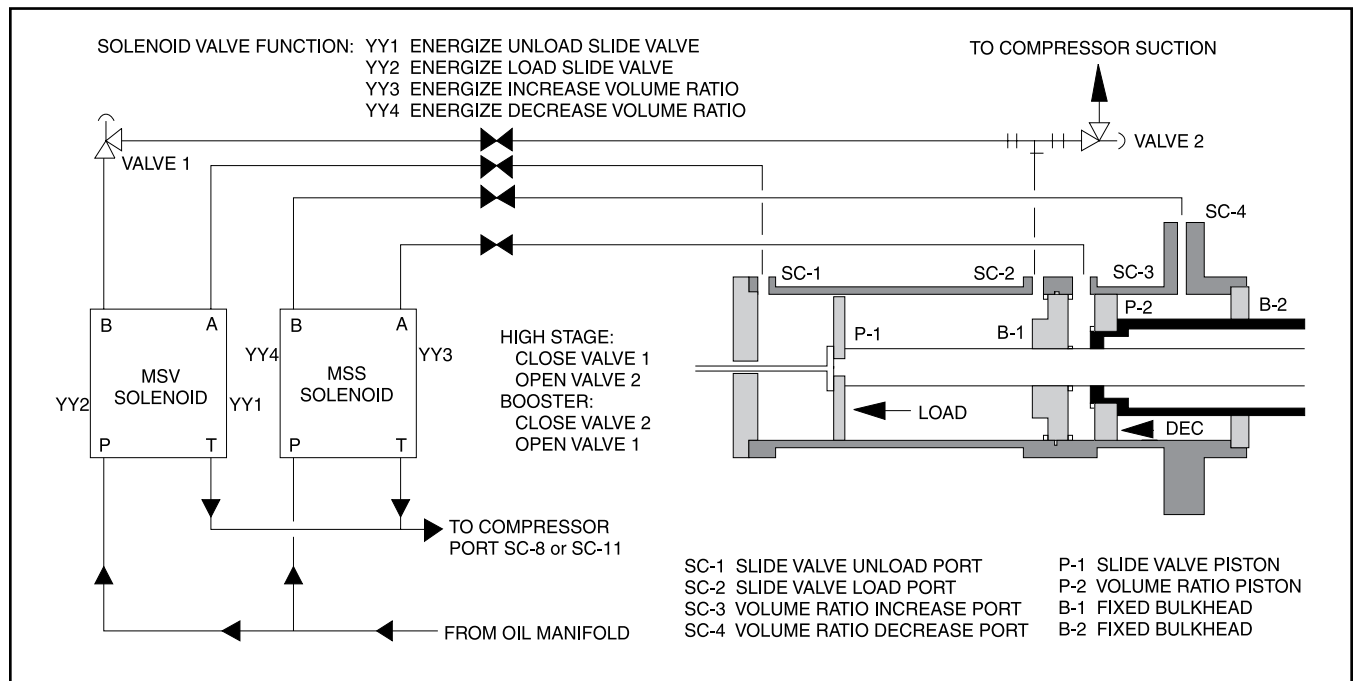

**Figure 20**

## COMPRESSOR OIL COOLING SYSTEMS

The RWB II unit can be equipped with one of several systems for controlling the compressor oil temperature. They are single or dual-port liquid injection, or thermosyphon and water-cooled oil coolers. Each system is automatically controlled, independent of compressor loading or unloading.

Oil cooling systems should maintain oil temperature within the following ranges for R-717 and R-22:

Liquid Injection Oil Cooling	External* Oil Cooling
130 - 170°F	120 - 160°F

\* Thermosyphon oil cooling (TSOC) or Water-cooled oil cooling (WCOC).

## SINGLE-PORT LIQUID INJECTION

The single-port liquid injection system is designed to permit liquid refrigerant injection into one port on the compressor at any given moment and operates as outlined.

Solenoid valve SV5 is energized by the microprocessor when the temperature sensor, installed in the oil manifold, exceeds the LICO set point. High pressure liquid refrigerant is then supplied to the temperature control valve (TCV). The temperature control valve is equalized to a constant back pressure by the differential pressure control valve (PDCV). The differential pressure control valve uses discharge gas to maintain downstream pressure. The gas downstream of the differential pressure control valve is bled off to the compressor suction to ensure steady and constant operation of the valve.

## RWB II BOOSTER OR SWING DUTY APPLICATION

Discharge gas from the high stage compressor is required to assist the differential pressure control valve (PDCV) in providing the temperature control valve (TCV) with a constant back pressure.

A solenoid valve SV6 is installed before the differential pressure control valve (PDCV) to prevent migration of high pressure gas during shutdown. A Frick-installed timer limits the high pressure gas to only thirty seconds duration, since intermediate gas pressure and spring tension are sufficient to maintain closure on unit shutdown. A metering valve is also provided for use as a service valve and to allow discharge gas flow regulation to prevent excessive force and resulting closure "hammering".

A field-installed 1/4 inch OD tubing connection is required between the high stage compressor discharge piping line (or receiver) and the check valve.

## DUAL-PORT LIQUID INJECTION

The dual-port liquid injection system is designed to obtain the most efficient compressor performance at high and low compression ratios by permitting injection of liquid refrigerant into one of two ports optimally located on the compressor. This minimizes the performance penalty incurred with liquid injection oil cooling.

The dual-port system contains all the components of the single-port system with the addition of a double acting solenoid valve SV7 and operates as outlined.

Solenoid valve SV5 is energized by the microprocessor when the temperature sensor, installed in the oil manifold, exceeds the LICO set point. Liquid refrigerant is then passed through the temperature control valve (TCV) to the double-acting solenoid valve SV7. Depending on the compressor's operating volume ratio (Vi), the microprocessor will select the flow of the liquid refrigerant to either compressor port SL-1 or SL-2, whichever is more efficient.

When the compressor operates BELOW 3.5 Vi, compressor port SL-1 supplies the liquid cooling. When the (Vi) rises ABOVE 3.5 Vi, port SL-2 supplies the liquid cooling.

The temperature control valve is equalized to a constant back pressure by the differential pressure control valve (PDCV).

Both the differential pressure control valve (PDCV) and the double-acting solenoid valve SV7 use discharge gas to maintain downstream pressure. The gas downstream of both valves is bled off to the compressor suction to ensure steady and constant operation of the valves.

## LIQUID INJECTION ADJUSTMENT PROCEDURE

Adjustments must be made to ensure the oil is at the proper temperature. When the adjustments have been made correctly, the oil temperature, the discharge temperature and the temperature of the oil in the separator should all be approximately the same. (Refer to P&I Diagram)

Carefully insert The bulb from the thermal expansion valve (TXV) into the well in the discharge pipe between the compressor and the oil separator. Then open the valve to the oil separator high pressure connection.

Next, open the refrigerant supply valve, remove the cap on the pressure regulating valve (PCV), and close the adjusting valve.

### For low temperature oil – 125° to 135°F

After the unit has been started, wait for the oil temperature to reach 122°F. This is the preprogrammed temperature to open the liquid feed solenoid in the liquid injection supply line.

Open the adjusting valve only until the needle on the gauge begins to move a very small amount.

Next, adjust the pressure regulating valve to approximately 80 psig by turning the adjustment ring inside the top of the valve with a 5/16" Allen wrench. Turn the wrench clockwise to raise the oil temperature, and counterclockwise to lower the oil temperature.

After the adjustment s been, made wait until the oil and discharge temperatures have had a chance to stabilize before readjusting. The end result should be between 135° and 140°F.

### For high temperature oil – 160° to 170°F

After the unit has been started, wait for the oil temperature to reach 122°F. This is the preprogrammed temperature to open the liquid feed solenoid in the liquid injection supply line.

Open the adjusting valve only until the needle on the gauge begins to move a very small amount.

Next, adjust the pressure regulating valve to approximately 30 psig by turning the adjustment ring inside the top of the valve with a 5/16" Allen wrench. Turn the wrench clockwise to raise the oil temperature, and counter-clockwise to lower the oil temperature. After the adjustment has been made wait until the oil and discharge temperatures have had a chance to stabilize before readjusting. The end result should be between 160° and 170°F.

**Liquid Injection Oil Cooling - Ammonia**

To tell if the unit you are starting has a low or high temperature liquid injection valve, look at the power head of the Thermal Expansion Valve.

If the unit is using Ammonia as a refrigerant and is for low temperature the Sporlan number on the power head should be Y764 or Y830. Set the oil temperature for 135°F.

If the unit is using Ammonia as a refrigerant and is for high temperature the Sporlan number on the power head should be Y1199 or Y1201. Set the oil temperature for 160°F.

**Liquid Injection Oil Cooling - Halocarbon**

To tell if the unit you are starting has a low or high temperature liquid injection valve, look at the power head of the Thermal Expansion Valve.

If the unit is using Halocarbon as a refrigerant and is for low temperature, the Sporlan number on the power head should be L3. Set the oil temperature for 135°F.

If the unit is using Halocarbon as a refrigerant and is for high temperature, the Sporlan number on the power head should be Y1200 or Y1202. Set the oil temperature for 160°F.

When the unit has high temperature liquid injection oil cooling, set the oil temperature alarm for 170°F.

Set the oil temperature cutout for 180°F.

When the unit has low temperature liquid injection oil cooling, set the oil temperature alarm and cutout at the default values set in the microprocessor.

**QUANTUM™ EZ-COOL™ LIQUID INJECTION ADJUSTMENT PROCEDURE**

Use the following steps in setting up the EZ-Cool™ LIOC using the Quantum™ Panel PID loop from analog output channel one and the HMMR motorized valve.

- Ensure that the HMMR valve is wired to the Quantum™ control panel per drawing 649B0898.
- Set the High Oil Temperature alarm and shutdown setpoints to 170°F and 180°F for all refrigerants.
- Once this is done press **[Menu]** > **[Calibration]** > **[OK]** > **[More]** > **[Analog Out Calibration]**.

- Press **[Calibration Setpoints]** and enter a **[2]** for Input Channel to Output for analog output 1 > **[Enter]** > **[OK]**. The screen should appear as shown in Figure 21.
- Press **[Analog 1 Setpoints Calibration]** to calibrate the 4-20mA output range.
- Press **[Menu]** > **[Control Setup]** > **[More]** > **[PID Setup]**, you should see the screen in Figure 22.
- Press **[PID Setup]** for Output Channel 1 PID.

Analog Output Setup				Thu 7 Mar 2002 23:16:43
	Input Channel to Output	Input	Output	Calibration Setpoints
Analog Output 1	2	196.4 F	58.8 %	Analog 1 Setpoints Calibration
Analog Output 2	1	196.4 F	58.8 %	Analog 2 Setpoints Calibration
Analog Output 3	14	13.6 %	13.6 %	Analog 3 Out Calibration
Analog Output 5	21	72.9 PSIG	17.5 %	Analog 5 Out Calibration
Analog Output 6	21	72.9 PSIG	17.5 %	Analog 6 Out Calibration

**Figure 21**

Refer to the screen in Figure 23 for the following steps:

- Press **[Change Setpoints]**
- Set the following setpoints as a starting point. Adjustment to the **Proportional Gain** may be necessary. The use of values in the integral and derivative gains should not be necessary.

SETPOINT: 150°F for all refrigerants  
 Dead Band: 2.0°F  
 Integral Gain: 0.00  
 High Limit: 100%  
 Off Value: 0%  
 Proportional Gain: 25.00  
 Derivative Gain: 0.00  
 Low Limit: 0%

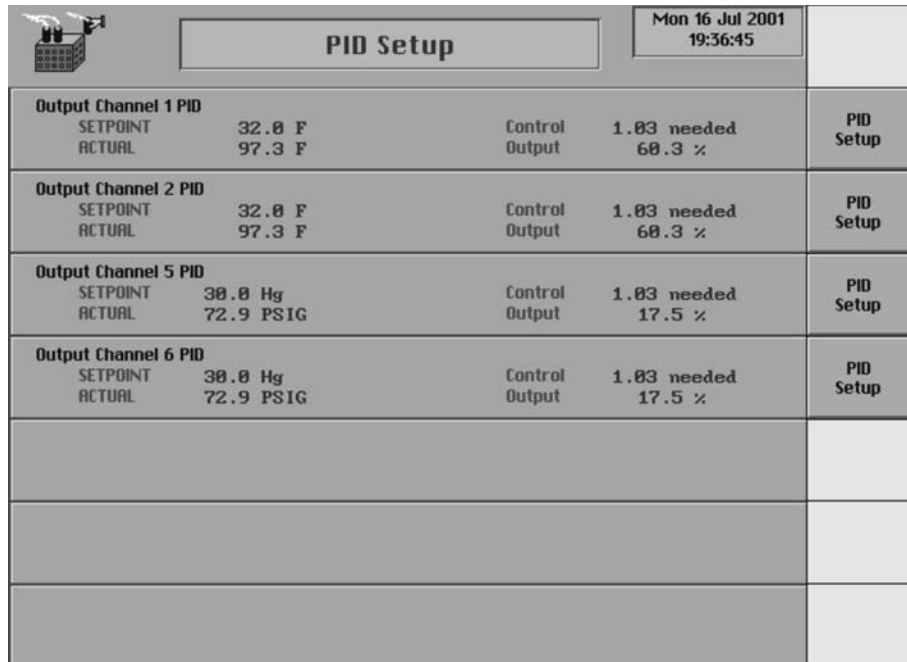

PID Setup				Mon 16 Jul 2001 19:36:45
<b>Output Channel 1 PID</b>	SETPOINT	32.0 F	Control	1.03 needed
	ACTUAL	97.3 F	Output	60.3 %
<b>Output Channel 2 PID</b>	SETPOINT	32.0 F	Control	1.03 needed
	ACTUAL	97.3 F	Output	60.3 %
<b>Output Channel 5 PID</b>	SETPOINT	30.0 Hg	Control	1.03 needed
	ACTUAL	72.9 PSIG	Output	17.5 %
<b>Output Channel 6 PID</b>	SETPOINT	30.0 Hg	Control	1.03 needed
	ACTUAL	72.9 PSIG	Output	17.5 %

Figure 22

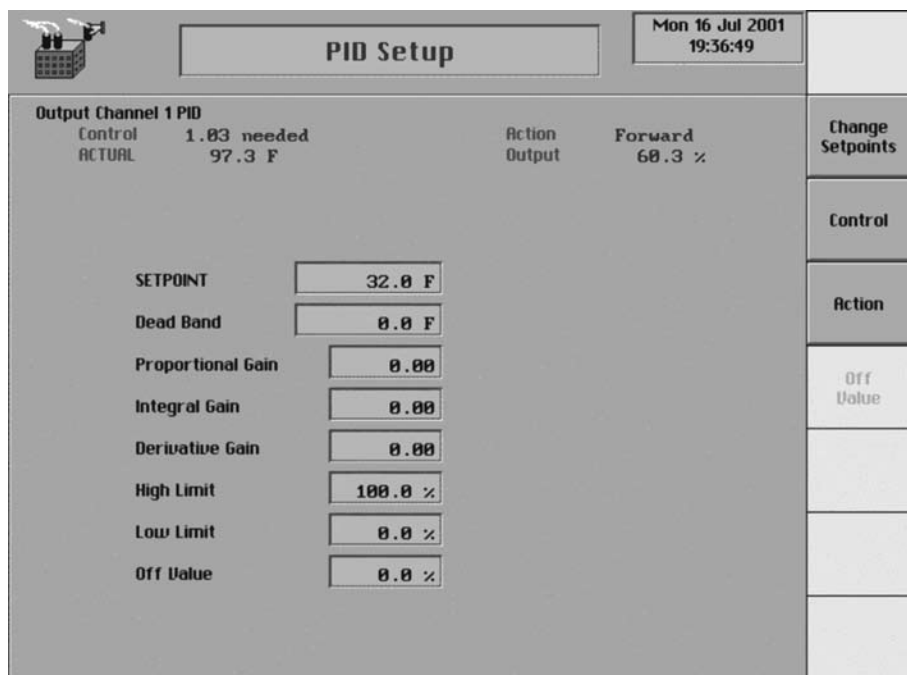

PID Setup				Mon 16 Jul 2001 19:36:49
<b>Output Channel 1 PID</b>	Control	1.03 needed	Action	Forward
	ACTUAL	97.3 F	Output	60.3 %
SETPOINT	<input type="text" value="32.0 F"/>			Change Setpoints
Dead Band	<input type="text" value="0.0 F"/>			Control
Proportional Gain	<input type="text" value="0.00"/>			Action
Integral Gain	<input type="text" value="0.00"/>			Off Value
Derivative Gain	<input type="text" value="0.00"/>			
High Limit	<input type="text" value="100.0 %"/>			
Low Limit	<input type="text" value="0.0 %"/>			
Off Value	<input type="text" value="0.0 %"/>			

Figure 23

Use the [Control], [Action] and [Off Value] keys to set the following:

- Set the **Control** for: **When Running**
- Set the **Action** for: **Forward**
- Set the **Off Value** for: **0%**
- The **ACTUAL** value should be reading the current discharge temperature.
- The **Output** should be reading 0% with the machine off line.
- Regarding the adjustment of the **Proportional Gain** setpoint, the goal is to increase or decrease the **Proportional Gain** setpoint, until the discharge temperature holds within or close to the **Dead Band** with minimal fluctuation of the output signal.

### SUCTION CHECK VALVE

Low temperature booster compressor operations require a more positive suction check valve closure. This is accomplished by allowing the high stage discharge pressure gas to assist the spring tension and intermediate pressure closing force.

Frick provides a power assist kit consisting of a mounted and wired solenoid valve and timer on all RWB II booster compressors. High stage compressors are supplied with a power assist kit when the design suction temperature is less than or equal to 0°F. The wiring diagram in S90-010 M (Quantum) or S70-200 OM (Plus) shows the wiring included when required. Introduction of high discharge pressure gas is made to the check valve. A timer limits the high pressure gas to only thirty seconds duration since intermediate gas

pressure and spring tension are sufficient to maintain closure on unit shutdown. A metering valve is also provided for use as a service valve and to allow discharge gas flow regulation to prevent excessive force and resulting closure “hammering”.

### SUCTION CHECK VALVE BYPASS

During normal operation, valve HV1 is closed. This is a pump-out connection to allow refrigerant removal to the system suction prior to evacuation for servicing. Valve HV-2 must be open in most systems at all times. It should normally be cracked open to allow the oil separator to slowly bleed down to system suction pressure when the unit is stopped (having this valve cracked open allows the compressor drive motor to have an easier start, and the discharge check valve will seat more tightly). If the drive coupling backspins, start closing the valve until the backspin stops. If the separator oil level foams excessively on shutdown, HV-2 should be closed slightly. If the separator takes more than 20 – 30 minutes to equalize to suction pressure after shutdown, HV-2 can be opened slightly. See Figure 24.

**NOTE: HV-2 should be closed on systems with suction pressures below atmospheric pressure, to avoid the possibility of air leakage into the system during shutdown. However, on high-stage or booster systems with check valve, HV-2 can remain open.**

HV-2 also should be closed on systems that utilize autcycle to restart the compressor, based on increase in system suction pressure during shutdown, if slowly bleeding the oil separator gas to suction will raise the suction pressure enough to cause short cycling of the compressor.

Also it is important to close HV-2, if the oil pump is to be run for long periods of time with the compressor stopped, to avoid oil being pumped up the suction line.

If multiple compressors are operated with a common economizer vessel, it is necessary to install a back-pressure regulator valve with an electric shut-off option in the vapor line piped to the compressor's economizer port. If an electric shut-off is not installed in the economizer vapor line, valve HV-2 must remain closed to avoid a gas bypass from the economizer line through the suction check valve bypass, back to the suction line on a compressor that is shut down.

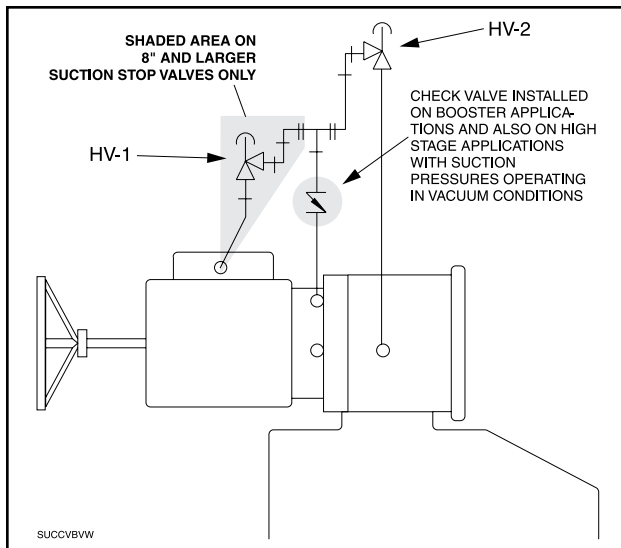

**Figure 24**

### LOW AMBIENT OPERATION

It is recommended that oil separators be insulated as a minimum requirement to preserve the heat generated by the oil heaters. It is important that the coalescer end of the separator be insulated to prevent refrigerant condensation.

On systems located outdoors or in unheated buildings where the ambient temperature could drop below +40°F, insulating and/or heat tracing of the compressor lube oil systems is highly recommended.

When low ambient temperatures (below +20°F) are a possibility, it is recommended that lube oil lines, oil filters, oil pumps and oil coolers be heat traced and insulated.

Freeze-up protection must also be provided for all water-cooled equipment

### SUCTION CHECK VALVE POWER ASSIST KIT

Low temperature booster compressor operations require a more positive suction check valve closure. This is accomplished by allowing the high pressure discharge gas to assist the spring tension and intermediate pressure closing force. The power assist kit (Figure 25) is factory installed with the discharge gas pressure being supplied from a connection on the dry end of the oil separator. It may be necessary to provide high pressure gas from a high stage compressor discharge for booster applications in which the operating pressure differential on the booster compressor is insufficient to close the suction check valve.

Frick provides a power assist kit consisting of a mounted and wired solenoid valve and timer on all RDB booster compressors. Introduction of high discharge pressure gas is made to the check valve. A timer limits the high pressure gas to only thirty seconds duration since intermediate gas pressure and spring tension are sufficient to maintain closure on unit shutdown. A metering valve is also provided for use as a service valve and to allow discharge gas flow regulation to prevent excessive force and resulting closure “hammering”.

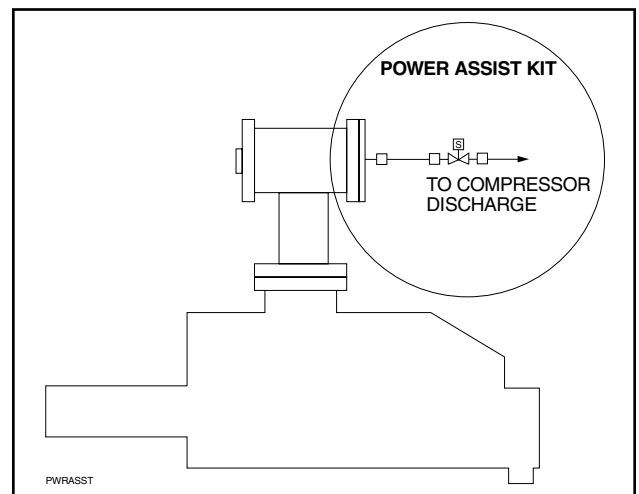

**Figure 25**

## INITIAL START-UP

Initial start-up must be performed under the supervision of a FRICK authorized start-up representative to prevent voiding the compressor warranty. Prior to the start-up, the prestart check (see list in FORMS section) must be accomplished.

### INITIAL START-UP PROCEDURE

Having performed the checkpoints on the prestart check list the compressor unit is ready for start-up. It is important that an adequate refrigerant load be available to load test the unit at normal operating conditions. The following points should be kept in mind during initial start-up.

1. For proper and safe operation the compressor must be run at the proper speed and discharge pressure. Exceeding design conditions creates a potential hazard.
2. Rotate and lubricate motor bearings according to manufacturer's recommendations PRIOR to start-up as required.
3. On units with prelube system a differential pressure of 55 PSI between suction and discharge pressures must be achieved within five minutes of start-up or the unit will shut-down on "Comp. Differential".
4. After running the unit for approximately three hours, adjust liquid injection oil cooling if applicable. If unit has thermosyphon or water cooled oil cooling, adjust water control valve to cooler.

The compressor slide valve and slide stop potentiometers should be calibrated.

5. Stop the unit, lock out the motor main disconnect, check the hot alignment, and adjust as necessary.

### NORMAL START-UP PROCEDURE

1. Confirm system conditions permit starting the compressor.
2. Press the **[RUN]** key.
3. Allow the compressor to start-up and stabilize. Press the **[AUTO]** key immediately below the V ratio label on the operating display screen. Press the **[AUTO]** key immediately below the SV POS label on the operating display. The compressor is now operating in the automatic mode.
4. Observe the compressor unit for mechanical tightness of the external piping, bolts and valves. Ensure that the machine is clean from oil and refrigerant leaks. If any of these occur, shutdown the compressor and correct the problem as necessary using good safety precautions.
5. RETIGHTEN MANWAY BOLTS at condenser design pressure (while system is running).

### RESTARTING COMPRESSOR UNIT AFTER CONTROL POWER INTERRUPTION (PLANT POWER FAILURE)

1. Check variable setpoints.
2. Follow normal start-up procedure.

## Maintenance

### GENERAL INFORMATION

This section provides instructions for normal maintenance, a recommended maintenance program, troubleshooting and correction guides, and typical P and I diagrams. For typical wiring diagrams and control panel information, consult S90-010 M (*Quantum* panel) or S70-200 OM (*Plus* panel).



**THIS SECTION MUST BE READ AND UNDERSTOOD BEFORE ATTEMPTING TO PERFORM ANY MAINTENANCE OR SERVICE TO THE UNIT.**

### NORMAL MAINTENANCE OPERATIONS

When performing maintenance you must take several precautions to ensure your safety:



1. IF UNIT IS RUNNING, PRESS STOP KEY.
2. DISCONNECT POWER FROM UNIT BEFORE PERFORMING ANY MAINTENANCE.
3. WEAR PROPER SAFETY EQUIPMENT WHEN COMPRESSOR UNIT IS OPENED TO ATMOSPHERE.
4. ENSURE ADEQUATE VENTILATION.
5. TAKE NECESSARY SAFETY PRECAUTIONS REQUIRED FOR THE REFRIGERANT BEING USED.



**CLOSE ALL COMPRESSOR PACKAGE ISOLATION VALVES PRIOR TO SERVICING THE UNIT. FAILURE TO DO SO MAY RESULT IN SERIOUS INJURY.**

### GENERAL MAINTENANCE

Proper maintenance is important in order to assure long and trouble-free service from your screw compressor unit. Some areas critical to good compressor operation are:

1. Keep refrigerant and oil clean and dry, avoid moisture contamination. After servicing any portion of the refrigeration system, evacuate to remove moisture before returning to service. Water vapor condensing in the compressor while running, or more likely while shut down, can cause rusting of critical components and reduce life.
2. Keep suction strainer clean. Check periodically, particularly on new systems where welding slag or pipe scale could find its way to the compressor suction. Excessive dirt in the suction strainer could cause it to collapse, dumping particles into the compressor.
3. Keep oil filters clean. If filters show increasing pressure drop, indicating dirt or water, stop the compressor and change filters. Running a compressor for long periods with high filter pressure drop can starve the compressor for oil and lead to premature bearing failure.
4. Avoid slugging compressor with liquid refrigerant. While screw compressors are probably the most tolerant to ingestion of some refrigerant liquid of any compressor type available today, they are not liquid pumps. Make certain to maintain adequate superheat and properly size suction accumulators to avoid dumping liquid refrigerant into compressor suction.
- Keep liquid injection valves properly adjusted and in good condition to avoid flooding compressor with liquid. Liquid can cause a reduction in compressor life and in extreme cases can cause complete failure.
5. Protect the compressor during long periods of shut down. If the compressor will be setting for long periods without running it is advisable to evacuate to low pressure and charge with dry nitrogen or oil, particularly on systems known to contain water vapor.
6. Preventive maintenance inspection is recommended any time a compressor exhibits a noticeable change in vibration level, noise or performance.

### COMPRESSOR SHUTDOWN and START-UP

For seasonal or prolonged shutdowns the following procedure should be followed:

1. Reduce the system pressure to the desired condition.
2. Press [STOP] key to cease operation of the compressor.
3. Open disconnect switches for compressor motor and oil pump starters.
4. Turn on oil heater circuit breaker.
5. Close suction and discharge service valves, also liquid injection and economizer service valves, if applicable. **Attach CLOSED TAGS.**
6. Shut off cooling water supply valve to oil cooler, if applicable. **Attach CLOSED TAG.**
7. Protect oil cooler from ambient temperatures below freezing or remove water heads.

To start-up after a seasonal or prolonged shutdown the following procedure should be followed:

1. Any water necessary for the operation of the system that may have been drained or shut off should be restored and turned on. If oil cooler heads were removed, reinstall and remove tags.
2. Open suction and discharge service valves, also liquid injection and economizer service valves, if applicable. Remove tags.
3. Close disconnect switches for compressor, motor and oil pump starters.
4. Turn off oil heater circuit breaker.
5. Perform checkpoints on prestart check list, then start unit.

## GENERAL INSTRUCTIONS FOR REPLACING COMPRESSOR UNIT COMPONENTS.

When replacing or repairing components which are exposed to refrigerant pressure proceed as follows:

1. Push **[STOP]** key on control panel to shutdown unit.
2. Open disconnect switches for compressor and pump motor starters.
3. Close suction and discharge service valves, also liquid injection and economizer service valves, if applicable.
4. **SLOWLY** vent separator to low-side system pressure using the bypass line on the suction trap. **NOTE: Recover or transfer all refrigerant vapor, in accordance with local ordinances, before opening to atmosphere.** The separator **MUST** be equalized to atmospheric pressure.
5. Make replacement or repair.
6. Isolate the low pressure transducer, PE-4, to prevent damage during pressurization and leak test.
7. Pressurize unit and leak test.
8. Evacuate unit.
9. Open suction and discharge service valves, low pressure transducer, and also liquid injection and economizer service valves, if applicable.
10. Close disconnect switches for compressor and oil pump motor starters.
11. Unit is ready to put into operation.
12. Perform checkpoints on prestart check list, then start unit.

## OIL FILTER (OF-1) MAIN SINGLE/DUAL

RWB II compressor units are furnished with one (1) main oil filter (OF-1). A second oil filter (OF-2) is installed as optional equipment to facilitate the changing of the filter cartridge(s) without unit shutdown.

*RWB II compressor units with a prelude oil pump are furnished with one (1) main oil injection filter (OF-1) and one (1) bearing oil filter (OF-3). Secondary oil filters are installed as optional equipment to facilitate the changing of the filter cartridges without unit shutdown.*

**CAUTION** Use of filter elements other than Frick may cause warranty claim may to be denied.

The procedure to change filter cartridge(s) is as follows:

1. If a single oil filter is installed, push **[STOP]** key on QUANTUM panel to shutdown unit, then open disconnect switches for compressor and oil pump motor starters.

If dual oil filters are installed, open the outlet, then inlet service valves of the standby filter.

**CAUTION** Open inlet service valve slowly to prevent a sudden pressure drop which could cause an oil filter differential alarm.

2. Close outlet then inlet service valves of filter being serviced.
3. Open bleed valve and purge pressure from the oil filter cartridge. **NOTE: Recover or transfer all refrigerant vapor, in accordance with local ordinances, before opening to atmosphere.**
4. Remove the plug from the bottom of the filter canister and drain the oil. Remove the canister cover and discard the gasket. Remove the screws securing the filter assembly. Pull the filter assembly from the canister and discard the gasket and the element.
5. Flush the canister with clean Frick refrigeration oil; wipe dry with a clean, lint-free cloth; and replace the plug.
6. Install a new element and tighten the nut on the end plate to 10 ft-lb torque. Then, while holding the nut with a wrench, apply a second nut to act as a lock nut. Replace the gasket and reinstall the filter assembly into canister, securing with screws tightened to 7 ft-lb torque. Fill the canister with new Frick refrigeration oil. Replace the gasket and reinstall the canister cover. Torque cover bolts first to finger tight, then 65 ft-lb, then 130 ft-lb.

**WARNING** DO NOT MIX OILS of different brands, manufacturers, or types. Mixing of oils may cause excessive oil foaming, nuisance oil level cutouts, oil pressure loss, gas or oil leakage and catastrophic compressor failure.

**CAUTION** Use of filter elements other than Frick may cause warranty claim may to be denied.

7. Close purge valve.
8. Open outlet service valve and leak test.
9. Filter is ready to place in service.

## STRAINER - DEMAND OIL PUMP

To clean the full-lube oil pump strainer, the unit must be shut down. The procedure is as follows:

1. Push **[STOP]** key on QUANTUM panel to shut down unit, then open disconnect switches for compressor and oil pump motor starters.
2. Close strainer inlet service valve.
3. Open drain valve located in the strainer cover and drain oil into a container.
4. Remove capscrews securing strainer cover, strainer cover, gasket and element. Retain gasket.
5. Wash element in solvent and blow clean with air.
6. Wipe strainer body cavity clean with a lint-free clean cloth.
7. Replace cleaned element, gasket and reattach cover using retained capscrews.
8. Close drain valve and open strainer inlet service valve.
9. Check for leakage.
10. Close disconnect switches for compressor and oil pump motor starters.
11. Start unit.

## STRAINER - LIQUID INJECTION

To clean the liquid injection strainer the unit must be shut down. The procedure is as follows:

1. Push **[STOP]** key on microprocessor panel to shutdown unit, then open disconnect switches for compressor and oil pump motor starters.
2. Close liquid supply service valve located before liquid solenoid.
3. **Immediately screw in the manual solenoid valve stem to relieve liquid refrigerant pressure trapped between the solenoid and the service valve.**

**WARNING** Excessive pressure from expanding refrigerant trapped between stop valve and solenoid may cause gasket and O-ring failure and uncontrolled refrigerant release.

4. Close service valve located between the compressor and the liquid injection thermostatic valve.
5. Carefully loosen capscrews securing the strainer cover to the strainer. Allow pressure to relieve slowly.
6. When all entrapped refrigerant has been relieved, carefully remove loosened capscrews (as liquid refrigerant is sometimes caught in the strainer), strainer cover and strainer basket.
7. Wash the strainer basket and cover in solvent and blow clean with air.
8. Reassemble strainer.
9. Open service valve between compressor and liquid injection thermostatic valve and check for leakage.
10. Screw out manual solenoid valve stem.
11. Carefully open liquid supply service valve.
12. Leak test.
13. Close disconnect switches for compressor and oil pump motor starters.
14. Start unit.

## COALESCER FILTER ELEMENT(S)

**CAUTION** Use of filter elements other than Frick may cause warranty claim may to be denied.

When changing the coalescer filter element(s) it is recommended that the oil be changed, cartridge(s) in oil filters OF-1, OF-2, and OF-3 (if applicable) be changed, and the following applicable strainer elements be removed and cleaned.

1. Refer to oil changing Steps 1 through 8.
2. Loosen manway cover retainer bolts, remove retainers, manway cover and cover gasket. Discard cover gasket.
3. Remove and retain nut securing coalescer filter retainer.
4. Remove retainer, coalescer filter element and 2 O-rings. Discard filter elements.
5. Install new coalescer filter element(s).

**CAUTION** Seat element in center of locating tabs on separator bulkhead.

6. Replace coalescer filter retainer and nut. Torque nut to 21 ft-lb. **DO NOT OVERTIGHTEN NUT.**
7. Install a new manway gasket and replace manway cover.
8. Tighten manway bolts. **NOTE: RETIGHTEN AFTER THE COMPRESSOR UNIT IS REPRESSURIZED, SINCE MANWAY BOLTS WILL LOOSEN.**
9. Refer to oil changing Steps 9 through 14.

## CHANGING OIL

**WARNING** DO NOT MIX OILS of different brands, manufacturers, or types. Mixing of oils may cause excessive oil foaming, nuisance oil level cutouts, oil pressure loss, gas or oil leakage and catastrophic compressor failure.

**CAUTION** Use of filter elements other than Frick may cause warranty claim may to be denied.

Shut down the unit when changing oil. At the same time all oil filter cartridges must be changed and all oil strainer elements removed and cleaned. The procedure is as follows:

1. Press the **[STOP]** key on the microprocessor panel to stop the compressor unit.
2. Open the disconnect switch for the compressor motor starter.
3. Close the suction and discharge service valves; also close the liquid-injection and economizer service valves, if applicable.
4. **SLOWLY** vent separator to low-side system pressure using the bypass line on the suction trap. **NOTE: Recover or transfer all refrigerant vapor, in accordance with local ordinances, before opening to atmosphere. The separator MUST be equalized to atmospheric pressure.**

**CAUTION** Oil entrained refrigerant may vaporize, causing a separator pressure increase. Repeat venting and recovery procedure, if necessary.

5. Open the drain valve(s) located on the underside of the separator and drain the oil.
6. Drain the oil filter(s) OF-1 and, if applicable, the oil coolers and filter OF-2.
7. Remove the old filter cartridges, then install new ones (as previously described in the section **OIL FILTER (OF-1) MAIN SINGLE/DUAL**).
8. Remove, clean, and reinstall strainer elements in the strainers.
9. Evacuate the unit to 28" Hg vacuum.
10. Open the suction service valve and pressurize the unit to system suction pressure. Close the suction valve and leak test.

11. Add oil by attaching a suitable pressure-type hose to the oil-charging valve located on top of the separator. Using a pressure-type oil pump and recommended Frick oil, open the charging valve and fill the separator until the oil level is midway in the top sight glass. NOTE: Fill slowly because the oil will fill up in the separator faster than it shows in the sight glass. Refer to the table in the OIL CHARGE section for approximate oil charge quantities.

12. Open the suction and discharge service valves, and also the liquid injection and economizer service valves, if applicable.

13. Close the disconnect switch for the compressor motor starter.

14. Start the unit.

### DEMAND PUMP DISASSEMBLY



**BEFORE OPENING ANY VIKING PUMP LIQUID CHAMBER (PUMPING CHAMBER, RESERVOIR, JACKET, ETC.) ENSURE:**

1. THAT ANY PRESSURE IN THE CHAMBER HAS BEEN COMPLETELY VENTED THROUGH SUCTION OR DISCHARGE LINES OR OTHER APPROPRIATE OPENINGS OR CONNECTIONS.

2. THAT THE DRIVING MEANS (MOTOR, TURBINE, ENGINE, ETC.) HAS BEEN "LOCKED OUT" OR MADE NONOPERATIONAL SO THAT IT CANNOT BE STARTED WHILE WORK IS BEING DONE ON THE PUMP.

**FAILURE TO FOLLOW ABOVE LISTED PRECAUTIONARY MEASURES MAY RESULT IN SERIOUS INJURY OR DEATH.**

1. Mark head and casing before disassembly to ensure proper reassembly. Position the idler pin, which is offset in the pump head, up and equal distance between port connections to allow for proper flow of liquid through the pump.

2. Remove the head capscrews.

3. Tilt top of head back when removing to prevent idler from falling off idler pin.

4. Remove idler and bushing assembly. If idler bushing needs replacing, see **INSTALLATION OF CARBON GRAPHITE BUSHINGS**.

5. Insert a brass bar or piece of hardwood in the port opening and between rotor teeth to keep shaft from turning. Turn the locknut counterclockwise and remove locknut. See Figure 26 or 27.

6. Loosen two setscrews in face of bearing housing and turn thrust bearing assembly counterclockwise and remove from casing. See Figure 26 or 27.

7. **GG, HJ, HL:** Remove snap ring from shaft. See Figure 26. **AS, AK, AL:** Remove bearing spacer from shaft. See Figure 27.

8. Remove brass bar or piece of hardwood from port opening.

9. The rotor and shaft can now be removed by tapping on end of shaft with a lead hammer or, if using a regular hammer, use a piece of hardwood between shaft and hammer. The rotary member of the seal will come out with rotor and shaft.

10. **AS, AK, AL:** Remove bearing retainer washer. The washer may have stayed with rotor and shaft when removed or is against ball bearing. See Figure 27.

11. Remove the mechanical seal rotary member and spring from rotor and shaft assembly.

12. **GG, HJ, HL:** Remove inner snap ring and single-row ball bearing from casing.

**AS, AK, AL:** Remove single-row ball bearing from casing.

13. Remove seal seat or stationary part of seal from casing.

14. Disassemble thrust-bearing assembly.

**GG, HJ, HL:** Remove outer snap ring from bearing housing and remove ball bearing. See Figure 26.

**AS, AK, AL:** Loosen two set screws in flange outside diameter. Rotate end cap and lip seal counterclockwise and remove. Remove ball bearing. See Figure 27.

The casing should be examined for wear, particularly in the area between ports. All parts should be checked for wear before pump is put together.

When making major repairs, such as replacing a rotor and shaft, it is advisable to also install a new mechanical seal, head and idler pin, idler, and bushing. See **INSTALLATION OF CARBON GRAPHITE BUSHINGS**.

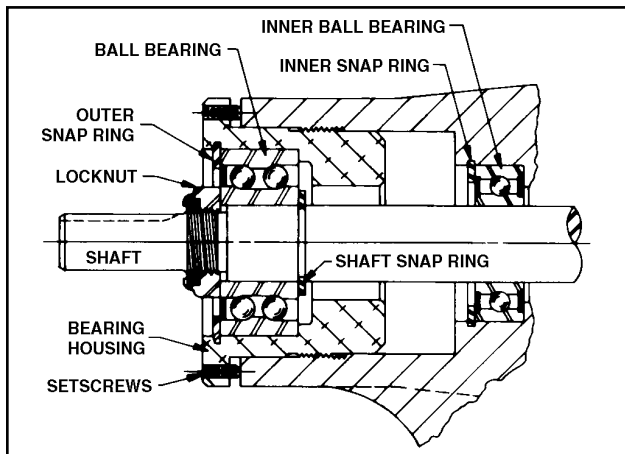

Figure 26 - Thrust-Bearing assembly (GG, HJ, HL)

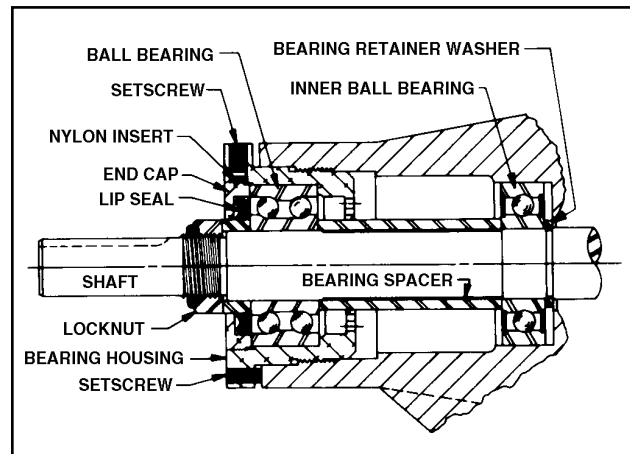

Figure 27 - Thrust-Bearing assembly (AS, AK, AL)

Clean all parts thoroughly and examine for wear or damage. Check lip seals, ball bearings, bushing, and idler pin and replace if necessary. Check all other parts for nicks, burrs, excessive wear and replace if necessary.

Wash bearings in clean solvent and blow out with compressed air. Do not allow bearings to spin; turn them slowly by hand. Spinning bearings will damage race and balls. Make sure bearings are clean, then lubricate with refrigeration oil. Check for roughness by turning outer race by hand and replace bearings if they have roughness.

Be sure shaft is free from nicks, burrs and foreign particles that might damage mechanical seal. Scratches on shaft in seal area will provide leakage paths under mechanical seal. Use fine emery cloth to remove scratches or sharp edges.

### DEMAND PUMP ASSEMBLY

Assembly Notes On Standard Mechanical Seal (Synthetic Rubber Bellows Type)

**NOTE: Read carefully before reassembling pump**

The seal used in this pump is simple to install and good performance will result if care is taken during installation.

The principle of mechanical seal is contact between the rotary and stationary members. These parts are lapped to a high finish and their sealing effectiveness depends on complete contact.

Prior to installing rotary portion of mechanical seal, prepare and organize rotor shaft, head and idler assemblies and appropriate gaskets for quick assembly

Once rotary portion of mechanical seal is installed on rotor shaft, it is necessary to assemble parts as quickly as possible to ensure that the seal does not stick to shaft in wrong axial position. The seal will stick to the shaft after several minutes setting time.

Never touch sealing faces with anything except clean hands or clean cloth. Minute particles can scratch the seal faces and cause leakage.

1. Coat idler pin with refrigeration oil and place idler and bushing on idler pin in head. If replacing a carbon-graphite bushing, refer to "Installation of Carbon Graphite Bushings".

2. Clean rotor hub and casing seal housing bore. Make sure both are free from dirt and grit. Coat outer diameter of seal seat and inner diameter of seal housing bore with refrigeration oil.

3. Start seal seat in seal housing bore. If force is necessary, protect seal face with a clean cardboard disc and

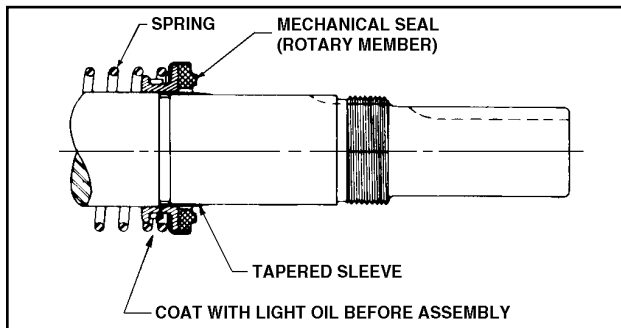

Figure 28

gently tap it in place with a piece of wood. Be sure seal seat is completely seated in the bore.

4. Place tapered installation sleeve on shaft. Refer to Figure 28. Sleeve is furnished with GG, AS, AK, and AL replacement mechanical seals. Coat rotor shaft, tapered installation sleeve, and inner diameter of mechanical seal rotary member with a generous amount of refrigeration oil. Petrolatum may be used but grease is not recommended.

5. Place seal spring on shaft against rotor hub. Refer to Figure 29.

6. Slide rotary member, with lapped contact surface facing away from spring, over installation sleeve on shaft until just contacting the spring. Do not compress spring. Remove installation sleeve.

7. Coat rotor shaft with refrigeration oil. Install shaft slowly pushing until the ends of rotor teeth are just below the face of the casing.

8. Leave the rotor in this position. Withdrawal of rotor and shaft may displace the carbon seal rotating face and result in damage to the seal.

9. Place O-ring gasket on head and install head and idler assembly on pump. Pump head and casing were marked before disassembly to ensure proper reassembly. If not, be sure idler pin, which is offset in pump head, is positioned up and equal distance between port connections to allow for proper flow of liquid through pump.

10. Tighten head capscrews evenly

11. Pack inner ball bearing with multipurpose grease, NLGI #2.

**GG, HJ, HL:** Install bearing in casing with sealed side towards head end of pump. Drive the bearing into the bore. Tap the inner race with a brass bar and lead hammer to position bearing. Install inner snap ring.

**AS, AK, AL:** Install bearing retainer washer over the shaft before installing ball bearing. Install ball bearing in casing with sealed side towards head end of pump. Drive the bearing into the bore. Tap the inner race with a brass bar and lead hammer to position bearing.

12. **GG, HJ, HL:** Install shaft snap ring in groove in the shaft. See Figure 26.

**AS, AK, AL:** Install bearing spacer over shaft and against single row ball bearing. See Figure 27.

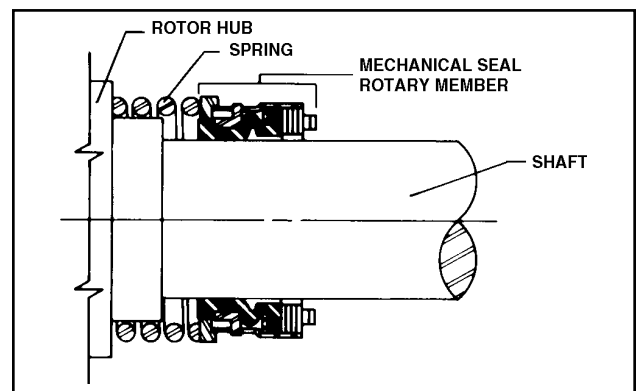

Figure 29

**13. Pack lubrication chamber between** inner ball bearing and double-row ball bearing in the thrust-bearing assembly approximately one-half full of multipurpose grease, NLGI #2. The thrust-bearing assembly will take the remaining space. See Figure 26 and 27.

**14.** Pack double-row ball bearing with multipurpose grease, NLGI #2.

**GG, HJ, HL:** Install ball bearing into bearing housing with shield side toward coupling end of shaft. See Figure 26. Install snap ring into bearing housing to retain ball bearing. This snap ring has a tapered edge to fit tapered groove in bearing housing. The tapered edge is located away from ball bearing.

**AS, AK, AL:** Install ball bearing into bearing housing. Install lip seal in bearing housing end cap. The lip should face towards end of shaft. Put bearing spacer collar in lip seal and install in bearing housing and tighten setscrews securely. See Figure 27.

**15.** Insert brass bar or hardwood through port opening between rotor teeth to keep shaft from turning.

**16.** Start thrust-bearing assembly into casing. Turn by hand until tight. This forces rotor against head. Replace and tighten locknut or shaft.

**17.** Remove brass bar or hardwood from port opening.

**18.** Adjust pump end clearance.

**⚠ DANGER** BEFORE STARTING PUMP, ENSURE THAT ALL DRIVE EQUIPMENT GUARDS ARE IN PLACE. FAILURE TO PROPERLY MOUNT GUARDS MAY RESULT IN SERIOUS INJURY OR DEATH.

### THRUST BEARING ADJUSTMENT

See Figures 26 and 27.

Loosen two screws in face of thrust-bearing assembly.

If shaft cannot be rotated freely, turn thrust-bearing assembly counterclockwise until shaft can be turned easily.

**1.** While turning rotor shaft, rotate thrust-bearing assembly clockwise until noticeable drag occurs. This is zero end clearance.

**2.** Mark position of bearing housing with respect to the casing.

**3.** Rotate thrust-bearing assembly counterclockwise the distance listed below as measured on outside of bearing housing.

**4.** Tighten two setscrews in face of bearing housing after adjustment is made to secure thrust-bearing assembly position.

For viscosities above 2500 SSU, add additional end clearance (0.004" for GG, HJ and HL size pumps and 0.005" for AS, AK and AL size pumps).

Pump Size	Distance (in.) on O.D. of Bearing Housing	End Clearance (in.)
GG	7/16	.003
HJ, HL	9/16	.003
AS, AK, AL	1/2	.003

### INSTALLATION OF CARBON GRAPHITE BUSHINGS

When installing carbon graphite bushings, extreme care must be taken to prevent breaking. Carbon graphite is a brittle material and easily cracked. If cracked, the bushing will quickly disintegrate. Using a lubricant and adding a chamfer on the bushing and the mating part will help in installation. The additional precautions listed below must be followed for proper installation:

1. A press must be used for installation.
2. Be certain bushing is started straight.
3. Do not stop pressing operation until bushing is in proper position. Starting and stopping will result in a cracked bushing.
4. Check bushing for cracks after installation.

### TROUBLESHOOTING THE DEMAND PUMP



**BEFORE OPENING ANY PUMP LIQUID CHAMBER (PUMPING CHAMBER, RESERVOIR, JACKET ETC.) ENSURE:**

**1. THAT ANY PRESSURE IN CHAMBER HAS BEEN COMPLETELY VENTED THROUGH SUCTION OR DISCHARGE LINES OR OTHER APPROPRIATE OPENINGS OR CONNECTIONS.**

**2. THAT THE DRIVING MEANS (MOTOR, TURBINE, ENGINE, ETC.) HAS BEEN "LOCKED OUT" OR MADE NONOPERATIONAL SO THAT IT CANNOT BE STARTED WHILE WORK IS BEING DONE ON PUMP.**

**FAILURE TO FOLLOW ABOVE LISTED PRECAUTIONARY MEASURES MAY RESULT IN SERIOUS INJURY OR DEATH.**

Mark valve and head before disassembly to ensure proper reassembly.

If trouble does develop, one of the first steps toward finding the difficulty is to *install a vacuum gauge in the suction port and a pressure gauge in the discharge port*. Readings on these gauges often will give a clue as to where to start looking for the trouble.

#### Vacuum Gauge—Suction Port

1. High reading would indicate:
  - a. Suction line blocked - foot valve stuck, gate valve closed, strainer plugged.
  - b. Liquid too viscous to flow through the piping.
  - c. Lift too high.
  - d. Line too small.
2. Low reading would indicate:
  - a. Air leak in suction line.
  - b. End of pipe not in liquid.
  - c. Pump is worn.
  - d. Pump is dry - should be primed.
3. Fluttering, jumping, or erratic reading:
  - a. Liquid vaporizing.
  - b. Liquid coming to pump in slugs - possibly an air leak or insufficient liquid above the end of the suction pipe.
  - c. Vibrating from cavitation, misalignment, or damaged parts.

**Pressure Gauge - Discharge Port**

1. High reading would indicate:
  - a. High viscosity and small and/or long discharge line.
  - b. Gate valve partially closed.
  - c. Filter plugged.
  - d. Vertical head did not consider a high specific gravity liquid.
  - e. Line partially plugged from buildup on inside of pipe.
  - f. Liquid in pipe not up to temperature.
  - g. Liquid in pipe has undergone a chemical reaction and has solidified.
  - h. Relief valve set too high.
2. Low reading would indicate:
  - a. Relief valve set too low
  - b. Relief valve poppet not seating properly.
  - c. Too much extra clearance.
  - d. Pump worn.
3. Fluttering, jumping, or erratic reading:
  - a. Cavitation.
  - b. Liquid coming to pump in slugs.
  - c. Air leak in suction line.
  - d. Vibrating from misalignment or mechanical problems.

**Some of the following may also help pinpoint the problem:**

1. Pump does not pump.
  - a. Lost its prime - air leak, low level in tank.
  - b. Rotating in wrong direction.
  - c. Motor does not come up to speed.
  - d. Suction and discharge valves not open.
  - e. Strainer clogged.
  - f. Relief valve set too low, relief valve poppet stuck open.
  - g. Pump worn out.
  - h. Any changes in the liquid system, or operation that would help explain the trouble, e.g. new source of supply, added more lines, inexperienced operators, etc.
  - i. Tighten end clearance.
  - j. Head position incorrect.
2. Pump starts, then loses its prime.
  - a. Low level in tank.
  - b. Liquid vaporizing in the suction line.
  - c. Air leaks or air pockets in the suction line; leaking air through packing or mechanical seal.
  - d. Worn out.
3. Pump is noisy
  - a. Pump is being starved (heavy liquid cannot get to pump fast enough). Increase suction pipe size or reduce length.
  - b. Pump is cavitating (liquid vaporizing in the suction line). Increase suction pipe size or reduce length; if pump is above the liquid, raise the liquid level closer to the pump; if the liquid is above the pump, increase the head of liquid.
  - c. Check alignment.
  - d. May have a bent shaft or rotor tooth. Straighten or replace.
  - e. May be a foreign object trying to get into the pump through the suction port.

4. Pump not up to capacity
  - a. Starving or cavitating - increase suction pipe size or reduce length.
  - b. Strainer partially clogged - clean.
  - c. Air leak in suction piping or along pump shaft.
  - d. Running too slowly - is motor the correct speed and is it wired up correctly
  - e. Relief valve set too low or stuck open.
  - f. Pump worn out.
  - g. Tighten end clearance.
  - h. Head position incorrect.
5. Pump takes too much power.
  - a. Running too fast - is correct motor speed, reducer ratio, sheave size, etc. being used.
  - b. Liquid more viscous than unit sized to handle - heat the liquid, increase the pipe size, slow the pump down, or get a bigger motor.
  - c. Discharge pressure higher than calculated - check with pressure gauge. Increase size or reduce length of pipe, reduce speed (capacity), or get bigger motor.
  - d. Pump misaligned.
  - e. Extra clearance on pumping elements may not be sufficient for operating conditions. Check parts for evidence of drag or contact in pump and increase clearance where necessary
6. Rapid Wear.
 

Examination of a pump that has gradually lost its ability to deliver capacity or pressure would show a smooth wear pattern on all parts. Rapid wear shows up as heavy grooving, galling, twisting, breaking, or similar severe signs of trouble.

**PREVENTATIVE MAINTENANCE**

Performing a few preventative maintenance procedures will extend the life of your pump and reduce the cost per gallon pumped.

**1. Lubrication** - Grease all zerks after every 500 hours of operation or after 60 days, whichever occurs first. If service is severe, grease more often. Do it gently with a hand gun. Use #2 ball bearing grease for normal applications. For hot or cold applications, use appropriate grease.

**2. Packing Adjustment** - Occasional packing adjustment may be required to keep leakage to a slight weep; if impossible to reduce leakage by gentle tightening, replace packing or use different type. See Technical Service Manual on particular model series for details on repacking.

**3. End Clearance Adjustment** - After long service the running clearance between the end of the rotor teeth and the head may have increased through wear to the point where the pump is losing capacity or pressure. Resetting end clearance will normally improve pump performance. See Technical Service Manual on particular model series for procedure on adjusting end clearance for the pump involved.

## RECOMMENDED MAINTENANCE PROGRAM

In order to obtain maximum compressor unit performance and ensure reliable operation, a regular maintenance program should be followed.

The compressor unit should be checked daily for leaks, abnormal vibration, noise, and proper operation. A log should also be maintained. There should be continued monitoring of oil quality and oil analysis testing. In addition, an analysis of the unit's vibration should be periodically made.

### VIBRATION ANALYSIS

Periodic vibration analysis can be useful in detecting bearing wear and other mechanical failures. If vibration analysis is used as a part of your preventive maintenance program, take the following guidelines into consideration.

1. Always take vibration readings from exactly the same places and at exactly the same percentage of load.
2. Use vibration readings taken from the new unit at start-up as the base line reference.
3. Evaluate vibration readings carefully as the instrument range and function used can vary. Findings can be easily misinterpreted.
4. Vibration readings can be influenced by other equipment operating in the vicinity or connected to the same piping as the unit.

## MOTOR BEARINGS

Follow the motor manufacturer's maintenance recommendations. See Figure 30.

**Make sure the motor bearings are properly lubricated before start-up as required by the motor manufacturer.**

### OIL QUALITY and ANALYSIS



High quality refrigeration oil is necessary to ensure compressor longevity and reliability. Oil quality will rapidly

deteriorate in refrigeration systems containing moisture, air, or other contaminants. In order to ensure the quality of the refrigeration oil in the compressor unit.



**DO NOT MIX OILS of different brands, manufacturers, or types. Mixing of oils may cause excessive**

**oil foaming, nuisance oil level cutouts, oil pressure loss, gas or oil leakage and catastrophic compressor failure.**

**NOTE: The Frick oil charge shipped with the unit is the best suited lubricant for the conditions specified at the time of purchase. If there is any doubt due to the refrigerant, operating pressures, or temperatures, refer to Frick Oil publication E160-802 SPC for guidance.**

1. Only use Frick filter elements or warranty claim may be denied.
2. Participate in a regular, periodic oil analysis program to maintain oil and system integrity.

## LUBRICATION SCHEDULE / INSTRUCTIONS

SYNC. RPM	FRAME SERIES	SERVICE CYCLE* - BALL BEARING**	
		8 HR/DAY OPERATION	24 HR/DAY OPERATION
3600	360-5800	150 DAYS (1200 HRS)	50 DAYS (1200 HRS)
1800	360	390 DAYS (3120 HRS)	130 DAYS (3120 HRS)
	400-440	270 DAYS (2160 HRS)	90 DAYS (2160 HRS)
	5000-5800	210 DAYS (1680 HRS)	70 DAYS (1680 HRS)
1200	360-440	390 DAYS (3120 HRS)	130 DAYS (3120 HRS)
	5000-5800	270 DAYS (2160 HRS)	90 DAYS (2160 HRS)

- LUBRICATE BEARINGS WITH POWER IN THE OFF CONDITION.
- CLEAR AND CLEAN THE GREASE FITTINGS AND SURROUNDING AREA.
- REMOVE THE PIPE PLUG FROM THE VENTING PORT OPPOSITE THE GREASE FITTING.
- USING A LOW PRESSURE GREASE GUN APPLY 2 OZS. (60 GRAMS) OF GREASE AT EACH FITTING. DO NOT OVERGREASE.
- WITH THE VENT PORTS OPEN, OPERATE THE MOTOR FOR A MINIMUM OF 15 MINUTES AND UNTIL ANY GREASE FLOW HAS CEASED AT THE VENTING PORTS.
- REMOVE POWER.
- REPLACE THE VENT PIPE PLUGS.
- REPLACE ANY AND ALL GUARDS AND COVERS THAT MAY HAVE BEEN REMOVED TO ACCESS THE MOTOR.

\* LUBRICATION SCHEDULE FOR SEVERE SERVICE (VIBRATION, SHOCK AND/OR ENVIRONMENTAL EXTREME) = 1/3 OF THE ABOVE INTERVALS.

\*\* LUBRICATION SCHEDULE FOR ROLLER BEARINGS = 1/3 OF ABOVE INTERVALS.

THE FACTORY INSTALLED, RECOMMENDED LUBRICANT IS LISTED ON THE MOTOR DATA PLATE. THIS IS A POLYUREA GREASE, AS ARE THE PRODUCTS LISTED BELOW. THE INTRODUCTION OF LUBRICANTS OF ALTERNATE CHEMICAL MAKEUP IS NOT RECOMMENDED AND WILL CAUSE MECHANICAL FAILURE WITHOUT THE COMPLETE PURGE OF THE FACTORY PRODUCT FROM THE BEARING AND RESERVOIR. WHEREVER POSSIBLE, APPLY THE POLYUREA PRODUCT.

CHEVRON OIL CO. - SRI#2      EXXON CORP. - POLYREX EM      SHELL OIL CO. - DOLIUM R

Figure 30

**OPERATING LOG**

The use of an operating log, as included in this manual, permits thorough analysis of the operation of a refrigeration system by those responsible for its maintenance and servicing. Continual recording of gauge pressures, temperatures, and other pertinent information, enables the observer and serviceman to be constantly familiar with the operation of the system and to recognize immediately any deviations from normal operating conditions. It is recommended that readings be taken at least every four hours. See Table of Contents for "OPERATING LOG SHEET".

**MAINTENANCE SCHEDULE**

This schedule should be followed to ensure trouble-free operation of the compressor unit.

MAINTENANCE	HOURS OPERATION (MAXIMUM)																					
	200	1000	5000	8000	10000	15000	20000	25000	30000	35000	40000	45000	50000	55000	60000	65000	70000	75000	80000	85000	90000	95000
CHANGE OIL	As directed by oil analysis																					
OIL ANALYSIS		■	Then every 6 months																			
CHANGE FILTERS	■		■		■		■		■		■		■		■		■		■		■	
CLEAN OIL STRAINERS	■		■		■		■		■		■		■		■		■		■		■	
CLEAN LIQUID STRAINERS	■		■		■		■		■		■		■		■		■		■		■	
CHANGE COALESCERS									■						■						■	
CHECK AND CLEAN SUCTION SCREEN	■	■	■		■		■		■		■		■		■		■		■		■	
CHECK ALIGNMENT	■		■		■		■		■		■		■		■		■		■		■	
CHECK COUPLING	■		■		■		■		■		■		■		■		■		■		■	
VIBRATION ANALYSIS	■	Every 6 months, more frequently if levels increase																				
REPLACE SEAL	When leak rate exceeds 7 - 8 drops per minute																					

## TROUBLESHOOTING GUIDE

Successful problem solving requires an organized approach to define the problem, identify the cause, and make the proper correction. Sometimes it is possible that two relatively obvious problems combine to provide a set of symptoms that can mislead the troubleshooter. Be aware of this possibility and avoid solving the “wrong problem”.

### ABNORMAL OPERATION ANALYSIS and CORRECTION

Four logical steps are required to analyze an operational problem effectively and make the necessary corrections:

1. Define the problem and its limits.
2. Identify all possible causes.
3. Test each cause until the source of the problem is found.
4. Make the necessary corrections.

The first step in effective problem solving is to define the limits of the problem. If, for example, the compressor periodically experiences high oil temperatures, do not rely on this observation alone to help identify the problem. On the basis of this information the apparent corrective measure would appear to be a readjustment of the liquid injection system. Lowering the equalizing pressure on the thermal expansion valve would increase the refrigerant feed and the oil temperature should drop.

If the high oil temperature was the result of high suction superheat, however, and not just a matter of improper liquid injection adjustment, increasing the liquid feed could lead to other problems. Under low load conditions the liquid injection system may have a tendency to overfeed. The high suction superheat condition, moreover, may only be temporary. When system conditions return to normal the units' liquid injection will overfeed and oil temperature will drop. In solving the wrong problem a new problem was created.

When an operating problem develops compare all operating information on the MAIN OPERATING SCREEN with normal operating conditions. If an Operating Log has been maintained the log can help determine what constitutes normal operation for the compressor unit in that particular system.

The following list of abnormal system conditions can cause abnormal operation of the RWB II compressor unit:

1. Insufficient or excessive refrigeration load.
2. Excessively high suction pressure.
3. Excessively high suction superheat.
4. Excessively high discharge pressure.
5. Inadequate refrigerant charge or low receiver level.
6. Excessively high or low temperature coolant to the oil cooler.
7. Liquid return from system (slugging).
8. Refrigerant underfeed or overfeed to evaporators.
9. Blocked tubes in water cooled oil cooler from high mineral content of water.
10. Insufficient evaporator or condenser sizing.
11. Incorrect refrigerant line sizing.
12. Improper system piping.

13. Problems in electrical service to compressor unit.

14. Air and moisture present in the system.

Make a list of all deviations from normal plant operation and normal compressor unit operation. Delete any items which do not relate to the symptom and separately list those items that might relate to the symptom. Use the list as a guide to further investigate the problem.

The second step in problem solving is to decide which items on the list are possible causes and which items are additional symptoms. High discharge temperature and high oil temperature readings on a display may both be symptoms of a problem and not casually related. High suction superheat or a low receiver level, however, could cause both symptoms.

The third step is to identify the most likely cause and take action to correct the problem. If the symptoms are not relieved move to the next item on the list and repeat the procedure until you have identified the cause of the problem. Once the cause has been identified and confirmed make the necessary corrections.

### SERVICING THE COLD-START VALVE



**DO NOT ATTEMPT TO SERVICE THE COLD START VALVE. PLEASE CONTACT THE FRICK SERVICE DEPARTMENT.**

### PRESSURE TRANSDUCERS - TESTING

Pressure transducers, Figure 31, are located on a covered manifold near the microprocessor console.

1. Shut down the compressor and allow pressures to equalize.
2. Isolate suction transducer PE-4 from the unit and depressurize. **NOTE: Recover or transfer all refrigerant vapor, in accordance with local ordinances, before opening to atmosphere.**
3. Measure the voltage of PE-4 on connector P4 (terminals WHT and BLK) on the SBC with a digital voltmeter.
4. The voltage reading should be 1.48 VDC to 1.72 VDC at standard atmospheric pressure (14.7 PSIA or 0 PSIG). When checking transducers at higher elevations, an allowance in the readings must be made by subtracting approximately 0.02 VDC per 1000 feet of elevation above sea level. Therefore, if PE-4 is measured at 5000 feet elevation under relatively normal weather conditions, the output voltage should differ by 0.10 VDC to read between 1.38 VDC and 1.62 VDC.

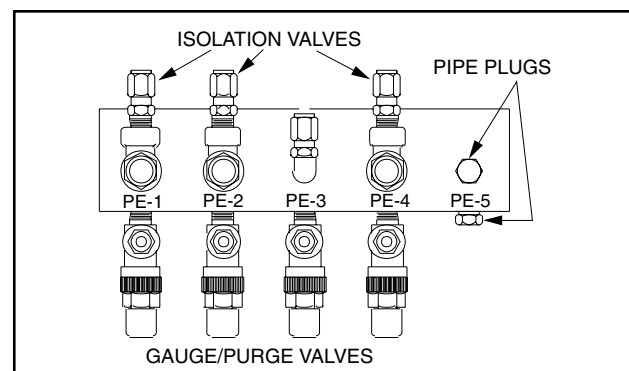

Figure 31

5. Isolate the oil pressure transducer PE-1 from the package and open it to atmosphere.
6. Measure the voltage of PE-1 on connector P4 (terminals WHT and BLK) on the SBC.
7. The voltage reading should be between 1.1 VDC and 1.29 VDC at standard atmospheric pressure. PE-1, PE-2, and PE-3 all have a span of 300 PSI as compared to PE-4 with a span of 100 PSI. Therefore, atmospheric pressure changes have a lesser effect which is 0.0067 VDC per 1000 feet of elevation and 0.00067 VDC per 0.1 inch Hg barometric deviation.
8. Isolate transducer PE-2 from the package and depressurize. **NOTE: Recover or transfer all refrigerant vapor, in accordance with local ordinances, before opening to atmosphere.**
9. Measure the voltage of PE-2 on connector P4 (terminals WHT and BLK) on the SBC.
10. The voltage reading should be between 1.1 VDC and 1.29 VDC at standard atmospheric pressure (see Step 12).
11. Since the discharge pressure, PE-3, cannot be closed off from its sensing point (code requirements), close all transducers from atmosphere and open them to their sensing points so all transducers can equalize to separator pressure.
12. Measure the voltage of PE-3 on connector P4 (terminals WHT and BLK) on the SBC.
13. Measure the voltage of PE-1 on connector P4 (terminals WHT and BLK) on the SBC.
14. These two voltages should be within .04 VDC of one another.
15. Test is complete.

**PRESSURE TRANSDUCERS - REPLACEMENT**

1. Shut off control power.
2. Close the applicable transducer isolation valve. **NOTE: To change the discharge pressure transducer (PE-3), it will be necessary to depressurize the entire compressor package. Follow "General Instructions For Replacing Compressor Unit Components" before going to step 3.**
3. Open the microprocessor control panel.
4. Use the chart to identify transducer terminals of the Analog Board (Quantum panel) or SBC Board (Plus panel).

TRANSDUCER	MANIFOLD CONNECTION
Oil Pressure	PE-1
Oil Before Filter (PSID) *	PE-2
Discharge Pressure	PE-3
Suction Pressure	PE-4

\* Used for Full and Cycling pumps and ext. oil cooler.

5. Disconnect transducer leads by loosening the terminal screws for the transducer to be changed.
6. Tape a 3 ft. length of pull wire to the leads of the transducer to be removed.

PRESSURE TRANSDUCER CONVERSION DATA				
Sensor Voltage	200 psi		500 psi	
	Range - PSI		Range - PSIG*	
	low	high	low	high
1.0	29.92"	9.57"	29.92"	4.10
1.1	29.92"	0.30	29.92"	16.60
1.2	29.92"	5.30	17.10"	29.10
1.3	19.74"	10.30	4.10	41.60
1.4	9.57"	15.30	16.60	54.10
1.5	0.30	20.30	29.10	66.60
1.6	5.30	25.30	41.60	79.10
1.7	10.30	30.30	54.10	91.60
1.8	15.30	35.30	66.60	104.10
1.9	20.30	40.30	79.10	116.60
2.0	25.30	45.30	91.60	129.10
2.1	30.30	50.30	104.10	141.60
2.2	35.30	55.30	116.60	154.10
2.3	40.30	60.30	129.10	166.60
2.4	45.30	65.30	141.60	179.10
2.5	50.30	70.30	154.10	191.60
2.6	55.30	75.30	166.60	204.10
2.7	60.30	80.30	179.10	216.60
2.8	65.30	85.30	191.60	229.10
2.9	70.30	90.30	204.10	241.60
3.0	75.30	95.30	216.60	254.10
3.1	80.30	100.30	229.10	266.60
3.2	85.30	105.30	241.60	279.10
3.3	90.30	110.30	254.10	291.60
3.4	95.30	115.30	266.60	304.10
3.5	100.30	120.30	279.10	316.60
3.6	105.30	125.30	291.60	329.10
3.7	110.30	130.30	304.10	341.60
3.8	115.30	135.30	316.60	354.10
3.9	120.30	140.30	329.10	366.60
4.0	125.30	145.30	341.60	379.10
4.1	130.30	150.30	354.10	391.60
4.2	135.30	155.30	366.60	404.10
4.3	140.30	160.30	379.10	416.60
4.4	145.30	165.30	391.60	429.10
4.5	150.30	170.30	404.10	441.60
4.6	155.30	175.30	416.60	454.10
4.7	160.30	180.30	429.10	466.60
4.8	165.30	185.30	441.60	479.10
4.9	170.30	190.30	454.10	491.60
5.0	175.30	195.30	466.60	504.10
<b>At 0 psig</b>	<b>1.094 V</b>	<b>1.494 V</b>	<b>0.968 V</b>	<b>1.268 V</b>

\* Below 0 PSIG measured in inches of mercury.

7. Pull the transducer leads through the conduit until pull wire extends out of the conduit hole in the transducer manifold. Separate the transducer leads from the pull wire.
8. Unscrew the transducer using a wrench on the metal hex at the base of the transducer. **DO NOT ATTEMPT TO LOOSEN OR TIGHTEN TRANSDUCERS BY THEIR TOP CASING.**
9. Install new transducer and tape leads to the pull wire.
10. Pull new transducer leads into the control panel and reconnect them to the terminal strip. See Analog Board layouts in S90-010 M (Quantum panel) or SBC wiring diagram in S70-200 OM (Plus panel) .
11. Close the microprocessor control panel.
12. Reopen the transducer isolation valve.
13. Turn on control power.

## SV POSITION POTENTIOMETER REPLACEMENT AND ADJUSTMENT

The Slide Valve Position potentiometer is located on the end of the compressor unloader cylinder (see Figure 32).

1. Shut off control power.
2. Remove the four socket head cap screws securing the potentiometer cover to the unloader cylinder.
3. Unsolder leads to the potentiometer and remove.
4. Loosen the setscrew on the potentiometer side of the flexible coupling.
5. Remove the three retainer clips securing the potentiometer to the base plate. The potentiometer should slip out of the coupling.
6. Install the new potentiometer and reassemble.
7. Adjustment:

**ROUGH ADJUSTMENT** is made with the slide valve fully unloaded and the control power off. Remove connector P5. With a digital voltmeter, measure the resistance across the red and white wires, having removed them from the SBC. The resistance should be 1000 +/- 50 ohms. If adjustment is necessary, loosen the locknut and rotate the potentiometer clockwise or counterclockwise until the resistance reading is a close to a 1000 ohms as possible. Retighten the locknut and replace wires. **NOTE: Mechanical travel of the slide valve potentiometer is 300 degrees rotation when the slide stop is confirmed to be in the 2.2 Vi position. The travel will be less than 300 degrees if the slide stop is in any position above 2.2 Vi.**

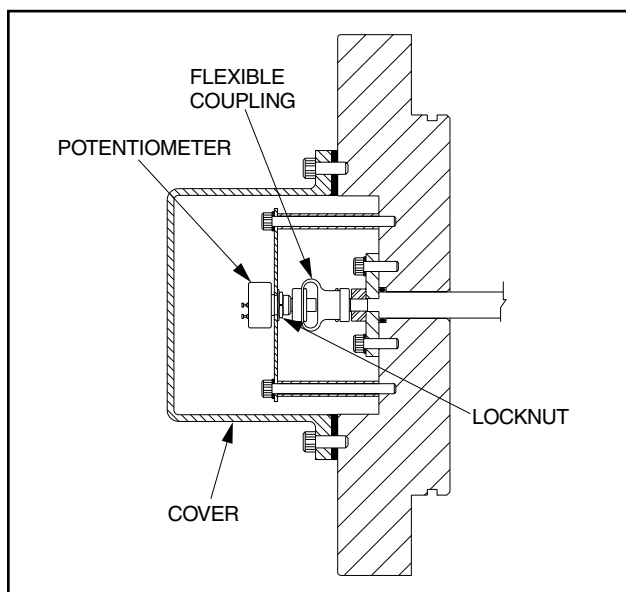

Figure 32

**FINE ADJUSTMENT** must be made with the slide valve fully unloaded and the compressor running. The Operating display at this time should indicate a slide valve position of 0%. If the display is greater than 0%, adjust potentiometer POT #4 on the SBC until 0% is indicated. If 0% is not attainable, get as close as possible and then proceed to the next step. The adjustments of POT #4 and POT #3 are interactive and POT #3 may require adjustment to allow POT #4 to come into range.

Completely load the slide valve. The display at this time should indicate 100%. If the display is less than 100%, adjust potentiometer POT #3 on the SBC until 100% is indicated.

Repeat this sequence until the slide valve indicates 0% fully unloaded and 100% fully loaded.

## VOLUMIZER® POTENTIOMETER REPLACEMENT AND ADJUSTMENT

The VOLUMIZER® potentiometer is located under a cover on the right side of the compressor (facing shaft) at the inlet end. See Figure 33.

1. Shut off control power.
2. Remove the potentiometer cover and gasket.
3. Remove the potentiometer and mounting bracket.
4. Install new potentiometer and bracket.

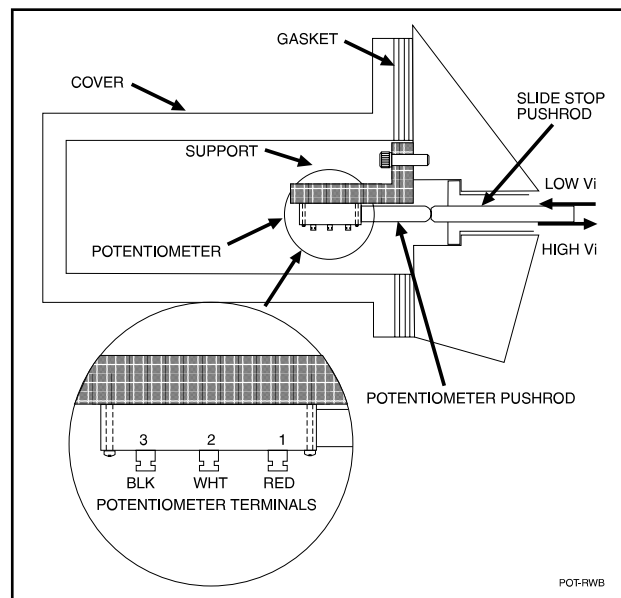

Figure 33

**5. ADJUSTMENT** must be made with the compressor running and the slide valve fully unloaded. With the slide stop at maximum (Vi) position, check that the potentiometer pushrod is in contact with the slide stop pushrod. If not, the bracket must be ground or trimmed until contact is made. Completely decrease the slide stop. The Operating display at this time should indicate a (Vi) of 2.2. If greater than 2.2, adjust potentiometer POT #2 on the SBC until 2.2 is indicated. If 2.2 is not obtainable, get as close as possible and proceed to the next step. Adjustment of POT #2 and POT #1 are interactive and POT #1 may require adjustment to allow POT #2 to come into range. Now, completely increase the slide stop. The display at this time should indicate a (Vi) of 5.0 (4.2 for model 480). If less than 5.0 (4.2 for model 480), adjust potentiometer POT #1 on the SBC until 5.0 (4.2 for model 480) is indicated. Repeat this sequence until the slide stop indicates 2.2 when fully decreased and 5.0 (4.2 for model 480) when fully increased.

**NOTE: The total travel on the VOLUMIZER® potentiometer is .394 inch.**

**TEMPERATURE and/or PRESSURE  
ADJUSTMENT**

All temperature and pressure sensors are factory set. If calibration is required, refer to Analog Calibration for temperature or pressure in S90-010 O (*Quantum* panel) or Analog Offset Display in S70-200 OM (Plus panel).

**OIL LEVEL TRANSMITTER  
REPLACEMENT**

The Oil Level Transmitter is located on the front of the separator near the bottom/center. See Figure 34.

The linear transmitter with hermetic enclosure is based on the capacitive measuring principle. It features removable electronics (from the sensor well) eliminating the need to evacuate the compressor for replacement. This transmitter is dedicated to oil level control and has no user adjustments.

1. Shut off control power.
2. Remove DIN connector plug from transmitter.
3. Loosen set screws.
4. Remove transmitter unit.

5. Install new transmitter unit.
6. Tighten set screws.
7. Apply DIN connector plug to transmitter.
8. Turn on control power.

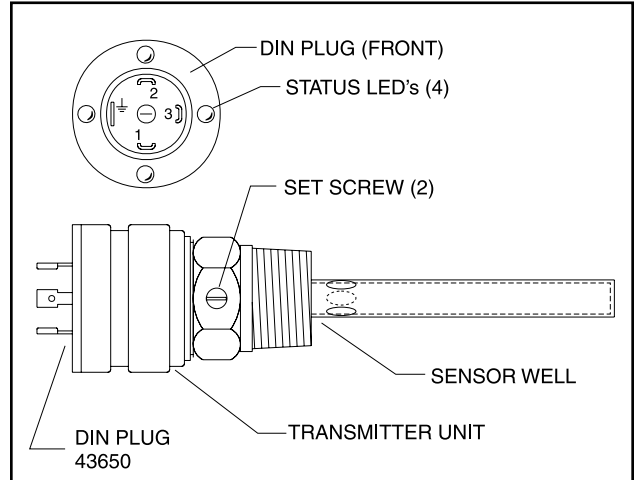

**Figure 34**

**TROUBLESHOOTING THE RWB II COMPRESSOR**

SYMPTOM	PROBABLE CAUSES and CORRECTIONS
EXCESSIVE NOISE and VIBRATION	Main oil injection valve may be closed. Open valve. Bearing damage or excessive wear. CONTACT Frick Factor or Frick. Coupling loose on shaft. Tighten coupling. Replace if damaged. Misalignment between motor and compressor. Realign motor and compressor. Refrigerant flood back. Correct system problem.
SLIDE VALVE and/or SLIDE STOP WILL NOT MOVE	4-way hydraulic control valve failed - repair or replace. Slide stop indicator rod stuck. Contact Frick Factor or Frick for assistance. Check both S.V. and S.S. potentiometer for wiring and resistance. Compressor must be running with sufficient oil pressure. Unloader piston stuck. Contact Frick Factor or Frick for assistance. Slipper seals worn out or damaged. Contact Frick Factor or Frick for assistance.

**NOTE: Troubleshooting the compressor is limited to identifying the probable cause. If a mechanical problem is suspected, contact the Frick Service Department. DO NOT ATTEMPT TO DISASSEMBLE COMPRESSOR.**

### TROUBLESHOOTING THE OIL SEPARATION SYSTEM

SYMPTOM	PROBABLE CAUSES and CORRECTIONS
<p>GRADUAL OIL LOSS WITH AN OIL LEVEL IN THE COALESCER SECTION SIGHT GLASS</p>	<p>Maintaining too high an oil level, lower level.</p> <p>Refrigerant carryover or liquid injection overfeeding, correct operation.</p> <p>Loss of suction superheat. Adjust evaporator feeds.</p> <p>Contaminated oil, damaged or not seated coalescer filter elements. Replace oil charge and coalescers.</p> <p>Oil float return valve closed, open return valve.</p> <p>Float equalizing valve closed, open valve.</p> <p>Coalescing oil return line strainer blocked, clean</p> <p>Clean and check needle valve.</p>
<p>RAPID LOSS WITH NO OIL LEVEL IN THE COALESCER SECTION SIGHT GLASS</p>	<p>On shutdown, compressor unit suction check valve did not close, repair valve.</p> <p>Suction check valve bypass valve open, close valve.</p> <p>Coalescers loose or not seated properly, correct or replace.</p>

### TROUBLESHOOTING THE HYDRAULIC SYSTEM

SYMPTOM	PROBABLE CAUSES and CORRECTIONS
<p>SLIDE VALVE WILL NOT LOAD OR UNLOAD</p>	<p>Solenoid coils may be burned out, replace.</p> <p>Valve may be closed. Open hydraulic service valves.</p> <p>Solenoid spool may be stuck or centering spring broken, replace.</p> <p>Check outputs 2 and 3 and fuses.</p> <p>Solenoid may be mechanically actuated by inserting a piece of 3/16" rod against armature pin and pushing spool to opposite end. Push A side to confirm unload capability. If valve works, problem is electrical.</p>
<p>SLIDE VALVE WILL LOAD BUT WILL NOT UNLOAD</p>	<p>A side solenoid coil may be burned out, replace.</p> <p>Dirt inside solenoid valve preventing valve from operating both ways, clean.</p> <p>Solenoid may be mechanically actuated by inserting a piece of 3/16" rod against armature pin and pushing spool to opposite end. Push A side to confirm unload capability. If valve works, problem is electrical.</p>
<p>SLIDE VALVE WILL UNLOAD BUT WILL NOT LOAD</p>	<p>A side solenoid coil may be burned out, replace.</p> <p>Dirt inside solenoid valve preventing valve from operating both ways, clean.</p> <p>Solenoid may be mechanically actuated by inserting a piece of 3/16" rod against armature pin and pushing spool to opposite end. If valve works, problem is electrical.</p>
<p>SLIDE STOP WILL NOT FUNCTION EITHER DIRECTION</p>	<p>Solenoid coils may be burned out, replace.</p> <p>Solenoid service valves may be closed, open.</p> <p>Manually actuate solenoid. If slide stop will not move mechanical problems are indicated. Consult Frick factor or Frick.</p>

**TROUBLESHOOTING THE LIQUID INJECTION OIL COOLING SYSTEM**

<b>SYMPTOM</b>	<b>PROBABLE CAUSES and CORRECTIONS</b>
HIGH OIL TEMPERATURE	<p>Insufficient liquid supply, check receiver level and pressure drop at injection solenoid.</p> <p>Equalizer pressure too high, lower.</p> <p>Suction superheat too high, correct system problem.</p> <p>Thermal valve power head lost charge, replace.</p> <p>Liquid strainer blocked, clean.</p> <p>Liquid solenoid coil failed, replace.</p> <p>Excessive load. Thermovalve undersized. Reduce load or install larger thermovalve.</p>
LOW OIL TEMPERATURE	<p>Equalizing pressure too low, raise.</p> <p>Suction superheat too low or liquid coming back on compressor, correct system problem.</p> <p>Low load conditions. Valve oversized, increase load or use smaller thermovalve.</p>
OIL TEMPERATURE FLUCTUATES	<p>System conditions rapidly fluctuate causing liquid injection system to over respond, stabilize system operation.</p>

**TROUBLESHOOTING THE DEMAND PUMP SYSTEM**

<b>SYMPTOM</b>	<b>PROBABLE CAUSES and CORRECTIONS</b>
PUMP WILL NOT PRODUCE ENOUGH OIL PRESSURE TO START COMPRESSOR	<p>Check pump rotation.</p> <p>Check that service valves are open.</p> <p>Filter cartridges may be blocked. Check PSID across filters.</p> <p>Strainer may be blocked. Clean.</p> <p>Oil pressure regulator set too low or stuck open. Readjust or repair.</p> <p>Pump worn out. Repair or replace.</p>
OIL PRESSURE RAPIDLY DROPS OFF WHEN COMPRESSOR STARTS RESULTS IN COMPRESSOR DIFFERENTIAL ALARM	<p>Main oil injection throttling valve too wide open or oil pressure regulating valve improperly adjusted. Readjust both valves.</p>
OIL PRESSURE FLUCTUATES	<p>Liquid injection overfeeding or refrigerant flood back from system. Make necessary adjustments or corrections</p>
NOISE and VIBRATION	<p>Pump strainer blocked. Clean.</p> <p>Liquid refrigerant overfeed. Adjust liquid injection.</p> <p>Pump worn out. Repair or replace.</p>
GREASE LEAKS FROM VENT PORT IN THE SIDE OF THE PUMP BODY	<p>Normal leakage which will cease after initial operation. Black oil leaking from this vent indicates oil seal wear or failure. If leakage exceeds normal allowable rate of 7 drops per minute, replace seal.</p>
OIL PRESSURE DROPS AS HEAD PRESSURE INCREASES	<p>Normal behavior. Set main oil injection and oil pressure for maximum head pressure condition.</p>
MAIN FILTER PSID IS TOO HIGH	<p>Filters clogged with dirt. Replace.</p> <p>Oil is too cold. Allow oil to warm up and check again.</p> <p>Service valve on filter outlet is partially closed. Open valves fully.</p>

### THERMAL EXPANSION VALVES

In situations where system load conditions increase or decrease over extended periods of time and the liquid injection thermal expansion valve is not adequate for the new conditions, an improvement in valve performance may be achieved by increasing or decreasing discharge tube size.

**NOTE: DO NOT ATTEMPT TO ADJUST SUPERHEAT ADJUSTMENT STEM ON BOTTOM OF VALVE IN AN EFFORT TO CHANGE THE VALVE'S PERFORMANCE. THIS ADJUSTMENT IS PRESET AT THE FACTORY. ONLY ADJUST 1/4" BLEED VALVE ON EQUALIZING LINE.**

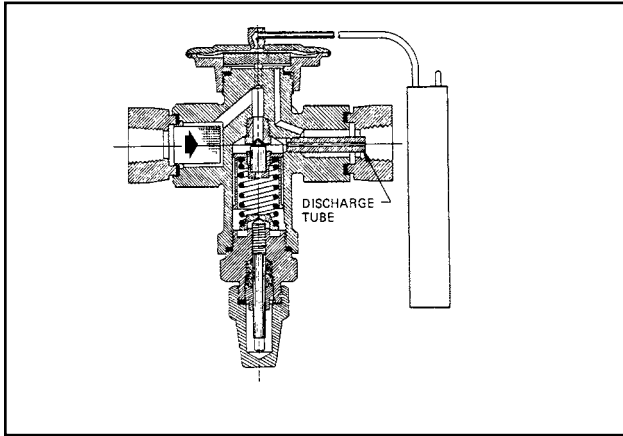

Figure 35 - TYPE D (1-15 TONS) R-717

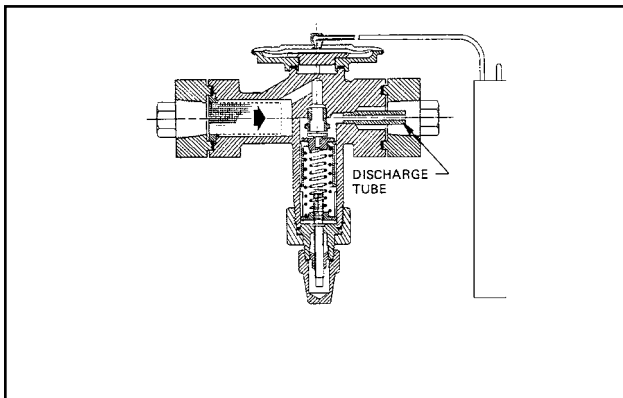

Figure 36 - TYPE A (20-100 TONS) R-717

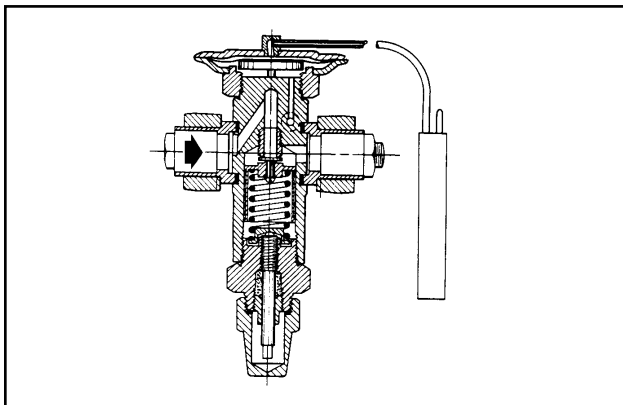

Figure 37 - TYPE H (2-1/2 TO 16 TONS) R-22

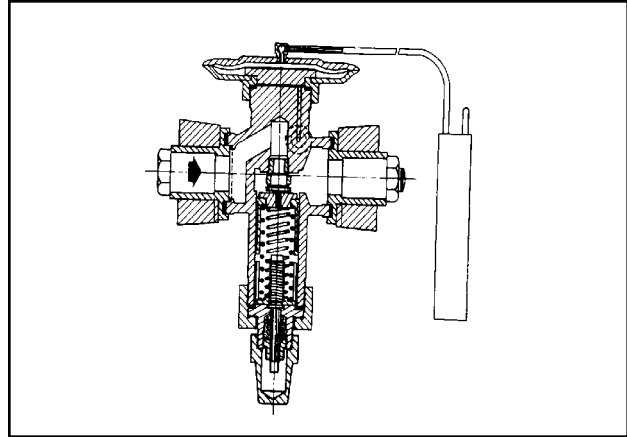

Figure 38 - TYPE M (12 TO 34 TONS) R-22

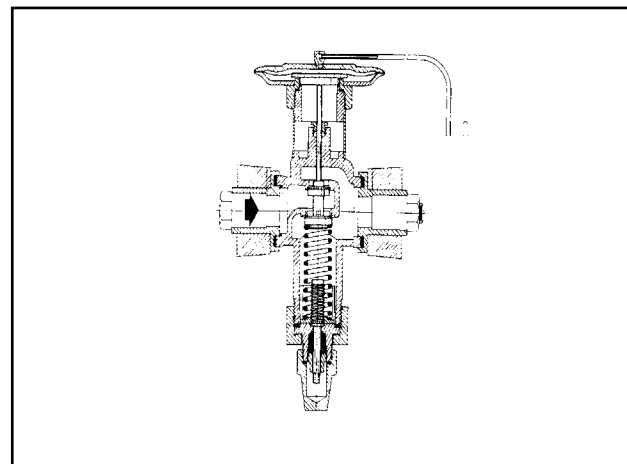

Figure 39 - TYPE V (52 TO 100 TONS) R-22

#### R-717 TX VALVE SIZES

TX VALVE MODE	PORT SIZE	DISCHARGE TUBE SIZE
DAE - 1	1/16	1/32
DAE - 2	1/16	1/16
DAE - 5	7/64	5/64
DAE - 10	3/16	7/64
DAE - 15	3/16	5/32
AAE - 20	5/16	1/8
AAE - 30	5/16	5/32
AAE - 50	3/8	3/16
AAE - 75	3/8	NONE
AAE - 100	7/16	NONE

#### R-22 TX VALVE SIZES

TX VALVE MODE	FPT CONNECTION
HVE - 2-1/2	1/2
HVE - 5-1/2	1/2
HVE - 11	1/2
HVE - 16	1/2
MVE - 12	1
MVE - 21	1
MVE - 34	1
VVE - 52	1
VVE - 70	1
VVE - 100	1

## JORDAN TEMPERATURE REGULATOR VALVE

The Jordan valve is a high volume, temperature-regulating valve that requires minimal differential across the valve to ensure adequate flow for cooling.

The Jordan valve must be mounted on a horizontal line with the flow arrow pointing toward the direction of flow. However, the valve may be mounted at any angle perpendicular to the horizontal line, including inverted, if necessary.



### Sensing Bulb, Vertical Mounting -

When the sensing bulb is to be mounted vertically (pointing down), no special precaution is necessary. If the bulb is to be mounted vertically, in an inverted position, a special capillary is needed because the tip of the sensing bulb is higher than the capillary end.

**Sensing Bulb, Horizontal Mounting -** When mounting the sensing bulb horizontally it must be mounted so that the word "TOP" which is stamped on the capillary end of the bulb appears accordingly. **NOTE: No angular mounting of the sensing bulb is permitted.**

**Adjustment -** To increase the oil temperature, increase the spring tension by turning the knurled nut at the base of the spring. To decrease the oil temperature, decrease the spring tension by turning the knurled nut at the base of the spring (see Figure 40).

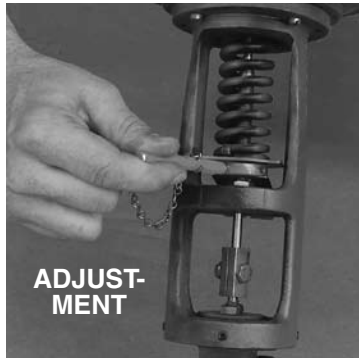

Figure 40

**Action -** The valve should be set as a reverse acting valve, however there are times when the valve may be set as a direct acting valve. If you experience what seems to be a total absence of oil cooling you will need to check the action of the valve. To check the action you will need to remove the cap-flange and disc-guide.



Figure 41

If the hole in the valve plate is to the left and the slot in the valve disc is on the top this valve is set for Direct Acting (see figure 41). To change the action of the valve to Reverse Acting simply rotate the valve plate and the valve disc 180° so that the hole on the plate is on the right and the slot on the disk is at the bottom (see figure 42).

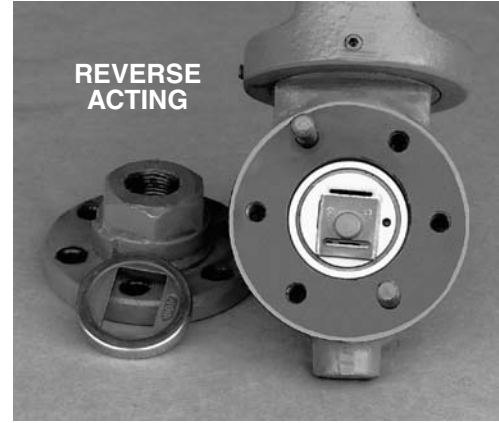

Figure 42

**Stroke Adjustment -** After the valve action has been changed it may be necessary to make a stroke adjustment. This ensures that the full capacity of the valve is available, if necessary, to keep the oil at the predetermined temperature.

To prepare for a stroke adjustment do the following.

- Remove the disc-guide, valve-disc, and valve-plate.
- Expose the sensing bulb in a vertical position to an ambient temperature of about 80°F.
- Release all spring tension by loosening the knurled nut.
- Loosen the disc-pin locking nut and allow at least 10 minutes for the valve to react (see figure 43).

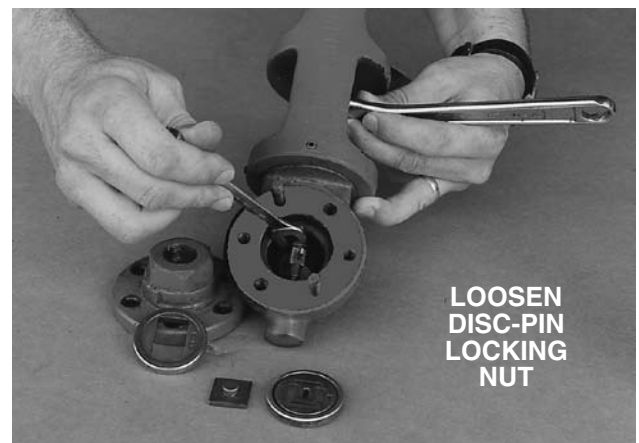

Figure 43

- Rotate the disc-pin so that when the valve-plate is installed the bottom of the pin is between the middle and the bottom of the slot.
- Hold the coupling with a wrench and tighten the disc-pin locking nut.
- Install the valve-plate and valve-disk for reverse action (see figure 42).
- Install the disk-guide and cap-flange.
- Increase the spring tension to about 30% by turning the knurled nut at the base of the spring approximately 20 quarter turns.

Install the valve and adjust the spring tension accordingly to maintain the predetermined oil temperature. The recommended oil temperatures are 130°F for ammonia and 140°F for R-22. Check with Frick service for recommended oil temperatures for other refrigerants.

If all of the above steps have been properly performed and the desired oil temperature can not be achieved, contact Frick Service.

### BARE COMPRESSOR MOUNTING

The following procedure is required only when a bare compressor is replaced in the field.

1. Thoroughly clean the compressor feet and mounting pads of burrs and other foreign matter to ensure firm seating of the compressor.
2. Clean the discharge flange surfaces on the compressor and separator.
3. Install a gasket on the compressor discharge connection of the separator.
4. Set the compressor on its base and tighten the discharge flange bolts. **The feet of the compressor should lift off the mounting base. If the compressor feet do not raise off the mounting base install a thicker discharge gasket and reinstall the discharge flange bolts.** Check the clearance between the feet and the base with a feeler gauge. Shim the compressor feet (gauge reading plus .002").
5. Tighten compressor hold down bolts.
6. Complete compressor/motor coupling alignment (see INSTALLATION section).
7. Complete tubing, piping and wiring per the P & I and wiring diagrams.

### SHUTDOWN DUE TO IMPROPER OIL PRESSURE (HIGH STAGE and BOOSTER)

The compressor must not operate with incorrect oil pressure.

1. For units with *Quantum* Control Panels, refer to CONTROL SETUP - "OIL SETPOINTS DISPLAY" in S90-010 O.

2. For units with *Microprocessor* Control Panels, install a pressure transducer to monitor the pressure of the oil supply to the balance piston. The correct pressure with the solenoid closed is 50 psi below discharge pressure (+/-15 psi). The correct pressure with the solenoid valve open is within 20 psi of oil pressure as measured at the oil manifold.

At 60 psi and less differential pressures, with the solenoid valve closed, the oil pressure should be 1.1 times suction pressure (+/-15 psi). Differential pressure is defined as defined as discharge pressure minus suction pressure.

The shutdown should occur if the condition persists for 2 minutes. For the first 5 minutes after compressor start has been confirmed, this safety shutdown may be ignored.

3. For units with *Electromechanical* Control Panels, a safety shutdown on balance piston oil pressure may be omitted.

### GREASE COMPATIBILITY

If it becomes necessary to mix greases, be careful not to combine different oil bases or thickeners. DO NOT mix a mineral oil-base grease with a synthetic oilbase grease. Also, a grease with a lithium thickener should not be mixed with one containing a sodium thickener. The table illustrates the compatibility of various types of grease based on results by National Lubricating Grease Institute (NLGI). The chart indicates a great variance in compaibility with the greases tested.

NLGI Grease Compatibility Chart

	Aluminum Complex	Barium	Calcium	Calcium 12-hydroxy	Calcium Complex*	Clay	Lithium	Lithium 12-hydroxy	Lithium Complex	Polyurea
Aluminum Complex	-	I	I	C	I	I	I	I	C	I
Barium	I	-	I	C	I	I	I	I	I	I
Calcium	I	I	-	C	I	C	C	B	C	I
Calcium 12-hydroxy	C	C	C	-	B	C	C	C	C	I
Calcium Complex	I	I	I	B	-	I	I	I	C	C
Clay	I	I	C	C	I	-	I	I	I	I
Lithium	I	I	C	C	I	I	-	C	C	I
Lithium 12-hydroxy	I	I	B	C	I	I	C	-	C	I
Lithium Complex	C	I	C	C	C	I	C	C	-	I
Polyurea*	I	I	I	I	C	I	I	I	I	-

B = Borderline Compatibility

C = Compatible

I = Incompatible

\* Standard

**P & I DIAGRAM**

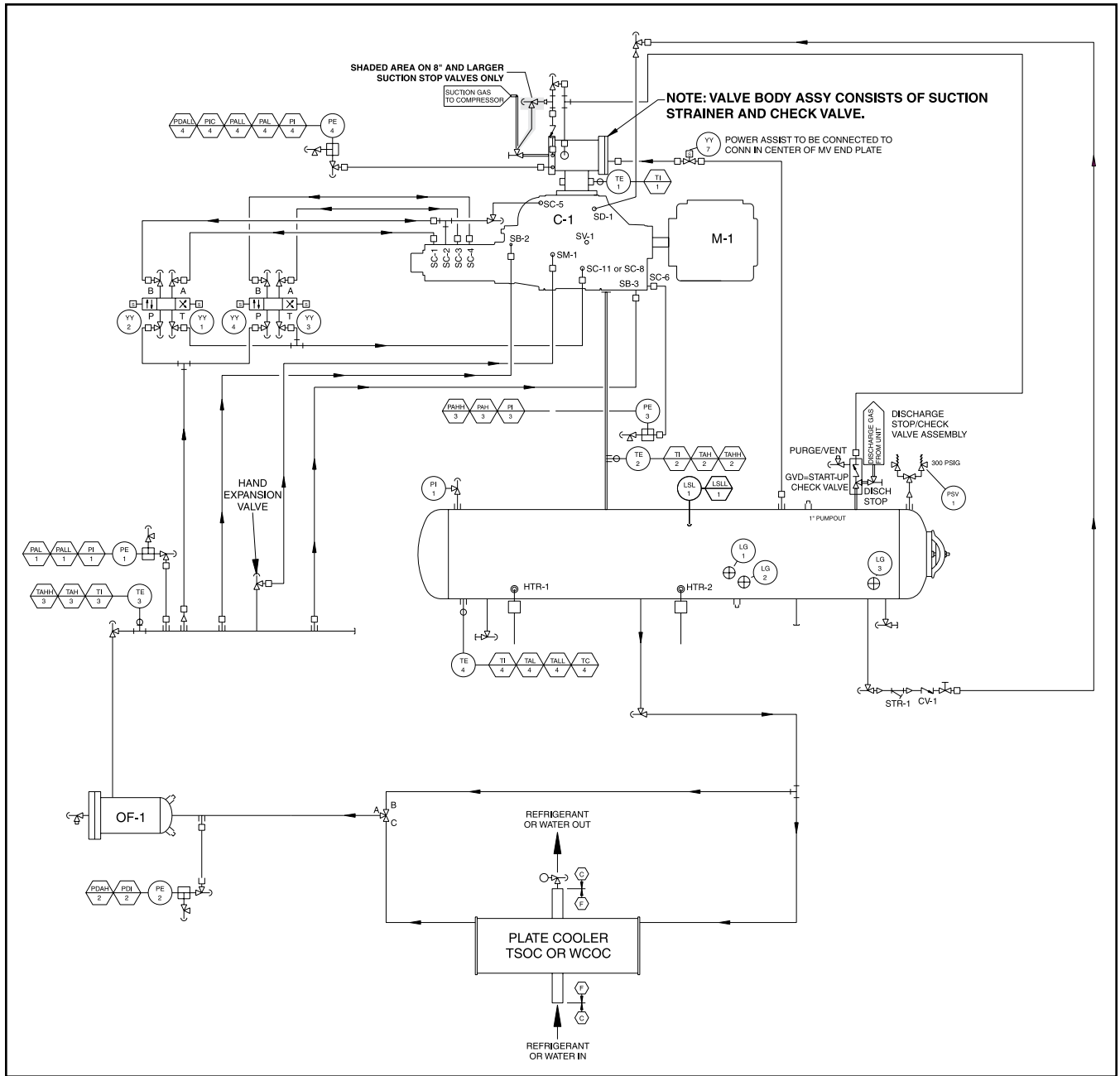



**P & I DIAGRAM, LIQUID INJECTION – SINGLE PORT**

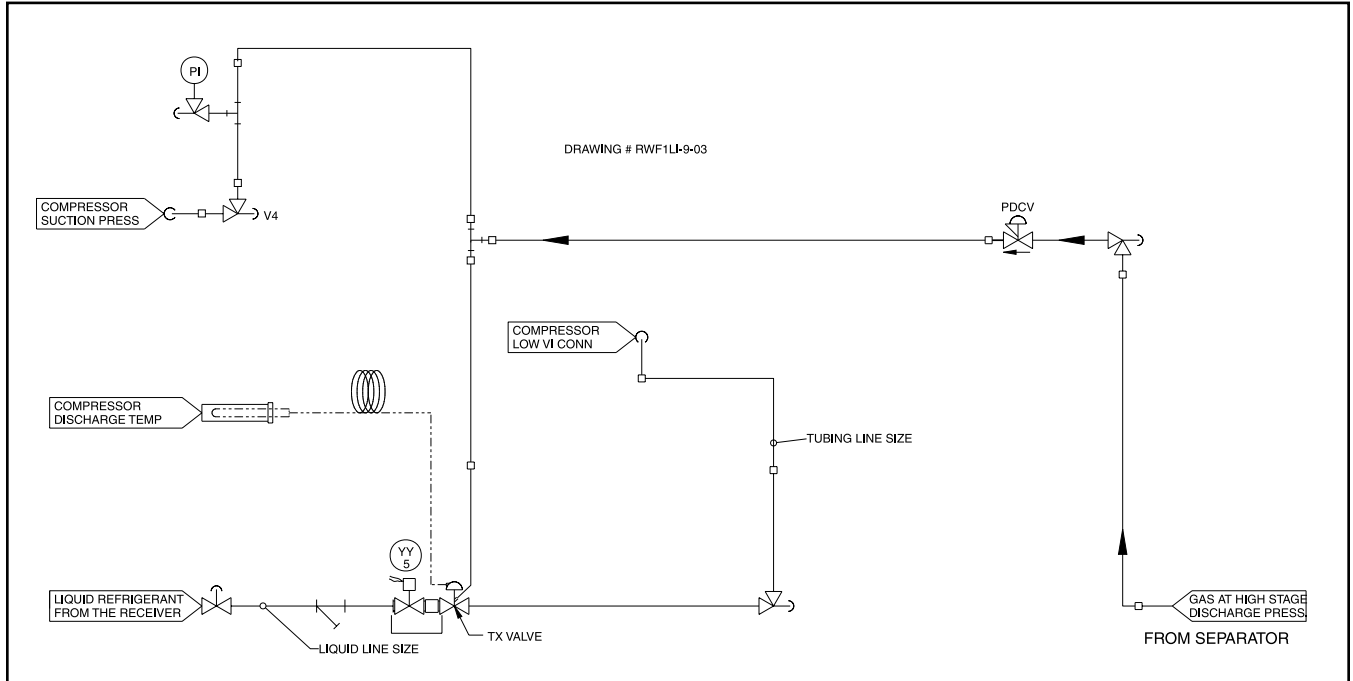

**P & I DIAGRAM, LIQUID INJECTION – DUAL PORT**

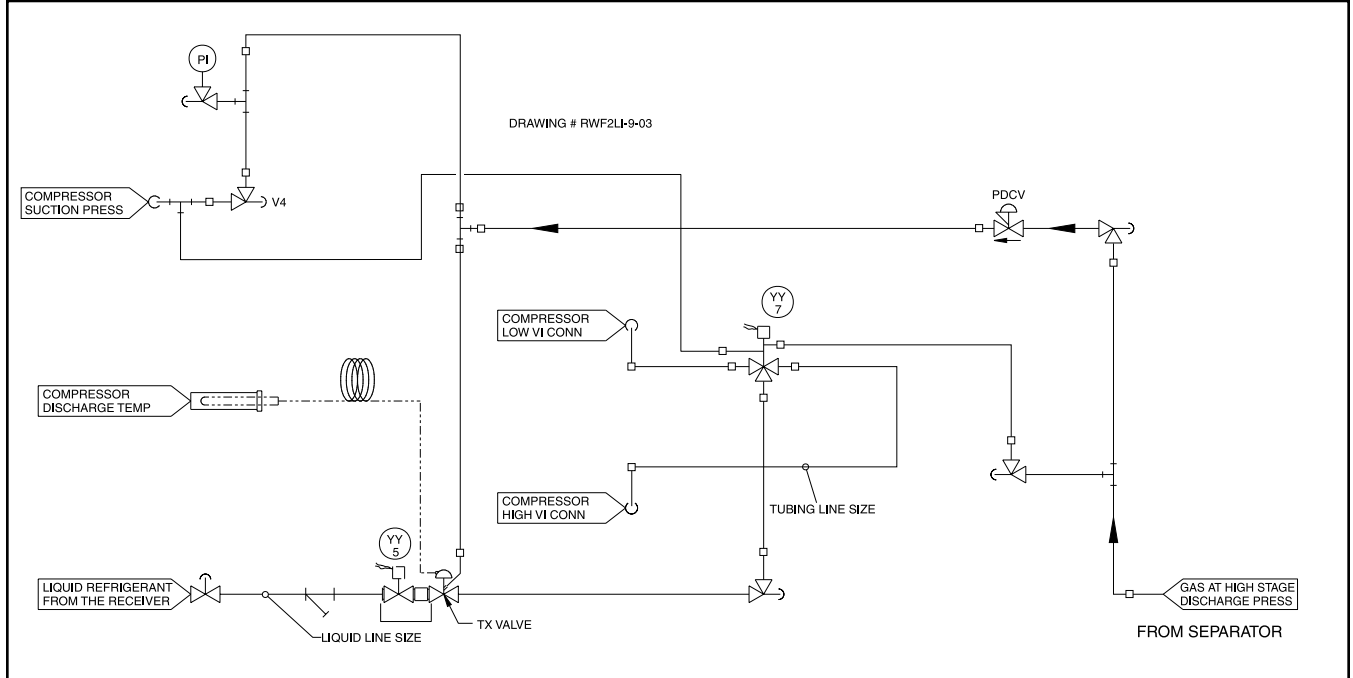

**P & I DIAGRAM, LIQUID INJECTION – BOOSTER**

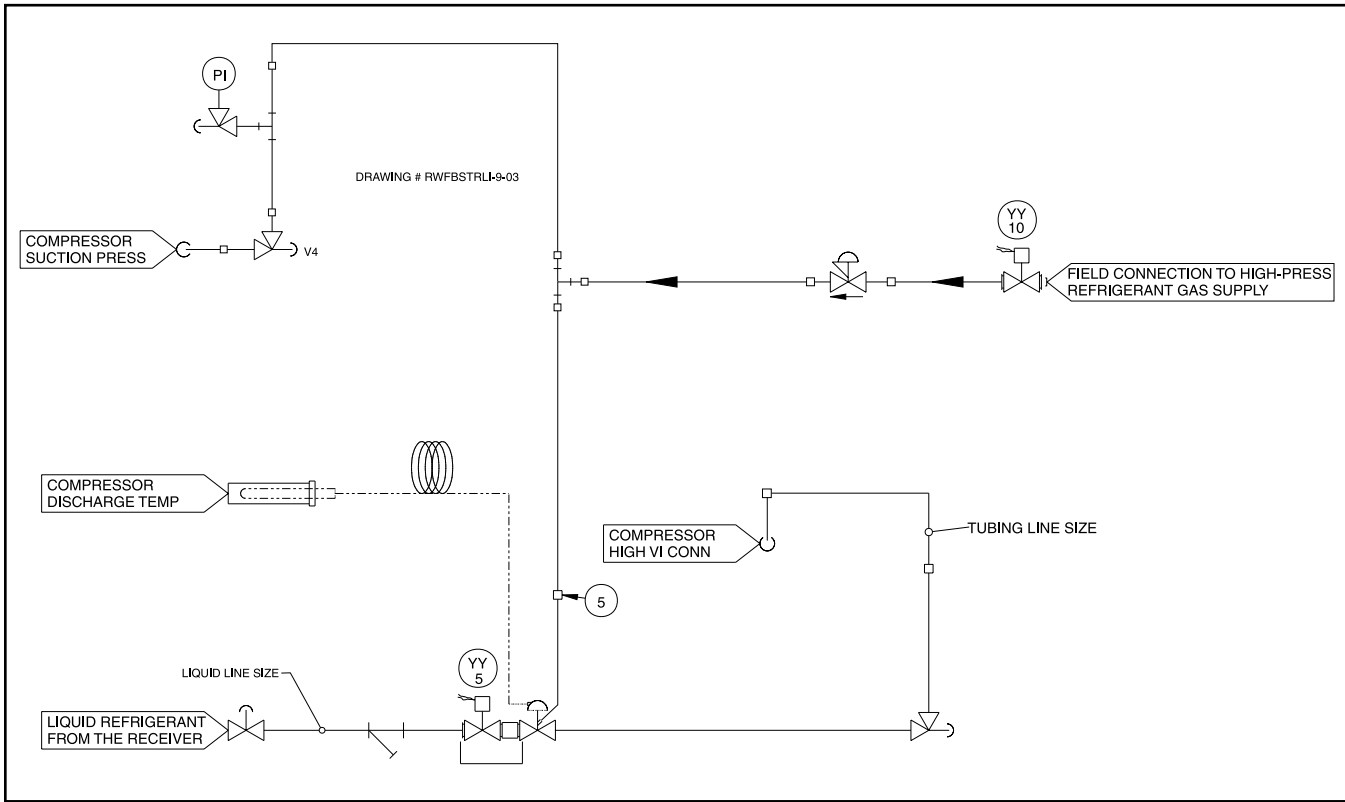

## PROPER INSTALLATION OF ELECTRONIC EQUIPMENT IN AN INDUSTRIAL ENVIRONMENT

In today's refrigeration plants, electronic controls have found their way into almost every aspect of refrigeration control. Electronic controls have brought to the industry more precise control, improved energy savings, and operator conveniences. Electronic control devices have revolutionized the way refrigeration plants operate today.

The earlier relay systems were virtually immune to radio frequency interference (RFI), electromagnetic interference (EMI), and ground loop currents. Therefore installation and wiring were of little consequence and the wiring job consisted of hooking up the point-to-point wiring and sizing the wire properly. In an electronic system, improper installation will cause problems that may outweigh the benefits of electronic control. Electronic equipment is susceptible to RFI, EMI, and ground loop currents which can cause equipment shutdowns, processor memory and program loss, as well as erratic behavior and false readings. Manufacturers of industrial electronic equipment take into consideration the effects of RFI, EMI, and ground loop currents and incorporate protection of the electronics in their designs. However, these design considerations do not make the equipment immune, so manufacturers require that certain installation precautions be taken to protect the electronics from these effects. All electronic equipment must be viewed as sensitive instrumentation and therefore requires careful attention to installation procedures. These procedures are well known to instrumentation, networking, and other professions but may not be followed by general electricians.

There are a few basic practices that if followed, will minimize the potential for problems resulting from RFI, EMI and/or ground loop currents. The National Electric Code (NEC) is a guideline for safe wiring practices, but it does not necessarily deal with procedures used for electronic control installation. Use the following procedures for electronic equipment installation. These procedures do not override any rules by the NEC, but are to be used in conjunction with the NEC code and any other applicable codes.

With exclusion of the three phase wire sizing, Frick drawing 649D4743 should be used as a reference for properly sizing control wires and other wiring specifications.

Throughout this document the term Electronic Control Panel is used to refer to the microprocessor mounted on the compressor package or a Central Control System panel.

**NOTE: It is very important to read the installation instructions thoroughly before beginning the project. Make sure you have drawings and instructions with your equipment. If not, call the manufacturer and request the proper instructions and drawings. Every manufacturer of electronic equipment should have a knowledgeable staff, willing to answer your questions or provide additional information. Following correct wiring procedures will ensure proper installation and consequently, proper operation of your electronic equipment.**

### WIRE SIZING

Control power supply wires should be sized one size larger than required for amperage draw to reduce instantaneous voltage dips caused by large loads such as heaters, contactors, and solenoids. These sudden dips in voltage can cause the electronic control panel, whether it is a microprocessor, a computer, or a PLC, to malfunction momentarily or cause a complete reset of the control system. If the wire is

loaded to its maximum capacity, the voltage dips are much larger, and the potential of a malfunction is very high. If the wire is sized one size larger than required, the voltage dips are smaller than in a fully loaded supply wire and the potential for malfunction is much lower. The NEC code book calls for specific wire sizes to be used based on current draw. An example of this would be to use #14 gauge wire for circuits up to 15 amps or #12 gauge wire for circuits of up to 20 amps. Therefore, when connecting the power feed circuit to an electronic control panel, use #12 gauge wire for a maximum current draw of 15 amp and #10 wire for a maximum current draw of 20 amp. Use this rule of thumb to minimize voltage dips at the electronic control panel.

### VOLTAGE SOURCE

Selecting the voltage source is extremely important for proper operation of electronic equipment in an industrial environment. Standard procedure for electronic instrumentation is to provide a clean, isolated, separate-source voltage in order to prevent EMI (from other equipment in the plant) from interfering with the operation of the electronic equipment. Connecting electronic equipment to a breaker panel (also known as lighting panels or utility panels) subjects the electronic equipment to noise generated by other devices connected to the breaker panel. This noise is known as electromagnetic interference (EMI). EMI flows on the wires that are common to a circuit. EMI cannot travel easily through transformers and therefore can be isolated from selected circuits. Use a control power transformer of the proper VA rating, usually provided in the compressor drive motor starter, to isolate the electronic control panel from other equipment in the plant that generate EMI. See Figure 44.

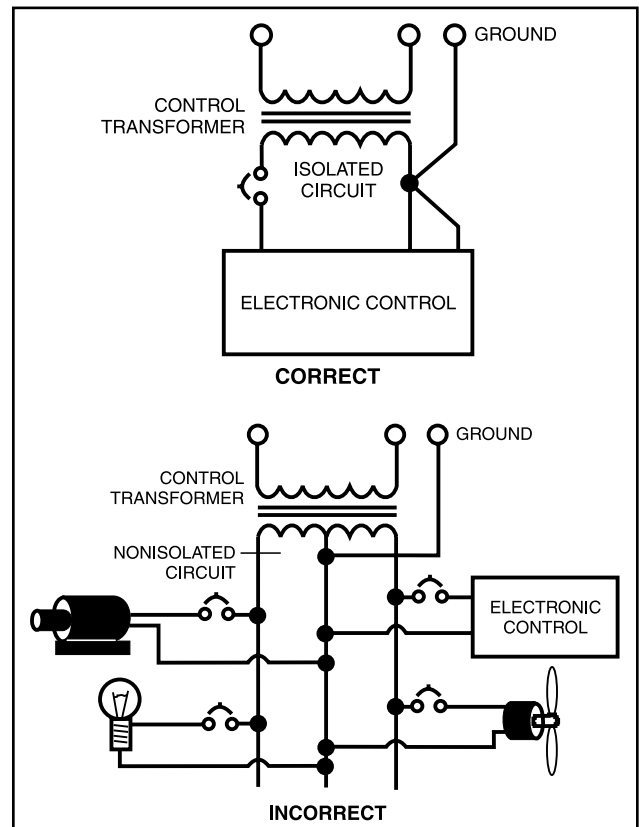

Figure 44

## GROUNDING

Grounding is the most important factor for successful operation and is typically the most overlooked. The NEC states that control equipment may be grounded by using the rigid conduit as a conductor. This worked for the earlier relay systems, but it is in no way acceptable for electronic control equipment. Conduit is made of steel and is a poor conductor relative to an insulated stranded copper wire. Electronic equipment reacts to very small currents and must have a proper ground in order to operate properly; therefore, stranded copper grounds are required for proper operation.

For proper operation, the control power ground circuit must be a single continuous circuit of the proper sized insulated stranded conductor, from the electronic control panel to the plant supply transformer (Figure 45). Driving a ground stake at the electronic control may also cause additional problems since other equipment in the plant on the same circuits may ground themselves to the ground stake causing large ground flow at the electronic control panel. Also, running multiple ground conductors into the electronic control panel from various locations can create multiple potentials resulting in ground loop currents. A single ground wire (10 AWG or 8 AWG) from the electronic control panel, that is bonded to the control power neutral at the secondary side of the control power transformer in the starter and then to the 3-phase ground point, will yield the best results.

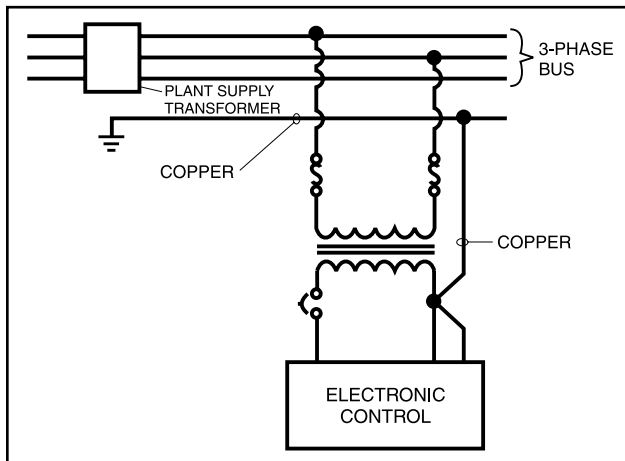

Figure 45

**NOTE: Structural grounding can also result in multiple ground potentials and is also a relatively poor conductor. Therefore, this is not an acceptable method for proper operation of electronic equipment.**

There must be a ground for the three-phase power wiring. This must be sized in accordance to the NEC and any local codes relative to the highest rated circuit overload protection provided in the circuit. The manufacturer may require a larger ground conductor than what is required by the NEC for proper steering of EMI from sensitive circuits. This conductor must also be insulated to avoid inadvertent contact at multiple points to ground, which could create Ground Loops. In many installations that are having electronic control problems, this essential wire is usually missing, is not insulated, or improperly sized.

NEC size ratings are for safety purposes and not necessarily for adequate relaying of noise (EMI) to earth ground to avoid possible interference with sensitive equipment. Therefore sizing this conductor 1 – 2 sizes larger than required by code will provide better transfer of this noise.

Frick requires that the ground conductor meet the following requirements be:

- Stranded Copper
- Insulated
- One size larger than NEC requirements for conventional starters
- Two sizes larger than NEC requirements for VFD starters
- Conduit must be grounded at each end
- This circuit must be complete from the motor to the starter continuing in a seamless manner back to the plant supply transformer (power source).

For Direct Coupled, Package Mounted Starters, the ground between the motor and the starter may need to be made externally (Figure 46). The connection on the starter end must be on the starter side of the vibration isolators. Be certain the connection is metal to metal. Paint may need to be removed to ensure a proper conductive circuit. The use of counter-sunk star washers at the point of connection at each end will maximize metal to metal contact.

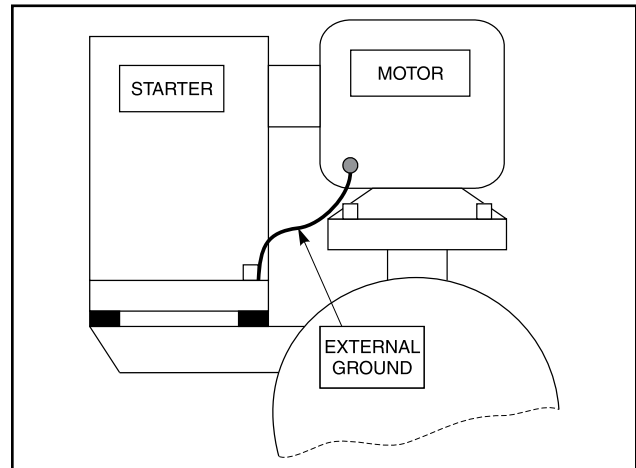

Figure 46

## VFD APPLICATIONS

The primary ground conductor that accompanies the three-phase supply must be stranded copper, insulated and two sizes larger than the minimum required by the NEC or any other applicable codes. This is necessary due to the increased generation of EMI which is a characteristic of a VFD output to the motor when compared to a conventional starter.

For VFD applications, isolation of the control power, analog devices, and communications ground from the 3-phase ground within the starter and the electronic control panel may be necessary. This is due to the higher noise (RFI/EMI) levels generated between the VFD output and the motor, relative to a conventional starter. If these grounds are left coupled

by a common back-plate in the starter/drive, this noise can be direct coupled to the control power, analog device, and communications grounding and may cause unexplained behavior and possible damage to components.

To install correctly, run a separate, properly sized (10 or 8 AWG typically) insulated ground along with and taken to ground with, the 3-phase ground at the 3-phase supply transformer (plant). This will require that the 3-phase ground and the control power ground be electrically isolated except for the connection at the plant supply transformer.

This style of grounding should steer the noise (EMI/RFI) to earth ground, reducing the potential for it to affect the sensitive equipment, which could occur if the grounds were left coupled. **NOTE: If all other recommendations for grounding are followed, this process should not be necessary.**

## CONDUIT

All national and local codes must be followed for conduit with regard to materials, spacing and grounding. In addition, **Johnson Controls-Frick requirements must be followed where they exceed or match national or local codes. Conversely, there is no allowance for any practices that are standard to what is required by national or local codes.**

Johnson Controls-Frick conduit requirements:

- For *variable frequency drives* (VFDs) of any type, threaded metallic or threaded PVC-coated metallic is required for both the power feed (line side) from the source and between the VFD output and the motor (load side).
- PVC conduit is acceptable **only** when *VFD rated cable* of the proper conductor size and ground is used. This applies to both the line side and load side of the drive. When VFD rated cable is not used, threaded metallic or threaded PVC-coated metallic must be used.
- When threaded metallic or threaded PVC-coated metallic is used, it must be grounded at both ends.
- When not required to be in metal or other material by national or local codes, conduits for the power feed (3-phase) of constant speed starters may be PVC.
- When not required to be in metal or other material by national or local codes, conduits between a constant speed starter and the motor (3-phase) may be PVC.
- Any unshielded control voltage, signal, analog, or communication wiring that does not maintain 12 inches of separation from any 3-phase conductors for every 33 feet (10 meters) of parallel run must be in metal conduit which will be grounded.

Separation: (0-33 feet, 0-10 meters – 12 inches, .3 meters), (33-66 feet, 10-20 meters – 24 inches, .6 meters)

- Since PVC conduit does absolutely nothing to protect lower voltage lines from the magnetic field effects of higher voltage conductors, running either the lower or the higher voltage lines in PVC, does not reduce these requirements on separation. Only running in metal conduit can relieve these requirements.
- Due to the level of EMI that can be induced onto lower voltage lines when running multiple feeders in a trench, control power, communications, analog, or signal wiring

cannot be run in trenches that house multiple conduits/ electrical ducts carrying 3-phase power to starters/vfd or motors.

- Control power, communications, analog, or signal wiring should be run overhead (preferred) or in a separate trench. If these lines are not in threaded metallic or threaded PVC-coated metallic, abiding by the separation requirements noted above is necessary.
- Though not recommended, if cable trays are used, *metallic* dividers must be used for separation of conductors of unlike voltages and types (AC or DC).

**NOTE: When in doubt contact the factory or use threaded metallic or threaded PVC coated metallic conduit.**

## WIRING PRACTICES

Do not mix wires of different voltages in the same conduit. An example of this would be the installation of a screw compressor package where the motor voltage is 480 volts and the electronic control panel power is 120 volts. The 480 volt circuit must be run from the motor starter to the motor in its own conduit. The 120 volt circuit must be run from the motor starter control transformer to the electronic control panel in its own separate conduit. If the two circuits are run in the same conduit, transients on the 480 volt circuit will be induced onto the 120 volt circuit causing functional problems with the electronic control panel. Metallic dividers must be used in wire way systems (conduit trays) to separate unlike voltages. The same rule applies for 120 volt wires and 220 volt wires. Also, never run low voltage wires for DC analog devices or serial communications in the same conduit with any AC wiring including 120 volt wires. See Figure 47.

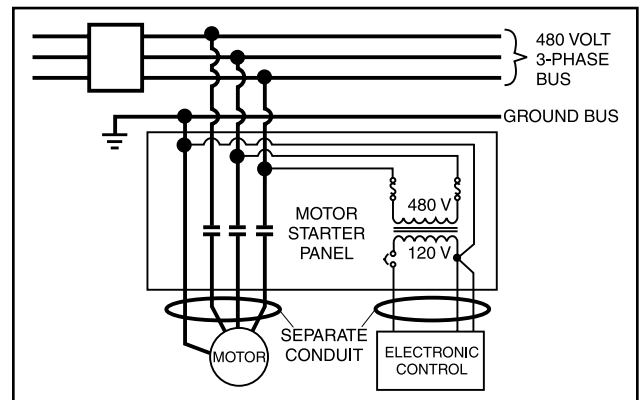

Figure 47

**Never run any wires through an electronic control panel that do not relate to the function of the panel.** Electronic control panels should never be used as a junction box. These wires may be carrying large transients that will interfere with the operation of the control panel. **An extreme example of this would be to run 480 volts from the starter through the electronic control panel to an oil pump motor.**

When running conduit to the electronic control panel, use the access holes (knockouts) provided by the manufacturer. These holes are strategically placed so that the field wiring does not interfere with the electronics in the panel. Never allow field wiring to come in close proximity with the controller boards since this will almost always cause problems.

Do not drill into an electronic control panel to locate conduit connections. You are probably not entering the panel where the manufacturer would like you to since most manufacturers recommend or provide prepunched conduit connections. You may also be negating the NEMA rating of the enclosure. Drilling can cause metal filings to land on the electronics and create a short circuit when powered is applied. If you must drill the panel, take the following precautions:

- First, call the panel manufacturer before drilling into the panel to be sure you are entering the panel at the right place.
- Take measures to avoid ESD (electrostatic discharge) to the electronics as you prep the inside of the Electronic control panel. This can be done by employing an antistatic wrist band and mat connected to ground.
- Cover the electronics with plastic and secure it with masking or electrical tape.
- Place masking tape or duct tape on the inside of the panel where you are going to drill. The tape will catch most of the filings.
- Clean all of the remaining filings from the panel before removing the protective plastic.

When routing conduit to the top of an electronic control panel, condensation must be taken into consideration. Water can condense in the conduit and run into the panel causing catastrophic failure. Route the conduit to the sides or bottom of the panel and use a conduit drain. If the conduit must be routed to the top of the panel, use a sealable conduit fitting which is poured with a sealer after the wires have been pulled, terminated, and the control functions have been checked. A conduit entering the top of the enclosure must have a NEMA-4 hub type fitting between the conduit and the enclosure so that if water gets on top of the enclosure it cannot run in between the conduit and the enclosure. This is extremely important in outdoor applications.

**NOTE: It is simply NEVER a good practice to enter through the top of an electronic control panel or starter panel that does not already have knockouts provided. If knockouts are not provided for this purpose it is obvious this is not recommended and could VOID WARRANTY.**

**Never add relays, starters, timers, transformers, etc. inside an electronic control panel without first contacting the manufacturer.** Contact arcing and EMI emitted from these devices can interfere with the electronics. Relays and timers are routinely added to electronic control panels by the manufacturer, but the manufacturer knows the acceptable device types and proper placement in the panel that will keep interference to a minimum. If you need to add these devices, contact the manufacturer for the proper device types and placement.

**Never run refrigerant tubing inside an electronic control panel.** If the refrigerant is ammonia, a leak will totally destroy the electronics.

**If the electronic control panel has a starter built into the same panel, be sure to run the higher voltage wires where indicated by the manufacturer.** EMI from the wires can interfere with the electronics if run too close to the circuitry.

**Never daisy-chain or parallel-connect power or ground wires to electronic control panels.** Each electronic control panel must have its own control power supply and ground wires back to the power source (Plant Transformer). Multiple electronic control panels on the same power wires create current surges in the supply wires, which may cause controller malfunctions. Daisy-chaining ground wires, taking them to ground at each device, allows ground loop currents to flow between electronic control panels which also causes malfunctions. See Figure 48.

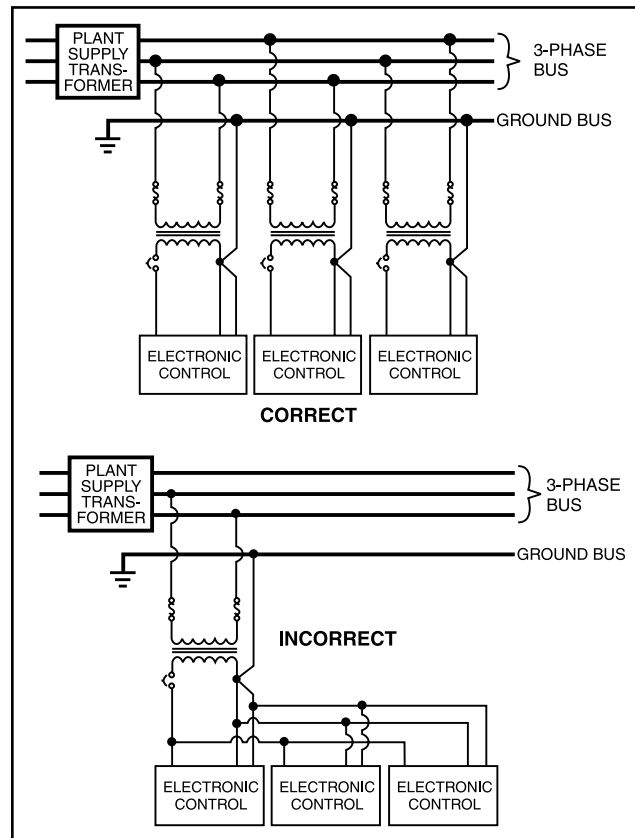

Figure 48

## COMMUNICATIONS

The use of communications such as serial and ethernet in industrial environments are commonplace. The proper installation of these networks is as important to the proper operation of the communications as all of the preceding practices are to the equipment.

Serial communications cable needs to be of the proper gauge based on the total cable distance of the run. Daisy-chaining is the only acceptable style of running the communications cable. While Star Networks may use less cable, they more often than not cause problems and interruptions in communications, due to varying impedances over the varying lengths of cable. Ground or drain wires of the communications cable are to be tied together at each daisy-chain connection and only taken to ground in the central control system panel.

It is important to carefully consider the type of cable to be used. Just because a cable has the proper number of conductors and is shielded does not mean it is an acceptable cable. Frick recommends the use of Belden #9829 for RS-422 communications and Belden # 9841 for RS-485 up to 2000 feet (600 Meters) total cable length. Refer to Frick drawing 649D4743 for more detail

**Comm Port Protection:** Surge suppression for the comm ports may not be the best method, since suppression is required to divert excess voltage/current to ground. Therefore, the success of these devices is dependent on a good ground (covered earlier in this section). This excess energy can be quite high and without a proper ground, it will access the port and damage it.

Isolation or Optical Isolation is the preferred comm port protection method. With optical isolation, there is no continuity between the communications cable and the comm port. There is no dependence on the quality of the ground. Be sure to know what the voltage isolation value of the optical isolator is before selecting it. These may range from 500 to 4000 Volts.

Frick Optical Isolation Kits are offered under part number 639C0133G01. One kit is required per comm port.

## UPS POWER AND QUANTUM™LX PANELS

Johnson Controls, Inc. does not advise nor support the use of uninterrupted power supply systems for use with the Quantum™LX panel. With a UPS system providing shutdown protection for a Quantum panel, the panel may not see the loss of the 3-phase voltage on the motor because the UPS may prevent the motor starter contactor from dropping out. With the starter contactor still energized, the compressor auxiliary will continue to feed an “okay” signal to the Quantum™LX panel. This may allow the motor to be subjected to the fault condition on the 3-phase bus.

A couple of fault scenarios are: 1. The 3-phase bus has power “on” and “off” in a continuous cycle manner which may cause the motor to overheat due to repeated excessive in-rush current experiences. 2. The motor cycling may damage the coupling or cause other mechanical damage due to the repeated high torque from rapid sequential motor “bumps.” 3. Prolonged low voltage may cause the motor to stall and possibly overheat before the motor contactor is manually turned off.

Under normal conditions, the loss of 3-phase power will shut down the Quantum™LX panel and it will reboot upon proper power return. If the panel was in “Auto,” it will come back and return to running as programmed. If the unit was in “Remote,” the external controller will re-initialize the panel and proceed to run as required. If the panel was in “Manual” mode, the compressor will have to be restarted manually after the 3-phase bus fault/interruption has been cleared / restored.

If the local power distribution system is unstable or prone to problems there are other recommendations to satisfy these problems. If power spikes or low or high line voltages are the problem, then a constant voltage (CV) transformer with a noise suppression feature is recommended. Johnson Controls, Inc. can provide these types of transformers for this purpose. Contact Johnson Controls for proper sizing (VA Rating) based on the requirement of the job. If a phase loss occurs, then you will typically get a high motor amp shutdown. If the problem continues, an analysis of the facility’s power supply quality may be necessary.

**NOTE: It is very important to read the installation instructions thoroughly before beginning the project. Make sure you have drawings and instructions for the equipment being installed. If not, call the manufacturer to receive the proper instructions and drawings. Every manufacturer of electronic equipment should have a knowledgeable staff, willing to answer your questions or provide additional information. Following correct wiring procedures will ensure proper installation and consequently, proper operation of your electronic equipment.**



BY JOHNSON CONTROLS

# SCREW COMPRESSOR Operating Log Sheet

Frick Order No. \_\_\_\_\_  
 Compr. Ser. No. \_\_\_\_\_  
 Unit Location \_\_\_\_\_

OPERATING LOG SHEET

Date													
Time													
Hour Meter Reading													
Equipment Room Temp./Outdoor Temp.		/	/	/	/	/	/	/	/	/	/	/	/
Compressor	Suction Pressure												
	Suction Temperature												
	Suction Superheat												
	Discharge Pressure												
	Corresponding Temperature												
	Actual Discharge Temperature												
	Oil Pressure												
	Oil Temperature												
	Oil Filter Press. Drop - DP												
	Slide Valve Position %												
	Volume Ratio (V.I.)												
	FLA %												
Seal Leakage (drops/min)													
Capacity Control Setpoint													
Oil Sep.	Separator Temperature												
	Oil Level (example ● ●)	○ ○	○ ○	○ ○	○ ○	○ ○	○ ○	○ ○	○ ○	○ ○	○ ○	○ ○	○ ○
	Oil Added (gallons)												
Evap.	Brine	Inlet Temperature											
		Outlet Temperature											
		Pressure Drop - DP											
		Flow Rate - GPM											
Condenser	Air	Air On Temperature											
		Air Off Temperature											
	Water	Inlet Temperature											
		Outlet Temperature											
		Pressure Drop - DP											
		Flow Rate - GPM											
	Leaving Liquid Refrigerant Temperature												
Rcvr/Econ	Level												
	Pressure												
Remarks:													

NOTE: Temperature and Pressure Units in °F and PSIG respectively, unless otherwise indicated.

## RWB II COMPRESSOR PRESTART CHECKLIST

The following items **MUST** be checked and completed by the installer prior to the arrival of the Frick Field Service Supervisor. Details on the checklist can be found in this manual. Certain items on this checklist will be reverified by the Frick Field Service Supervisor prior to the actual start-up.

### Mechanical Checks

- Confirm that motor disconnect is open
- Isolate suction pressure transducer
- Pressure test and leak check unit
- Evacuate unit
- Remove compressor drive coupling guard
- Remove coupling center and **DO NOT reinstall** (motor rotation must be checked without center)
- Check for correct position of all hand, stop, and check valves **PRIOR** to charging unit with **OIL** or **REFRIGERANT**
- Charge unit with correct type and quantity of oil
- Lubricate electric drive motor bearings **PRIOR** to checking motor rotation
- Check oil pump alignment (if applicable)
- Check for correct economizer piping (if applicable)
- Check separate source of liquid refrigerant supply (if applicable, liquid injection oil cooling)
- Check water supply for water-cooled oil cooler (if applicable, water cooled oil cooling)
- Check thermosyphon receiver refrigerant level (if applicable, thermosyphon oil cooling)
- Check for **PROPER PIPE SUPPORTS** and correct foundation
- Check to ensure **ALL** piping **INCLUDING RELIEF VALVES** is completed

### Electrical Checks

- Confirm that main disconnect to motor starter and micro is open
- Confirm that electrical contractor has seen this sheet, **ALL PERTINENT WIRING** information, and drawings
- Confirm proper power supply to the starter package
- Confirm proper motor protection (breaker sizing)
- Confirm that all wiring used is stranded copper and is 14 AWG or larger (sized properly)
- Confirm all 120 volt control wiring is run in a separate conduit from all high voltage wiring
- Confirm all 120 volt control wiring is run in a separate conduit from oil pump and compressor motor wiring
- Confirm no high voltage wiring enters the micro panel at any point
- Check current transformer for correct sizing and installation
- Check all point-to-point wiring between the micro and motor starter
- Confirm all interconnections between micro, motor starter, and the system are made and are correct
- Ensure all electrical panels are free from installation debris, **METAL PARTICLES**, and moisture

### After the above items have been checked and verified:

- Close the main disconnect from the main power supply to the motor starter
- Close the motor starter disconnect to energize the micro
- Manually energize oil pump and check oil pump motor rotation
- Manually energize compressor drive motor and check motor rotation
- Leave micro energized to ensure oil heaters are on and oil temperature is correct for start-up

**Summary: The Frick Field Service Supervisor should arrive to find the above items completed. He should find an uncoupled compressor drive unit (to verify motor rotation and alignment) and energized oil heaters with the oil at the proper standby temperatures. Full compliance with the above items will contribute to a quick, efficient and smooth start-up.**

### The Start-up Supervisor will:

1. Verify position of all valves
2. Verify all wiring connections
3. Verify compressor motor rotation
4. Verify oil pump motor rotation
5. Verify the % of FLA on the micro display
6. Verify and finalize alignment (if applicable)
7. Calibrate slide valve and slide stop
8. Calibrate temperature and pressure readings
9. Correct any problem in the package
10. Instruct operation personnel

**NOTE: Customer connections are to be made per the electrical diagram for the motor starter listed under the installation section and per the wiring diagram in the Quantum maintenance manual.**

**Please complete and sign this form & fax to 717-762-8624 as confirmation of completion.**

Frick Sales Order Number: \_\_\_\_\_  
 Compressor Model Number: \_\_\_\_\_  
 Unit Serial Number: \_\_\_\_\_  
 End User Name: \_\_\_\_\_  
 Address of Facility: \_\_\_\_\_  
 City, State, Zip: \_\_\_\_\_

Print Name: \_\_\_\_\_  
 Company: \_\_\_\_\_  
 Job Site Contact: \_\_\_\_\_  
 Contact Phone Number: \_\_\_\_\_  
 Signed: \_\_\_\_\_



## Start-up Report

Frick Order No: \_\_\_\_\_

Sold To: \_\_\_\_\_ Contact Name: \_\_\_\_\_ Date: \_\_\_\_\_  
 End User: \_\_\_\_\_ Contact Name: \_\_\_\_\_ Phone: \_\_\_\_\_  
 End User Address: \_\_\_\_\_ Fax No: \_\_\_\_\_  
 City, State, Zip: \_\_\_\_\_ Start-up Representative \_\_\_\_\_

### Unit General Information

Unit Model # \_\_\_\_\_ Customer Package Identification # \_\_\_\_\_  
 Compressor Serial # \_\_\_\_\_ Separator National Board # \_\_\_\_\_  
 Unit Serial # \_\_\_\_\_ Oil Cooler National Board # \_\_\_\_\_  
 Evaporator National Board # \_\_\_\_\_ Serial # \_\_\_\_\_ Condenser National Board # \_\_\_\_\_ Serial # \_\_\_\_\_  
 Oil Pot National Board # \_\_\_\_\_ H.P. Receiver National Board # \_\_\_\_\_  
 Economizer National Board # \_\_\_\_\_ Suction Accumulator National Board # \_\_\_\_\_  
 Refrigerant \_\_\_\_\_ Oil Filters \_\_\_\_\_ Lube Oil Type \_\_\_\_\_ Design Operating Conditions \_\_\_\_\_  
 Oil Cooling \_\_\_\_\_ ° Suct. / \_\_\_\_\_ ° Disch.

### Micro Information

Micro Type \_\_\_\_\_ Program Software Ver # \_\_\_\_\_ and Date \_\_\_\_\_ UL Serial # \_\_\_\_\_  
 Digital I/O Board #1 Serial # \_\_\_\_\_ Software Ver # \_\_\_\_\_ and Date \_\_\_\_\_  
 Digital I/O Board #2 Serial # \_\_\_\_\_ Software Ver # \_\_\_\_\_ and Date \_\_\_\_\_  
 Analog Board #1 Serial # \_\_\_\_\_ Software Ver # \_\_\_\_\_ and Date \_\_\_\_\_  
 Analog Board #2 Serial # \_\_\_\_\_ Software Ver # \_\_\_\_\_ and Date \_\_\_\_\_

### Compressor Motor Starter / Drive Information

Manufacturer \_\_\_\_\_ Part # \_\_\_\_\_ Model # \_\_\_\_\_  
 Starter Type \_\_\_\_\_ Serial # \_\_\_\_\_  
 Input Voltage \_\_\_\_\_ Voltage Range \_\_\_\_\_ Phase \_\_\_\_\_ Hz \_\_\_\_\_ Current \_\_\_\_\_  
 Output Voltage \_\_\_\_\_ Phase \_\_\_\_\_ Hz \_\_\_\_\_ Max FLA \_\_\_\_\_ Max LRA \_\_\_\_\_ Min Load FLA \_\_\_\_\_ Job FLA \_\_\_\_\_  
 Logic Board Serial # \_\_\_\_\_ U33 Prog. Ver. \_\_\_\_\_ Date \_\_\_\_\_ P/N \_\_\_\_\_  
 U34 Prog. Ver. \_\_\_\_\_ Date \_\_\_\_\_ P/N \_\_\_\_\_  
 U45 Prog. Ver. \_\_\_\_\_ Date \_\_\_\_\_ P/N \_\_\_\_\_  
 Harmonic Filter Serial # \_\_\_\_\_ Prog. Ver. \_\_\_\_\_ Date \_\_\_\_\_ P/N \_\_\_\_\_  
 Frick Interface Serial # \_\_\_\_\_ Prog. Ver. \_\_\_\_\_ Date \_\_\_\_\_ P/N \_\_\_\_\_  
 CT Location Checked  CT Phase \_\_\_\_\_ CT Ratio \_\_\_\_\_ Transition Time \_\_\_\_\_ DBS Ver.# \_\_\_\_\_

### Oil Pump Information

Pump Mfg. \_\_\_\_\_ Model # \_\_\_\_\_ Serial # \_\_\_\_\_ Motor Mfg. \_\_\_\_\_ H.P. \_\_\_\_\_  
 Motor RPM \_\_\_\_\_ Service Factor \_\_\_\_\_ Volt \_\_\_\_\_ HZ \_\_\_\_\_ FLA \_\_\_\_\_ Design \_\_\_\_\_ Code \_\_\_\_\_ Starter Size \_\_\_\_\_

### Cooling Fan Information

Motor HP \_\_\_\_\_ RPM \_\_\_\_\_ Service Factor \_\_\_\_\_ Volt \_\_\_\_\_ Hz \_\_\_\_\_ FLA \_\_\_\_\_ Cooling Fans \_\_\_\_\_

### Special Options

\_\_\_\_\_  \_\_\_\_\_  \_\_\_\_\_  \_\_\_\_\_

### Prestart Checks

- |   |   |   |
|---|---|---|
| <input type="checkbox"/> Installation, Foundation   | <input type="checkbox"/> Compressor PHD Setup               | <input type="checkbox"/> Coolant Installed            |
| <input type="checkbox"/> Position of all valves   | <input type="checkbox"/> Motor PHD Setup                    | <input type="checkbox"/> 4-20 Coolant Loop Pump Setup |
| <input type="checkbox"/> Proper oil charge  | <input type="checkbox"/> Motor Winding RTD's Setup          | <input type="checkbox"/> Coolant Loop Temp Setup      |
| <input type="checkbox"/> All wiring connections   | <input type="checkbox"/> Motor Bearing RTD's Setup          | <input type="checkbox"/> Cooling Fan Motor I/O Setup  |
| <input type="checkbox"/> Starter Cleanliness  | <input type="checkbox"/> Motor Temperature Thermistor Setup | <input type="checkbox"/> Cooling Fan Rotation Checked |
| <input type="checkbox"/> All micro settings   | <input type="checkbox"/> 4-20 Motor Drive Signal Calibrated | <input type="checkbox"/> Oil pump motor rotation      |
| <input type="checkbox"/> 4-20 CT Channel 16 Setup   | <input type="checkbox"/> Cold alignment                     | <input type="checkbox"/> Motor rotation               |
| <input type="checkbox"/> 4-20 Output Calibration – Liquid Makeup Valve, Coolant Temp Valve, Economizer Makeup Valve |   |   |

### Configuration

Capacity	Channel	Direction	Package
Mode 1 _____	_____	_____	Compressor _____
Mode 2 _____	_____	_____	Pump _____
Mode 3 _____	_____	_____	Dual Pump _____
Mode 4 _____	_____	_____	Drive _____
VFD Hi & Low PI Control	_____	_____	Refrigerant _____ K-Factor _____
Miscellaneous	_____	_____	Filter _____
Sequencing _____	_____	_____	PowerPac _____
Condenser _____	_____	_____	
Screen Saver _____	_____	_____	

Page 2

Unit Serial # \_\_\_\_\_ Frick Order No: \_\_\_\_\_

Mode _____ Capacity Control Setpoints				Mode _____			
Setpoint _____		Regulation Safeties		Setpoint _____		Regulation Safeties	
High	Low	Load Inhibit	_____	High	Low	Load Inhibit	_____
Prop. Band	_____	_____	Force Unload _____	Prop. Band	_____	_____	Force Unload _____
Dead Band	_____	_____	Warning _____	Dead Band	_____	_____	Warning _____
Cycle Time	_____ Sec	_____ Sec	Warning Delay _____ Sec	Cycle Time	_____ Sec	_____ Sec	Warning Delay _____ Sec
VFD Prop Band	_____	_____	Shutdown _____	VFD Prop Band	_____	_____	Shutdown _____
VFD Integ. Time	_____ Sec	_____ Sec	Shutdown Delay _____ Sec	VFD Integ. Time	_____ Sec	_____ Sec	Shutdown Delay _____ Sec
Channel	_____			Channel	_____		
Auto Cycle	_____	_____	Low Suction _____	Auto Cycle	_____	_____	Low Suction _____
Start	_____	_____	Load Inhibit _____	Start	_____	_____	Load Inhibit _____
Start Delay	_____ Min	_____	Force Unload _____	Start Delay	_____ Min	_____	Force Unload _____
Stop	_____	_____	Warning _____	Stop	_____	_____	Warning _____
Stop Delay	_____ Min	_____	Warning Delay _____ Sec	Stop Delay	_____ Min	_____	Warning Delay _____ Sec
			Shutdown _____				Shutdown _____
			Shutdown Delay _____ Sec				Shutdown Delay _____ Sec

Compressor Safeties			
<b>High Discharge Temperature</b>		<b>High Suction Pressure</b>	
Load Inhibit	_____	Load Inhibit	_____ PSIG
Force Unload	_____	Force Unload	_____ PSIG
Warning	_____	Warning	_____ PSIG
Warning Delay	_____ Sec	Warning Delay	_____ Sec
Shutdown	_____	Shutdown	_____ PSIG
Shutdown Delay	_____ Sec	Shutdown Delay	_____ Sec
High Discharge Pressure	_____	Economizer	_____
Regulation Modes 1 & 3	_____ PSIG	On When Above	_____ %
Regulation Modes 2 & 4	_____ PSIG	Off When Below	_____ %
Load Inhibit	_____ PSIG	Override Discharge Pressure	_____
Force Unload	_____ PSIG	Port Value	_____
Warning	_____ PSIG	Pressure Input	_____
Warning Delay	_____ Sec	Fixed Pressure Setpoint	_____
Shutdown	_____ PSIG		
Shutdown Delay	_____ Sec		
Maximum Discharge Pressure	_____ PSIG	Balance Piston	_____
Highest Cap. To Permit Start	_____ %	On	_____ %
Start Period Before Cap. Increase	_____	Off	_____ %
Stopping Period For Cap. Unload	_____	Ignore Delay	_____ Min
Compressor Auto Mode Min. Cap.	_____ %	Fail Delay	_____ Min
Capacity Unload Assist.	_____ Rate _____ %	Oil Log	_____ Delay _____ Sec.
Separator Velocity Ref.	_____		
Compression Ratio	_____		
Liquid Slug Warning	_____	Main Oil Injection On When Discharge Temperature	_____
Liquid Slug Shutdown	_____	Is Above _____ °F for _____ Sec	

Package Safeties			
Low Compressor Oil Temperature	_____	Pull Down	_____
Warning	_____ Delay _____ Sec	Capacity Position	_____ %
Shutdown	_____ Delay _____ Sec	Amount of Time	_____ Sec
High Compressor Oil Temperature	_____	Pump Down	_____
Warning	_____ Delay _____ Sec	On When Suction Above	_____ PSIG Delay _____ Min
Shutdown	_____ Delay _____ Sec	DX Circuit	_____
Low Compressor Oil Pressure	_____	#1 Action	_____
Warning	_____ PSI Delay _____ Sec	Off When Below	_____ %
Shutdown	_____ PSI Delay _____ Sec	On When Above	_____ %
High Filter Pressure	_____	#2 Action	_____
Warning	_____ PSI Delay _____ Min	Off When Below	_____ %
Shutdown	_____ PSI Delay _____ Min	On When Above	_____ %
Main Oil Injection	_____	Liquid Injection	_____
Shutdown	_____ PSI Delay _____ Sec	On When Above	_____ Delay _____ Sec
Oil Heater Off Above	_____	Dual Port Transition	_____
High Level Shutdown Delay	_____ Sec		
Low Oil Level Delay	_____ Sec	Hot Gas Bypass	_____ %
Oil Pump Lube Time Before Starting	_____ Sec	Power Assist	_____ Sec
Dual Pump Transition Time	_____ Sec		



Page 3

Unit Serial # \_\_\_\_\_ Frick Order No: \_\_\_\_\_

**Compressor Motor Setpoints and Information**

<b>Motor Name Plate</b>		<b>VFD</b>	Manufacturer _____
Motor Amps _____		Maximum Drive Output ____ %	Frame Size _____
Volts _____		Minimum Drive Output ____ %	H.P. _____
Service Factor _____		Remote Control _____	RPM _____
Horsepower _____		Rate Of Increase _____ % Delay ____ Sec	Serial # _____
CT Factor _____		Rate Of Decrease _____ % Delay ____ Sec	Service Factor _____
Recycle Delay _____ Min		Capacity Control _____	Voltage _____
High Motor Amps _____		When Slide Valve Reaches _____ %	Hz _____
Load Inhibit _____		Drive Speed Reaches _____ %	Design _____
Force Unload _____	Variable Speed Min. Slide Valve Position _____ %		Code _____
Warning _____ Delay ____ Sec		Skip Frequency Bands	Bearing Type _____
Shutdown _____ Delay ____ Sec		Bottom _____ Top _____	Motor Coupling _____
		_____	
Low Motor Amps _____		_____	
Shut Down _____ Delay ____ Sec		_____	
Confirmed Running Motor Amps _____		_____	
Starting Motor Amps Ignore Period _____ Sec		_____	

**Vyper Coolant Setpoints**

Vyper Standby Time \_\_\_\_\_ Vyper Coolant Low Temp. Alarm \_\_\_\_\_ Delay \_\_\_\_\_ Shutdown \_\_\_\_\_ Delay \_\_\_\_\_  
High Temp. Alarm \_\_\_\_\_ Delay \_\_\_\_\_ Shutdown \_\_\_\_\_ Delay \_\_\_\_\_

**PHD Monitoring Setpoints**

**Condenser Control**

<b>Compressor Bearing</b> _____		<b>Condenser Control Setpoint</b> _____	
<b>Suction End</b>	<b>Delay</b>	<b>Discharge End</b>	<b>Delay</b>
High Warning _____ gF _____ Sec		High Warning _____ gF _____ Sec	
High Shutdown _____ gF _____ Sec		High Shutdown _____ gF _____ Sec	
Motor Bearing _____			
Shaft Side	Delay	Opposite Shaft Side	Delay
High Warning _____ F _____ Sec		High Warning _____ F _____ Sec	
High Shutdown _____ F _____ Sec		High Shutdown _____ F _____ Sec	
Motor Stator _____			
Stator 1	Delay	Stator 2	Delay
High Warning _____ F _____ Sec		High Warning _____ F _____ Sec	
High Shutdown _____ F _____ Sec		High Shutdown _____ F _____ Sec	
Stator 3	Delay		
High Warning _____ F _____ Sec			
High Shutdown _____ F _____ Sec			

<b>Digital Controls</b>	<b>Step Order</b>
Module A _____	_____
Module B _____	_____
Module C _____	_____
Module D _____	_____
Step Up Dead Band _____ PSI	
Step Up Delay _____ Sec	
Step Down Dead Band _____ PSI	
Step Down Delay _____ Sec	
High Pressure Override _____ PSI	
High Pressure Override Delay _____ Sec	
Analog Controls	Analog Output A _____
	Analog Output B _____
	Proportional Band _____ PSI
	Integration Time _____ Sec
	High Limit _____ PSI
	Low Limit _____ Sec

**Miscellaneous**

Remote Capacity Deadband \_\_\_\_\_ % Max Slide Valve Timer \_\_\_\_\_ 1/10 Sec  
High Compressor Oil Pressure \_\_\_\_\_ PSI Max Discharge Pressure \_\_\_\_\_ PSI  
Shutdown \_\_\_\_\_ PSI Delay \_\_\_\_ Sec Max Discharge and Oil Temp \_\_\_\_\_ °F

**P&ID Setpoints**

Name	_____	_____	_____	_____
Control	_____	_____	_____	_____
Action	_____	_____	_____	_____
Control Point	_____	_____	_____	_____
Device Source	_____	_____	_____	_____
Device Channel	_____	_____	_____	_____
Setpoint	_____	_____	_____	_____
Dead Band	_____	_____	_____	_____
Prop. Band	_____	_____	_____	_____
Integral Gain	_____	_____	_____	_____

Page 4

Unit Serial # \_\_\_\_\_ Frick Order No: \_\_\_\_\_

**Communications**

**Compressor ID** \_\_\_\_\_

**Comm 1**

Baud Rate \_\_\_\_\_  
Data Bits \_\_\_\_\_  
Stop Bits \_\_\_\_\_  
Parity \_\_\_\_\_  
RS 485 Connection \_\_\_\_\_  
Protocol \_\_\_\_\_

**Comm 2**

Baud Rate \_\_\_\_\_  
Data Bits \_\_\_\_\_  
Stop Bits \_\_\_\_\_  
Parity \_\_\_\_\_  
RS 485 Connection \_\_\_\_\_  
Protocol \_\_\_\_\_

**Comm 3**

Baud Rate \_\_\_\_\_  
Data Bits \_\_\_\_\_  
Stop Bits \_\_\_\_\_  
Parity \_\_\_\_\_  
RS 485 Connection \_\_\_\_\_  
Protocol \_\_\_\_\_

Use Map File \_\_\_\_\_

**Ethernet**

**IP Data**

Address Type \_\_\_\_\_  
IP Address \_\_\_\_\_  
Gateway Address \_\_\_\_\_  
Subnet Mask \_\_\_\_\_  
Web Server Port \_\_\_\_\_

**Naming Data**

Host Name \_\_\_\_\_  
Work Group \_\_\_\_\_  
Comments \_\_\_\_\_

**Protocols**

ModBus TCP \_\_\_\_\_  
Ethernet I/P \_\_\_\_\_  
Profinet \_\_\_\_\_

**Drive Train Alignment**

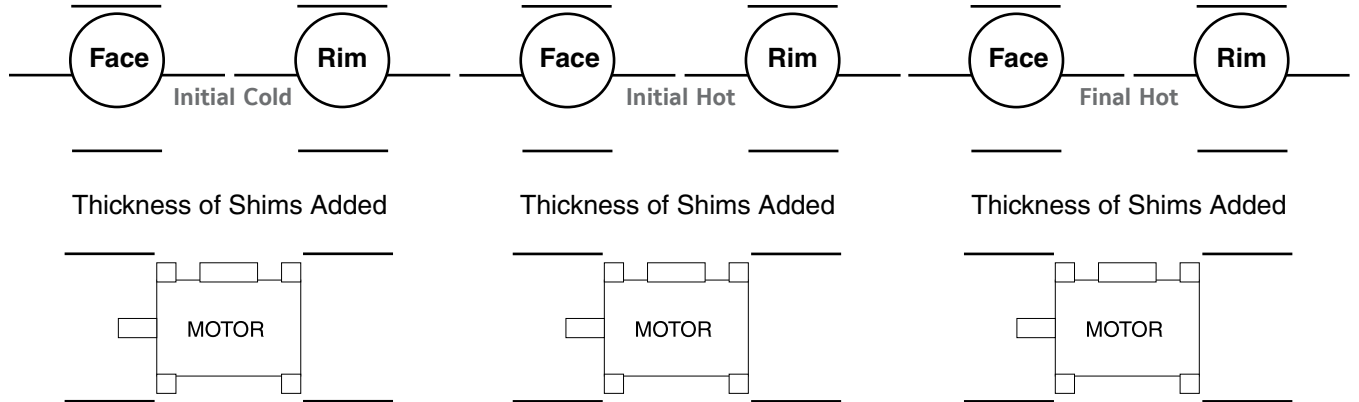

Compressor Operating Log Sheet				Starter Operating Log Sheet			
Date				Average Current			
Time				Current Phase A			
Hour Meter Reading				Current Phase B			
Equip. Room Temp.				Current Phase C			
Suction Pressure				Full Load Amps			
Suction Temperature				Output Frequency			
Suction Superheat				Output Voltage			
Discharge Pressure				DC Bus Voltage			
Discharge Temperature				Input Power kW			
Corresponding Temperature				Actual Speed			
Oil Pressure				Speed Command			
Oil Temperature				Ambient Temp F.			
Oil Filter Pressure Drop				Convert Heatsink Temp. F.			
Separator Temperature				Baseplate Temp. F.			
Slide Valve Position				VSD Operating Mode			
Volume Ratio (VI)				Harmonic Filter Present			
Motor Amps / FLA %				Harmonic Filter Mode			
Capacity Control Setpoint				Water Pump Energized			
Oil Level				Precharge Relay Energized			
Oil Added				Trigger SCR's Energized			
Seal Leakage (Drops/Min.)				DC Inverter Link Current			
Evaporator. EWT F.				Motor Winding Temp. F.			
Evaporator LWT F.				Humidistat % RH			
Condenser EWT F.				Vyper Coolant Temp. F.			
Condenser LWT F.				Total kWh			

### VIBRATION DATA SHEET

Date: \_\_\_\_\_  
End User: \_\_\_\_\_  
Address: \_\_\_\_\_

Sales Order Number: \_\_\_\_\_  
Installing Contractor: \_\_\_\_\_  
Service Technician: \_\_\_\_\_

Equipment ID (As in Microlog): \_\_\_\_\_  
Compressor Serial Number: \_\_\_\_\_  
Unit Serial Number: \_\_\_\_\_  
National Board Number: \_\_\_\_\_  
Running Hours: \_\_\_\_\_  
Manufacturer and Size of Coupling: \_\_\_\_\_  
Motor Manufacturer: RAM \_\_\_\_\_  
Motor Serial Number: \_\_\_\_\_  
RPM: \_\_\_\_\_ Frame Size: \_\_\_\_\_ H.P. \_\_\_\_\_  
Refrigerant: \_\_\_\_\_  
Ambient Room Temperature: \_\_\_\_\_ °F  
Operating Conditions: \_\_\_\_\_

**Final Hot Alignment**



**Total Thickness of Shims Added**

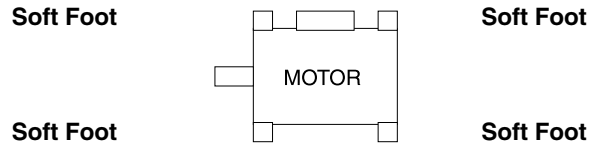

SUCTION		DISCHARGE		OIL		SEPARATOR		Slide Valve Position		%
Press	#	Press	#	Press	#	Temp	°F	V.I. Ratio		
Temp	°F	Temp	°F	Temp	°F			F.L.A.		%

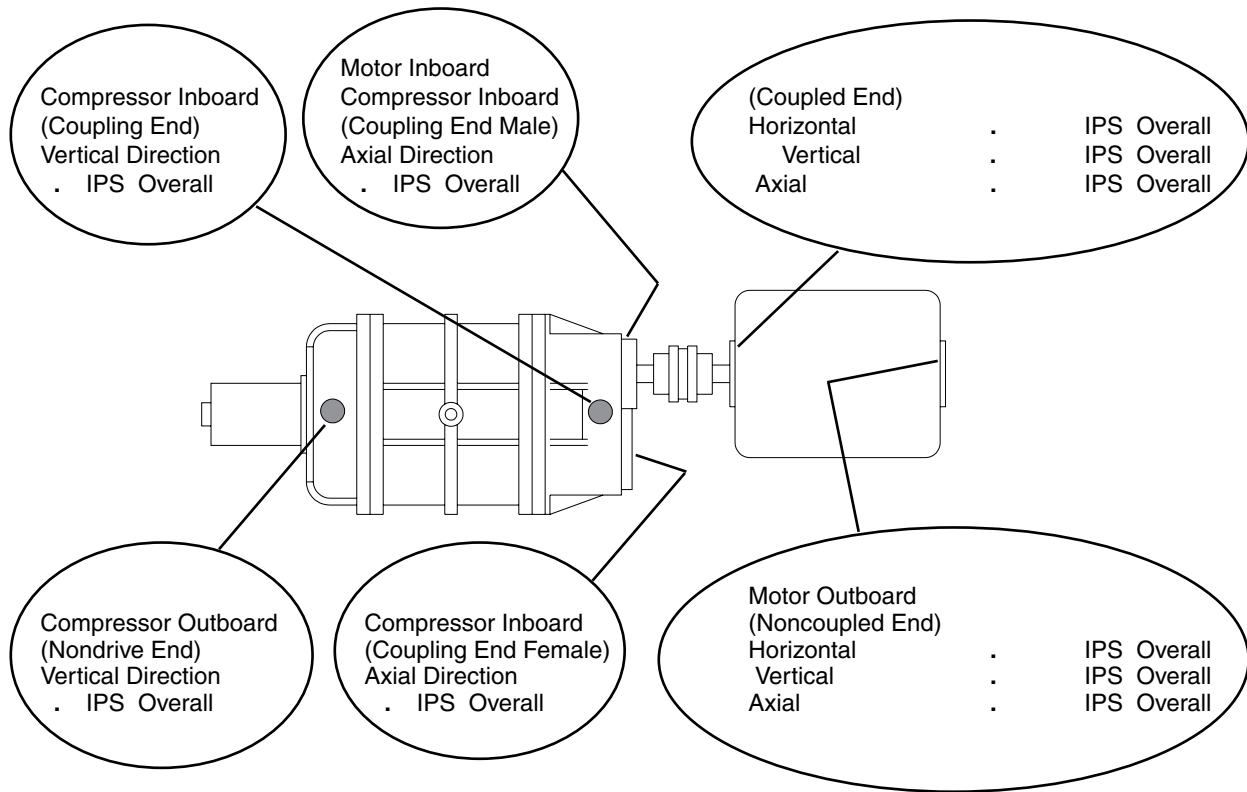



# Q-NET™ network technology...

Connect Your PC  
with QUANTUM™LX!

*Take full advantage of Q-NET™  
technology with all Frick products!*



## ***System integration is what we do...***

- Q-NET™... supports open-protocols for SCADA systems (i.e. Allen-Bradley® DF1, Modbus RTU, Modbus ASCII, and Industrial Ethernet Protocols)
- Q-NET™... connects instantly for local or remote access; no software required
- Q-NET™... can be applied to both new and existing systems
- Q-NET™ means precise control 24 hours a day, seven days a week
- Q-NET™ distributed architecture mean faster, easier, economical installations
- Q-NET™ delivers increased operating efficiency and lowers energy costs

Available on Frick screw compressors, condensers, evaporators, AcuAir® hygienic air handlers, and refrigerant vessels.

Form 070-200 IOM (2009-01)  
Supersedes: S70-200 IOM (2005-09)  
Subject to change without notice  
Published in USA · GUI 1C

© 2009 Johnson Controls Inc. - ALL RIGHTS RESERVED



JOHNSON CONTROLS  
100 CV Avenue · P.O. Box 997  
Waynesboro, PA 17268-0997 USA  
Phone: 717-762-2121 · FAX: 717-762-8624  
[www.johnsoncontrols.com](http://www.johnsoncontrols.com)