

4195KA, KB, KC, and KS Series Gauge Pressure Controllers

Contents

1. Introduction		
Scope of Manual	1-3	
Description	1-4	
Specifications	1-4	
Educational Services	1-4	
2. Installation		
Controller Mounting Orientation	2-1	
Pipestand Mounting	2-1	
Panel Mounting	2-1	
Wall Mounting	2-1	
Actuator Mounting	2-1	
Pressure Connections	2-2	
Process Pressure Connection	2-3	
Supply Pressure Connection	2-4	
Remote Set Point (suffix letter M)		
Pressure Connection	2-4	
External Feedback Pressure Connection (4195KB Series Controllers Only)	2-4	
Vent	2-5	
3. 4195KA Series Proportional-Only Controllers		
Adjustments for 4195KA Series Controllers	3-1	
Manual Set Point Adjustment	3-1	
Remote Set Point (suffix letter M)		
Adjustment	3-1	
Proportional Band Adjustment (PB ADJ)	3-1	
Changing Controller Action	3-2	
Switching The Auto/Manual Station (suffix letter E)	3-2	
Prestartup Checks for 4195KA Series Controllers	3-2	
Startup for 4195KA Series Controllers	3-3	
Calibration of 4195KA Series Controllers	3-4	
General Calibration Instructions	3-4	
Process Indicator Zero and Span Calibration	3-4	
Remote Set Point (suffix letter M)		
Zero and Span Calibration	3-6	
Flapper Alignment	3-6	
Principle of Operation for 4195KA Series Controllers	3-7	
Overall Operation	3-7	
Remote Set Point (suffix letter M)		
Operation	3-8	
Auto/Manual Station (suffix letter E)		
Operation	3-8	
4. 4195KB Series Proportional-Plus-Reset Controllers and 4195KC Series Proportional-Plus-Reset-Plus-Rate Controllers		
Adjustments for 4195KB and KC Series Controllers	4-1	
Manual Set Point Adjustment	4-1	
Remote Set Point (suffix letter M)		
Adjustment	4-1	
Proportional Band Adjustment (PB ADJ)	4-2	
Changing Controller Action	4-2	
Reset Adjustment	4-2	
Rate Adjustment	4-2	
Anti-Reset Windup (suffix letter F)		
Adjustment	4-2	
Switching the Auto/Manual Station (suffix letter E)	4-3	
Prestartup Checks for 4195KB and KC Series Controllers	4-3	
Startup for 4195KB and KC Series Controllers	4-4	
Calibration of 4195KB and KC Series Controllers	4-4	
General Calibration Instructions	4-5	
Process Indicator Zero and Span Calibration	4-5	
Remote Set Point (suffix letter M)		
Zero and Span Calibration	4-5	
Flapper Alignment	4-7	
Anti-Reset Windup (suffix letter F)		
Differential Relief Valve Calibration	4-9	
Principle of Operation for 4195KB and KC Series Controllers	4-10	
Overall Operation	4-10	
Anti-Reset Windup (suffix letter F)		
Operation	4-13	
Remote Set Point (suffix letter M)		
Operation	4-13	
Auto/Manual Station (suffix letter E)		
Operation	4-13	
External Feedback Operation	4-13	



4195KA, KB, KC, and KS Controllers

Contents (continued)

- 5. 4195KS Series Differential Gap Controllers
 - Operating Information 5-1
 - Adjustments for 4195KS Series Differential Gap Controllers 5-1
 - Manual Set Point 5-1
 - Remote Set Point (Option M) 5-1
 - Proportional Band (Differential Gap) 5-1
 - Changing Controller Action 5-1
 - Auto/Manual Switching (Option E) 5-1
 - Prestartup Checks 5-2
 - Startup 5-2
 - Calibration 5-3
 - Process Zero and Span Adjustment 5-3
 - Remote Set Point Zero and Span (Option M) 5-4
 - Setting Switching Points 5-5
 - Direct-Acting Controllers 5-5
 - Reverse-Acting Controllers 5-5
 - Principle of Operation 5-7
 - Overall Operation 5-7
 - Remote Set Point (Option M) 5-8
 - Auto/Manual Option 5-8
- 6. Maintenance
 - Inspection and Maintenance 6-1
 - Troubleshooting 6-1
 - Replacing Common Controller Parts 6-1
 - Replacing the Process Pressure Scale ... 6-5
 - Replacing the Relay 6-6
 - Replacing the Case and Cover 6-6
 - Replacing the Gauges 6-6
 - Replacing the Supply Gauge, Proportional, Reset, Reset Valve and Positive Tubing Feedback Assemblies 6-7
 - Replacing the Proportional Band Adjustment Knob, Nozzle Assembly, and Set Point Beam Assembly 6-7
 - Replacing the Flapper Assembly and Flapper Flexure Pivot Assembly 6-11
 - Replacing the Proportional or Reset Bellows 6-15
 - Replacing the Reset Restriction Valve (4195KB Series) 6-17
 - Replacing the Rate/Reset Valve Assembly (4195KC Series) 6-18
 - Replacing the Anti-Reset Windup (suffix letter F) Differential Relief Valve 6-19
 - Replacing the Anti-Reset Windup (suffix letter F) Relief Valve Tubing Assembly 6-19
 - Bourdon Tube Controller Maintenance and Calibration 6-20
 - Replacing the Bourdon Tube 6-20
 - Replacing Bourdon Tube Controller Links 6-20
 - Replacing Link 1 6-20
 - Replacing Link 2 6-21
 - Replacing Link 3 6-22
 - Replacing Link 4 6-22

- Bourdon Tube Travel Stop Installation and Adjustment 6-23
- Bourdon Tube Controller Calibration: Zero and Span Adjustment 6-24
- Capsular Element Controller Maintenance and Calibration 6-27
 - Replacing the Capsular Element Assembly 6-27
 - Replacing Capsular Element Parts 6-27
 - Replacing the Long Pivot Assembly ... 6-27
 - Replacing the Short Pivot Assembly ... 6-28
 - Replacing the Process Drive Flexure ... 6-28
 - Replacing the Process Tubing 6-29
- Replacing Capsular Element Controller Links 6-29
 - Replacing Link 1 6-30
 - Replacing Link 2 6-30
 - Replacing Link 3 6-30
 - Replacing Link 4 6-31
 - Replacing Link 5 6-31
- Capsular Element Controller Maintenance Calibration 6-32
 - Precalibration Procedure 6-32
 - Aligning the Drive Bracket Assembly .. 6-32
 - Setting the Travel Stops 6-32
 - Aligning the Linkage 6-33
- Capsular Element Controller Zero and Span Adjustment 6-34
- Remote Set Point (suffix letter M) Maintenance 6-36
 - Replacing the Remote Set Point Assembly 6-36
- Replacing Remote Set Point Assembly Parts 6-36
 - Replacing Pivot Assembly A (key 114) . 6-36
 - Replacing Pivot Assembly B (key 115) . 6-37
 - Replacing the Drive Flexure 6-37
 - Replacing the Remote Set Point Tubing 6-38
 - Replacing Link A 6-38
 - Replacing Link B 6-38
- Remote Set Point (suffix letter M) Maintenance Calibration 6-38
 - Precalibration Procedure 6-38
 - Aligning the Flexures 6-39
 - Setting the Travel Stops 6-39
 - Aligning the Linkage 6-39
- Remote Set Point Zero and Span Adjustment 6-40
- Remote Set Point Linearity Adjustment .. 6-41
- Auto/Manual Station (suffix letter E) Maintenance 6-41
 - Replacing the Auto/Manual Station 6-41



W5663-1 / IL

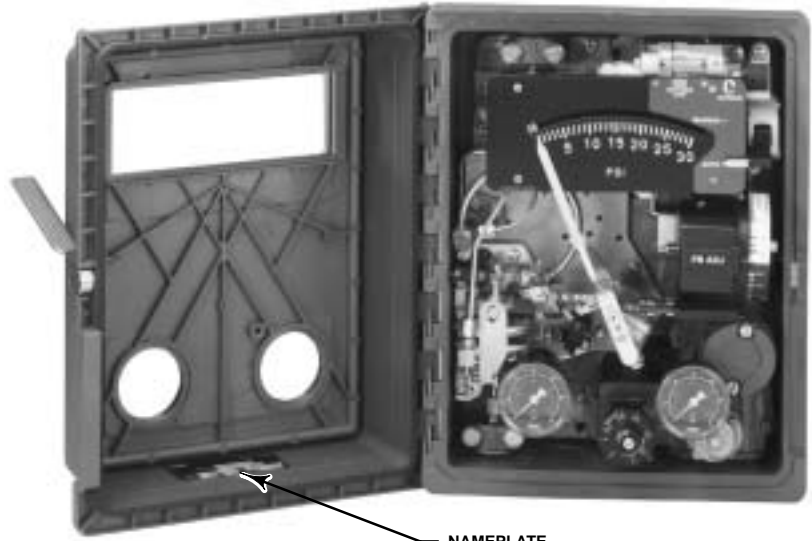

W6831 / IL

Figure 1-1. 4195K Series Gauge Pressure Controllers

Contents (continued)

Replacing the Switch Body Assembly,
Lever O-Ring, Switch Body O-Ring,
and Tubing Assembly 6-42

Replacing the Loader Range Spring,
Diaphragm Assembly, Ball Seat,
Tubing, and Ball 6-43

Replacing the Loader Valve Plug and
Valve Plug Spring 6-44

7. Parts

Parts Ordering 7-1

Parts Kits 7-1

Parts List 7-1

Abbreviations Used In The Parts List 7-1

Controller Common Parts 7-1

Process and Set Point Indicator
Assembly 7-11

Indicator Assembly 7-14

Capsular Element Assembly 7-14

Remote Set Point Assembly
(suffix letter M) 7-16

Auto/Manual Station (suffix letter E) 7-17

Controller Mounting Parts 7-19

Pipestand Mounting 7-19

Pipestand Mounting with Regulator 7-19

Panel Mounting 7-19

Wall Mounting 7-19

Controller Mounting Parts for Actuator
with Casing-Mounted Controller 7-19

Controller Mounting Parts for Actuator
with Yoke-Mounted Controller 7-19

Regulator Mounting Parts 7-19

Regulator Mounting Parts for
Casing-Mounted Regulator 7-19

Regulator Mounting Parts for
Yoke-Mounted Regulator (Mounting
Bracket Not Required) 7-19

Regulator Mounting Parts for
Yoke-Mounted Regulator
(With Mounting Bracket) 7-19

Fittings 7-20

**Section 1
Introduction**

Scope of Manual

This instruction manual provides installation, operating, calibration, maintenance, and parts ordering information for 4195KA, KB, KC, and KS Series gauge pressure indicating controllers.

4195KA, KB, KC, and KS Controllers

Portions of this manual apply only to specific 4195K Series controller configurations. These configurations are indicated by letter suffixes in the type number that correspond to the mode and option designated in table 1-2.

The specific controller type number (with letter suffixes) is located on the nameplate shown in figure 1-1. Refer to table 1-2 for the definition of each 4195K Series type number.

Do not install, operate, or maintain this product without first ● being fully trained and qualified in valve, actuator, and accessory installation, operation, and maintenance, and ● carefully reading and understanding the contents of this manual. If you have any questions about these instructions, contact your Emerson Process Management™ sales office before proceeding.

Description

The controllers described in this manual provide gauge pressure control with the options as shown in table 1-2.

- 4195KA Series: Proportional-only control
- 4195KB Series: Proportional-plus-reset control
- 4195KC Series:
Proportional-plus-reset-plus-rate control
- 4195KS Series: Differential gap control

These controllers show process pressure and set point on an easy-to-read process scale. The controller output is a pneumatic signal that operates a final control element.

Specifications

Specifications for the 4195KA, KB, KC, and KS Series controllers are listed in table 1-1.

Educational Services

For information on available courses for the 4195KA, 4195KB, 4195KC, and 4195KS Series gauge pressure indicating controllers, as well as a variety of other products, contact:

Emerson Process Management
Educational Services, Registration
P.O. Box 190; 301 S. 1st Ave.
Marshalltown, IA 50158-2823
Phone: 800-338-8158 or
Phone: 641-754-3771
FAX: 641-754-3431
e-mail: education@emersonprocess.com

Note

Neither Emerson, Emerson Process Management, nor any of their affiliated entities assumes responsibility for the selection, use, and maintenance of any product. Responsibility for the selection, use, and maintenance of any product remains with the purchaser and end-user.

Table 1-1. Specifications

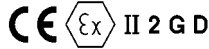
<p>Available Configurations</p> <p>See table 1-2</p> <p>Input Signal (Process Sensor Range⁽¹⁾)</p> <p>Lower and Upper Range Limits: See tables 1-3 and 1-4</p> <p>Maximum Allowable Operating Limits: See tables 1-3 and 1-4</p> <p>Output Signal⁽¹⁾</p> <p>Proportional-Only, Proportional-Plus-Reset, or Proportional-Plus-Reset-Plus-Rate Range: 0.2 to 1.0 bar or 0.4 to 2.0 bar (3 to 15 psig or 6 to 30 psig)</p> <p>Differential Gap Range: 0 and 1.4 bar (0 and 20 psig) or 0 and 2.4 bar (0 and 35 psig)</p> <p>Action: Field-reversible between direct (increasing sensed process pressure increases output pressure) or reverse (increasing sensed process pressure decreases output pressure).</p> <p>Process Scale</p> <p>Standard scale is matched to the range of the sensing element, with the exception of receiver controllers. Optional⁽²⁾ scales are available.</p> <p>Process Connections</p> <p>Standard: 1/4 NPT, internal, stainless steel (all input ranges)</p> <p>Optional: 1/2 NPT, see table 1-5</p> <p>Supply and Output Connections</p> <p>1/4 NPT, internal</p> <p>Supply Pressure Requirements⁽³⁾</p> <p>See table 1-6</p> <p>Supply Pressure Medium</p> <p>Air or natural gas⁽⁴⁾</p> <p>Remote Set Point Pressure Ranges</p> <p>0.2 to 1.0 bar or 0.4 to 2.0 bar (3 to 15 psig or 6 to 30 psig)</p>	<p>Controller Adjustments</p> <p>Proportional Band⁽¹⁾: 5 to 500% of process input span</p> <p>Reset⁽¹⁾: Adjustable from 0.01 to more than 74 minutes per repeat (from 100 to less than 0.0135 repeats per minute)</p> <p>Rate⁽¹⁾: Adjustable from 0 to 20 minutes</p> <p>Differential Gap⁽¹⁾ Controllers: Adjustable from 5 to 100% of process scale range</p> <p>Set Point: Adjustable from 0 to 100% of the scale span</p> <p>Controller Performance</p> <p>Repeatability⁽¹⁾: 0.4% of output span</p> <p>Dead Band⁽¹⁾: Less than 0.4% of process scale span</p> <p>Typical Frequency Response: 1.5 hertz and 90 degree phase shift with 3.05 m (10 feet) of 6.4 mm (1/4-inch) tubing and 1639 cm³ (100 cubic inch) volume</p> <p>Steady-State Air Consumption^(1,5,6)</p> <p><i>0.2 to 1.0 Bar (3 to 15 Psig) Output:</i> 0.1 normal m³/hr (3.5 scfh)</p> <p><i>0.4 to 2.0 Bar (6 to 30 Psig) Output:</i> 0.14 normal m³/hr (5.0 scfh)</p> <p>Delivery Capacity⁽⁵⁾</p> <p><i>0.2 to 1.0 Bar (3 to 15 Psig) Output:</i> 5.9 normal m³/hr (240 scfh)</p> <p><i>0.4 to 2.0 Bar (6 to 30 Psig) Output:</i> 10.4 normal m³/hr (350 scfh)</p> <p>Operative Ambient Temperature Limits^(1,3,7)</p> <p>-40 to 71°C (-40 to 160°F)</p> <p>Exhaust Capacity⁽⁵⁾</p> <p><i>0.2 to 1.0 Bar (3 to 15 Psig) Output:</i> 4.6 normal m³/hr (186 scfh)</p> <p><i>0.4 to 2.0 Bar (6 to 30 Psig) Output:</i> 7.0 normal m³/hr (295 scfh)</p> <p>Hazardous Area Classification</p> <p>Complies with the requirements of ATEX Group II Category 2 Gas and Dust</p> <p></p>
--	--

continued

4195KA, KB, KC, and KS Controllers

Table 1-1. Specifications (continued)

<p>Housing</p> <p>Designed to NEMA 3 (Weatherproof) and IEC 529 IP54 Specifications</p> <p>Mounting</p> <p>Controller can be mounted on actuator, panel, wall, or pipestand.</p> <p>Approximate Weight</p> <p>4.5 kg (10 pounds)</p>	<p>Declaration of SEP</p> <p>Fisher Controls International LLC declares this product to be in compliance with Article 3 paragraph 3 of the Pressure Equipment Directive (PED) 97 / 23 / EC. It was designed and manufactured in accordance with Sound Engineering Practice (SEP) and cannot bear the CE marking related to PED compliance.</p> <p>However, the product <i>may</i> bear the CE marking to indicate compliance with <i>other</i> applicable EC Directives.</p>
---	---

1. These terms are defined in ISA Standard S51.1.
2. Consult your Emerson sales office for additional information.
3. The pressure/temperature limits in this document and any applicable standard or code limitation should not be exceeded.
4. This product can be used with natural gas. Natural gas should not contain more than 20 ppm of H₂S.
5. Normal m³/hr—Normal cubic meters per hour (0°C and 1.01325 bar, absolute). Scfh—Standard cubic feet per hour (60°F and 14.7 psia).
6. Without auto/manual station. With auto/manual station, air consumption is 0.28 normal m³/hr (10.0 Scfh) for either output range.
7. Also use these temperatures for transportation and storage limits.

Table 1-2. Available Configurations for 4195KA, 4195KB, 4195KC, and 4195KS Series Controllers

SERIES	TYPE NUMBER ⁽¹⁾	MODES				OPTIONS		
		Proportional-Only (One-Mode Controllers)	Proportional-Plus-Reset (Two-Mode Controllers)	Proportional-Plus-Reset-Plus-Rate (Three-Mode Controllers)	Differential Gap Controller	Internal Auto/Manual Station E	Anti-Reset Windup F	Remote Setpoint M
4195KA	4195KA	X	---	---	---	---	---	---
	4195KAE	X	---	---	---	X	---	---
	4195KAM	X	---	---	---	---	---	X
	4195KAME	X	---	---	---	X	---	X
4195KB	4195KB	---	X	---	---	---	---	---
	4195KBE	---	X	---	---	X	---	---
	4195KBF	---	X	---	---	---	X	---
	4195KBFE	---	X	---	---	X	X	---
	4195KBM	---	X	---	---	---	---	X
	4195KBME	---	X	---	---	X	---	X
	4195KBFM	---	X	---	---	---	X	X
	4195KBFME	---	X	---	---	X	X	X
4195KC	4195KC	---	---	X	---	---	---	---
	4195KCE	---	---	X	---	X	---	---
	4195KCF	---	---	X	---	---	X	---
	4195KCFE	---	---	X	---	X	X	---
	4195KCM	---	---	X	---	---	---	X
	4195KCME	---	---	X	---	X	---	X
	4195KCFM	---	---	X	---	---	X	X
	4195KCFME	---	---	X	---	X	X	X
4195KS	4195KS	---	---	---	X	---	---	---
	4195KSE	---	---	---	X	X	---	---
	4195KSM	---	---	---	X	---	---	X
	4195KSME	---	---	---	X	X	---	X

1. Reverse-acting constructions are designated by the suffix letter R added to the type number.

Instruction Manual

Form 5207
April 2007

4195KA, KB, KC, and KS Controllers

Table 1-3. Process Sensor (Capsular Element) Pressure Ratings

CAPSULE MATERIAL	CAPSULAR STANDARD RANGES			SPAN ⁽¹⁾		OPERATING RANGE		OPERATING LIMIT ⁽²⁾
				Min	Max	Min	Max	
N09902	Metric units	Positive pressure	0 to 150 mbar	100 mbar	160 mbar	-350 mbar	350 mbar	510 mbar
			0 to 400 mbar	350 mbar	700 mbar	-1 bar	1 bar	1.5 bar
			0 to 0.6 bar	0.35 bar	0.7 bar	-1 bar	1 bar	1.5 bar
			0.2 to 1 bar	0.4 bar	0.8 bar	-1 bar	1.4 bar	2 bar
			0 to 1 bar	0.5 bar	1 bar	-1 bar	1.4 bar	2 bar
			0 to 1.4 bar	0.7 bar	1.4 bar	-1 bar	1.7 bar	2.5 bar
		0 to 1.6 bar	1 bar	2 bar	-1 bar	2.4 bar	3.5 bar	
		0.4 to 2 bar	0.8 bar	1.6 bar	-1 bar	2 bar	3 bar	
		0 to 2 bar	1 bar	2 bar	-1 bar	2.4 bar	3.5 bar	
		Vacuum	-150 to 0 mbar	85 mbar	170 mbar	-350 mbar	350 mbar	510 mbar
			-340 to 0 mbar	170 mbar	340 mbar	-480 mbar	480 mbar	724 mbar
			-400 to 0 mbar	350 mbar	700 mbar	-1 bar	1 bar	1.5 bar
	-0.6 to 0 bar		0.35 bar	0.7 bar	-1 bar	1 bar	1.5 bar	
	-1 to 0 bar		0.5 bar	1 bar	-1 bar	1.4 bar	2 bar	
	Compound		-50 to 100 mbar	100 mbar	160 mbar	-350 mbar	350 mbar	510 mbar
		-175 to 175 mbar	175 mbar	350 mbar	-480 mbar	480 mbar	724 mbar	
-150 to 250 mbar		350 mbar	700 mbar	-1 bar	1 bar	1.5 bar		
-0.2 to 0.4 bar		0.35 bar	0.7 bar	-1 bar	1 bar	1.5 bar		
-0.4 to 0.6 bar		0.5 bar	1 bar	-1 bar	1.4 bar	2 bar		
-0.6 to 0.8 bar		0.7 bar	1.4 bar	-1 bar	1.7 bar	2.5 bar		
U.S. units	Positive pressure	0 to 60 inch wc	40 inch wc	60 inch wc	-10 inch Hg	5 psig	7.5 psig	
		0 to 5 psig	2.5 psig	5 psig	-14 inch Hg	7 psig	10.5 psig	
		0 to 10 psig	5 psig	10 psig	-30 inch Hg	15 psig	22.5 psig	
		3 to 15 psig	6 psig	12 psig	-30 inch Hg	20 psig	30 psig	
		0 to 15 psig	7.5 psig	15 psig	-30 inch Hg	20 psig	30 psig	
		0 to 20 psig	10 psig	20 psig	-30 inch Hg	25 psig	37.5 psig	
	6 to 30 psig	12 psig	24 psig	-30 inch Hg	30 psig	45 psig		
	0 to 30 psig	15 psig	30 psig	-30 inch Hg	35 psig	52.5 psig		
	Vacuum	-5 to 0 inch Hg	2.5 inch Hg	5 inch Hg	-10 inch Hg	5 psig	7.5 psig	
		-10 to 0 inch Hg	5 inch Hg	10 inch Hg	-14 inch Hg	7 psig	10.5 psig	
		-20 to 0 inch Hg	10 inch Hg	20 inch Hg	-30 inch Hg	15 psig	22.5 psig	
		-30 to 0 inch Hg	15 inch Hg	30 inch Hg	-30 inch Hg	20 psig	30 psig	
Compound		-30 to 30 inch wc	40 inch wc	60 inch wc	-10 inch Hg	5 psig	7.5 psig	
		-5 inch Hg to 2.5 psig	2.5 psig	5 psig	-14 inch Hg	7 psig	10.5 psig	
	-10 inch Hg to 5 psig	5 psig	10 psig	-30 inch Hg	15 psig	22.5 psig		
	-15 inch Hg to 7.5 psig	7.5 psig	15 psig	-30 inch Hg	20 psig	30 psig		
	-20 inch Hg to 10 psig	10 psig	20 psig	-30 inch Hg	25 psig	37.5 psig		
	-30 inch Hg to 15 psig	15 psig	30 psig	-30 inch Hg	35 psig	52.5 psig		

1. Minimum or maximum span, or any span in between, may be positioned anywhere within the operating range. For example, if a 0 to 350 mbar (0 to 5 psig) sensing element is used and the minimum span of 1.75 mbar (2.5 psig) is set, the process indication can be calibrated to a range of -340 mbar to -203 mbar (-10 inch Hg to -6 inch Hg), 0 to 172 mbar (0 to 2.5 psig), 172 to 345 mbar (2.5 to 5 psig), 305 to 480 mbar (4.5 to 7 psig), or any value between minimum and maximum values of operating range.

2. Capsules with the travel stops set may be pressured to this value without permanent zero shift.

4195KA, KB, KC, and KS Controllers

Table 1-4. Process Sensor (Bourdon Tube) Pressure Ratings and Materials

BOURDON TUBES		SPAN ⁽¹⁾		OPERATING RANGE ⁽²⁾		OPERATING LIMITS ⁽⁴⁾	STANDARD MATERIAL
		Minimum	Maximum	Minimum	Maximum ⁽³⁾		
Bar							
Metric units	0 to 1.6	1	2	-1	3	3.3	S31600 (316 SST)
	0 to 2.5	2	4	-1	6	6.6	
	0 to 4	2	4	-1	6	6.6	
	0 to 6	3.5	7	-1	10	11	
	0 to 10	7	14	-1	20	22	
	0 to 16	10	20	-1	30	33	
	0 to 25	20	40	0	60	66	
	0 to 40	20	40	0	60	66	
	0 to 60	55	70	0	90	103	
	0 to 100	76	100	0	135	155	
	0 to 160	160	200	0	270	310	
	0 to 300	250	350	0	420	482	
		Psig	Psig	Inch Hg	Psig	Psig	STANDARD MATERIAL
U.S. units	0 to 30	15	30	-30	42	48	S31600 (316 SST)
	0 to 60	30	60	-30	84	96	
	0 to 100	50	100	-30	140	160	
	0 to 200	100	200	-30	280	320	
	0 to 300	150	300	-30	420	480	
	0 to 600	300	600	0	840	960	
	0 to 1000	750	1000	0	1300	1500	
	0 to 1500	1100	1500	0	1950	2250	
	0 to 3000	2200	3000	0	3900	4500	
	0 to 5000	3700	5000	0	6000	7000	

1. Minimum or maximum span, or any span in between, may be positioned anywhere within the operating range. For example, if a 0 to 2 bar (0 to 30 psig) sensing element is used and the minimum span of 1 bar (15 psig) is set, the process indication can be calibrated to a range of -1 to 0 bar (-30 inch Hg to 0 psig), 0 to 1 bar (0 to 15 psig), 1 to 2 bar (15 to 30 psig), 2 to 3 bar (27 to 42 psig) or any value between the operating range minimum and maximum values.

2. Travel stops should be used when the maximum or minimum process pressure will be 5% over or under the calibrated range. For example, a 0 to 2 bar (0 to 30 psig) sensing element is calibrated for 0.7 to 2 bar (10 to 30 psig), the desired range. The minimum expected pressure is 0 psig and the maximum expected pressure is 2.8 bar (40 psig). Travel stops must be used to prevent excessive overtravel and undertravel since the maximum allowable overpressure and underpressure is higher than 5% of the 1.4 bar (20 psig) span which is ±70 mbar (±1 psig).

3. Bourdon tube without travel stops may be pressured to this value without permanent zero shift.

4. Bourdon tube with travel stops set may be pressured to this value without permanent zero shift.

Table 1-5. Optional Process Connections

INPUT RANGE		CONNECTION	
Bar	Psig	Size	Material
Up to 0 to 400	Up to 0 to 5000	■ 1/2 NPT external or ■ 1/2 NPT internal	■ Steel or ■ stainless steel
0 to 400 to 0 to 600	0 to 5000 to 0 to 10,000	1/2 NPT internal	Stainless steel
0 to 400 to 0 to 600	0 to 5000 to 0 to 10,000	1/2 NPT external	Stainless steel

Table 1-6. Supply Pressure Data

OUTPUT SIGNAL RANGE		NORMAL OPERATING SUPPLY PRESSURE ⁽¹⁾	MAXIMUM PRESSURE LIMIT ⁽²⁾
Bar	0.2 to 1.0	1.4	2.8
	0.4 to 2.0	2.4	2.8
Psig	3 to 15	20	40
	6 to 30	35	40

1. If this pressure is exceeded, control may be impaired.

2. If this pressure is exceeded, damage to the controller may result.

Section 2 Installation

WARNING

To avoid personal injury or property damage resulting from the sudden release of pressure:

- Always wear protective clothing, gloves, and eyewear when performing any installation operations.
- Personal injury or property damage may result from fire or explosion if natural gas is used as the supply medium and preventative measures are not taken. Preventative measures may include: Remote venting of the unit, re-evaluating the hazardous area classification, ensuring adequate ventilation, and the removal of any ignition sources. For information on remote venting of this controller, refer to page 2-5.
- Check with your process or safety engineer for any additional measures that must be taken to protect against process media.
- If installing into an existing application, also refer to the **WARNING** at the beginning of the Maintenance section of this instruction manual.

Controller Mounting Orientation

Mount the controller with the housing vertical, as shown in figure 2-1, so the vent points down.

Pipestand Mounting

Refer to figure 2-2. Pipestand mounting parts are provided to mount the controller to a 2-inch (nominal) pipe. Attach a bracket (key 68) to the controller with cap screws (key 66) and lock washers (key 67). Attach two clamps (key 69) to the bracket and fasten the controller to the pipe.

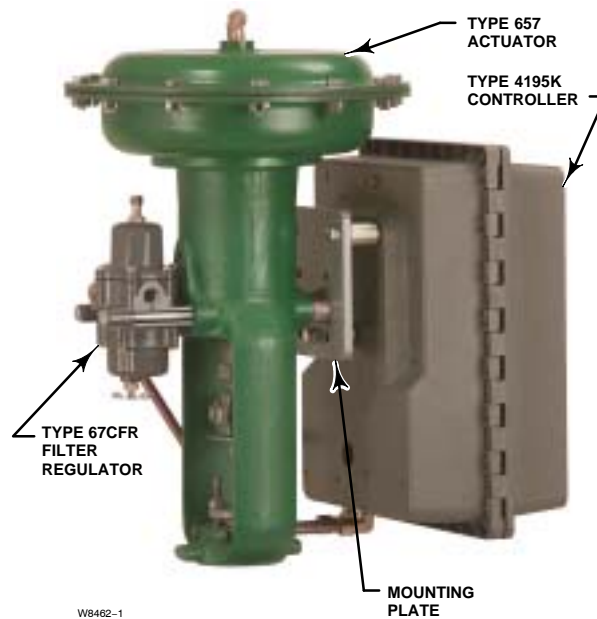

Figure 2-1. Typical Actuator Mounting

Panel Mounting

Using the dimensions shown in figure 2-3, cut a hole in the panel surface. Slide the controller into the hole and attach the bracket (key 68) to the rear of the controller using three cap screws (key 66) and lock washers (key 67). Tighten the screws (key 70) to seat the case snugly and evenly against the panel surface.

Wall Mounting

Using the dimensions in figure 2-4, drill holes in the wall to align with the four holes in the bracket (key 68). If the tubing is to run through the wall, drill a hole in the wall large enough to accept the tubing. Mount the controller to the bracket using three cap screws (key 66) and lock washers (key 67). Attach the bracket to the wall, using suitable screws or bolts.

Actuator Mounting

Refer to figure 2-1. A controller specified for mounting on a control valve actuator is mounted at the factory. If the controller is ordered separately for installation on a control valve actuator, mount the unit as described in this section. Mounting parts vary for different actuator types.

4195KA, KB, KC, and KS Controllers

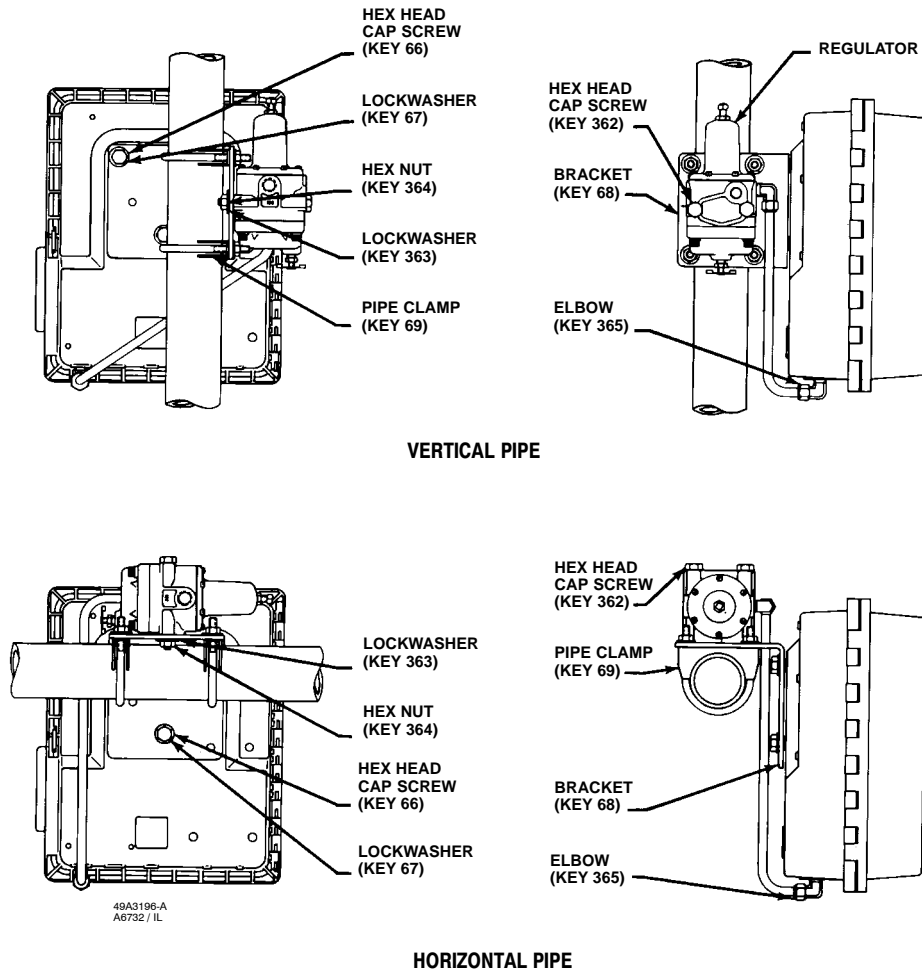

Figure 2-2. Pipestand Mounting

Attach the mounting bracket to the actuator yoke with cap screws, lock washers, and spacer spools. Attach the controller to the bracket with cap screws, lock washers, and spacer spools. On some designs, the mounting bracket is attached to the actuator casing rather than to the yoke.

system component where service conditions could exceed the limits given in this manual. Use pressure-relieving devices as required by government or accepted industry codes and good engineering practices.

Pressure Connections



To avoid personal injury or property damage resulting from the sudden release of pressure, do not install any

Refer to figure 2-5 for pressure connection locations. Supply, output, remote set point, external feedback, and vent connections are 1/4 NPT, internal. Process pressure connections are 1/4 or 1/2 NPT (optional). Use 1/4-inch or 3/8-inch pipe or tubing for supply, output, remote set point, and external feedback connections.

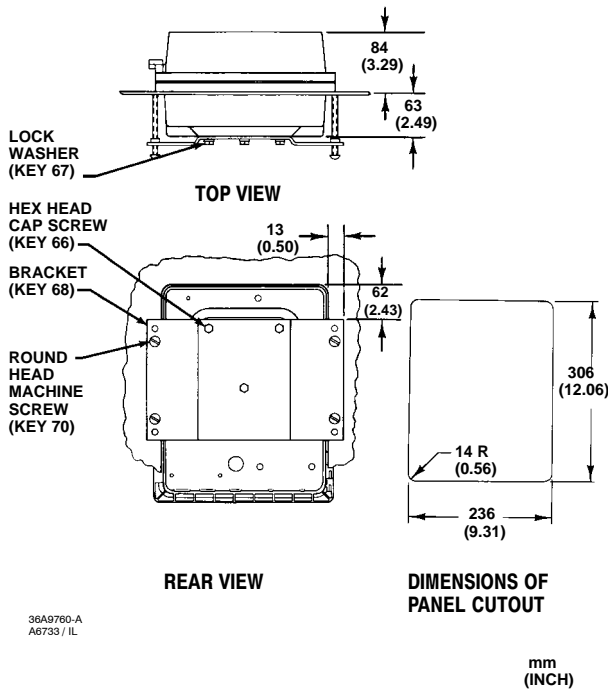

Figure 2-3. Panel Mounting

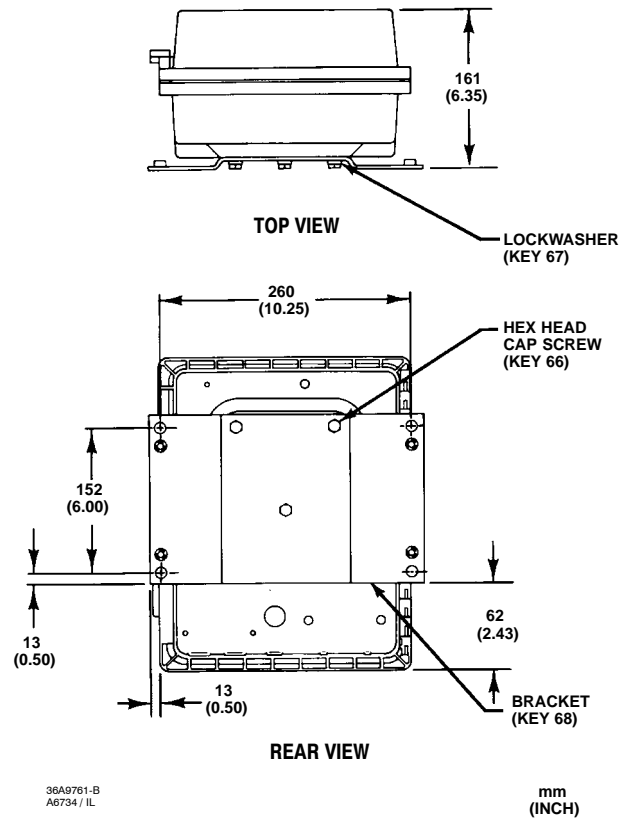

Figure 2-4. Wall Mounting

Process Pressure Connection

The connection marked A on the bottom of the case is the process input for all Bourdon tube controllers and those capsular element controllers used in vacuum pressure applications. The connection marked B is the process input for capsular element controllers used in positive pressure and compound pressure applications. See figure 2-5 for the location of the A and B connections.

When installing process piping, follow accepted practices to ensure accurate transmission of the process pressure to the controller. Install a three-valve bypass, shutoff valves, vents, drains, or seal systems as needed in the process pressure lines. If necessary, install a needle valve in a process pressure sensing line to dampen pulsations.

If the instrument is located such that the adjacent process pressure lines are approximately horizontal,

the lines should slope downward to the instrument for liquid-filled lines and upward toward the instrument for gas-filled lines. This reduces the possibility of air becoming trapped in the sensor with liquid-filled lines or of condensation becoming trapped in gas-filled lines. The recommended slope is 83 millimeters per m (1 inch per foot).

If the controller is being used in conjunction with a control valve to control pipeline pressure, connect the process pressure line in a straight section of pipe approximately 10 pipe diameters away from the valve and also away from bends, elbows, and areas of abnormal fluid velocities. For pressure-reducing service, the process pressure line must be connected downstream of the control valve. For pressure-relief service, the process pressure line must be connected upstream of the control valve.

4195KA, KB, KC, and KS Controllers

Supply Pressure Connection



WARNING

Severe personal injury or property damage may occur if the instrument air supply is not clean, dry and oil-free, or noncorrosive gas. While use and regular maintenance of a filter that removes particles larger than 40 microns in diameter will suffice in most applications, check with an Emerson Process Management field office and industry instrument air quality standards for use with corrosive gas or if you are unsure about the proper amount or method of air filtration or filter maintenance.

Supply pressure must be clean, dry air or noncorrosive gas that meets the requirements of ISA Standard S7.3. Use a suitable supply pressure regulator to reduce the supply pressure source to the normal operating supply pressure shown in table 1-6. Connect supply pressure to the SUPPLY connection on the bottom of the case, shown in figure 2-5.

Remote Set Point (suffix letter M) Pressure Connection

If the controller has remote set point (suffix letter M), connect the remote set point pressure to the top of the controller case at the location shown in figure 2-5. Use clean, dry air or noncorrosive gas. Use a 0.2 to 1.0 bar (3 to 15 psig) remote set point pressure range for a 0.2 to 1.0 bar (3 to 15 psig) controller output signal range or a 0.4 to 2.0 bar (6 to 30 psig) remote set point pressure range for a 0.4 to 2.0 bar (6 to 30 psig) controller output signal range. If pressure is supplied to the remote set point connection with a regulator, a small bleed orifice should be placed between the regulator and remote set point connection to prevent pressure variations due to regulator lock-up.

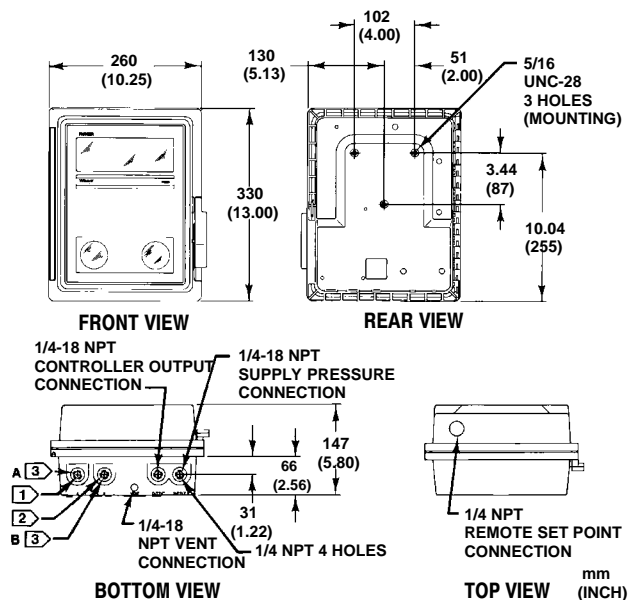

NOTES:

- ① 1/4-18 NPT PROCESS CONNECTION (MARKED A) FOR ALL BOURDON TUBE CONTROLLERS AND FOR THOSE CAPSULAR ELEMENT CONTROLLERS USED IN VACUUM PRESSURE APPLICATIONS.
- ② 1/4-18 NPT PROCESS CONNECTION (MARKED B) FOR CAPSULAR ELEMENT CONTROLLERS USED IN POSITIVE AND COMPOUND PRESSURE APPLICATIONS.
- ③ FOR THE EXTERNAL FEEDBACK CONNECTIONS (4195KB CONTROLLERS ONLY), EITHER THE A OR B CONNECTION IS USED, DEPENDING ON THE LOCATION OF THE PROCESS CONNECTION.

46A9765-A
A2892-4 / IL

Figure 2-5. Connection Locations

External Feedback Pressure Connection (4195KB Series Controllers Only)

When a secondary controller in an override application has this option, reset windup is minimized in the secondary controller. Connect the external feedback connection of the secondary controller to the output of the customer-supplied high or low select relay (see figures 2-5 and 4-9).

Vent



WARNING

Personal injury or property damage could result from fire or explosion of accumulated gas, or from contact with hazardous gas, if a flammable or hazardous gas is used as the supply pressure medium. Because the controller case and cover assembly do not form a gas-tight seal when the assembly is enclosed, a remote vent line, adequate ventilation, and necessary safety measures should be used to prevent the accumulation of flammable or hazardous gas. However, a remote vent pipe alone cannot be relied upon to remove all flammable or hazardous gas. Vent line piping should comply with local and regional codes and should be as short as possible with adequate inside diameter and few bends to reduce case pressure buildup.

CAUTION

When installing a remote vent pipe, take care not to over-tighten the pipe in the vent connection. Excessive torque will damage the threads in the connection.

If a remote vent is required, the vent line must be as short as possible with a minimum number of bends and elbows. Vent line piping should have a minimum inside diameter of 19 mm (3/4 inches) for runs up to 6.1 meters (20 feet) and a minimum inside diameter of 25 mm (1 inch) for runs from 6.1 to 30.5 meters (20 to 100 feet).

The vent must be protected against the entrance of any foreign material that could plug it; or if a remote vent is not required, the vent opening in the case must be protected against the entrance of any foreign material that could plug it. Check the vent periodically to be certain it is not plugged.

4195KA, KB, KC, and KS Controllers

Instruction Manual

Form 5207

April 2007

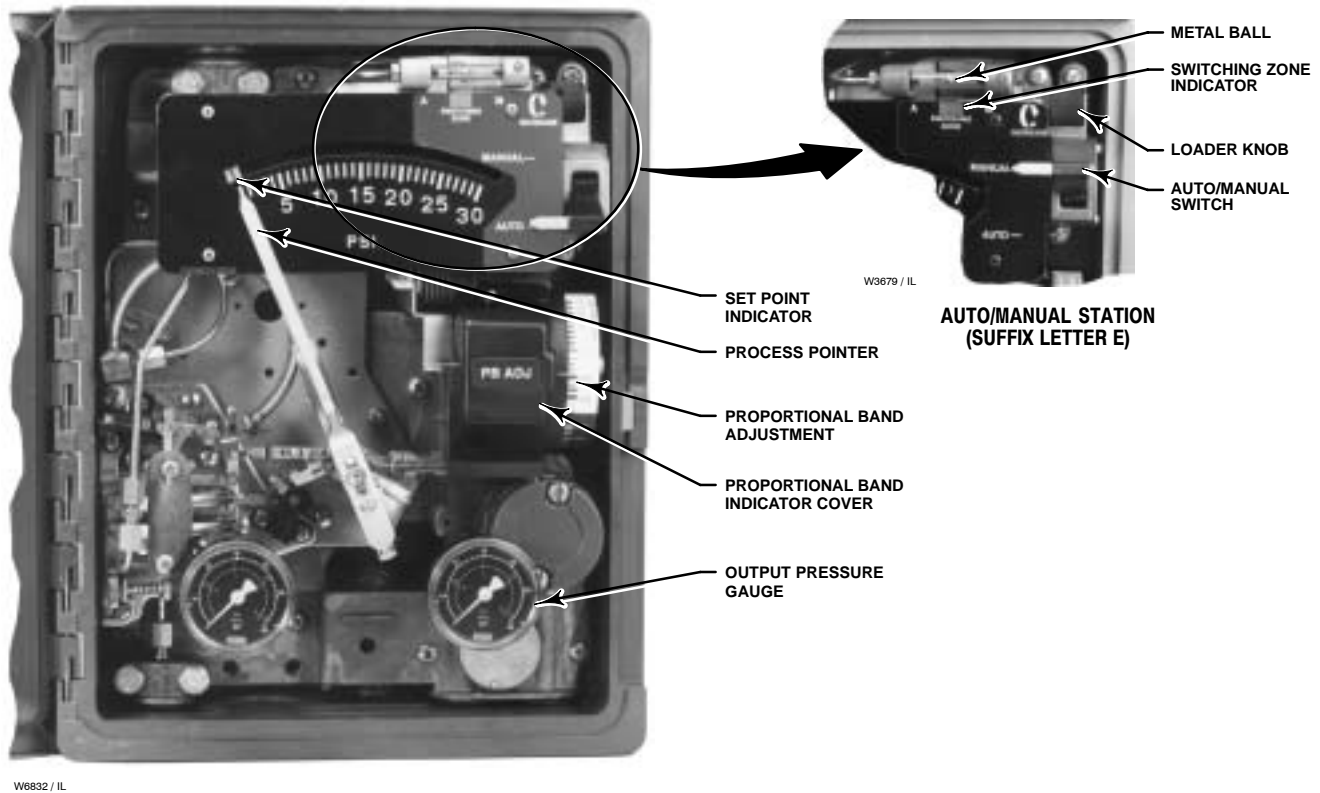

Figure 3-1. 4195KA Series Controller Adjustment Locations

Section 3 4195KA Series Proportional-Only Controllers

Adjustments for 4195KA Series Controllers

This section includes descriptions of adjustments and procedures for prestartup, startup, and calibration. Adjustment locations are shown in figures 3-1 and 3-3. To better understand the adjustments and overall controller operation, refer to the Principle of Operation section and the schematic diagrams in figures 3-4 and 3-5. Unless otherwise noted, key numbers given in this section are found in figure 7-1.

Manual Set Point Adjustment

Adjust the set point by moving the set point indicator until the line on the set point indicator is over the desired value on the process pressure scale. Move the indicator to the right to increase the set point and to the left to decrease it. Adjusting the set point does not affect the proportional band setting.

Remote Set Point (suffix letter M) Adjustment

CAUTION

Do not manually move the set point indicator on controllers with remote set point. Manually moving the set point indicator could damage the controller.

If the controller is equipped with remote set point (suffix letter M), vary the remote set point pressure to change the set point. Increase the pressure to increase the set point, and decrease the pressure to decrease the set point.

Proportional Band Adjustment (PB ADJ)

The proportional band determines the controller output sensitivity. The proportional band adjustment is marked in percentages of process pressure required to drive the controller from zero output to full output.

4195KA, KB, KC, and KS Controllers



W3439 / IL

Figure 3-2. Changing Controller Action on 4195KA Series Controllers

To adjust the proportional band, open the controller cover and locate the proportional band adjustment (PB ADJ) knob. Rotate the knob until the desired value is opposite the line on the proportional band indicator cover.

Changing Controller Action

To change the controller action from direct to reverse or vice versa, loosen the screws on the proportional band indicator cover. Lift the cover out as shown in figure 3-2 and rotate the proportional band adjustment to the desired action. Setting the proportional band to the values in the white portion of the adjustment provides direct controller action; setting proportional band in the black portion provides reverse controller action.

Bourdon Tube or Capsular Element Controllers for Positive or Compound Pressure

- **For direct control action:**

An increasing sensed pressure increases output pressure.

- **For reverse control action:**

An increasing sensed pressure decreases output pressure.

Capsular Element Controllers for Vacuum Pressure

- **For direct control action:**

An increasing sensed vacuum increases output pressure.

- **For reverse control action:**

An increasing sensed vacuum decreases output pressure.

After changing the action, tighten the screws on the proportional band indicator cover.

Switching The Auto/Manual Station (suffix letter E)

Note

Switching the controller between automatic and manual, or manual and automatic mode, without balancing the outputs, can disturb the process and cause controller cycling.

Refer to figure 3-1 if the controller has the auto/manual station (suffix letter E). To switch from automatic to manual mode, or from manual to automatic, you must first balance the manual output with the controller output. Two balance methods are available to equalize the manual output with the controller output.

To switch from automatic to manual mode, carefully adjust the loader knob until the metal ball inside the plastic tube moves into the switching zone. Then move the automatic/manual switch to MANUAL. Turn the loader knob clockwise to increase the controller output or counterclockwise to decrease it.

To switch from manual to automatic mode, adjust the set point to move the ball into the switching zone. Turn the switch to AUTO and adjust the set point to control the output.

When the auto/manual switch is in AUTO, adjusting the loader knob has no effect on the controller output. When the auto/manual switch is in MANUAL, changing the set point has no effect on the controller output.

Prestartup Checks for 4195KA Series Controllers

Refer to figure 3-1 for adjustment locations and refer to figure 7-1 for key number locations.

When performing the checks, open loop conditions must exist. An open loop exists when the controller output does not affect the input pressure or other control signal to the controller.

Note

If the controller has the auto/manual station (suffix letter E), be sure the controller is in the automatic mode before performing the prestartup checks.

1. Provide a means of measuring the controller output pressure by connecting the controller output to a pressure gauge. Connect supply pressure to the supply pressure regulator and be sure it is delivering the proper supply pressure to the controller. Do not exceed the normal operating pressure in table 1-6.
2. For a controller with remote set point (suffix letter M), connect regulated pressure of 0.2 to 1.0 bar (3 to 15 psig) or 0.4 to 2.1 bar (6 to 30 psig) to the remote set point connection at the top of the controller case.
3. Remove the two machine screws (key 6) and lift off the proportional band indicator cover (key 36).
4. Adjust the set point a minimum of 20 percent of input span above the process pointer.
5. Adjust the proportional band for 5 percent DIRECT.
6. If necessary, connect a pressure source to the process connection and adjust the process pointer to the last mark on the left side of the scale. If the last scale mark is 0 psig, a pressure source is not required.
7. The controller output pressure should be 0 bar (0 psig).
8. Rotate the proportional band to 5 percent REVERSE.
9. The controller output should be within 0.14 bar (2 psig) of the supply pressure.
10. If the controller output is within tolerance, adjust the proportional band to 400 percent in the desired action, secure the proportional band indicator cover (key 36) with the machine screws (key 6), and go to the startup procedure. If the controller output pressure is not within tolerance, go to the 4195KA Series calibration procedure for recalibration.

Startup for 4195KA Series Controllers

Perform the prestartup checks and, if necessary, calibrate the controller prior to this procedure.

Note

When performing the startup procedures, keep in mind that the initial settings are guidelines. They will vary depending on the actual process being controlled.

1. Be sure the supply pressure regulator is delivering the proper supply pressure to the controller.
2. For controllers with:

Manual set point:

Move the set point adjustment to the desired set point.

Remote set point:

- a. See figure 2-5 for the location of the remote set point connection. Connect an adjustable pressure source to the remote set point connection.
- b. Adjust the pressure source until the set point indicator reaches the desired set point. Remember: Increasing the remote set point pressure increases the set point.

3. Set the proportional band adjustment to 100 percent for fast processes. For slow processes, calculate the proportional band percentage from the equation below:

$$P.B. = \frac{200 \times \text{Allowable Overshoot}}{\text{Pressure Span}}$$

For example:

$$\frac{200 \times 0.14 \text{ bar}}{2.1 \text{ bar}} \cong 13\%$$

4. Create a load upset by momentarily changing the set point. Check for system cycling. If the system does not cycle, lower the proportional band setting (thus raising the gain) and disturb the system again by changing the set point. Continue this procedure until the system cycles. At this point, double the proportional band setting (proportional band setting $\times 2$).
5. Check the stability of the recommended proportional band setting by introducing a disturbance and monitoring the process.

4195KA, KB, KC, and KS Controllers

Calibration of 4195KA Series Controllers

WARNING

To avoid personal injury or property damage resulting from the sudden release of pressure, do not exceed the operating limits given in this manual.

General Calibration Instructions

Note

If the controller has the auto/manual station (suffix letter E), be sure the controller is in the automatic mode before performing calibration.

If the prestartup checks, or startup, reveal faulty controller operation, perform the calibration described in this section. These instructions are valid for either shop or field calibration, provided that open process loop conditions exist. Unless otherwise noted, key numbers are found in figure 7-1.

Do not use the gauges supplied with the controller during calibration. Monitor process pressure, supply pressure, controller output pressure, and if applicable, remote set point pressure with external gauges.

Process Indicator Zero and Span Calibration

Before starting this procedure:

- Provide a regulated process pressure to the controller and a means of measurement external to the controller.
- Provide a means of measuring the controller output pressure by connecting the controller output to a pressure gauge (open loop conditions must exist). Provide a regulated supply pressure to the controller. Do not exceed the normal operating pressure in table 1-6.

Refer to figures 3-1 and 3-3 for adjustment locations.

Note

Any change to the process pointer span adjustment will require

readjustment of the process pointer zero adjustment.

1. Remove the two screws (key 6) and lift off the proportional band indicator cover (key 36).
2. Set the proportional band between DIRECT and REVERSE.
3. Apply process pressure equal to the process scale span lower limit.
4. The process pointer should indicate the process scale lower limit. If not, adjust the process pointer to the process scale lower limit by loosening the zero adjustment locking screw and turning the zero adjustment screw. Tighten the zero adjustment locking screw.
5. Apply process pressure equal to the process scale span upper limit.
6. The process pointer should indicate the process scale upper limit. If not, adjust the span screw to correct one-half of the error as follows: clockwise to increase span for a low indication (below the upper limit); counterclockwise to decrease span for a high indication (above the upper limit).
7. Repeat steps 3 through 6 until the error is eliminated.
8. Apply process pressure equal to the mid-scale value of the process scale span. The process pointer should indicate the mid-scale mark, ± 2 percent of span. If the error is greater than ± 2 percent, refer to the Maintenance section and perform the appropriate zero and span adjustment procedure for a Bourdon tube or capsular element controller.
9. Adjust the process pointer to within ± 1 percent of the mid-scale mark by loosening the locking screw and turning the zero adjustment screw. This distributes the error over the entire scale span and brings all points within ± 1 percent of the process input span.
10. Apply process pressure equal to the process scale span lower limit.
11. The process pointer should indicate the process scale lower limit ± 1 percent of the scale span.
12. Apply process pressure equal to the process scale span upper limit.
13. The process pointer should indicate the process scale upper limit ± 1 percent of the scale span.
14. If the error is greater than ± 1 percent, repeat steps 3 through 13.

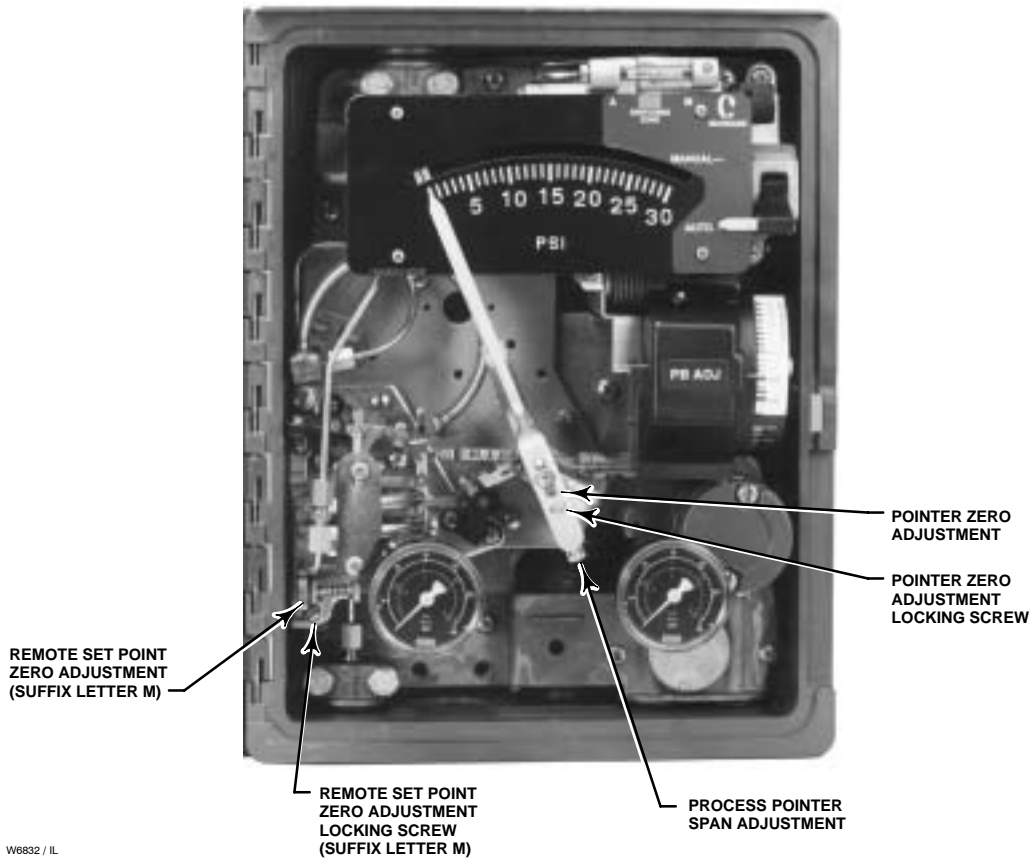

FRONT VIEW

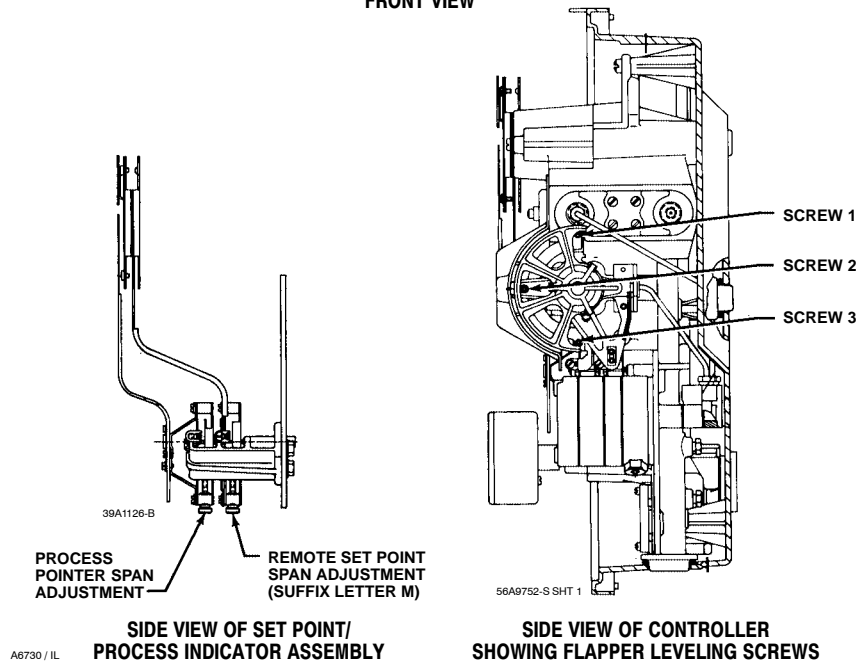

Figure 3-3. 4195KA Series Controller Calibration Adjustment Locations

4195KA, KB, KC, and KS Controllers

Remote Set Point (suffix letter M) Zero and Span Calibration

Refer to figures 3-1 and 3-3 for adjustment locations. Refer to figure 7-1 for key number locations.

Note

Any adjustment of the remote set point span adjustment screw requires readjustment of the remote set point zero adjustment screw.

1. Remove the two screws (key 6) and lift off the proportional band indicator cover (key 36).
2. Set the proportional band between DIRECT and REVERSE.
3. Apply remote set point pressure equal to the lower range limit.
4. The set point indicator should indicate the process scale lower limit. If not, loosen the remote set point zero adjustment locking screw and adjust the remote set point zero adjustment screw until the set point indicator aligns with the process scale lower limit. Tighten the zero adjustment locking screw.
5. Apply remote set point pressure equal to the upper range limit.
6. The set point indicator should indicate the process scale upper limit. If not, adjust the remote set point span adjustment screw to correct one-half the error as follows: clockwise to increase span for a low indication; counterclockwise to decrease span for a high indication.
7. Repeat steps 3 through 6 until the error is eliminated.
8. Apply remote set point pressure equal to the mid-range value.
9. Make sure the set point indicator is within ± 1 percent of the mid-scale mark and if so, proceed to step 12. If the set point indicator is not within 1 percent, but is within ± 2 percent of the mid-scale mark, then proceed with step 10. If the set point indicator is not within ± 2 percent, proceed to the remote set point calibration procedure in the Maintenance section.
10. Loosen the remote set point zero adjustment locking screw and adjust the remote set point zero adjustment screw to correct for half the error at mid-scale. Tighten the zero adjustment locking screw.
11. Apply remote set point pressure equal to the lower and upper range limits and make sure the set point indicator is within ± 1 percent.
12. If necessary, perform the process indicator zero and span calibration procedure in this section. Otherwise, perform the flapper alignment procedure in this section.

Flapper Alignment

Note

Perform the process indicator zero and span calibration procedure and, for controllers with remote set point (suffix letter M), the remote set point zero and span calibration procedure before the flapper alignment.

Flapper leveling screw numbers and adjustments are shown in figure 3-3. Key number locations are shown in figure 7-1.

Provide a means of measuring the controller output pressure by connecting the controller output to a pressure gauge (open-loop conditions must exist). Provide a regulated supply pressure to the controller. Do not exceed the normal operating pressure in table 1-6. After performing the flapper alignment procedure, go to the startup procedure.

1. For a controller with manual set point, move the set point indicator to the mid-scale mark on the process scale. For a controller with remote set point (suffix letter M), adjust the remote set point pressure until the set point indicator is at the mid-scale mark on the process scale.
2. Apply process pressure equal to the mid-scale value of the process scale span. If pressure is not available to pressure the input element to the mid-scale value, an alternate method is to disconnect link number 1 at the input element and tape the process pointer at the mid-scale mark on the process scale. If the controller has a capsular input element, note the hole from which link number 1 was removed for proper replacement. This method should only be used if pressure is not available to pressure the input element to the mid-scale value.
3. Remove the two machine screws (key 6) and lift off the proportional band indicator cover (key 36).
4. Adjust the proportional band between DIRECT and REVERSE.
5. The controller output should be 0.62 ± 0.007 bar (9 ± 0.10 psig) for a 0.2 to 1.0 bar (3 to 15 psig) output or 1.2 ± 0.01 bar (18 ± 0.2 psig) for a 0.4 to 2.0 bar (6 to 30 psig) output. If not, adjust flapper leveling screw 2 (the screw nearest the nozzle) until the output is within tolerance.
6. Set the proportional band to 30 percent DIRECT.

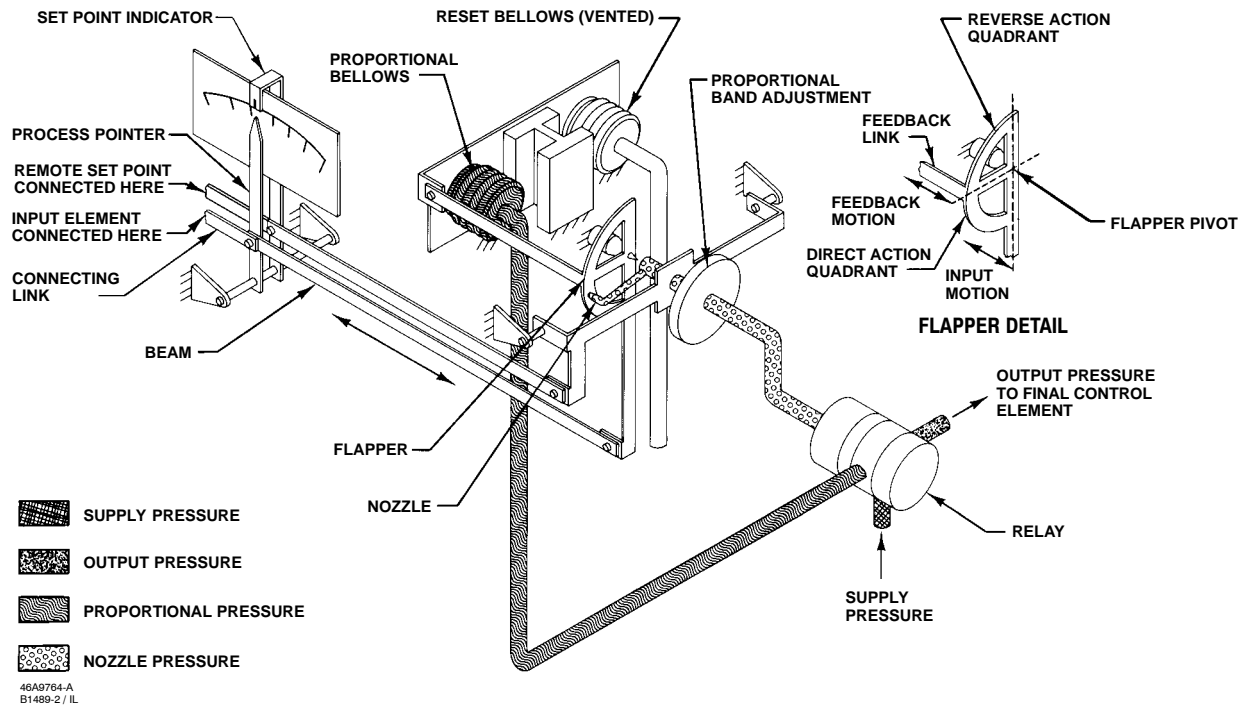

Figure 3-4. 4195KA Series Controller Schematic

7. The controller output should be 0.62 ± 0.02 bar (9 ± 0.25 psig) or 1.2 ± 0.04 bar (18 ± 0.5 psig). If not, adjust flapper leveling screw 3 (the screw nearest the nozzle).

8. Set the proportional band to 30 percent REVERSE.

9. The controller output should be 0.62 ± 0.02 bar (9 ± 0.25 psig) or 1.2 ± 0.04 bar (18 ± 0.5 psig). If not, adjust flapper leveling screw 1 (the screw nearest the nozzle).

10. Repeat steps 4 through 9 until the controller output remains in tolerance without further leveling screw adjustments.

11. If link 1 was disconnected, remove the tape and reconnect link 1 to the input element.

12. Set the proportional band to 400 percent in the desired controller action and replace the proportional band indicator cover.

Principle of Operation for 4195KA Series Controllers

Overall Operation

Refer to the schematic diagram in figure 3-4.

The input element is connected to the process pointer and to the flapper by connecting links. As the process pressure increases (in a direct-acting controller), the flapper moves toward the nozzle, restricting flow through the nozzle and increasing nozzle pressure. When this occurs, relay action increases the output pressure (delivery) of the controller. Output pressure is fed back to the proportional bellows. The action of the proportional bellows counteracts the flapper movement that resulted from the process pressure change and backs the flapper away from the nozzle until equilibrium is reached.

Moving the set point indicator changes the distance between the nozzle and flapper as does a change in process pressure, except that when the set point is changed, the nozzle moves with respect to the flapper.

The proportional band adjustment positions the nozzle on the flapper. Increasing (widening) the proportional band moves the nozzle to a position on

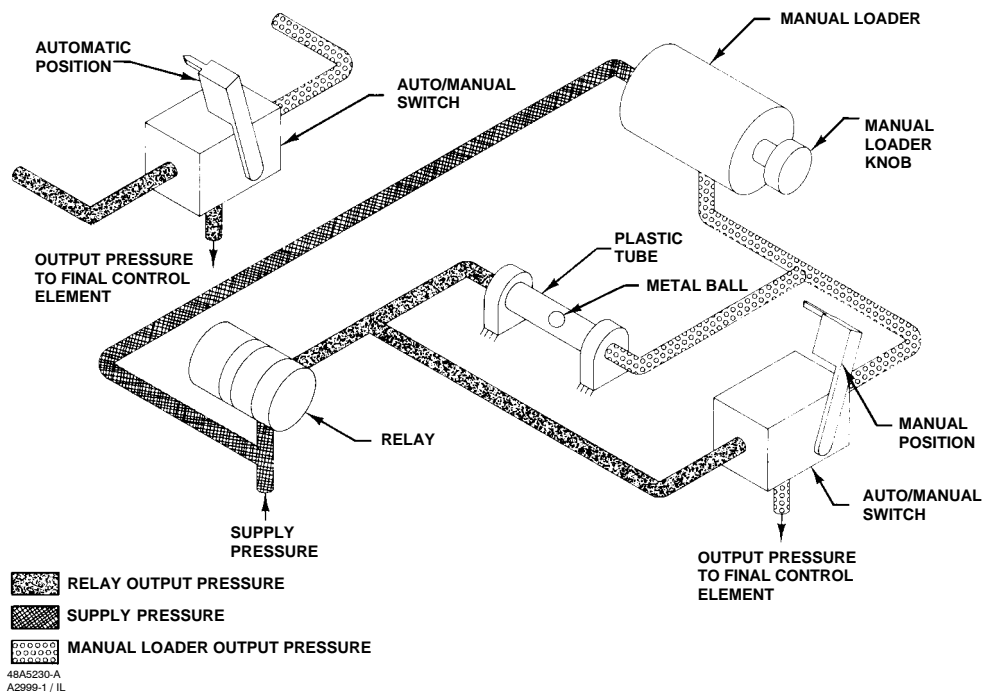

Figure 3-5. 4195KA Series Auto/Manual Station Schematic

the flapper where less input and more feedback motion occurs, which decreases the gain of the controller. Decreasing (narrowing) the proportional band moves the nozzle toward a position where more input and less feedback motion occurs, which increases the gain. The controller action is changed from direct to reverse by turning the proportional band adjustment to position the nozzle on the flapper quadrant to a point where the direction of the flapper motion versus input motion is reversed as shown in the flapper detail of figure 3-4. With the controller in the reverse-acting mode, an increase in process pressure causes a decrease in output pressure.

Remote Set Point (suffix letter M) Operation

The capability to adjust the controller set point from a remote location is available with all 4195KA Series controllers. This option is designated by the letter M in the type number.

A control pressure is applied to the capsular element within the remote set point assembly. The expansion and contraction of the capsule moves the set point adjustment via a connecting linkage. Increasing the control pressure to the capsule increases the set point setting and decreasing the control pressure reduces the set point setting.

Auto/Manual Station (suffix letter E) Operation

A controller with the auto/manual station (designated by the suffix letter E in the type number) has piping on the output side of the relay as shown in figure 3-5. Supply pressure to the relay is also applied to the manual loader. The manual loader, functioning as a regulator, applies pressure to one side of the plastic tube and to the auto/manual switch. Output pressure from the relay registers on the other side of the plastic tube as well as in the auto/manual switch.

When the auto/manual switch is in the MANUAL position, the manual loader output is channeled through the auto/manual switch and becomes the controller output. When the auto/manual switch is in the AUTO position, the relay output is channeled through the switch to become the controller output.

Before the auto/manual switch is operated, the relay output must equal the manual loader output to avoid bumping the process. Adjusting the set point varies the pressure on the left-hand side of the plastic tube. Adjusting the manual loader knob varies the pressure on the right-hand side. When the pressures are equal, the metal ball is centered in the tube and it is held in place by a small magnet. A pressure imbalance forces the ball to one end of the tube where it forms a seal, blocking air flow through the tube.

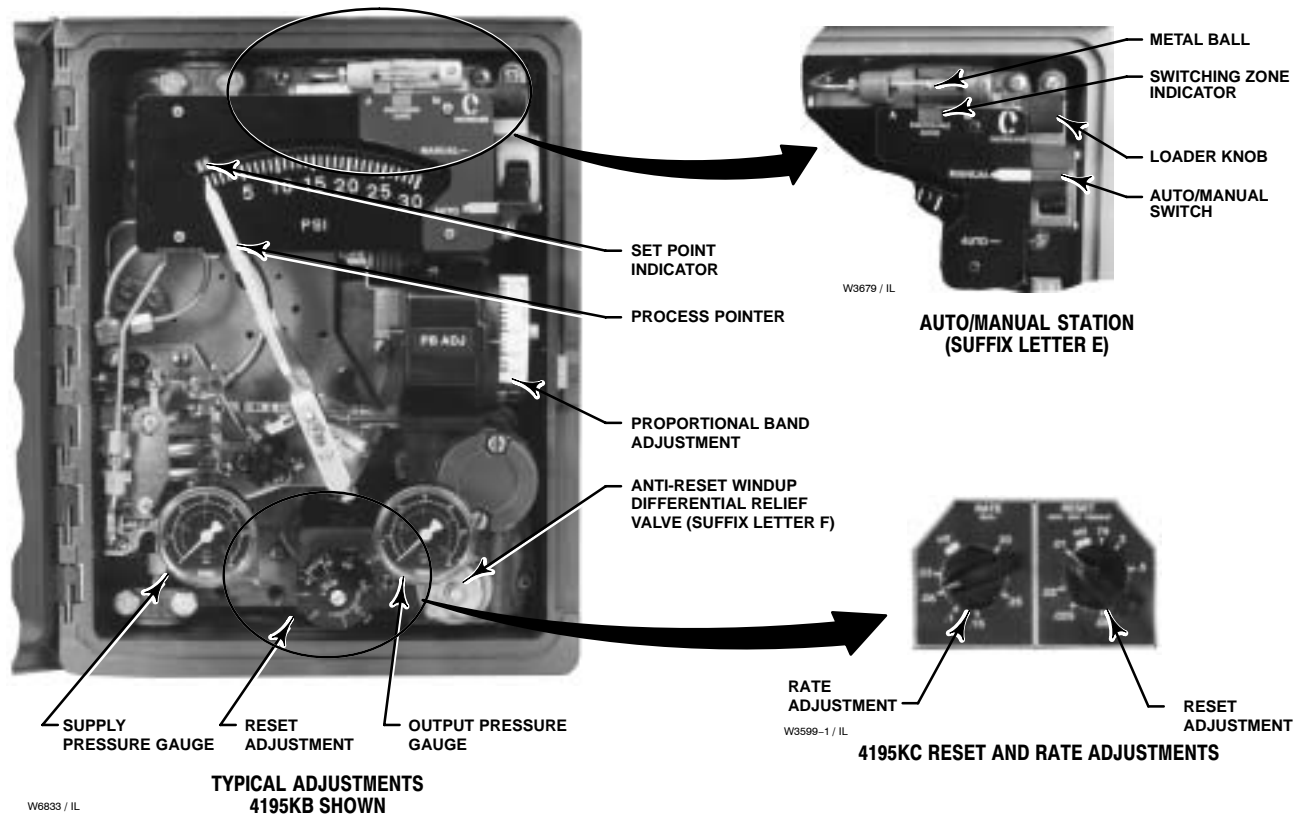

Figure 4-1. 4195KB and KC Series Controller Adjustment Locations

Section 4 4195KB Series Proportional-Plus-Reset Controllers and 4195KC Series Proportional-Plus-Reset-Plus-Rate Controllers

Adjustments for 4195KB and KC Series Controllers

This section includes descriptions of adjustments and procedures for prestartup, startup, and calibration. Adjustment locations are shown in figures 4-1 and 4-3. To better understand the adjustments and overall controller operation, refer to the Principle of Operation section and to the schematic diagrams in figures 4-5 through 4-9. Unless otherwise noted, key numbers given in this section are found in figure 7-1.

Manual Set Point Adjustment

Adjust the set point by opening the controller cover and moving the set point indicator until the line on

the set point indicator is over the desired value on the process pressure scale. Move the indicator to the right to increase the set point and to the left to decrease it. Adjusting the set point does not affect the proportional band setting.

Remote Set Point (suffix letter M) Adjustment

CAUTION

Do not manually move the set point indicator on a controller with remote set point. Manually moving the set point indicator could damage the controller.

If the controller is equipped with remote set point (suffix letter M), vary the remote set point pressure to change the set point. Increase the pressure to increase the set point and decrease the pressure to decrease the set point.

4195KA, KB, KC, and KS Controllers



W3439 / IL

Figure 4-2. Changing Controller Action on 4195KB and KC Series Controllers

Proportional Band Adjustment (PB ADJ)

The proportional band determines the controller output sensitivity. The proportional band adjustment is marked in percentages of process pressure required to drive the controller from zero output to full output.

To adjust the proportional band, open the controller cover and locate the proportional band adjustment (PB ADJ) knob. Rotate the knob until the desired value is opposite the line on the proportional band indicator cover.

Changing Controller Action

To change the controller action from direct to reverse or vice versa, loosen the screws on the proportional band indicator cover. Lift the cover out as shown in figure 4-2 and rotate the proportional band adjustment to the desired action. Setting the proportional band to the values in the white portion of the adjustment provides direct controller action; setting proportional band in the black portion provides reverse controller action.

Bourdon Tube or Capsular Element Controllers for Positive or Compound Pressure

- **For direct control action:**

An increasing sensed pressure increases output pressure.

- **For reverse control action:**

An increasing sensed pressure decreases output pressure.

Capsular Element Controllers for Vacuum Pressure

- **For direct control action:**

An increasing sensed vacuum increases output pressure.

- **For reverse control action:**

An increasing sensed vacuum decreases output pressure.

After changing the action, tighten the screws on the proportional band indicator cover.

Reset Adjustment

To adjust reset, open the controller cover and locate the RESET adjustment. Rotate the adjustment clockwise to decrease the minutes per repeat or counterclockwise to increase the minutes per repeat. Increasing the minutes per repeat provides a slower reset action.

Rate Adjustment

To adjust rate, open the controller cover and locate the RATE adjustment. Rotate the adjustment clockwise to decrease the minutes (less rate action) or counterclockwise to increase the minutes (more rate action).

Anti-Reset Windup (suffix letter F) Adjustment

If the arrow on the relief valve points toward the bottom of the controller case, as shown in figure 4-1, the valve opens with increasing controller output pressure. If the arrow points in the opposite direction, the relief valve opens with decreasing controller output pressure. Differential relief pressure is factory set at 0.3 bar (5 psig). Maximum relief pressure is 0.5 bar (7 psig). The minimum is 0.1 bar (2 psig).

Turn the adjusting screw counterclockwise to increase differential relief pressure, clockwise to decrease it.

Switching the Auto/Manual Station (suffix letter E)

Note

Switching the controller between automatic and manual, or manual and automatic mode, without balancing the outputs, can disturb the process and cause controller cycling.

Refer to figure 4-1 if the controller has the auto/manual station (suffix letter E). To switch from automatic to manual mode, or from manual to automatic, you must first balance the manual output with the controller output. Two balance methods are available to equalize the manual output with the controller output.

To switch from automatic to manual mode, carefully adjust the loader knob until the metal ball inside the plastic tube moves into the switching zone. Then move the automatic/manual switch to MANUAL. Turn the loader knob clockwise to increase the controller output or counterclockwise to decrease it.

To switch from manual to automatic mode, adjust the set point to move the ball into the switching zone. Turn the switch to AUTO and adjust the set point to control the output.

When the automatic/manual switch is in AUTO, adjusting the loader knob has no effect on the controller output. When the automatic/manual switch is in MANUAL, changing the set point has no effect on the controller output.

Prestartup Checks for 4195KB and KC Series Controllers

Refer to figure 4-1 for adjustment locations, and refer to figure 7-1 for key number locations.

When performing the checks, open loop conditions must exist. An open loop exists when the controller output does not affect the input pressure or other control signal to the controller.

Note

If the controller has the auto/manual station (suffix letter E), be sure the controller is in the automatic mode before performing prestartup checks. If the controller has the external feedback option, connect the

controller output connection to the external feedback connection (see figure 2-5). Adjust the controller for full output pressure and with the RESET knob adjusted to 0.01 minutes/repeat, verify the tubing connections do not leak. Disconnect after completing the prestartup checks.

1. Provide a means of measuring the controller output pressure by connecting the controller output to a pressure gauge. Connect supply pressure to the supply pressure regulator and be sure it is delivering the proper supply pressure to the controller. Do not exceed the normal operating pressure in table 1-6.
2. For a controller with remote set point (suffix letter M), connect regulated pressure of 0.2 to 1.0 bar (3 to 15 psig) or 0.4 to 2.1 bar (6 to 30 psig) to the remote set point connection at the top of the controller case.
3. Remove the two machine screws (key 6) and lift off the proportional band indicator cover (key 36).
4. Adjust the set point a minimum of 20 percent of input span above the process pointer.
5. Turn the reset adjustment to 0.01 minutes per repeat.
6. Turn the rate adjustment to OFF (4195KC Series).
7. Adjust the proportional band for 5 percent DIRECT.
8. If necessary, connect a pressure source to the process connection and adjust the process pointer to the last mark on the left side of the scale. If the last scale mark is 0 bar (0 psig), a pressure source is not required.
9. The controller output pressure should be 0 bar (0 psig).
10. Rotate the proportional band to 5 percent REVERSE.
11. The controller output should be within 0.14 bar (2 psig) of the supply pressure.
12. If the controller output is within tolerance, adjust the proportional band to 400 percent in the desired action. Secure the proportional band indicator cover (key 36) with the machine screws (key 6), and go to the startup procedure. If the controller output pressure is not within tolerance, go to the 4195KB and KC Series calibration procedure for recalibration.

4195KA, KB, KC, and KS Controllers

Startup for 4195KB and KC Series Controllers

Perform the prestartup checks and, if necessary, calibrate the controller prior to this procedure.

Note

When performing the startup procedures, keep in mind that the initial settings are guidelines. They will vary depending on the actual process being controlled.

1. Be sure the supply pressure regulator is delivering the proper supply pressure to the controller.

2. For controllers with:

Manual set point:

Move the set point indicator to the desired set point.

Remote set point:

a. See figure 2-5 for the location of the remote set point connection. Connect an adjustable pressure source to the remote set point connection.

b. Adjust the pressure source until the set point indicator reaches the desired set point. Remember: Increasing the remote set point pressure increases the set point.

3. Set the reset adjustment to 0.05 minutes per repeat for fast processes. Set it to 0.5 minutes per repeat for slow processes. For controllers with rate, set the rate adjustment to OFF.

4. Set the proportional band to 100 percent for fast processes. For slow processes, calculate the proportional band percentage from the equation below:

$$P.B. = \frac{200 \times \text{Allowable Overshoot}}{\text{Pressure Span}}$$

For example:

$$\frac{200 \times 0.14 \text{ bar}}{2.1 \text{ bar}} \cong 13\%$$

5. If the controller is used in conjunction with a control valve, return the control valve to service by slowly opening the upstream and downstream manual control valves in the pipeline. Close the manual bypass valve, if one is used.

6. Tune the various controller actions.

Tuning proportional action: Create a load upset by momentarily changing the set point. Check for system cycling. If the system does not cycle, lower the proportional band setting (thus raising the gain) and disturb the system again by changing the set point. Continue this procedure until the system cycles. At this point, double the proportional band setting (proportional band setting $\times 2$).

Tuning reset action: Disturb the system. If the system does not cycle, speed up the reset by changing the setting to a lower value (faster reset). Disturb the system again. Continue this procedure until the system cycles. When the system cycles, multiply the reset time setting by a factor of three (reset setting $\times 3$) and slow down the reset by changing the reset setting to the higher value. The reset is now tuned.

Tuning rate action: For a controller with rate (4195KC Series), adjust the rate toward the higher setting until cycling occurs. When the system cycles, divide the rate value by a factor of three (rate setting $\div 3$) and decrease the rate by changing the setting to the lower value. The rate is now tuned.

7. Check the stability of the recommended proportional band setting by introducing a disturbance and monitoring the process.

8. Once stable control is attained, the process pointer and set point indicator should be in line. If they are aligned, return the set point to the desired value. If they are not, readjust the set point to the desired control point and proceed with step 9.

9. If the process pointer is within 5 percent of the set point indicator, turn the link 3 adjustment (see figure 6-13 or 6-21 for location) until the process pointer aligns with the set point indicator. Turn the link 3 adjustment screw clockwise to increase the process indication or counterclockwise to decrease it. If the process pointer is misaligned with the set point indicator by more than 5 percent of the scale span, perform the calibration procedures for 4195KB and KC Series controllers.

Calibration of 4195KB and KC Series Controllers



To avoid personal injury or property damage resulting from the sudden release of pressure, do not exceed the operating limits given in this manual.

General Calibration Instructions

Note

If the controller has the auto/manual station (suffix letter E), be sure the controller is in the automatic mode before performing calibration.

If the prestartup checks, or startup, reveal faulty controller operation, perform the calibration described in this section. These instructions are valid for either shop or field calibration, provided that open loop conditions exist. Unless otherwise noted, key numbers are found in figure 7-1.

Do not use the gauges supplied with the controller during calibration. Monitor process pressure, supply pressure, controller output pressure, and if applicable, remote set point pressure with external gauges.

Process Indicator Zero and Span Calibration

Before starting this procedure:

- Provide a regulated process pressure to the controller and a means of measurement external to the controller.
- Provide a means of measuring the controller output pressure by connecting the controller output to a pressure gauge (open-loop conditions must exist). Provide a regulated supply pressure to the controller. Do not exceed the normal operating pressure in table 1-6.

Refer to figures 4-1 and 4-3 for adjustment locations.

Note

Any change to the process pointer span adjustment will require readjustment of the process pointer zero adjustment.

1. Remove the two screws (key 6) and lift off the proportional band indicator cover (key 36).
2. Set the proportional band between DIRECT and REVERSE.
3. Apply process pressure equal to the process scale span lower limit.
4. The process pointer should indicate the process scale lower limit. If not, adjust the process pointer to the process scale lower limit by loosening the zero adjustment locking screw and turning the zero

adjustment screw. Tighten the zero adjustment locking screw.

5. Apply process pressure equal to the process scale span upper limit.
6. The process pointer should indicate the process scale upper limit. If not, adjust the process pointer span screw to correct one-half the error as follows: clockwise to increase span for a low indication (below the upper limit); counterclockwise to decrease span for a high indication (above the upper limit).
7. Repeat steps 3 through 6 until the error is eliminated.
8. Apply process pressure equal to the mid-scale value on the process scale span. The process pointer should indicate the mid-scale mark, ± 2 percent of span. If the error is greater than ± 2 percent, refer to the Maintenance section and perform the appropriate zero and span adjustment procedure for Bourdon tube or capsular element controllers.
9. Adjust the process pointer to within ± 1 percent of the mid-scale mark by loosening the zero adjustment locking screw and turning the zero adjustment screw. This distributes the error over the entire scale range and brings all points within ± 1 percent of the process scale span.
10. Apply process pressure equal to the process scale lower limit.
11. The process pointer should indicate the process scale lower limit ± 1 percent of the scale span.
12. Apply process pressure equal to the process scale upper limit.
13. The process pointer should indicate the process scale upper limit ± 1 percent of the process scale span.
14. If the error is greater than ± 1 percent, repeat steps 3 through 13.

Remote Set Point (suffix letter M) Zero and Span Calibration

Refer to figures 4-1 and 4-3 for adjustment locations. Refer to figure 7-1 for key number locations.

Note

Any adjustment of the remote set point span adjustment screw requires readjustment of the remote set point zero adjustment screw.

1. Remove the two screws (key 6) and lift off the proportional band indicator cover (key 36).

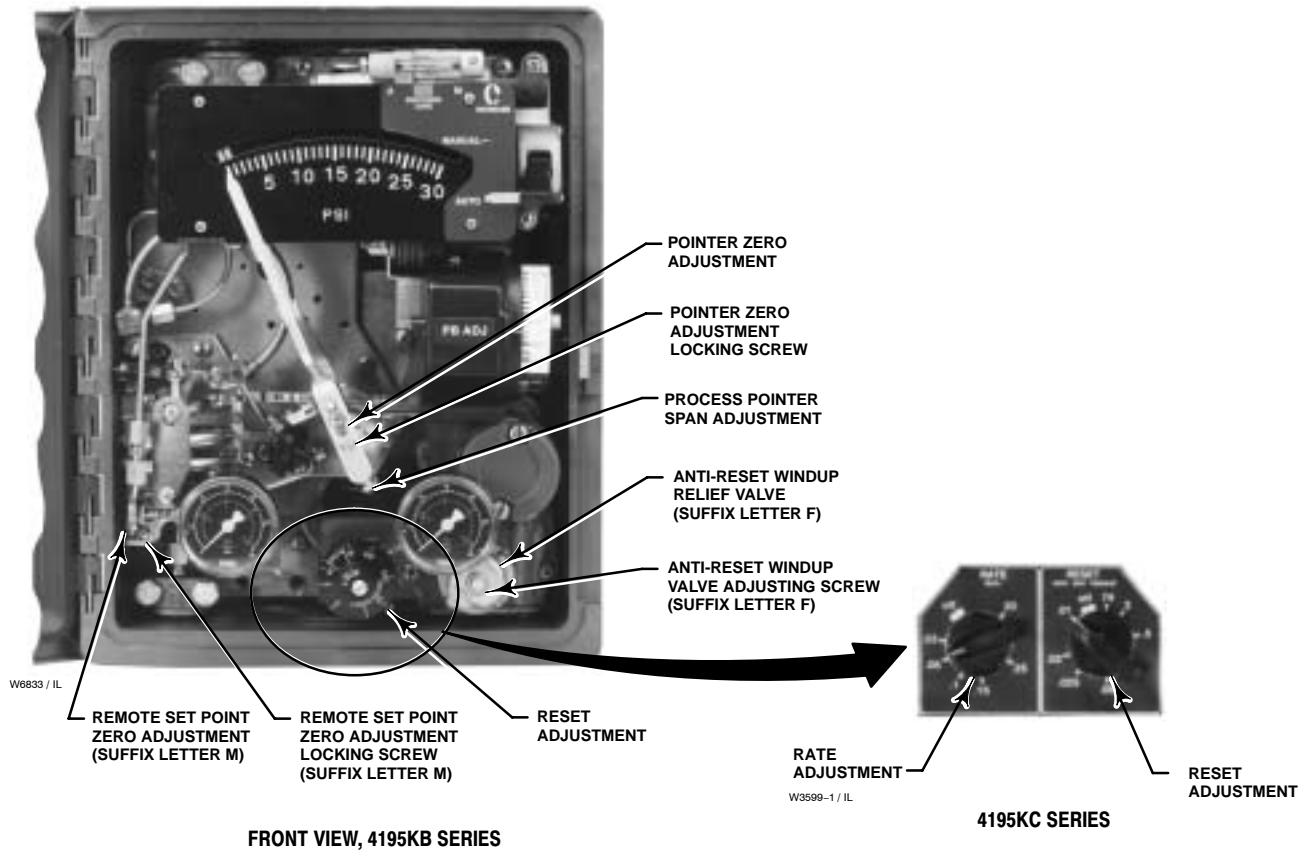

FRONT VIEW, 4195KB SERIES

4195KC SERIES

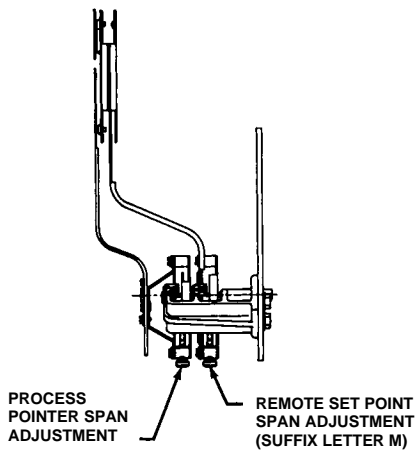

SIDE VIEW OF SET POINT/PROCESS INDICATOR ASSEMBLY

39A1126-B
A6731 / IL

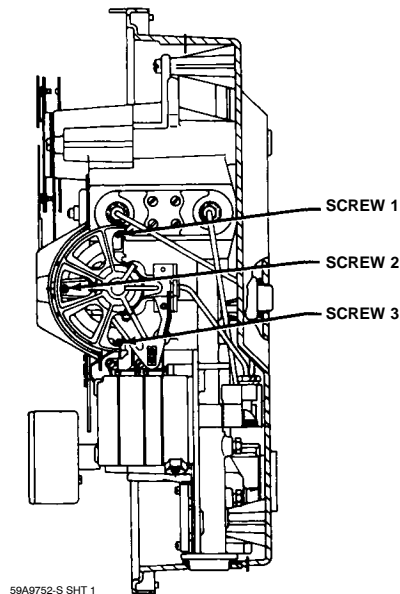

SIDE VIEW OF CONTROLLER SHOWING FLAPPER LEVELING SCREWS

59A9752-S SHT 1

Figure 4-3. 4195KB and KC Series Controller Calibration Adjustment Locations

2. Set the proportional band between DIRECT and REVERSE.
3. Apply remote set point pressure equal to the lower range limit.
4. The set point indicator should indicate the process scale lower limit. If not, loosen the remote set point zero adjustment locking screw and adjust the remote set point zero adjustment screw until the set point indicator aligns with the process scale lower limit. Tighten the zero adjustment locking screw.
5. Apply remote set point pressure equal to the upper range limit.
6. The set point indicator should indicate the process scale upper limit. If not, adjust the remote set point span adjustment screw to correct one-half the error as follows: clockwise to increase span for a low indication; counterclockwise to decrease span for a high indication.
7. Repeat steps 3 through 6 until the error is eliminated.
8. Adjust the remote set point pressure to the mid-range value.
9. Make sure the set point indicator is within ± 1 percent of the mid-scale mark, and if so, proceed to step 12. If the set point indicator is not within 1 percent, but is within ± 2 percent of the mid-scale mark, proceed with step 10. If the set point indicator is not within ± 2 percent, proceed to the remote set point zero and span adjustment procedure in the Maintenance section.
10. Loosen the remote set point zero adjustment locking screw and adjust the remote set point zero adjustment screw to correct for half the error at mid scale. Tighten the zero adjustment locking screw.
11. Apply remote set point pressure equal to the lower and upper range limits and make sure the set point indicator is within ± 1 percent.
12. If necessary, perform the process indicator zero and span calibration procedure in this section. Otherwise, perform the flapper alignment procedure in this section.

Flapper Alignment

Note

Perform the process indicator zero and span calibration procedure and, for controllers with remote set point (suffix letter M), the remote set point

zero and span calibration procedure before the flapper alignment.

Flapper leveling screw numbers and adjustments are shown in figure 4-3. Key number locations are shown in figure 7-1.

Provide a means of measuring the controller output pressure by connecting the controller output to a pressure gauge (open-loop conditions must exist). Do not apply supply pressure at this time.

Note

4195KB and KC Series controllers with anti-reset windup (suffix letter F) are supplied with two O-rings (key 52), valve cover (key 51), and two machine screws (key 53). Use these parts in the next step.

1. For controllers with anti-reset windup (suffix letter F), record the direction of the arrow on the anti-reset windup relief valve (key 55). Remove the relief valve and install the two O-rings (key 52) and valve cover (key 51) supplied with the controller. Secure the valve cover with the two machine screws (key 53) provided.
2. If necessary, remove the two machine screws (key 6) and lift off the proportional band indicator cover (key 36).
3. If the controller has the external feedback option (available with the 4195KB Series only), connect the controller output to the external feedback connection. See figure 2-5 for the location of the output and external feedback connections.
4. Provide regulated supply pressure to the controller. Do not exceed the normal operating pressure in table 1-6.
5. For a controller with manual set point, move the set point indicator to the mid-scale mark on the process scale. For a controller with remote set point (suffix letter M), adjust the remote set point pressure until the set point indicator is at the mid-scale mark on the process scale.
6. Set the reset adjustment to 0.01 minutes per repeat.
7. If the controller has rate (4195KC Series), turn the rate adjustment to OFF.
8. Apply process pressure equal to the mid-scale value of the process scale span. If pressure is not available to pressure the input element to mid-scale value, an alternate method is to disconnect link number 1 at the input element and tape the process pointer at mid-scale mark on the process scale. If

4195KA, KB, KC, and KS Controllers

the controller has a capsular input element, note the hole where link number 1 is connected to the input element, then disconnect link 1. This method should only be used if pressure is not available to pressure the input element to the mid-scale value.

Note

Because of the high controller gain, the controller output will not remain stable in steps 9 through 13. The controller output gauge is adequate to check the output pressure during this procedure.

9. Set the proportional band between DIRECT and REVERSE.

10. The controller output should be relatively stable at any value within the output range. If not, adjust flapper leveling screw 2 (the screw nearest the nozzle) until the output is relatively stable.

11. Set the proportional band to 30 percent DIRECT. The controller output should be relatively stable at any value within the output range. If not, adjust flapper leveling screw 3 (the screw nearest the nozzle) until the output is relatively stable.

12. Set the proportional band to 30 percent REVERSE. The controller output should be relatively stable at any value within the output range. If not, adjust flapper leveling screw 1 (the screw nearest the nozzle) until the output is relatively stable.

13. Repeat steps 9 through 12 until the controller output remains relatively stable without further flapper leveling screw adjustment.

Note

Steps 14 through 20 check the flapper alignment.

14. Set the proportional band to 30 percent DIRECT.

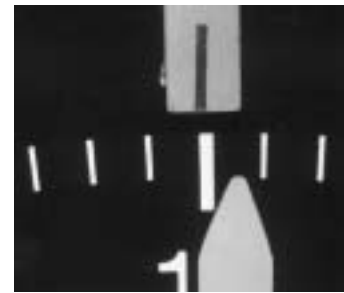

W4039 / IL
RIGHT-HAND EDGE



W4038 / IL
LEFT-HAND EDGE

Figure 4-4. Alignment of the Process Pointer with the Set Point Indicator

15. Apply process pressure to the input element or, if link 1 was disconnected, remove the tape from the process pointer and move the pointer until it aligns with the right-hand edge of the set point indicator as shown in figure 4-4.

The controller output should be within 0.14 bar (2 psig) of the supply pressure.

16. Apply process pressure to the input element or, if disconnected, move the process pointer until it aligns with the left-hand edge of the set point indicator as shown in figure 4-4.

The controller output pressure should go to 0 bar (0 psig).

17. Set the proportional band to 30 percent REVERSE.

18. Apply process pressure to the input element or, if disconnected, move the process pointer until it aligns with the right-hand edge of the set point indicator as shown in figure 4-4. The controller output should be 0 bar (0 psig).

19. Apply process pressure to the input element or, if disconnected, move the process pointer until it aligns with the left-hand edge of the set point indicator as shown in figure 4-4. The controller output should be within 0.14 bar (2 psig) of the supply pressure.

20. If the controller does not perform as indicated in steps 14 through 19, the flapper is not correctly

aligned. This may occur because the output was not sufficiently stabilized in steps 9 through 13. Repeat steps 8 through 19.

21. When the flapper is correctly aligned, set the proportional band to 400 percent in the desired controller action and replace the proportional band indicator cover. If link 1 was disconnected, reconnect link 1 to the input element using the same hole noted in step 8.

22. Remove supply pressure.

23. If the controller has the external feedback option, disconnect the outside tubing which connects the external feedback connection to the output connection.

24. For controllers with anti-reset windup (suffix letter F), remove the two machine screws, valve cover and two O-rings installed in step 1 of this procedure. Install the anti-reset windup relief valve (key 55) with the arrow pointing in the direction recorded in step 1.

Anti-Reset Windup (suffix letter F) Differential Relief Valve Calibration

Calibration for the differential relief valve to relieve on rising controller output pressure

1. Provide a means of measuring the controller output pressure by connecting the controller output to a pressure gauge (open-loop conditions must exist). Do not apply supply pressure at this time.
2. Set the reset adjustment to 0.01 minutes per repeat (wide open) and the rate adjustment (4195KC Series only) to the OFF position.
3. For a controller with manual set point, move the set point indicator to the mid-scale mark on the process scale. For a controller with remote set point, adjust the remote set point pressure until the set point indicator is at the mid-scale mark on the process scale.
4. Set the proportional band to 100 percent in either the DIRECT or REVERSE action depending on the application requirements.
5. Refer to figure 4-3 for the location of the anti-reset windup differential relief valve. For the differential relief valve to relieve on rising controller output pressure, install the valve so the arrow on the valve points down. To change the direction of the arrow, loosen the two mounting screws, pull the valve out, and reinstall the valve with the arrow pointing down. Tighten the two mounting screws.

6. Provide a regulated supply pressure to the controller. Do not exceed the normal operating pressure in table 1-6.

Note

Because of the high controller gain with the reset adjustment at 0.01 minutes per repeat, the controller output will not balance perfectly in the following step. If the controller output is stable for approximately 5 seconds, it is adequately balanced.

7. Increase the process pressure (or vacuum for a vacuum controller) to the controller until the controller output pressure balances at 0.4 bar (6 psig) for a 0.2 to 1.0 bar (3 to 15 psig) output range or 0.8 bar (12 psig) for a 0.4 to 2.0 bar (6 to 30 psig) output range.
8. Turn the reset adjustment to the CLOSED (4195KB Series) or OFF (4195KC Series) position.
9. Increase the controller output pressure in small steps [approximately 0.04 bar (0.5 psig)] by changing the process pressure to the controller or by changing the controller set point. After each change in process pressure or set point, the controller output pressure should quickly change and then stabilize at the new value.
10. Continue to change the controller output pressure in 0.04 bar (0.5 psi) steps and check the output pressure after each step to make sure it stabilizes. At some point, the controller output will start to ramp upward to supply pressure with no further change to the controller input or set point. Record the controller output pressure where this ramping action begins because this is the point at which the differential relief valve has relieved.
11. To obtain the differential relief valve differential setting, calculate the difference between the original controller output pressure in step 7 and the controller output pressure recorded in step 10.
12. If the differential pressure calculated in step 11 is incorrect for the application, adjust the differential pressure by turning the differential relief valve adjustment screw shown in figure 4-3. Turn the screw clockwise to decrease the differential pressure or counterclockwise to increase the differential pressure. The differential relief valve is set at the factory to relieve at approximately 0.4 bar (5 psi) differential pressure.
13. Repeat steps 7 through 12 until the required differential pressure is obtained.

4195KA, KB, KC, and KS Controllers

Calibration for the differential relief valve to relieve on falling controller output pressure

1. Provide a means of measuring the controller output pressure by connecting the controller output to a pressure gauge (open-loop conditions must exist). Do not apply supply pressure at this time.
2. Set the reset adjustment to 0.01 minutes per repeat (wide open) and the rate adjustment (4195KC Series only) to the OFF position.
3. For a controller with manual set point, move the set point indicator to the mid-scale mark on the process scale. For a controller with remote set point, adjust the remote set point pressure until the set point indicator is at the mid-scale mark on the process scale.
4. Set the proportional band to 100 percent in either the DIRECT or REVERSE action depending on the application requirements.
5. Refer to figure 4-3 for the location of the anti-reset windup differential relief valve. For the differential relief valve to relieve on falling controller output pressure, install the valve so the arrow on the valve points up. To change the direction of the arrow, loosen the two mounting screws, pull the valve out, and reinstall the valve with the arrow pointing up. Tighten the two mounting screws.
6. Provide a regulated supply pressure to the controller. Do not exceed the normal operating pressure in table 1-6.

Note

Because of the high controller gain with the reset adjustment at 0.01 minutes per repeat, the controller output will not balance perfectly in the following step. If the controller output is stable for approximately 5 seconds, it is adequately balanced.

7. Increase the process pressure (or vacuum for a vacuum controller) to the controller until the controller output pressure balances at 0.8 bar (12 psig) for a 0.2 to 1.0 bar (3 to 15 psig) output range or 1.6 bar (24 psig) for a 0.4 to 2.0 bar (6 to 30 psig) output range.
8. Turn the reset adjustment to the CLOSED (4195KB Series) or OFF (4195KC Series) position.
9. Decrease the controller output pressure in small steps [approximately 0.04 bar (0.5 psig)] by changing the process pressure to the controller or by

changing the controller set point. After each change in controller process pressure or set point, the controller output pressure should quickly change and then stabilize at the new value.

10. Continue to change the controller output pressure in 0.04 bar (0.5 psi) steps and check the output pressure after each step to make sure it stabilizes. At some point, the controller output will start to ramp downward to 0 bar (0 psig) with no further change to the controller input or set point. Record the controller output pressure where this ramping action begins because this is the point at which the differential relief valve has relieved.

11. To obtain the differential relief valve differential setting, calculate the difference between the original controller output pressure in step 7 and the controller output pressure recorded in step 10.

12. If the differential pressure calculated in step 11 is incorrect for the application, adjust the differential pressure by turning the differential relief valve adjustment screw, shown in figure 4-3. Turn the screw clockwise to decrease the differential pressure or counterclockwise to increase the differential pressure. The differential relief valve is set at the factory to relieve at approximately 0.4 bar (5 psi) differential pressure.

13. Repeat steps 7 through 12 until the required differential pressure is obtained.

Principle of Operation for 4195KB and KC Series Controllers

Overall Operation

Refer to the schematic diagram in figure 4-5 for the 4195KB Series controllers, or to the schematic diagram in figure 4-6 for the 4195KC Series controllers.

The input element is connected to the process pointer and to the flapper by connecting links. As the process pressure increases (in a direct-acting controller), the flapper moves toward the nozzle, restricting flow through the nozzle and increasing nozzle pressure. When this occurs, relay action increases the output pressure (delivery) of the controller. Output pressure is fed back to the proportional bellows and to the reset bellows. The action of the proportional bellows quickly counteracts the flapper movement that resulted from the process pressure change and backs the flapper away from the nozzle.

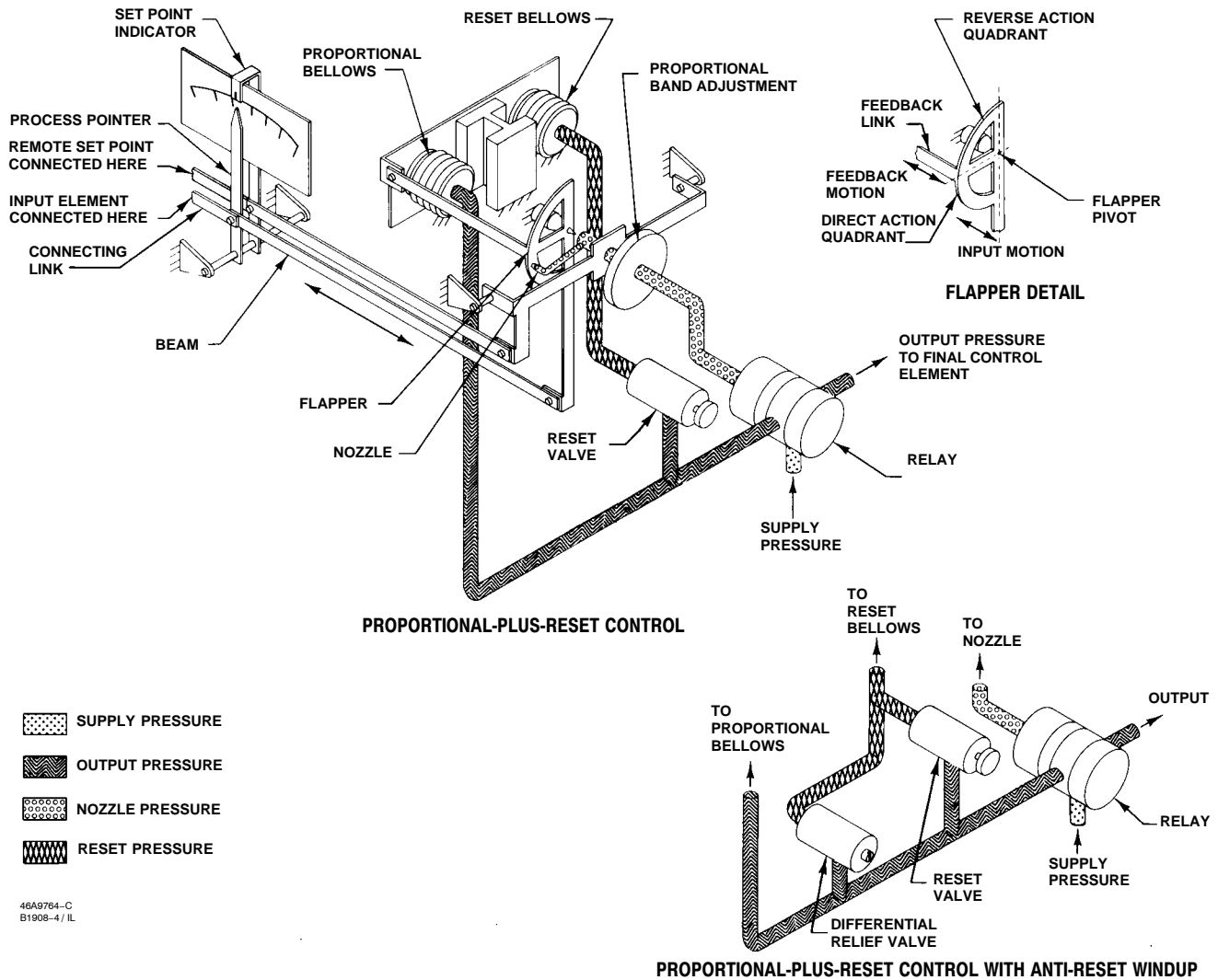

Figure 4-5. 4195KB Series Controller Schematic

Pressure in the reset bellows opposes the action of the proportional bellows and slowly moves the flapper closer to the nozzle. The result of this interaction is that, when the process pressure changes, proportional action temporarily reduces the gain of the controller for improved stability. The process pressure then slowly returns to set point, as pressure in both bellows equalizes via the reset action.

Moving the set point indicator changes the distance between the nozzle and flapper as does a change in process pressure, except that when the set point is changed, the nozzle moves with respect to the flapper.

The proportional band adjustment positions the nozzle on the flapper. Increasing (widening) the proportional band moves the nozzle to a position on the flapper where less input and more feedback motion occurs, which decreases the gain of the controller. Decreasing (narrowing) the proportional band moves the nozzle toward a position where more input and less feedback motion occurs, which increases the gain. The controller action is changed from direct to reverse by turning the proportional band adjustment to position the nozzle on the flapper quadrant to a point where the direction of the flapper motion versus input motion is reversed as shown in the flapper detail of figure 4-5 or 4-6. With the controller in the reverse-acting mode, an increase in process pressure causes a decrease in output pressure.

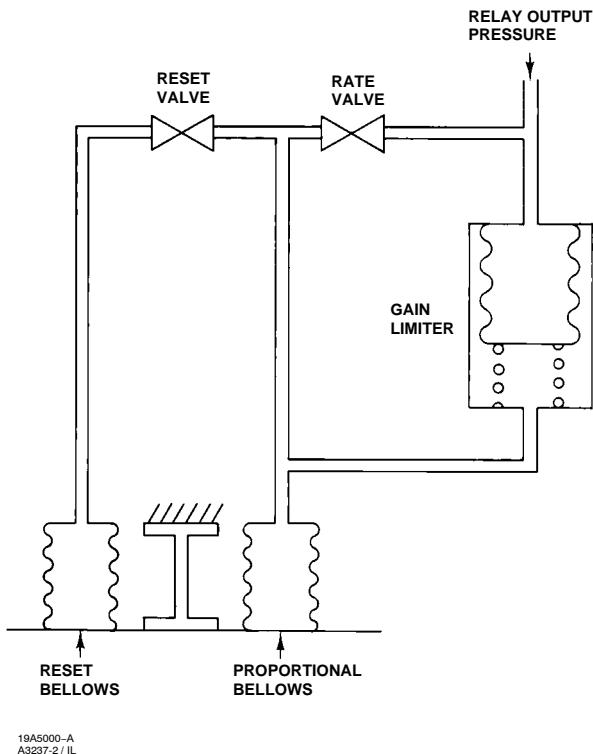

Figure 4-7. Reset-Rate Schematic

Anti-Reset Windup (suffix letter F)

Operation

Anti-reset windup is available on all 4195KB and KC Series controllers and is designated by the letter F in the type number. The differential relief valve operates when the difference between the proportional bellows pressure and the reset bellows pressure reaches a predetermined value. Anti-reset windup reduces overshoot of the process pressure that can result from a large or prolonged deviation from set point.

Remote Set Point (suffix letter M)

Operation

The capability to adjust the controller set point from a remote location is available with all 4195KB and KC Series controllers. This option is designated by the letter M in the type number.

A control pressure is applied to the capsular element within the remote set point assembly. The expansion

and contraction of the capsule moves the set point indicator via connecting linkage. Increasing the control pressure to the capsule increases the set point setting and decreasing the control pressure reduces the set point setting.

Auto/Manual Station (suffix letter E) Operation

A controller with the auto/manual station (designated by the suffix letter E in the type number) has piping on the output side of the relay as shown in figure 4-8. Supply pressure to the relay is also applied to the manual loader. The manual loader, functioning as a regulator, applies pressure to one side of the plastic tube and to the auto/manual switch. Output pressure from the relay registers on the other side of the plastic tube as well as in the auto/manual switch.

When the auto/manual switch is in the MANUAL position, the manual loader output is channeled through the auto/manual switch and becomes the controller output. When the auto/manual switch is in the AUTO position, the relay output is channeled through the switch to become the controller output.

Before the auto/manual switch is operated, the relay output must equal the manual loader output to avoid bumping the process. Adjusting the set point varies the pressure on the left-hand side of the plastic tube. Adjusting the manual loader knob varies the pressure on the right-hand side. When the pressures are equal, the metal ball is centered in the tube and it is held in place by a small magnet. A pressure imbalance forces the ball to one end of the tube where it forms a seal, blocking air flow through the tube.

External Feedback Operation

External feedback is available for all 4195KB Series controllers. Controllers with this option have an external connection on the bottom of the controller case as shown in figure 2-5. This connection breaks the positive feedback (reset) loop inside the controller and brings it outside as shown in figure 4-9. The connection allows the positive feedback loops of two controllers (primary and secondary) to be tied together when the controllers are used in an override application. When connected, the secondary controller tracks the primary controller, minimizing reset windup.

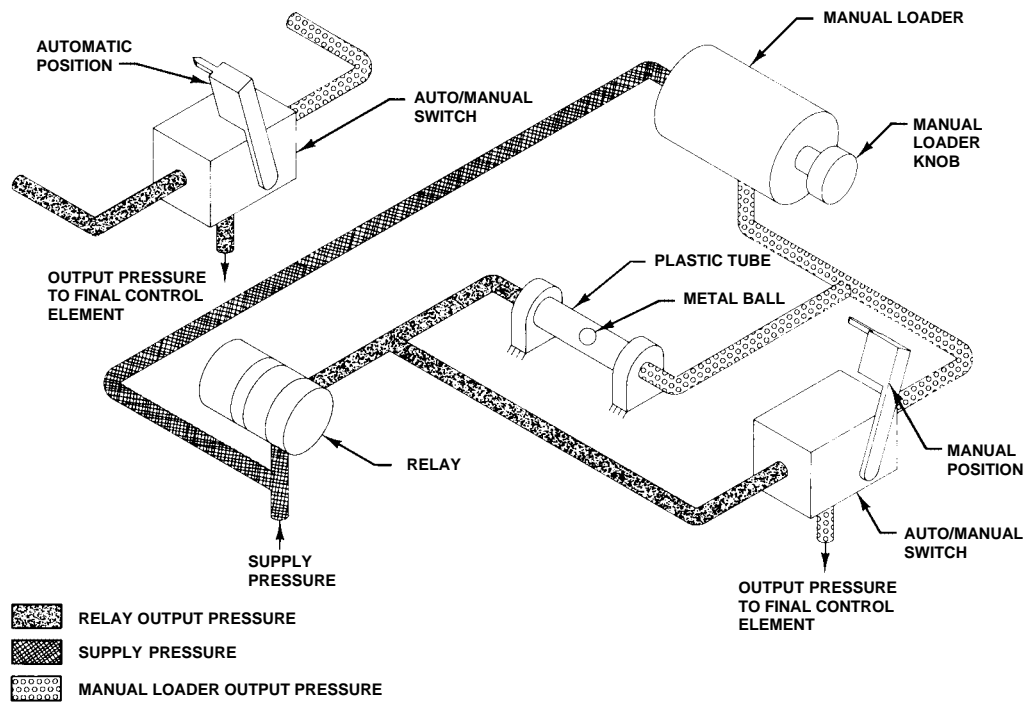

48A5230-A
A2999-1 / IL

Figure 4-8. 4195KB and KC Series Auto/Manual Station Schematic

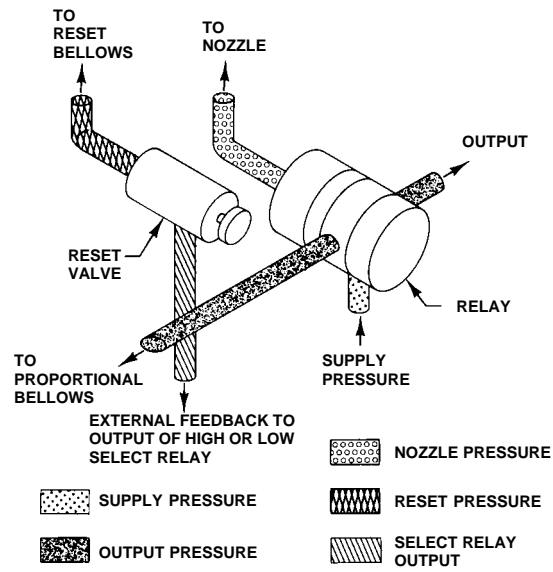

47A0975-A
A3342-1 / IL

Figure 4-9. Schematic of External Feedback Option

Section 5 4195KS Series Differential Gap Controllers

Operating Information

This section includes descriptions of adjustments and procedures for prestartup and startup. Location of adjustments is shown in figures 5-1 and 5-2. To better understand the adjustments and overall operation of the controller, refer to the Principle of Operation section and the schematic diagrams, figures 5-4 and 5-5.

Note

Some of the following procedures require that the proportional band knob be adjusted to between **DIRECT** and **REVERSE**. If this is done, it will be necessary to set the proportional band knob to 400 (direct or reverse action) before replacing the proportional band indicator cover.

Adjustments for 4195KS Series Controllers

Manual Set Point

The set point adjustment adjusts the upper or lower switching point, depending on controller action. To adjust the set point, open the controller cover, and move the set point adjustment until the pointer indicates the desired value of pressure on the process pressure scale. Move the adjustment to the right to increase the set point, and to the left to decrease it. Adjusting the set point does not affect the differential gap setting.

Remote Set Point (Option M)

CAUTION

Do not move the set point manually on controllers with remote set point. Doing so could damage the controller.

If the controller is equipped with remote set point option, vary the remote set point pressure to change

the set point. Increase the pressure to increase the set point, and decrease the pressure to decrease the set point.

Proportional Band (Differential Gap)

The proportional band knob adjusts width of the gap between switching points. Rotate the knob until the desired value is opposite the line on the proportional band indicator cover.

Changing Controller Action

Controller action can be switched from direct to reverse or vice versa by loosening the screws on the proportional band indicator cover and moving the cover out so the proportional band knob can be rotated to the desired action. The white portion of the adjustment enables direct controller action; the black portion enables reverse controller action.

Auto/Manual Switching (Option E)

Refer to figure 5-5 if the controller has the auto/manual option. Two balance methods are available to equalize the manual output with the controller pressure. To switch from automatic to manual mode, carefully adjust the loader knob until the metal ball inside the plastic tube moves into the switching zone. Then move the automatic/manual switch to **MANUAL**. Turn the loader knob clockwise to increase the controller output or counter clockwise to decrease it. To switch from manual to automatic mode, adjust the set point manually or with remote set point pressure to move the ball into the switching zone. Turn the switch to **AUTOMATIC**, and adjust the set point manually or with the remote set point pressure to control the output.

When the automatic/manual switch is in **AUTOMATIC**, adjusting the loader knob has no effect on the controller output. When the automatic/manual switch is in **MANUAL**, changing the set point adjustment has no effect on the controller output.

Note

Switching the controller between automatic and manual, or manual and automatic mode, without balancing the outputs, can disturb the process and cause controller cycling.

4195KA, KB, KC, and KS Controllers

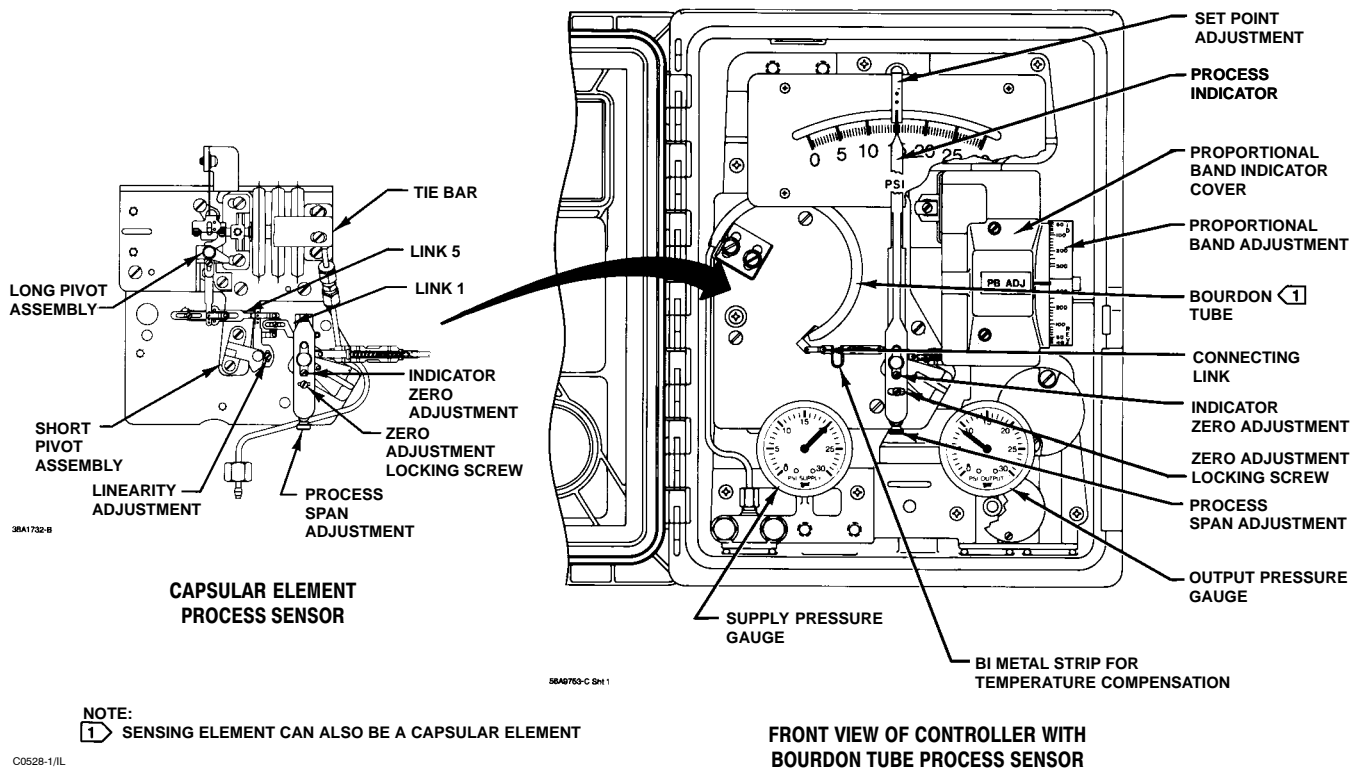

Figure 5-1. 4195KS Series Controller Parts and Adjustments Locations

Prestartup Checks for 4195KS Series Controllers

When performing the checks, open loop conditions must exist. Refer to figure 5-1 for location of adjustments.

Note

If the controller has the auto/manual option (option E), be sure the controller is in the automatic mode prior to performing prestartup checks.

1. Connect supply pressure to the supply pressure regulator, and be sure it is delivering the proper supply pressure to the controller. Provide a means of measuring the controller output pressure.
2. For controllers with remote set point (option M), connect regulated pressure of 0.2 to 1.0 bar (3 to 15 psig) or 0.4 to 2.1 bar (6 to 30 psig) to the remote set point connection at the top of the controller case.
3. Loosen two screws (key 6), lift off the proportional band cover (key 36), and set the

proportional band knob between DIRECT and REVERSE.

4. The process indicator should indicate the process pressure. For example, with the process pressure at 50 percent of the input span, the process pointer should be 50 percent (+/-1 percent) of its span. Slight adjustment of the indicator zero screw may be necessary. See figure 5-1 for zero adjustment and locking screw location.

5. If desired, the accuracy can be verified at other points on the scale. If the indicator appears to be out of calibration, refer to the process zero and span adjustment portion of the calibration procedure.

6. Install the proportional band cover and install two screws (key 6).

Startup for 4195KS Series Controllers

It is recommended that the controller switching points be set as described in the calibration procedures.

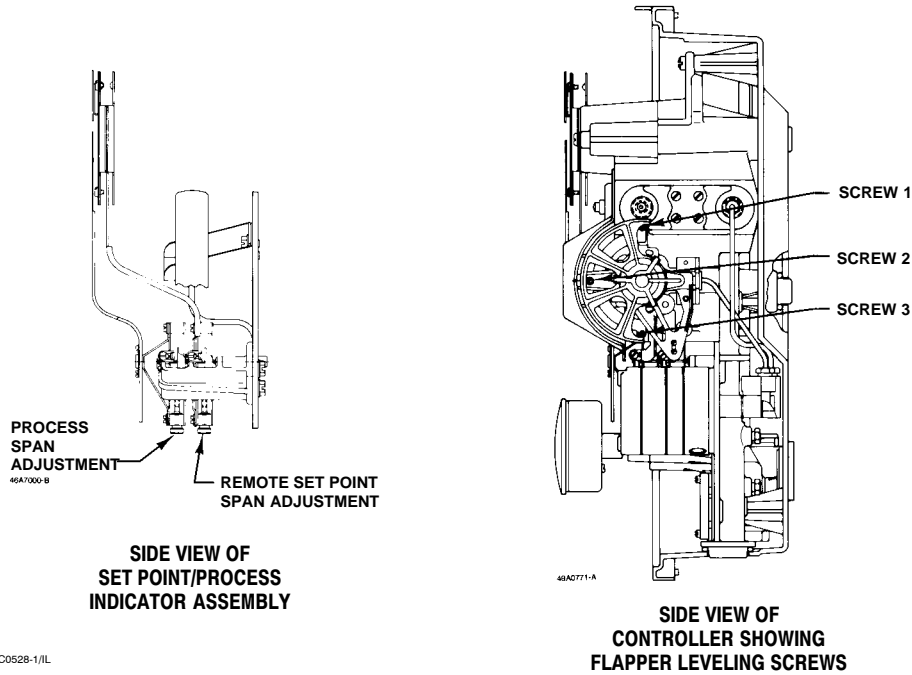

Figure 5-1. 4195KS Series Controller Parts and Adjustments Locations (continued)

If they are used, slowly open the upstream and downstream manual control valves in the pipeline and close the manual bypass valve.

automatic mode prior to performing the calibration procedures.

Calibration of 4195KS Series Controllers

Process Zero and Span Adjustment

Note

Some of the following procedures require that the proportional band knob be adjusted to between DIRECT and REVERSE. If this is done, it will be necessary to set the proportional band knob to 400 (direct or reverse action) before replacing the proportional band indicator cover.

If the prestartup checks revealed faulty adjustment of the process indicator, perform the calibration procedures. These procedures are valid for either shop or field calibration, provided that open process loop conditions exist.

Note

If the controller has the auto/manual option, be sure the controller is in the

Note

Any adjustment of the pointer span adjustment screw will require readjustment of the pointer zero adjustment screw.

1. Refer to figure 5-1 for location of adjustments.
2. Remove the two screws (key 6) and lift off the proportional band indicator cover (key 36).
3. Set the proportional band between DIRECT and REVERSE.
4. Adjust the process pressure to the low limit of the input range.
5. Adjust the process pointer to the lowest limit of the input scale by loosening the zero adjustment locking screw and turning the zero adjustment screw.
6. Adjust the process pressure to the upper limit of the input span. Note whether the pointer indication is above or below the upper limit of the process scale.

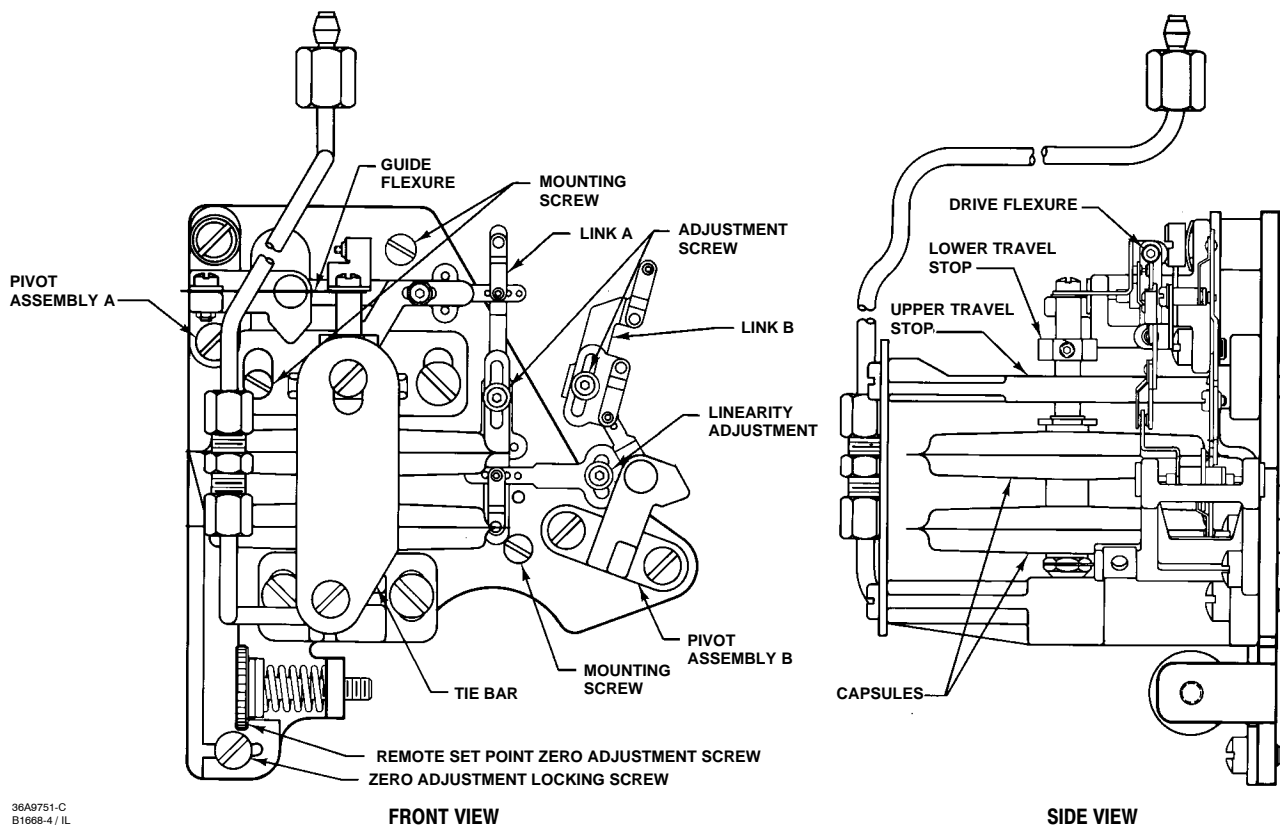

Figure 5-2. 4195KS Series Controller Parts and Adjustments Locations (Remote Set Point Option)

7. Adjust the span screw as follows: Clockwise to increase span for a low indication; counterclockwise to decrease span for a high indication. Adjust the span screw to correct one-half the error.
8. Repeat steps 4 through 7 until the error is eliminated.
9. Install the proportional band indicator cover (key 36), and tighten the two screws (key 6).

Remote Set Point Zero and Span Adjustment (Option M)

Note

Any adjustment of the pointer span adjustment screw will require readjustment of the pointer zero adjustment screw.

1. Refer to figures 5-1 and 5-2 for location of adjustments.
2. Remove the two screws (key 6) and lift off the proportional band indicator cover (key 36).

3. Set the proportional band between DIRECT and REVERSE.
4. Adjust the process pressure to the low limit of the input range.
5. Adjust the process pointer to the lowest limit of the input scale by loosening the zero adjustment locking screw and turning the zero adjustment screw.
6. Adjust the process pressure to the upper limit of the input span. Note whether the pointer indication is above or below the upper limit of the process scale.
7. Adjust the span screw as follows: Clockwise to increase span for a low indication; counterclockwise to decrease span for a high indication. Adjust the span screw to correct one-half the error.
8. Repeat steps 4 through 7 until the error is eliminated.
9. Install the proportional band indicator cover (key 36), and tighten the two screws (key 6).

Setting Switching Points

Direct-Acting Controllers

The controller output signal will switch from zero pressure to full supply pressure when increasing process pressure passes the upper switching point.

The controller output signal will not return to zero pressure until decreasing process pressure passes the lower switching point. When making adjustments as described in the following steps, keep in mind that:

- Changing the set point adjustment will move both switching points equally in the direction of adjustment.
- Changing the proportional band adjustment will widen or narrow the differential gap between the two switching points by moving the position of the lower switching point.

Figure 5-3 shows the relationship between the percent of sensor range between switching points and the proportional band setting on the controller. The following example illustrates how to use figure 5-3.

Example: The sensing element has a range of 30 psi. The lower switching point is to be set at 10 psi and the upper switching point is to be set at 25 psi.

Proceed as follows:

- Divide the differential gap (the difference between the upper and lower switching points) by the sensing element range. Multiply the result by 100 as shown in the following equation.

$$\frac{\text{Differential Gap}}{\text{Sensing Element Range}} \times 100 = \frac{15 \text{ psi}}{30 \text{ psi}} \times 100 = 50$$

- Locate the 50 percent line on figure 5-3. Move along this line until you intersect the curve. Read the proportional band setting on the left hand axis. For this example, the setting is approximately 35 percent.

1. Using the curve in figure 5-3, determine the correct proportional band setting for the desired gap (expressed as a percent of the input span) between the switching points.
2. Set the proportional band knob to the desired setting determined in step 1.

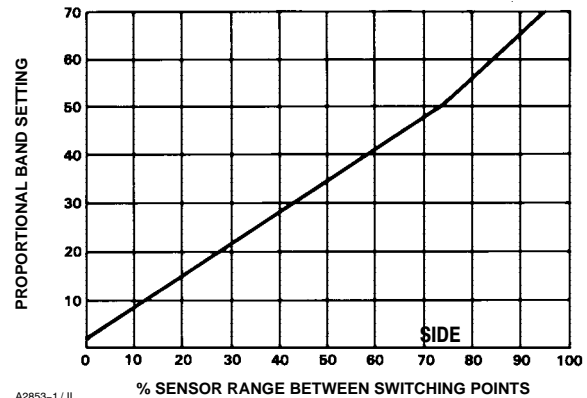

Figure 5-3. Curve for Determining Proportional Band Setting

3. Adjust the set point to the desired upper switching point.
4. Increase the process pressure until the controller output signal switches from zero pressure to full supply pressure.
5. Decrease the process pressure to the desired switching point at which the controller output signal switches from full supply pressure to zero pressure.
6. Narrow or widen the proportional band slowly until the output signal switches from full supply pressure to zero pressure.
7. Repeat steps 4 through 6 until the controller output switches at the desired points.
8. Observe the process pointer when the output switches at the upper switching point. The process pointer indication should be within ± 2 percent of the set point indication.

Reverse-Acting Controllers

The controller output signal will switch from zero pressure to full supply pressure when decreasing process pressure passes the lower switching point.

The controller output signal will not return to zero pressure until increasing process pressure passes the upper switching point. When making adjustments as described in the following steps, keep in mind that:

- Changing the set point adjustment will move both switching points equally in the direction of adjustment.
- Changing the proportional band adjustment will widen or narrow the differential gap between the two switching points by moving the position of the lower switching point.

4195KA, KB, KC, and KS Controllers

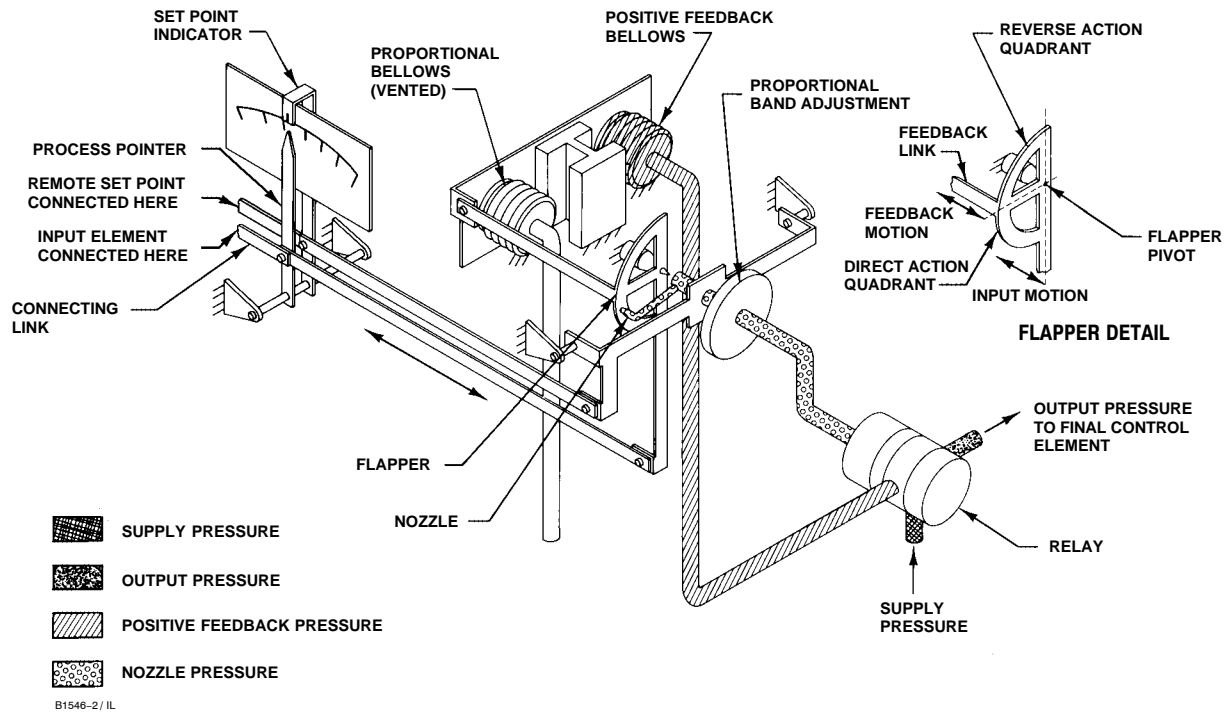

Figure 5-4. 4195KS Series Controller Schematic

Figure 5-3 shows the relationship between the percent of sensor range between switching points and the proportional band setting on the controller. The following example illustrates how to use figure 5-3.

Example: The sensing element has a range of 30 psi. The lower switching point is to be set at 10 psi and the upper switching point is to be set at 25 psi.

Proceed as follows:

- Divide the differential gap (the difference between the upper and lower switching points) by the sensing element range. Multiply the result by 100 as shown in the following equation.
- Locate the 50 percent line on figure 5-3. Move along this line until you intersect the curve. Read the proportional band setting on the left hand axis. For this example, the setting is approximately 35 percent.

$$\frac{\text{Differential Gap}}{\text{Sensing Element Range}} \times 100 = \frac{15 \text{ psi}}{30 \text{ psi}} \times 100 = 50$$

1. Using the curve in figure 5-3, determine the correct proportional band setting for the desired gap (expressed as a percent of the maximum input element span) between the switching points.
2. Set the proportional band knob to the desired setting determined in step 1.
3. Adjust the set point to the desired lower switching point.
4. Decrease the process pressure until the controller output signal switches from zero pressure to full supply pressure.
5. Increase the process pressure to the desired switching point at which the controller output signal switches from full supply pressure to zero pressure.
6. Narrow or widen the proportional band slowly until the output signal switches from full supply pressure to zero pressure.
7. Repeat steps 4 through 6 until the controller output switches at the desired points.
8. Observe the process pointer when the output switches at the upper switching point. The process pointer indication should be within +/-2 percent of the set point indication.

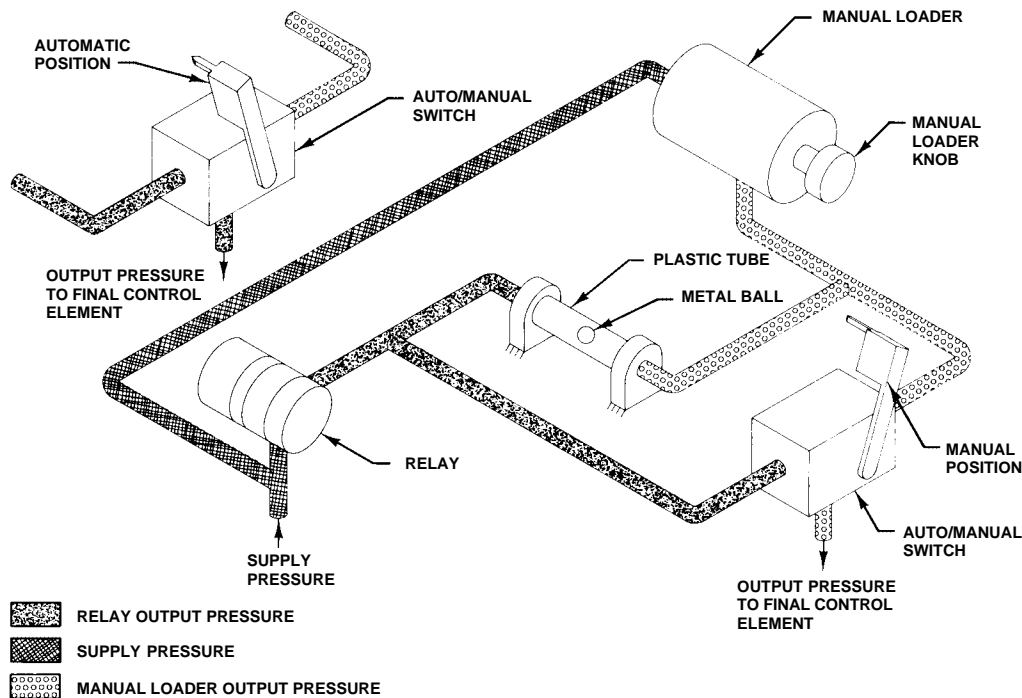

48A5230-A
A2899-1 / IL

Figure 5-5. 4195KS Series Auto/Manual Schematic

Principle of Operation

Overall Operation

Refer to the schematic diagram in figure 5-4.

The input element is connected to the process pointer and to the flapper by connecting links. As the process pressure increases (in a direct-acting controller). This movement restricts the flow through the nozzle and increases nozzle pressure. When this occurs, relay action increases the output pressure (delivery) of the controller. Output pressure is fed back to the positive feedback bellows. The action of this bellows is a positive feedback action that moves the flapper closer to the nozzle, increasing nozzle pressure, which in turn, increases the relay output. Output pressure to the final control element switches to full supply pressure.

As the process pressure decreases, approaching the lower switching point, the flapper moves away from the nozzle (in a direct-acting controller) reducing nozzle pressure. Through relay action, pressure to the positive feedback bellows is

reduced, moving the flapper further away from the nozzle, and further reducing nozzle pressure. Output pressure to the final control element switches to zero.

The set point adjustment changes the proximity of the nozzle and flapper as does a change in process pressure except that, when the set point is changed, the nozzle moves with respect to the flapper. The set point adjustment moves both the upper and lower switching points.

The proportional band knob positions the nozzle on the flapper. Increasing (widening) the proportional band moves the nozzle away from the input connection. When the proportional band adjustment moves the nozzle across the feedback connection, the controller action changes between direct and reverse. On a direct-acting controller, changing the proportional band adjustment will widen or narrow the differential gap between the two switching points. This is accomplished by moving the position of the lower switching point. On a reverse-acting controller, changing the proportional band adjustment will widen or narrow the differential gap

4195KA, KB, KC, and KS Controllers

between the two switching points by moving the position of the upper switching point.

Remote Set Point (Option M)

The capability to adjust the controller set point from a remote location is available with all 4195KS Series controllers. This option is designated by the letter M in the type number.

Auto/Manual Option

Controllers with the auto/manual option (designated by the letter E in the type number) have piping on the output side of the relay as shown in figure 5-5. Supply pressure to the relay is also applied to the manual loader. The manual loader, functioning as a regulator, applies pressure to one side of the plastic

tube and to the auto/manual switch. Output pressure from the relay registers on the other side of the plastic tube as well as in the auto/manual switch.

When the auto/manual switch is in the MANUAL position, the manual loader output is channeled through the auto/manual switch and becomes the output of the controller. When the auto/manual switch is in the AUTO position, the relay output is channeled through the switch to become the output of the controller.

Before the auto/manual switch is operated, the relay output must equal the manual loader output to avoid bumping the process. Adjusting the set point varies the pressure on the left-hand side of the plastic tube. Adjusting the manual loader knob varies the pressure on the right-hand side. When the pressures are equal, the metal ball is centered in the tube. Pressure imbalance forces the ball to one end of the tube where it forms a seal, blocking air flow through the tube.

Section 6 Maintenance

Controller parts are subject to normal wear and must be inspected and replaced as necessary. The frequency of inspection and parts replacement depends upon the severity of the service conditions. When inspection or repairs are required, disassemble only those parts necessary to accomplish the job.

Inspection and Maintenance



WARNING

The following maintenance procedures require taking the controller out of service. To avoid personal injury and property damage caused by uncontrolled process pressure, observe the following before performing any maintenance procedures:

Before performing any maintenance operations:

- Always wear protective clothing, gloves, and eyewear.
- Provide some temporary means of control for the process before taking the controller out of service.
- Shut off the supply pressure to the controller.
- Personal injury or property damage may result from fire or explosion if natural gas is used as the supply pressure medium and preventative measures are not taken. Preventative measures may include: Remote venting of the unit, Re-evaluation the hazardous area classification, ensuring adequate ventilation, and the removal of any ignition sources. For information on remote venting of this controller, refer to page 2-5.
- Disconnect any operating lines providing supply air pressure, a process input signal, or other pressure source to the controller.
- Check with your process or safety engineer for any additional

measures that must be taken to protect against process media.

Note

Unless otherwise noted, key numbers refer to figures 7-1 through 7-7. Figures 3-1 and 3-3 show adjustment locations for 4195KA Series controllers, figures 4-1 and 4-3 show adjustment locations for 4195KB and KC Series controllers, and figures 5-1 and 5-2 show adjustment locations for 4195KS Series controllers. For maintenance on the indicator assembly, refer to figures 7-2, 7-3 and 7-4.

Select the appropriate maintenance procedure and perform the numbered steps. Each procedure requires that the supply pressure be shut off before beginning maintenance.

The maintenance procedures section describes part replacement common to 4195KA, KB, KC, and KS Series controllers. After completing the maintenance procedures, perform the appropriate calibration procedures. Unless otherwise noted, calibration procedures for the 4195KA Series controller are in Section 3, calibration procedures for the 4195KB and KC Series controller are in Section 4, and calibration procedures for the 4195KS Series controller are in Section 5. If difficulty is encountered performing the calibration procedures in Section 3, 4, or 5 refer to the calibration procedures in this section.

Troubleshooting

As an aid to troubleshooting, table 6-1 lists some common operating faults, their probable cause, and suggests procedures for correcting the faults.

Replacing Common Controller Parts



WARNING

To avoid personal injury or property damage caused by the uncontrolled release of pressure, be sure any trapped process pressure is properly vented from the controller. Vent any supply pressure from the controller before disassembly.

4195KA, KB, KC, and KS Controllers

Table 6-1. Troubleshooting Chart

Fault	Possible Cause	Check	Correction
<p>1. Process wanders or cycles about set point</p>	<p>1.1 Proportional band and reset settings</p> <p>1.2 Supply pressure varying</p> <p>1.3 Process pointer rubbing on cover or scale</p> <p>1.4 Input element failure</p> <p>1.5 Linkage failure</p> <p>1.6 Relay malfunction</p> <p>1.7 Anti-reset windup differential relief valve set too low (suffix letter F only)</p>	<p>1.1 Refer to the startup procedures for controller settings</p> <p>1.2 Monitor the supply pressure with an external gauge. Ensure that it is set correctly and does not fluctuate. Note the number of instruments being supplied by the regulator</p> <p>1.3 Note if the pointer is bent</p> <p>1.4 Inspect the element for loose screws and damaged flexures, links or pivots. Using a soap solution, check the sensing element for leaks</p> <p>1.5 Check for links that are bent or not connected properly, flexures bent or broken, pivots broken</p> <p>1.6 By changing the process set point and observing the output verify that the output will change at about the same rate in both directions.</p> <p>1.7 The minimum relief valve setting is dependent on the loop dynamics and the controller settings. If under normal load changes, the relief valve opens, instability can occur. Check by observing the controller reaction to a set point or load change under closed loop conditions</p>	<p>1.1 If stable control cannot be attained, and all other elements of the loop are functionally correct, examine other possible causes related to the controller</p> <p>1.2 Correct as necessary. One regulator per instrument is recommended</p> <p>1.3 Bend pointer to provide clearance</p> <p>1.4 Repair or replace parts as necessary</p> <p>1.5 Replace or repair as necessary</p> <p>1.6 If the output changes quickly in one direction and sluggishly in the other, replace the relay</p> <p>1.7 If the differential relief valve appears to be set too low, refer to the section of this instruction manual that covers the anti-reset windup option</p>
<p>2. Controlling off set point as reflected by process and set point indicators.</p> <p>Note: Some offset is inherent with proportional-only controllers (4195KA Series). The amount of offset is a function of the proportional band setting</p>	<p>2.1 Supply pressure not set correctly</p> <p>2.2 Flapper not aligned</p> <p>2.3 Leak in input element/tubing assembly</p> <p>2.4 Indicators out of calibration</p> <p>2.5 Linkage not connected correctly</p> <p>2.6 Leak in feedback system</p>	<p>2.1 Check with an external source</p> <p>2.2 Refer to the flapper alignment procedure</p> <p>2.3 Using soap solution, check the input element and tubing for leaks</p> <p>2.4 Refer to the process indicator (and remote set if applicable) zero and span calibration procedures in this manual</p> <p>2.5 Inspect for loose screws and damaged flexures, links or pivots</p> <p>2.6 Open the reset valve to 0.1 minute/repeat. Adjust output pressure to 1.4 bar (20 psig). Using soap solution, check for leaks in the proportional and reset bellows in the tubing that connects these bellows</p>	<p>2.1 Reset the supply pressure if necessary. If the condition occurs again, the regulator should be rebuilt or replaced</p> <p>2.2 Align the flapper as necessary</p> <p>2.3 Repair or replace parts as necessary</p> <p>2.4 Adjust as necessary</p> <p>2.5 Repair or replace parts as necessary</p> <p>2.6 Repair as necessary</p>

(continued)

Table 6-1. Troubleshooting Chart (continued)

Fault	Possible Cause	Check	Correction
2. Controlling off set point as reflected by process and set point indicators. Note: Some offset is inherent with proportional-only controllers (4195KA Series). The amount of offset is a function of the proportional band setting	2.7 Reset valve leaks	2.7 Hold the input constant and adjust the output to 1.0 bar (15 psig) for a 0.2 to 1.0 bar (3 to 15 psig) output or 2.0 bar (30 psig) for a 0.4 to 2.0 bar (6 to 30 psig) output. Close the reset valve. If the controller output varies as the reset valve is closed and no leaks were found in the rest of the feedback system (Step 2.6), the reset valve is leaking	2.7 Replace the reset valve (4195KB Series) or the rate/reset valve (4195KC Series)
	2.8 Leak in remote set point system	2.8 Adjust remote set point pressure to 1.0 bar (15 psig). Using soap solution, check for leaks in the remote set point and tubing assembly	2.8 Repair or replace parts as necessary
	2.9 Input element overpressured	2.9 Check for zero shift	2.9 Replace input element and adjust travel stops of applicable
3. Controlling off set point but not reflected by process and set point indicators	3.1 Controller is out of calibration	3.1 Refer to the process indicator, remote set point (if applicable), and flapper alignment procedures	3.1 Adjust as necessary
4. No reset action (4195KB and 4195KC Series)	4.1 Reset valve is plugged	4.1 Turn the reset valve through its range several times to remove any restrictions	4.1 If reset action returns, no further action is necessary. If not, replace the reset valve (4195KB Series) or rate/reset valve (4195KC Series)
	4.2 Reset pressure leak	4.2 Adjust the output to 1.0 bar (15 psig) for a 0.2 to 1.0 bar (3 to 15 psig) output or 2.0 bar (30 psig) for a 0.4 to 2.0 bar (6 to 30 psig) output. Close the reset valve. If the output varies and no leaks were found in the rest of the feedback system (see Step 2.6), the reset valve is leaking	4.2 Replace the reset valve (4195KB Series) or the rate/reset valve (4195KC Series)
	4.3 Tubing leak	4.3 With reset valve positioned at .01 minute/repeat put 1.0 bar (15 psig) to the output port. Using soap solution, check for leaks in the reset bellows and attached tubing assembly	4.3 Repair or replace parts as necessary
5. Abnormal control point shift when proportional band is changed Note: Control point shift is inherent when changing proportional band in proportional-only controllers (4195KA Series).	5.1 Flapper is out of alignment	5.1 Refer to flapper alignment procedure	5.1 Align flapper as necessary
	5.2 Flapper is dirty or pitted	5.2 Inspect the flapper	5.2 Clean, or replace flapper as necessary
6. Controller will not attain full output range	6.1 Output pressure gauge not functioning	6.1 Measure the output with an external pressure gauge	6.1 Replace the gauge if it is defective
	6.2 Supply pressure not correct	6.2 Check with an external source	6.2 Repair or replace the supply pressure regulator, if necessary. Replace the supply pressure gauge if necessary
	6.3 Proportional band setting too wide (4195KA Series only)	6.3 Adjust proportional band setting to 10. Manually cap the nozzle. Output should increase	6.3 Use a narrower proportional band setting
	6.4 Input element or linkage failure	6.4 Inspect the element for alignment and loose screws	6.4 Repair or replace parts as necessary

(continued)

Table 6-1. Troubleshooting Chart (continued)

Fault	Possible Cause	Check	Correction
6. Controller will not attain full output range (continued)	6.5 Nozzle pressure leak	6.5 Check for nozzle tubing leaks with a water bottle and soap solution with the nozzle capped by the flapper. Press the nozzle cap (key 23) gently to ensure the nozzle assembly is sealing. Ensure the relay nozzle tubing nut (key 18) is tight and the manifold screws (keys 34 and 131) are tight	6.5 Tighten the relay nozzle tubing nut (key 18). Tighten the manifold screws (keys 34 and 131). Replace the nozzle assembly (key 21), O-ring (key 24), or set point beam assembly (key 23) as necessary if leaking
	6.6 Leak in nozzle pressure tubing	6.6 Using soap solution, check for leaks in the nozzle tubing assembly	6.6 Replace faulty parts as necessary. Clean out the relay primary orifice with the cleanout wire attached to the relay to ensure the orifice is not clogged
	6.7 Relay malfunction	6.7 Manually push the flapper away from the nozzle. The output pressure should be zero. Cap the nozzle. The output should increase rapidly to within 35 mbar (0.5 psig) of the supply pressure	6.7 If the output does not change as described, remove the relay. Replace the O-rings if necessary. Replace relay if necessary
7. Controller remains at full output	7.1 Supply pressure too high	7.1 Check with an external pressure gauge	7.1 Supply pressure regulator or gauge may have to be replaced
	7.2 Output gauge not functioning	7.2 Reduce supply pressure to 0 bar (0 psig) to see if output gauge responds	7.2 If output gauge does not respond, replace it
	7.3 Sensor or linkage failure	7.3 Vary the process pressure and observe the flapper for movement. Inspect the sensor and linkage for damage	7.3 Repair or replace parts as necessary
	7.4 Flapper mis-alignment	7.4 Vary the process pressure and verify that the nozzle can be uncapped by the flapper	7.4 Perform flapper alignment procedures
	7.5 Relay failure or restriction in nozzle passage	7.5 Loosen the relay nozzle tubing nut (key 18) with full supply pressure	7.5 If the output pressure remains at the supply pressure, replace the relay. If the output pressure moves to 0 bar (0 psig), clean or replace nozzle or nozzle tubing.
8. Controller remains at zero output	8.1 Gauge not functioning	8.1 Verify that the supply pressure is at its correct value and that the controller output is zero	8.1 Replace gauges as necessary
	8.2 Sensor or linkage failure	8.2 Vary the process pressure and observe the flapper for movement. Inspect the sensor and linkage for damage	8.2 Repair or replace parts as necessary
	8.3 Flapper misalignment	8.3 Vary the process pressure and verify that the nozzle can be capped by the flapper	8.3 Perform flapper alignment procedures
	8.4 Relay malfunction	8.4 Check for air at the nozzle. Cap the nozzle and see if the controller output increases to within 0.03 bar (0.5 psig) of supply pressure	8.4 Clean out the relay primary orifice with the cleanout wire attached to the relay to ensure the orifice is not clogged. If the problem persists, replace the relay
	8.5 Nozzle pressure leak	8.5 Check for nozzle tubing leaks with a water bottle and soap solution with the nozzle capped by the flapper. Press the nozzle cap (key 23) gently to ensure the nozzle assembly is sealing. Ensure the relay nozzle tubing nut (key 18) is tight and the manifold screws (keys 34 and 131) are tight	8.5 Tighten the relay nozzle tubing nut (key 18). Tighten the manifold screws (keys 34 and 131). Replace the nozzle assembly (key 21), O-ring (key 24), or set point beam assembly (key 23) as necessary if leaking



W3440 / IL

DEFLECT LOWER PORTION OF THE SLOT



W3492 / IL

AND LIFT THE SCALE UP AND OFF

Figure 6-1. Changing the Scale

Replacing the Process Pressure Scale

WARNING

Refer to the Maintenance **WARNING** on page 6-1.

CAUTION

To prevent the pointer or set point indicator from rubbing on the cover or scale and producing an inaccurate indication, take care not to bend the process pointer or the set point indicator while performing the following procedure.

Refer to figure 6-1.

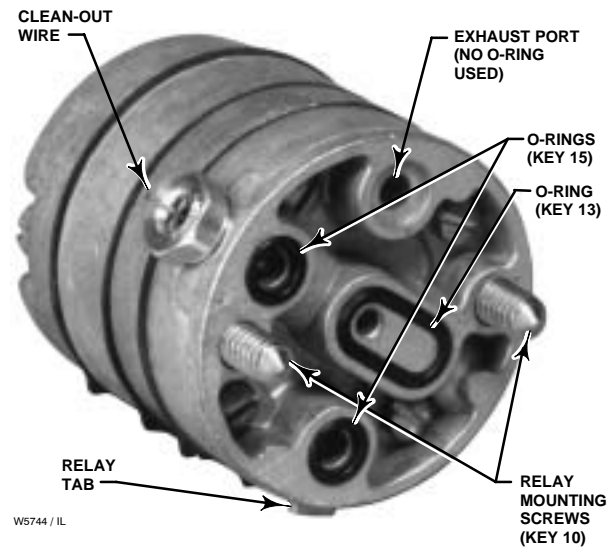

W5744 / IL

Figure 6-2. Relay Construction

1. Adjust the set point indicator (either manually or with the remote set point pressure) to the mid-scale mark on the process scale.
2. Remove the four self-tapping screws (key 37).
3. Slide the process scale (key 61) downward so that the top of the slot touches the set point indicator. Deflect the lower portion of the slot outward and carefully slide the scale up and off, clearing the set point indicator as shown in figure 6-1.
4. To install the replacement scale, deflect the lower part of the slot slightly so that the scale slides downward over the set point indicator and under the process pointer.
5. Secure the scale with the four self-tapping screws (key 37).
6. If the controller has remote set point (suffix letter M), perform the appropriate remote set point zero and span calibration procedure in Section 3, 4, or 5.
7. Perform the appropriate process indicator zero and span calibration and the flapper alignment procedures in Section 3, 4, or 5.

4195KA, KB, KC, and KS Controllers

Replacing the Relay

WARNING

Refer to the Maintenance WARNING on page 6-1.

1. Loosen the two captive screws that hold the relay (key 50) in place.
2. Tip the relay slightly toward the side of the case to clear the output pressure gauge (key 46) and lift out the relay.
3. Make sure the replacement relay has three O-rings (keys 13 and 15) installed as shown in figure 6-2. The fourth port is for exhaust and does not require an O-ring.
4. Install the replacement relay, making sure the tab on the relay, shown in figure 6-2, aligns with the tab on the frame.
5. Tighten the two screws that hold the relay in place.
6. Perform the appropriate flapper alignment procedure in Section 3, 4, or 5.

Replacing the Case and Cover

WARNING

Refer to the Maintenance WARNING on page 6-1.

CAUTION

The case and cover are an integral unit; attempting to separate them will damage the hinge. If the cover needs to be replaced, replace the case also.

1. Remove the external piping and fittings from the controller.
2. Remove the controller from its mounting to a maintenance area.
3. Remove the nine screws (key 38) from the case and cover assembly (key 1) and lift out the controller assembly. If the controller has remote set point (suffix letter M), use a screwdriver or appropriate tool to deflect the case slightly at the remote set point connection to remove the controller assembly. Inspect the O-rings around the external piping connections and replace as necessary.

4. Position the controller assembly in the replacement case and cover.
5. Start the nine mounting screws, but do not tighten.
6. Slide the controller assembly down to assure an O-ring seal at the pressure connections along the bottom of the case. Hold the controller assembly in place while tightening the nine mounting screws.
7. Remove the blow-out plug (key 72) from the original case, and install it in the replacement case.
8. Perform the controller calibration procedures and, if necessary, the appropriate remote set point calibration procedure in Section 3, 4, or 5.
9. Mount the controller as described in the Installation section.
10. Connect the external piping to the controller.

Replacing the Gauges

WARNING

Refer to the Maintenance WARNING on page 6-1.

CAUTION

Before performing this procedure, be sure the replacement gauges are the correct range so that they are not damaged by overpressure.

1. Unscrew the output pressure gauge or the supply pressure gauge (key 46) from the frame (key 3).
2. Before installing the replacement gauge, coat the threads on the gauge with a sealant such as key 311 or equivalent.
3. Screw the replacement gauge into the frame.
4. Apply the correct supply pressure and check for leaks with the nozzle capped for full output pressure.

Replacing the Supply Gauge, Proportional, Reset, Reset Valve, and Positive Feedback Tubing Assemblies

WARNING

Refer to the Maintenance **WARNING** on page 6-1.

1. Remove the controller assembly from the case by performing steps 1 through 3 of the case and cover replacement procedure.
2. Unscrew the nuts at each end of the tubing assembly. Remove the tubing assembly.
3. Install the replacement tubing assembly.
4. Set the reset adjustment to 0.01 (4195KB and KC Series) and set the rate adjustment to OFF (4195KC Series).
5. Apply the correct supply pressure and check for leaks with the nozzle capped for full output pressure. Then, remove the supply pressure.
6. Position the controller assembly in the case and start, but do not tighten the nine mounting screws. Slide the controller assembly down to assure an O-ring seal at the pressure connections along the bottom of the case. Hold the controller assembly in place while tightening the nine mounting screws.
7. Perform the controller calibration procedures and, if necessary, the appropriate remote set point calibration procedure in Section 3, 4, or 5.
8. Mount the controller as described in the Installation section.
9. Connect the external piping to the controller.

Replacing the Proportional Band Adjustment Knob, Nozzle Assembly, and Set Point Beam Assembly

WARNING

Refer to the Maintenance **WARNING** on page 6-1.

Figure 6-3 shows the parts locations for the proportional band adjustment and set point beam. Unless otherwise noted, refer to this figure while performing the following procedures.

Disassembly

1. Remove the controller assembly from the case by performing steps 1 through 3 of the case and cover replacement procedure.
2. Remove the two machine screws (key 6) and lift off the proportional band indicator cover (key 36). See figure 7-1 for parts location.
3. Disconnect link 3 from the set point beam shoe, part of the set point beam assembly (key 23).
4. Remove the set point beam bias spring (key 28).
5. Remove the screw and washer (keys 19 and 20) that hold the adjustable set point pivot assembly (key 17) to the frame and remove the pivot assembly.
6. Unscrew the nut that secures the relay nozzle tubing assembly (key 18) to the frame manifold (key 135).
7. While holding the proportional band adjustment knob, remove the screw and washer (keys 19 and 20) that hold the relay nozzle tubing assembly (key 18) to the frame.
8. Remove the proportional band adjustment knob, relay nozzle tubing assembly, and set point beam assembly from the controller.
9. Remove the relay nozzle tubing assembly (key 18) from the set point beam assembly (key 23).
10. Remove the E-ring (key 27) from the nozzle assembly (key 21).
11. Remove the nozzle assembly (key 21) and plastic washer (key 22) from the bottom of the set point beam assembly (key 23).
12. Remove the retaining clip (key 26).
13. Remove the proportional band adjustment knob (key 25) and plastic washer from the set point beam assembly (key 23).
14. Inspect the nozzle assembly (key 21) and, if necessary, replace it. Inspect the nozzle orifice and, if necessary, clean it. Also, inspect the plastic washers and, if necessary, replace them.
15. Inspect the nozzle assembly O-ring (key 24) and, if necessary, replace it.

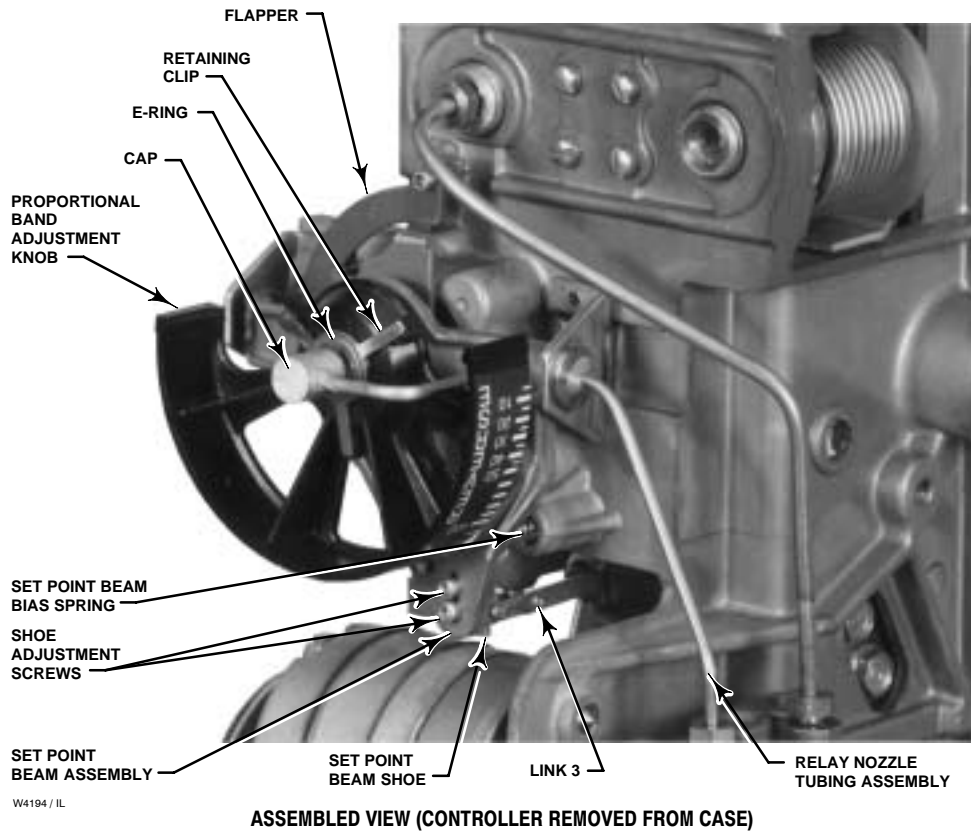
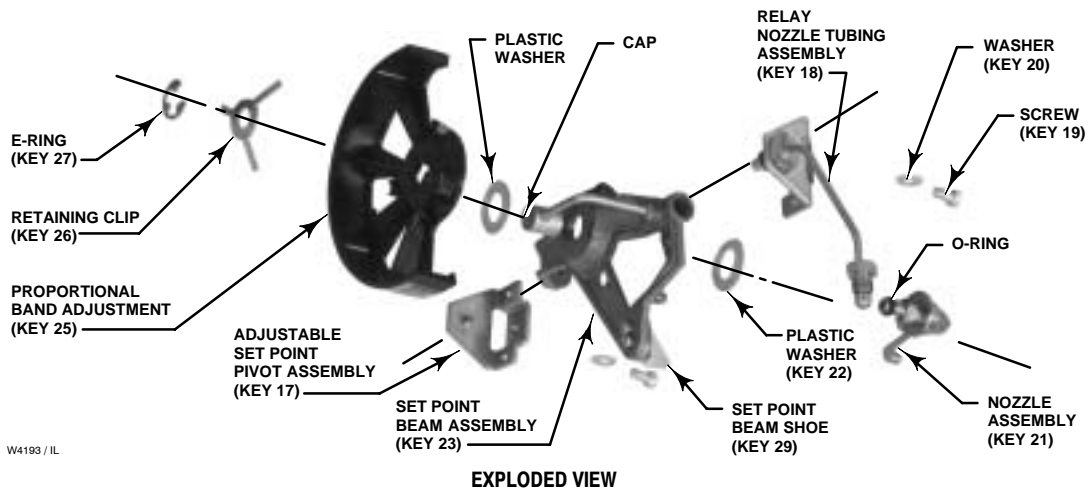
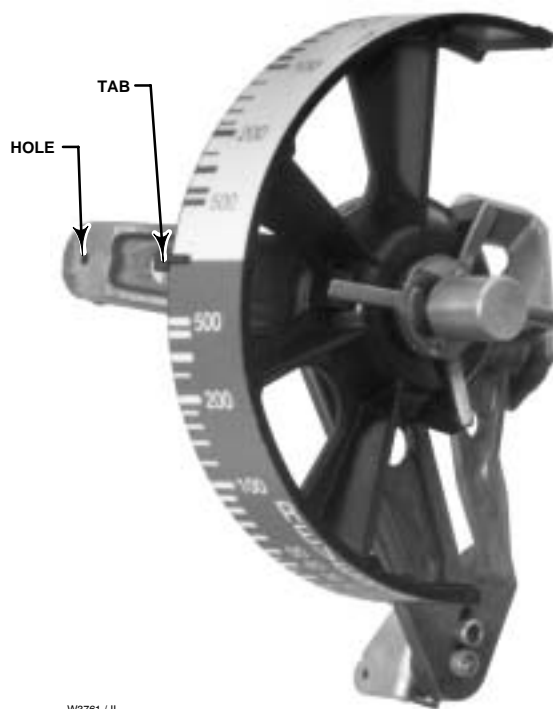

Figure 6-3. Proportional Band Adjustment and Set Point Beam Details

Assembly

1. Apply a suitable lubricant, such as key 318 or equivalent, to the set point beam assembly; then position a plastic washer (key 22) and the proportional band adjustment knob (key 25) on the set point beam assembly (key 23) as shown in figure 6-3.
2. Position the retaining clip (key 26) on the three posts on the proportional band adjustment knob.
3. Place the second plastic washer on the nozzle assembly. Apply a suitable lubricant, such as key 317 or equivalent, to the nozzle assembly O-ring.
4. Insert the nozzle assembly (key 21) through the set point beam assembly (key 23), the plastic washer (key 22), the proportional band adjustment knob (key 25), and the retaining clip (key 26) into the cap. Align the nozzle with the tab on the proportional band adjustment knob shown in figure 6-4; make sure the proportional band adjustment knob engages the flats on the nozzle assembly.
5. While holding the nozzle assembly (key 21) against the set point beam assembly (key 23), depress the retaining clip (key 26), and install the E-ring (key 27) into the E-ring groove on the nozzle assembly (key 21). Ensure that all three tabs of the E-ring are engaged.
6. Inspect the O-ring on the relay nozzle tubing assembly (key 18) and, if necessary, replace it. Apply a suitable lubricant to the O-ring.
7. Install the relay nozzle tubing assembly (key 18) into the set point beam assembly.
8. Set the proportional band adjustment between DIRECT and REVERSE. Do this by aligning the tab on the proportional band adjustment knob with the hole in the set point beam assembly as shown in figure 6-4.
9. Position the proportional band adjustment knob, relay nozzle tubing assembly, and the set point beam assembly on the frame. Screw the relay nozzle tubing nut loosely into the frame manifold.
10. Insert the machine screw, with plain washer (keys 19 and 20), through the frame and start it into the relay nozzle tubing assembly (key 18), but do not tighten.



W3761 / IL

Figure 6-4. Proportional Band Adjustment Knob Setting

11. Center the nozzle on the flapper as shown in figure 6-5 while squeezing the set point beam assembly firmly against the relay nozzle tubing assembly. With the nozzle centered on the flapper, tighten the machine screw (key 19). Ensure that the nozzle is still centered on the flapper.
12. Insert the pivot of the adjustable set point pivot assembly (key 17) into the hole in the set point beam assembly (key 23).
13. Insert the screw, with washer (keys 19 and 20), through the frame (key 3) and start it into the adjustable set point pivot assembly (key 17), but do not tighten.
14. Squeeze the adjustable set point pivot assembly against the set point beam assembly. Check to be sure the nozzle is still centered on the flapper and tighten the machine screw (key 19). If necessary, loosen both machine screws (key 19) to allow slightly moving the adjustable set point pivot assembly, set point beam assembly and the relay nozzle tubing assembly as a unit to center the nozzle on the flapper. After centering the nozzle, tighten the two machine screws.

4195KA, KB, KC, and KS Controllers



W3449 / IL

Figure 6-5. Nozzle-Flapper Positioning

15. Turn the proportional band adjustment knob to 5 percent DIRECT. Refer to figure 6-6 to locate the locking nut on the adjustable set point pivot assembly. Loosen the locking nut and back out the set screw slightly so that the set point beam assembly falls under its own weight when pivoted upward. Also, maintain a minimum side play between the adjustable set point pivot assembly and the nozzle tubing assembly. Tighten the locking nut.

16. At the frame manifold (key 135), tighten the nut that secures the tubing from the relay nozzle tubing assembly (key 18). Apply full supply pressure with the nozzle capped and check for leaks. Remove supply pressure.

17. Install the set point beam bias spring (key 28) into the frame bore and onto the spring seat on the set point beam assembly.

18. Attach link 3 to the set point beam shoe as shown in figure 6-3.

19. For controllers with reset or rate adjustment (4195KB or 4195KC Series), turn the reset adjustment to the CLOSED (4195KB) or OFF (4195KC) position. Set the rate adjustment to the OFF position.

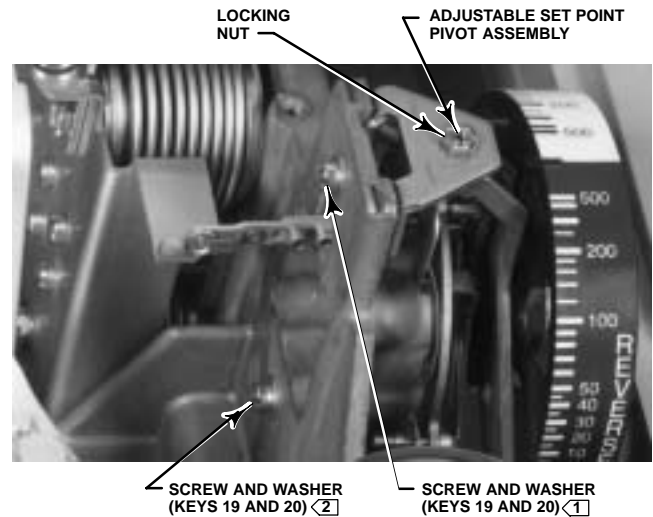

NOTES:

- <1> SCREW INSERTED INTO THE ADJUSTABLE SET POINT PIVOT ASSEMBLY.
- <2> SCREW INSERTED INTO THE RELAY NOZZLE TUBING ASSEMBLY.

W4195 / IL

Figure 6-6. Adjustable Set Point Pivot Assembly Locking Nut Location

The controller output must be 0 bar (0 psig). To be sure the controller output is 0 bar (0 psig), remove supply pressure, set the reset adjustment to 0.01 minutes per repeat and wait 30 seconds; then, turn the reset adjustment to the CLOSED position (4195KB) or to the OFF position (4195KC).

20. Apply the correct supply pressure (refer to table 1-6) to the controller and provide an accurate means of measuring the controller output pressure.

21. Perform the appropriate process indicator zero and span calibration procedure and, if necessary, the remote set point zero and span calibration procedure in Section 3, 4, or 5. When calibration is complete, continue with step 22 below.

Note

The following procedure (steps 22 through 28) matches the process pointer motion to the set point indicator motion so the controller will control at set point at all positions on the process scale.

22. Set the proportional band to 40 percent in REVERSE or DIRECT depending on the desired controller action.

23. Adjust the set point to the lower limit on the process scale.

24. Disconnect link 1 from the input element, noting the hole from which it is removed, for capsular input elements, and tape the process pointer to the lower limit on the process scale. The output pressure may be anywhere between 0.2 to 1.0 bar (3 to 15 psig) for a 0.2 to 1.0 bar (3 to 15 psig) output signal range or between 0.4 to 2.0 bar (6 to 30 psig) for a 0.4 to 2.0 bar (6 to 30 psig) output signal range. If the output is not within the specified range, adjust the flapper leveling screw nearest the nozzle until the output is within the range specified. Record the controller output pressure.

25. Adjust the set point to the upper limit on the process scale.

26. Remove the tape and move the process pointer until the controller output equals the pressure recorded in step 24. Note the process pressure indication.

27. The process pressure indication should be within ± 2 percent of the upper limit on the process scale.

If the process pressure indication in step 26 is greater than the upper limit of the process scale by 2 percent, loosen the shoe adjustment screws (key 30), shown in figure 6-3, and move the set point beam shoe (key 29) slightly away from the center of the flapper assembly.

If the process pressure indication in step 26 is less than the upper limit of the process scale by 2 percent, loosen the shoe adjustment screws (key 30), shown in figure 6-3, and move the set point beam shoe (key 29) slightly toward the center of the flapper assembly.

28. Repeat steps 23 through 27 until the error is less than 2 percent of process scale span at the upper limit of the process scale.

29. Remove the tape from the process pointer and reconnect link 1 to the input element. If the controller has a capsular input element, be sure to reconnect link 1 in the same hole noted in step 24.

30. Position the controller assembly in the case and start, but do not tighten the nine mounting screws. Slide the controller assembly down to assure an O-ring seal at the pressure connections along the bottom of the case. Hold the controller assembly in place while tightening the nine mounting screws.

31. Perform the controller calibration procedures and, if necessary, the appropriate remote set point calibration procedure in Section 3, 4, or 5.

32. Mount the controller as described in the Installation section.

33. Connect the external piping to the controller.

Replacing the Flapper Assembly and Flapper Flexure Pivot Assembly

WARNING

Refer to the Maintenance WARNING on page 6-1.

1. Remove the controller assembly from the case by performing steps 1 through 3 of the case and cover replacement procedure.
2. Remove the two screws (key 6) and lift off the proportional band indicator cover (key 36).
3. Disconnect link 3 from the set point beam shoe, part of the set point beam assembly (key 23). Refer to figure 6-3 for the link location.
4. Remove the set point beam bias spring (key 28). Refer to figure 6-3 for the spring location.
5. Remove the screw and washer (keys 19 and 20) that hold the adjustable set point pivot assembly (key 17) to the frame.
6. Remove the adjustable set point pivot assembly (key 17).
7. Unscrew the nut that secures the relay nozzle tubing assembly (key 18) to the frame manifold (key 135). Refer to figure 6-3.
8. While holding the proportional band adjustment knob, remove the screw and washer (keys 19 and 20) that hold the relay nozzle tubing assembly (key 18) to the frame.
9. Remove the proportional band adjustment knob, relay nozzle tubing assembly, and the set point beam assembly from the controller.
10. Disconnect link 2 from the flapper assembly (key 11). Refer to figure 6-7 for the link location.
11. Disconnect link 4 from the bellows bracket (key 31). Refer to figure 6-7 for the link location.
12. Remove the two cap screws (key 12) from the flexure pivot assembly (key 9). See figure 6-8 for screw location.

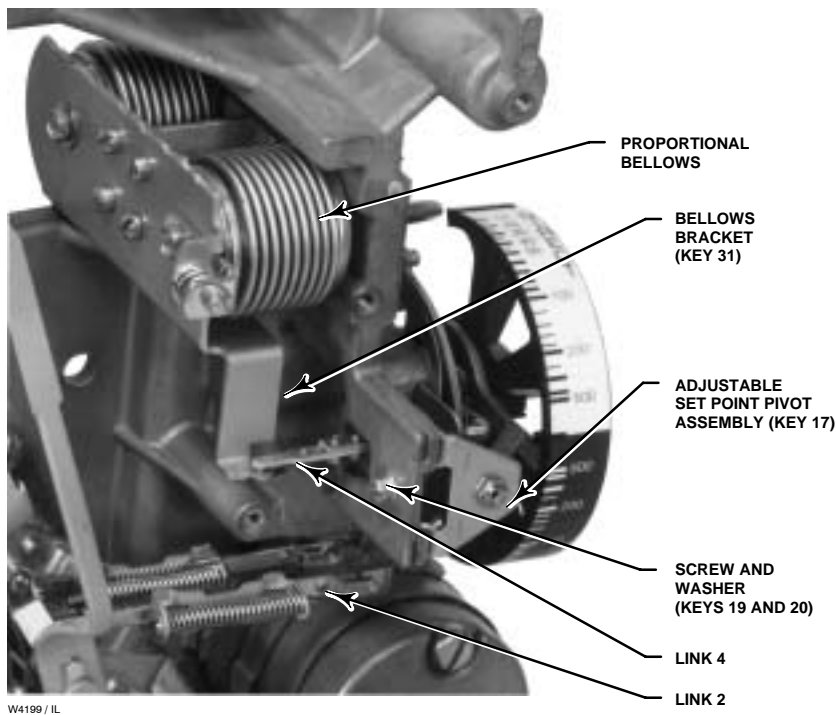

Figure 6-7. Bellows Assembly and Proportional Band Adjustment
(Process Scale and Proportional Band Indicator Cover Removed)

13. Remove the flapper assembly and link 4 as shown in figure 6-9.

14. Remove the four machine screws (key 10), shown in figure 6-9, that hold the flexure pivot assembly to the frame.

15. Remove the flexure pivot assembly (key 9).

16. Install the replacement flexure pivot assembly with the four screws (key 10). Do not tighten the screws.

17. With the controller in the upright position, move the flexure pivot assembly down as far as possible and tighten the four screws (key 10).

18. Place the flapper assembly (key 11) on the flexure pivot assembly (key 9) with link 4 through the hole in the frame.

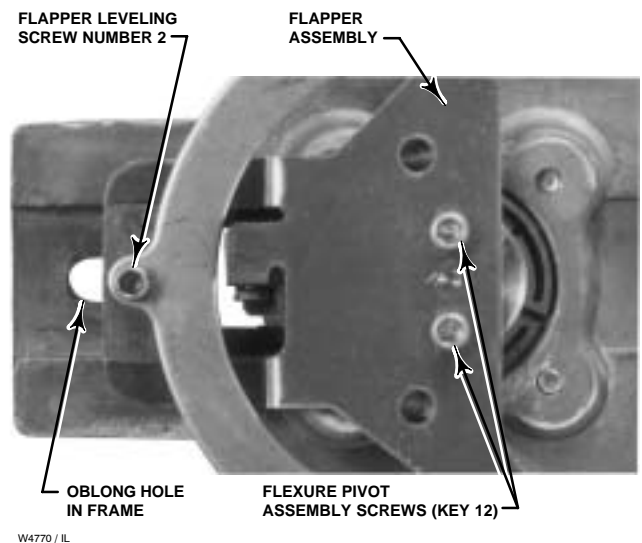
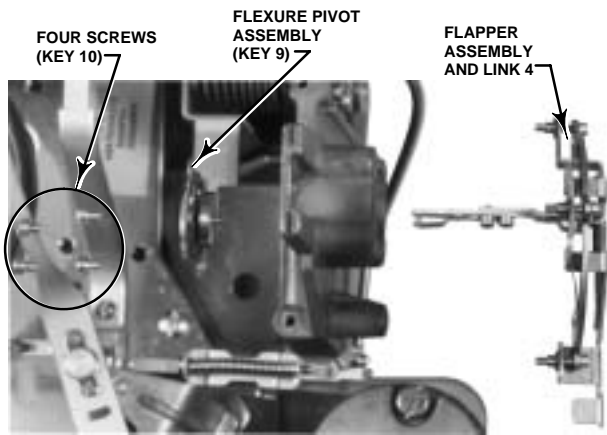

Figure 6-8. Leveling Screw Alignment



W4198 / IL

Figure 6-9. Exploded View of Flexure Pivot Assembly

19. Position the flapper assembly (key 11) on the flexure pivot assembly (key 9) and start the cap screws (key 12) that hold the flapper assembly to the flexure pivot assembly. Do not tighten the screws.

20. Align flapper leveling screw number 2 with the centerline of the oblong hole in the frame as shown in figure 6-8. Tighten the cap screws (key 12).

Note

The following procedure (steps 21 through 23) adjusts link 2 to ensure that it will always be in tension to eliminate possible instability due to lost motion.

21. Disconnect link 1 from the input element, noting the hole location if the controller has a capsular input element, and manually position the process pointer to the process scale upper limit. Tape the pointer in this position.

22. Adjust the length of link 2 by turning the adjustment screw, shown in figure 6-10, clockwise to increase the length or counterclockwise to

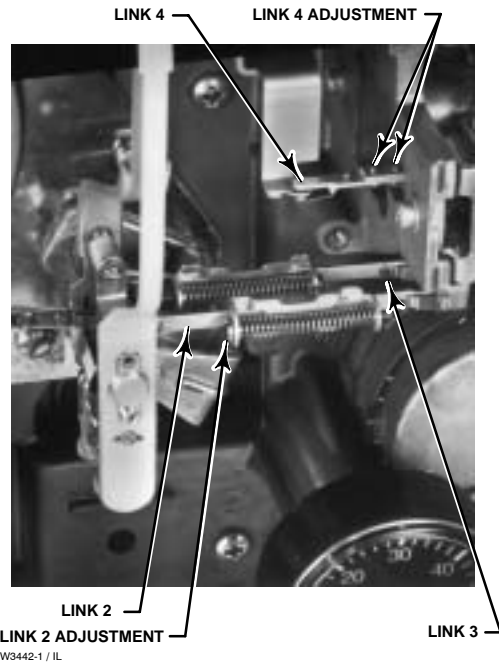

W3442-1 / IL

Figure 6-10. Link 2 and 4 Adjustment Locations

decrease the length, so that the pin on the end of the link is approximately one-half of its diameter short of aligning with the hole in the flapper assembly, as shown in figure 6-11.

23. Connect link 2 to the flapper assembly.

24. Set the proportional band between DIRECT and REVERSE. Do this by aligning the tab on the proportional band adjustment knob with the hole in the set point beam assembly as shown in figure 6-4.

25. Position the proportional band adjustment knob, nozzle assembly, and set point beam assembly, and nozzle tubing assembly on the frame, and screw the relay nozzle tubing assembly nut loosely into the frame manifold (key 135).

26. Insert the machine screw, with washer (keys 19 and 20), through the frame and start it into the relay nozzle tubing assembly (key 18), but do not tighten.

27. Center the nozzle on the flapper as shown in figure 6-5 while squeezing the set point beam assembly firmly against the relay nozzle tubing assembly. With the nozzle centered on the flapper, tighten the machine screw (key 19). Ensure that the nozzle is still centered on the flapper.

4195KA, KB, KC, and KS Controllers

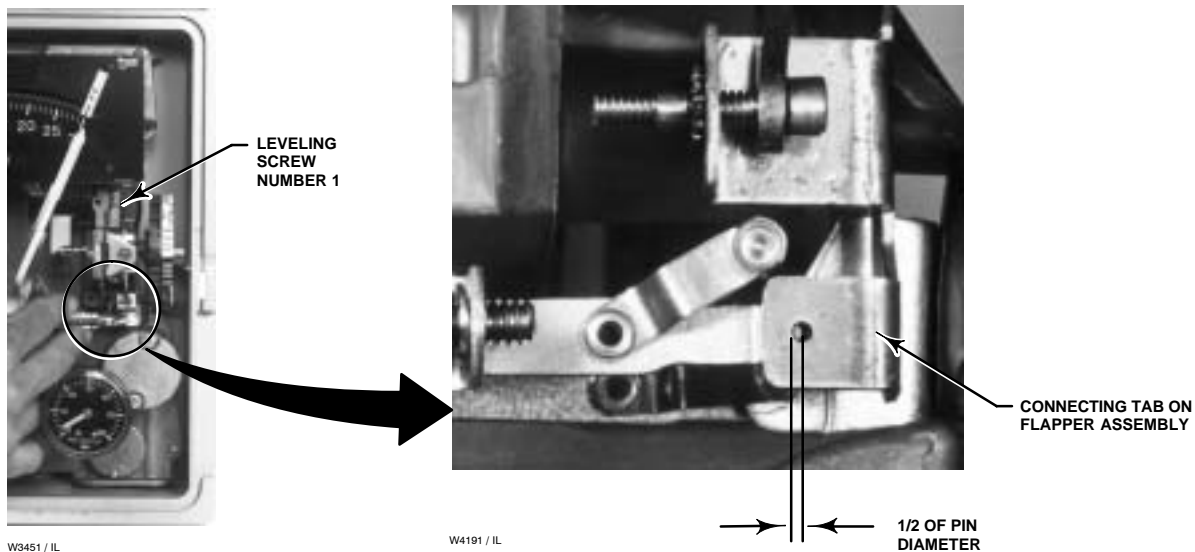

Figure 6-11. Link 2 Adjustment

28. Insert the pivot of the adjustable set point pivot assembly (key 17) into the hole in the set point beam assembly (key 23).

29. Insert the screw, with washer (keys 19 and 20), through the frame (key 3) and start it into the adjustable set point pivot assembly (key 17), but do not tighten.

30. Squeeze the adjustable set point pivot assembly against the set point beam assembly. Check to be sure the nozzle is still centered on the flapper and tighten the machine screw (key 19). If necessary, loosen both machine screws (key 19) to allow slightly moving the adjustable set point pivot assembly, set point beam assembly and the relay nozzle tubing assembly as a unit to center the nozzle on the flapper. After centering the nozzle, tighten the two machine screws.

31. Turn the proportional band adjustment knob to 5 percent DIRECT. Refer to figure 6-6 to locate the locking nut on the adjustable set point pivot assembly. Loosen the locking nut and back out the set screw slightly so that the set point beam assembly falls under its own weight when pivoted upward. Also, maintain a minimum side play between the adjustable set point pivot assembly and the nozzle tubing assembly. Tighten the locking nut.

32. At the frame manifold (key 135), tighten the nut that secures the tubing from the relay nozzle tubing assembly (key 18). Apply full supply pressure with the nozzle capped (to obtain maximum output pressure) and check for leaks. Remove supply pressure.

33. Install the set point beam bias spring (key 28) into the frame bore and onto the spring seat on the set point beam assembly, as shown in figure 6-3.

34. Attach link 3 to the set point beam shoe as shown in figure 6-3.

Note

The following procedure (steps 35 through 41) adjusts link 4 so it will always be in compression to eliminate possible instability due to lost motion.

35. For controllers with reset and rate adjustments (4195KB or 4195KC Series), remove the supply pressure; then turn the reset adjustment to the CLOSED (4195KB) or OFF (4195KC) position.

The controller output must be 0 bar (0 psig). To be sure the controller output is 0 bar (0 psig), remove supply pressure, set the reset adjustment to 0.01 minutes per repeat and wait 30 seconds; then, turn the reset adjustment to the CLOSED (4195KB) or OFF (4195KC) position.

36. Apply the correct supply pressure (refer to table 1-6) to the controller and provide an accurate means of measuring the controller output pressure.

37. Adjust the proportional band to 5 percent REVERSE and adjust the set point to the process scale upper limit.

38. With link 1 disconnected, tape the process pointer at the process scale lower limit. The output pressure should be within 0.14 bar (2 psig) of the

supply pressure. If not, adjust flapper leveling screw 1 (the screw nearest the nozzle) until the output is within 0.14 bar (2 psig) of supply pressure.

39. Loosen the two adjustment screws on link 4, shown in figure 6-10, and connect the link to the bellows bracket (key 31), allowing the link to find its free length.

40. Tighten the two adjusting screws on link 4.

41. Lift link 4 out of the hole in the bellows bracket (key 31) and ensure it drops back into the hole under its own weight. If not, repeat steps 39 and 40.

42. Adjust the proportional band to 40 percent REVERSE or DIRECT depending on the desired controller action.

43. Adjust the set point to the process scale lower limit.

44. Tape the process pointer at the process scale lower limit. The output pressure may be anywhere between 0.2 to 1.0 bar (3 and 15 psig) for a 0.2 to 1.0 bar (3 to 15 psig) output signal range or between 0.4 to 2.0 bar (6 and 30 psig) for a 0.4 to 2.0 bar (6 to 30 psig) output signal range. If the output is not within the specified range, adjust the flapper leveling screw nearest the nozzle until the output is within the range specified. Record the controller output pressure.

45. Adjust the set point to the process scale upper limit.

46. Remove the tape and move the process pointer until the controller output equals the pressure recorded in step 44. Note the process pressure indication.

47. The process pressure indication should be within ± 2 percent of the process scale upper limit.

If the process pressure indication in step 46 is greater than the process scale upper limit by 2 percent, loosen the shoe adjustment screws (key 30), shown in figure 6-3, and move the set point beam shoe (key 29) slightly away from the center of the flapper assembly.

If the process pressure indication in step 46 is less than the process scale upper limit by 2 percent, loosen the shoe adjustment screws (key 30), shown

in figure 6-3, and move the set point beam shoe (key 29) slightly toward the center of the flapper assembly.

48. Repeat steps 43 through 47 until the error is less than 2 percent of the process scale span at the process scale upper limit.

49. Remove the tape from the process pointer and reconnect link 1 to the input element. If the controller has a capsular input element, be sure to reconnect link 1 in the same hole noted in step 21.

50. Position the controller assembly in the case and start, but do not tighten the nine mounting screws. Slide the controller assembly down to assure an O-ring seal at the pressure connections along the bottom of the case. Hold the controller assembly in place while tightening the nine mounting screws.

51. Perform the controller calibration procedures and, if necessary, the appropriate remote set point calibration procedure in Section 3, 4, or 5.

52. Mount the controller as described in the Installation section.

53. Connect the external piping to the controller.

Replacing the Proportional, Reset or Positive Feedback Bellows

WARNING

Refer to the Maintenance WARNING on page 6-1.

Refer to figure 6-12, unless otherwise noted.

1. Remove the controller assembly from the case by performing steps 1 through 3 of the case and cover replacement procedure.

2. Remove the two screws (key 6) and lift off the proportional band indicator cover (key 36).

3. Disconnect link 4 (key 65) from the bellows bracket (key 31).

4. Remove the two machine screws (key 35) and washer (key 362) from the bellows assemblies.

4195KA, KB, KC, and KS Controllers

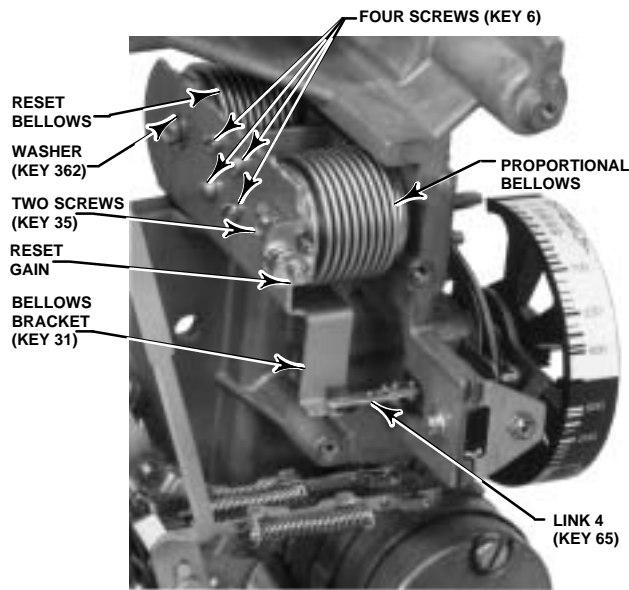

W4199 / IL

Figure 6-12. Bellows Assembly, Bellows Bracket, and Bellows Beam Location

5. Remove the four machine screws (key 6) from the bellows beam (key 49) and remove the bellows bracket (key 31).
6. Remove the proportional tubing assembly (key 40) from the proportional bellows, the reset tubing assembly (key 43) from the reset bellows or the positive feedback tubing assembly (key 45) from the positive feedback bellows, depending on which bellows is to be replaced.
7. Remove the four machine screws (key 71) from the bellows beam and remove the bellows beam from the frame.

CAUTION

When removing and replacing the proportional, reset, or positive feedback bellows, keep in mind that the bellows has left-hand threads. Overtightening could damage the threads.

Note

Both bellows need not be removed if only one requires replacement.

8. Unscrew the bellows assembly (key 48). If the bellows assembly cannot be removed by hand, thread a machine screw (key 35) into the bellows until tight; then loosen the bellows assembly by applying clockwise torque to the machine screw.

9. Before installing the replacement bellows, coat the threads with a suitable lubricant, such as key 310. Screw in the replacement bellows until it is finger tight against the frame (key 3).

10. Reinstall the bellows beam (key 49) and tighten the machine screws (key 71).

11. Position the bellows bracket (key 31) over the bellows. Insert a machine screw (key 35) through the bellows bracket (key 31) and into the proportional bellows. Do not tighten.

12. Place the washer (key 362) on the second machine screw (key 35) and start the screw through the bellows bracket (key 31) into the reset bellows. Do not tighten.

13. Compress the bellows and start the four machine screws (key 6) through the bellows bracket (key 31) into the bellows beam (key 49), but do not tighten.

14. Be sure that the bellows bracket is aligned such that it does not rub on the frame at any point and tighten the screws (keys 6 and 35).

15. Install the proportional, reset, or positive feedback tubing assembly on the bellows base.

16. For a 4195KB or KC Series controller, set the reset adjustment for 0.01 minutes per repeat. For a 4195KC Series controller, set the rate adjustment to OFF.

17. Apply the correct supply pressure with the nozzle capped and check for leaks. Remove the supply pressure.

18. Reconnect link 4 (key 65) to the bellows bracket. Be sure that the link does not contact the frame. If it does, loosen the four screws (key 6) that attach the bellows bracket to the bellows beam and reposition the bellows bracket to provide clearance. Be sure the bellows bracket does not rub on the frame; then, tighten the screws.

19. Lift link 4 out of the hole in the bellows bracket (key 31) and ensure it drops back into the hole under its own weight. If not, perform steps 35 through 41 of the flapper assembly and flapper flexure pivot assembly replacement procedures.

20. If the controller is a proportional-only (4195KA or KS Series), go to step 33. If the controller has reset (4195KB or KC Series), continue with step 21.

Note

The following procedure (steps 21 through 32) adjusts the reset gain of the controller to minimize steady-state offset.

21. Apply the correct supply pressure (refer to table 1-6) to the controller and provide an accurate means of measuring the controller output pressure. Also provide a means of applying regulated process pressure.
22. Adjust the proportional band to 100 percent DIRECT.
23. Adjust the set point to the mid-scale mark on the process scale.
24. Adjust the reset adjustment to 0.01 minutes per repeat. For a 4195KC Series controller, set the rate adjustment to OFF.
25. Increase the process pressure until the output pressure stabilizes at 0.2 bar (3 psig) for a 0.2 to 1.0 bar (3 to 15 psig) output or 0.4 bar (6 psig) for a 0.4 to 2.0 bar (6 to 30 psig) output. Record the process pressure reading.

Note

When the reset valve is at 0.01, the controller is very sensitive to any process pressure change. Only small process pressure changes may be necessary.

26. Very slowly increase the process pressure until the output pressure stabilizes at 1.0 bar (15 psig) for a 0.2 to 1.0 bar (3 to 15 psig) output or 2.0 bar (30 psig) for a 0.4 to 2.0 bar (6 to 30 psig) output. Record the process pressure reading.
27. If the difference between the recorded process pressure in step 25 and the process pressure in step 26 is larger than ± 1 percent of the process scale span, proceed with step 28. If the difference is less than ± 1 percent, go to step 33.
28. Loosen the proportional bellows screw (key 35).
29. If the reading recorded in step 26 is greater than in step 25, adjust the reset gain screw (key 34) one-half turn in (clockwise). If the reading recorded in step 26 is less than in step 25, adjust the gain screw (key 34) one-half turn out (counterclockwise).
30. Tighten the proportional bellows screw (key 35).
31. Repeat steps 25 through 30 until the difference is less than ± 1 percent of the process scale span.

32. If ± 1 percent of process scale span cannot be achieved by adjusting the gain screw (key 34), loosen the machine screw (key 35) attaching the reset bellows and slide it to the left if the reading in step 26 is greater than in step 25, or to the right if the reading in step 26 is less than in step 25. Tighten the screw and repeat steps 25 through 31.

33. Remove the supply pressure, the output measurement device, and the regulated process pressure source.
34. Position the controller assembly in the case and start, but do not tighten the nine mounting screws. Slide the controller assembly down to assure an O-ring seal at the pressure connections along the bottom of the case. Hold the controller assembly in place while tightening the nine mounting screws.
35. Perform the controller calibration procedures and, if necessary, the appropriate remote set point calibration procedure in Section 3, 4, or 5.
36. Mount the controller as described in the Installation section.
37. Connect the external piping to the controller.

Replacing the Reset Restriction Valve (4195KB Series)



Refer to the Maintenance WARNING on page 6-1.

Refer to the 4195KB Series portion of figure 7-1 for key number locations.

1. Remove the controller assembly from the case by performing steps 1 through 3 of the case and cover replacement procedure.
2. Remove the reset valve tubing assembly (key 42) from the reset restriction valve (key 54).
3. Remove the reset tubing assembly (key 43) from the reset restriction valve.
4. For controllers with anti-reset windup (suffix letter F), remove the relief valve tubing assembly (key 44) from the reset restriction valve.
5. Remove the screw (key 162) that fastens the reset restriction valve to the frame.
6. Install the replacement reset restriction valve and secure it with the screw removed in step 5.
7. Install the reset valve tubing assembly (key 42), the reset tubing assembly (key 43), and for controllers with anti-reset windup, the relief tubing assembly (key 44). Tighten all connections.

4195KA, KB, KC, and KS Controllers

8. Set the reset adjustment to 0.01 minutes per repeat.
9. Apply the proper supply pressure to the controller, cap the nozzle and check for leaks. Remove the supply pressure.
10. Position the controller assembly in the case and start, but do not tighten the nine mounting screws. Slide the controller assembly down to assure an O-ring seal at the pressure connections along the bottom of the case. Hold the controller assembly in place while tightening the nine mounting screws.
11. Perform the controller calibration procedures and, if necessary, the appropriate remote set point calibration procedure in Section 4.
12. Mount the controller as described in the Installation section.
13. Connect the external piping to the controller.

Replacing the Rate/Reset Valve Assembly (4195KC Series)



Refer to the Maintenance WARNING on page 6-1.

Note

Read this entire procedure before removing any parts. Refer to the 4195KC Series portion of figure 7-1 for key number locations.

1. Remove the controller assembly from the case by performing steps 1 through 3 of the case and cover replacement procedure.
2. Remove the two machine screws (key 71) on the side of the rate/reset valve assembly (key 262).
3. Gently pull the rate tubing assembly away from the rate/reset assembly and, remove the gasket (key 5) from the side of the rate/reset assembly.
4. Unscrew the nut holding the reset tubing assembly (key 43) into the rate/reset valve assembly.
5. Unscrew the nut holding the proportional tubing assembly (key 40) into the rate/reset assembly.
6. For controllers with anti-reset windup (suffix letter F), unscrew the nut holding the relief tubing assembly (key 44) into the rate/reset assembly.
7. While holding the rate/reset valve assembly, remove the machine screw (key 162) from the frame.
8. Remove the rate/reset valve assembly from the frame.
9. Inspect and, if necessary, replace the gasket (key 5).
10. To install the replacement rate/reset valve assembly, position the assembly on the frame (key 3) and secure it with the mounting screw (key 162).
11. Position the gasket (key 5) on the rate/reset valve assembly. Hold the gasket in place while installing the rate tubing assembly (key 137) on the valve assembly using the two machine screws (key 71).
12. Insert the reset tubing assembly (key 43) into the rate/reset valve assembly and tighten the nut.
13. Insert the proportional tubing assembly (key 40) into the rate/reset valve assembly and tighten the nut.
14. For controllers with anti-reset windup (suffix letter F), insert the relief tubing assembly (key 44) into the rate/reset valve assembly and tighten the nut.
15. Set the reset to 0.01 minutes per repeat and the rate to OFF.
16. Apply the proper supply pressure to the controller and check for leaks. Remove the supply pressure.
17. Position the controller assembly in the case and start, but do not tighten the nine mounting screws. Slide the controller assembly down to assure an O-ring seal at the pressure connections along the bottom of the case. Hold the controller assembly in place while tightening the nine mounting screws.
18. Perform the controller calibration procedures and, if necessary, the appropriate remote set point calibration procedure in Section 4.
19. Mount the controller as described in the Installation section.
20. Connect the external piping to the controller.

Replacing the Anti-Reset Windup (suffix letter F) Differential Relief Valve



Refer to the Maintenance **WARNING** on page 6-1.

Refer to the 4195KB or 4195KC Series suffix letter F portion of figure 7-1 for key number locations.

1. Loosen the two mounting screws in the differential relief valve (key 55) and remove the relief valve.
2. Inspect the O-rings on the replacement relief valve. Apply a suitable lubricant to the O-rings.
3. Install the replacement relief valve into the controller frame, keeping in mind that:

- When the arrow points up, the valve relieves with decreasing output pressure.
- When the arrow points down, the valve relieves with increasing output pressure.

4. Tighten the two screws that hold the relief valve to the frame.
5. The relief valve differential pressure is factory-set at 0.3 bar (5 psig). Maximum differential pressure is 0.5 bar (7 psig); minimum differential pressure is 0.14 bar (2 psig). If a different differential pressure setting is desired, refer to the anti-reset windup valve calibration procedure in Section 4.

Replacing the Anti-Reset Windup (suffix letter F) Relief Valve Tubing Assembly



Refer to the Maintenance **WARNING** on page 6-1.

Refer to the 4195KB or 4195KC Series suffix letter F portion of figure 7-1 for key number locations.

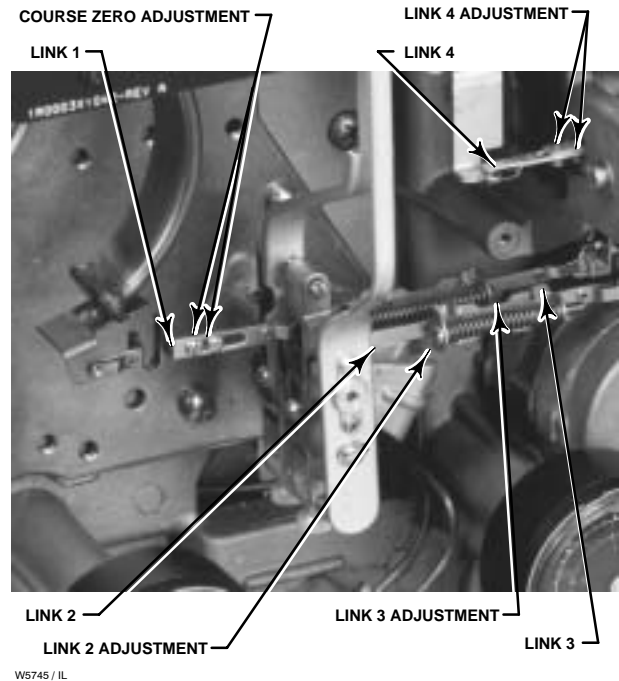

Figure 6-13. Bourdon Tube Controller Link Locations and Adjustments

1. Remove the controller assembly from the case by performing steps 1 through 3 of the case and cover replacement procedure.
2. Loosen the nuts at both ends of the relief valve tubing (key 44) and remove the tubing.
3. Install the replacement relief valve tubing, and tighten the tubing nuts at both ends.
4. Apply the proper supply pressure to the controller, cap the nozzle and check for leaks. Remove the supply pressure.
5. Position the controller assembly in the case and start, but do not tighten the nine mounting screws. Slide the controller assembly down to assure an O-ring seal at the pressure connections along the bottom of the case. Hold the controller assembly in place while tightening the nine mounting screws.
6. Perform the controller calibration procedures and, if necessary, the appropriate remote set point calibration procedure in Section 4.
7. Mount the controller as described in the Installation section.
8. Connect the external piping to the controller.

4195KA, KB, KC, and KS Controllers



W5747 IL

Figure 6-14. Disconnecting Link 1 from the Bourdon Tube

Bourdon Tube Controller Maintenance and Calibration

Replacing the Bourdon Tube

WARNING

Refer to the Maintenance WARNING on page 6-1.

Refer to figure 7-2 for key number locations. Refer to figure 6-13 for a detailed photograph of the Bourdon tube controller link locations and adjustments.

1. Disconnect link 1 (key 382) from the Bourdon tube (key 383) as shown in figure 6-14.
2. Unscrew the tubing nut from the Bourdon tube to allow for Bourdon tube removal.
3. Remove the self-tapping screws (key 384) that fasten the Bourdon tube (key 383) to the indicator assembly (key 101).
4. With care, separate the Bourdon tube (key 383) from the process tubing assembly (key 381) and lift out the Bourdon tube.
5. Carefully place the replacement Bourdon tube in position and start the two self-tapping screws. Connect the process tubing assembly then tighten the self-tapping screws to secure the Bourdon tube.
6. Apply process pressure equal to the process scale upper limit and check for leaks. Remove process pressure.

7. Connect link 1 to the Bourdon tube.
8. With the process pressure at 0 percent, the process pointer should indicate 0 percent on the process scale. If not, loosen the two screws on link 1 and adjust the length of link 1 to position the process pointer at 0 percent. Tighten the screws.
9. Perform the controller calibration procedures and, if necessary, the appropriate remote set point calibration procedure in Section 3, 4, or 5.

Replacing Bourdon Tube Controller Links

WARNING

Refer to the Maintenance WARNING on page 6-1.

This section describes the separate replacement of four links in the controller. Figure 6-13 shows the location of each link. To clarify the location of each link, the links are numbered as follows:

- Link 1 connects the Bourdon tube and the process pointer
- Link 2 connects the process pointer and the flapper assembly (key 11)
- Link 3 connects the set point indicator and the set point beam assembly (key 23)
- Link 4 (key 65) connects the flapper assembly and the bellows bracket (key 31).

Replacing Bourdon Tube Controller Link 1

1. Remove the two screws (key 6), and lift off the proportional band indicator cover (key 36).
2. Note the hole position of link 1 in the process pointer. As shown in figure 6-14, disconnect the link from the Bourdon tube and from the process pointer. Adjust the length of the replacement link to the same length as the link being replaced.
3. Attach the replacement link to the original holes in the process pointer and the Bourdon tube. If you do not know in which hole in the process pointer the link was connected, place it in the middle hole. If during the process indicator zero and span calibration, the pointer will not travel the full scale



W3443-1 / IL

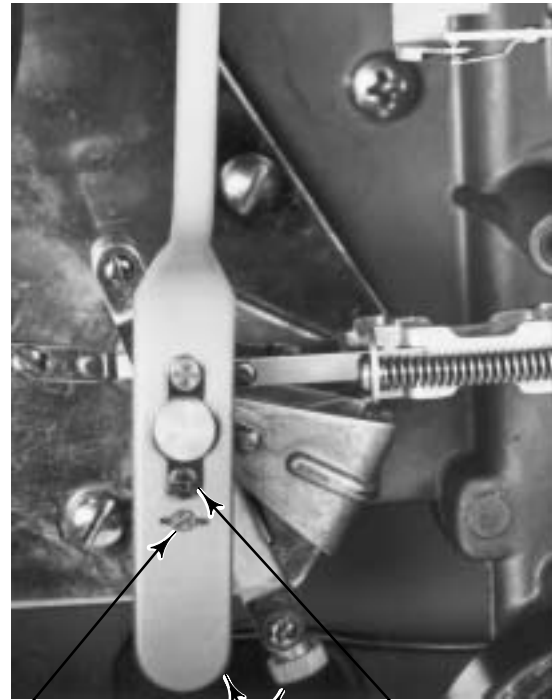

W3475-1 / IL

Figure 6-15. Process Pointer Alignment

even after full span adjustment, move the link to the bottom hole (the hole nearest the pointer pivot). If the process pointer has too much travel, move the link to the top hole (the hole furthest from the pointer pivot).

4. Move the set point Indicator, either manually or with remote set point pressure, to the mid-scale mark on the process scale and set the proportional band between DIRECT and REVERSE.

5. The process pointer should be aligned with the pointer subassembly as shown in figure 6-15. If not, loosen the zero adjustment locking screw and adjust the process pointer zero adjustment to align the process pointer and pointer subassembly. Tighten the zero adjustment locking screw.

6. Apply process pressure equal to the mid-scale value of the process scale span. The process pointer should indicate mid-scale ± 3 percent of the process scale span. If not, loosen the two screws in link 1 and move the process pointer to the mid-scale mark on the process scale. Tighten the screws.

7. Perform the controller calibration procedures and, if necessary, the appropriate remote set point calibration procedure in Section 3, 4, or 5.

Replacing Bourdon Tube Controller Link 2

1. Remove the two screws (key 6), and lift off the proportional band indicator cover (key 36).

2. Disconnect link 2 from the process pointer and from the flapper assembly (key 11). Remove the link.

3. Install the replacement link with the screw head nearest the process pointer as shown in figure 6-13. Connect the link to the process pointer only.

4. The process pointer should be aligned with the pointer subassembly as shown in figure 6-15. If not, loosen the zero adjustment locking screw and adjust the process pointer zero adjustment to align the process pointer and pointer subassembly. Tighten the zero adjustment locking screw.

5. Move the set point indicator, either manually or with the remote set point pressure, to the process scale lower limit and set the proportional band to 5 percent REVERSE. The nozzle should not be touching the flapper. If it is, adjust flapper leveling

4195KA, KB, KC, and KS Controllers

screw 1 (the screw nearest the nozzle) until clearance is obtained.

6. Disconnect link 1 from the Bourdon tube and manually position the process pointer to the process scale upper limit. Tape the pointer in this position.

7. Adjust the length of link 2 (by turning the adjusting screw clockwise to increase the length or counterclockwise to decrease the length) so that the pin on the end of the link is approximately one-half of its diameter short of aligning with the hole in the flapper assembly as shown in figure 6-11. This adjustment provides the proper tension on the link to eliminate lost motion.

8. Connect link 2 to the flapper assembly.

9. Remove the tape from the process pointer and reconnect link 1 to the Bourdon tube.

10. Perform the controller calibration procedures and, if necessary, the appropriate remote set point calibration procedure in Section 3, 4, or 5.

Replacing Bourdon Tube Controller Link 3

1. Remove the two screws (key 6), and lift off the proportional band indicator cover (key 36).
2. Disconnect link 3 from the set point indicator and the set point beam assembly (key 23).
3. Adjust the replacement link to the same length as the link removed.
4. Install the replacement link with the screw head toward the set point beam assembly as shown in figure 6-13.
5. Check that the set point beam bias spring (key 28) is correctly located in the frame bore and the spring seat on the set point beam assembly as shown in figure 6-3.
6. Move the set point indicator to the mid-scale mark on the process scale.
7. Apply process pressure to position the process pointer at the mid-scale mark on the process scale.
8. Adjust the proportional band to 5 percent DIRECT. Turn flapper leveling screw 3 (the screw nearest the nozzle) until the nozzle just touches the flapper.
9. Adjust the proportional band to 5 percent REVERSE. Turn flapper leveling screw 1 (the screw nearest the nozzle) until the nozzle just touches the flapper.
10. Flapper leveling screws 1 and 3 should protrude the same distance from the clinch nuts. A clinch nut is shown in figure 6-16.

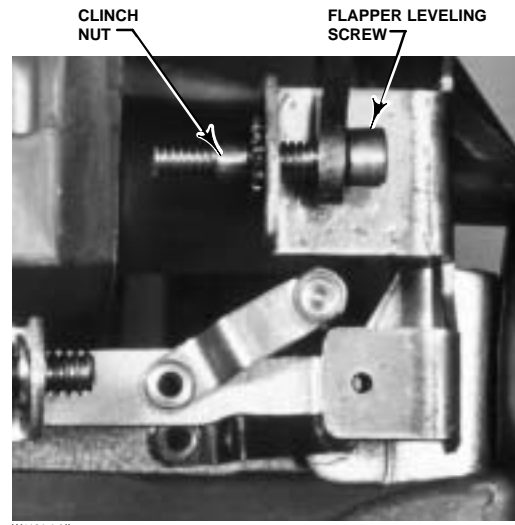

Figure 6-16. Flapper leveling Screw and Clinch Nut

11. If leveling screw 1 protrudes further than leveling screw 3, turn the link 3 adjusting screw counterclockwise. If leveling screw 3 protrudes further than leveling screw 1, turn the link 3 adjusting screw clockwise.
12. Repeat steps 8 through 11 until leveling screws 1 and 3 protrude an equal distance from the clinch nuts.
13. Perform the controller calibration procedures and, if necessary, the appropriate remote set point calibration procedure in Section 3, 4, or 5.

Replacing Bourdon Tube Controller Link 4

1. Remove the two screws (key 6), and lift off the proportional band indicator cover (key 36).
2. Disconnect link 4 from the bellows bracket (key 31) and the flapper assembly (key 11).
3. Connect the replacement link to the flapper assembly so that the two adjusting screws on the link are nearest to the bellows bracket (key 31) and so that the screw heads are facing the bottom of the controller as shown in figure 6-17.
4. For controllers with reset (4195KB Series) or reset and rate adjustments (4195KC Series), turn the reset adjustment to the CLOSED (4195KB) or OFF (4195KC) position. Turn the rate adjustment (4195KC Series) to the OFF position.

The controller output must be 0 bar (0 psig). To be sure the controller output is at 0 bar (0 psig), remove supply pressure, set the reset adjustment to 0.01 minutes per repeat and wait 30 seconds; then, turn the reset adjustment to the CLOSED (4195KB) or OFF (4195KC) position.

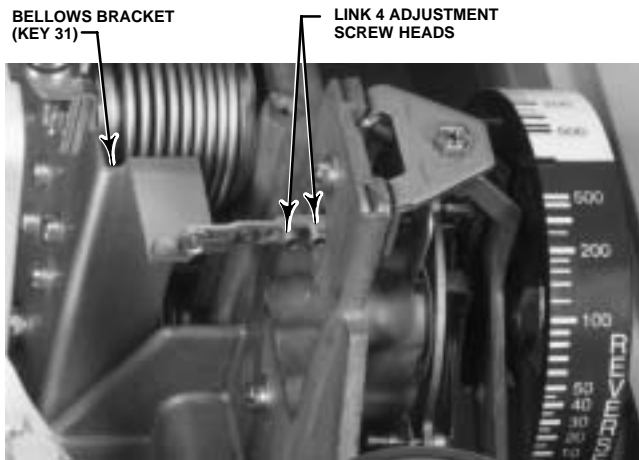

Figure 6-17. Position of Link 4 Adjustment Screws

5. Adjust the proportional band to 5 percent REVERSE and move the set point indicator to the process scale upper limit.
6. Disconnect link 1 from the Bourdon tube and move the process pointer to the process scale lower limit. Tape the process pointer in this position.
7. Apply the correct supply pressure to the controller. The output of the controller should be within 0.14 bar (2 psig) of the supply pressure. If not, adjust flapper leveling screw 1 (the screw nearest the nozzle) until the output is within 0.14 bar (2 psig) of supply pressure.
8. Loosen the two adjusting screws on link 4. Connect the free end of the link to the bellows bracket and allow the link to find its free length.
9. Tighten the two adjusting screws on the link.
10. Raise link 4 out of the hole in the bellows bracket (key 31) and ensure that it drops back into the hole under its own weight. If not, repeat steps 8 and 9.
11. For a controller with reset, adjust the reset adjustment to 0.01 minutes per repeat. The rate adjustment (4195KC) should remain in the OFF position.
12. The controller output should be within 0.14 bar (2 psig) of the supply pressure. If not, adjust flapper leveling screw 1 (the screw nearest the nozzle) until the output is within 0.14 bar (2 psig) of supply pressure.
13. Remove the tape from the process pointer and connect link 1 to the Bourdon tube.

14. Perform the controller calibration procedures and, if necessary, the appropriate remote set point calibration procedure in Section 3, 4, or 5.

Bourdon Tube Travel Stop Installation and Adjustment

⚠ WARNING

Refer to the Maintenance **WARNING** on page 6-1.

Note

The process indicator should be calibrated before installing or adjusting travel stops. Refer to the appropriate process indicator zero and span calibration procedure in Section 3, 4, or 5.

Refer to figure 6-18 for adjustment locations and figure 7-1 for key number locations.

The lower travel stop is necessary only if the operating range lower limit is greater than 0 bar or 0 psig (elevated zero) For example: The process scale limits may be 0 to 300 psig, but the range of operation is 150 to 300 psig. In this example the elevated zero is 150 psig and the lower travel stop would be adjusted for 5 percent of the process scale span less than 150 psig ($150 - (0.05 \times 300) = 135$ psig).

1. Remove the two screws (key 6), and lift off the proportional band indicator cover (key 36).
2. Set the proportional band between DIRECT and REVERSE.
3. Install the upper travel stop (key 73) or upper and lower travel stops (keys 73 and 74) with the machine screws (keys 75 and 76). Do not tighten the machine screws (key 75) that secure the upper travel stop. If only the upper travel stop is installed, go to step 10. Otherwise proceed with step 4.
4. If the operating range lower limit is 0 bar (0 psig), and a lower travel stop is installed, adjust the lower travel stop adjustment so it does not interfere with the Bourdon tube. Tighten the lower travel stop adjustment lock nut and proceed to step 10. If the operating range lower limit is other than 0 psig (elevated zero), perform steps 5 through 15.
5. If the process scale lower limit is other than 0 psig, adjust the process pressure to 5 percent of the process scale span less than the operating range lower limit (see example at the beginning of this procedure).

4195KA, KB, KC, and KS Controllers

6. Adjust the lower travel stop adjustment (shown in figure 6-18) until it touches the Bourdon tube.
7. Tighten the lower travel stop adjustment lock nut.
8. Increase the process pressure to the operating range lower limit.
9. The Bourdon tube should not touch the lower travel stop. If it does, repeat steps 5 through 8.
10. Apply process pressure to the controller equal to 105 percent of the process scale span.
11. Slide the upper travel stop (key 73) until it touches the Bourdon tube.
12. Tighten the machine screws (key 75).
13. Decrease the process pressure to 100 percent of the process scale span.
14. The Bourdon tube should not touch the upper travel stop. If it does, repeat steps 10 through 13.
15. Adjust the proportional band to 400 percent in the desired action and install the proportional band indicator cover (key 36). Tighten the two screws (key 6).

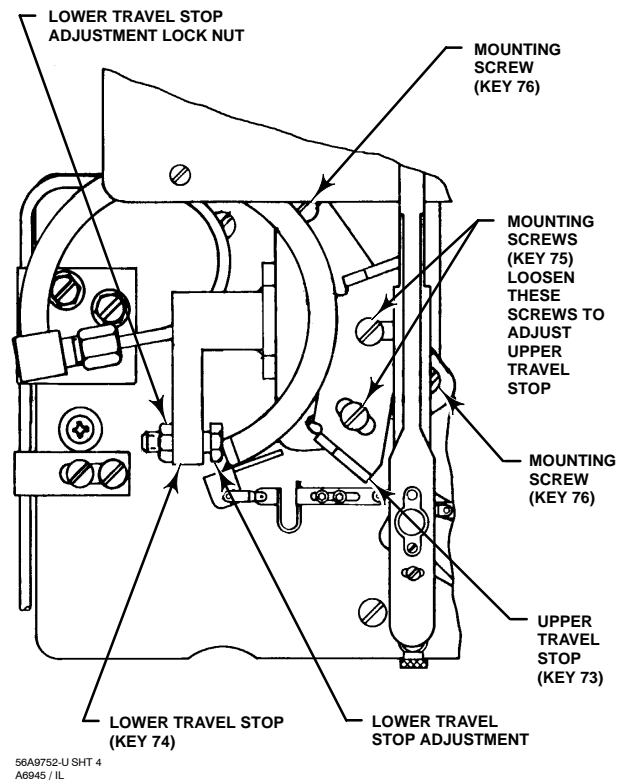

Figure 6-18. Bourdon Tube Controller Travel Stop Adjustment

Bourdon Tube Controller Calibration: Zero and Span Adjustment



Refer to the Maintenance WARNING on page 6-1.

Note

For routine zero and span calibration, refer to the appropriate procedures in Section 3, 4, or 5. Use the following maintenance zero and span adjustment procedure only if difficulty is encountered with the routine procedure or if nonlinearity occurs.

Refer to figure 6-19 for location of adjustments and figure 7-1 for key number locations.

Provide a means of applying process pressure to the Bourdon tube and a regulated supply pressure adjusted to the normal operating pressure (see table 1-6). For 4195KA and KS Series controllers, connect the controller output to an accurate gauge. For 4195KB and KC Series controllers, a gauge is not necessary and the controller output connection may be plugged.

Note

Any adjustment of the process pointer span adjustment screw requires readjustment of the process pointer zero adjustment screw. When checking the zero and span adjustments, ensure that the Bourdon tube does not contact the optional travel stops if used (key 73 and 74).

1. Remove the two screws (key 6), and lift off the proportional band indicator cover (key 36).
2. Set the proportional band adjustment between DIRECT and REVERSE.
3. Set the reset valve (4195KB and KC Series only) to 0.01 minutes per repeat.
4. Set the rate (4195KC Series only) to OFF.

Instruction Manual

Form 5207
April 2007

4195KA, KB, KC, and KS Controllers

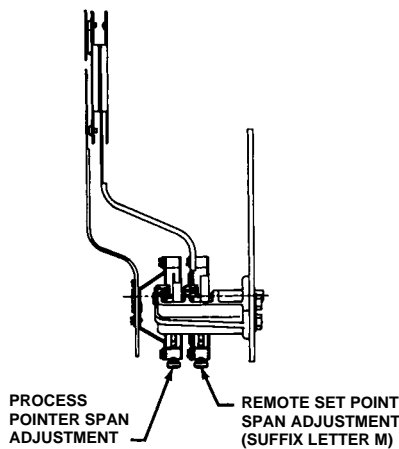
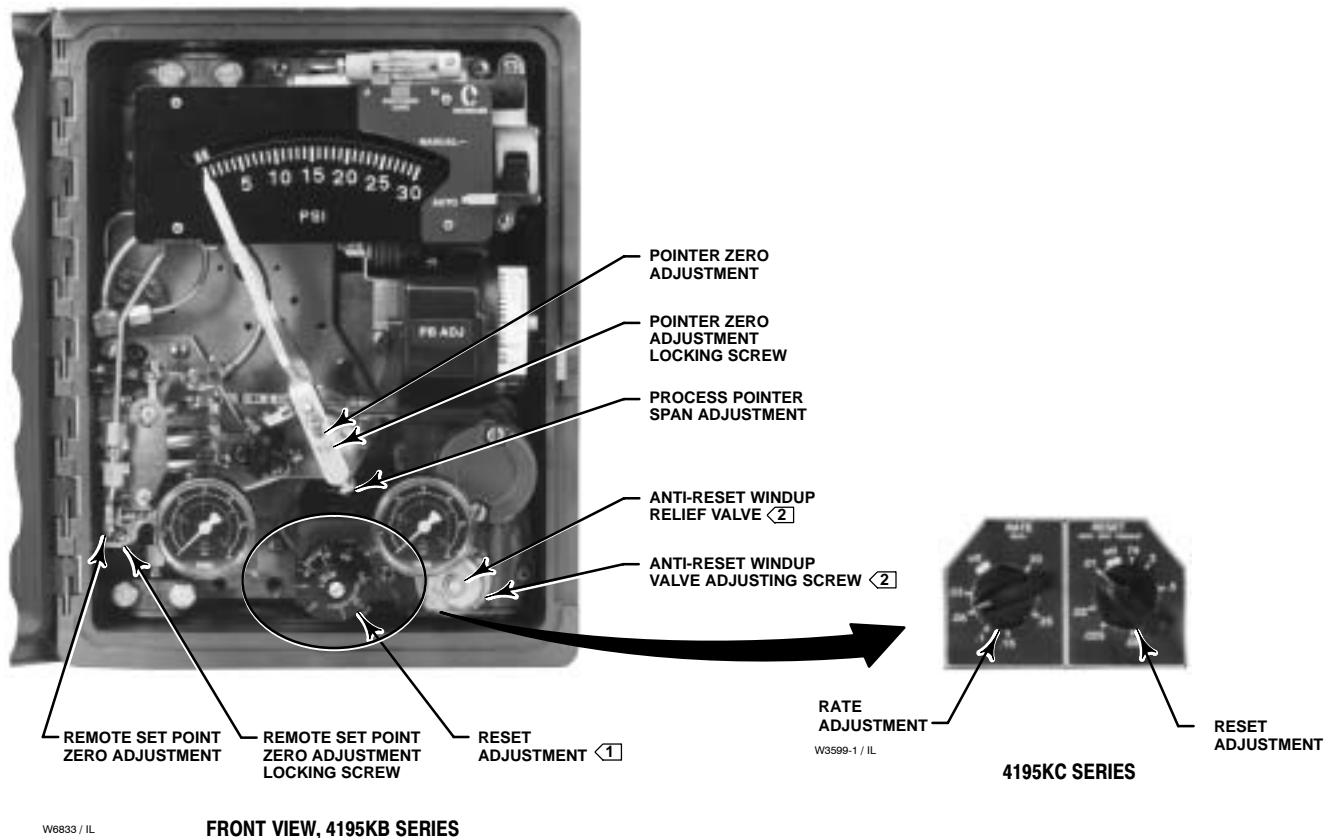

SIDE VIEW OF SET POINT/PROCESS INDICATOR ASSEMBLY

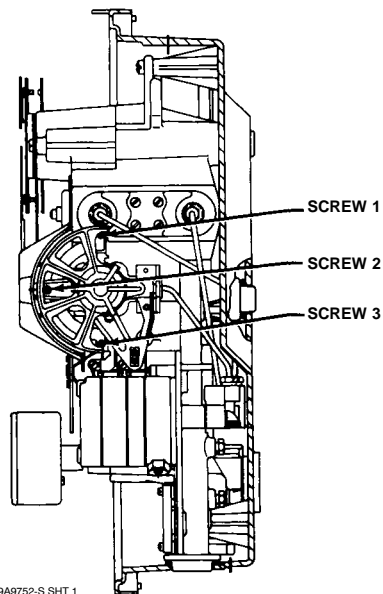

SIDE VIEW OF CONTROLLER SHOWING FLAPPER LEVELING SCREWS

NOTES:

- ① AVAILABLE ON 4195KB SERIES ONLY.
- ② AVAILABLE ON 4195KB AND KC SERIES SUFFIX LETTER F ONLY.

39A1126-B
A8731 / IL

Figure 6-19. 4195K Controller Calibration Adjustment Locations

4195KA, KB, KC, and KS Controllers

5. For a controller with manual set point, move the set point indicator to the mid-scale mark on the process scale. For a controller with remote set point, adjust the remote set point pressure until the set point indicator is at the mid-scale mark on the process scale.
6. Apply process pressure equal to the mid-scale value of the process scale span.
7. The process pointer should be aligned with the pointer subassembly as shown in figure 6-15. If not, loosen the zero adjustment locking screw and adjust the zero adjustment screw to align the process pointer with the pointer subassembly. Tighten the zero adjustment locking screw.
8. The process pointer should indicate mid-scale ± 3 percent of the process scale span. If not, loosen the screws in link 1 and adjust the length so that the process pointer points to the mid-scale mark on the process scale. Tighten the screws.
9. Apply process pressure equal to the process scale lower limit.
10. The process pointer should indicate the process scale lower limit. If not, loosen the zero adjustment locking screw and adjust the zero adjustment screw until the process pointer indicates the lower limit. Tighten the zero adjustment locking screw.
11. Apply process pressure equal to the process scale upper limit.
12. The pointer should indicate the process scale upper limit. If not, proceed as follows:
 - a. If the pointer indicates less than the process scale upper limit, rotate the pointer span adjustment clockwise to increase the span. Adjust the span adjustment screw to correct for half of the error.
 - b. If the pointer indicates greater than the process scale upper limit, rotate the pointer span adjustment counterclockwise to decrease the span. Adjust the span adjustment screw to correct for half of the error.
13. Repeat steps 9 through 12 until the zero and span indications are within ± 1 percent of the scale limits with no further adjustment. If proper span is achieved, proceed to step 15. If the span adjustment screw is adjusted to its limit and the span is still too short or too long, proceed with step 14.
14. Within the process pointer subassembly, there are three holes for the connection of link 1. Use procedure (a.) or (b.) below to make the coarse span adjustment with link 1.
 - a. If the span is short (process pointer indication is less than the process scale upper limit), disconnect link 1 from the process pointer subassembly and move the link to the lowest hole (the hole nearest the pointer pivot). Return to step 9.
 - b. If the span is long, (process pointer indication is greater than the process scale upper limit), disconnect link 1 from the process pointer subassembly and move the link to the highest hole (hole furthest from the pointer pivot), and return to step 9.
15. Apply process pressure equal to the mid-scale value of the process scale span. The process pointer should indicate mid-scale ± 2 percent of the process scale span. If the process pointer error is ± 2 percent or less, proceed to step 17. If the process pointer error is greater than ± 2 percent, loosen the two Bourdon tube mounting screws (key 384, figure 7-2). Also, loosen the two screws (keys 379 and 380, figure 7-2) holding the process tubing retainer.
16. Slide the Bourdon tube up or down and tighten the four screws loosened in step 15. Several tries may be required to determine the direction in which to move the Bourdon tube to obtain the required accuracy. Return to step 5.
17. Adjust the process pointer to within ± 1 percent of the mid-scale mark by loosening the zero adjustment locking screw and adjusting the zero adjustment screw. Tighten the zero adjustment locking screw. This distributes the error over the entire process scale and keeps all points within ± 1 percent of the process scale span.
18. Adjust the process pressure to the lower and upper limits of the process scale span to make sure the process pointer is still within ± 1 percent of the lower and upper scale limits.
19. Perform the flapper alignment procedure and, if necessary, the appropriate remote set point calibration procedure in Section 3, 4, or 5.

Capsular Element Controller Maintenance and Calibration

Replacing the Capsular Element Assembly

WARNING

Refer to the Maintenance **WARNING**
on page 6-1.

Refer to figure 7-5 for key number locations, unless noted otherwise.

1. Remove process pressure from the controller.
2. Note the hole location and disconnect link 1 (key 90) from the process pointer.
3. Disconnect the process pressure connection union (key 93) from the pedestal assembly (key 81). Use two 5/16-inch hex wrenches.
4. Remove the four machine screws (key 127 in figure 7-3) that attach the capsular element assembly to the indicator assembly (key 101 in figure 7-3).

CAUTION

In the following step, do not lift out the capsular element assembly by holding the capsular element or linkages. These parts may be damaged.

5. Lift out the capsular element assembly by holding the tie bar (key 97), mounting plate (key 77), travel stop (key 83), or pedestal assembly (key 81).
6. Position the replacement capsular element assembly over the mounting screw holes. Install and tighten the mounting screws (key 127 in figure 7-3).
7. Reconnect link 1 (key 90) to the process pointer in the same hole noted in step 2.
8. Reconnect the process pressure connection union (key 93).
9. Apply process pressure to the controller and check for leaks.

10. Perform the capsular element maintenance calibration procedure in this section. Perform the controller calibration procedures and, if necessary, the appropriate remote set point calibration procedure in Section 3, 4, or 5.

Replacing Capsular Element Parts

WARNING

Refer to the Maintenance **WARNING**
on page 6-1.

CAUTION

Avoid bending or kinking the drive flexure during the following procedures. Bending or kinking the drive flexure can result in product damage, as well as impaired performance.

Refer to figure 7-5 for capsular element key number locations. Refer to figure 6-19 for adjustment locations and refer to figure 7-4 for indicator assembly (without process sensing element) part locations.

Replacing the Long Pivot Assembly

1. Remove process pressure from the controller.
2. Remove the tie bar (key 97) from the capsular element assembly by removing the mounting screws (key 103).
3. Note the hole position of link 5 (key 88) and disconnect the link from the pivot adjustment arm on the long pivot clevis assembly (key 78).
4. Using an Allen wrench, remove the cap screw and washer (keys 12 and 13) that attach the drive flexure (key 79) to the pivot adjustment arm of the long pivot clevis assembly. Take care not to bend or kink the drive flexure.
5. Remove the two screws (key 102) attaching the long pivot clevis assembly to the mounting plate (key 77).

4195KA, KB, KC, and KS Controllers

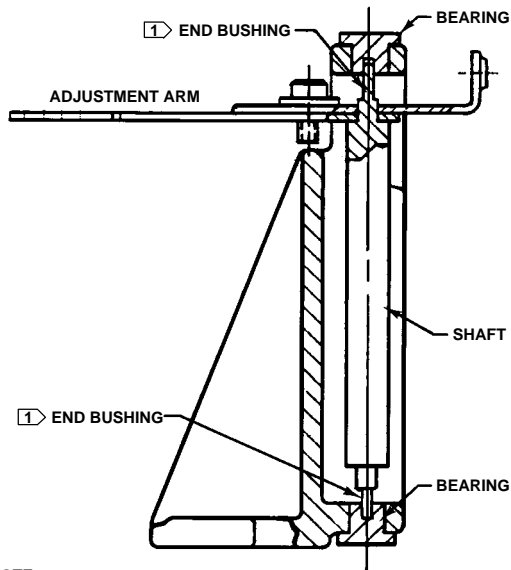

NOTE:
 1 BEFORE TIGHTENING THE DRIVE FLEXURE MOUNTING SCREWS, POSITION THE SHAFT SO THE END BUSHINGS "FLOAT" IN THE BEARINGS.

26A9784-E
 A5682 / IL

Figure 6-20. Cutaway of Long Pivot Clevis Assembly

6. Loosen the screw on the pivot adjustment arm of the replacement pivot clevis assembly, and adjust the arm to the same length as the arm on the pivot assembly being replaced.

7. Attach the replacement pivot clevis assembly to the mounting plate with the two mounting screws (key 102).

8. Loosely connect the drive flexure to the pivot adjustment arm on the new pivot clevis assembly.

See figure 6-20. The adjustment arm of the long pivot clevis assembly is connected to a shaft that turns on bushings at each end of the shaft. In the next step, position the shaft so that both bushings "float" inside the bearings and do not rest against the end of either bearing.

9. Apply 75 percent of the capsular element range to the capsule. The drive flexure should be straight and horizontal. Before tightening the drive flexure cap screws (key 12), hold the pivot shaft in the middle of the bushing end play. Be sure neither bushing is resting against the inside end of either bearing. Tighten the drive flexure cap screws to hold the pivot shaft in position. Adjust the length of the pivot adjustment arm as needed until the drive flexure is horizontal. Take care not to kink or twist the flexure when tightening the screws.

10. Connect the left-hand end of link 5 (key 88) to the pivot adjustment arm in the hole position noted in step 3.

11. Replace the tie bar (key 97).

12. Perform the capsular element maintenance calibration procedure in this section. Perform the controller calibration procedures and, if necessary, perform the appropriate remote set point calibration procedure in Section 3, 4, or 5.

Replacing the Short Pivot Assembly

1. Remove process pressure from the controller.

2. Note the hole positions of links 1 and 5 (keys 88 and 90) and disconnect the links from the short pivot clevis assembly (key 89). Also, note the screw position of the linearity adjustment for later reference.

3. Remove the two machine screws (key 102) attaching the short pivot clevis assembly (key 89) to the mounting plate (key 77) and remove the pivot clevis assembly.

4. Set the linearity adjustment screw in the replacement pivot assembly to approximately the same location as noted in step 2.

5. Position the replacement short pivot clevis assembly on the mounting plate, and attach it with the two machine screws.

6. Attach links 1 and 5 (keys 88 and 90) in the same hole position as noted in step 2.

7. Perform the capsular element maintenance calibration procedures in this section. Perform the controller calibration procedures and, if necessary, the appropriate remote set point calibration procedure in Section 3, 4, or 5.

Replacing the Process Drive Flexure

1. Set the process pressure to 75 percent of the capsular element range.

2. Remove the tie bar (key 97) from the capsular element assembly by removing the mounting screws (key 103).

3. Using an Allen wrench, remove the cap screws and washers (keys 12 and 13) to disconnect the drive flexure (key 79) from the drive bracket assembly (key 84) and from the pivot adjustment arm of the long pivot clevis assembly (key 78). Remove the drive flexure.

4. Loosely connect the replacement drive flexure, making sure it is straight and horizontal.

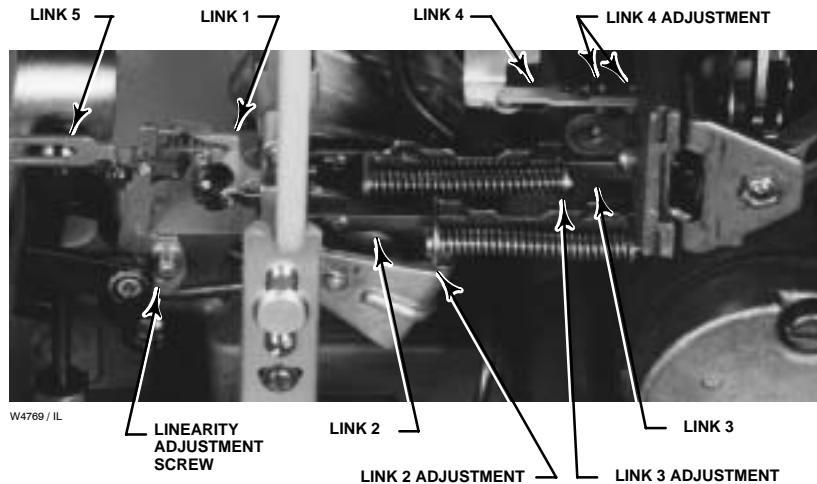

Figure 6-21. Capsular Element Controller Link Locations and Adjustments

Note

See figure 6-20. The adjustment arm of the long pivot clevis assembly is connected to a shaft that turns on bushings at each end of the shaft. In the next step, position the shaft so that both bushings “float” inside the bearings and do not rest against the end of either bearing.

5. Before tightening the drive flexure cap screws (key 12), hold the pivot shaft in the middle of the bushing end play. Be sure neither bushing is resting against the inside end of either bearing. Tighten the drive flexure cap screws to hold the pivot shaft in position. Take care not to kink or twist the flexure when tightening the screws.
6. Perform the capsular element maintenance calibration procedure in this section. Perform the controller calibration procedures and, if necessary, the appropriate remote set point calibration procedure in Section 3, 4, or 5.

Replacing the Process Tubing

1. Remove process pressure from the controller.
2. Using two open-end 5/16-inch wrenches, disconnect the process tubing (keys 91 or 92) at the pedestal assembly (key 81) and at the bottom of the controller case. Remove the tubing.
3. Install the replacement tubing, and tighten all connections. Check for leaks.
4. Perform the controller calibration procedures and, if necessary, the appropriate remote set point calibration procedure in Section 3, 4, or 5.

Replacing Capsular Element Controller Links

WARNING

Refer to the Maintenance **WARNING** on page 6-1.

This section describes the separate replacement of five links in the controller. Figure 6-21 shows the location of each link. To clarify the location of each link, the links are numbered as follows:

- Link 1 connects the short pivot clevis assembly and the process pointer
- Link 2 connects the process pointer and the flapper assembly (key 11)
- Link 3 connects the set point indicator and the set point beam assembly (key 23)
- Link 4 (key 65) connects the flapper assembly and the bellows bracket (key 31)
- Link 5 (key 88 in figure 7-5) connects the short pivot clevis assembly (key 89) and the long pivot clevis assembly (key 78).

4195KA, KB, KC, and KS Controllers

Replacing Capsular Element Controller Link 1

1. Remove the two screws (key 6), and lift off the proportional band indicator cover (key 36).
2. Note the hole position of link 1 and disconnect the link from the short pivot clevis assembly and from the process pointer. Remove the link.
3. Attach the replacement link in the same holes noted in step 2 to the process pointer and the short pivot clevis assembly. If you do not know in which hole in the process pointer the link was connected, place it in the middle hole. If during the process indicator zero and span calibration, the pointer will not travel the full scale, even after full span adjustment, move the link to the bottom hole (the hole nearest the pointer pivot). If the process pointer has too much travel, move the link to the top hole (the hole furthest from the pointer pivot).
4. Move the set point indicator, either manually or with remote set point pressure, to the mid-scale mark on the process scale and set the proportional band between DIRECT and REVERSE.
5. The process pointer should be aligned with the pointer subassembly as shown in figure 6-15. If not, loosen the zero adjustment locking screw and adjust the process pointer zero adjustment to align the process pointer and pointer subassembly. Tighten the zero adjustment locking screw.
6. Apply process pressure equal to the mid-scale value of the process scale span. The process pointer should indicate mid-scale ± 3 percent of the process scale span. If not, loosen the screw in link 1 or link 5, and move the pointer to the mid-scale mark on the process scale. Tighten the screw.
7. Perform the controller calibration procedures and, if necessary, the appropriate remote set point calibration procedure in Section 3, 4, or 5.

Replacing Capsular Element Controller Link 2

1. Remove the two screws (key 6), and lift off the proportional band indicator cover (key 36).
2. Disconnect link 2 from the process pointer and from the flapper assembly (key 11). Remove the link.
3. Install the replacement link with the screw head nearest the process pointer as shown in figure 6-21. Connect the link to the process pointer only.
4. The process pointer should be lined up with the pointer subassembly as shown in figure 6-15. If not, loosen the zero adjustment locking screw and adjust the process pointer zero adjustment to align the

pointer with the process pointer subassembly. Tighten the zero adjustment locking screw.

5. Move the set point indicator, manually or with remote set point pressure, to the process scale lower limit and set the proportional band at 5 percent REVERSE. The nozzle should not be touching the flapper. If it is, adjust flapper leveling screw 1 (the screw nearest the nozzle) until clearance is obtained.
6. Note the hole position and disconnect link 1 from the short pivot clevis assembly. Manually position the process pointer to the process scale upper limit and tape the process pointer in this position.
7. Adjust the length of link 2 (by turning the adjusting screw clockwise to increase the length or counterclockwise to decrease the length) so that the pin on the end of the link is approximately one-half of its diameter short of aligning with the hole in the flapper assembly as shown in figure 6-11. This adjustment provides the proper tension on the link to eliminate lost motion.
8. Connect link 2 to the flapper assembly.
9. Remove the tape from the process pointer and reconnect link 1 to the hole in the short pivot clevis assembly noted in step 6.
10. Perform the controller calibration procedures and, if necessary, the appropriate remote set point calibration procedure in Section 3, 4, or 5.

Replacing Capsular Element Controller Link 3

1. Remove the two screws (key 6), and lift off the proportional band indicator cover (key 36).
2. Disconnect link 3 from the set point indicator and the set point beam assembly (key 23).
3. Adjust the replacement link to the same length as the link removed.
4. Install the replacement link with the screw head toward the set point beam assembly as shown in figure 6-21.
5. Check that the set point beam bias spring (key 28) is correctly located in the frame bore and the spring seat on the set point beam assembly as shown in figure 6-3.
6. Move the set point indicator to the mid-scale mark on the process scale.
7. Apply process pressure to position the process pointer at the mid-scale mark on the process scale.
8. Adjust the proportional band to 5 percent DIRECT. Turn flapper leveling screw 3 (the screw nearest the nozzle) until the nozzle just touches the flapper.

9. Adjust the proportional band to 5 percent REVERSE. Turn flapper leveling screw 1 (the screw nearest the nozzle) until the nozzle just touches the flapper.

10. Flapper leveling screws 1 and 3 should protrude the same distance from the clinch nuts. A clinch nut is shown in figure 6-16.

11. If leveling screw 1 protrudes further than leveling screw 3, turn the link 3 adjusting screw counterclockwise. If leveling screw 3 protrudes further than leveling screw 1, turn the link 3 adjusting screw clockwise.

12. Repeat steps 8 through 11 until leveling screws 1 and 3 protrude an equal distance from the clinch nuts.

13. Perform the controller calibration procedures and, if necessary, the appropriate remote set point calibration procedure in Section 3, 4, or 5.

Replacing Capsular Element Controller Link 4

1. Remove the two screws (key 6), and lift off the proportional band indicator cover (key 36).

2. Disconnect link 4 from the bellows bracket (key 31) and the flapper assembly (key 11).

3. Connect the replacement link to the flapper assembly so that the two adjusting screws on the link are nearest to the bellows bracket (key 31) and so that the screw heads are facing the bottom of the controller as shown in figure 6-21.

4. For controllers with reset (4195KB Series) or reset and rate adjustments (4195KC Series), turn the reset adjustment to the CLOSED (4195KB) or OFF (4195KC) position. Turn the rate adjustment (4195KC Series) to the OFF position.

The controller output must be 0 bar (0 psig). To be sure the controller output is at 0 bar (0 psig), remove supply pressure, set the reset adjustment to 0.01 minutes per repeat and wait 30 seconds; then, turn the reset adjustment to the CLOSED (4195KB) or OFF (4195KC) position.

5. Adjust the proportional band to 5 percent REVERSE and move the set point indicator to the process scale upper limit.

6. Disconnect link 1 from the pivot arm. Tape the process pointer to the process scale lower limit (the last mark on the left side of the scale).

7. Apply the correct supply pressure to the controller. The output of the controller should be within 0.14 bar (2 psig) of supply pressure. If not, adjust flapper leveling screw 1 (the screw nearest

the nozzle) until the output is within 0.14 bar (2 psig) of supply pressure.

8. Loosen the two adjusting screws on link 4. Connect the free end of the link to the bellows bracket and allow the link to find its free length.

9. Tighten the two adjusting screws on the link.

10. Raise link 4 out of the hole in the bellows bracket (key 31) and ensure that it drops back into the hole under its own weight. If not, repeat steps 8 and 9.

11. For a controller with reset, adjust the reset adjustment to 0.01 minutes per repeat. The rate adjustment (4195KC) should remain in the OFF position.

12. The controller output should be within 0.14 bar (2 psig) of the supply pressure. If not, adjust flapper leveling screw 1 (the screw nearest the nozzle) until the output is within 0.14 bar (2 psig) of supply pressure.

13. Remove the tape from the process pointer and connect link 1 to the pivot arm.

14. Perform the controller calibration procedures and, if necessary, the appropriate remote set point calibration procedure in Section 3, 4, or 5.

Replacing Capsular Element Controller Link 5

1. Remove the two screws (key 6), and lift off the proportional band indicator cover (key 36).

2. Note the location of the connection holes and disconnect both ends of link 5 (key 88) from the lever arms of the two pivot assemblies. Refer to figure 6-22 for parts locations.

3. Loosen the adjustment screw on the replacement link and adjust the length to match the original link. Tighten the adjustment screw.

4. Attach the replacement link to the two lever arms in the same holes noted in step 2.

5. Move the set point indicator, either manually or with remote set point pressure, to the mid-scale mark on the process scale and set the proportional band between DIRECT and REVERSE.

6. The process pointer should be aligned with the pointer subassembly as shown in figure 6-15. If not, loosen the zero adjustment locking screw and adjust the process pointer zero adjustment to align the process pointer and pointer subassembly. Tighten the zero adjustment locking screw.

7. Apply process pressure equal to the mid-scale value of the process scale span. The process pointer should indicate the mid-scale ± 3 percent of the scale span. If not, loosen the screw in link 1 or

4195KA, KB, KC, and KS Controllers

link 5, and move the process pointer to the mid-scale mark of the process scale span. Tighten the screw.

8. Perform the controller calibration procedures and, if necessary, the appropriate remote set point calibration procedure in Section 3, 4, or 5.

Capsular Element Controller Maintenance Calibration



WARNING

Refer to the Maintenance WARNING on page 6-1.

Precalibration Procedure

1. Remove the two machine screws (key 6) and lift off the proportional band indicator cover (key 36).
2. Set the proportional band adjustment between DIRECT and REVERSE.
3. Remove the two screws (key 103) and remove the tie bar (key 97) from the capsular element assembly.

Aligning the Drive Bracket Assembly

Refer to figures 6-22 and 7-5.

1. With an Allen wrench, loosen the set screw in the hex nut of the drive bracket assembly (key 84).
2. Loosen the screw (key 98) that holds the guide flexure to the tab on the mounting plate (key 77). The guide flexure location is shown in figure 6-22.
3. Apply process pressure equal to 75 percent of the capsular element range.
4. Slide the drive bracket assembly (key 84) along the diaphragm capsule extension (key 82) until the guide flexure is aligned with the center of the long pivot clevis assembly (key 78).
5. Tighten the machine screw (key 98) and the set screw in the hex nut to fasten the drive bracket assembly in that position.

Setting the Capsular Element Travel Stops

1. **For the full span stop**—Apply process pressure equal to 5 percent greater than capsular element range. Then perform the following as appropriate:

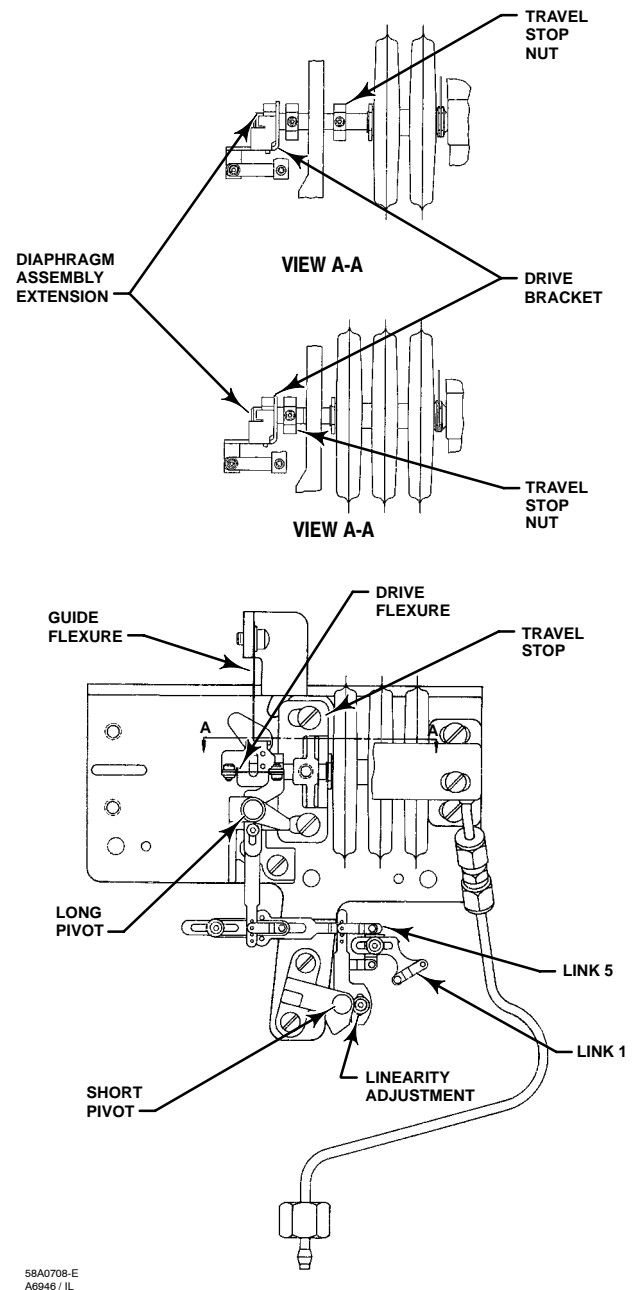

Figure 6-22. Process Input Capsular Element Assembly Part and Adjustment Locations (Positive and Compound Pressure Element Shown)

- For positive or compound pressure with a three-capsule stack, loosen the machine screws (key 139) that secure the travel stop (key 83) to the mounting plate (key 77). Slide the travel stop until it is just touching the end of the capsule stack. Tighten the travel stop mounting screws to lock it into position. Decrease the input pressure to 100 percent of the capsular element range and make sure the capsule stack is not contacting the travel stop (key 83).

- For positive or compound pressure with a two-capsule stack, loosen the set screw (key 87) in the travel stop nut (key 86) between the travel stop (key 83) and the capsule stack. Slide the nut along the diaphragm capsule extension (key 130) until it just touches the travel stop (key 83). Tighten the set screw to lock the travel stop nut in position. Decrease the input pressure to 100 percent of the capsular element range and make sure the travel stop nut is not contacting the travel stop (key 83).

- For vacuum pressure, loosen the set screw (key 87) in the travel stop nut (key 86) on the end of the diaphragm capsule extension (key 132 or 133). The nut is located on the opposite side of the travel stop (key 83) from the capsule. Slide the nut along the diaphragm capsule extension until it just touches the travel stop (key 83). Tighten the set screw to lock the travel stop nut in position. Decrease the vacuum to 100 percent of the capsular element range and make sure the travel stop nut is not contacting the travel stop (key 83).

2. **For the zero stop**—perform the following as appropriate:

- If the lower limit of the capsular element range is 0 bar (0 psig), adjust the process pressure to 0 bar (0 psig). Slide the zero travel stop nut (key 86) along the diaphragm assembly extension until it is approximately 0.4 mm (1/64-inch) away from the travel stop. Tighten the set screw to lock the travel stop nut in position.

- If the lower limit of the capsular element range is other than 0 bar (0 psig), adjust the process pressure to 5 percent below the capsular element range lower limit and slide the travel stop nut (key 86) along the diaphragm extension until it just touches the travel stop (key 83). Tighten the set screw. Increase the input pressure to the capsular element range lower limit and make sure the travel stop nut is not contacting the travel stop (key 83).

Aligning the Capsular Element Linkage

1. Adjust the process pressure to 75 percent of the capsular element range. The drive flexure (key 79) should be straight and horizontal. If it is not, proceed as follows:

- a. Loosen the screw on the pivot adjustment arm on the long pivot clevis assembly (key 78) and the two screws mounting the drive flexure.

- b. Adjust the length of the pivot adjustment arm so that the drive flexure is parallel to the centerline of the capsules. Tighten the screw to set the length of the pivot adjustment arm in that position.

Note

See figure 6-20. The adjustment arm of the long pivot clevis assembly is connected to a shaft that turns on bushings at each end of the shaft. In the next step, position the shaft so that both bushings “float” inside the bearings and do not rest against the end of either bearing.

- c. Before retightening the drive flexure screws, hold the long pivot clevis assembly shaft in the middle of the bushing end play. Be sure neither bushing is resting against the inside end of either bearing.

- d. Tighten the drive flexure screws to hold the pivot clevis assembly shaft in position.

2. Set the linearity adjustment screw on the short pivot clevis assembly so the two arms of the short pivot clevis assembly are parallel. The linearity adjustment screw should be near the center of its slot.

3. Make certain that the process pointer and pointer subassembly are aligned as shown in figure 6-15. If not, loosen the zero adjustment locking screw and adjust the process pointer zero adjustment screw to align the process pointer and pointer subassembly. Tighten the zero adjustment locking screw.

4. Adjust the process pressure to 50 percent of the capsular element range.

5. Loosen the screw on link 5 (key 88) and adjust the link length so that the pivot arms of the short pivot clevis assembly (key 89) and the long pivot clevis assembly (key 78) are parallel. Tighten the screw.

6. Complete the maintenance calibration by performing the zero and span adjustments in the following procedure.

4195KA, KB, KC, and KS Controllers

Capsular Element Controller Zero and Span Adjustment

Note

For routine zero and span calibration, refer to the appropriate procedures in Section 3, 4, or 5. Use the following maintenance zero and span adjustment procedure only if difficulty is encountered with the routine procedure or if nonlinearity occurs.

Provide a means of applying process pressure to the sensing element and a regulated supply pressure adjusted to the normal operating pressure (see table 1-6). Plug the controller output or connect it to a gauge. Monitoring the controller output is not necessary. However, the flapper should not contact the nozzle at any time while performing this procedure. If it does, adjust flapper screw 2 (the one nearest the nozzle) to provide clearance. Refer to figure 6-19 for the adjustment locations. Refer to figure 7-1 for the key number locations.

Note

Any adjustment of the process pointer span adjustment screw requires readjustment of the process pointer zero adjustment screw.

1. Remove the two machine screws (key 6) and lift off the proportional band indicator cover (key 36).
2. Set the proportional band between DIRECT and REVERSE.
3. Adjust the reset (4195KB and KC Series only) to 0.01 minutes per repeat.
4. Adjust the rate (4195KC Series only) to OFF.
5. For a controller with manual set point, move the set point indicator to the mid-scale mark on the process scale. For a controller with remote set point, adjust the remote set point pressure until the set point indicator is at the mid-scale mark on the process scale.
6. Apply process pressure equal to the mid-scale value of the process scale span.
7. The process pointer should be aligned with the pointer subassembly as shown in figure 6-15. If not, loosen the zero adjustment locking screw and adjust the zero adjustment screw to align the process pointer with the pointer subassembly. Tighten the zero adjustment locking screw.

8. The process pointer should indicate mid-scale ± 3 percent of the process scale span. If not, loosen the screw on either link 1 or link 5 and adjust the length so that the process pointer points to the mid-scale mark on the process scale. Tighten the screw.

9. Apply process pressure equal to the process scale lower limit.

10. The process pointer should indicate the process scale lower limit. If not, loosen the zero adjustment locking screw and adjust the zero adjustment screw until the process pointer indicates the lower limit. Tighten the zero adjustment locking screw.

11. Apply process pressure equal to the process scale upper limit.

12. The process pointer should indicate the process scale upper limit. If not, proceed as follows:

a. If the pointer indicates less than the process scale upper limit, rotate the pointer span adjustment clockwise to increase the span. Adjust the span adjustment screw to correct for one-half of the error.

b. If the pointer indicates greater than the process scale upper limit, rotate the pointer span adjustment counterclockwise to decrease the span. Adjust the span adjustment screw to correct for one-half of the error.

13. Repeat steps 9 through 12 until the zero and span indications are within ± 1 percent of the scale limits with no further adjustment. If proper span is achieved, proceed to step 16. If the span adjustment screw is adjusted to its limit and the span is still too short or too long, proceed with step 14.

14. Within the process pointer subassembly, there are three holes for the connection of link 1. Use procedure (a.) or (b.) below to make the coarse span adjustment with link 1.

a. If the span is short (process pointer indication is less than the process scale upper limit), disconnect link 1 from the process pointer subassembly, move the link to the lowest hole (the hole nearest the pointer pivot), and return to step 9. If the link is already in the lowest hole, proceed to step 15.

b. If the span is long, (process pointer indication is greater than the process scale upper limit), disconnect link 1 from the process pointer subassembly, move the link to the highest hole (the hole furthest from the pointer pivot), and return to step 9. If the link is already in the highest hole, proceed to step 15.

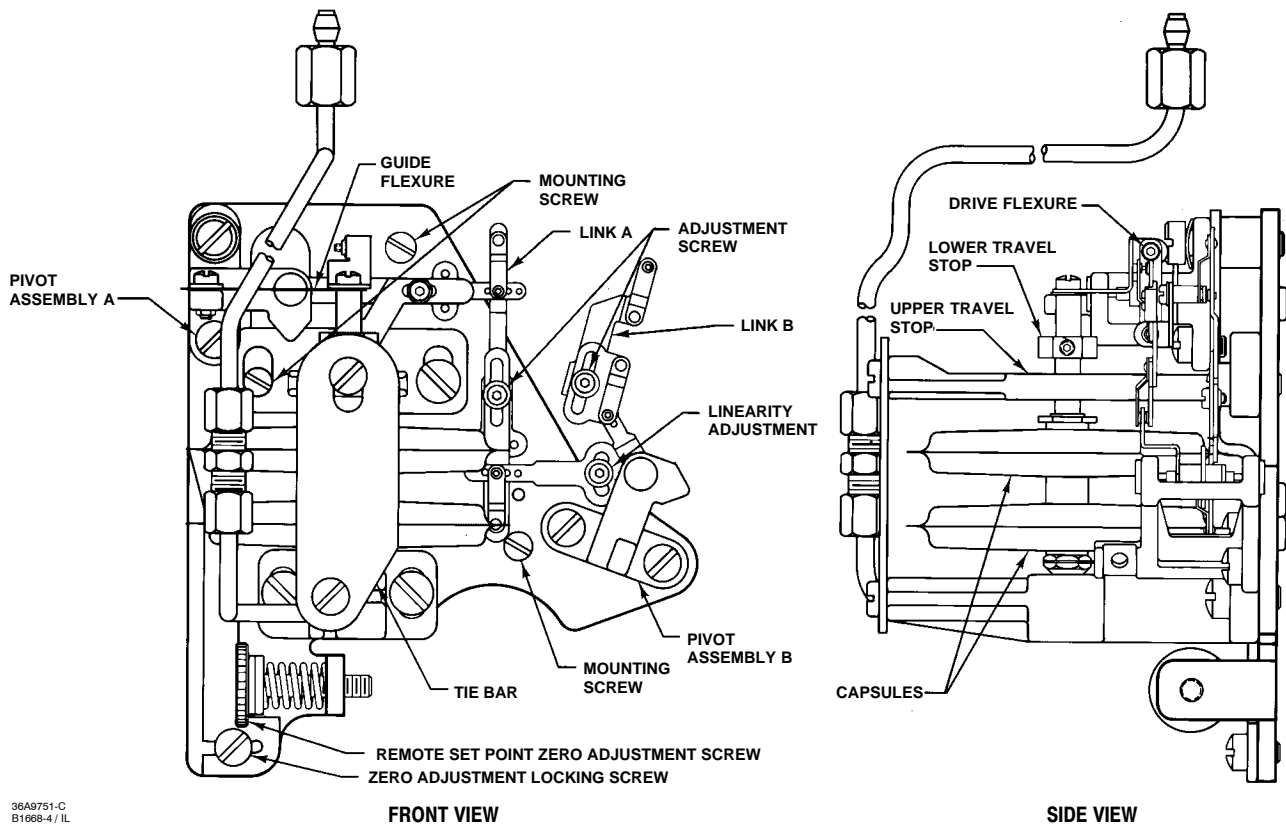

Figure 6-23. Remote Set Point (suffix letter M) Parts and Adjustment Locations

15. At either end of link 5, there are four holes in which the link may be connected. A coarse span adjustment can be made by moving both ends of link 5 up or down.

a. If the span is short (process pointer indication is less than the process scale upper limit), disconnect both ends of link 5, move the link down one set of holes, and return to step 6.

b. If the span is long (process pointer indication is greater than the process scale upper limit), disconnect both ends of link 5, move the link up one set of holes, and return to step 6.

16. Apply process pressure equal to the mid-scale value of the process scale span. The process pointer should indicate mid-scale ± 2 percent of the scale span. If the process pointer error is ± 2 percent or less, proceed to step 17. If the process pointer error exceeds ± 2 percent, the linearity can be

improved with the linearity adjustment. See figure 6-22 for the linearity adjustment screw location.

a. If the error at mid-scale is high (process pointer is to the right side of the mid-scale mark), loosen the linearity adjustment screw and slide it upward in the curved slot. Tighten the screw and return to step 6.

b. If the error at mid-scale is low (process pointer is to the left side of the mid-scale mark), loosen the linearity adjustment screw and slide it downward in the curved slot. Tighten the screw and return to step 6.

17. Adjust the process pointer to within ± 1 percent of the mid-scale mark by loosening the zero adjustment locking screw and adjusting the zero adjustment locking screw. Tighten the zero adjustment locking screw. This distributes the error over the entire process scale and keeps all points within ± 1 percent of the process scale span.

4195KA, KB, KC, and KS Controllers

18. Adjust the process pressure to the lower and upper limits of the scale span to make sure the process pointer is still within ± 1 percent of the lower and upper scale limits.

19. Perform the flapper alignment procedure and, if necessary, the appropriate remote set point calibration procedure in Section 3, 4, or 5.

Remote Set Point (suffix letter M) Maintenance

Replacing the Remote Set Point Assembly



WARNING

Refer to the Maintenance **WARNING** on page 6-1.

Use the following procedures to replace the remote set point assembly. Figure 6-23 shows the part locations. Refer to figure 7-6 for key number locations.

Note

Remove the supply pressure gauge before attempting to remove the capsular element assembly.

1. Decrease the remote set point pressure to 0 bar (0 psig).
2. Remove the supply pressure gauge.
3. Remove the pressure connection (key 93) at the pedestal assembly (key 105). Use two 5/16 inch wrenches.
4. Disconnect link B (key 126) from the connection hole on the set point indicator.
5. Remove the three mounting screws (keys 120 and 140) that attach the remote set point assembly to the process/set point indicator assembly. Figure 6-23 shows the mounting screw locations.

CAUTION

In the following step, do not lift out the remote set point assembly by holding the capsular element or linkages. These parts may be damaged.

6. Lift out the remote set point assembly by holding the tie bar (key 106), mounting plate (key 111), travel stop (key 83), or pedestal assembly (key 105).
7. Align the replacement assembly with the mounting screw holes. Replace the mounting screws.
8. Reconnect the remote set point pressure connection union (key 93). Apply full remote set point pressure and check for leaks.
9. Connect link B (key 126) to the connecting hole on the set point indicator.
10. Replace the supply pressure gauge.
11. Perform the remote set point maintenance calibration procedure. Perform the appropriate process indicator zero and span calibration and flapper alignment procedure in Section 3, 4, or 5.

Replacing Remote Set Point Assembly Parts



WARNING

Refer to the Maintenance **WARNING** on page 6-1.

CAUTION

Avoid bending or kinking the drive flexure during the following procedures. Bending or kinking the drive flexure can result in product damage, as well as impaired performance.

Figure 6-23 shows the parts and adjustment locations. Refer to figure 7-6 for key number locations.

Replacing Pivot Assembly A (Key 114)

1. Decrease the remote set point pressure to 0 bar (0 psig).
2. Remove the two screws (key 103) and remove the tie bar (key 106).

3. Note where link A is connected. Disconnect link A (key 116) from the lever arm on pivot assembly A (key 114).
4. Disconnect the drive flexure (key 79) from the adjustment arm of pivot assembly A. Be careful not to bend or kink the drive flexure.
5. Remove the screw (key 122), washer (key 123), and nut (key 124) that attach the guide flexure (key 119) to the top of the pivot assembly.
6. Remove the pivot screw and spring washer (keys 109 and 112) and the mounting screw (key 102) attaching the pivot assembly to the mounting plate (key 111). Lift out pivot assembly A.
7. Loosen the adjustment screw (key 118) on the adjustment arm of the replacement pivot assembly, and set the arm to the same length as the arm on the pivot assembly being replaced. Tighten the screw.
8. To replace the pivot assembly, first put the spring washer (key 112) on the screw (key 109). Then, insert the screw through the replacement pivot assembly and into the mounting plate and tighten. Install the mounting screw (key 102) and tighten.
9. Connect the guide flexure (key 119) to the top of the replacement pivot assembly with the screw (key 122), washer (key 123), and nut (key 124) as it was before. The guide flexure should be straight and horizontal as shown in figure 6-23. If not, loosen the screws (key 122) and retighten to eliminate any bowing. Loosen the screws (key 139) and raise or lower the pedestal assembly (key 105) to get the link horizontal. Retighten the screws (key 139) and ensure the diaphragm assembly extension (key 134) is centered in the upper travel stop (key 83) hole.
10. Apply remote set point pressure equal to 50 percent of the remote set point input range.

Note

See figure 6-20. The adjustment arm of the remote set point pivot assembly A turns on a bushing at each end of the shaft supporting the adjustment arm. In the next step, position the shaft so both bushings “float” inside the bearings and do not rest against the end of either bearing.

11. Connect the drive flexure (key 79) to the arm on the replacement pivot assembly, making sure it stays straight and vertical. Adjust the length of the pivot arm, if necessary, until the flexure is vertical.

Before tightening the drive flexure screws, hold the pivot assembly shaft in the middle of the bushing end play. Be sure neither bushing is resting against the inside end of either bearing. Tighten the drive flexure screws to hold pivot assembly A in this position. Do not bend or twist the flexure when tightening the screws.

12. Decrease the remote set point pressure to 0 bar (0 psig).
13. Connect the end of link A (key 116) to the pivot lever arm in the same holes noted in step 3.
14. Replace the tie bar (key 106).
15. Perform the remote set point maintenance calibration procedure. Perform the appropriate process indicator zero and span calibration and flapper alignment procedures in Section 3, 4, or 5.

Replacing Pivot Assembly B (Key 115)

1. Decrease the remote set point pressure to 0 bar (0 psig).
2. Note the holes where links A and B are connected. Disconnect links A and B (keys 116 and 126) from the arms of pivot assembly B (key 115).
3. Remove the two screws (key 102) that attach pivot assembly B to the mounting plate (key 111). Remove the pivot assembly.
4. Loosen the linearity adjustment screw on the replacement pivot assembly and set it in the same position as the adjustment on the original pivot assembly. Tighten the screw.
5. Set the replacement pivot assembly on the mounting plate, and attach it with the two machine screws.
6. Attach links A and B (keys 116 and 126) to the arms of the replacement pivot assembly in the same holes noted in step 2.
7. Perform the remote set point maintenance calibration procedure. Perform the appropriate process indicator zero and span calibration and flapper alignment procedures in Section 3, 4, or 5.

Replacing the Drive Flexure

1. Using an Allen wrench, remove the cap screws (key 12) and washers (key 13) to disconnect the drive flexure (key 79) from the drive bracket (key 121) and from the adjustment arm of pivot assembly A. Remove the drive flexure.
2. Set the remote set point pressure to 50 percent of the remote set point input range.

4195KA, KB, KC, and KS Controllers

Note

See figure 6-20. The adjustment arm of the remote set point pivot assembly A turns on a bushing at each end of the shaft supporting the adjustment arm. In the next step, position the shaft so both bushings “float” inside the bearings and do not rest against the end of either bearing.

3. Connect the new drive flexure making sure it stays straight and vertical. Adjust the length of the pivot arm, if necessary, until the drive flexure is straight. Before tightening the drive flexure screws, hold the pivot assembly A shaft in the middle of the bushing end play. Be sure neither bushing is resting against the inside end of either bearing. Tighten the drive flexure screws to hold the pivot shaft in this position. Do not bend or twist the flexure when tightening the screws.
4. Decrease the remote set point pressure to 0 bar (0 psig).
5. Perform the remote set point maintenance calibration procedure. Perform the appropriate process indicator zero and span calibration and flapper alignment procedure in Section 3, 4, or 5.

Replacing the Remote Set Point Tubing

1. Decrease the remote set point pressure to 0 bar (0 psig).
2. Using two 5/16-inch open-end wrenches, disconnect the pressure connection union (key 93) from the pedestal assembly (key 105) and the connection to the case exterior at the top of the case.
3. Remove the tubing (key 104).
4. Install the replacement tubing, and reconnect the two pressure connections.
5. Apply full remote set point pressure, and check for leaks.

Replacing Link A

This procedure describes link A (key 116) replacement in the remote set point assembly. Figure 6-23 shows the link location.

1. Note the holes where link A is connected. Disconnect link A (key 116) from the lever arms on pivot assembly A and pivot assembly B.

2. Loosen the screw in the replacement link A and adjust the length to match the link being replaced. Tighten the screw.
3. Refer to figure 6-23 for the correct link orientation. Attach the replacement link A to the two lever arms in the same holes noted in step 1.
4. Perform the remote set point maintenance calibration procedure. Perform the appropriate process indicator zero and span calibration and flapper alignment procedures in Section 3, 4, or 5.

Replacing Link B

This procedure describes link B (key 126) replacement in the remote set point assembly. Figure 6-23 shows the link location.

1. Note the holes where link B is connected. Disconnect link B (key 126) from the pivot arm and from the set point indicator.
2. Loosen the screw in the replacement link B and adjust the length to match the link being replaced. Tighten the screw.
3. Refer to figure 6-23 for the correct link orientation. Attach the replacement link B to the pivot arm and to the set point indicator in the same holes as noted in step 1.
4. Perform the remote set point maintenance calibration procedure. Perform the appropriate process indicator zero and span calibration and flapper alignment procedures in Section 3, 4, or 5.

Remote Set Point (suffix letter M) Maintenance Calibration

Refer to figure 6-23 for parts and adjustment locations. Refer to figures 7-1 and 7-6 for key number locations.

Precalibration Procedure



Refer to the Maintenance WARNING on page 6-1.

1. Remove the two screws (key 6) and lift off the proportional band indicator cover (key 36).
2. Set the proportional band adjustment between DIRECT and REVERSE.
3. Remove the two screws (key 103) and remove the tie bar (key 106) from the remote set point assembly.

Aligning the Flexures

WARNING

Refer to the Maintenance WARNING on page 6-1.

1. Apply remote set point pressure equal to 50 percent of the remote set point pressure range.
2. The guide flexure (key 119) should be straight and horizontal. If not, straighten the flexure by loosening the machine screw (key 122) on the end of the flexure that is attached to the top of the pivot assembly A (key 114) and allow the flexure to straighten itself. Tighten the machine screw.
3. If the flexure is not horizontal, loosen the two machine screws (key 139) and raise or lower the pedestal assembly (key 105) until the guide flexure is horizontal. Retighten the machine screws (key 139) and ensure the diaphragm assembly extension (key 134) is centered in the upper travel stop (key 83) hole.
4. The drive flexure (key 79) should be straight. If not, proceed as follows:
 - a. Loosen the screw (key 118) on the adjustment arm of pivot assembly A (key 114) and loosen the screws holding the drive flexure.
 - b. Set the length of the adjustment arm so that the drive flexure is parallel to the centerline of the diaphragm capsule assembly (key 80).
 - c. Tighten the screw (key 118) on the adjustment arm.

Note

See figure 6-20. The adjustment arm of the remote set point pivot assembly A turns on a bushing at each end of the shaft supporting the adjustment arm. In the next step, position the shaft so both bushings “float” inside the bearings and do not rest against the end of either bearing.

- d. Hold the pivot assembly A shaft in the middle of the bushing end play. Be sure neither bushing is resting against the inside end of either bearing.
- e. Tighten the screws that hold the drive flexure in place.

Setting the Travel Stops

WARNING

Refer to the Maintenance WARNING on page 6-1.

1. Loosen the set screw (key 87) in the travel stop nut (key 86).

CAUTION

Make sure the loose travel stop nut does not bind on the diaphragm capsule extension (key 134) when pressurizing the capsules (key 80). Damage to the capsules may result.

2. **Full span stop**—Adjust the remote set point pressure to 2-1/2 percent of span greater than the remote set point input range upper limit.

Loosen the two screws (keys 139 and 140) that secure the travel stop (key 83) to the mounting plate (key 111). Slide the travel stop until it is just touching the end of the capsule stack. Tighten the travel stop mounting screws to lock it into position.

3. **Zero Stop**—Adjust the remote set point pressure to 2-1/2 percent of span less than the remote set point input range lower limit.

Slide the travel stop nut (key 86), along the diaphragm capsule extension (key 134) until it is just touching the travel stop (key 83). Tighten the set screw (key 87) to lock the travel stop nut in position.

Aligning the Linkage

WARNING

Refer to the Maintenance WARNING on page 6-1.

1. Adjust the remote set point pressure to 50 percent of the remote set point input range.
2. Set the linearity adjustment screw in the center of the slot on the lever arm of pivot clevis assembly B (key 115). See figure 6-23 for the linearity adjustment location.
3. Set the length of link A (key 116) so the lever arms of pivot assembly A and pivot assembly B are parallel and link A is perpendicular to them.
4. Set the length of link B (key 126) so the set point indicator indicates mid-scale on the process scale span.

4195KA, KB, KC, and KS Controllers

5. Replace the tie bar (key 106) and install the two screws (key 103).

Remote Set Point Zero and Span Adjustment



WARNING

Refer to the Maintenance WARNING on page 6-1.

Note

For routine remote set point zero and span calibration, refer to the appropriate procedures in Section 3, 4, or 5. Use the following maintenance remote set point zero and span adjustment procedures only if difficulty is encountered with the routine procedure or nonlinearity occurs.

Refer to figures 6-19 and 6-23 for adjustment locations.

1. Decrease the remote set point pressure to 0 percent of the remote set point input range.
2. The set point indicator should indicate the lower limit of the process scale span. If not, loosen the adjustment screw on link A (key 116), and adjust the length so the set point indicator points to the lower limit of the process scale. Tighten the screw.
3. Make fine zero adjustments by loosening the zero adjustment locking screw (key 102) and turning the zero adjustment screw (key 108). Tighten the locking screw. Refer to figure 6-23 for the screw locations.
4. Apply remote set point pressure equal to 100 percent of the remote set point input range.
5. The set point indicator should indicate the upper limit of the process scale span.
6. To increase the span, proceed as follows:
 - a. Turn the remote set point span adjustment screw clockwise.
 - b. To increase the span further than the adjustment screw allows, move both ends of link A (key 116) to the right.
 - c. Make fine adjustments with the remote set point span adjustment screw.
7. To decrease the span, proceed as follows:
 - a. Turn the remote set point span adjustment screw counterclockwise.
 - b. To decrease the span further than the adjustment screw allows, move both ends of link A (key 116) to the left.
 - c. Make fine adjustments with the remote set point span adjustment screw.
8. Repeat the adjustments until the upper and lower indications are aligned with the upper and lower limits on the process scale.
9. Adjust the remote set point pressure for 50 percent of the remote set point input range.
10. The set point indicator should indicate mid-scale ± 2 percent of the process scale span. If the error is within ± 2 percent, proceed to step 11. If the error is greater than ± 2 percent of the scale span, proceed to the remote set point linearity adjustment procedure.
11. Adjust the set point indicator to mid-scale ± 1 percent of the process scale span by loosening the zero adjustment locking screw and turning the zero adjustment screw. Tighten the locking screw.
12. Adjust the remote set point pressure to the upper and lower limits of the remote set point input range and make sure the set point indicator is still within ± 1 percent at the lower and upper limits of the process scale.
13. Perform the appropriate flapper alignment procedure and, if necessary, the process indicator zero and span calibration procedure in Section 3, 4, or 5.

Remote Set Point Linearity Adjustment

WARNING

Refer to the Maintenance WARNING on page 6-1.

Adjust the linearity by loosening and repositioning the linearity adjustment screw in the curved slot on the lever arm of pivot assembly B (key 115). Adjusting the linearity affects the zero and span adjustment.

1. Adjust the remote set point pressure to 50 percent of the remote set point input range. The set point indicator should indicate mid-scale ± 1 percent of the process scale span. If not, make fine adjustments by loosening the zero adjustment locking screw and turning the zero adjustment screw.
2. Adjust the remote set point pressure to 0 percent of the remote set point input range and note the indicator position relative to the process scale lower limit.
3. Adjust the remote set point pressure to 100 percent of the remote set point input range and note the indicator position relative to the process scale upper limit.
4. If the greatest misalignment is positive (the set point indicator is to the right of the process scale limits), loosen the linearity screw and move it clockwise in the slot. If the misalignment is negative, move the linearity screw counterclockwise in the slot.
5. If the misalignment is greater than 1 percent of the process scale span at the lower and upper limits, with one positive and the other negative, perform the remote set point zero and span adjustment procedure to correct a span error.
6. Repeat steps 1 through 4 until lower, middle, and upper indications are within ± 1 percent of the process scale markings.

Auto/Manual Station (suffix letter E) Maintenance

Replacing the Auto/Manual Station

WARNING

Refer to the Maintenance WARNING on page 6-1.

Refer to figures 7-1 and 7-7 for key number locations.

Note

This procedure also permits replacement of the switch manifold O-rings (key 312), the auto/manual tubing assembly (key 138), and the frame gaskets (keys 4 and 5).

Disassembly

1. Remove the controller assembly from the case by performing steps 1 through 3 of the case and cover replacement procedure.
2. Loosen the screw (key 316) that holds the auto/manual station (key 273) to the controller frame.
3. Loosen the two screws (keys 314 and 315) that hold the auto/manual station to the auto/manual tubing assembly (key 138).
4. Remove the auto/manual station from the controller frame.
5. Remove the switch manifold O-rings (key 312).
6. Carefully loosen the nut on the relay nozzle tubing assembly (key 18) where it connects to the auto/manual tubing assembly (key 138). Loosen three screws (keys 34 and 131) and remove the tubing assembly and frame gaskets (keys 4 and 5).
7. Inspect the gaskets (keys 4 and 5) and O-rings (key 312) for wear. Replace if necessary.

Assembly

1. Install the gaskets and tubing assembly to the frame. Start, but do not tighten, the three screws (keys 34 and 131) and the nut on the relay nozzle tubing assembly (key 18).
2. Install the switch manifold O-rings (key 312) and secure the auto/manual station to the controller frame with the screw (key 316) and to the tubing assembly (key 138) with the two screws (keys 314 and 315). Do not tighten any screws.

4195KA, KB, KC, and KS Controllers

CAUTION

In the next step, take care to tighten the two screws (keys 314 and 315) evenly. Uneven tightening could damage the tubing assembly.

3. Position the auto/manual station as far down on the frame and toward the scale as possible. Carefully tighten the two screws (keys 314 and 315) so that the auto/manual station contacts the three pads on the tubing assembly.
4. Carefully tighten the remaining screws and nuts.
5. Plug the controller output connection and apply supply pressure to the controller. Check for leaks.
6. Position the controller assembly in the case and start, but do not tighten the nine mounting screws. Slide the controller assembly down to assure an O-ring seal at the pressure connections along the bottom of the case. Hold the controller assembly in place while tightening the nine mounting screws.
7. Perform the appropriate calibration procedure in Section 3, 4, or 5.

Replacing the Switch Body Assembly, Lever O-Ring, Switch Body O-Ring, and Tubing Assembly

WARNING

Refer to the Maintenance WARNING on page 6-1.

Refer to figure 7-7 for key number location.

Disassembly

1. Remove the auto/manual station from the controller as described in steps 1 through 4 of the replacing the auto/manual station procedure.
2. Loosen the two screws (key 288) and remove the lever cover plate (key 305).

WARNING

The lever spring (key 302) is under preload. To avoid personal injury or losing parts, carefully disassemble the auto/manual station.

3. Using a 1/16-inch (1.5 mm) punch, push the groove pin (key 303) out toward the surface of the lever cover plate.
4. Remove the switch lever (key 304), lever spring (key 302), and lever spring seat (key 301).
5. Remove the tubing assembly (key 309).

WARNING

The switch body springs (key 295) are under preload. To avoid personal injury or losing parts, carefully separate the switch body assembly from the loader assembly.

6. Loosen the two screws (key 290) and separate the switch body assembly (key 291) from the loader assembly (key 282).
7. Remove the O-rings (keys 292, 293, and 294), switch body springs (key 295), and balls (key 296).
8. Loosen two screws (key 308), and remove the closing plate (key 307) and the closing plate gasket (key 306).
9. Pull the clip (key 300) from its engagement with the lever assembly shaft (key 297).
10. Pull the lever assembly from the switch body assembly (key 291) and rocker (key 299).
11. Remove the O-ring (key 298).
12. Inspect the O-rings and gaskets for damage or wear; replace if necessary.

Assembly

1. Insert the lever assembly (key 297) into the switch body assembly (key 291) and hold the rocker (key 299) with the flats on the lever assembly shaft.
2. Insert the clip (key 300) in the groove of the lever assembly shaft to hold the lever assembly (key 297) in the switch body assembly (key 291).
3. Position the closing plate gasket (key 306) and the closing plate (key 307). Secure with two screws (key 308).

Note

After assembly in step 3, be sure the side of the closing plate marked OUT is visible.

4. Place the balls (key 296), switch body springs (key 295), and O-rings (keys 292, 293, and 294) in the switch body assembly (key 291).

Note

In the following step, the ends of the springs must be in the counterbored spring seats before compression.

5. Compress the switch body springs with the loader assembly (key 282), and bolt the switch body assembly (key 291) to the loader assembly with the two screws (key 290).
6. Reconnect the tubing assembly (key 309).
7. Locate the lever spring (key 302) and the spring seat (key 301) on the switch lever (key 304) and position these parts in the opening of the loader assembly (key 282).
8. Push the switch lever down, using the lever spring seat (key 301) and the lever assembly (key 297) to preload the spring. Make sure the notch of the switch lever engages the pin of the lever assembly.
9. Drive in the groove pin (key 303) to hold the switch lever.
10. Replace the lever cover plate (key 305) and attach with two screws (key 288).
11. Perform the assembly portion of the replacing the auto/manual station procedure.

Replacing the Loader Range Spring, Diaphragm Assembly, Ball Seat, Tubing, and Ball



WARNING

Refer to the Maintenance WARNING on page 6-1.

Refer to figure 7-7 for key number locations.

Disassembly

1. Remove the auto/manual station from the controller as described in steps 1 through 4 of the replacing the auto/manual station procedure.
2. Remove the tubing assembly (key 309).



WARNING

To avoid personal injury caused by preload from the range spring (key 283), turn the loader knob (key 287) counterclockwise (opposite to the

arrow) to relieve pressure on the spring.

3. Loosen the four screws (key 289), and separate the upper loader assembly (key 282) and the lower loader assembly (key 274).
4. Remove the loader range spring (key 283), range spring cup (key 284), and diaphragm assembly (key 281).
5. Remove the tube (key 278), ball seats (key 280) and ball (key 279).

Assembly

1. Turn the loader knob (key 287) counterclockwise to back the spring adjustment screw (key 285) all the way out to eliminate loading the range spring.
2. Position the range spring cup (key 284), range spring (key 283), and the diaphragm assembly (key 281) on the upper loader assembly (key 282).
3. Position the ball (key 279), the tube (key 278), and the ball seats (key 280) between the ears of the loader assemblies (keys 282 and 274); position the diaphragm assembly (key 281) between the main halves of the loader assemblies.

Note

The tube (key 278) must be well seated in the cups of the ball seats (key 280).

4. Bolt the loader assembly halves together using the four screws (key 289).

Note

Be sure that the supply and exhaust seats of the loader are correctly aligned. Misalignment will impair loader performance.

5. Attach the tubing assembly (key 309).
6. Perform the assembly portion of the replacing the auto/manual station procedure.

4195KA, KB, KC, and KS Controllers

Replacing the Loader Valve Plug and Valve Plug Spring



WARNING

Refer to the Maintenance WARNING on page 6-1.

Refer to figure 7-7 for key number location.

1. Remove the controller assembly from the case by performing steps 1 through 3 of the case and cover replacement procedure.
2. Loosen the spring seat screw (key 275).
3. Remove the valve plug spring (key 276) and the valve plug (key 277).
4. Inspect the parts and replace as necessary.
5. Install the valve plug spring and valve plug.
6. Tighten the spring seat screw.
7. Temporarily apply supply pressure and process pressure and check for leaks.
8. Position the controller assembly in the case and start, but do not tighten the nine mounting screws. Slide the controller assembly down to assure an O-ring seal at the pressure connections along the bottom of the case. Hold the controller assembly in place while tightening the nine mounting screws.
9. Mount the controller as described in the Installation section.
10. Connect the external piping to the controller.

Section 7 Parts

Parts Ordering

Whenever corresponding with your Emerson Process Management sales office about this equipment, always mention the controller serial number. When ordering replacement parts, refer to the 11-character part number of each required part as found in the following parts list.



WARNING

Use only genuine Fisher replacement parts. Components that are not supplied by Emerson Process Management should not, under any circumstances, be used in any Fisher instrument. Use of components not supplied by Emerson will void your warranty, might adversely affect the performance of the instrument, and could give rise to personal injury and property damage.

Note

Neither Emerson, Emerson Process Management, nor any of their affiliated entities assumes responsibility for the selection, use, and maintenance of any product. Responsibility for the selection, use, and maintenance of any product remains with the purchaser and end-user.

Parts Kits

Description	Part Number
4190 Series Auto/Manual Repair Kit Contains keys 277, 278, 279, 281, 292, 293, 294, 298, 306, 312	R4190X0AM12
4190 Series Auto/Manual Retrofit Kit, SST tubing, Contains keys 138, 273, 312, 313, 314, 315, 316	R4190X00S12
4190 Series Case Handle Kit Contains lever and mounting hardware	R4190X00H12
4190 Series Controller Repair Kit Contains keys 4, 5, 7, 8, 24, 52	R4190X00C12
4190 Series Pointer and Bracket Repair Kit Contains pointer and bracket ass'y, three machine screws, three washers	R4190X00P12

Description	Part Number
4190 Series Relay Replacement Kit Contains Relay Assembly (includes keys 13 and 15) and key 10 0.2 to 1.0 bar (3 to 15 psig)	RRELAYX83C2
0.4 to 2.0 bar (6 to 30 psig)	RRELAYX83D2
Type 4195KBF Anti-Reset Windup Retrofit Kit, SST tubing, Contains keys 44 and 55	R4190X00S22

Parts List

Abbreviations Used In Parts List

adj:	adjustment
alt desgntrn:	alternative designation
ass'y:	assembly
conn(s):	connection(s)
diff:	differential (as in process differential pressure)
fdback:	feedback
fill hd:	fillister head (as in fillister head cap screw)
ext:	external
hd:	head (as in machine screw head)
int:	internal
OD:	outside diameter
p/o	part of (as in part of another assembly)
pl:	plated (as in plated steel)
pt:	point (as in set point)
qty:	quantity
SST:	stainless steel
w/:	with
w/o:	without

Key	Description	Part Number
-----	-------------	-------------

Controller Common Parts (figure 7-1)

Note

Figure 7-1 shows key numbers for the common construction of all controller types. Figure 7-1 continues over several pages. Be sure to check all pages of figure 7-1 to find the common key numbers.

1	Case and cover ass'y For use w/o remote set pt For use w/remote set pt	46A5903X012 46A5902X012
2	Nameplate, A91100 (aluminum)	---
3	Frame, A03600 (aluminum)	56A7001X012
4*	Frame gasket, chloroprene For use between frame and frame manifold (key 135)	18A0749X012
5*	Gasket, chloroprene 4195KA, KB, and KS (1 req'd) 4195KC (2 req'd)	18A0742X012
6	Machine screw, fill hd, 18-8 SST (9 req'd) 2 req'd to mount the prop band ind cover to the frame 4 req'd to mount bellows bracket (key 31) to bellows beam (key 49) 2 req'd to attach process scale brackets (keys 376, 377) to frame	1P4373X0012

4195KA, KB, KC, and KS Controllers

Key	Description	Part Number	Key	Description	Part Number
7*	O-Ring, nitrile Used between frame and case at conns: process pressure, either 1/4-18 NPT internal or 1/2-14 NPT external; output and supply; remote set point; and external feedback 3 req'd w/o remote set pt and w/o ext fdbck 4 req'd w/remote set pt or ext fdbck 5 req'd w/remote set pt and ext fdbck	1C376206992	40	Proportional tubing ass'y, SST For 4195KA or KB Series For 4195KC Series	28A0766X022 27A3217X022
8*	O-Ring, nitrile Used between frame and case on mounting bosses extending from the frame through the back of the case (3 req'd)	16A6903X012	41	Plug, S30300 (303 SST) For all 4195KA, KB, and KS Series (1 req'd) For 4195KC, KCM, KCE, and KCME (2 req'd) For 4195KCF, KCFM, KCFE, and KCFME (1 req'd)	1P2796X0012
9	Flexure pivot ass'y, sapphire/SST	29A4340X012	42	Reset valve tubing ass'y, SST For 4195KB Series w/o ext feedback, SST	16A6949X022
10	Machine screw, fill hd, 18-8 SST Used to attach the flexure pivot ass'y (key 9) to the frame (4 req'd)	18B0008X012	43	Reset tubing ass'y, SST For all 4195KB Series For all 4195KC Series	26A6950X022 28A0764X022
11*	Flapper ass'y	29A9518X012	44	Relief valve tubing ass'y, SST For Types 4195KBF, KBF, KBFM, and KBFME only	16A6951X022
12	Machine screw, hex socket, 18-8 SST For flapper ass'y (key 11) (2 req'd)	10B0700X012		For Types 4195KCF, KCFE, KCFM, and KCFME only	18A0763X022
17	Adjustable set pt pivot ass'y, SST	19A1121X012	45	Positive Feedback Tubing Assembly, SST For 4195KS Series only	18A0769X022
18	Relay nozzle tubing ass'y, SST	18A0765X012			
19	Machine screw, fill hd, 18-8 SST 1 req'd to attach adjustable set pt pivot ass'y (key 17) to frame For 4195KC Series 3 req'd to attach relay nozzle tubing ass'y (key 18) to frame	1C8990X0012			
20	Plain washer, 18-8 SST Used w/key 19 (2 req'd)	1K261028992			
21	Nozzle ass'y, SST	26A6904X012			
22	Washer, plastic (2 req'd)	16A9767X012			
23	Set pt beam ass'y, aluminum/SST	16A6939X012			
24*	O-ring, nitrile 1 req'd for nozzle tubing ass'y (key 18) 1 req'd for nozzle ass'y (key 21)	1E222606992			
25	Proportional band knob, polycarbonate	36A6911X012			
26	Retaining clip, S30200 (302 SST)	16A6913X012			
27	E-ring, SST	1V5929X0012			
28	Set pt beam bias spring, pl steel	16A6909X012			
29	Set pt beam shoe, G10100 (pl steel)	16A6910X012			
30	Machine screw, 18-8 SST Used w/key 29 (2 req'd)	19A1155X022			
31	Bellows bracket, A95052 (aluminum)	26A6932X012			
32	Bellows adj bracket, G10100 (pl steel)	16A6933X012			
33	Bellows adj spring, pl steel	16A6934X012			
34	Machine screw, fill hd, 18-8 SST Used to attach frame manifold (key 135) to frame and for reset gain adjustment (2 req'd)	18B0009X012			
35	Machine screw, hex hd, 18-8 SST Used to attach bellows bracket (key 31) to each bellows ass'y (key 48) (2 req'd)	16A6935X022			
36	Proportional band indicator cover, ABS w/polyester label	36A6936X012			
37	Self-tapping screw, 18-8 SST 4 req'd to attach process scale (key 61) to process scale bracket (key 376)	16A6938X022			
38	Self-tapping screw, 18-8 SST Used to attach frame inside case (9 req'd)	16A6959X022			
39	Supply gauge tubing ass'y, SST	16A6952X022			

Note

One type of pressure gauge is used for both output pressure and supply pressure indication.

46* Pressure gauge (2 req'd) See Key 46 table

Key 46 Pressure Gauge⁽¹⁾*

RANGE	GAUGE MATERIAL	
	Brass	SST
Dual Scale Gauge		
0 to 30 psig/ 0 to 2 kg/cm ²	11B8577X042	11B8583X032
0 to 60 psig/ 0 to 4 kg/cm ²	11B8577X052	---
Triple Scale Gauge		
0 to 30 psig/ 0 to 200 kPa/ 0 to 2 bar	11B8577X012	11B8583X012
0 to 60 psig/ 0 to 400 kPa/ 0 to 4 bar	11B8577X022	11B8583X022
1. One type of pressure gauge is used for both output pressure and supply pressure indication.		

Instruction Manual

Form 5207
April 2007

4195KA, KB, KC, and KS Controllers

Key	Description	Part Number	Key	Description	Part Number
48*	Bellows ass'y (2 req'd) Brass SST	16A6953X012 16A6953X022	56	Process and set pt indicator ass'y w/sensing element	
49	Bellows beam, A96061 (aluminum) 0.2 to 1.0 bar (3 to 15 psig) 0.4 to 2.0 bar (6 to 30 psig)	16A6957X012 16A6958X012		The part numbers in the Key 56 tables are for the complete process and set pt indicator ass'y with a process sensing element. Individual indicator ass'y parts are listed in two subsections of this parts list: the Process and Set Point Indicator Assembly (key 56) subsection and the Indicator Assembly (key 101) subsection. Key numbers for individual indicator parts also appear in figures 7-2 and 7-3.	
51	Relief valve cover plate, A03600 (aluminum)	2V597308012			
52*	O-ring, nitrile Used w/key 51 (2 req'd)	1C853806992			
53	Machine screw, fill hd, 18-8 SST Used w/key 51 (2 req'd) 4195KA, KB, and KS Series 4195KC Series (7 req'd)	1U8842X0012		Process and set pt indicator ass'y w/Bourdon tube sensing element	See Key 56 tables
54	Reset restriction valve (4195KB Series only)	19A4361X032		Process and set pt indicator ass'y w/capsular element ass'y	See Key 56 tables
55	Differential relief valve For all 4195KB and KC Series w/suffix letter F, anti-reset windup	21A6447X0A2			

Key 56 Process and Set Point Indicator Assembly with Bourdon Tube

BAR RANGE	PSIG RANGE	ASSEMBLY PART NUMBER	
		W/O Remote Set Point	W/Remote Set Point
With S31600 (316 SST) Bourdon Tube			
0 to 1.6 or 0 to 2 0 to 4 or 0 to 2.5 0 to 6 0 to 10	0 to 30 0 to 60 0 to 100 0 to 200	32B1532X012 32B1532X022 32B1532X032 32B1532X042	32B1532X142 32B1532X152 32B1532X162 32B1532X172
0 to 16 0 to 40 or 0 to 25 0 to 60 0 to 100	0 to 300 0 to 600 0 to 1000 0 to 1500	32B1532X052 32B1532X062 32B1532X072 32B1532X082	32B1532X182 32B1532X192 32B1532X202 32B1532X212
0 to 160 0 to 250 or 0 to 300	0 to 3000 0 to 5000	32B1532X092 32B1532X102	32B1532X222 32B1532X232

Key 56 Process and Set Point Indicator Assembly with Capsular Element Assembly

RANGE	ASSEMBLY PART NUMBER	
	W/O Remote Set Point	W/Remote Set Point
	N09902	N09902
Positive and Compound Element		
U.S. Units	0 to 60 inch wc 0 to 5 psig 0 to 10 Psig 0 to 12 Psig 0 to 15 Psig 0 to 20 Psig 0 to 24 Psig 0 to 30 Psig	36A6986X082 36A6986X092 36A6986X102 36A6986X112 36A6986X302 36A6986X122 36A6986X132 36A6986X142
Vacuum Element		
U.S. Units	-5 to 0 Inch Hg -10 to 0 Inch Hg -20 to 0 Inch Hg -30 to 0 Inch Hg	36A6987X052 36A6987X062 36A6987X072 36A6987X082

*Recommended spare parts

Instruction Manual

Form 5207
April 2007

4195KA, KB, KC, and KS Controllers

Key 61 Process Scale, Positive Pressure

Scale Range	Part Number			
Bar Scales	0 to 150 mbar 0 to 400 mbar 0 to 0.6 0 to 1	1R0003X1562 1R0003X0422 1R0003X0402 1R0003X0432		
	0.2 to 1 0 to 1.4 0 to 1.6 0 to 2 0.4 to 2	1R0003X1602 1R0003X1612 1R0003X0442 1R0003X1652 1R0003X1622		
	0 to 2.5 0 to 4 0 to 6 0 to 10 0 to 16	1R0003X0452 1R0003X0462 1R0003X0472 1R0003X0482 1R0003X0492		
	0 to 25 0 to 40 0 to 60 0 to 100 0 to 160	1R0003X0572 1R0003X0502 1R0003X0512 1R0003X0522 1R0003X0532		
	0 to 250	1R0003X0542		
	Psig Scales	0 to 60 inch wc 0 to 5 0 to 10 3 to 15 0 to 15	1R0003X0202 1R0003X0212 1R0003X0222 1R0003X0172 1R0003X0232	
		0 to 20 6 to 30 0 to 30 0 to 60 0 to 100	1R0003X0242 1R0003X0182 1R0003X0032 1R0003X0042 1R0003X0052	
		0 to 200 0 to 300 0 to 600 0 to 1000 0 to 1500	1R0003X0062 1R0003X0072 1R0003X0082 1R0003X0092 1R0003X0102	
		0 to 3000 0 to 5000	1R0003X0112 1R0003X0122	
		kPa Scales	0 to 200 0 to 400 0 to 700 0 to 1400 0 to 2000	1R0003X0922 1R0003X0932 1R0003X0942 1R0003X0702 1R0003X0952
			0 to 4000 0 to 7000 0 to 10,000 0 to 20,000 0 to 35,000	1R0003X0962 1R0003X0972 1R0003X0712 1R0003X0982 1R0003X0992

Key 61 Process Scale, All Controllers

Scale Range	Part Number
0 to 100%	1R0003X1042
0 to 10 Square Root	1R0003X1172
0 to 100 Square Root	1R0003X1292

Key 61 Process Scale, Vacuum and Compound Pressure

SCALE RANGE		PART NUMBER	
Vacuum Pressure			
Bar Scales	150 to 0 mbar 400 to 0 mbar 0.6 to 0 1 to 0	1R0003X1632 1R0003X0592 1R0003X0602 1R0003X0612	
	In Scales	5 to 0 10 to 0 20 to 0 30 to 0	1R0003X0322 1R0003X0332 1R0003X0342 1R0003X0192
		Compound Pressure	
		Bar Scales	-50 to +100 mbar -150 to +250 mbar -0.2 to +0.4 -0.4 to +0.6 -0.6 to +0.8 -1 to +0.6 -1 to +1
Psig Scales			30 inches wc vac. to 30 inches wc 5 inches Hg vac. to 2.5 psig 10 inches Hg vac. to 5 psig 15 inches Hg vac. to 7.5 psig 20 inches Hg vac. to 10 psig 30 inches Hg vac. to 15 psig

Key	Description	Part Number
136	Rate/reset manifold, A03600 (aluminum) For all types except 4195KC Series	28A0747X012
137	Rate tubing ass'y (for 4195KC Series only) SST/aluminum	28A0762X042
138	Auto/manual tubing ass'y Use w/suffix letter E, auto/manual station only SST/aluminum	38A2859X022
140	Machine screw, fill hd, 18-8 SST Used to attach remote set pt ass'y (suffix letter M) to indicator ass'y (key 56)	16A7007X022
162	Machine screw, hex hd, 18-8 SST Used to attach the reset valve (4195KB Series) or rate/reset valve (4195KC Series) to the frame For 4195KB and KC Series only	1B8480X0012
262	Rate/reset valve ass'y (for 4195KC Series only) Brass bellows 0.2 to 1.0 bar (3 to 15 psig) 0.4 to 2.0 bar (6 to 30 psig) SST bellows 0.2 to 1.0 bar (3 to 15 psig) 0.4 to 2.0 bar (6 to 30 psig)	39A6013X052 39A6013X072 39A6013X062 39A6013X082
273	Auto/manual station (suffix letter E)	48A2905X012

The part number listed for key 273 is for the complete auto/manual station (suffix letter E). Individual ass'y parts are listed in the Auto/Manual Station subsection of the parts list. Key numbers for individual ass'y parts also appear in figure 7-7.

310	Lithium grease (not furnished with controller)	
311	Anti-seize sealant (not furnished with controller)	
312*	O-ring, nitrile For all types w/suffix letter E, auto/manual station (3 req'd)	1P8453X0022

4195KA, KB, KC, and KS Controllers

Instruction Manual

Form 5207

April 2007

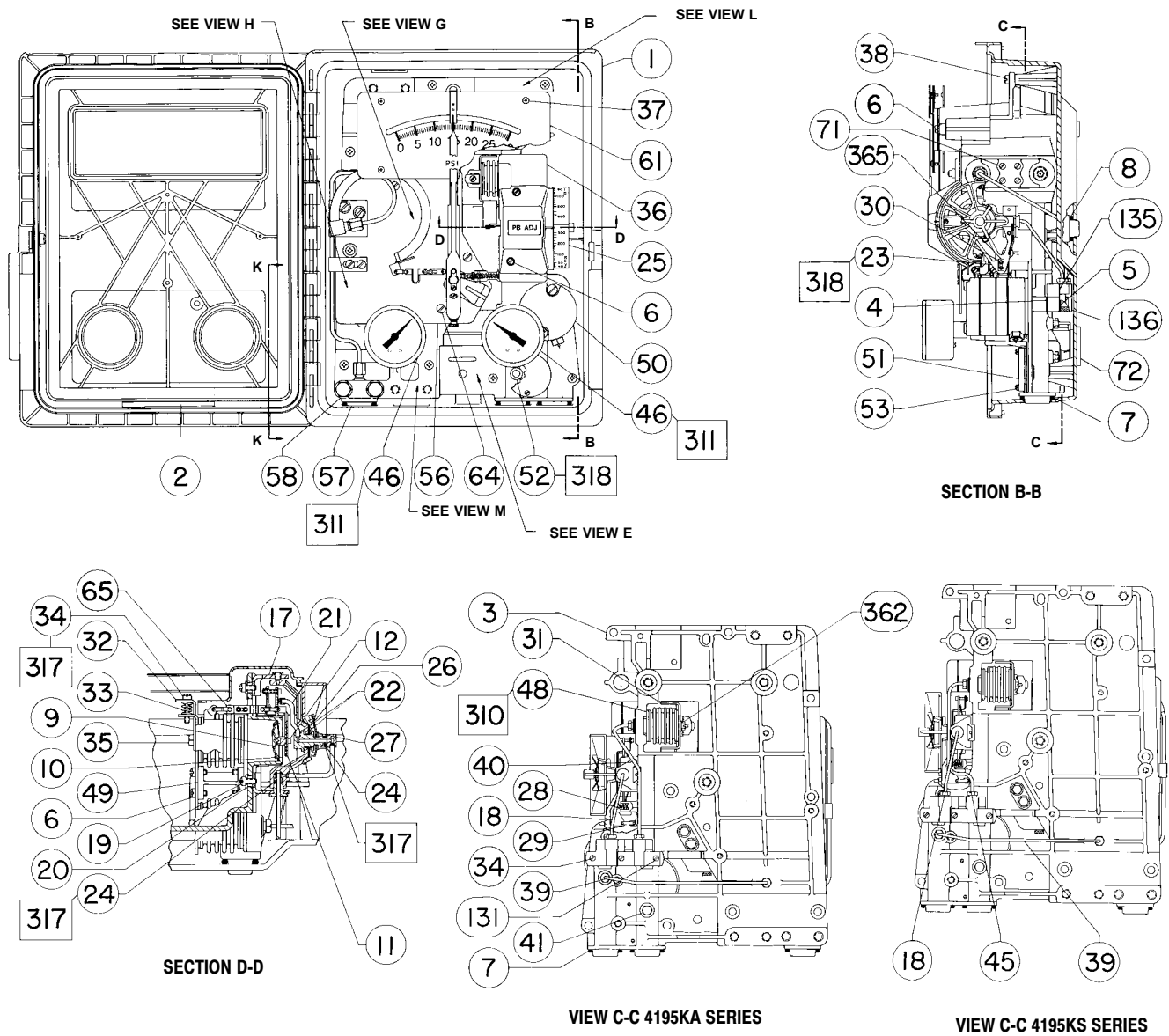

Figure 7-1. Controller Assembly Drawings

Key	Description	Part Number	Key	Description	Part Number
313	Auto/Manual Scale, plastic For all types w/suffix letter E, auto/manual station	38A2901X012	316	Machine screw, SST For all types w/suffix letter E, auto/manual station	1U8841X0012
314	Machine screw, fill hd, 18-8 SST For all types w/suffix letter E, auto/manual station	1C101535042	317	Silicone based lubricant, (not furnished with controller)	
315	Machine screw, fill hd, 18-8 SST For all types w/suffix letter E, auto/manual station	1B9925X0012	318	Lubricant, silicone, not furnished with controller)	
			339	External feedback ass'y, SST tubing For controllers w/Bourdon tube or vacuum capsule	28A7285X022
				For controllers w/positive or w/compound capsules	29A5715X022
			362	Spring retaining washer, SST	1B196138992
			365	Washer, 18-8 SST	11B6501X012

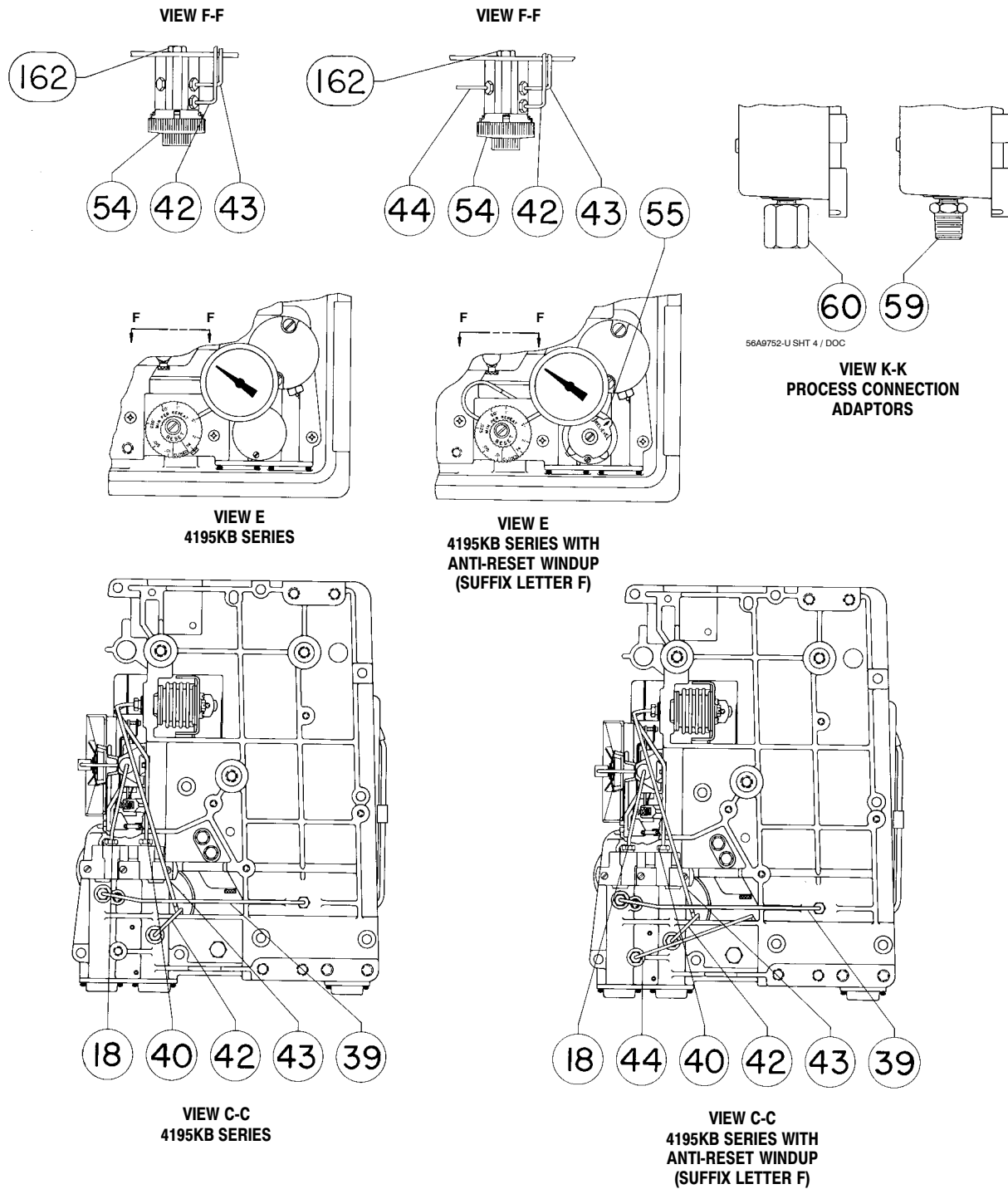
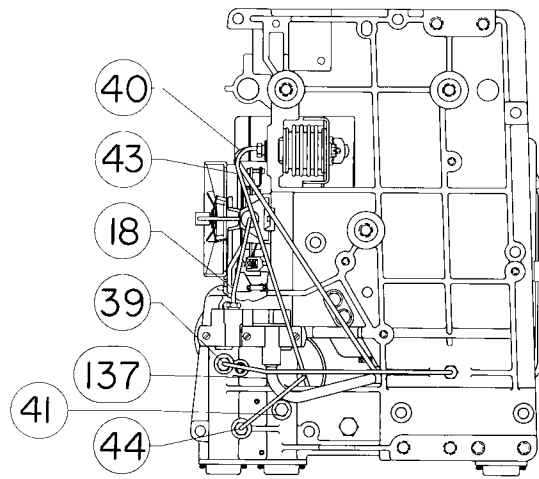
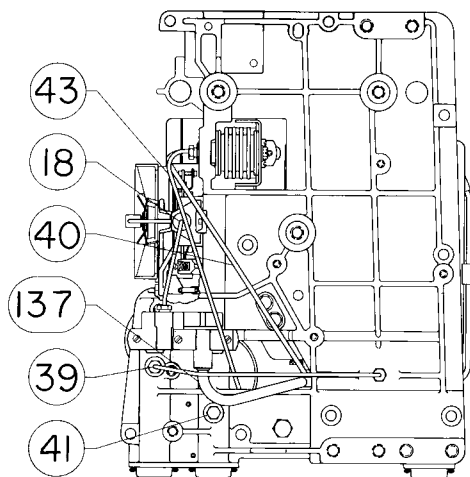
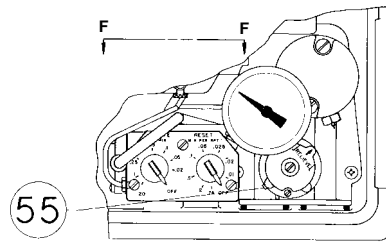
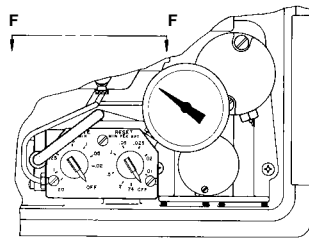
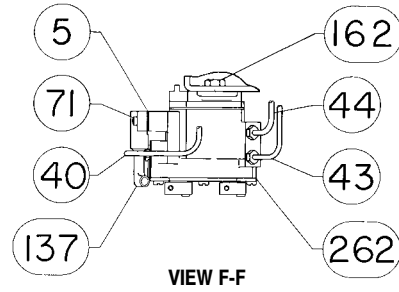
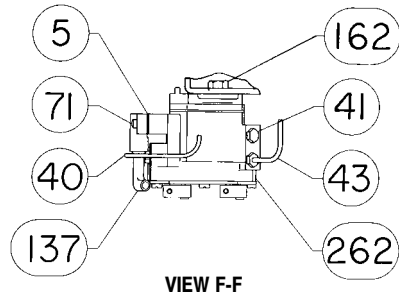

Figure 7-1. Controller Assembly Drawings (cont'd)

4195KA, KB, KC, and KS Controllers



56A9752-U SHT 3 / DOC

Figure 7-1. Controller Assembly Drawings (cont'd)

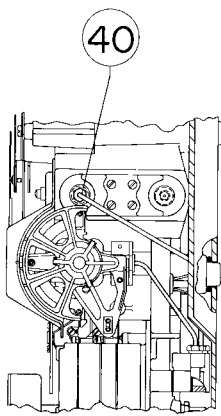

**SECTION B-B
4195KA SERIES**

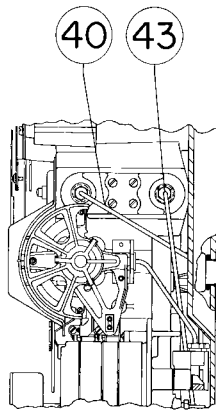

**SECTION B-B
4195KB SERIES**

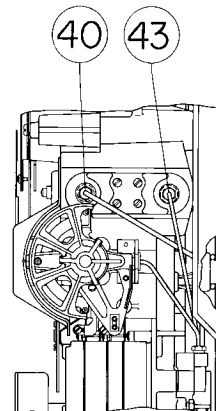

**SECTION B-B
4195KC SERIES**

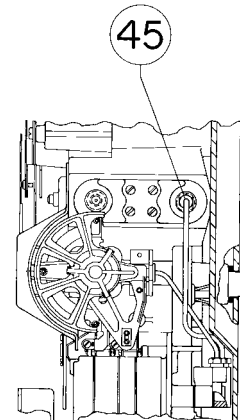

**VIEW B-B
4195KS SERIES**

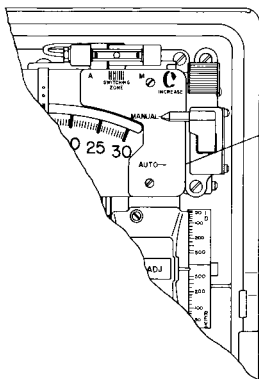

VIEW L

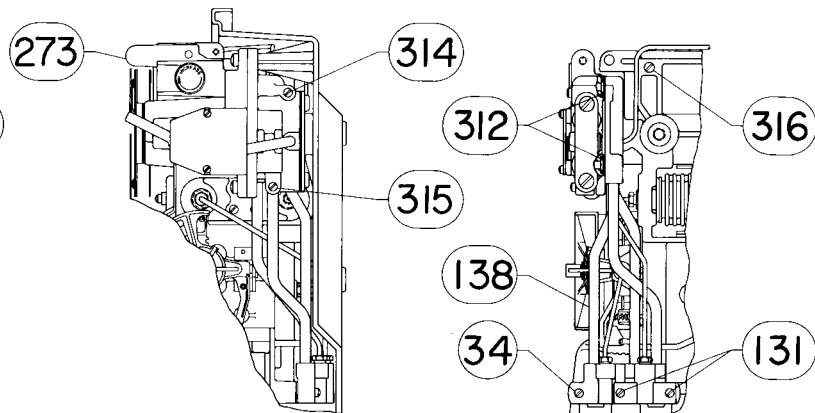

**CONTROLLERS WITH AUTO/MANUAL STATION
(SUFFIX LETTER E)**

Figure 7-1. Controller Assembly Drawings (cont'd)

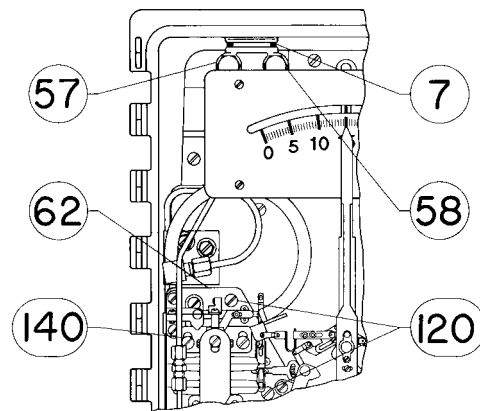

56A9752-U SHT 4 / DOC

VIEW H
CONTROLLERS WITH REMOTE SET POINT
(SUFFIX LETTER M)

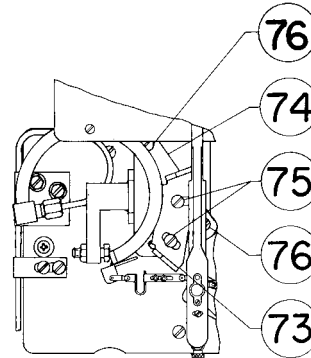

VIEW G
BOURDON TUBE
TRAVEL STOPS

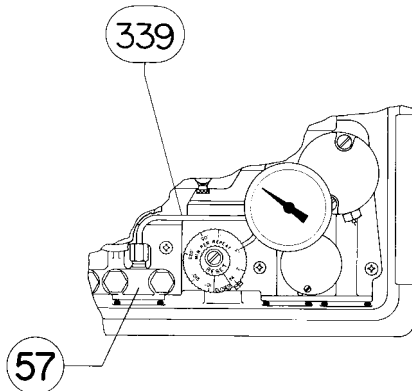

56A9752-U SHT 3 / DOC

VIEW M
EXTERNAL FEEDBACK FOR
4195K SERIES BOURDON TUBE
AND VACUUM PRESSURE CONTROLLERS

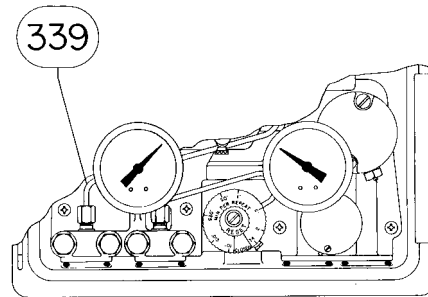

56A9752-U SHT 5 / DOC

VIEW M
EXTERNAL FEEDBACK FOR
4195K SERIES POSITIVE AND
COMPOUND PRESSURE CONTROLLERS

Figure 7-1. Controller Assembly Drawings (cont'd)

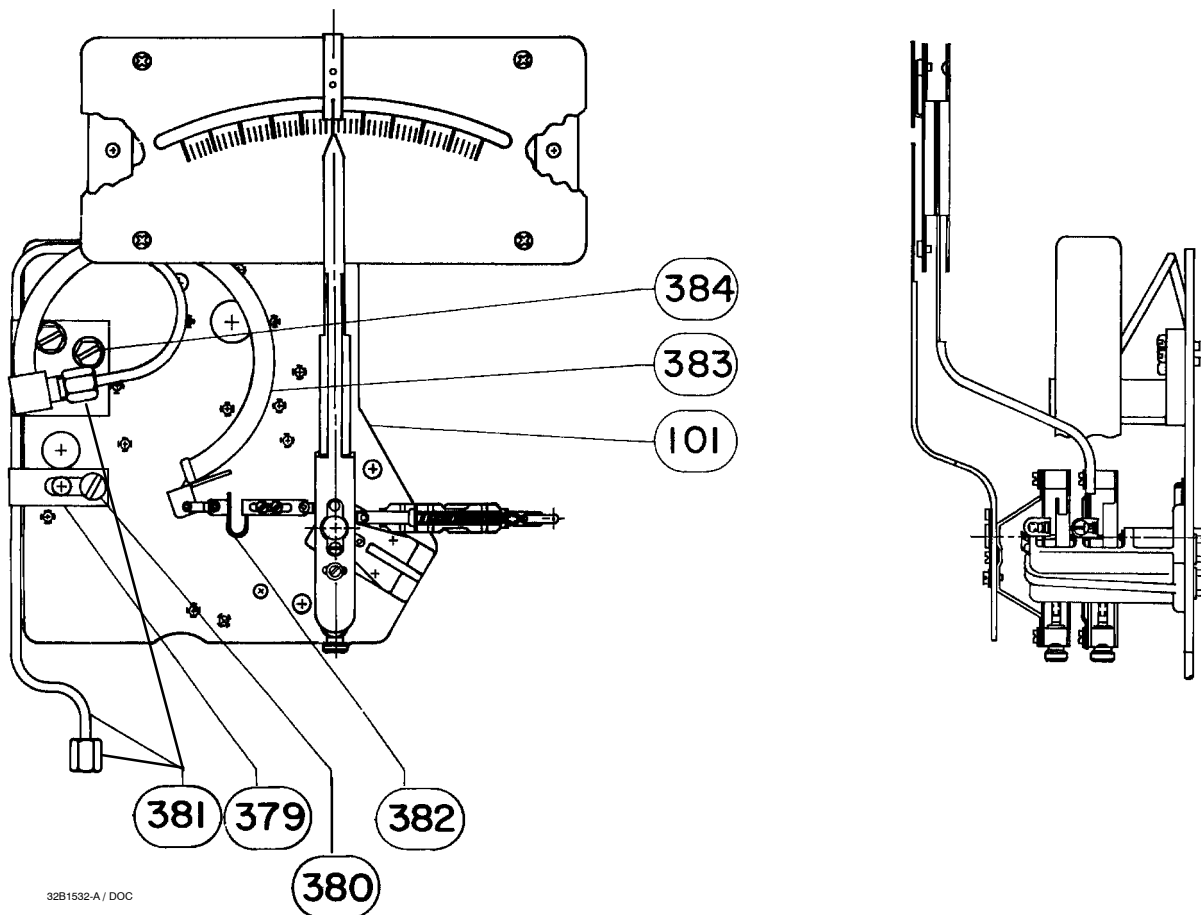

Figure 7-2. Process and Set Point Indicator Assembly for Bourdon Tube Controllers

Process and Set Point Indicator Assembly (key 56) (figures 7-2 and 7-3)

Key	Description	Part Number
-----	-------------	-------------

With capsular element ass'y

101	Indicator ass'y	
<p>The part numbers listed here for key 101 are for the indicator ass'y only. Individual part numbers are listed in the Indicator Assembly and the Capsular Element Assembly subsections of this parts list. Key numbers for individual ass'y parts also appear in figures 7-4 and 7-5.</p>		
	For use w/o remote set pt	39A1126X012
	For use w/remote set pt	39A1126X022

113	Capsular element ass'y	See Key 113 table
-----	------------------------	-------------------

The part numbers listed in the key 113 table are for the complete capsular element ass'y. Individual ass'y parts are listed in the Capsular Element Assembly subsection of this parts list. Key numbers for individual ass'y parts also appear in figure 7-4.

Key	Description	Part Number
-----	-------------	-------------

127	Machine screw, fill hd, 18-8 SST 4 req'd to attach the capsular element ass'y to the indicator ass'y (key 101)	1J8415X0012
-----	---	-------------

With Bourdon tube

101	Indicator ass'y	
<p>The part numbers listed here for key 101 are for the indicator ass'y only. Individual part numbers are listed in the Indicator Assembly subsection of this parts list. Key numbers for individual ass'y parts also appear in figure 7-4.</p>		
	For use w/o remote set pt	39A1126X012
	For use w/remote set pt	39A1126X022
379	Process Tube Retainer, S30400 (304 SST)	18A8870X012
380	Machine screw, pan hd, 18-8 SST	1H2674X0012
381	Process tubing ass'y, SST	12B4951X012
382	Link ass'y, steel/SST	22B0469X012
383*	Bourdon tube	See Key 383 table
384	Screw, self-tapping, pl steel (2 req'd)	16A9772X022

*Recommended spare parts

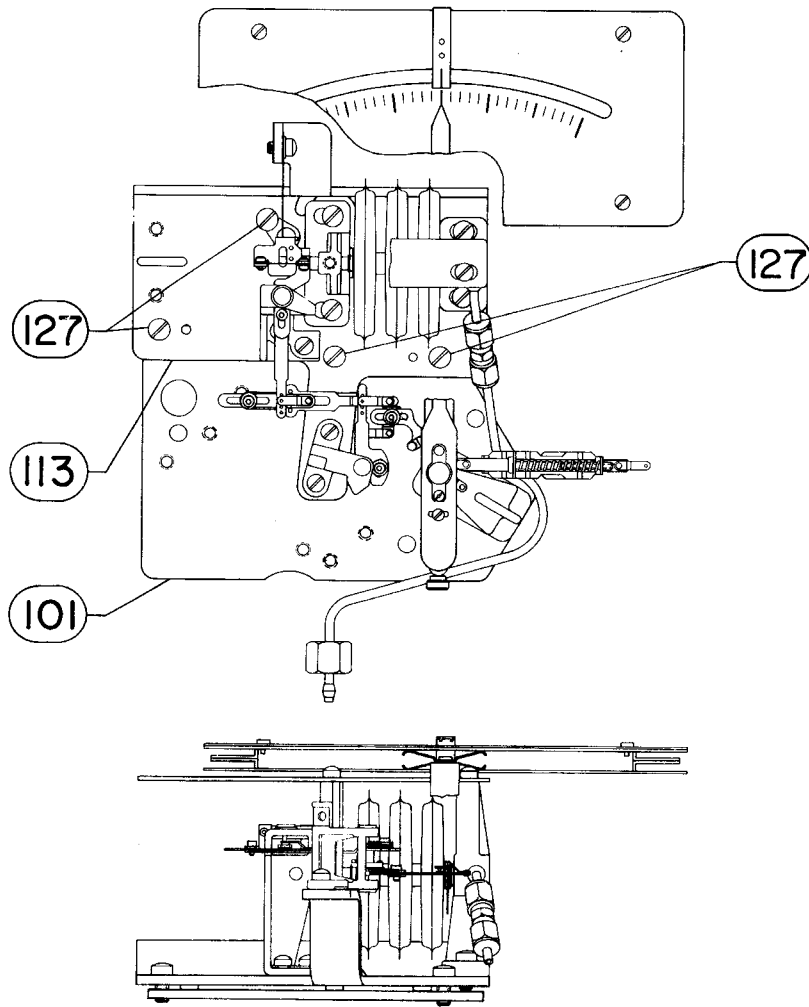

38A6986-C / DOC

Figure 7-3. Process and Set Point Indicator Assembly for Capsular Element Controllers
(Positive and Compound Pressure Shown)

Instruction Manual

Form 5207
April 2007

4195KA, KB, KC, and KS Controllers

Key 113 Capsular Element Assembly⁽¹⁾

PRESSURE RANGE		MATERIAL
		N09902
Positive	0 to 60 inch wc 0 to 5 psig 0 to 10 psig 3 to 15 psig	58A0708X082 58A0708X092 58A0708X102 58A0708X112
	0 to 15 psig 0 to 20 psig 6 to 30 psig 0 to 30 psig	58A0508X152 58A0708X122 58A0708X132 58A0708X142
Vacuum	-5 to 0 inch Hg -10 to 0 inch Hg -20 to 0 inch Hg -30 to 0 inch Hg	58A0710X052 58A0710X062 58A0710X072 58A0710X082
Compound	-30 to 30 inch wc -5 inch Hg to 2.5 psig -10 inch Hg to 5 psig	58A0708X172 58A0708X182 58A0708X192
	-15 inch Hg to 7.5 psig -20 inch Hg to 10 psig -30 inch Hg to 15 psig	58A0708X202 58A0708X272 58A0708X222
<small>1. For information on scale compatibility, consult your Emerson Process Management sales office. Capsular Element Assembly may be ordered as part of the Process/Setpoint Indicator Assembly (key 56) or ordered separately. See Capsular Element Assembly section for available replacement parts.</small>		

Key 383* Bourdon Tubes

BAR RANGE	PSIG RANGE	PART NUMBER
S31600 (316 SST) Bourdon Tube		
0 to 1.6 or 0 to 2 0 to 4 or 0 to 2.5 0 to 6 0 to 10	0 to 30 0 to 60 0 to 100 0 to 200	32B4589X012 32B4589X022 32B4589X032 32B4589X042
0 to 16 0 to 40 or 0 to 25 0 to 60 0 to 100	0 to 300 0 to 600 0 to 1000 0 to 1500	32B4589X052 32B4589X062 32B4589X072 32B4589X082
0 to 160 0 to 250 or 0 to 300	0 to 3000 0 to 5000	32B4589X092 32B4589X102

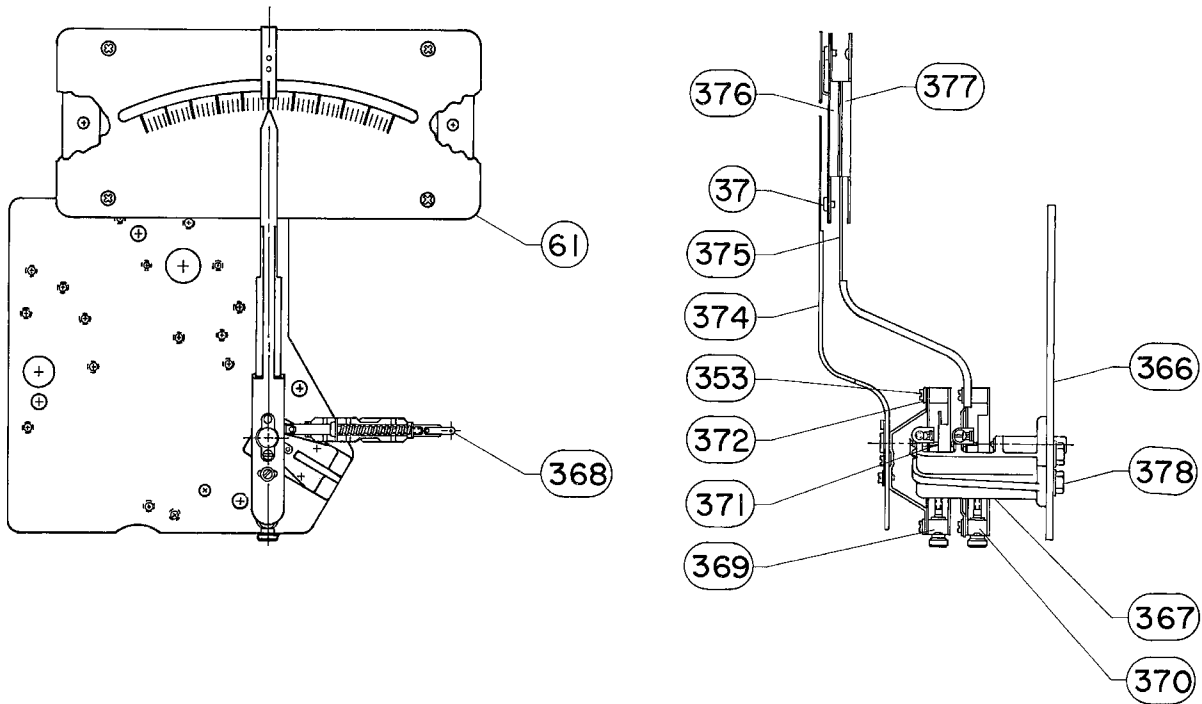

39A1126-H / DOC

Figure 7-4. Indicator Assembly

Indicator Assembly (key 101) (figure 7-4)

Key	Description	Part Number
-----	-------------	-------------

Note

Key numbers 37, 61, 376, 377, and 378 are not included as part of the indicator assembly (key 101). If replacing the indicator assembly and these parts are required, order them separately.

37	Self-tapping screw, 18-8 SST 4 req'd to attach process scale (key 61) to process scale bracket (key 376)	16A6938X022
61	Process scale, aluminum	See Key 61 table
353	Machine screw, pan hd, 18-8 SST (4 req'd)	16A7044X022
366	Controller Mounting Plate, 18-8 SST	38A1735X012
367	Support bracket ass'y, zinc/brass	16A7013X012
368	Link ass'y, 18-8 SST (2 req'd)	16A7039X012
369	Process pointer adj ass'y, aluminum/SST/brass	28A1736X012
370	Set pt pointer ass'y aluminum/SST/brass	26A9750X012
371	Pivot pin, S30200 (302 SST) (2 req'd)	16A7027X012
372	Washer, plain, 18-8 SST (4 req'd)	1V7657X0012
374	Pointer and bracket ass'y aluminum/steel	26A7059X012

Key	Description	Part Number
375	Set pt indicator ass'y, A93003 (aluminum) For controllers w/remote set pt For controllers w/o remote set pt	31B2241X012 26A7045X012
376	Dial Bracket, G10080 (steel)	36A7050X012
377	Dial bracket, G10080 (steel)	36A7051X012
378	Screw, self-tapping, 18-8 SST (2 req'd)	16A9772X022

Capsular Element Assembly (key 113) (figure 7-5)

12	Cap screw, hex socket, 18-8 SST (2 req'd)	1U621332982
13	Plain washer, 18-8 SST (2 req'd)	61000310X12
77	Mounting plate, G10100 (pl steel)	38A0667X012
78	Long pivot clevis ass'y, plastic/SST	26A9784X012
79	Drive flexure, S30200 (302 SST)	16A9794X012
80	Diaphragm capsule ass'y	See Key 80 table
81	Pedestal assembly, SST	18A0670X012
82	Diaphragm ass'y extension, A96061 (aluminum) See key 80 table to determine if required	18A0698X012
83	Travel stop, CF8 (SST casting)	16A9797X012
84	Drive bracket ass'y, SST	16A9798X012
86	Travel stop nut, S30300 (303 SST) See key 80 table for quantity	16A9799X012
87	Set screw, 18-8 SST 1 req'd for drive bracket ass'y (key 84), 1 req'd for each travel stop nut (key 86)	1J8406X0012 1J8406X0012
88	Connecting link ass'y, aluminum/bronze/brass	10B8448X012
89	Short pivot clevis ass'y, plastic/SST	16A9791X012

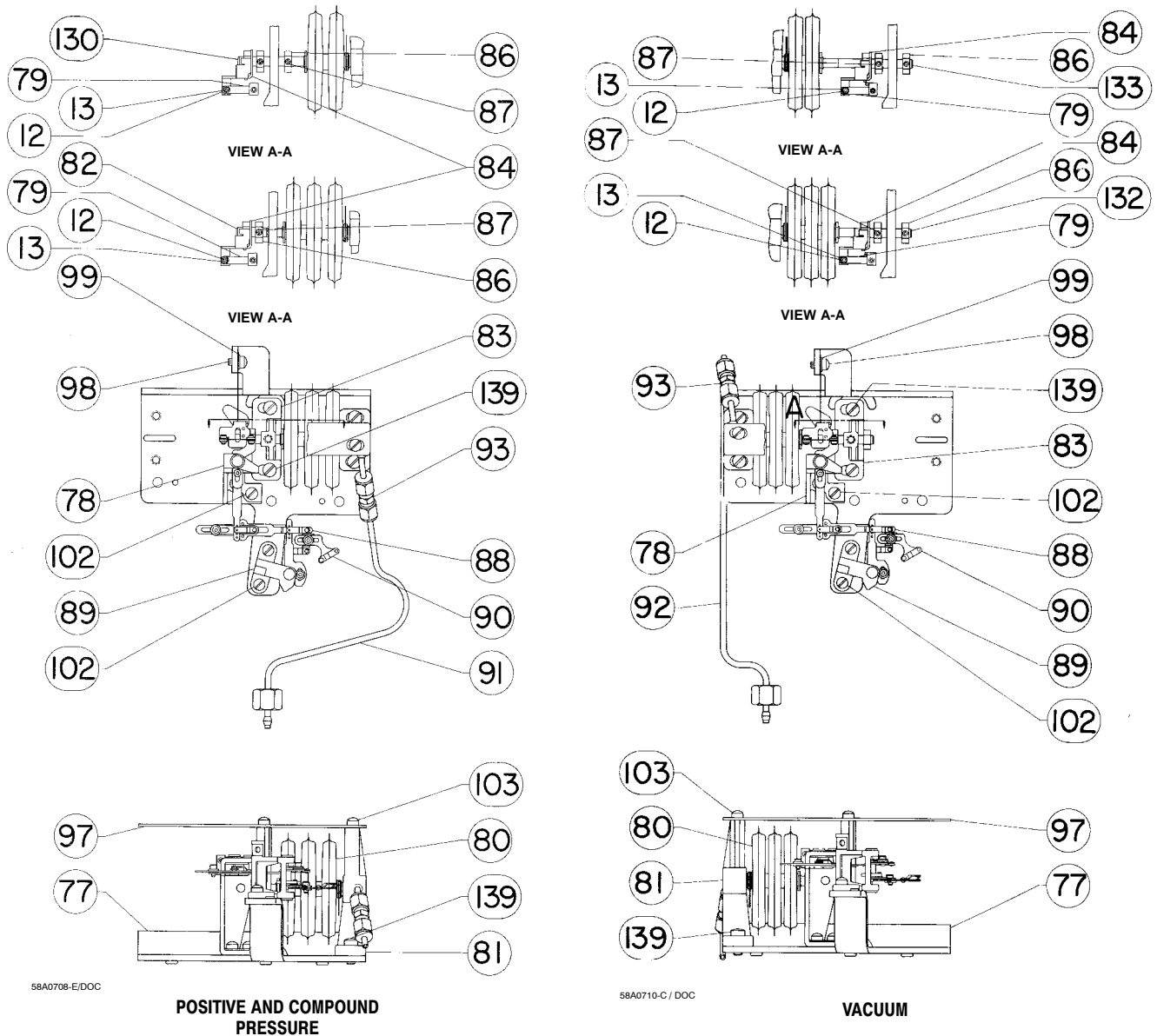

58A0708-E/DOC

58A0710-C / DOC

Figure 7-5. Capsular Element Assembly

Key	Description	Part Number	Key	Description	Part Number
90	Connecting link ass'y, aluminum/bronze/brass	10B8769X012	102	Machine screw, fill hd, 18-8 SST For mounting the short pivot clevis ass'y (key 89) and the long pivot clevis ass'y (key 78) to the mounting plate (key 77) (4 req'd)	18A0703X022
91	Process tubing ass'y, S30400 (304 SST) (positive and compound capsule only)	28A0682X012	103	Machine screw, pan hd, 18-8 SST For mounting tie bar (key 97) to pedestal ass'ies (key 81) and to travel stop (key 83) (2 req'd)	18A0703X022
92	Process tubing ass'y, S30400 (304 SST) (vacuum capsule only)	18A0683X012	130	Diaphragm ass'y extension, A96061 (aluminum) See key 80 table to determine if required	18A0699X012
93	Union, S31600 (316 SST)	1A5782X0022	132	Diaphragm ass'y extension, A96061 (aluminum) See key 80 table to determine if required	18A0700X012
97	Tie bar, G10100 (pl steel)	26A9803X012			
98	Machine screw, fill hd, 18-8 SST Used to attach the guide flexure (p/o drive bracket ass'y) to mounting plate	18A0703X022			
99	Plain washer, 18-8 SST	61000370X12			

4195KA, KB, KC, and KS Controllers

Key 80 Capsular Element Assembly, Travel Stop (key 86) and Diaphragm Assembly Extension

RANGE		CAPSULAR ELEMENT MATERIAL		
		N09902		
		Capsular Element (key 80) Part Number	Number of Travel Stops (key 86) Required	Diaphragm Assembly Extension Required
Positive and Compound Element				
Metric units	0 to 150 mbar	26A9773X012	1	key 82
	0 to 400 mbar	26A9775X012	2	key 130
	0 to 0.6 bar	26A9775X012	2	key 130
	0 to 1 bar and 0.2 to 1 bar	26A9776X032	2	key 130
	0 to 1.4 bar	26A9777X012	2	key 130
	0 to 1.6 bar and 0 to 2 bar	26A9779X012	1	key 82
	0.4 to 2 bar	26A9778X022	2	key 130
U. S. units	0 to 60 inch wc	26A9773X012	1	key 82
	0 to 5 psig	26A9774X012	1	key 82
	0 to 10 psig	26A9775X012	2	key 130
	0 to 15 psig and 3 to 15 psig	26A9776X032	2	key 130
	0 to 20 psig	26A9777X012	2	key 130
	6 to 30 psig	26A9778X022	2	key 130
	0 to 30 psig	26A9779X012	1	key 82
Vacuum Element				
Metric units	-150 to 0 mbar	26A9773X012	2	key 132
	-400 to 0 mbar and 0.6 to 0 bar	26A9775X012	2	key 133
	-1 to 0 bar	26A9776X032	2	key 133
U. S. units	-5 to 0 inch Hg	26A9773X012	2	key 132
	-10 to 0 inch Hg	26A9774X012	2	key 132
	-20 to 0 inch Hg	26A9775X012	2	key 133
	-30 to 0 inch Hg	26A9776X032	2	key 133

Key	Description	Part Number	Key	Description	Part Number
133	Diaphragm ass'y extension, A96061 (aluminum) See key 80 table to determine if required	18A0701X012	80	Diaphragm capsule ass'y 1 bar (12 psig) span N09902 (Nickel Alloy) SST	26A9776X032 28A2848X022
139	Machine screw, fill hd, 18-8 SST 2 req'd to mount each pedestal ass'y (key 81) (4 req'd)	1J8415 X0012		2 bar (24 psig) span N09902 (Nickel Alloy) SST	26A9778X022 28A2850X022
Relay (figure 6-2)					
Relay Assembly (includes keys 13 and 15)					
	0.2 to 1.0 bar (3 to 15 psig)	32B0257X0C2	83	Travel stop, CF8 (SST casting)	16A9797X012
	0.4 to 2.0 bar (6 to 30 psig)	32B0257X0D2	86	Travel stop nut, S30300 (303 SST)	16A9799X012
10	Relay mounting screw, 18-8 SST (2 req'd)	1U901238982	87	Set screw, hex socket, 18-8 SST	1J8406X0012
13*	O-ring, nitrile	17A6891X012	93	Union, S31600 (316 SST)	1A5782X0022
15*	O-ring, nitrile (2 req'd)	1D687506992	99	Plain washer, 18-8 SST	61000370X12
Note					
The above relay parts are included in the 4190 Series Relay Replacement Kit.					
Remote Set Point Assembly (suffix letter M) (key 62) (figure 7-6)					
12	Cap screw, hex socket, 18-8 SST (2 req'd)	1U621332982	102	Machine screw, fill hd, 18-8 SST (4 req'd)	18A0703X022
13	Plain washer, 18-8 SST (3 req'd)	61000310X12	103	Machine screw, pan hd, 18-8 SST (2 req'd)	18A0703X022
79	Drive flexure, SST	16A9794X012	104	Remote set pt tubing ass'y, S30400 (304 SST)	28A0697X012
			105	Pedestal ass'y, SST	18A0669X022
			106	Tie bar, G10100 (pl steel)	16A9789X022
			107	Spring, pl steel	18A0704X012
			108	Zero adj screw, S30300 (303 SST)	18A1737X022
			109	Pivot screw, S30300 (303 SST)	18A1738X022
			110	Zero adj bracket, S30400 (304 SST)	28A0661X012

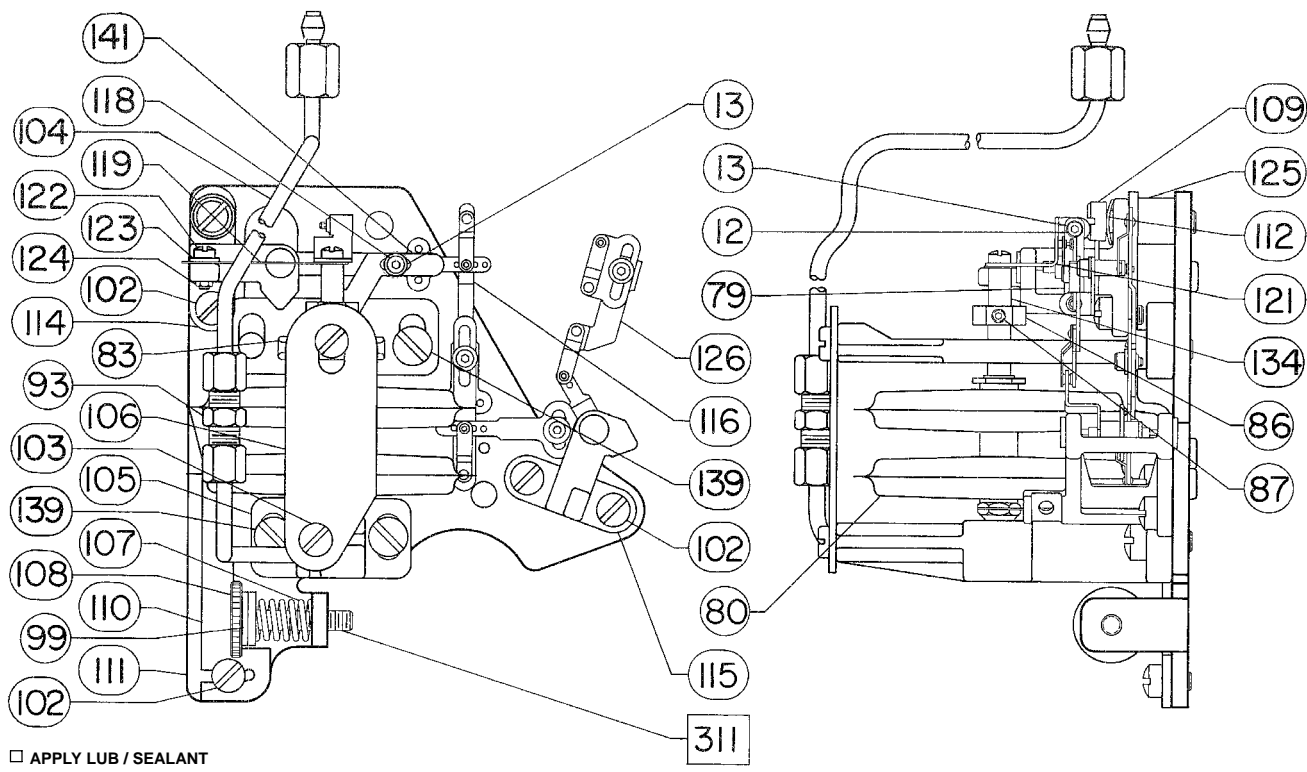

□ APPLY LUB / SEALANT
36A6988-C / DOC

Figure 7-6. Remote Set Point Assembly

Key	Description	Part Number	Auto/Manual Station (suffix letter E) (figure 7-7)		
111	Mounting plate, G10100 (pl steel)	38A0668X012	274	Lower loader ass'y, aluminum	18A2892X012
112	Spring washer, pl steel	17A2700X012	275	Spring seat screw, pl steel	18A2876X012
114	Pivot clevis ass'y A, plastic/SST	18A0658X012	276	Valve plug spring, K08500 (pl steel)	18A2877X012
115	Pivot clevis ass'y B, plastic/SST	16A9808X012	277	Valve plug, 18-8 SST	18A2878X012
116	Connecting link ass'y, aluminum/bronze/brass	18A0666X012	278	Tube, plastic	18A2880X012
118	Cap screw, hex socket, 18-8 SST	1U621332982	279	Ball, SST	18A2902X012
119	Guide flexure, S30200 (302 SST)	18A0660X012	280	Ball seat, nitrile (2 req'd)	18A2881X012
121	Drive bracket, S30400 (304 SST)	28A0662X012	281	Diaphragm ass'y, nitrile/aluminum	18A2884X012
122	Machine screw, fill hd, 18-8 SST (2 req'd)	1U3737X0012	282	Loader ass'y, aluminum/plastic	18A2893X012
123	Plain washer, 18-8 SST	1P752438982	283	Range spring, SST	18A2885X012
124	Nut, Hex, 18-8 SST	60000410X12	284	Range spring cup, pl steel	18A2869X012
125	Spacer, A92011 (aluminum)	18A0702X012	285	Spring adj screw, pl steel	18A2886X012
126	Connecting link ass'y, aluminum/bronze/brass	18A0676X012	286	Retaining ring, pl steel	18A2903X012
134	Diaphragm ass'y extension, A92011 (aluminum)	18A1739X012	287	Loader knob, plastic	18A2891X012
139	Machine screw, fill hd, 18-8 SST (3 req'd)	1J8415X0012	288	Machine screw, rd hd, 18-8 SST (2 req'd)	1C208235072
141	Adj arm, S30400 (304 SST)	28A0663X012	289	Machine screw, fill hd, 18-8 SST (4 req'd)	1C8969X0012
311	Anti-seize sealant (not furnished with controller)		290	Machine screw, fill hd, S30200 (302 SST) (2 req'd)	1K318838992
			291	Switch body ass'y, aluminum/nitrile	28A2890X012
			292*	O-ring, nitrile	1U2398X0032
			293*	O-ring, nitrile	11A8741X052
			294*	O-ring, nitrile	13A1584X012
			295	Switch body spring, K08500 (pl steel) (2 req'd)	18A2889X012

*Recommended spare parts

4195KA, KB, KC, and KS Controllers

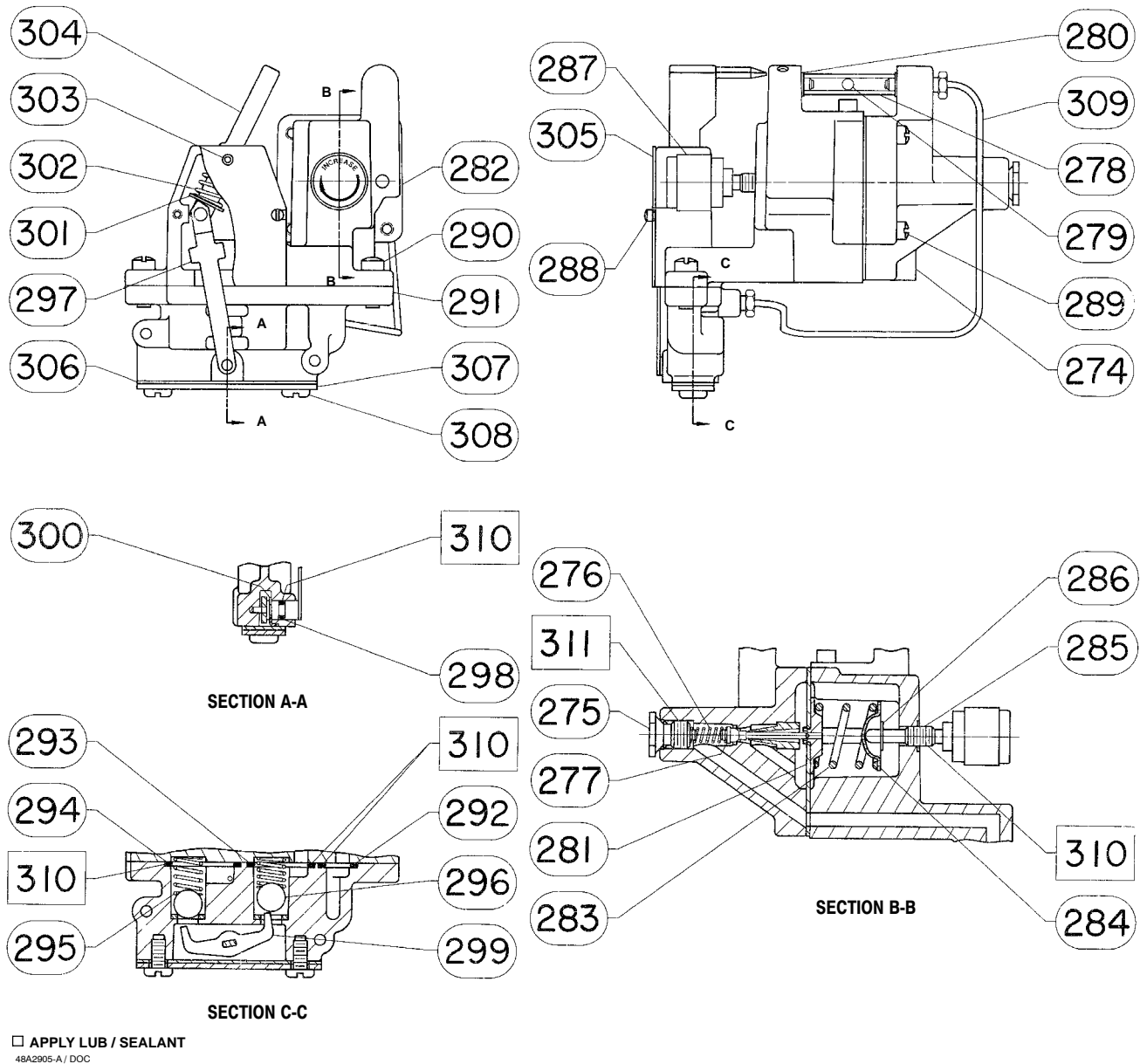

Figure 7-7. Auto/Manual Station Assembly

Key	Description	Part Number	Key	Description	Part Number
296	Ball, SST (2 req'd)	1J1550X0012	304	Switch lever, polycarbonate/SST	38A2897X012
297	Lever ass'y, SST	18A2866X012	305	Switch lever cover plate, aluminum/chromate	18A2873X012
298*	O-ring, nitrile	1E222606992	306*	Closing plate gasket, chloroprene	18A2898X012
299	Rocker, A96061 (aluminum)	18A2871X012	307	Closing plate, SST	18A2875X012
300	Clip, SST	18A2872X012	308	Machine screw, pan hd, 18-8 SST (2 req'd)	18A2899X022
301	Lever spring seat, SST	18A2870X012	309	Tubing ass'y, SST	28A2863X012
302	Lever spring, K08500 (pl steel)	18A2895X012	310	Lithium grease (not furnished with controller)	
303	Groove pin, SST	16A6380X012	311	Anti-seize sealant (not furnished with controller)	

Instruction Manual

Form 5207
April 2007

4195KA, KB, KC, and KS Controllers

Controller Mounting Parts

Key	Description	Part Number
-----	-------------	-------------

Note

Contact your Emerson Process Management sales office for any additional parts required for controller mounting.

Pipestand Mounting (figure 2-2)

66	Cap screw, hex hd, pl steel (3 req'd)	1A352624052
67	Lock washer, pl steel (7 req'd)	1C225728982
68	Bracket, pl steel	36A9755X012
69	Clamp, pl steel (2 req'd)	1P427028982

Pipestand Mounting with Regulator (figure 2-2)

66	Cap screw, hex hd, pl steel (3 req'd)	1A352624052
67	Lock washer, pl steel (7 req'd)	1C225728982
68	Bracket, pl steel	36A9755X012
69	Clamp, pl steel (2 req'd)	1P427028982
362	Cap screw, hex hd, pl steel (2 req'd)	T14109T0012
363	Lock washer, 18-8 SST (2 req'd)	1C225728982
364	Hex nut, A563 (pl steel) (2 req'd)	1A352724122
365	Tubing fittings (2 req'd)	See fittings subsection

Panel Mounting (figure 2-3)

66	Cap screw, hex hd, pl steel (3 req'd)	1A352624052
67	Lock washer, pl steel (3 req'd)	1C225728982
68	Bracket, A569 (pl steel)	36A6990X012
70	Machine Screw, rd hd, pl steel (4 req'd)	16A9763X012

Wall Mounting (figure 2-4)

66	Cap screw, pl steel (3 req'd)	1A352624052
67	Lock washer, pl steel (3 req'd)	1C225728982
68	Bracket, pl steel	36A6990X012

Controller Mounting Parts for Actuator With Casing- Mounted Controller

	Spacer spool, steel (3 req'd)	1C559024092
	Cap screw, hex hd, pl steel (3 req'd)	1B762424052
	Lock washer, pl steel (5 req'd)	1C225728982
	Mounting bracket, A569 (pl steel)	36A9754X012
	Cap screw, hex hd, pl steel (2 req'd)	1C379124052
	Mounting bracket, G10100 (pl steel) For 657/667 size 80 & 100	26A0350X012
	For all other types	1F401225072
	Cap screw, hex hd, pl steel (2 req'd)	1A368324052
	Hex nut, pl steel (2 req'd)	1E944024112
	Washer, pl steel (2 req'd)	1B865928982
	Washer, G10100 (pl steel) (2 req'd)	1H723125072

Key	Description	Part Number
-----	-------------	-------------

Controller Mounting Parts for Actuator With Yoke- Mounted Controller (figure 2-1)

	Spacer spool, steel (3 req'd)	1C559024092
	Cap screw, hex hd, pl steel (3 req'd)	1B762424052
	Lock washer, pl steel (5 req'd)	1C225728982
	Mounting bracket, steel For 1061 w/switches or manual operator	36A6991X012
	For all other types	36A9754X012
	Spacer spool, steel (2 req'd)	1J830724092
	Cap screw, hex hd, pl steel (2 req'd)	1A352524052

Regulator Mounting Parts

Regulator Mounting Parts for Casing-Mounted Regulator

	Cap screw, hex hd, pl steel (2 req'd)	1A582824052
	Lock washer, pl steel (2 req'd)	1C225728982
	Cap screw, hex hd, pl steel (2 req'd)	T14109T0012
	Hex nut, pl steel (2 req'd)	1A352724122
	Mounting bracket, G10100 (pl steel) For 657/667 size 80 & 100	26A0350X012
	For all other types	1F401225072

Regulator Mounting Parts for Yoke-Mounted Regulator (Mounting Bracket Not Required)

	Cap screw, hex hd, pl steel (2 req'd)	T14109T0012
	Lock washer, pl steel (2 req'd)	1C225728982

Regulator Mounting Parts for Yoke-Mounted Regulator (With Mounting Bracket)

	Cap screw, hex hd, pl steel (2 req'd)	1A381624052
	Lock washer, pl steel (4 req'd)	1C225728982
	Cap screw, hex hd, pl steel (2 req'd)	T14109T0012
	Hex nut, pl steel (2 req'd)	1A352724122
	Mounting bracket, G10100 (pl steel) For 1061, size 30, all shaft sizes	23A8891X012
	For all other types	1C221825022

4195KA, KB, KC, and KS Controllers

Fittings

Key	Description	Part Number	Key	Description	Part Number
				Fittings for 3/8-inch tubing, all controllers without regulator	
				Connector, brass (1 req'd)	1B885618992
				Elbow, brass (1 req'd)	1B884618992
				Fittings for 1/2-inch synthetic rubber hose, all controllers w/ or w/o regulator	
				Connector, 316 SST	15A6002XK32
				Elbow, 316 SST	15A6002XK12
				Swivel, 316 SST (2 req'd)	15A6002XK22
				Fittings for 3/8-inch tubing, casing- or yoke-mounted controller with regulator	
				Connector, brass (2 req'd)	1B885618992
				Elbow, brass (2 req'd)	1B884618992
				Fittings for 3/8-inch tubing, pipestand-mounted controller with regulator	
				Elbow, brass (2 req'd)	1B884618992

Note

The quantity shown make up the fitting for one end of the tubing or hose. Specify quantity of fittings required.

Fisher is a mark owned by Fisher Controls International LLC, a member of the Emerson Process Management business division of Emerson Electric Co. Emerson Process Management, Emerson, and the Emerson logo are trademarks and service marks of Emerson Electric Co. All other marks are the property of their respective owners.

The contents of this publication are presented for informational purposes only, and while every effort has been made to ensure their accuracy, they are not to be construed as warranties or guarantees, express or implied, regarding the products or services described herein or their use or applicability. We reserve the right to modify or improve the designs or specifications of such products at any time without notice.

Neither Emerson, Emerson Process Management, nor any of their affiliated entities assumes responsibility for the selection, use and maintenance of any product. Responsibility for the selection, use and maintenance of any product remains with the purchaser and end-user.

Emerson Process Management

Marshalltown, Iowa 50158 USA

Cernay 68700 France

Sao Paulo 05424 Brazil

Singapore 128461

www.Fisher.com

