

Chromalox®

Installation, Operation and MAINTENANCE INSTRUCTIONS

SERVICE REFERENCE	
DIVISION 4	SECTION MT
SALES REFERENCE (Supersedes PD407-17)	PD407-18
161-048381-001	
DATE	AUGUST, 2009

Industrial Screw Plug Immersion Heaters ARMT, ARMTO, ARMTS, ARMTI, AREMTI, AREMTO, AREMTS, CH-SD, EMT, EMTI, EMTO, EMTS, E4TP, MT, MTI, MTO, MTS, ARTM, ARTMO, ARTMS & ARTMI

Note: These instructions relate to all enclosure styles shown within.

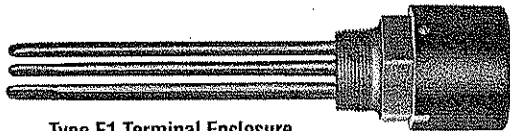

Type E1 Terminal Enclosure
General Purpose (Rotatable)

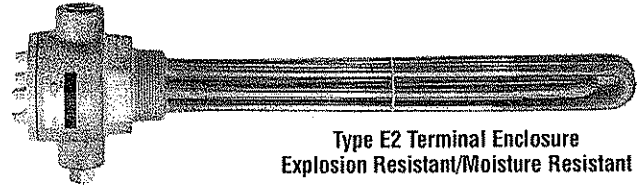

Type E2 Terminal Enclosure
Explosion Resistant/Moisture Resistant

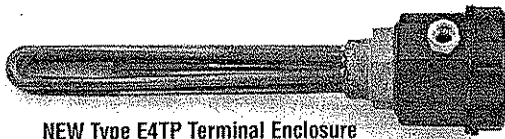

NEW Type E4TP Terminal Enclosure

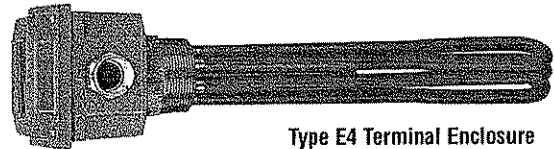

Type E4 Terminal Enclosure
Moisture Resistant

GENERAL

Chromalox type ARMT, ARMTO, ARMTS, ARMTI, AREMTI, AREMTO, AREMTS, CH-SD, EMT, EMTI, EMTO, EMTS, E4TP, MT, MTI, MTO, MTS, ARTM, ARTMO, ARTMS and ARTMI screw plug immersion heaters are designed for a wide variety of heating applications.

Heater Construction Characteristics:

- High quality resistance wire held in place by compacted Magnesium Oxide Refractory enclosed in a wide variety of sheath materials.
- Low to high watt densities.
- Standard selection of sheath materials include copper, steel, INCOLOY® alloy and stainless steel. This broad selection of sheath materials will operate successfully in many corrosive solutions.
- Proper selection of sheath material is the sole responsibility of the customer.
- Units are available with E1 General Purpose, E4 Moisture Resistant and E2/E3 Explosion/Moisture-Resistant terminal enclosures.

Additional enclosure styles available but not shown above.

⚠ WARNING

IMPORTANT: It is the responsibility of the purchaser of the heater to make the ultimate choice of sheath material based upon his/her knowledge of the chemical composition of the corrosive solution, character of the materials entering the solution, and controls which he/she maintains on the process.

⚠ WARNING

Sheath corrosion can result in a ground fault which, depending upon the solution being heated, can cause an explosion or fire.

⚠ WARNING

The system designer is responsible for the safety of this equipment and should install adequate back-up controls and safety devices with their electric heating equipment. Where the consequences of failure could result in personal injury or property damage, back-up controls are essential.

⚠ WARNING

FIRE HAZARD. An integral thermostat, if provided, is designed for temperature control service only. Because the thermostat does not fail safe, it should not be used for temperature limiting duty. Wiring to this device is the responsibility of the user.

INSTALLATION

⚠ WARNING

ELECTRIC SHOCK HAZARD. Disconnect all power before installing or servicing heater. Failure to do so could result in personal injury or property damage. Heater must be installed by a qualified person in accordance with the National Electrical Code, NFPA 70.

1. Before installing, unpack and check your immersion heater for any damage that may have occurred during shipment. Report any claims to your carrier if damage has occurred in shipment. **Do not operate damaged equipment. Consult factory for instructions.**
2. Check to ensure that the line voltage is the same as that stamped on the nameplate. Verify wattage and capacity versus the requirements at installation site.
3. Do not bend the heating elements. If bending is necessary, consult factory.
4. **IMPORTANT:** Mount the heater in the tank so that the liquid level will always be above the effective heated portion of the heater. If the heater is not properly submerged, it may overheat and damage the heating elements (see Figure 1).

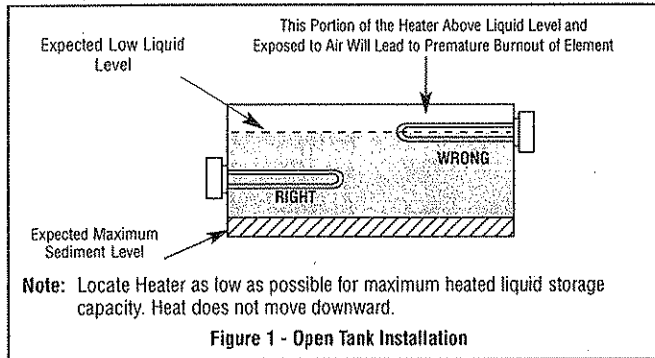

5. Where work will pass over or near equipment, additional protection such as a metal guard may be needed.
6. Heater shall not be operated in sludge.

⚠ WARNING

FIRE HAZARD. If the heater is not properly submerged, the heating elements will overheat and could result in a fire or damaged equipment.

7. Install the heater using a high quality pipe sealing compound on the threads. Screw the heater into the opening (Figure 2). Tighten sufficiently with wrench applied on the hex portion of the screwplug.

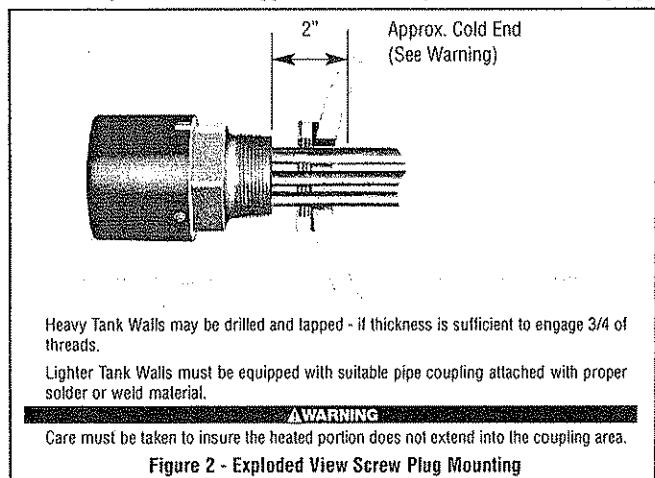

8. Closed Tank Installation

⚠ WARNING

EXPLOSION HAZARD. When heating in closed vessels, controls and back-up controls must be used to regulate build-up of temperature and/or pressure.

A. Horizontal Position (Figure 3)

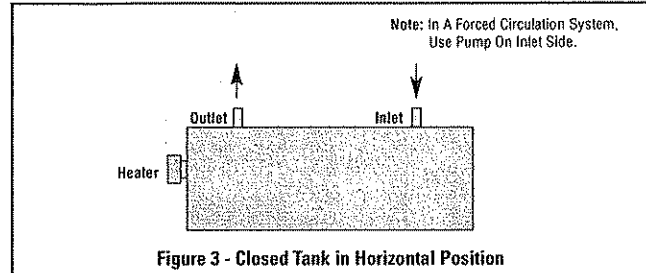

- A1. Place heater at an elevation so that natural circulation can take place.
- A2. Position outlet and inlet in a vertical plane, facing upward to prevent air pockets. Be sure all trapped air is removed from the closed tank. Bleed the air out of the liquid piping system and heater enclosure prior to operation.
- A3. **IMPORTANT:** Heater should never be located at the highest point of the liquid system. Provide expansion tank, if necessary.
- A4. Heater shall be supported if the immersion length is greater than 36".

⚠ CAUTION

FREEZE HAZARD. This unit may be equipped with a thermowell for process control or over-temperature control. Do not allow moisture to accumulate in thermowell. Freezing temperatures can cause damage that may result in the heated medium leaking into terminal closure.

B. Vertical Position (Figure 4)

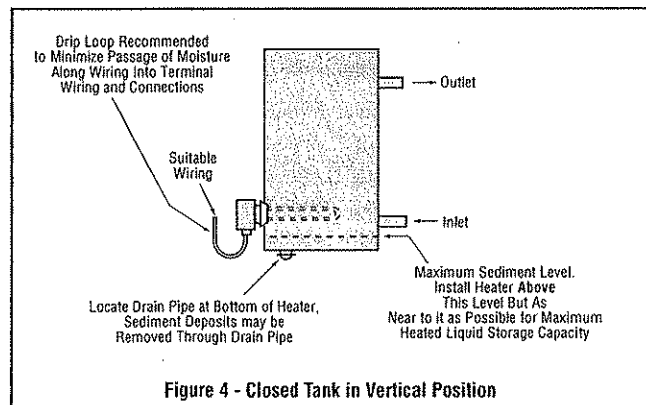

A drip loop is recommended to minimize passage of moisture from condensation along wiring into terminal enclosure and connections.

9. To prevent moisture accumulation in cryogenic applications or when heater is exposed to freezing temperatures:
 - A. Slope conduit away from enclosure (drip loop).
 - B. Seal all conduit openings to moisture/explosion resistant terminal enclosure.
 - C. Insulate terminal enclosure.
 - D. Fill thermowell(s) with silicone, fluid when heater is mounted with terminal enclosure up.

INSTALLATION (cont'd.)

⚠ WARNING

10. **FIRE HAZARD.** Since heaters are capable of developing high temperatures, extreme care should be taken to:

- Use explosion-resistant terminal enclosures in hazardous locations. See Chromalox catalog for specification of explosion-resistant terminal enclosures for hazardous locations. All options not shown here.
- Avoid contact between heaters and combustible material.
- Keep combustible materials far enough away to be free of the effects of high temperatures.

⚠ WARNING

Provisions should be made to prevent damage from any eventual leaking of tank or components. Failure to comply could result in personal injury or property damage.

- Adjustment Instructions for E1 Enclosure only (Figure 5).
 - After tightening the heater into the tank opening, the terminal enclosure can be rotated to a more convenient position to install the power feed.
 - Remove the terminal box cover (Item A) by loosening the three cover screws (Item B) (do not completely remove the screws since the cover holes are open slotted).
 - To rotate the terminal enclosure, loosen the three mounting screws (Item C) until the base rotates freely (do not completely remove).
 - Turn the base until the conduit opening is at the desired position.
 - Tighten the base mounting screws securely (Item C).
 - Caution: Do not over tighten.**
 - Follow the rest of the screw plug installation instructions to complete the installation

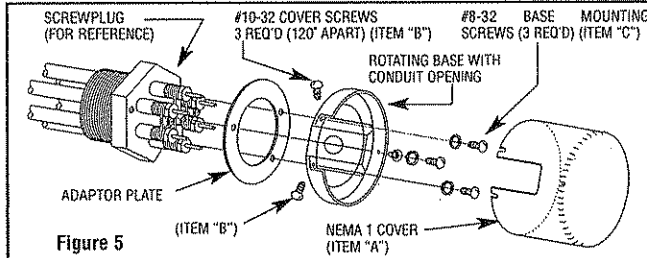

⚠ WARNING

FIRE OR SHOCK HAZARD: Moisture accumulation in the element refractory material, element over-temperature, or sheath corrosion can cause ground fault to the element sheath, generating arcing and molten metal. Install Ground Fault Circuit-Interrupter (GFCI) to prevent personal injury or Equipment Ground Fault Protection to prevent property damage.

- Adjustment Instructions for E4TP Enclosure only (Figure 6).
 - After tightening the heater into the tank opening, the terminal enclosure can be rotated to a more convenient position to install the power feed.
 - Remove the lid by loosening the set screw and giving the lid a 1/4 turn twist off motion. After lid removal, loosen the nuts holding the clamp down plate against the inside enclosure lip and turn to the desired position.
 - Tighten nuts and secure enclosure.
 - For maximum flexibility and optimal moisture resistant performance of the large Buna O-ring gasket, the gasket should be lubricated with an inert lubricant such as silicone or while lithium based product.

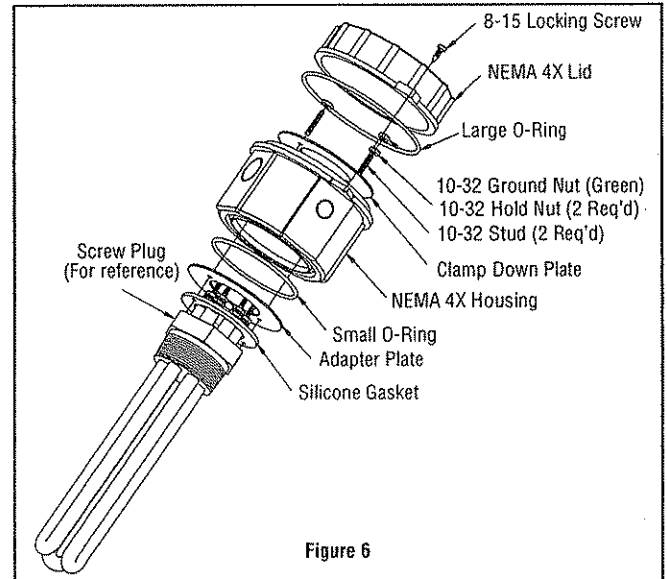

THERMOSTATS

- Integrally mounted thermostats are available.
- Thermostats may be connected directly to heaters that are rated within the electrical capacities. When the heater amperage exceeds the contact rating of the thermostat, the heater should be controlled

by a magnetic contactor with the thermostat wired for pilot duty. Refer to the thermostat instruction sheet packed with the heater. If one isn't provided, please contact Chromalox for ratings.

WIRING

⚠ WARNING

ELECTRIC SHOCK HAZARD. Disconnect all power before installing or servicing heater. Failure to do so could result in personal injury or property damage. Heater must be installed by a qualified person in accordance with the National Electrical Code, NFPA 70.

⚠ WARNING

ELECTRIC SHOCK HAZARD. Any installation involving electric heaters must be performed by a qualified person and must be effectively grounded in accordance with the National Electrical Code to eliminate shock hazard.

1. Electric wiring to heater must be installed in accordance with the National Electrical Code and with local codes by a qualified person. **WARNING: Use copper conductors only.**
2. When element wattages are not equal, heaters must not be connected in series.
3. Electrical wiring to heater should be contained in rigid conduit or

- in sealed flexible hose to keep corrosive vapors and liquids out of the terminal enclosure. If high humidity is encountered, the conduit should slope down away from the heater.
4. If flexible cord is employed, a moisture resistant connector should be used for entry of the cord into the terminal enclosure. Outdoor applications require moisture resistant conduit and connectors.
5. Bring the power line wires through the opening in the terminal enclosure. Connect line wires as shown in the wiring diagrams. (See Figures 7 thru 13.)
6. Check for loose terminal connections and tighten if necessary. Made to order items are prewired and tagged at the factory. Wiring of made to order items may differ from those shown in the tabulation. Carefully check voltage and phase on the heater nameplate and select either the appropriate wiring shown above or check for the appropriate wiring diagram in the heater terminal enclosure. For reference purposes, some typical wiring diagrams are shown in the following figures.
7. The current carrying capacity of the power supply leads should exceed the heater amperage by at least 25%. Be sure to consider the ambient operating temperature and apply the appropriate correction factor to the ampacity rating of the wire. Heaters with the same voltage and wattage may be connected in series for operation at a higher voltage.

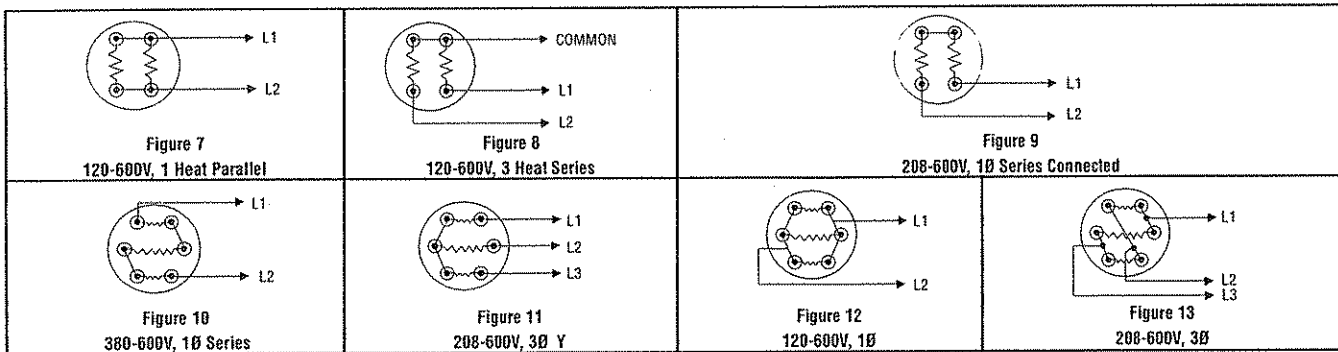

SPECIAL REQUIREMENTS

Wiring

Use only Type E2/E3 terminal enclosures in hazardous location environments. The proper use of Type E2/E3 terminal enclosures on electric heaters located in hazardous areas requires that all electrical wiring comply with National Electrical Code (NEC) requirements for hazardous locations.

Maximum Temperatures

Safe operation in a hazardous location requires the maximum operating temperatures of all exposed surfaces of the heater including temperatures on the outside of the vessel, piping, flanges, screw plugs, enclosures and other heat conducting parts be limited. The flammable liquids, vapors or gases present determine the maximum

surface temperature permitted in any hazardous location. The end user or purchaser of the electric heating equipment is responsible for determining the proper classification of an area and for providing Chromalox with hazardous area specifications and requirements for proper equipment design. (NEC Articles 500 and 501 provide guidelines for evaluating and classifying hazardous locations.)

Safety Devices

Approved pressure and/or temperature limiting controls must be used on electric heaters and heating elements to ensure safe operation in the event of system malfunctions.

Note: Class I Group B locations include Hydrogen gas. These areas require additional conduit seals and thread engagement.

OPERATION

1. Do not operate heaters at voltages in excess of that stamped on the heater since excess voltage will shorten heater life.
2. Always maintain a minimum of 2" of liquid above the heated portion of the element to prevent exposure of the effective heated length. If the heater is not properly submerged, it may overheat and damage heating elements, tank or contents.

IMPORTANT: Mount heater in the tank so the liquid level will always be above the effective heated portion of the heater. Provide expansion tank if necessary.

WARNING

If the heater is not properly submerged, the heating elements will overheat and could result in a fire or damaged equipment.

3. Be sure all trapped air is removed from a closed tank. Bleed the air out of the liquid piping system and heater housing prior to energizing.
Note: The tank or heating chamber in closed tank systems must be kept filled with liquid at all times.
4. Keep heating elements above sediment deposits.

5. **Low Megohm Condition** — The refractory material used in electric heaters may absorb moisture during transit, storage or when subject to humid environments that will reduce the cold insulation resistance (low megohm). Low megohm may result in high leakage current to ground and nuisance trips of ground fault protection equipment. Normally, the megohm value increases after heat-up.

Typical insulation values are 5 megohm or greater on complete assemblies of unsealed elements or 20 megohm on individual unsealed elements. It is recommended that heaters with 1 megohm or less be dried out before applying full power. If dried properly low megohm will not effect heater life or efficiency.

To correct a low megohm condition, remove terminal enclosure cover, gaskets, and terminal hardware. Bake heaters in an oven at 300 to 350°F for several hours or preferably overnight.

An alternate procedure is to cycle the heater in 10 to 15 minute periods at low voltage until megohm values are normal. Sheath temperatures should not exceed 350°F.

Note: Low megohm on heating elements with epoxy or hermetic seals cannot be serviced in the field. Typical resistance values when sealed are 200 megohm or greater. Contact Chromalox service center at number listed.

MAINTENANCE

WARNING

ELECTRIC SHOCK HAZARD. Disconnect all power before installing or servicing heater. Failure to do so could result in personal injury or property damage. Heater must be installed by a qualified person in accordance with the National Electrical Code, NFPA 70.

1. Heaters should be checked regularly for coatings and corrosion and cleaned if necessary.
2. The tank should be checked regularly for sediment around the heater as sediment can act as an insulator and shorten heater life.
Note: applies to all items, not just # 2.
Note: User is responsible for maintenance schedule based on their knowledge of the heated medium and operating conditions.
3. Remove any accumulated sludge deposits from heater and from tank.
4. Check for loose terminal connections and tighten if necessary.
5. If corrosion is indicated in the terminal enclosure, check terminal enclosure gasket and replace if necessary. Check conduit layout to correct conditions that allow moisture to enter the terminal enclosure.
6. Clean terminal ends of all contamination.
7. The heater can be protected from possible mechanical damage by placing a screen or grill around the elements.
8. Protect the terminal end of the heater from spray, condensation, dripping and vapors. A protective terminal enclosure should be used if the heater is to be subjected to these conditions.

9. If the heater is to be operated in the presence of explosive vapors or dust, an explosion resistant terminal enclosure must be provided.
10. Do not set the thermostats above the boiling point of the liquid. The boiling liquid could create a steam pocket which could cause the element(s) to overheat and burn out.
11. Periodically, remove the heater from the tank to inspect the elements for signs of corrosion and remove any deposits from the sheath. **BE SURE POWER IS DISCONNECTED BEFORE REMOVING ELEMENTS.**
12. Be sure the sheath material is compatible with the material being heated. Copper sheathed elements are used to heat oil, alkaline, wax and other similar materials. Stainless steel and Incoloy sheathed elements are most often used for heating water and corrosive solutions. Check with the supplier of the material or factory for a recommendation of a suitable sheath material.
13. Make sure the watt-density of the heater is suitable for the material being heated. The velocity, viscosity, thermal conductivity of the material and operating temperature are all factors in determining the allowable watt-density of the element. Consult factory if in doubt about the proper watt-density for the heater in a particular application.
14. When heating liquids in a large tank, the use of several small heaters will provide more uniform heat distribution than a single large heater.

Note: User is responsible for maintenance schedule based on their knowledge of the heated medium and operating conditions.

WARRANTY AND LIMITATION OF REMEDY AND LIABILITY

Chromalox warrants only that the Products and parts manufactured by Chromalox, when shipped, and the work performed by Chromalox when performed, will meet all applicable specification and other specific product and work requirements (including those of performance), if any, and will be free from defects in material and workmanship under normal conditions of use. All claims for defective or nonconforming (both hereinafter called defective) Products, parts or work under this warranty must be made in writing immediately upon discovery, and in any event, within one (1) year from delivery, provided, however all claims for defective Products and parts must be made in writing no later than eighteen (18) months after shipment by Chromalox. Defective and nonconforming items must be held for Chromalox's inspections and returned to the original f.o.b. point upon request. THE FOREGOING IS EXPRESSLY IN LIEU OF ALL OTHER WARRANTIES WHATSOEVER, EXPRESS, IMPLIED AND STATUTORY, INCLUDING, WITHOUT LIMITATION, THE IMPLIED WARRANTIES OF MERCHANTABILITY AND FITNESS FOR A PARTICULAR PURPOSE.

Notwithstanding the provisions of this WARRANTY AND LIMITATION Clause, it is specifically understood that Products and parts not manufactured and work not performed by Chromalox are warranted only to the extent and in the manner that the same are warranted to Chromalox by Chromalox's vendors, and then only to the extent that Chromalox is reasonably able to enforce such warranty, it being understood Chromalox shall have no obligation to initiate litigation unless Buyer undertakes to pay all cost and expenses therefor, including but not limited to attorney's fees, and indemnifies Chromalox against any liability to Chromalox's vendors arising out of such litigation.

Upon Buyer's submission of a claim as provided above and its substantiation, Chromalox shall at its option either (i) repair or replace its Products, parts or work at the original f.o.b. point of delivery or (ii) refund an equitable portion of the purchase price.

THE FOREGOING IS CHROMALOX'S ONLY OBLIGATION AND BUYER'S EXCLUSIVE REMEDY FOR BREACH OF WARRANTY, AND IS BUYER'S EXCLUSIVE REMEDY AGAINST CHROMALOX FOR ALL CLAIMS ARISING HEREUNDER OR RELATING HERETO WHETHER SUCH CLAIMS ARE BASED ON BREACH OF CONTRACT, TORT (INCLUDING NEGLIGENCE AND STRICT LIABILITY) OR OTHER THEORIES. BUYER'S FAILURE TO SUBMIT A CLAIM AS PROVIDED ABOVE SHALL SPECIFICALLY WAIVE ALL CLAIMS FOR DAMAGES OR OTHER RELIEF, INCLUDING BUT NOT LIMITED TO CLAIMS BASED ON LATENT DEFECTS. IN NO EVENT SHALL BUYER BE ENTITLED TO INCIDENTAL OR CONSEQUENTIAL DAMAGES AND BUYER SHALL HOLD CHROMALOX HARMLESS THEREFROM. ANY ACTION BY BUYER ARISING HEREUNDER OR RELATING HERETO, WHETHER BASED ON BREACH OF CONTRACT, TORT (INCLUDING NEGLIGENCE AND STRICT LIABILITY) OR OTHER THEORIES, MUST BE COMMENCED WITHIN ONE (1) YEAR AFTER THE DATE OF SHIPMENT OR IT SHALL BE BARRED.

W2008M

Chromalox®

PRECISION HEAT AND CONTROL

2150 N. RULON WHITE BLVD., OGDEN, UT 84404
Phone: 1-800-368-2493 www.chromalox.com