

REVISION HISTORY							
ZONE	REV	ECN	DESCRIPTION	DATE	DR	CHK	APPD

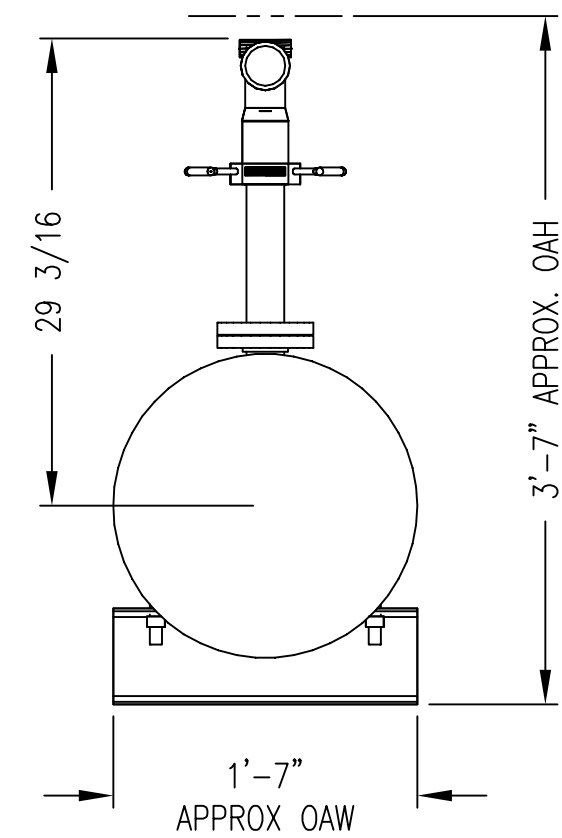
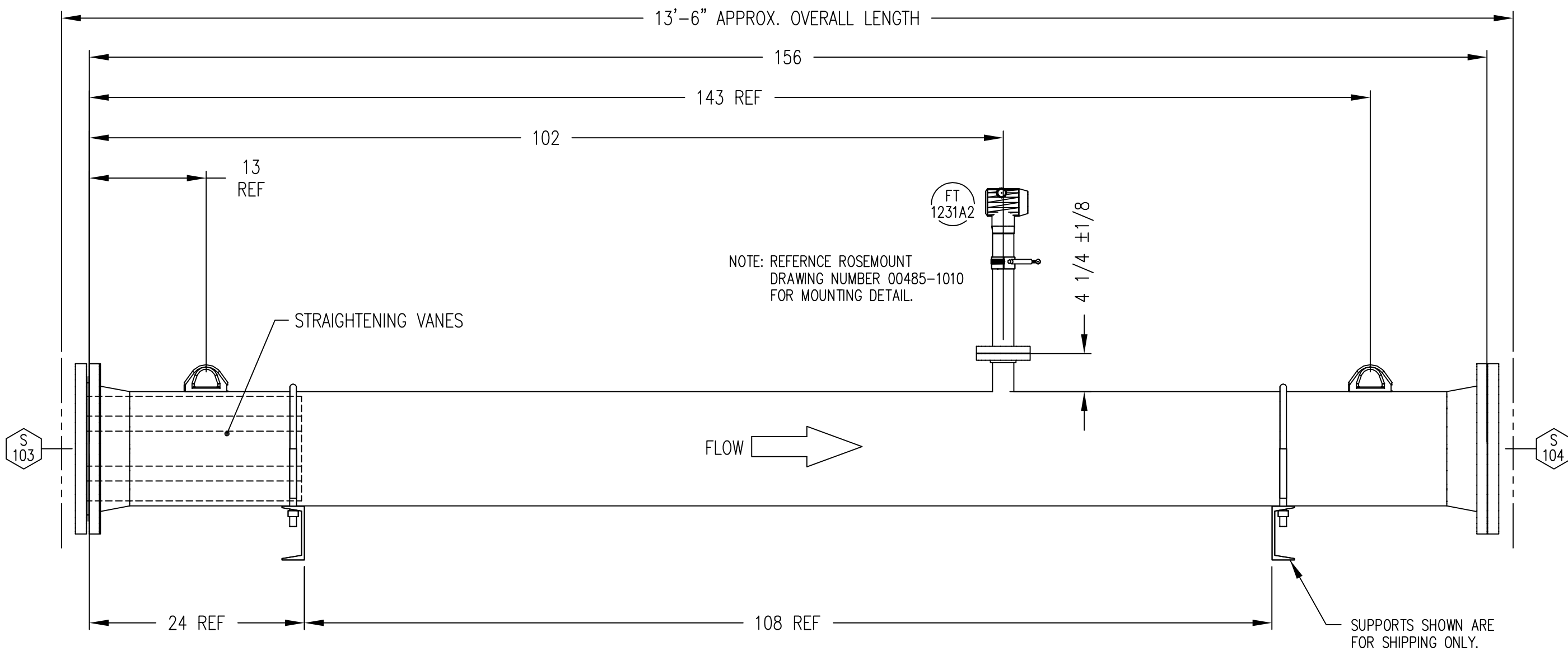

- NOTES:
- REFERENCE DRAWINGS:  
P & I DIAGRAM, (6) REFRIGERATION COMPRESSOR UNITS: 659D2149
  - AREA CLASSIFICATION:  
OUTDOOR UNDER ROOF, HAZARDOUS, NEMA 4X, CL 1, GR C&D, DIV II
  - MAJOR PIPING CUSTOMER CONNECTIONS ARE LISTED IN CHART. AUXILIARY CONNECTIONS (E.G. PNEUMATIC, ELECTRIC, RELIEF VENT, ETC.) ARE NOT LOCATED. REFER TO REFERENCE DRAWING, ETC., FOR ADDITIONAL INFORMATION.
  - SPECIAL INSTALLATION INSTRUCTIONS FOR ERECTING ENGINEER APPLY. REFER TO DRAWING 560D0124.
  - CUSTOMER CONNECTION DIMENSION TOLERANCE:  $\pm 1/2$ , UNLESS NOTED.
  - NOTES FOR FABRICATION SHOP:  
FABRICATE AND TEST IN ACCORDANCE WITH FABRICATION NOTES DRAWING 560D0132 AS MODIFIED BELOW.

PAINT AS FOLLOWS:	COLOR	MIN. # COATS	THK/COAT
AMERLOCK 400	GR 2	1	3 MILS NOM
AMERCOAT 450HS	GR 2	1	2 MILS NOM
COMBINED MINIMUM DRY FILM THICKNESS = 5 MILS			

- CAUTION: PACKAGE MUST BE GROUNDED DURING PAINT PROCEDURE.  
SPECIAL REQUIREMENTS:
- TAG NUMBERS SHOWN ARE FOR PHASE 1 UNIT A, REPLACE "A" WITH A,B,C,D,E,F FOR UNIT A,B,C,D,E,F. REPLACE "1231" WITH 1331 FOR PHASE II. EX: FT-1231A2 IS PHASE I UNIT A, FT-1331C2 IS PHASE II UNIT C.
  - DUE TO SPACE CONSTRAINTS IMPOSED ON THIS PROJECT, EXTRAORDINARY MEASURES MAY BE NECESSARY FOR INSULATION AND/OR SERVICE ACCESS.
  - ALL PERMANENT PIPE, PIPE FITTING, TUBING AND TUBE FITTINGS TO HAVE MATERIAL OF ORIGIN RESTRICTIONS PER AES 1100.04
  - USE 1-1 PIPE. FCAW IS PROHIBITED

CONNECTION LEGEND			
CONN	SIZE	DESCRIPTION	QTY
S-103	12"-CL 150 ANSI FLANGE	FLOW SPOOL INLET	1
S-104	12"-CL 150 ANSI FLANGE	FLOW SPOOL OUTLET	1

APPLICABLE PIPING CODE	ANSI B31.3
RADIOGRAPHY	5%

DESCRIPTION	SPOOL PIPING
DESIGN WORKING PRESSURE	200 PSI
PROOF TEST PRESSURE	220 PSI
LEAK TEST PRESSURE	200 PSI

ESTIMATED WEIGHT: 1500 LBS

**APPROVAL DRAWINGS**  
IN ORDER TO MEET THE DELIVERY ON THE SUBJECT ORDERS, COMMENTS TO THE ATTACHED DOCUMENTS MUST BE RETURNED WITHIN TEN (10) WORKING DAYS

PURCHASER SANDRIDGE ENERGY 1601 N.W. EXPRESSWAY SUITE 1600 OKLAHOMA CITY, OK 73118		NOTICE TO PURCHASER REFER TO CONTRACT FOR MATERIAL TO BE SUPPLIED BY YORK REFRIGERATION. THE AMOUNT OF SUCH MATERIAL IS NOT INCREASED BY ANYTHING SHOWN UPON THIS DRAWING.	
YORK ORD NO 294100		PURCH ORD NO 27607-P-13-012JCI	
UNLESS OTHERWISE SPECIFIED DIMENSIONS ARE IN INCHES DO NOT SCALE		100 CV AVENUE WAYNESBORO, PA 17268 USA 	
UNLESS OTHERWISE SPECIFIED TOLERANCES PER QAP 18		TITLE GENERAL ARRANGEMENT 12" INTERCONNECTING PIPING FLOW ELEMENT SPOOL	
DR J SMITH 6/12/09		SIZE C	CAGE CODE 23587
CHK T PALMER 6/15/09		DWG NO 569C1623	REV
APPD T PALMER 6/15/09		SCALE 1:12	SHEET 1 OF 1
CODE			