



BY JOHNSON CONTROLS

OM TITAN™ MULTI-STAGE CHILLER

SERVICE INSTRUCTIONS

NEW RELEASE

Form 160.72-M1 (810)

TITAN™ MULTISTAGE CHILLER WITH RETROFIT OPTIVIEW CONTROL CENTER KIT AND ELECTRO-MECHANICAL STARTER

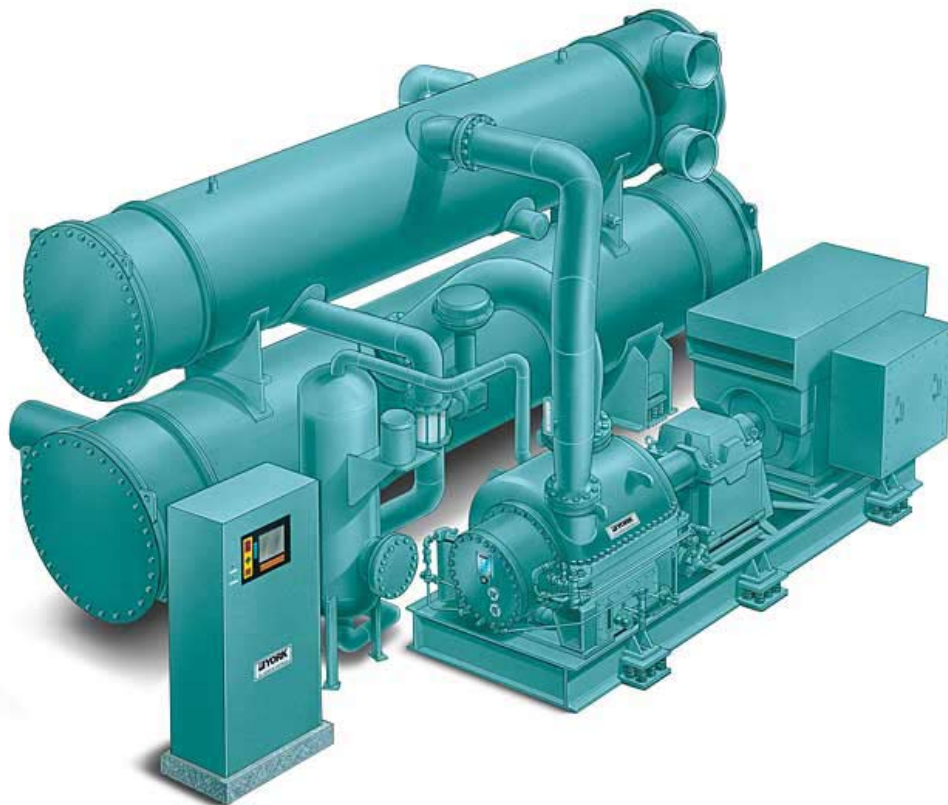

IMPORTANT!

READ BEFORE PROCEEDING!

GENERAL SAFETY GUIDELINES

This equipment is a relatively complicated apparatus. During installation, operation maintenance or service, individuals may be exposed to certain components or conditions including, but not limited to: refrigerants, materials under pressure, rotating components, and both high and low voltage. Each of these items has the potential, if misused or handled improperly, to cause bodily injury or death. It is the obligation and responsibility of operating/service personnel to identify and recognize these inherent hazards, protect themselves, and proceed safely in completing their tasks. Failure to comply with any of these requirements could result in serious damage to the equipment and the property in

which it is situated, as well as severe personal injury or death to themselves and people at the site.

This document is intended for use by owner-authorized operating/service personnel. It is expected that this individual possesses independent training that will enable them to perform their assigned tasks properly and safely. It is essential that, prior to performing any task on this equipment, this individual shall have read and understood this document and any referenced materials. This individual shall also be familiar with and comply with all applicable governmental standards and regulations pertaining to the task in question.

SAFETY SYMBOLS

The following symbols are used in this document to alert the reader to specific situations:



Indicates a possible hazardous situation which will result in death or serious injury if not proper care is not taken.



Identifies a hazard which could lead to damage to the machine, damage to other equipment and/or environmental pollution if proper care is not taken or instructions and are not followed.



Indicates a potentially hazardous situation which will result in possible injuries or damage to equipment if proper care is not taken.

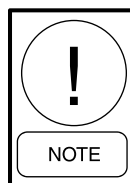

Highlights additional information useful to the technician in completing the work being performed properly.



External wiring, unless specified as an optional connection in the manufacturer's product line, is not to be connected inside the OptiView cabinet. Devices such as relays, switches, transducers and controls and any external wiring must not be installed inside the micro panel. All wiring must be in accordance with Johnson Controls' published specifications and must be performed only by a qualified electrician. Johnson Controls will NOT be responsible for damage/problems resulting from improper connections to the controls or application of improper control signals. Failure to follow this warning will void the manufacturer's warranty and cause serious damage to property or personal injury.

CHANGEABILITY OF THIS DOCUMENT

In complying with Johnson Controls' policy for continuous product improvement, the information contained in this document is subject to change without notice. While Johnson Controls makes no commitment to update or provide current information automatically to the manual owner, that information, if applicable, can be obtained by contacting the nearest Johnson Controls Service office.

Operating/service personnel maintains the responsibility of the applicability of these documents to the competitive equipment the kit is installed on. If there is any question regarding the applicability of these documents, the technician should verify whether the equipment has been modified and if current literature is available with the owner of the equipment prior to performing any work on the chiller.

ASSOCIATED LITERATURE

MANUAL DESCRIPTION	FORM NUMBER
Operating Instructions for YORK Titan Multi-Stage Chiller with Retrofit OptiView Controls	160.72-O1
Renewal Parts for YORK Titan Multi-Stage Chiller with Retrofit OptiView Controls	160.72-RP1

NOMENCLATURE

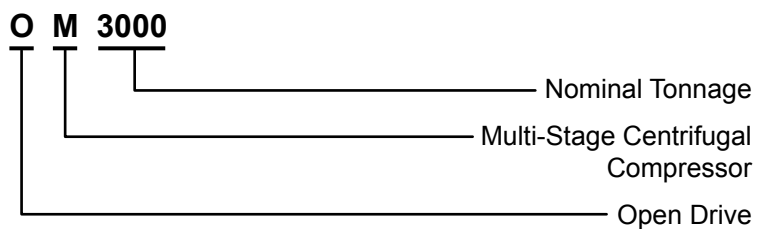

THIS PAGE INTENTIONALLY LEFT BLANK.

TABLE OF CONTENTS

SECTION 1 - INTRODUCTION	9
SECTION 2 - SYSTEM ARCHITECTURE	11
SECTION 3 - MICROBOARD 031-01730-000	19
Boot-Up Step And Description.....	20
Power Supply	24
Service Replacement	24
Program Jumpers.....	28
Program Switches	30
SECTION 4 - MICROBOARD 031-02430-000 AND 031-02430-001	35
Downloading A Program From A Program Card.....	44
Program Jumpers.....	46
Program Switches	47
SECTION 5 - I/O BOARD	55
Relay Timing.....	55
SECTION 6 - LIQUID CRYSTAL DISPLAY	63
Backlight Lamp Replacement.....	65
SECTION 7 - DISPLAY INTERFACE BOARD	71
SECTION 8 - DISPLAY BACKLIGHT INVERTER BOARD	75
SECTION 9 - KEYPAD	79
SECTION 10 - POWER SUPPLY	83
SECTION 11 - CURRENT MODULE (CM-2)	85
SECTION 12 - COMMUNICATIONS	89
SECTION 13 - PRESSURE TRANSDUCERS	91
SECTION 14 - TEMPERATURE TRANSMITTERS	93
SECTION 15 - REMOTE SETPOINTS	95
Current Limit.....	95
Leaving Chilled Liquid Temperature	97
SECTION 16 - HOT GAS BYPASS	101
Operation.....	101
SECTION 17 - SURGE PROTECTION	103
SECTION 18 - SYSTEM CALIBRATION, SERVICE SETPOINTS AND RESET PROCEDURES	105
Electro-Mechanical Starter Applications.....	105
Refrigerant Level Control	106
Hot Gas Bypass Control.....	108
Interstage Valve A Or B	109
Vane Control.....	109
Demand Control	110
Chiller Starts And Operation Hours Reset.....	111
Service Phone Numbers	111
Surge Protection.....	111
Sales Order Data.....	112
Custom User Id And Passwords.....	113
Flow Switches	113

TABLE OF CONTENTS (CONT'D)

SECTION 19 - DIAGNOSTICS AND TROUBLESHOOTING	115
Diagnostics Screen	116
Main Diagnostics Screen.....	117
Keypad Test.....	118
Procedure.....	118
Troubleshooting.....	118
Display Test Main Screen.....	119
Procedure.....	119
Bit Patterns Test Screen.....	121
Troubleshooting.....	121
Serial Inputs / Outputs Test Screen.....	123
Procedure.....	123
Digital Inputs / Outputs Test Screen.....	125
Procedure.....	125
Analog Inputs Test Screen.....	128
SECTION 20 - SYSTEM COMMISSIONING.....	131
Chiller Starting and Stopping Procedure.....	136
General.....	136
Pre-Start Compressor Check.....	136
Checking The Oil Level.....	136
Unit Start-Up.....	136
Stopping Unit.....	137

LIST OF FIGURES

FIGURE 1 - Optiview Control Center - Compressor Motor Electro-Mechanical Starter (EM)	14
FIGURE 2 - Optiview Control Center - Compressor Motor Variable Speed Drive (Modbus Serial Communications Protocol)	15
FIGURE 3 - Optiview Control Center - Compressor Motor Medium Voltage Variable Speed Drive	16
FIGURE 4 - Operation Sequence Timing Diagram (Electro-Mechanical And Solid State Starter Applications)	17
FIGURE 5 - Microboard 031-01730-000	25
FIGURE 6 - Flash Memory Card	26
FIGURE 7 - Microboard (031-01730-000) Power Supply Test Points	27
FIGURE 8 - Microboard Lamp Dimmer Circuit	32
FIGURE 9 - Microboard Serial Data Communications Ports	33
FIGURE 10 - Configurable Analog And Remote Setpoint Inputs	34
FIGURE 11 - BRAM Socket	43
FIGURE 12 - Microboard 031-02430-000 and 031-02430-001	48
FIGURE 13 - Program Card 031-02474-001	49
FIGURE 14 - Microboard (031-02430-000 And 031-02430-001) Dc Power Supply Test Points	49
FIGURE 15 - Microboard Lamp Dimmer Circuit	50
FIGURE 16 - Microboard Serial Data Communications Ports	51
FIGURE 17 - Configurable Analog And Remote Setpoint Inputs	52
FIGURE 18 - Low Voltage Digital Inputs	53
FIGURE 19 - I/O Board	57
FIGURE 20 - I/O Board Digital Inputs	58
FIGURE 21 - I/O Board Typical Opto-Coupler Circuit	59
FIGURE 22 - I/O Board Typical Field Connections	59
FIGURE 23 - J1 I/O Board Digital Outputs	60
FIGURE 24 - J1 I/O Board Digital Outputs	61
FIGURE 25 - Display Mounting	66
FIGURE 27 - Liquid Crystal Display Assembly – Sharp LQ10D367/368 (031-01774-000) Display	67
FIGURE 26 - Liquid Crystal Display Assembly – Sharp LQ104V1DG61 (031-02886-000) Display	67
FIGURE 28 - Liquid Crystal Display Assembly - Lg Semicon LP104V2-W (031-02046-000)	68
FIGURE 29 - Liquid Crystal Display Typical Control Signal Timing	68
FIGURE 30 - Display (Sharp LQ10D367/368) Lamp Replacement	69
FIGURE 31 - Display (Sharp LQ104V1DG61 (031-02886-000) and LG LP104V2-W (031-02046-000))	69
FIGURE 32 - Display Interface Board 031-01765-001 and 031-01765-002	72
FIGURE 33 - Display Interface Board 031-02887-000	73
FIGURE 34 - Display Backlight Inverter Board (Sharp LQ10D367/368 (031-01774-000) and LG Semicon LP104V2-W (031-02046-000))	76
FIGURE 35 - Display Backlight Inverter Board - Sharp LQ104V1DG61 Display 031-02886-000	77
FIGURE 36 - Keypad	80
FIGURE 37 - Keypad	81
FIGURE 38 - Power Supply	83
FIGURE 39 - Power Supply – Dc Power Distribution	84
FIGURE 40 - CM-2 Current Module (Electro-Mechanical Starter Application)	87
FIGURE 41 - CM-2 Current Module (Electro-Mechanical Starter Applications)	87
FIGURE 42 - CM-2 Current Module – Interface, Current Transformers And Variable Resistors	88
FIGURE 43 - E-Link Gateway Interface Block Diagram	89
FIGURE 44 - Pressure Transducers	92
FIGURE 45 - Diagnostics Screen	116
FIGURE 46 - Main Diagnostics Screen	117
FIGURE 47 - Keypad Test Screen	118
FIGURE 48 - Display Test Main Screen	119
FIGURE 49 - Bit Patterns Test Screen	121
FIGURE 51 - Serial Inputs / Outputs Test Screen	123
FIGURE 50 - Microboard -Com 5 Serial Data Port	124
FIGURE 52 - Digital Inputs / Outputs Test Screen	125
FIGURE 53 - Analog Inputs Test Screen	128

LIST OF TABLES

TABLE 1 - Boot-up LED Indicators	20
TABLE 2 - Addresses and Associated Data.....	21
TABLE 3 - Diagnostic Display Codes.....	36
TABLE 4 - Multiplexer Channels	39
TABLE 5 - Summary of Differences	43
TABLE 6 - Microboard.....	43
TABLE 7 - MUX Address.....	86
TABLE 8 - SI Metric Conversion	139

SECTION 1 - INTRODUCTION

This document explains the operation of the printed circuit boards and major components of the OptiView Control Center to a level that allows a Service Technician to troubleshoot and locate the source of a problem.

The overall system architecture is described and illustrated with block diagrams. This describes the general function of each component and provides the system interface and signal flow. The function of each component and signal flow between components must be understood before effective troubleshooting can commence.

The operation of each printed circuit board is described and illustrated with a block diagram that is a simplified representation of board circuitry. The expected voltage level at all inputs and outputs of each board for any operating condition is provided.

Included in this document are procedures that have to be performed at chiller commissioning or during service. They should not be performed by anyone other than a Service Technician. For example, calibration procedures have to be performed or verified at system commissioning or when a component is replaced. Certain Safety shutdowns require special reset procedures to be performed before the chiller can be restarted. Since the operating program supplied in each OptiView Control Center is universal to all applications, special setpoints, program jumpers and program switches are required to configure the chiller for local operating conditions.

A System Commissioning Checklist is provided as reference of items to be performed during chiller commissioning.

In addition to this document, several levels of supporting documentation are required while servicing the system. The *Operating Instructions (Form 160.72-01)* explains the operation of the OptiView Control Center Keypad, how to enter Setpoints and explains all the

messages displayed on the OptiView Control Center display. Unit wiring diagrams provide component interconnections within the Optiview Control Center and the connections between these components and the motor starter and chiller components.

When the chiller shuts down on a **SAFETY** or **CYCLING** shutdown or is being prevented from starting, a message is displayed providing the reason for the shutdown. This message, along with all the chiller operating conditions at the instant of the event are stored in the Microboard battery-backed memory. This history data can be displayed or printed using an optional printer. The *Operating Instructions (Form 160.72-01)* provides a detailed description of this message, including the conditions required to produce the message and conditions required to restart the chiller.

Diagnostic Routines allow service analysis of the following functions:

- Display
- Analog inputs
- Analog outputs
- Digital inputs
- Digital outputs
- Serial Data ports

Before beginning any troubleshooting, observe the shutdown message and retrieve the **HISTORY** data of that event. Refer to the Operations Manual for an explanation of the message. The conditions required to produce the message must be clearly understood before proceeding. (If this is not heeded, much time will be wasted). Armed with a knowledge of the overall system architecture and the function of each printed circuit board and signal flow provided by this manual, proceed with the appropriate wiring diagram to trace the problem through the system. Use the diagnostic routines where appropriate.

THIS PAGE INTENTIONALLY LEFT BLANK.

SECTION 2 - SYSTEM ARCHITECTURE

The OptiView Control Center performs the following functions:

- Controls chiller capacity to chill liquid to the chilled liquid temperature setpoint.
- Controls chiller solenoid valves, relays, actuators and motor contactors per the operating program.
- Displays chiller operating conditions, alarms, shutdown messages and history data.
- Accepts operator-programmed setpoints and controls the chiller accordingly.
- Allows manual control of chiller motor contactors and actuators.
- Monitors chiller operating conditions and shuts down chiller when Safety or Cycling thresholds are exceeded.
- Allows local manual start/stop and accepts start/stop commands from remote devices, via contact closures or serial communications.
- Allows setpoints to be changed from a remote location via 0-10VDC, 2-10VDC, 0-20mA, 4-20mA, contact closures or serial communications.
- Provides chiller operating data and status to remote devices via serial communications and contact closures.
- Allows real-time data and history data to be printed on an optional printer.
- Controls the compressor motor starter and contains a printed circuit board logic that supports Electro-Mechanical Starters.

The OptiView Control Center is a microprocessor based control system that receives analog, digital and serial data inputs and controls analog, digital and serial data outputs per instructions in the operating program. A panel mounted display and touch-sensitive keypad permit local operation.

System pressures are sensed by pressure transducers. The output of each transducer is a milliamp (mA) Signal that is analogous to the pressure input. System temperatures are sensed by RTD's. The output of each RTD is a milliamp (mA) Signal that is analogous to the temperature it is sensing. The typical output range of both is 4 to 20 milliamp (mA).

Digital Inputs are on/off inputs to the OptiView Control Center in the form of switch and relay contacts. These inputs are 115VAC when the contacts are closed and 0VAC when open. These include flow switches, local start/stop switch, remote cycling and high pressure safety device, etc.

Digital Outputs are on/off outputs from the OptiView Control Center in the form of relay contacts. The relay contacts typically switch 115VAC. The relay outputs include status/alarm, chiller solenoid valves, oil heater, oil pump starter, chilled and condenser water pump starters, etc.

Analog Outputs are 4 to 20 milliamp (mA) outputs. The outputs include compressor pre rotation vane, hot gas valve, and one or two interstage gas valves.

Serial Data is transmitted to and received from devices in RS-232, RS-485 and TX/RX (opto-couple) form.

The OptiView Control Center supports Electro-Mechanical Starters. All OptiView Control Centers contain the following standard components.

- Microboard
- 2 I/O (input/output) Boards
- Keypad
- Display
- 2 power supplies
- 3 Analog boards
- timers and relays

In addition to the standard components, the OptiView Control Center may contain a CM-2 Current module that provides certain control and interface functions for the Electro-Mechanical starter type applied.

If the OptiView Control Center communicates to the starter via Modbus it would not contain the CM-2 Module.

FIGURES 1 and 2 are the OptiView Control Center block diagrams of the two starter types on each block diagram, the standard components are shown, along with the printed circuit boards that support the applied starter type.

The microprocessor and all supporting logic circuits, along with the memory devices containing the operating program, reside on the **Microboard**. All chiller operating decisions are made here. It receives analog and digital inputs from the chiller and remote devices. The analog inputs are connected to the three Frick analog boards. The digital inputs are received via the two I/O boards, one is a YORK design the other is a Frick design. Under program control, the Microboard operates the relay outputs on the two I/O boards and the analog outputs on Frick analog board number one and Frick analog board number two.

The control center will be equipped with one of the following Microboards:

- 031-01730-000 – The program resides in a replaceable Flash Memory Card. The software version is C.MLM.01.xx.yzz. It is printed on a label adhered to the card.
- 031-02430-000 – The program resides in non-removable onboard memory. The software version is C.OPT.13.xx.yzz, and is viewable on the DIAGNOSTICS Screen in SERVICE access level. The Program can be upgraded by downloading a new program from a Program Card. Program Cards are shirt-pocket-size portable memory storage devices available from YORK. This board is backward compatible to OM chillers presently using the 031-01730-000 microboard.
- 031-02430-001 – This is an upgraded version of the 031-02430-000 microboard. The upgrade is necessary to operate with the Medium Voltage Solid State Starter, that serially communicate with the microboard using Modbus Protocol.

The upgrade includes a larger BRAM (U38) and an additional RS-484 port on COM2 serial port for Modbus communication. This board is backward compatible with OM chillers presently using the 031-01730-000 or 031-02430-000 microboards

Since the newer versions Microboard are backward compatible to earlier vintage OptiView Control Centers, earlier vintage chillers could be equipped with a later version Microboard due to service replacement.

The software versions (C.MLM.13.xx.yzz or C.OPT.13.xx.yzz) are alphanumeric codes that are interpreted as follows. Each time the controls section or language section is revised, the respective revision level increments.

- C – Commercial chiller
- MLM – Used on Microboard 031-01730-000
- OPT - Used on Microboard 031-02430-000/-001
- 13 – OM chiller
- xx - controls revision level (00, 01, etc)
- y – language package (0=English only, 1=NEMA, 2=CE, 3=NEMA/CE)
- zz – language package revision level (00, 01, etc)

The **I/O Board** acts as an input/output device for the Microboard. It conditions the digital input signals for the Microboard and contains relays that are controlled by the Microboard to control solenoids and motor contactors. The 115VAC digital inputs from switch and relay contacts are converted to logic level voltages by Opto-Couplers. The relays have +12VDC coils that are energized and de-energized by the Microboard. The contacts of these relays control the 115VAC system solenoids, relays and motor contactors.

A front panel-mounted **Keypad** allows Operator and Service Technician user interface. Membrane keys are used to display chiller and system parameters, enter setpoints and perform chiller and OptiView Control Center diagnostics. It also contains a **START-RUN-STOP/RESET** Switch that is used to locally start and stop the chiller and perform manual reset functions.

A front panel mounted liquid crystal **Display** allows graphic animated display of the chiller, chiller subsystems and system parameters. The chiller and working components of the chiller are displayed, along with chiller operating pressures and temperatures. The Keypad is used to select displays showing increasing levels of detail of chiller working components.

The two self contained **Power Supplies** supply the necessary DC voltages for all the components within the OptiView Control Center.

When the compressor motor is driven by an Electro-Mechanical Starter, the OptiView Control center is equipped with a **CM-2 Current Module**. This printed circuit board provides current overload and power fault protection for the compressor motor. Current Transformers, located in the compressor motor terminal box, along with rectifying and calibration circuitry, provide an analog voltage representing compressor motor current to the CM-2 Module. This signal is further conditioned and provided to the Microboard.

When the compressor motor is driven by a YORK Medium Voltage Solid State Starter the MVSSS serially communicates with the microboard using RS-484 Modbus Protocol.

Serial data interface to a building control system is through the optional E-Link Gateway. This printed circuit board requests data from the Microboard and makes it available to the control system network.

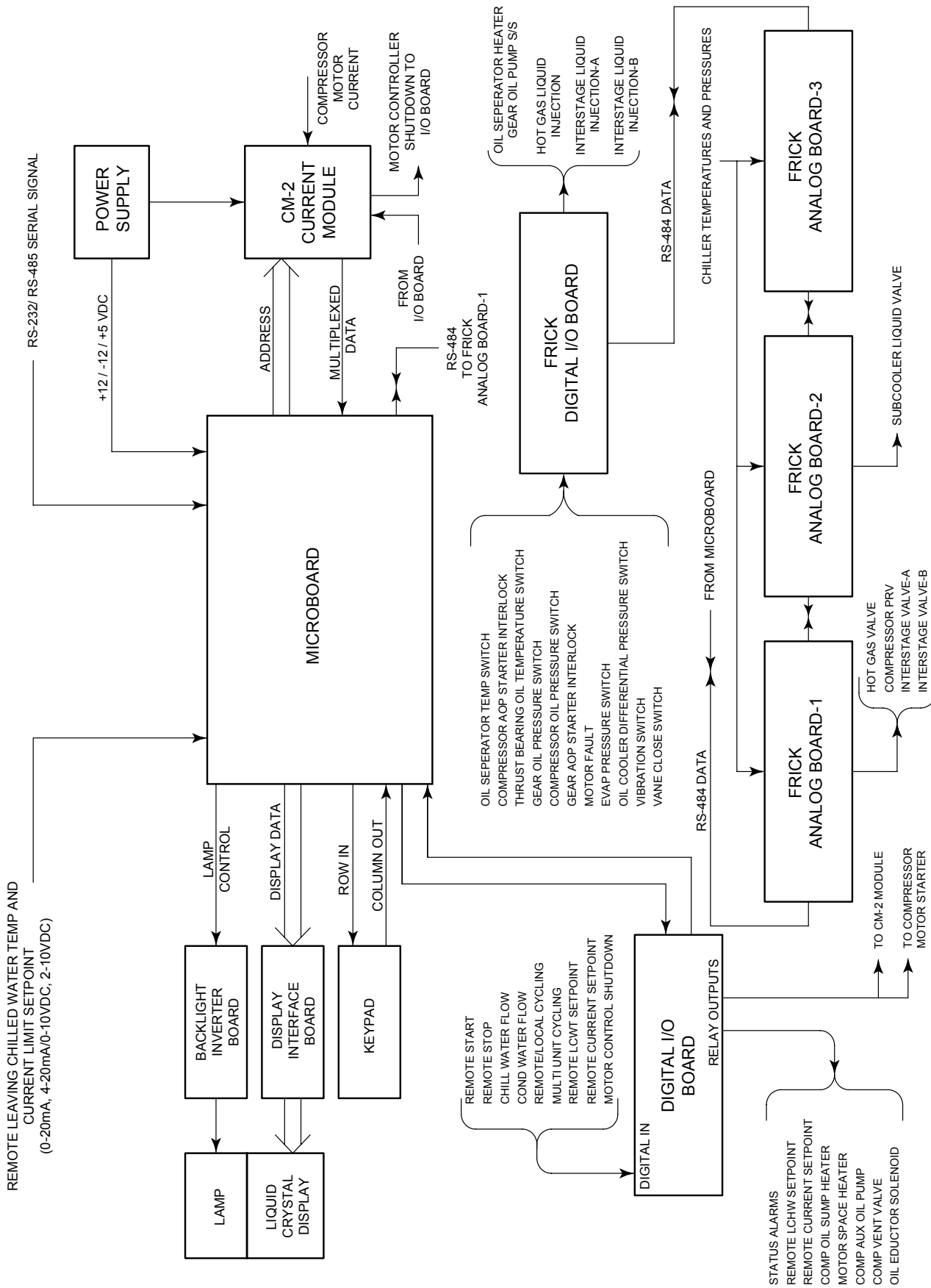
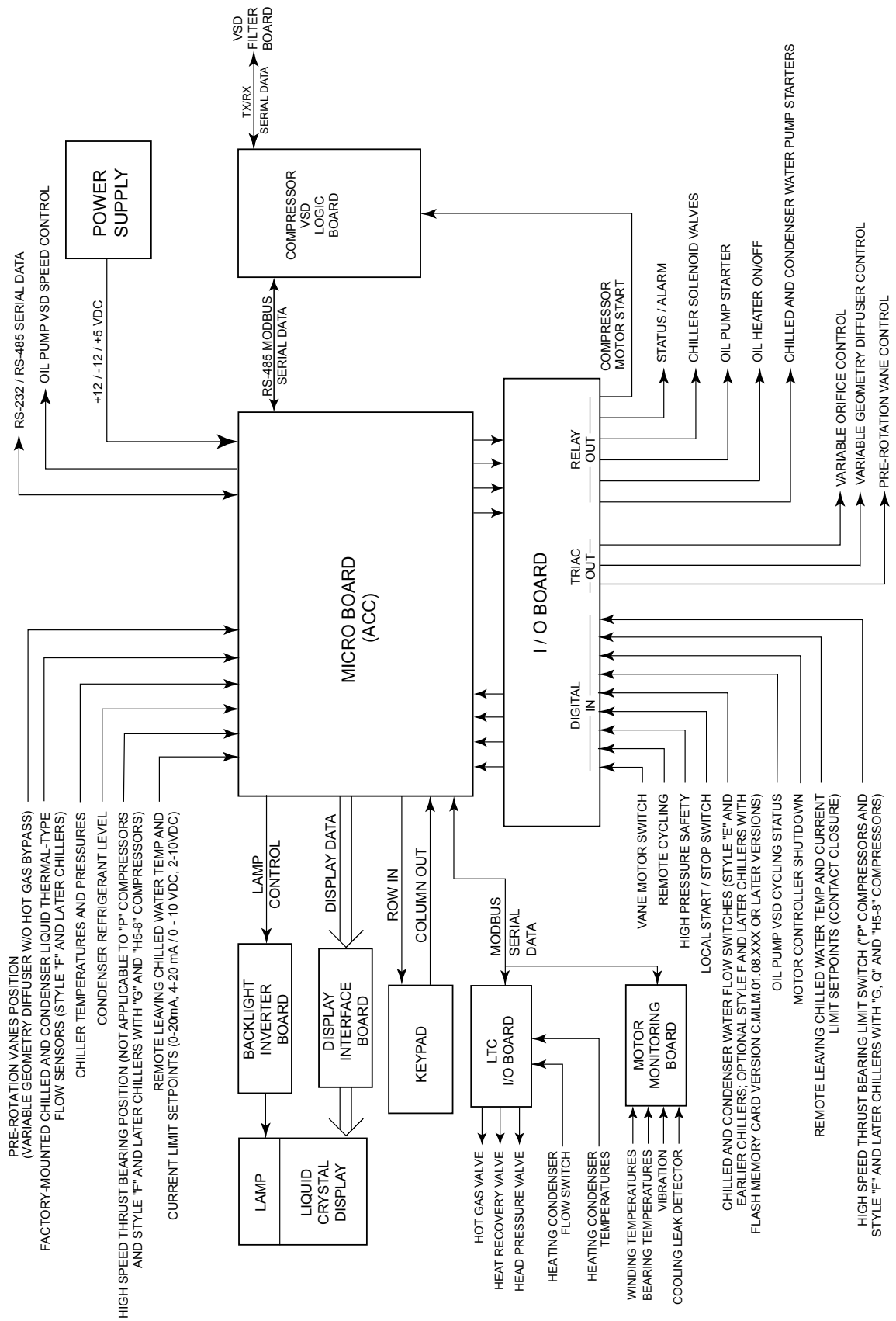
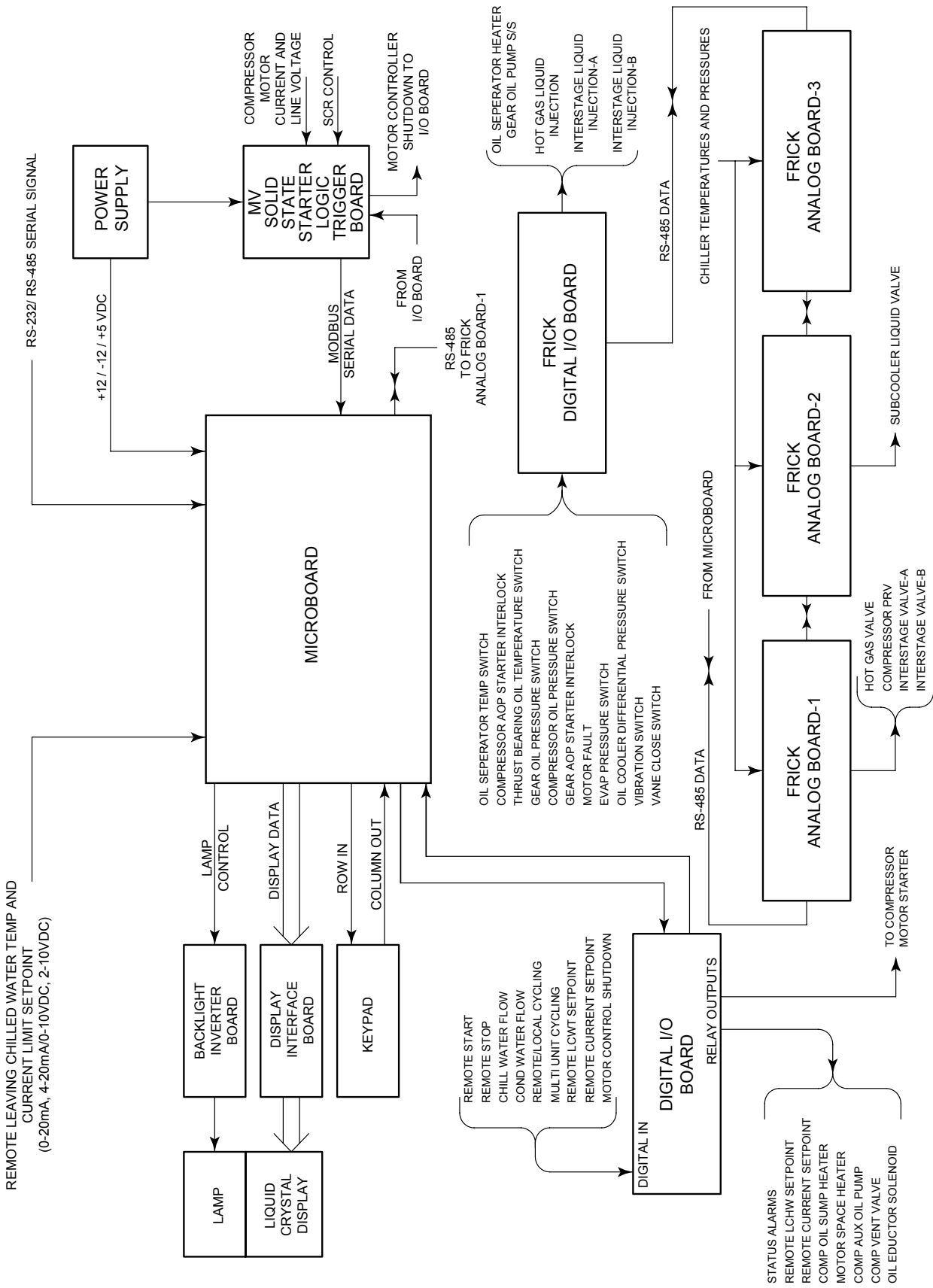

FIGURE 1 - OPTIVIEW CONTROL CENTER - COMPRESSOR MOTOR ELECTRO-MECHANICAL STARTER (EM)



LD09561e1

FIGURE 2 - OPTIVIEW CONTROL CENTER - COMPRESSOR MOTOR VARIABLE SPEED DRIVE (MODBUS SERIAL COMMUNICATIONS PROTOCOL)



LD09561f1a

FIGURE 3 - OPTIVIEW CONTROL CENTER - COMPRESSOR MOTOR MEDIUM VOLTAGE VARIABLE SPEED DRIVE

TIMING DIAGRAM – CHILLERS EQUIPPED WITH FIXED SPEED OIL PUMP (STYLE C)

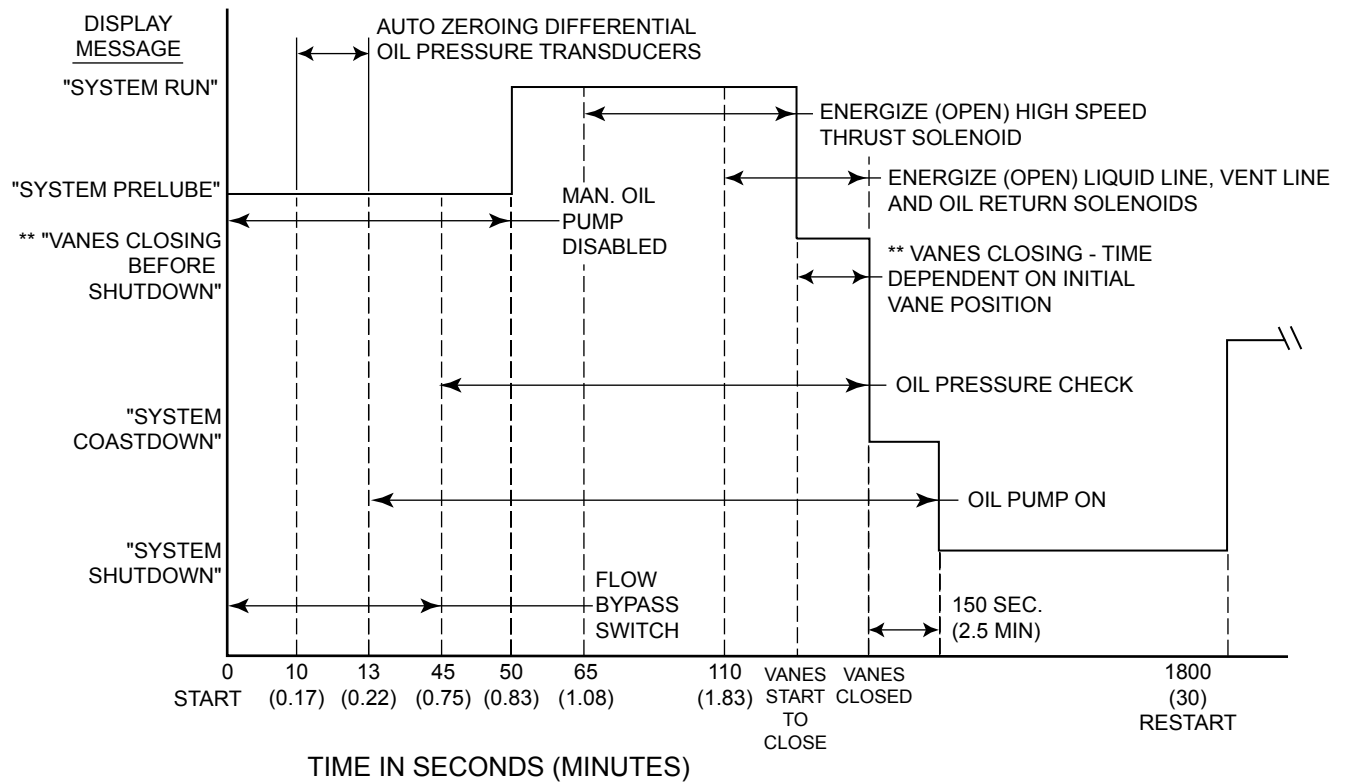

LD06501

FIGURE 4 - OPERATION SEQUENCE TIMING DIAGRAM (ELECTRO-MECHANICAL AND SOLID STATE STARTER APPLICATIONS)

THIS PAGE INTENTIONALLY LEFT BLANK.

SECTION 3 - MICROBOARD 031-01730-000

Microboard 031-01730-000 is supplied in new production chillers until January 2004.

The **Microboard** contains the operating software (Program), microprocessor (Micro), and supporting circuits for the Micro.

The **Program** is a set of instructions to control the chiller, the display and peripheral devices. It also contains the Safety and Cycling shutdown thresholds (non changeable) and display messages and screens. It is stored in a memory device called a **flash memory card**. This is a type of non-volatile memory that can be read from or written to, but requires the locations to be erased before they are written to. With the exception of a write/read sequence that occurs during the Boot-up process explained below, this device is used primarily as read-only in this application. A write protect switch is located on the left edge of the card as shown in *FIGURE 6*. It must be placed in the WRITE ENABLED position in order to allow successful Boot-up. The card is located in socket location U46 (Refer to *FIGURE 5*). It connects to the Board via an Elastomeric connector that is a silicon rubber strip embedded with silver conductors. The Card can be removed from its socket by using the thumb to press down on the socket's plastic tension spring. The card is installed by inserting it into the socket/holder and pressing on the surface of the Card until it snaps into place.

The Memory card is a replaceable component. The version of the Memory card is an alpha-numeric code that represents the application and revision level. The version is printed on a label adhered to the memory card's surface. The version code is as follows:

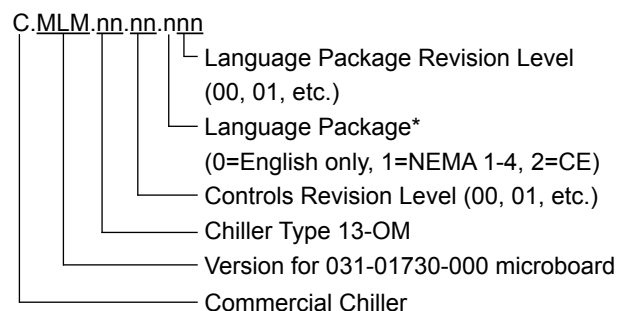

IMPORTANT! – Not all versions of Flash Memory Cards are compatible with revision “E” (and later) Microboards or all BIOS Eproms. If an incompatible version is used, the initialization (boot-up) process will not complete and the chiller will not run!

The **Micro** controls the chiller by reading and executing the Program instructions in a sequence determined by the Program. Under Program control, the Micro reads the Analog and Digital Inputs to determine the operating conditions and controls Digital Outputs based upon these inputs. These inputs are compared to stored thresholds to determine if a Safety or Cycling shutdown is required. If a threshold has been exceeded, a shutdown is performed and the appropriate message is retrieved from the Program and displayed on the Liquid Crystal Display. As operating conditions require, status messages are retrieved and displayed. The Keypad is read as Digital Inputs, when an operator presses a key to request a display, the Micro interprets the request, retrieves the display from the Program and displays it. The Program assembles data in the correct format for transmission through the Serial Data Ports to peripheral devices. The Program also instructs the Micro to respond to requests from peripheral devices for serial data transmissions.

The **Watchdog** circuit monitors the +5VDC supply from the external Power Supply to determine when a power failure is occurring. Just prior to the supply decreasing to a level where the Micro and supporting circuits can no longer operate, it applies a reset signal to the Micro. The Micro responds by de-energizing the run digital output through the FPGA, shutting down the chiller and retrieving the **Power Failure** message from the Program and sending it to the Display Controller for display. Similarly, when power is first applied after a power failure, it maintains the Micro in a reset state until the +5VDC has returned to a sufficient level. The Watchdog circuit also assures that all the Program instructions are being performed and that the Program has not latched-up, bypassing important safety thresholds. If the Program has latched-up, The Micro initiates a Safety shutdown and displays **WATCHDOG – SOFTWARE REBOOT** message.

The **BIOS EPROM** (basic input/output system erasable programmable read only memory) is a memory device that contains the bootstrap or power-up program. It is located in socket location U45. This EPROM is replaceable. The EPROM version is an alpha-numeric code that represents the application and revision level. The version is printed on a label adhered to the EPROM's surface. The version code is as follows:

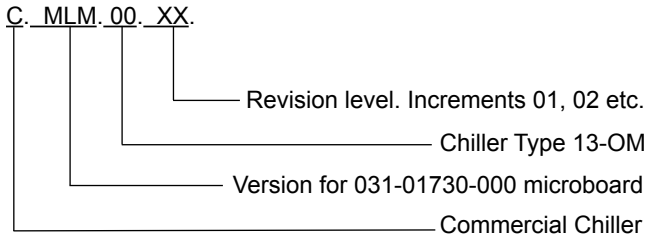

IMPORTANT! Eprom 031-01796-002 is not compatible with all versions of Flash Memory Cards. Refer to Service Replacement paragraphs in this section.

When power is applied to the OptiView Control Center following a power failure, the Micro executes the instructions in the BIOS EPROM program to initialize, configure and start operation of certain Microboard components before the main program (stored in the Flash Memory Card) is started. Depending upon the application, the Microboard could be equipped with an EPROM that has either 128K, 256K or 512K capacity. Microboard Program Jumper JP38 must be positioned according to the actual EPROM installed. There are 5 steps to the boot-up process. During the boot-up process, there is a visual indication as each step is performed, followed by a Pass/Fail status of the step. On the Microboard, a green LED (CR17 - Pass) flashes to indicate the step was successful. If a step is unsuccessful, a red LED (CR18 - Fail) flashes and the Boot-up process terminates. The execution and Pass/Fail status of steps 3 through 5 are displayed on a white Keypad Display Screen as they are performed. This white display screen also lists the BIOS EPROM Version. The steps of the Boot-up process are as follows. Also, below is listed the LED activity associated with each step.

BOOT-UP STEP AND DESCRIPTION

1. First initiate table complete

Registers in the Micro are configured to allow it to perform basic memory read/write functions.

2. FPGA configuration

The Field Programmable Gate Array (FPGA) is configured to process Digital Inputs and Outputs.

3. Mini-card signature test

A location in the Flash Memory Card that contains a code identifying the Manufacturer is compared to other locations that contain the manufacturer's name. If these values are the same, it is **pass**. If they are different, it is **fail**.

4. Mini-card checksum

The **Flash** Memory Card checksum is calculated and compared to the checksum value that is stored in the Card at the time the Card was initially programmed at the YORK Factory. If both values are the same, it is considered **pass**. If the calculated value is different than the stored value, it is considered **fail**.

5. BRAM quick test

Test data is written to and then read from several memory locations to verify BRAM operation.

LED Indicators

When power is applied to the OptiView Control Center, both the red (CR18 - Fail) and green (CR17 - Pass) LEDs simultaneously illuminate for 1 second, then the Boot-up process begins in the following sequence.

TABLE 1 - BOOT-UP LED INDICATORS

STEP	PASS	FAIL
1	Green on, Red off	Watchdog will initiate a re-boot.
2	Green flash once	Boot-up process halts. One red flash repeating
3	Green flash once	Boot-up process halts. Two red flashes repeating
4	Green flash once	Boot-up process halts. Three red flashes repeating
5	Green flash once	Boot-up process halts. Four red flashes repeating

When all steps have been completed, the LED's will then illuminate or extinguish, as long as power is applied, according to the settings of Microboard Program Switches 7 and 8 as follows:

Green (CR17)

Program SW 7 set to 50 Hz – extinguishes
60 Hz – illuminates

Red (CR18)

Program SW 8 set to Standard – illuminates
Enhanced – extinguishes

The **BRAM** (battery backed random access memory) is a memory device that contains a battery that preserves the data during power failures. It is a replaceable part. Refer to the *Renewal Parts (Form 160.72-RP1)*. It is located in socket location U52. The Micro stores the setpoints programmed by the Operator or Service Technician, History Data and other data that requires preservation, in this device. Also, the day of week, time of day and calendar date time-keeping are done here.

Program Jumpers/Program Switches

The Program Jumpers and Program Switches are used to alter the program operation or configure the Microboard hardware for specific operation. This allows the Program and Microboard to be universal for all standard applications. Refer to *SECTION 4 - MICROBOARD 031-02430-000 AND 031-02430-001* for the function of each jumper and switch. The position of some jumpers can be determined by the Service Technician to meet the desired operation. Others must be positioned according to the requirements of the size, type or style of components and thus are determined by the YORK Factory. Some jumpers are plastic sleeves with metal inserts that are inserted over 2-prong or 3-prong conductors. Others are wire bridges that are either cut or left in place. The Program Switches are miniature switches that are placed in either the ON or OFF position.

Keypad Interface

The Keypad is read via J18. The Keypad is a matrix of conductors arranged in rows and columns (Refer to *FIGURE 36* and *37*). There are 4 rows and 8 columns. When a key is pressed, the conductors are pressed together at that point, creating continuity between the row conductor and the column conductor. The keypad is read by applying a logic low to a row while leaving +5vdc pullup on all other rows. The micro then reads the 8 columns. If any column has a logic low on it, the key corresponding to that coordinate (row, column) is being pressed. The micro reads the entire keypad by repeating this routine beginning with row 1 and ending with row 4. The entire keypad is continually read while the control center is powered. Refer to *SECTION 9 - KEYPAD* of this manual for details of the Keypad.

CM-2 Board or Style A Solid State Starter Interface

The microboard retrieves certain operating parameters (via J10) from the compressor motor starter control board (CM-2 Current Board for Electromechanical starter or Style "A" Solid State Starter Logic Board). Refer to the appropriate section of this manual for detailed explanation of each board. Both boards contain an 8 channel multiplexer. The micro sequentially and continually reads channels 0 through 7. It reads each channel by applying a 3-bit binary address to the multiplexer. A 0-5vdc analog value is returned from each channel. The function of each is in the table below. The micro determines which board, and therefore which starter is present, by the value returned from channel 0. Since channels 0 through 6 are grounded, the CM-2 board returns a 0vdc value. The Solid State Starter Logic Board returns a value >0.41vdc to +5vdc. If the value is <0.4vdc, it indicates the starter is an Electro-mechanical (EM) starter and the micro then reads channel 7 to retrieve the peak motor current value. A value >0.4vdc indicates the starter is an "A" style Solid State Starter and the micro reads channels 1 through 7. In the Solid State Starter, channel 0 indicates the starter size (model) and voltmeter range (300Vac or 600Vac). Channel 1 is a hardware generated 100% FLA (prevents pre-rotation vanes from further opening) or 104% FLA (closes pre-rotation vanes until motor current is <102%) current limit override command that overrides normal Pro-rotation Vanes control. Channels 2 through 4 are analog voltages that represent phase A, B and C motor current. The highest phase is Channels 5 through 7 are analog voltages that represent phase A, B and C Line Voltage. The data for each channel is shown below:

TABLE 2 - ADDRESSES AND ASSOCIATED DATA

CM-2 BOARD		MOD "A" SOLID STATE STARTER LOGIC BOARD	
ADDRESS	DATA	ADDRESS	DATA
0 thru 6	Grid	0	starter model / voltmeter range
		1	current limit command
7	Peak Motor Current	2-4	phase C, B, A motor current
		5-7	phase A, B, C line voltage

Printer Interface

An optional Printer can be connected to COM1 RS-232 serial data port (J2). J2-4 is TX data to the printer. J2-2 is the DSR (Data Set Ready or busy) signal from the printer. Signal levels are standard RS-232. The microboard sends data to the printer at the selected baud rate until the printer buffer becomes full, whereupon the printer asserts its Busy signal. The microboard suspends data transmission until the printer can accept more data. Each printer must be setup/configured to operate properly with the microboard. The Baud, Data Bits, Parity and Stop Bits must be programmed on the Comms Screen. Other printer setup is performed on the PRINTER Screen. Refer to the *Operating Instructions (Form 160.72-01)* for details of available printers and printer setup instructions.

E-Link Gateway Interface

An optional E-Link gateway printed circuit board can be connected to the COM 4B RS-232 serial data port (J2). J2-7 is TX data to the E-Link gateway. J2-6 is RX data from the E-Link gateway. Signal levels are standard RS-232. The E-Link gateway polls system pressures, temperatures and status from the microboard. It holds it for retrieval by third-party devices.

Digital Inputs

The I/O Board converts the 115VAC inputs to logic level inputs for the microboard at J19. A 115VAC input to the I/O board is converted to a logic low (<1VDC). A 0VAC input to the I/O Board is converted to a logic high (>4VDC). Refer to *SECTION 5 - I/O BOARD* of this manual for details of the I/O Board.

Digital Outputs

The microboard controls 115VAC relays and solenoids via the I/O Board (via J19). The I/O Board contains +12VDC relays that isolate the microboard low voltage circuits from the 115VAC device coils. Solid state switching devices are used to control the relays. The microboard energizes the +12VDC relays by applying a ground to the coil input. They are de-energized by opening the ground path. The contacts of these relays switch 115VAC to system relays and solenoids. The outputs that control the chilled liquid pump and compressor motor starter have anti-chatter (anti-recycle) timers associated with them. The output that controls relay K0 is not allowed to change at a rate greater than once every 10 seconds. The output that controls relay K13 is not allowed to change at a rate greater than once every 20 seconds.

Analog Inputs

System pressures and temperatures are in the form of an analog 4 to 20 mA signal. They are inputs from the pressure and temperature transducers. Formulas and graphs are included to calculate the expected transducers output mA for a given pressure or temperature.

Serial Data Ports

The Microboard is equipped with 5 serial data ports (Refer to *FIGURE 9*). Each port is dedicated for a specific function as follows:

- A. COM1 (J2) – RS-232. Printer
- B. COM2 (J13) – RS-232. Not used
- C. COM3 (J12) – RS-485. Optional I/O.
- D. COM4 (4A-J11), (4B-J2) – This port is actually two ports. However, they cannot be used simultaneously. The position of program jumper JP27 determines which port can be used. COM4A – RS485 Not used. COM4B – RS-232 E-Link gateway.
- E. COM5 (J15) – Opto-coupled transmit/receive. VSD Adaptive Capacity Control Board or Style B Solid State Starter.

Each port is equipped with two LED's. A red TX LED illuminates as data is transmitted to or requested from another device. A green RX LED illuminates as data is received from another device. The RS-232 voltages are industry standard +5 to +25vdc and -5vdc to -25vdc logic levels. The RS-485 voltages are industry standard 0vdc and +1.5 to +5vdc logic levels. COM5 logic levels are 0vdc and +5vdc. A diagnostic test can be performed on each serial port to confirm proper operation. Refer to *SECTION 20 - DIAGNOSTICS AND TROUBLESHOOTING* of this manual.

The LED's and their functions are as follows:

- CR2 RX1 – COM1 serial port receive data.
- CR3 TX1 – COM1 serial port transmit data.
- CR12 TX4 – COM4 serial port transmit data.
- CR13 RX4 – COM4 serial port receive data.
- CR15 TX3 – COM3 serial port transmit data.
- CR14 RX3 – COM3 serial port receive data.
- CR11 RX2 – COM2 serial port receive data.
- CR16 TX2 – COM2 serial port transmit data.
- CR10 RX5 – COM5 serial port receive data.
- CR9 TX5 – COM5 serial port transmit data.

Display Interface

The graphic screens displayed on the liquid Crystal Display are created from the program downloaded from the Program Card and stored in the flash memory chip. The data to form these screens is output from J5. This data is in the form of red, green and blue drive signals applied to each of the 303,200 the display pixels arranged in a matrix of 640 columns x 480 rows. Each pixel consists of 3 windows; red, green and blue, through which a variable amount of light from the Display Backlight, is permitted to pass to the front of the display. The drive signals determine the amount of light permitted to pass through each window. The overall pixel color is a result of the gradient of red, green and blue light allowed to pass. The drive signal for each pixel is an 18 bit binary word; 6 for each of the 3 colors. The greater the binary value, the more light is permitted to pass. The pixels are driven sequentially from left to right, beginning with the top row. To coordinate the drive signals and assure the pixels in each row are driven from left to right and the columns are driven from top to bottom, the drive signals are accompanied by a clock and horizontal and vertical sync signals.

During the boot-up, the program in the BIOS eeprom reads wire jumpers PID0 through PID3 on the Display Interface Board to determine the manufacturer of the display. Each display manufacturer requires a slightly different control. The program in the BIOS eeprom configures the microboard for correct operation for the actual display installed.

Different display manufacturers require different supply and control voltages for their displays and backlights. Program Jumpers JP2 through JP5 and JP7 and JP8 must be configured to provide the required supply and control voltages to the display and backlight control. *SECTION 4 - MICROBOARD 031-02430-000 AND 031-02430-001* lists the required program jumper configuration for each display. Also, a label attached to the display mounting plate lists the required program jumper configuration for that display. The position of program jumper JP2 determines whether the supply voltage is +5VDC or +3.3VDC.

The microboard controls the Display Backlight via J6. The Display Backlight is the light source for the display. The Backlight Inverter Board provides a high voltage AC power source for the lamp. It converts low voltage DC via J6-1 (+12vdc or +5Vdc, depending on position of Program Jumper JP5) to high voltage AC (500 to 1500Vac). This high voltage AC is applied to the lamp to cause it to illuminate. The Backlight is

turned on and off with the BACKLIGHT ENABLE signal (J6-5). The position of Program Jumper JP4 determines whether this is a +12VDC or +5VDC signal. In some displays, the backlight turns on when this signal transitions from low to high; others turn on when it transitions from high to low. The position of Program Jumper JP3 determines the transition that will occur when the Microboard outputs the Backlight Enable signal. JP3 must be positioned according to the display manufacturer's requirement.

Under program control, the microboard controls the backlight brightness via the Lamp Dimmer circuit output at J6-7. In order to extend the life of the Backlight lamp, the brightness is driven to 50% after 10 minutes of Keypad inactivity. At this brightness level, the graphics are still visible. When Keypad activity is detected (a key is pressed), the lamp is driven back to full (100%) brightness. Some display manufacturers require a variable voltage to vary the brightness; others require a variable resistance. Program Jumpers JP7 and JP8 must be configured to enable the appropriate technique. The Lamp Dimmer is an integrated circuit that is the electrical equivalent of a 10K ohm potentiometer with 100 positions or steps (Refer to *FIGURE 15*). The Lamp Dimmer controls the position of the potentiometer. The lamp Dimmer varies the brightness of the backlight by applying a variable voltage (0-5.0VDC) or a variable resistance (0-10K ohms) to the Backlight Inverter Board. If Program Jumpers JP7 and JP8 are installed, the lamp Dimmer output is a variable voltage; if both are removed, the output is a variable resistance. The Lamp Dimmer outputs BRIGHTNESS CONTROL WIPER (J6-7) to the Backlight Inverter Board. If configured for variable voltage output, the voltage between J6-7 and J6-8 can be varied from 0VDC (100% brightness) to 5.0VDC (0% brightness). If configured for variable resistance, the resistance between J6-6 and J6-7 varies from 0 ohms (0% brightness) to 10K ohms (100% brightness).

Refer to Display SECTION 6, 7 and 8 of this manual for details of the display interface.

Remote Setpoints

Remote Leaving Chilled Liquid temperature and Current Limit setpoints can be input via the RS-232 E-Link gateway interface at J2 or directly to the Microboard at J22 (Refer to *FIGURE 10*). The inputs at J22 are configured with Program Jumpers JP23 and JP24 to accept these inputs in either 0-10VDC, 2-10VDC 0-20Ma or 4-20Ma form. Refer to Program Jumper configurations

and *SECTION 16 - REMOTE SETPOINTS* of this manual for details of the Remote Setpoints.

POWER SUPPLY

There are two power supplies

Power supply 1

The Microboard receives 3 supply voltages (Microboard J1) from the **Power Supply**; +12VDC, -12VDC, +5VDC and Ground. The -12VDC and +12VDC are used directly by various circuits. The +12VDC and +5VDC are input to **Voltage Regulators** to derive other regulated voltages. The +5VDC (fused by 5 Amp fuse F1 on rev "E" and later boards) is input to a +3.3VDC regulator. The output is a 3.3VDC regulated voltage. The +12VDC (fused by 5 Amp fuse F2 on rev "E" and later boards) is input to a 5VDC regulator. The output

of this regulator powers only the Analog circuits. This includes the MUX, A/D converter, CM-2 module, As depicted on the Microboard figure, these voltages can be monitored at Test Posts TP1 through TP6.

Power supply 2

The three Frick analog receive +12VDC, -12VDC, and +5VDC from the power supply. The +12DCV and -12DCV are used to power the pressure and temperature transducers. The +5DCV supports the board circuitry of both the Frick analog and the Frick digital I/O board.

SERVICE REPLACEMENT

Replacement part number 331-02430-601 is supplied as service replacement for microboard 031-01730-000.

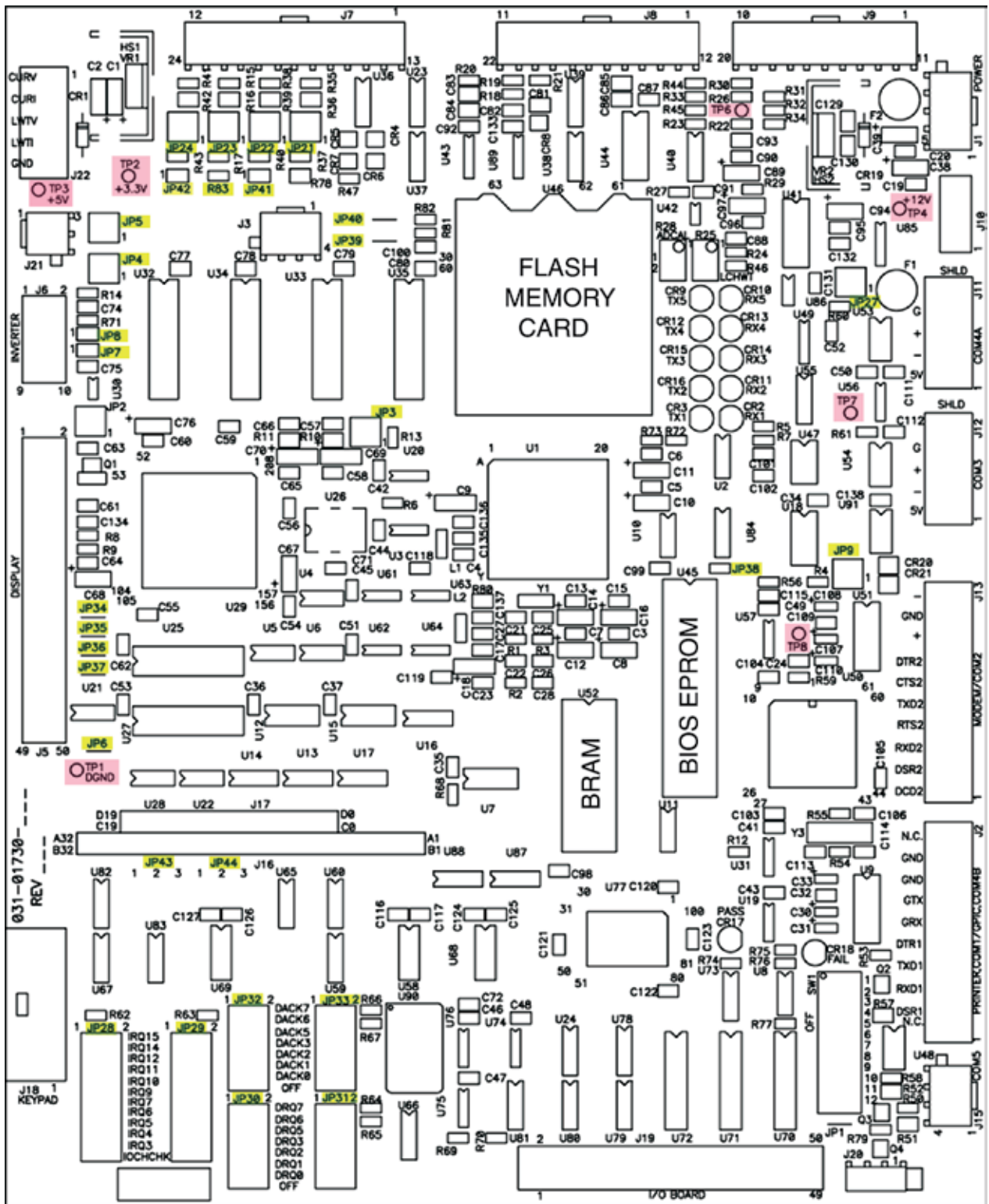

3

FIGURE 5 - MICROBOARD 031-01730-000

LD07776

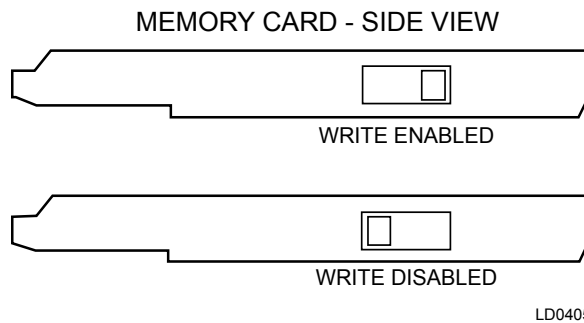
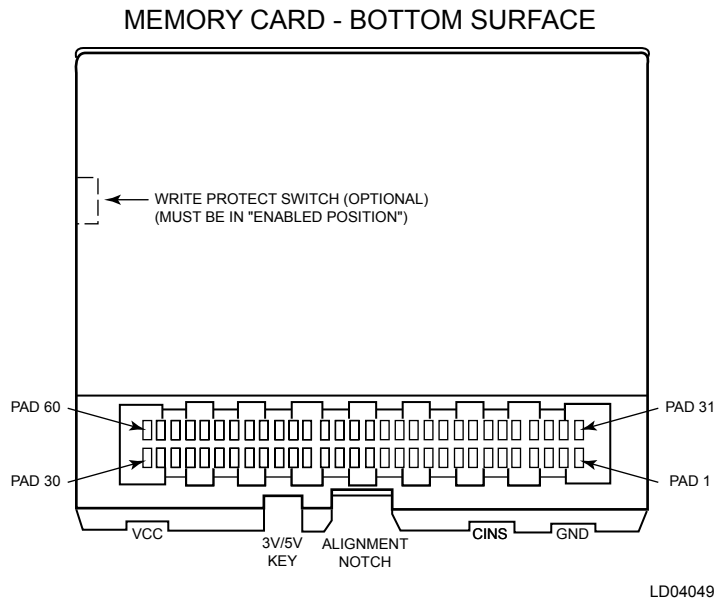
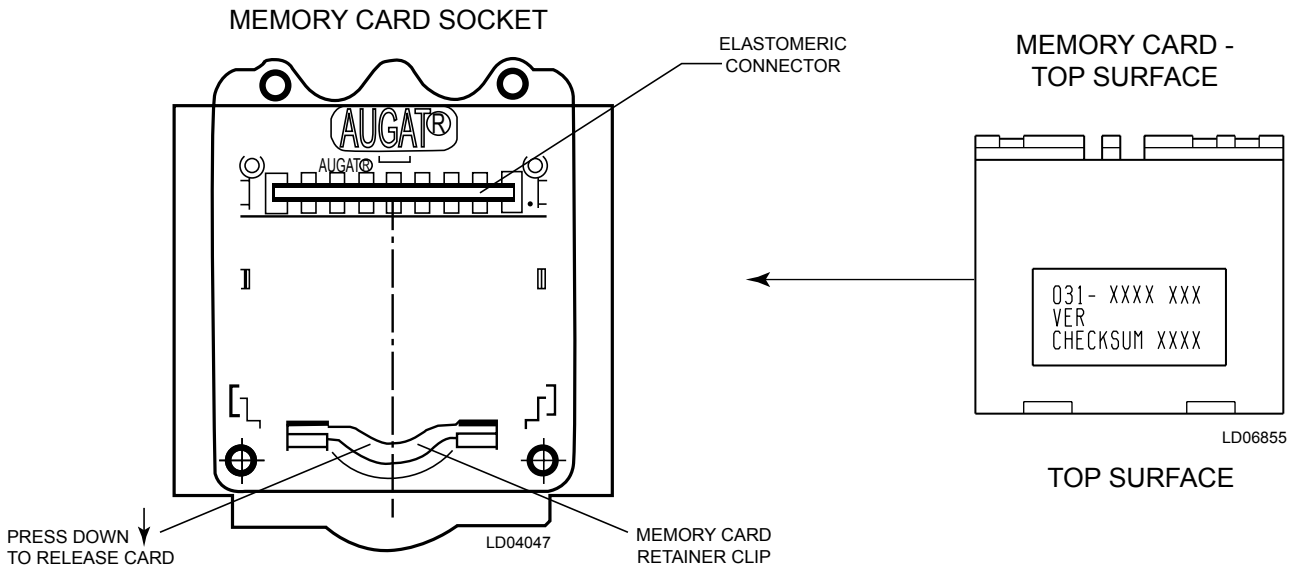
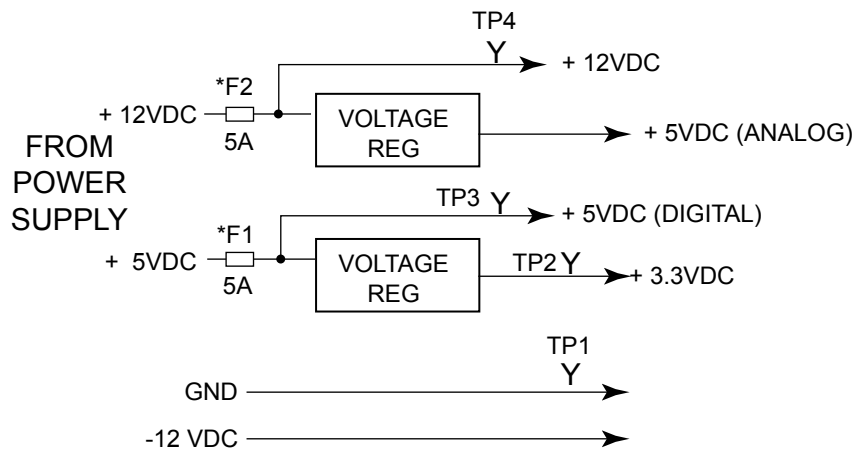

FIGURE 6 - FLASH MEMORY CARD



*REV "E" and later boards only.

LD09564

FIGURE 7 - MICROBOARD (031-01730-000) POWER SUPPLY TEST POINTS

PROGRAM JUMPERS

JP1 - Watchdog enable/disable. The position of this jumper, in conjunction with Program switch SW 1 position 12 enables or disables the program Watchdog protection.

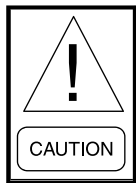

Never disable the watchdog protection. Severe compressor or chiller damage could result. The ability to disable the watchdog protection is provided for factory testing only!!!

IN - Watchdog protection enabled.

OUT -Permits Program switch SW1 position 12 to enable or disable the program.

Watchdog protection as follows:

Position 12 **ON** - Watchdog protection enabled

OFF - Watchdog protection disabled

JP2 - Display power and logic levels. Determines the power supply voltage applied to the display.

Pins 1-2: +5VDC SHARP LQ10D367/368 and LQ10D421 displays.

Pins 2-3: +3.3VDC NEC NL6448ACCC33-24 and LG Semicon LP104V2-W displays.

JP3 - Display backlight enable signal level polarity. Jumper must be positioned according to the voltage level required to turn on the Display Backlight.

Pins 1-2: 0VDC SHARP LQ10D421 Display.

Pins 2-3: +12VDC or +5VDC as determined by position of JP4. SHARP LQ10D367/368, NEC NL6448AC33-24 and LG Semicon LP104V2-W displays.

JP4 - Display backlight enable signal logic levels. Determines the logic levels of the Backlight enable signal.

Pins 1-2: +12VDC/0VDC SHARP LQ10D421 display.

Pins 2-3: +5VDC/0VDC SHARP LQ10D367/368 NEC NL6448AC33-24 and LG Semicon LP104V2-W displays.

JP5 - Display backlight power. Determines the power supply voltage applied to the Display Backlight Inverter Board.

Pins 1-2: +12VDC. SHARP LQ10D367/368 and LQ10D421, NEC NL6448AC33-24 and LG Semicon LP104V2-W displays.

Pins 2-3: +5VDC. Not Used

JP6 - Display memory type. Jumper must be positioned according to type of RAM used for display memory devices (U25 and U27).

IN - EDO: (extended data out) type. Jumper should be IN.

OUT - FPM: (fast page mode) type. Not Used

JP7, JP8 - Display brightness control technique. Determines whether the display brightness is controlled by a variable voltage or variable resistance.

IN: Variable voltage (0-5.0VDC). SHARP LQ10D367, LQ10D421 and LG Semicon LP104V2-W displays.

OUT: Variable resistance. NEC NL6448AC33-24 display.

JP9 - JP20 - Not Used

JP21 - Factory mounted thermal-type flow sensor – evaporator. Style “F” and later chillers only (applies to Flash Memory Card version C.MLM.01.07.xxx and later).

OUT: Not Used.

Pins 1-2: Not Used.

Pins 2-3: Style “F” and later chillers with factory mounted evaporator thermal-type flow sensor.

JP22 - Factory mounted thermal-type flow sensor – condenser. Style “F” and later chillers only (Applies to Flash Memory Card version C.MLM.01.07.xxx and later).

OUT: Not Used.

Pins 1-2: Not Used.

Pins 2-3: Style “F” and later chillers with factory mounted condenser thermal-type flow sensor.

JP23 - Remote Current Limit Setpoint (J22) type. Configures analog input for 0-10VDC, 2-10VDC, 0-20mA or 4-20mA.

OUT: Allows a 0-10VDC or 2-10VDC input on J22-1

Pins 1-2: Allows a 0-20mA or 4-20mA input on J22-2

Pins 2-3: Not Used

JP24 - Remote Leaving Chilled Liquid Temp Setpoint (J22) type. Configures analog input for 0-10VDC, 2-10VDC, 0-20mA or 4-20mA.

OUT: Allows a 0-10VDC or 2-10VDC input on J22-3

Pins 1-2: Allows a 0-20mA or 4-20mA input on J22-4

Pins 2-3: Not Used

JP25, JP26 - Not Used

JP27 - COM 4 serial communications port. Configures COM 4 port to be either RS-485 for Multi-Unit Communications (COM 4A) or RS-232 for GPIC board (COM4B).

Pins 1-2: Enables port 4A. Allows an RS-485 connection to Microboard J11 for Multi-Unit Communications.

Pins 2-3: Enables port 4B. Allows an RS-232 connection to Microboard J2 for the E-Link gateway communications.

JP28 - PC-104 Port interrupt assignment. Assigns selected PC-104 interrupt request to PIRQ7 on the microprocessor. Interrupt request selections are silk screened on the Microboard adjacent to the program jumper. Not used on OM chiller applications.

JP29 - PC-104 Port interrupt assignment. Assigns selected PC-104 interrupt request to PIRQ6 on the microprocessor. Interrupt request selections are silk screened on the Microboard adjacent to the program jumper. Future modem application.

JP30 - PC-104 Port DMA assignment. Assigns selected PC-104 DMA request to PIRQ0 on the microprocessor. DMA request selections are silk screened on the Microboard adjacent to the program jumper. Not used on OM Chiller applications.

JP31 - PC-104 Port DMA assignment. Assigns selected PC-104 DMA request to PIRQ1 on the microprocessor. DMA request selections are silk screened on the Microboard adjacent to the program jumper. Not used on OM Chiller applications.

JP32 - PC-104 Port DMA acknowledge assignment. Assigns selected PC-104 DMA acknowledge to PDACK0 on the microprocessor. DMA ac-

knowledge selections are silk screened on the Microboard adjacent to the program jumper. Not used on OM Chiller applications.

JP33 - PC-104 Port DMA acknowledge assignment. Assigns selected PC-104 DMA acknowledge to PDACK1 on the microprocessor. DMA acknowledge selections are silk screened on the Microboard adjacent to the program jumper. Not used on OM Chiller applications.

JP34 - Refrigerant type. Jumper must be positioned according to the refrigerant type installed in the chiller.

IN: R22

OUT: R134a

JP35 - Water/Brine application. Jumper must be positioned according to whether the chiller is cooling water or a brine solution.

IN: Water. Leaving chilled liquid temperature setpoint range 38°F (36°F if Smart Freeze is enabled) to 70°F.

OUT: Brine. Leaving chilled liquid temperature setpoint range 10°F to 70°F.

JP36 - Steam Turbine or Electric Motor drive - Determines the COASTDOWN duration (Oil Pump run duration after shutdown) and whether the MOTOR CONTROLLER-LOSS OF CURRENT Program check is performed while the chiller is running.

IN: 150 seconds. Electric motor drive applications.

OUT: 15 minutes. Steam Turbine applications. MOTOR CONTROLLER-LOSS OF CURRENT check is not performed.

JP37 - Compressor Motor starter type.

IN: Electro-Mechanical or Solid State Starter

OUT: Variable Speed Drive Program Jumper JP39 must be IN for this application.

JP38 - BIOS EPROM U45 size. Jumper must be positioned according to size of U45. Jumper is a 10 Ohm resistor that is soldered to board. It is not a shunt jumper.

IN: 256K

OUT: 64K or 128K. Should be OUT for OM chiller applications.

JP39 - Solid State Starter style.

Note: *On Variable Speed Drive applications, this jumper must be IN.*

IN: Mod "A" - Old style with Logic Board mounted in OptiView Control Center.

OUT: Mod "B" - New style with integrated Logic/Trigger Board mounted Starter cabinet.

JP40 - Not used

JP43, JP44 - Display Controller (U29) type (rev "E" and later boards only). Must be positioned according to the Display Controller type installed on Microboard. Configured at the time the board is manufactured and should not require field configuration.

Pins 1-2: Type 65548

Pins 2-3: Type 65550

JP41, JP42 - High Speed Thrust Bearing Proximity Probe type (Not applicable to "P" compressors and style "F" and later chillers with "G, Q" and "H5-8" compressors).

IN: Not Used

OUT: +24VDC Probe, part number 025-30961-000 or 025-35900-000.

JP43, JP44 - Display Controller (U29) type (rev "E" and later boards only). Must be positioned according to the Display Controller type installed on Microboard. Configured at the time the board is manufactured and should not require field configuration.

Pins 1-2: Type 65548

Pins 2-3: Type 65550

PROGRAM SWITCHES

SW1

- 1 - Not Used
- 2 - Oil Pump style - Configures Program operation for either Variable Speed Drive oil pump or fixed speed oil pump. Chillers equipped with the variable speed oil pump have a program controlled oil heater and a different complement of solenoid valves than chillers equipped with a fixed speed oil pump.

ON: (Style D/E/F) Variable Speed Oil Pump - Configures the Program to operate the Oil Pump Variable Speed Drive, the oil heater and the following Solenoid Valves: Oil Return and Liquid Line (J compressors only) connected in parallel to TB 1-6 1.

OFF: (Style C) Fixed Speed Oil Pump - Configures the Program to operate the fixed speed Oil Pump and the following Solenoid Valves: TB1-34 Liquid Line, TB1-61 Oil Return and Vent Line connected in parallel, TB1-62 High Speed Thrust.
- 3 - Prerun - Determines the duration of the SYSTEM PRELUBE period.

ON: Extended prerun. SYSTEM PRELUBE period is 180 seconds in duration. Oil Pump runs for 167 seconds.

OFF: Standard prerun. SYSTEM PRELUBE period is 50 seconds in duration. Oil Pump runs for 37 seconds.
- 4 - Diagnostics - Enables or disables software diagnostics.

ON: Enables software diagnostics. Disables normal chiller operation.

OFF: Disables software diagnostics. Enables normal chiller operation.
- 5 - Auto-restart - Determines the course of action required to restart the chiller, if a power failure occurs while the chiller is running.

ON: Chiller will automatically restart when power is restored.

OFF: Requires a manual reset after power is restored. The chiller will not start until the operator moves the keypad **START-RUN-STOP/RESET** rocker switch to the **STOP/RESET** position. If in **LOCAL** mode, the chiller can then be restarted by

initiating a local start. If in **REMOTE** mode, the chiller will restart upon receipt of a remote start signal .

- 6 - Anti-recycle - Enables or disables the anti-recycle timer.



The anti-recycle timer must NEVER be disabled unless it is absolutely necessary to do so during troubleshooting.

ON: Enables anti-recycle timer. Solid State Starter and Electro-mechanical starter applications - Chiller cannot be started at intervals shorter than once every 30 minutes. VSD applications (JP37 Out) – Chiller can be started at the completion of **SYSTEM COASTDOWN** at intervals shorter than once every 10 minutes up to 5 times. On the 5th shutdown, a 10 minute timer is started and restart is inhibited until the timer has elapsed.

OFF: Disables anti-recycle timer. Chiller can be started at the completion of **SYSTEM COASTDOWN**, regardless of how long the chiller had been running.

- 7 - Compressor Motor Variable Speed Drive - Motor/Power Line frequency application.

ON: 50 Hz

OFF: 60 Hz

- 8 - Chilled Water Pump operation - Determines Chilled Water Pump control contacts (I/O Board TB2-44/45) operation when chiller shuts down on various **CYCLING** shutdowns.

ON: Enhanced operation. Contacts open at completion of **System Coastdown** after all shutdowns except when it shuts down on **LEAVING CHILLED LIQUID - LOW TEMPERATURE, MULTIUNIT CYCLING - CONTACTS OPEN AND SYSTEM CYCLING - CONTACTS OPEN.**

OFF: Standard operation. Contacts open at completion of **System Coastdown** after all shutdowns except when chiller shuts down on **LEAVING CHILLED LIQUID - LOW TEMPERATURE.** On Low Water temp shutdowns, they remain closed, causing the pump to continue to run while the chiller is shutdown.

- 9 - Not Used

- 10 - Not Used

- 11 - Not Used

- 12 - Watchdog Protection -Used in conjunction with Program Jumper JP1 (see above) to enable/disable the program watchdog protection. With JP1 **IN**, this switch setting has no effect. With JP1 **OUT**, this switch setting determines whether the watchdog protection is enabled or disabled.

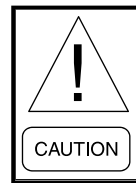

***NEVER** disable the watchdog protection! Severe compressor or chiller damage could result. The ability to disable the watchdog protection is provided for YORK Factory testing only.*

ON: Watchdog protection enabled.

OFF: Watchdog protection disabled.

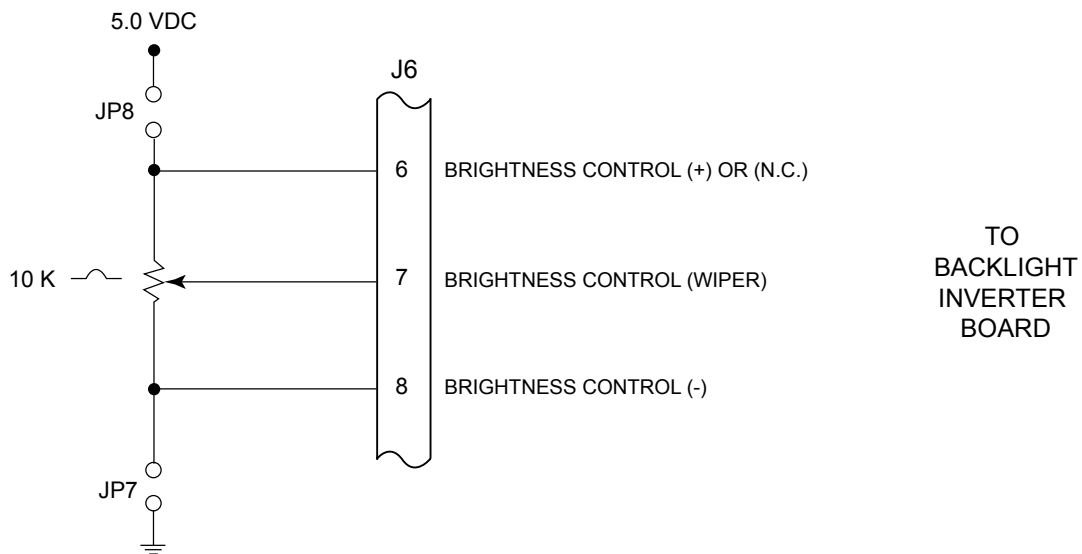

LD04054

NOTES:

1. J6-6 not connected (N.C.) to Backlight Inverter Board when display is manufactured by Sharp or NEC.
2. The position of Program Jumpers JP7 and JP8 determine the output at J6-7; In = Variable Voltage; Out = Variable Resistance. Refer to Program Jumper Listing for applications.
3. Potentiometer is actually an integrated circuit that is the electrical equivalent of a 10K potentiometer.

FIGURE 8 - MICROBOARD LAMP DIMMER CIRCUIT

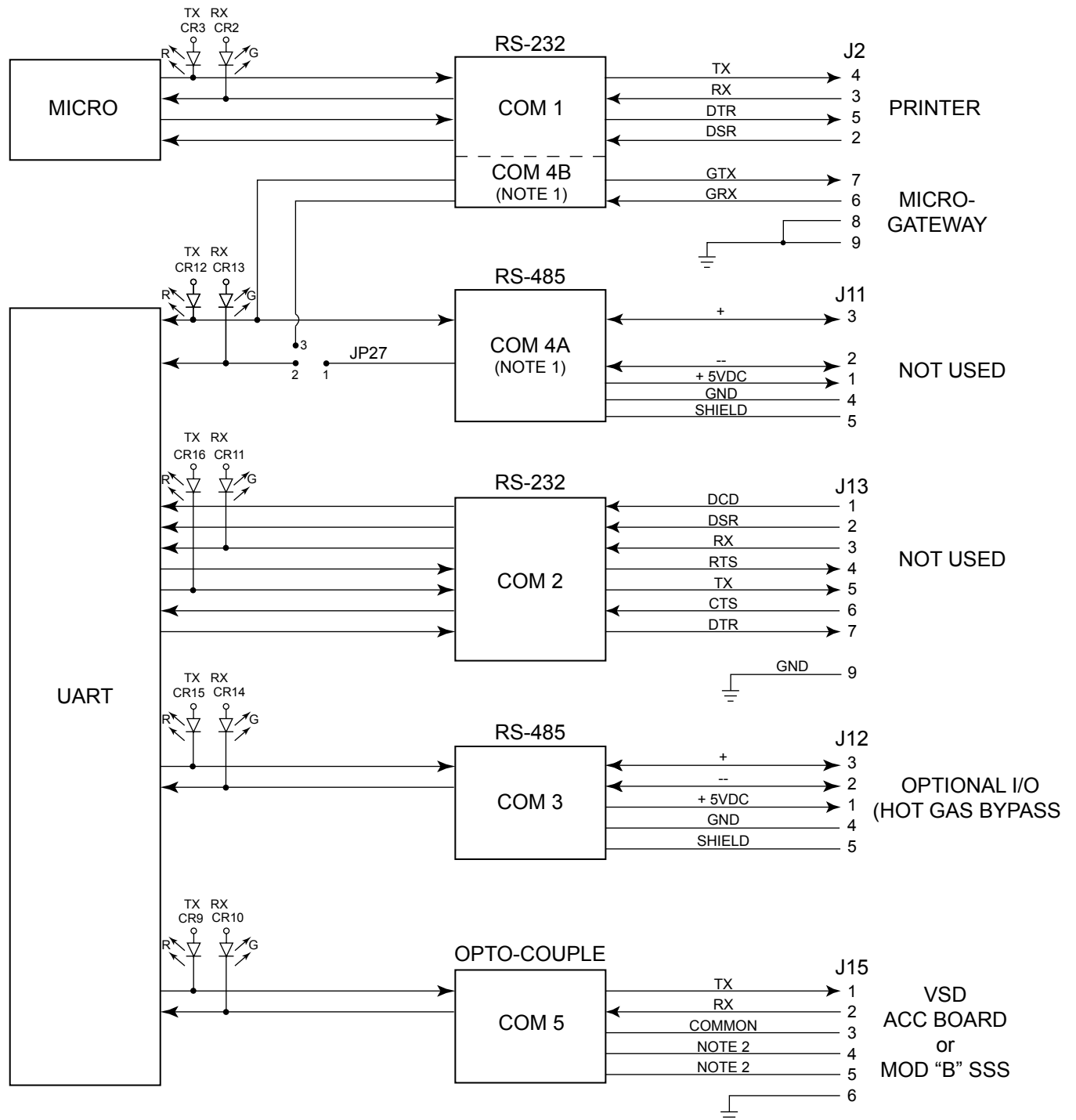

NOTES:

1. Microboard Program Jumper JP27 determines whether COM 4A or 4B can be used. 1 and 2 - 4A, 2 and 3, 4B.
2. J15-4 Loop-Around Test IN. J15-5 Loop-Around Test OUT.

LD07778

FIGURE 9 - MICROBOARD SERIAL DATA COMMUNICATIONS PORTS

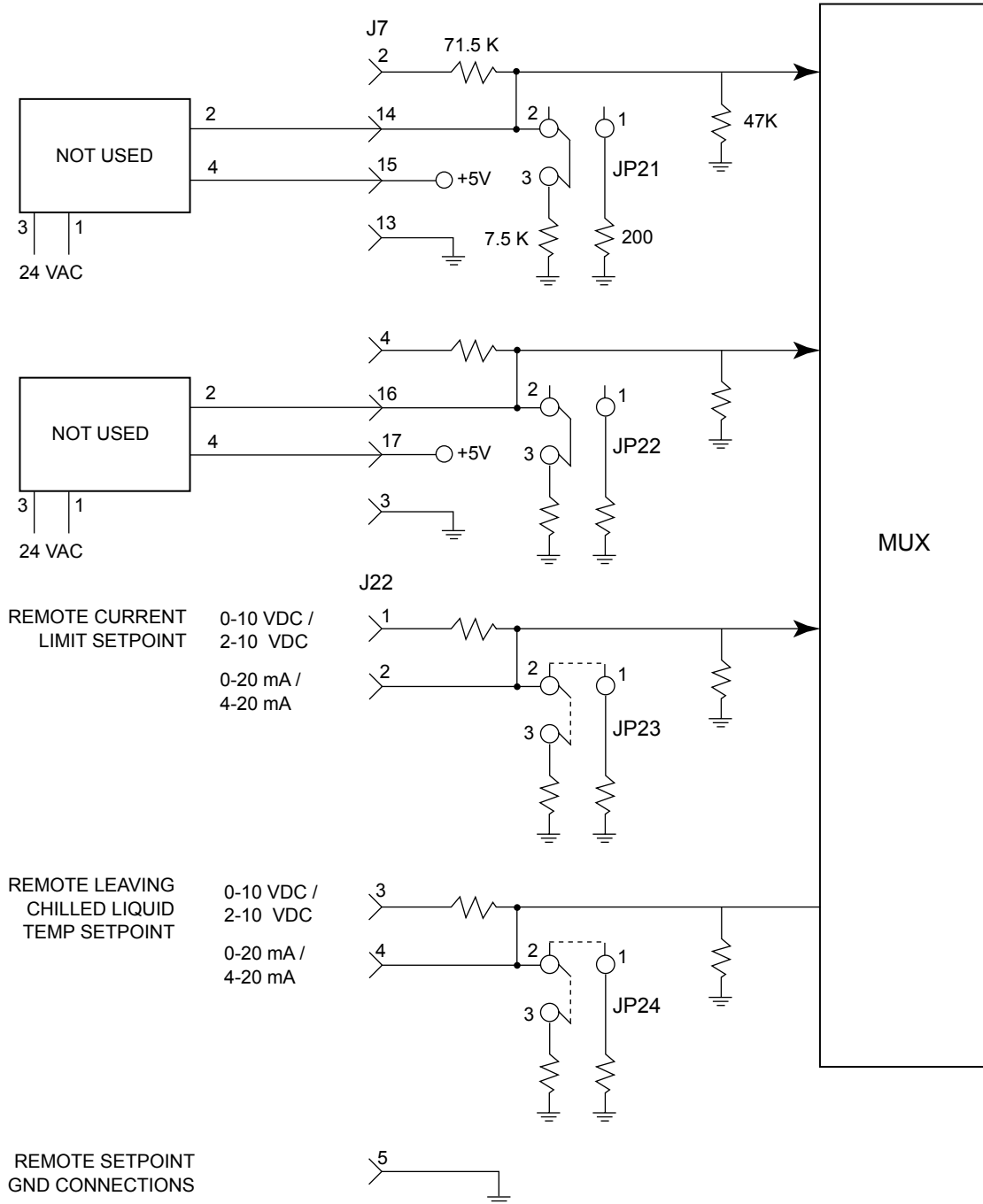

LD09565

NOTE:

1. Program Jumpers JP23 – JP24 must be positioned on pins 1-2 or 3-4 according to input signal type.
2. Applies to Flash Memory Card version C.MLM.01.07.xxx and later. Program Jumpers JP21 and JP22 must be on pins 2-3 on style F and later chillers equipped with factory-mounted thermal-type flow sensors.

FIGURE 10 - CONFIGURABLE ANALOG AND REMOTE SETPOINT INPUTS

SECTION 4 - MICROBOARD 031-02430-000 AND 031-02430-001

Microboard 031-02430-000 is supplied in new production OM chillers. Although this board uses a different microprocessor and supporting components, chiller control and operator interface are the same as the previous 031-01730-000 Microboard. It uses the same mounting hole pattern and has the same interface connectors as the previous board, making it backward compatible to all previous OM OptiView Control Centers equipped with the 031-01730-000 Microboard.

New production OM chillers will be supplied with microboard 03102430-001. This board is an upgraded version of the 031-02430-000 microboard. Its physical dimensions, mounting and connections are the same as the 031-02430-000 microboard. It is backward compatible to existing OM chillers using the 031-01730-000 or 031-02430-000 microboards and is supplied as service replacement for these boards in kit 331-02430-601. The upgrade includes a larger BRAM (U38) and an additional RS-485 port on COM2 serial port (J13) for Modbus serial communications protocol. The details of the differences between the -000 board and -001 board are described in the respective areas of this section. These upgrades are necessary for the following application that require RS-485 Modbus communications to the microboard:

- Medium Voltage Solid State Starter (MV SSS).

The board is supplied with +12VDC (J1-3), -12VDC (J1-4), +5VDC (J1-1) and ground (J1-2) from the Power Supply (Refer to *FIGURE 14*). The -12VDC is not used. The +5vdc (fused by F1) can be monitored at TP3. It is applied to a +3.3VDC regulator, +2.5VDC regulator and used directly by the microboard circuits as the Vcc voltage. The outputs of these regulators are applied to microboard circuits and can be monitored at TP2 and TP5 respectively. The +12vdc (fused by F2) can be monitored at TP4. It is applied to a +5vdc regulator and used directly by microboard circuits. The output of the regulator is the +5VDC (analog) supply that powers all analog circuits and is the source voltage for all transducers and transmitters. It can be monitored at TP10 as a 2.5VDC value created by 1K Ohm resistors voltage divider circuit as shown.

Test Points (Refer to FIGURE 14)

The power supply voltages can be measured at following test points:

TP1 Gnd
 TP2 +3.3VDC
 TP3 +5VDC
 TP4 +12VDC
 TP5 +2.5VDC
 TP10 +2.5VDC

Boot-up Program

The BIOS (Basic Input Output System) Eprom (U37) contains the boot-up program. The YORK Part Number is 031-02429-001 and is used in both the 031-02430-000 and 031-02430-001 microboards. It is available from the Baltimore Parts Distribution Center as a replacement part. The version is an alphanumeric code that identifies the application and the program revision level. The part number and version are printed on a label adhered to the surface of the Eprom. It is also displayed on the DIAGNOSTICS Screen in Service Access Level.

The version is as follows:

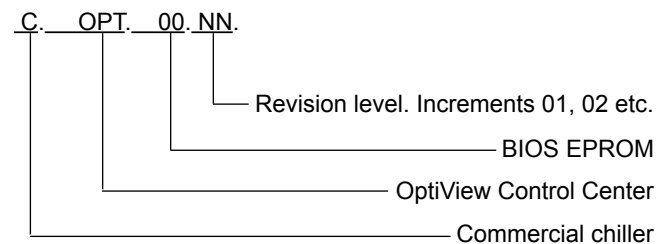

When power is first applied to the OptiView Control Center, a white screen is displayed while the boot-up is performed. During the boot-up, the program in the BIOS Eprom configures the microprocessor and related components and performs testing of certain components to assure those components are operational.

The sequence of events in the boot-up process are listed in the table on next page. The progress and pass/fail status of each step is displayed on the microboard 7-segment LED Display (U22). Due to the speed at which the boot-up proceeds, not all steps will be visible during the process. Not all pass/fail status is displayed on the white screen.

TABLE 3 - DIAGNOSTIC DISPLAY CODES

TEST	PASS CODE	FAIL ACTION	DISPLAY ON WHITE SCREEN
First init table complete	00	watchdog will cause reboot	No
SDRAM regs. Configured	01	watchdog will cause reboot	No
Switch to Protected Mode	02	watchdog will cause reboot	No
Jump to 32-bit code	03	watchdog will cause reboot	No
Low memory test start	04	watchdog will cause reboot	No
Low memory test complete	P1	"F1" on display and halt	No
Full memory test complete	P2	"F2" on display and halt	No
FPGA configuration	05	"P2" will remain on LED display	No
Display Cont. configured	06	"05" will remain on LED display	No
Flash Checksum Test	P3	"F3" will remain on LED display	Yes
BRAM test	P4	"F4" will remain on LED display	Yes
Flash Query Test	"passed"	"failed" and halt	Yes
Flash checksum	"passed"	"failed",halt and display code = F3	Yes
BRAM Test	"passed"	"failed" and halt	Yes
MISCELLANEOUS CODES			
LED DISPLAY CODE		DESCRIPTION	
FF		FPGA Configuration Failed, trying again	
CH		Flash Checksum Test in progress	
AP		Application setup in progress	
CRITICAL CODES			
LED DISPLAY CODE		DESCRIPTION	
Ni		NMI handler invoked (should never occur)	
[]		GPF has occurred (should never occur)	

Chiller Operating Program

The Chiller Operating Program is a set of instructions to control the chiller. It contains the Safety and Cycling shutdown thresholds (non-changeable) and display screen messages and graphics.

The chiller operating program is stored in a non-removable Flash Memory chip (U35) that is soldered to the Microboard. New chillers are supplied programmed with the latest program available at the time of manufacture. The program version that is currently residing in the Microboard Flash Memory chip is displayed on the DIAGNOSTICS Screen in Service Access Level.

The on-board program can be upgraded by downloading the latest version from a Program Card using the procedure in the Service Replacement section of this manual.

Program Card

The on-board program can be upgraded by downloading the latest program version from a Program Card. This is a 2 1/8 x 3 3/8 x 1/8 inch plastic card weighing 1.1oz (Refer to *FIGURE 13*). It is a portable memory storage device that is programmed with the chiller operating program. The Program Card part number for OM chillers is 031-02474-001 and is available from the Baltimore Parts Distribution Center (PDC). There is a Program Card for each chiller type (YT, OM, YS, YR, YD, etc) and each has a unique part number. A label affixed to the Program Card contains the part number and version. The version is an alpha-numeric code that identifies the chiller model applicability, language package, language package revision level and chiller operating program revision level.

The Program Card is applicable to both NEMA and CE applications. The Program Card for OM chillers has English, Simplified and Traditional Chinese, French, Portuguese, Spanish, Italian, German and Hungarian languages.

The program version that is currently residing in the Microboard Flash memory chip is displayed as the CONTROLS Software Version on the DIAGNOSTICS Screen in Service Access Level.

The Program Card obtained from the PDC is programmed with the latest version of the chiller operating program. Program Cards can be reprogrammed.

A Program Card for a particular chiller type can be used to re-program other chillers of the same type. For example, it is not necessary to have more than one OM Program Card. A single OM card can be carried to different locations to re-program other OM OptiView Control Centers.

A Write Protect Switch on the edge of the Program Card prevents inadvertent writing to the Card during program downloading.

Handling precautions for the Program Card include:

- Do not allow dirt to enter connector
- Carry in protective sleeve
- Storage temperature range is -20 to 65°C (-4 to 149°F)

A label adhered to the Program Card contains the version and YORK Part Number. The version is an alphanumeric code that identifies the chiller model applicability, language package, language revision level and chiller control revision level. The version is as follows:

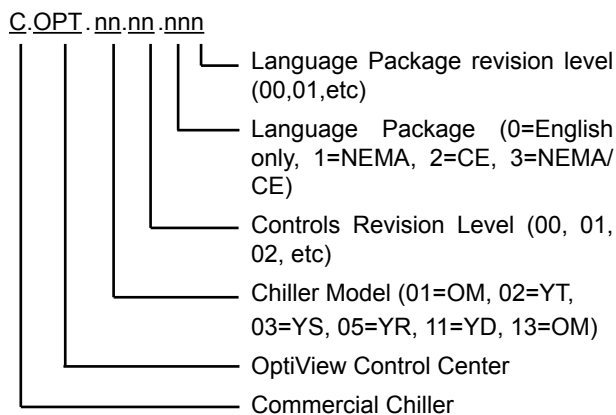

The Program card is inserted into connector U33 to download a program. Refer to instructions under Service Replacement below.

Program Download Connector U33

A Program Card is inserted into connector U33 to download a program. A protective cover prevents dirt from entering this connector. **IMPORTANT!** The protective cover must be in place at all times when not performing a program download. If dirt accumulates inside this connector, re-programming will not be successful.

Parallel Port Connector

Parallel port connector J4 is for future use. It is presently not supported.

BRAM (U38)

The BRAM (battery backed random access memory) memory device contains a battery that preserves the stored data during power failures. All of the programmed Setpoints, Sales Order Data, History Data, time of day and calendar data is stored here. The YORK Part Number is printed on a label adhered to the surface of the BRAM. It is available from the Baltimore Parts Distribution Center as a replacement part.

The part number of the BRAM (U38) in the 031-02430-000 board is 031-02431-000 and its size is 32KB. It is installed in a 28-pin socket. Program Jumper JP14 is a non-removable (soldered) wire jumper that connects DC power to the appropriate pin on the BRAM for 32KB operation.

The part number of the BRAM (U52) in the 031-02430-001 board is 031-02565-000 and its size is 128KB. It is installed in a 32-pin socket. Program Jumper JP14 is a removable 2-pin shunt type jumper. The 128KB BRAM requires the shunt be NOT INSTALLED and the board is supplied in this configuration. If the shunt is installed on JP14, it would apply DC power to an incorrect pin on the 128KB BRAM and the board would not function. The 128KB BRAM is required for MV SSS, MV VSD, and those VSD that communicate with the microboard using Modbus serial communications protocol.

The 031-02430-001 board with 128KB BRAM requires software that has "BRAM size detect" capability. If it does not have this capability, the board will not function. OM chiller software version C.OPT.01.15.xxx (and later) has this capability and is required.

When replacing a 031-02430-000 microboard with a 031-02430-001 microboard in applications other than MV SSS, MV VSD and VSD Modbus, the smaller BRAM from the 031-02430-000 board can be transferred to the 031-02430-001 microboard. See BRAM transfer exception in Microboard Service Replacement later in this section.

Watchdog Circuit

The Watchdog circuit performs two functions as follows:

- Power failure detection
- Program latch-up detection/prevention

The Watchdog circuit monitors the +5VDC from the power supply and the +3.3VDC from the onboard regulator to determine when a power failure is occurring. If the +5VDC decreases to the threshold of (+4.75VDC to 4.5VDC) or the +3.3vdc decreases to the threshold of (3.04 to 2.8VDC), a reset is issued to the microprocessor and the chiller shuts down. When power is restored, the white screen is displayed and the boot-up is performed as described above. When the graphic screen is displayed, the message CONTROL PANEL – POWER FAILURE is displayed.

The Watchdog Circuit also assures that the entire program is being executed and that the program has not latched-up, bypassing important safety checks. The Watchdog circuit is a timer that times-out if not given a reset pulse within its time-out period (1 - 2.25 seconds). To prevent a time-out, the microprocessor sends a reset pulse to the Watchdog circuit every time the complete program has been executed. Since it takes less than 1 second to perform the entire program, the Watchdog circuit doesn't time-out under normal operation. However, if the entire program is not executed or something prevents the microprocessor from sending the reset pulse as described below, the Watchdog circuit times-out and sends a reset to the microprocessor, initiating a re-boot. If running, the chiller shuts down. The display momentarily blanks and white screen is displayed while the boot-up program executes as described above. When the graphic screen is displayed, either of two messages is displayed depending on the type of Watchdog shutdown as explained below.

There are two different watchdog initiated shutdowns; a HARDWARE watchdog initiated shutdown and a SOFTWARE watchdog initiated shutdown.

In the HARDWARE watchdog initiated shutdown, a program problem, on-board noise or hardware problem could prevent the watchdog time-out. If this occurs, a re-boot is initiated and when the graphic screen is displayed, CONTROL PANEL – POWER FAILURE is displayed.

In the SOFTWARE watchdog initiated shutdown, the program intentionally initiates the reboot because it has detected program interruption. After the re-boot, WATCHDOG – SOFTWARE REBOOT is displayed on the graphic screen.

Program Jumpers/Program Switches

The Program Jumpers and Program Switches are used to alter the program operation or configure the Microboard hardware for specific operation. This allows the Program and Microboard to be universal for all standard applications. The position of some jumpers can be determined by the Service Technician to meet the desired operation. Others must be positioned according to the requirements of the size, type or style of components and thus are determined by the YORK Factory. The jumpers are plastic sleeves with metal inserts that are inserted over 2-prong or 3-prong conductors. The Program Switches are miniature switches that are placed in either the ON or OFF position.

Keypad Interface

The Keypad is read via J18. The Keypad is a matrix of conductors arranged in rows and columns (Refer to *FIGURE 36* and *37*). There are 4 rows and 8 columns. When a key is pressed, the conductors are pressed together at that point, creating continuity between the row conductor and the column conductor. The keypad is read by applying a logic low to a row while leaving +5vdc pullup on all other rows. The micro then reads the 8 columns. If any column has a logic low on it, the key corresponding to that coordinate (row, column) is being pressed. The micro reads the entire keypad by repeating this routine beginning with row 1 and ending with row 4. The entire keypad is continually read while the control center is powered. Refer to *SECTION 9 - KEYPAD* of this manual for details of the Keypad.

CM-2 Board or Style A Solid State Starter Interface

The microboard retrieves certain operating parameters (via J10) from the compressor motor starter control board. CM-2 for Electro-Mechanical starter (EM). Refer to the appropriate section of this manual for detailed explanation of the board. The board contains an 8 channel multiplexer. The micro sequentially and continually reads channels 0 through 7. It reads each channel by applying a 3-bit binary address to the multiplexer. A 0-5VDC analog value is returned from each channel. The function of each is in the table below. The micro determines the presents of the CM-2 board by the value returned from channel 0. Since channels 0 through 6 are grounded, the CM-2 boards returns a 0VDC value. A value less than 0.4VDC, indicates the starter is an Electro-Mechanical (EM) starter and then read channel 7 to retrieve the peak motor current value.

Medium Voltage Solid State Starter (MV SSS) and Medium Voltage Variable Speed Drive Interface (MV VSD)

These drives communicate with the Microboard via the COM2 RS-485 Modbus serial port (J13). COM2 serial port is selectable between RS-232 and RS-485 with Program Jumper JP17. It must be positioned on pins 1 and 2 to select RS-485 serial port operation. Refer to *FIGURE 16* and YORK Operation and Service manuals *160.00-M5 (MV SSS)* and *Form 160.00-M6 (MV VSD)* for details of this interface. Microboard 031-02430-001 is required for these applications. Software version C.OPT.01.15.xxx (or later) is required for MV SSS. Software version C.OPT.01.16.xxx (or later) is required for MV VSD. When the MV SSS or MV VSD is selected on the SETUP Screen, the COM2 serial port with Modbus protocol is automatically enabled. With the MV VSD, the Adaptive capacity Control functionality is contained on the microboard.

TABLE 4 - MULTIPLEXER CHANNELS

	0	1	2	3	4	5	6	7
CM-2	Gnd	Gnd	Gnd	Gnd	Gnd	Gnd	Gnd	Peak Motor Current (%FLA)

Printer Interface

An optional Printer can be connected to COM1 RS-232 serial data port (J2). J2-4 is TX data to the printer. J2-2 is the DSR (Data Set Ready or busy) signal from the printer. Signal levels are standard RS-232. The microboard sends data to the printer at the selected baud rate until the printer buffer becomes full, whereupon the printer asserts its Busy signal. The microboard suspends data transmission until the printer can accept more data. Each printer must be setup/configured to operate properly with the microboard. The Baud, Data Bits, Parity and Stop Bits must be programmed on the Comms Screen. Other printer setup is performed on the PRINTER Screen. Refer to the *Operating Instructions (Form 160.72-O1)* for details of available printers and printer setup instructions.

E-Link Gateway Interface

An optional E-Link gateway printed circuit board can be connected to the COM 4B RS-232 serial data port (J2). J2-7 is TX data to the E-Link gateway. J2-6 is RX data from the E-Link gateway. Signal levels are standard RS-232. The E-Link gateway polls system pressures, temperatures and status from the microboard. It holds it for retrieval by third-party devices.

Digital Inputs

The YORK I/O Board converts the 115VAC inputs to logic level inputs for the microboard at J19. A 115VAC input to the I/O board is converted to a logic low (less than 1VDC). A 0VAC input to the I/O Board is converted to a logic high (greater than 4VDC).

The Frick I/O board converts the 115VAC input to a logic level input which is processed on the board and is transmitted to the microboard as RS-485 data at J12.

Digital Outputs

The microboard controls 115VAC relays and solenoids with two I/O boards the YORK I/O and the Frick I/O. The YORK I/O via J19 and the Frick via RS-485 data J12. The I/O Board contains +12VDC relays that isolate the microboard low voltage circuits from the 115VAC device coils. Solid state switching devices are used to control the relays. The microboard energizes the +12VDC relays by applying a ground to the coil input. They are de-energized by opening the ground path. The contacts of these relays switch 115VAC to system relays and solenoids. The outputs that control the chilled liquid pump and compressor motor starter have anti-chatter (anti-recycle) timers associated with them. The output that controls relay K0 is not allowed to change at a rate greater than once every 10 seconds. The output that controls relay K13 is not allowed to change at a rate greater than once every 20 seconds.

Analog Inputs

System pressures and temperatures in the form of 4 to 20 mA are inputs from the pressure and temperature transducers to the three Frick analog I/O boards. Formulas and graphs are included to calculate the expected transducer output voltage for a given pressure input.

Serial Data Ports

Microboard 031-02430-000 is equipped with 6 serial data ports. Microboard 031-02430-001 is equipped with 7 serial ports. Refer to *FIGURE 16*. Each port is dedicated for a specific function as follows:

- A. COM1 (J2) – RS-232. Printer
- B. COM2 (J13) – RS-232 on Microboard 031-02430-000. RS-232 or RS-485, as selected with Program Jumper JP17 on Microboard 031-02430-001. The RS-485 port is used for Modbus communications to the Liquid Cooled Solid State Starter, Medium Voltage Solid State Starter, Medium Voltage Variable Speed Drive and Variable Speed Drives. The RS-232 port is not used.
- C. COM3 (J12) – RS-485. Hot Gas Bypass, Heat Recovery, Head Pressure Control, Motor Monitoring
- D. COM4 (4A-J11), (4B-J2) – This port is actually two ports. However, they cannot be used simultaneously. The position of program jumper JP27 determines which port can be used. COM4A – RS485 not used. COM4B – RS-232 E-Link gateway.

- E. COM5 (J15) – Opto-coupled transmit/receive. VSD Adaptive Capacity Control Board or Style B Solid State Starter.

Each port is equipped with two LED's. A red TX LED illuminates as data is transmitted to or requested from another device. A green RX LED illuminates as data is received from another device. The RS-232 voltages are industry standard +5 to +25VDC and -5VDC to -25VDC logic levels. The RS-485 voltages are industry standard 0vdc and +1.5 to +5VDC logic levels. COM5 logic levels are 0VDC and +5VDC. A diagnostic test can be performed on each serial port to confirm proper operation. Refer to the *SECTION 20 - DIAGNOSTICS AND TROUBLESHOOTING* of this manual.

The LED's and their functions are as follows:

- CR2 RX6 – Not used. Future COM6 serial port receive data.
- CR3 TX6 – Not used. Future COM6 serial port transmit data.
- CR4 RX1 – COM1 serial port receive data.
- CR5 TX1 – COM1 serial port transmit data.
- CR13 TX4 – COM4 serial port transmit data.
- CR14 RX4 – COM4 serial port receive data.
- CR15 TX3 – COM3 serial port transmit data.
- CR16 RX3 – COM3 serial port receive data.
- CR17 RX2 – COM2 serial port receive data.
- CR18 TX2 – COM2 serial port transmit data.
- CR19 RX5 – COM5 serial port receive data.
- CR20 TX5 – COM5 serial port transmit data.

Display Interface

The graphic screens displayed on the liquid Crystal Display are created from the program downloaded from the Program Card and stored in the flash memory chip. The data to form these screens is output from J5. This data is in the form of red, green and blue drive signals applied to each of the 303,200 the display pixels arranged in a matrix of 640 columns x 480 rows. Each pixel consists of 3 windows; red, green and blue, through which a variable amount of light from the Display Backlight, is permitted to pass to the front of the display. The drive signals determine the amount of light permitted to pass through each window. The overall pixel color is a result of the gradient of red, green and

blue light allowed to pass. The drive signal for each pixel is an 18 bit binary word; 6 for each of the 3 colors. The greater the binary value, the more light is permitted to pass. The pixels are driven sequentially from left to right, beginning with the top row. To coordinate the drive signals and assure the pixels in each row are driven from left to right and the columns are driven from top to bottom, the drive signals are accompanied by a clock and horizontal and vertical sync signals.

During the boot-up, the program in the BIOS eeprom reads wire jumpers PID0 through PID3 on the Display Interface Board to determine the manufacturer of the display. Each display manufacturer requires a slightly different control. The program in the BIOS eeprom configures the microboard for correct operation for the actual display installed.

Different display manufacturers require different supply and control voltages for their displays and backlights. Program Jumpers JP2 through JP5 and JP7 and JP8 must be configured to provide the required supply and control voltages to the display and backlight control. Program Jumpers lists the required program jumper configuration for each display. Also, a label attached to the display mounting plate lists the required program jumper configuration for that display. The position of program jumper JP2 determines whether the supply voltage is +5VDC or +3.3VDC.

The microboard controls the Display Backlight via J6. The Display Backlight is the light source for the display. The Backlight Inverter Board provides a high voltage AC power source for the lamp. It converts low voltage DC via J6-1 (+12VDC or +5VDC, depending on position of Program Jumper JP5) to high voltage AC (500 to 1500VAC). This high voltage AC is applied to the lamp to cause it to illuminate. The Backlight is turned on and off with the BACKLIGHT ENABLE signal (J6-5). The position of Program Jumper JP4 determines whether this is a +12VDC or +5VDC signal. In some displays, the backlight turns on when this signal transitions from low to high; others turn on when it transitions from high to low. The position of Program Jumper JP3 determines the transition that will occur when the Microboard outputs the Backlight Enable signal. JP3 must be positioned according to the display manufacturer's requirement.

Under program control, the microboard controls the backlight brightness via the Lamp Dimmer circuit output at J6-7. In order to extend the life of the Backlight lamp, the brightness is driven to 50% after 10

minutes of Keypad inactivity. At this brightness level, the graphics are still visible. When Keypad activity is detected (a key is pressed), the lamp is driven back to full (100%) brightness. Some display manufacturers require a variable voltage to vary the brightness; others require a variable resistance. Program Jumpers JP7 and JP8 must be configured to enable the appropriate technique. The Lamp Dimmer is an integrated circuit that is the electrical equivalent of a 10K ohm potentiometer with 100 positions or steps (Refer to *FIGURE 15*). The Lamp Dimmer controls the position of the potentiometer. The Lamp Dimmer varies the brightness of the backlight by applying a variable voltage (0-5.0VDC) or a variable resistance (0-10K ohms) to the Backlight Inverter Board. If Program Jumpers JP7 and JP8 are installed, the lamp Dimmer output is a variable voltage; if both are removed, the output is a variable resistance. The Lamp Dimmer outputs BRIGHTNESS CONTROL WIPER (J6-7) to the Backlight Inverter Board. If configured for variable voltage output, the voltage between J6-7 and J6-8 can be varied from 0VDC (100% brightness) to 5.0VDC (0% brightness). If configured for variable resistance, the resistance between J6-6 and J6-7 varies from 0 ohms (0% brightness) to 10K ohms (100% brightness).

Refer to Display SECTION 6, 7 and 8 of this manual for details of the display interface.

Remote Setpoints

Remote Leaving Chilled Liquid temperature and Current Limit setpoints can be input via the RS-232 E-Link gateway interface at J2 or directly to the Microboard at J22 (Refer to *FIGURE 17*). The inputs at J22 are configured with Program Jumpers JP23 and JP24 to accept these inputs in either 0-10VDC, 2-10VDC, 0-20Ma or 4-20Ma form. Refer to Program Jumper configurations and *SECTION 15 - TEMPERATURE TRANSMITTERS* of this manual for details of the Remote Setpoints.

Configuration/Setup

The following functions are entered as setpoints on one of the SETUP Screen.

- Chilled Liquid Pump Operation – Determines Chilled Liquid Pump control contacts (I/O Board TB2-44/45) operation when chiller shuts down on cycling shutdowns. Selections are:
 1. Standard – Contacts open at completion of SYSTEM COASTDOWN after all shutdowns except LEAVING CHILLED LIQUID – LOW TEMPERATURE. On this

shutdown, they remain closed, causing the pump to continue to run while the chiller is shutdown.

2. Enhanced – Contacts open at completion of SYSTEM COASTDOWN after all shutdowns except LEAVING CHILLED LIQUID – LOW TEMPERATURE, MULTI-UNIT CYCLING- CONTACTS OPEN and SYSTEM CYCLING – CONTACTS OPEN. On these shutdowns, they remain closed, causing the pumps to continue to run while the chiller is shutdown.
- Motor Drive Type – Configures the program for the applicable compressor motor drive type. Selections are:
 1. EM – Electromechanical Starter
 2. MV SSS (microboard 031-02430-001 with software version C.OPT.01.15.xxx (or later))
 - Anti-recycle – Enables or Disables the Anti-recycle timer. CAUTION! The Anti-recycle timer must never be disabled unless advised by YORK Factory. Selections are:
 1. Enabled – Enables the anti-recycle timer.
 2. Disabled – Disables the anti-recycle timer. Chiller can be started at the completion of SYSTEM COASTDOWN, regardless of how long the chiller had been running.
 - Power Failure Restart – Determines the course of action required to restart the chiller, if a power failure occurs while the chiller is running. Selections are:
 1. Manual – Requires a manual reset after power is restored. The chiller cannot be started until the operator moves the keypad Start-Run-Stop/Reset rocker switch to the stop/reset position.
 2. Auto – Chiller will automatically restart when power is restored.
 - Coastdown – Determines the COASTDOWN duration (oil pump run duration after shutdown) and whether the MOTOR CONTROLLER – LOSS

OF CURRENT check and anti-recycle function is performed while the chiller is running. Selections are:

- The protocol selection enables the appropriate communications port: YORK enables COM 5 (J15); MODBUS enables COM 2 (J13). Selection required is based on the hardware and interface that is present. The chiller must be stopped with the Start-Run-Stop/Reset switch in the Stop/Reset position to change this setpoint.

Microboard Service Replacement

If the microboard is replaced within the warranty period, the defective board must be returned to Johnson Controls per the warranty return procedure. Use the return instructions and return address label provided with the replacement board.

To order a replacement Microboard for a OM Chiller, order part number 331-02430-???. This part number provides an 031-02430-001 Microboard that has been programmed with the latest version of the OM CONTROLS software. It comes equipped with a BRAM (U38) and BIOS Eprom (U37). (Replacement Microboards cannot be ordered by the basic board part number of 031-02430-001).

The Microboard is shipped with a label on the outside of the shipping box that lists the part number of the pre-programmed Microboard (331-02430-???), the basic Microboard part number (031-02430-001) and the version of the pre-programmed CONTROLS software (for example, C.OPT.01.14.306 or later).

Microboard 031-02430-000 is supplied as replacement part from January 2004 until June 2006. After this date, microboard 031-02430-001 is supplied. This board is an upgraded version of the 031-02430-000 microboard and is backward compatible to OM chillers presently using the 031-01730-000 or 031-02430-000 microboards. The upgrade includes a larger BRAM and an additional RS-485 port on COM2 for MODBUS serial communications. This upgrade is necessary to operate with those motor drives that communicate with the microboard using Modbus communications: Medium Voltage Solid State Starter (MV SSS).

Summary of differences between 031-02430-000 and 031-02430-001 Microboards:

TABLE 5 - SUMMARY OF DIFFERENCES

	031-02430-000	031-02430-001
BRAM	031-02431-000 (32KB)	031-02565-000 (128KB)
BRAM Socket	28 pin	32 pin
Program Jumper JP14	Non-removable wire	2-pin shunt type w/shunt removed
COM2 Serial Port	RS-232	RS-232 or RS485 as selected w/JP17. RS-485 is required for MVSSS, MVVSD, VSD and Style B LCSSS Modbus communications
Required "Controls" Software Version	Any version	C.OPT.01.15.xxx (or later) (see BRAM transfer exception below). MV VSD and VSD Modbus require C.OPT.01.16.xxx or later, Style B LCSSS MODBUS require C.OPT.01.18.307 (or later)
Application	Except MVSSS, MVVSD, VSD Modbus and Style B LCSSS Modbus	All including MVSSS, MVVSD, VSD Modbus and Style B LCSSS Modbus

When replacing a microboard, it is sometimes desirable to transfer the BRAM from the defective board to the replacement board to save stored Setpoint, History or Sales Order data. Not all BRAM devices are compatible with all Microboards. Also, not all BIOS Eproms are compatible with all Microboards. The board will not function with incorrect memory components. Therefore, before attempting to transfer memory components between boards, refer to the following compatibility chart before proceeding:

TABLE 6 - MICROBOARD

MICROBOARD	BRAM	BIOS EPROM
031-02430-001	031-02565-000*	031-02429-001
031-02430-000	031-02431-000	031-02429-001
031-01730-000	031-02028-000	031-01796-002

*Refer to the following BRAM transfer exception.

Transferring a 32KB BRAM from 031-02430-000 Board to 031-02430-001 Board:

For applications other than MV SSS, the 32KB BRAM (031-02431-000) from a 031-02430-000 board can

be transferred to a 031-02430-001 board. This can be useful when it is desired to transfer a BRAM from one board to another to save stored setpoint, History or Sales Order data. In order to do this, the following must be performed:

1. Install a shunt over Program Jumper JP14. Use an unused black plastic shunt from JP9-12 (DO NOT USE JP1).
2. Install 32KB BRAM toward bottom of the BRAM socket (U38) so that there are 4 empty sockets at the top of the BRAM socket as shown.

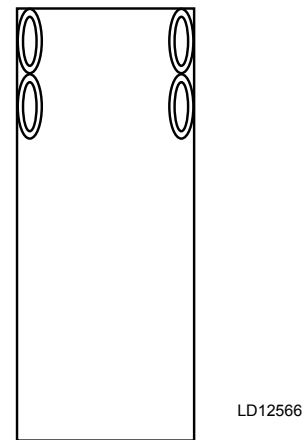

FIGURE 11 - BRAM SOCKET

3. With this configuration, the board can be operated with software versions prior to or later than version C.OPT.01.15.301.

Program Card Service Replacement

Since one OM Program Card can be used to re-program other OM chillers, it is not necessary for an individual Service Technician to have more than one OM Program Card. Program Cards can be shared among Service Technicians where appropriate.

However, since chiller operating programs are occasionally revised, the Service Technician could have a Program Card that does not contain the latest program. Program Cards (031-02474-001) for OM chillers are available from the Baltimore Parts Distribution Center (PDC). The card received from the PDC is programmed with the latest version of the chiller operating program.

Program Cards can be re-programmed with the latest program version.

DOWNLOADING A PROGRAM FROM A PROGRAM CARD

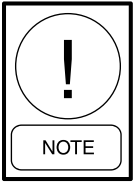

*The Program Card Write Protect Switch must be in the **WRITE PROTECT** position!*



*There are 3 steps to the re-programming process: Erase, Program and Verification. Once the re-programming process is initiated, it automatically proceeds through these steps to completion. It cannot be manually terminated before completion. Therefore, once the process is initiated, the existing on-board program will be erased and replaced by the program in the Program Card. Before proceeding, be absolutely certain the Program Card is applicable to your chiller model. For example, if your chiller is a OM chiller, the Program Card used **MUST** be for a OM chiller. If a YS chiller program is downloaded into a OM chiller, for example, the chiller will be rendered inoperable until this procedure is repeated using the correct Program Card!*

A label affixed to the Program Card contains the card version. The version is an alpha-numeric code that identifies the chiller model applicability, language package and program revision level. The version is as follows:

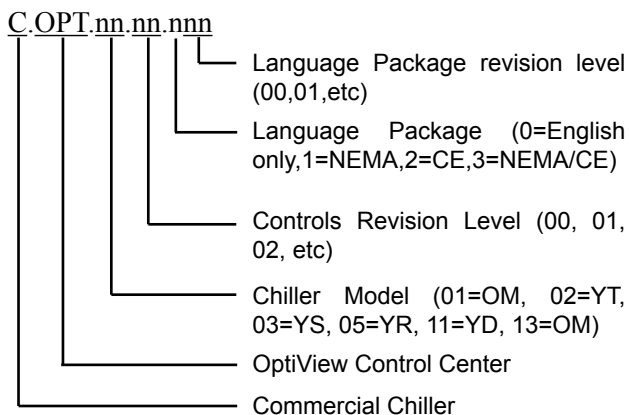

Download the program as follows:

1. Remove power to OptiView Control Center.
2. Remove protective cover from Microboard connector U33.
3. Reposition Microboard Program Jumper JP6 to pins 2 and 3 (left-hand pins).
4. Insert Program Card into Microboard connector U33.
5. Restore power to OptiView Control Center. A white screen appears displaying FLASH CHECKSUM TEST and Microboard 7-segment LED (U22) displays "CH". While this is displayed, the Microboard is performing a checksum test on the Program Card. This assures the integrity of the card before the download procedure can begin. If the checksum test fails, the card is defective or corrupted and the download procedure cannot be performed. If the checksum test passes, the OPTIVIEW FLASH PROGRAMMER Screen is displayed.
6. Press START key to start the downloading process. A dialog box appears asking if you want to ERASE ONBOARD FLASH AND RE-PROGRAM FROM PCCARD? **Do not proceed until you understand the above caution!**
7. Use the ► key to scroll to YES.
8. Press ✓ key. The following steps will be performed:
 - A. Erasing - During this procedure, the program in the Microboard Flash Memory will be erased. A green bar reflects the progress of this procedure. The red LED next to this bar illuminates while this procedure is in progress.
 - B. Programming - During this procedure, the program in the Program Card is downloaded into the Microboard Flash memory. A green bar reflects the progress of this procedure. The red LED next to this bar illuminates while this procedure is in progress.
 - C. Verifying - During this procedure, a checksum test is performed on the new program in the Microboard Flash Memory. A green bar reflects the progress of this procedure. The red LED next to this bar illuminates while this procedure is in progress.

The Microboard 7-segment LED Display (U22) displays the steps of the programming process while they are in effect. During the Erasing procedure, “ER” displayed. During the Programming procedure, “PR” is displayed. During the Verifying procedure, “CH” is displayed.

At the completion of the re-programming process, if it is successful, FLASH HAS BEEN SUCCESSFULLY PROGRAMMED is displayed and OPERATION SUCCESSFUL is displayed in the Status Code box. Otherwise, a message in the status box indicates the step that failed.

9. Remove power from OptiView control center.
10. Remove Program Card from Microboard connector U33.
11. Install protective cover on Microboard connector U33.
12. Reposition Microboard Program Jumper JP6 to pins 1 and 2 (right-hand pins).
13. Apply power to OptiView Control Center. The re-programming procedure is now complete.

PROGRAM JUMPERS

JP1 – Parallel Port Enable/Disable. Used to enable and disable the parallel port in the micro-processor. Since the board is presently not populated with a parallel port connector, this jumper must be in the Disable position.

Pins 1-2: Enables Parallel Port

Pins 2-3: Disables Parallel Port. Must be in this position for correct microboard operation.

JP2 – Display power and logic levels Determines the power supply voltage applied to the display.

Pins 1-2: +5VDC SHARP LQ10D367/368 (031-01774-000) displays. **Pins 2-3:** +3.3VDC SHARP LQ104V1DG61 (031-02886-000) and LG Semicon LP104V2-W (031-02046-000) displays.

JP3 – Display backlight enable signal level polarity.

Jumper must be positioned according to the voltage level required to turn on the Display Backlight. **Pins 1-2:** 0VDC – not used. **Pins 2-3:** +12VDC or +5VDC as determined by position of JP4. SHARP LQ10D367/368 (031-01774-000), SHARP LQ104V1DG61 (031-02886-000) and LG Semicon LP104V2-W (031-02046-000) displays.

JP4 – Display Backlight enable signal logic levels.

Determines the logic levels of the Backlight Enable signal. **Pins 1-2:** +12VDC/0VDC – not used. **Pins 2-3:** +5VDC/0VDC SHARP LQ10D367/368 (031-01774-000), SHARP LQ104V1DG61 (031-02886-000) and LG Semicon LP104V2-W (031-02046-000) displays.

JP5 – Display Backlight power. Determines the power supply voltage applied to the Display Backlight Inverter Board. **Pins 1-2:** +12VDC. SHARP LQ10D367/368 (031-01774-000) and SHARP LQ104V1DG61 (031-02886-000) and LG Semicon LP104V2-W (031-02046-000) displays. **Pins 2-3:** +5VDC. Not used.

JP6 – Boot-up source. Determines whether the boot-up is performed from the Program Card or Eprom U37. **Pins 1-2:** Boots-up from Eprom U37. Must be in this position unless re-programming from the Program Card. **Pins 2-3:** Boots-up from the Program Card. Must be in this position when re-programming from the Program Card.

JP7, JP8 – Display brightness control technique.

Determines whether the display brightness is controlled by a variable resistance or a variable voltage.

IN: Variable voltage (0-5.0VDC). SHARP LQ10D367/368 (031-01774-000) and SHARP LQ104V1DG61 (031-02886-000), and LG Semicon LP104V2-W (031-02046-000) displays.

OUT: Variable resistance – not used

JP9 – Not Used.

JP10 - Factory mounted thermal flow sensor – evaporator. Heat recovery chillers and new production chillers after June 2009.

Pins 1-2: not used

Pins 2-3: Heat Recovery chillers and new production chillers after June 2009

JP11 - Factory mounted thermal flow sensor – condenser. Heat recovery chillers and new production chillers after June 2009.

Pins 1-2: not used

Pins 2-3: Heat Recovery chillers and new production chillers after June 2009

JP12 – Factory mounted thermal flow sensor – heating condenser water. Heat Recovery chillers

Pins 1-2: not used

Pins 2-3: Heat Recovery chillers

JP13 – Watchdog Enable/Disable. Soldered wire jumper.

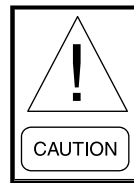

Never disable the watchdog protection. Severe compressor or chiller damage could result. The ability to disable the watchdog protection is provided for factory testing only.

IN: – Watchdog enabled

OUT: – Watchdog disabled

JP14 – BRAM size (Microboard 031-02430-001 only) – Must be positioned according to the size of the BRAM installed on the board.

IN: 32K (BRAM 031-02431-000)

OUT: 128K (BRAM 031-02565-000)

(For 031-02430-000 microboards, this is a non-removable wire jumper soldered in place at time the board is manufactured. It must NOT be removed by field service personnel.

JP16 – Not Used

JP17 – COM 2 Serial port mode (microboard 031-02430-001 only). This port can operate in either RS-232 or RS-485 mode, depending on the position of this jumper.

PINS 1-2: RS-485 (required for MV SSS, MV VSD and those Variable Speed Drives and Style B Liquid Cooled Solid State Starters that communicate with the microboard using Modbus protocol.

PINS 2-3: RS-232 (not used)

JP21 – Factory mounted thermal-type flow sensor – evaporator. Style “F” and later chillers only.

Pins 1-2: Not Used

Pins 2-3: Style “F” and later chillers with factory mounted evaporator thermal-type flow sensor.

JP22 – Factory mounted thermal-type flow sensor – condenser. Style “F” and later chillers only.

Pins 1-2: Not Used

Pins 2-3: Style “F” and later chillers with factory mounted condenser thermal-type flow sensor.

JP23 – Remote Current Limit Setpoint (J22) type. Configures analog input for 0-10VDC, 2-10VDC, 0-20mA or 4-20mA.

OUT: Allows 0-10VDC or 2-10VDC input on J22-1

Pins 1-2: Allows a 0-20mA or 4-20mA input on J22-2

Pins 2-3: Not used.

JP24 – Remote Leaving Chilled Liquid Temperature Setpoint (J22) type. Configures analog input for 0-10VDC, 2-10VDC, 0-20mA or 4-20mA.

OUT: Allows 0-10VDC or 2-10VDC input on J22-3

Pins 1-2: Allows a 0-20mA or 4-20mA input on J22-4

Pins 2-3: Not used.

JP27 – COM 4 serial communications port. Configures COM 4 port for either RS-485 (COM 4A) or RS-232 for the E-Link gateway board (COM4B).

Pins 1-2: Enables port 4A. Allows an RS-485 connection to microboard J11. Not used.

Pins 2-3: Enables port 4B. Allows an RS-232 connection to microboard J2 for the E-Link gateway communications.

4

PROGRAM SWITCHES

SW1-1 – Refrigerant Selection. Must be set according to the refrigerant type installed in chiller.

ON – R134a

OFF – R22

SW1-2 – Liquid Type. Must be set according to whether the chiller is cooling water or brine solution.

ON – Brine. Leaving Chilled Setpoint range is 10°F to 70°F.

OFF – Water. Leaving Chilled Setpoint range 38°F (36°F if Smart Freeze enabled) to 70°F.

SW1-3 – Diagnostics. Enables or Disables the software diagnostics.

ON – Enables diagnostics. Disables normal chiller operation.

OFF – Disables diagnostics. Enables normal chiller operation.

SW1-4 – Not used.

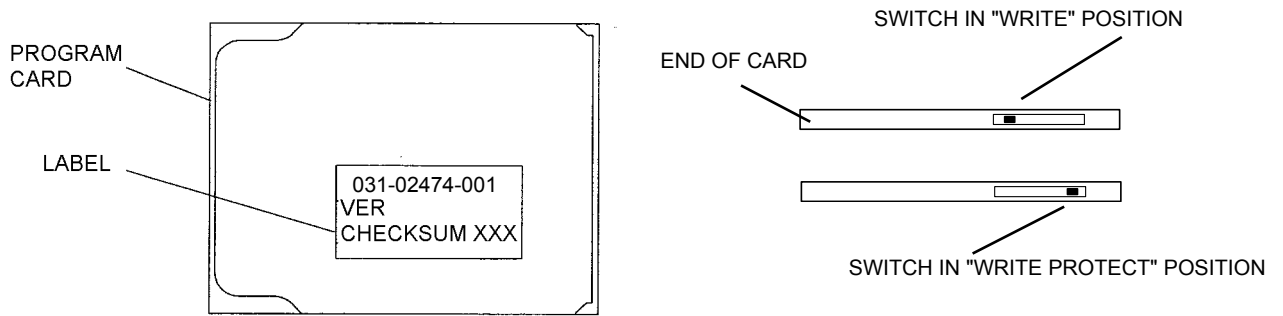
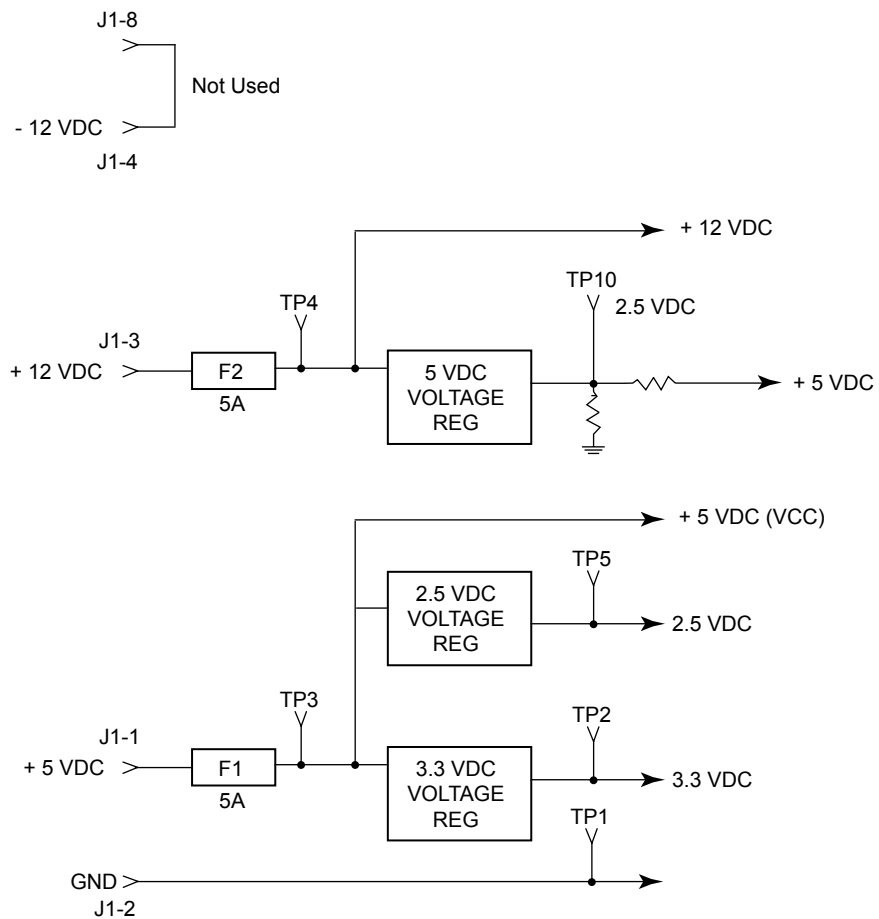
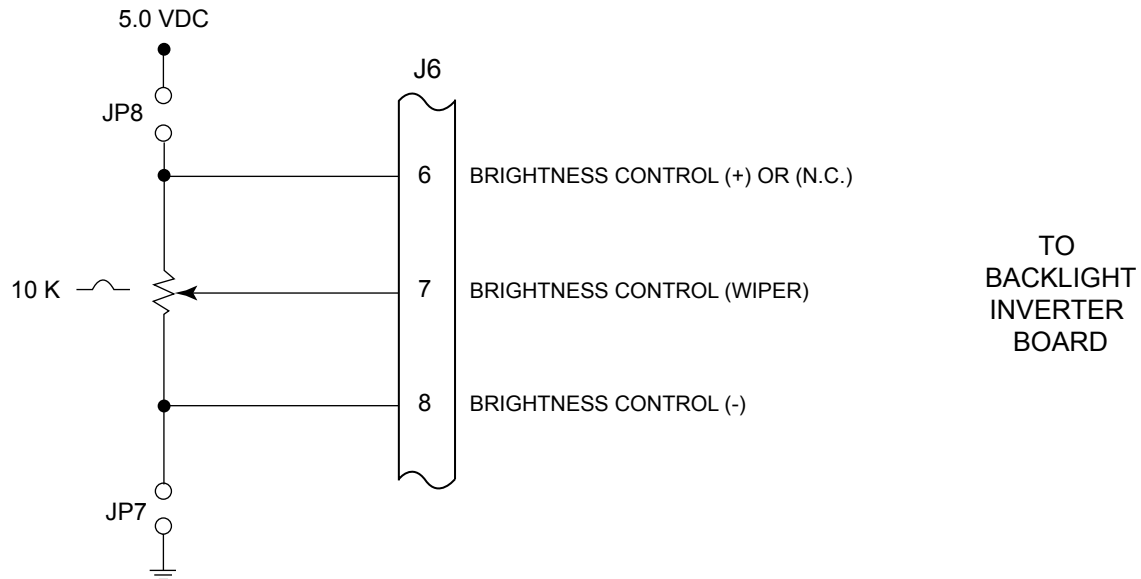



FIGURE 13 - PROGRAM CARD 031-02474-001



LD09255A

FIGURE 14 - MICROBOARD (031-02430-000 AND 031-02430-001) DC POWER SUPPLY TEST POINTS

**NOTES:**

1. J6-6 not connected (N.C.) to Backlight Inverter Board when display is manufactured by Sharp or NEC.
2. The position of Program Jumpers JP7 and JP8 determine the output at J6-7; In = Variable Voltage; Out = Variable Resistance. Refer to Program Jumper Listing for applications.
3. Potentiometer is actually an integrated circuit that is the electrical equivalent of a 10K  potentiometer.

LD04054

FIGURE 15 - MICROBOARD LAMP DIMMER CIRCUIT

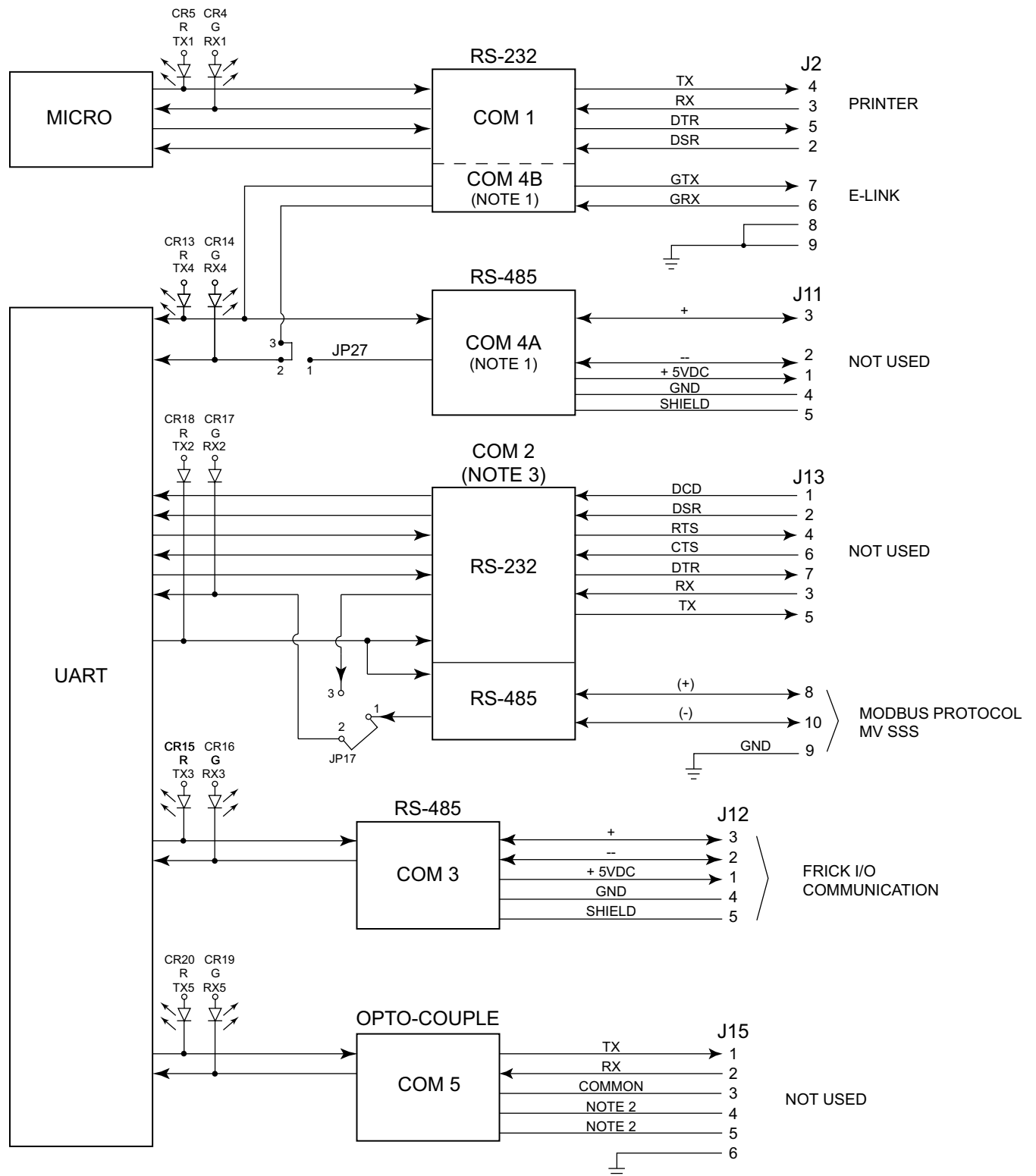

NOTES:

1. Microboard Program Jumper JP27 determines whether COM 4A or 4B can be used. 1 and 2 - 4A, 2 and 3, 4B.
2. J15-4 Loop-Around Test IN. J15-5 Loop-Around Test OUT.
3. The COM 2 port has two selectable serial modes. It can operate in either RS-232 or RS-485 mode, depending upon the position of program jumper JP17 as follows: On pins 1 and 2 for RS-485 operation. On Pins 2 and 3 for RS-232 operation. The COM 2 RS-485 port is not present on 031-02430-000 microboard.

LD07788H

FIGURE 16 - MICROBOARD SERIAL DATA COMMUNICATIONS PORTS

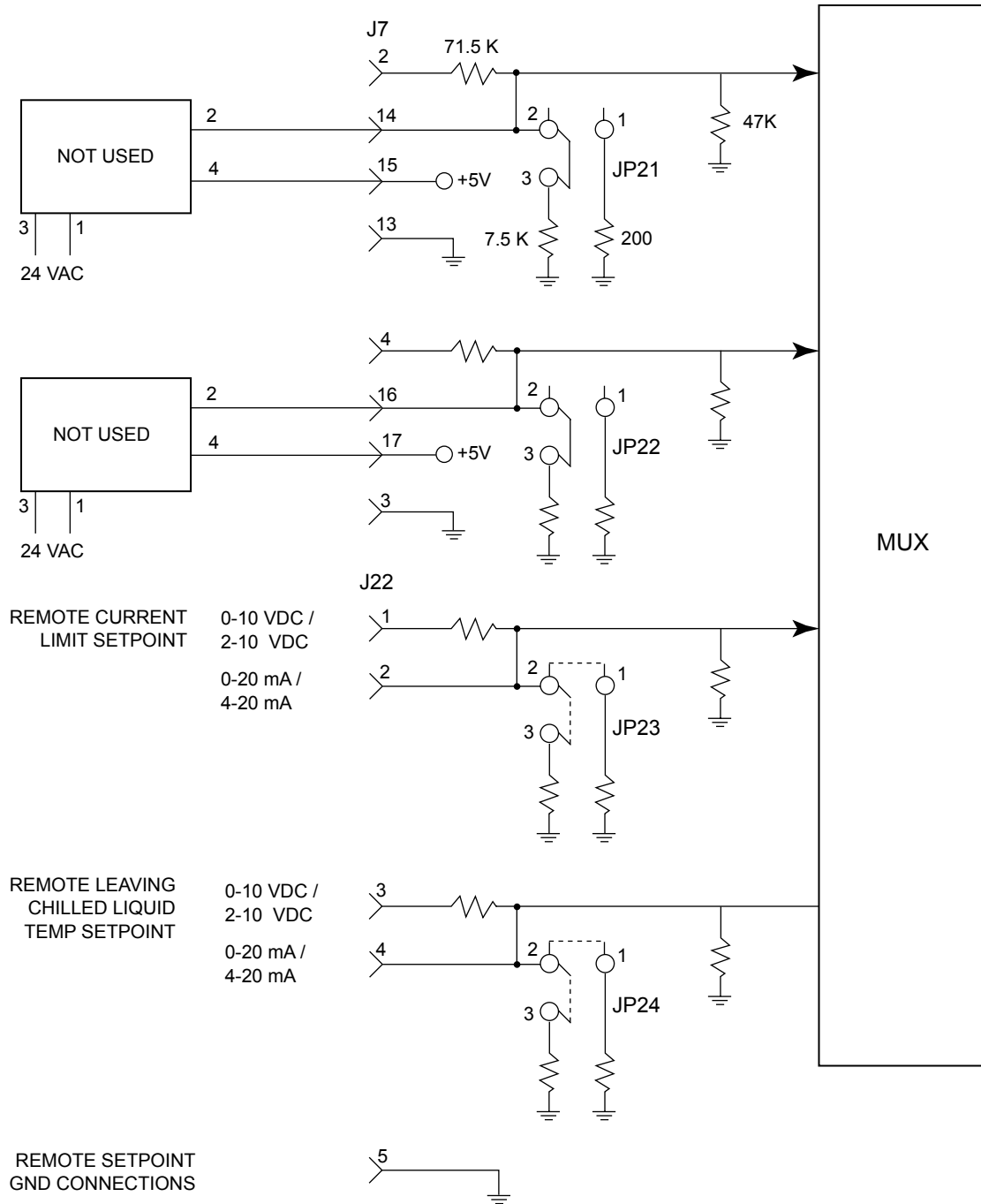

LD09565

NOTE:

1. Program Jumpers JP23 – JP24 must be positioned on pins 1-2 or 3-4 according to input signal type.
2. On new production chillers prior to June 2009, the Thermal type flow sensors are connected to Microboard J7 as shown above. Program Jumpers JP21 and JP22 must be on pins 2-3. On new production chillers after June 2009, the Thermal type flow sensors are connected to Microboard J14 (Refer to FIGURE 18).

FIGURE 17 - CONFIGURABLE ANALOG AND REMOTE SETPOINT INPUTS

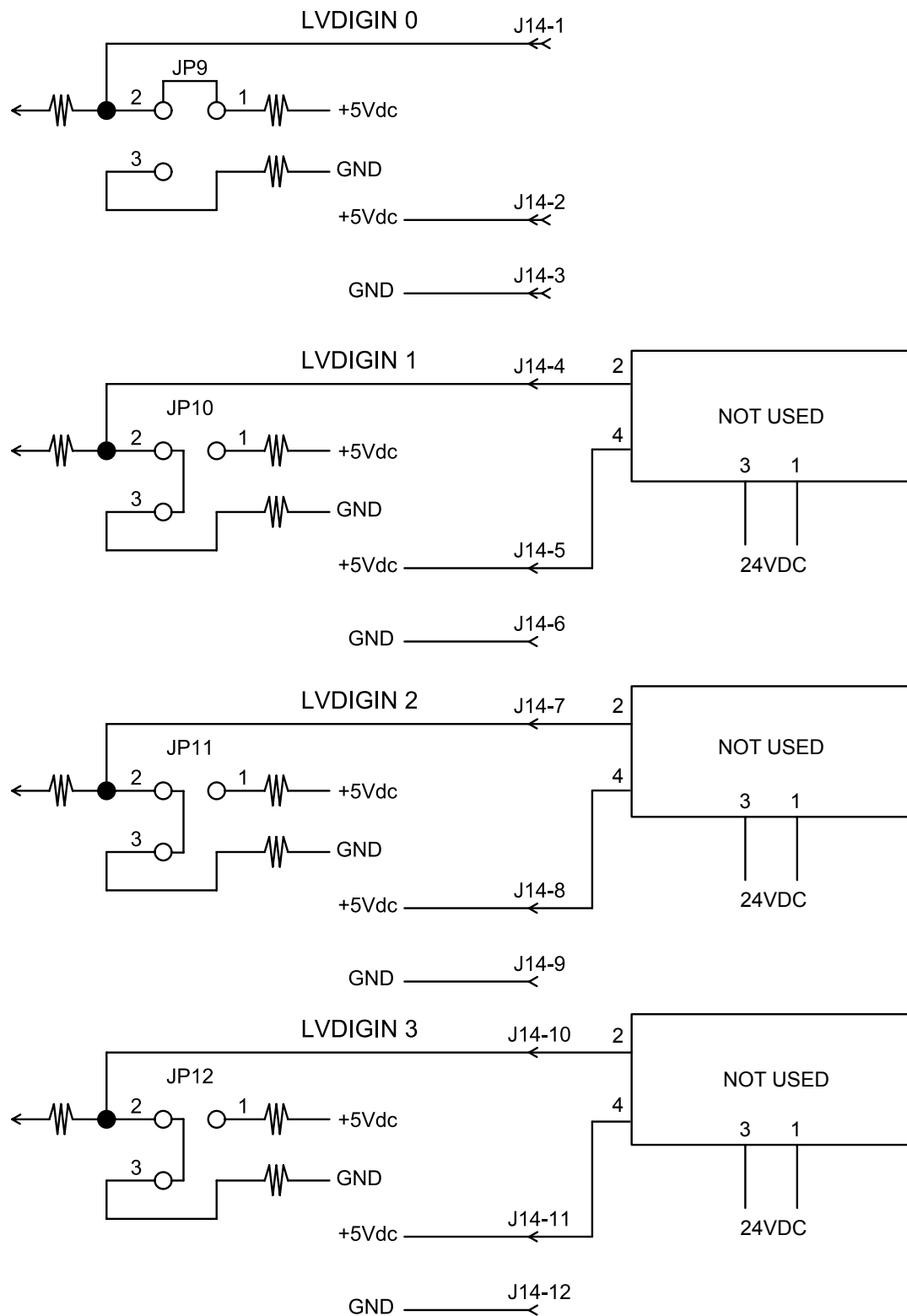

NOTE:

1. On new production chillers after June 2009, the Thermal type flow sensors are connected to Microboard J14 as shown above. Program Jumpers JP10 through JP12 must be positioned on pins 2-3 and software version C.OPT.01.21.307 (and later) is required. On new production chillers prior to June 2009, the Thermal type flow sensors are connected to Microboard J7 (Refer to FIGURE 17).

LD12827a

FIGURE 18 - LOW VOLTAGE DIGITAL INPUTS

THIS PAGE INTENTIONALLY LEFT BLANK.

SECTION 5 - I/O BOARD

The **I/O (input/output) Board** conditions the Digital Inputs for the Microboard and conditions the Microboard's Digital Outputs for application to other components and devices. The left side of the I/O Board performs the Digital Inputs function; the right side performs the Digital Outputs function. Refer to *FIGURE 19*.

Digital Inputs are on/off inputs to the Microboard from relay and switch contacts, such as flow switches, start/stop switch, and remote cycling/safety devices (Refer to *FIGURE 20*). The Micro reads the state of these contacts and reacts per the Program instructions. The contact voltage is 115 VAC when closed and 0VAC when open. These voltages are not suitable for direct input to the Microboard. Therefore, the I/O Board converts the 115VAC/0VAC contact voltages to 0VDC/+5VDC logic level inputs for the Microboard. Individual Optocoupler circuits (Refer to *FIGURE 21*) perform the conversion for each Digital Input. When the input is 115VAC, the output will be 0VDC; when the input is 0VAC, the output will be +5VDC.

Field connected Digital Inputs, such as those from external devices that cycle the chiller, are connected to terminal strip TB4 (Refer to *FIGURE 20*). These inputs are in the form of dry contacts connected as shown in *FIGURE 22*. The 115VAC power source that is switched by the remote contacts is supplied by the I/O Board TB4-1. There are multiple TB4-1 terminals located adjacent to the field input connections, as shown in *FIGURES 19* and *20*.

Digital Outputs are on/off outputs from the Microboard that control solenoid valves, motor contactors, actuators, system relays and provide operating status to external devices (Refer to *FIGURE 23*). Per Program instructions, the Microboard energizes and de-energizes these devices. The coils of these devices operate on 115VAC and therefore cannot be directly connected to the Microboard. The Digital Outputs section of the I/O Board contains +12VDC coil relays that are driven by the Microboard's logic level outputs. The contacts of these +12VDC relays operate the external 115VAC coil devices. On the I/O Board, one side of each of the relay coils is permanently connected to +12VDC at J19-26/27. The other side of each relay coil is connected to the Microboard via I/O Board connector J19. The Microboard energizes each relay by driving the appropriate input at J19 to logic low voltage level (ground

potential). The DC voltage at the appropriate input pin at J19 will be a logic high (greater than +10VDC) when the Microboard is commanding a relay to de-energize; logic low (less than +1VDC) when commanding a relay to energize.

Relay K18 is different from all other relays on the I/O Board; it has a 115VAC coil. It provides the start/stop signal to the Compressor Motor Starter and provides **Compressor Run** status to remote devices (Refer to *FIGURE 23*). Relay K18 is controlled by DC relays K13 (start) and K14 (stop). To start the compressor motor, the Microboard energizes K13 and K14 simultaneously. The 115VAC at TB1-6 is applied to the coil of K18 via K13 contacts, energizing K18. Approximately 0.2 seconds later, K13 is de-energized. K18 remains energized through K14 contacts and holding contacts of K18. To stop the compressor motor, the Microboard de-energizes K14. To prevent sags in Utility Power from chattering K18, the holding contact of K18, along with the contact of K13, creates an anti-chatter circuit for relay K18. Once energized, K18 cannot be re-energized until K13 is again energized; this will not occur until after a controlled shutdown has occurred and another start sequence has been initiated.

There are conditions external to the I/O Board required to energize relay K18. The 115VAC will be present at TB1-16 only if the motor controller contacts "CM" are closed and the circuit between external Terminal Strip TB6-1 and TB6-53 is closed. The "CM" are located on the CM-2 Board (relay K1), Electro-Mechanical starter applications, the Solid State Starter Logic Board (relay K1), Solid State Starter applications or a relay mounted on the Variable Speed Drive Logic Board on Variable Speed Drive applications. The High Pressure safety switch "HP", must be closed and the **RUN** Switch "1SS" must be in the **Run** position.

RELAY TIMING

Under Program control, the relays are energized and de-energized producing contact operation as follows. Unless otherwise noted, contact rating is 5 amps resistive or 2 Amps inductive @ 250VAC.

K0 - Chilled Water Pump Starter (TB2-44/45)

Dry closure contacts. When the chiller is started, the Contacts close 13 seconds after the start of SYSTEM PRELUBE. Normally, they open coincident with the

completion of SYSTEM COASTDOWN with the following exceptions:

- A. If a LEAVING CHILLED LIQUID - LOW TEMPERATURE cycling shutdown occurs, they do not open at the completion of SYSTEM COASTDOWN. They remain closed for the duration of the shutdown or until the Keypad COMPRESSOR switch is placed in the Stop-Reset (O) position, whereupon they open.
- B. If Microboard Program Switch SW1-8 is in the ON position, they do not open at the completion of SYSTEM COASTDOWN when the chiller shuts down on a MULTIUNIT CYCLING - CONTACTS OPEN or SYSTEM CYCLING - CONTACTS OPEN cycling shutdown. They remain closed for the duration of the shutdown or until the Keypad COMPRESSOR switch is placed in the Stop-Reset (O) position, whereupon they open.

K1 - Anticipatory Alarm (TB2-55/56)

Dry closure contacts. Contacts close when one of the following Warning messages is Displayed. On most warnings, the contacts automatically open when the warning condition is no longer present. On those warnings marked with an asterisk, the contacts will open only after the warning condition is no longer present and the WARNING RESET key is pressed when logged in at OPERATOR access level or higher.

K2 - Remote Mode Ready to Start (only operational in Digital, Analog or BAS Remote mode)(TB2-26/27)

Dry closure status contacts that are closed to indicate to a Remote device that the chiller will start upon receipt of a remote start signal. The contacts open coincident with any Cycling or Safety shutdown or anytime the Keypad COMPRESSOR switch is placed in the Stop-Reset (O) position. On Cycling shutdowns, the contacts will close when the cycling condition clears. On safety shutdowns, the contacts will close only after the Safety condition clears, a manual reset is performed by placing the COMPRESSOR switch in the Stop-Reset (O) position and then back to the RUN (I) position.

K3 - Safety Shutdown Status (TB2-42/43)

Dry closure status contacts. They close coincident with a Safety shutdown. They remain closed until the safety condition clears and a manual reset is performed by placing the COMPRESSOR switch in the Stop-Reset(O) position, whereupon they open.

K4 - Cycling Shutdown Status (TB2-40/41)

Dry closure status contacts. They close coincident with a Cycling shutdown. They remain closed until the cycling condition clears, whereupon they open.

K5 - Condenser Motor Pump Starter (TB2-150/151) (applies to Flash Memory Card version C.MLM.01.04.xxx and later)

Dry closure contacts. Contacts close coincident with beginning of SYSTEM RUN. They open coincident with the beginning of SYSTEM COASTDOWN unless the chiller is equipped with the Mod "B" Solid State Starter. On Mod "B" Solid State Starter applications, the contacts remain closed at shutdown until all SCR Heatsink temperatures are less than or equal to 105°F or a maximum of 45 minutes.

If it is desired to supply the dry contacts with 115VAC power from the OptiView Control Panel to control the Condenser Pump Motor Starter, a field installed wire must be connected from TB5-22 to I/O Board TB2-150. Then connect I/O Board TB2-151 to the Condenser Pump Motor Starter.

K6-K 9 - Not Used

K10 - Oil Heater (TB1-64/17)

K11 - Oil Pump Starter (TB 1-29/1) (Style "C" and earlier chillers)

In automatic operation, contacts close 13 seconds after SYSTEM PRELUBE is initiated. Contacts open at completion of SYSTEM COASTDOWN. In manual Oil Pump operation, the contacts close for the duration of manual pump operation. Anytime the chiller is not in SYSTEM RUN or SYSTEM COASTDOWN and a motor current value of greater than 15%FLA is detected, the contacts close until motor current is no longer detected, whereupon a complete SYSTEM COASTDOWN is performed. If Standby Lubrication is enabled, contacts close for 2 minutes every 24 hours since the oil Pump was last automatically or manually run.

K12 - Oil Return Solenoid (TB1-61)

Contacts close 1minute after SYSTEM RUN is initiated. They open on chiller shutdown coincident with the beginning of SYSTEM COASTDOWN.

**K13 - Compressor Motor Starter (start)
(TB1-6/16)**

Contacts close coincident with the beginning of SYSTEM RUN. They remain closed for 0.2 seconds and then open.

**K14 - Compressor Motor Stop (stop)
(TB 1-6/16)**

Contacts close coincident with the beginning of SYSTEM RUN. They remain closed for the duration of SYSTEM RUN. They open coincident with the beginning of SYSTEM COASTDOWN.

**K15 Compressor Sump Vent Valve – (TB1 –
34/1)**

Contacts close when the compressor starts and energizes the pneumatic solenoid valve the supplies air to the compressor sump vent valve. The compressor sump vent valve is timed open by an adjustable needle valve restrictor which is field calibrated to the proper value.

**K18 - Compressor Motor Starter (TB5-22/25)
Run Status (TB2-35/36)**

Contacts operate the same as K14.

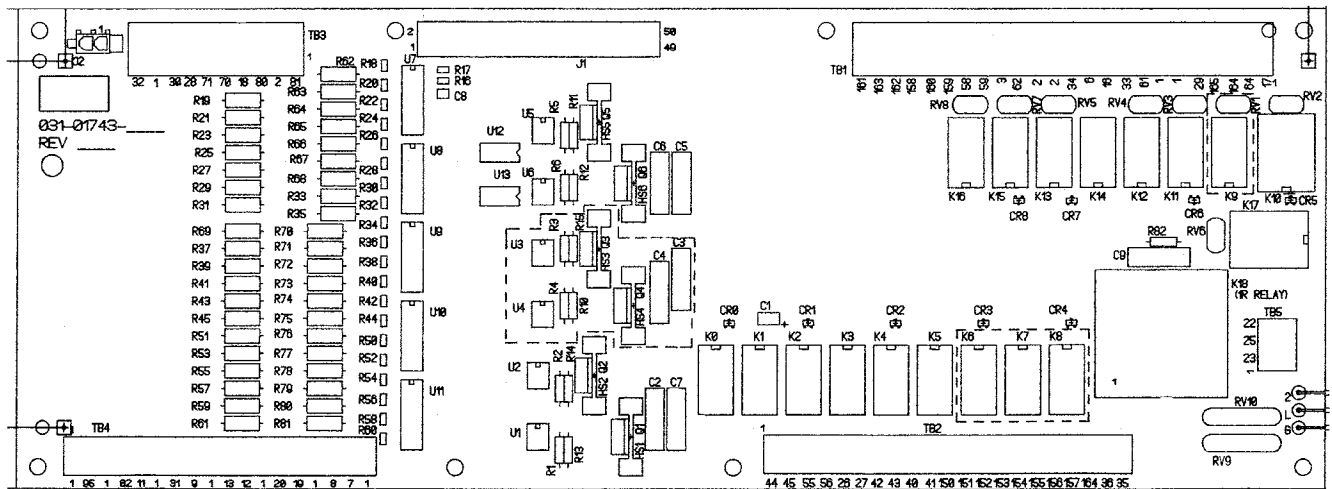

FIGURE 19 - I/O BOARD

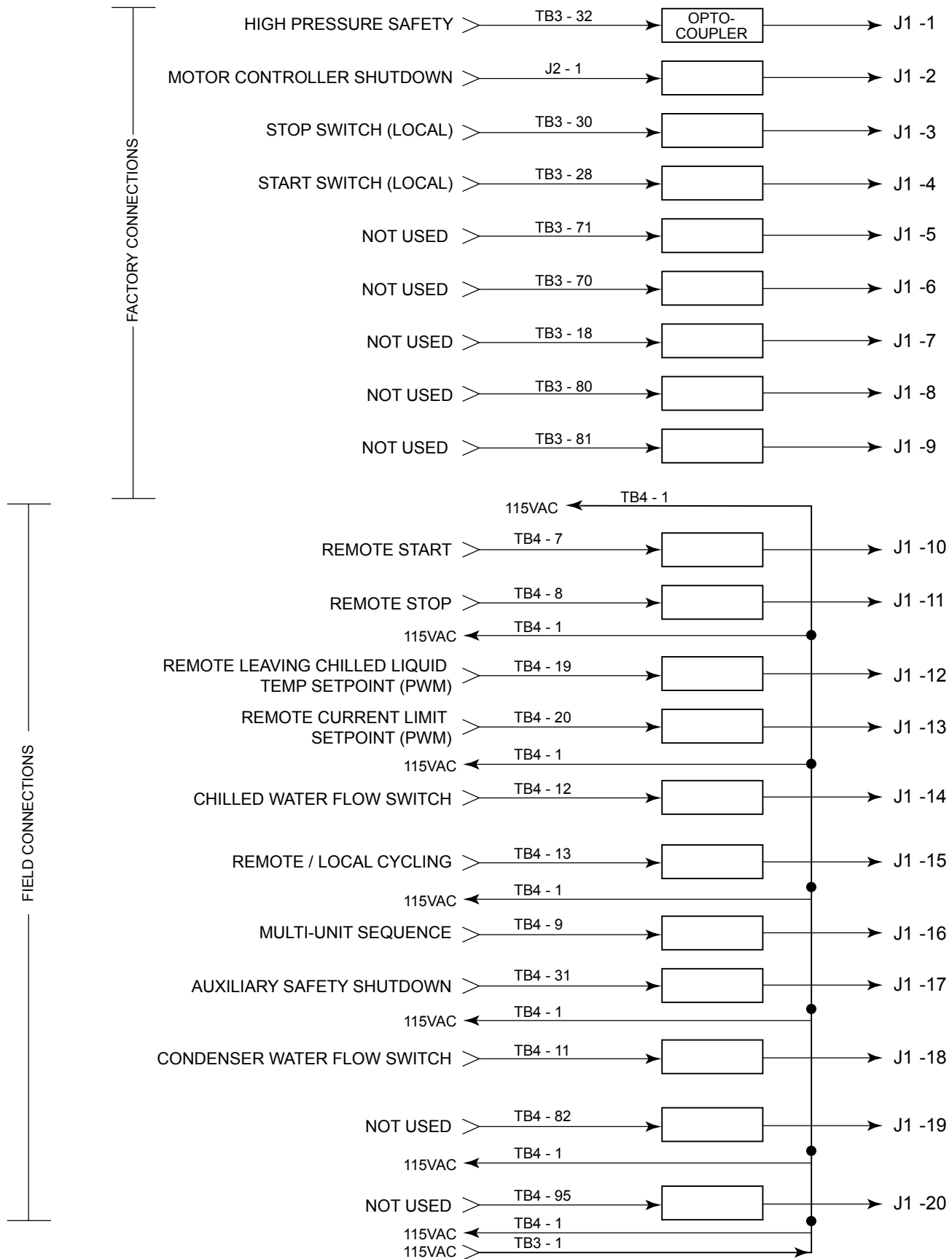
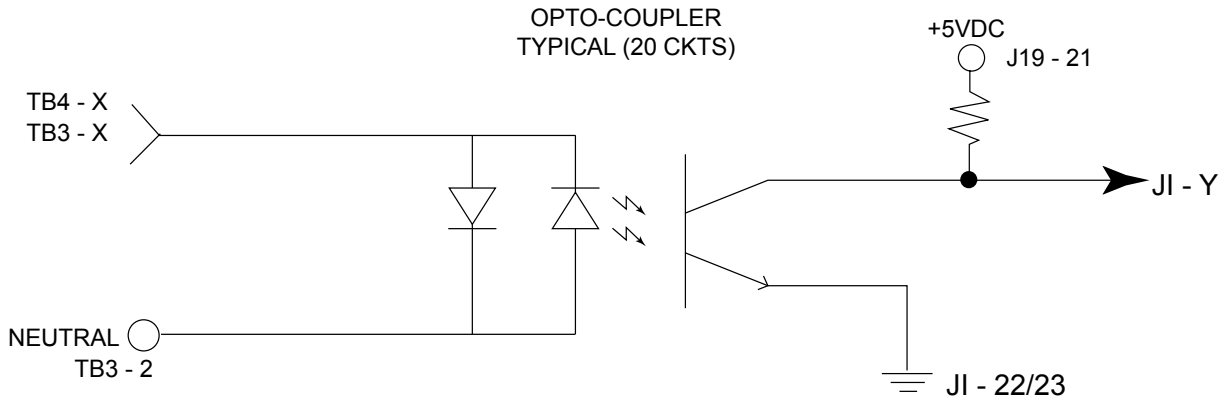

FIGURE 20 - I/O BOARD DIGITAL INPUTS

LD09566



5

LD04057

FIGURE 21 - I/O BOARD TYPICAL OPTO-COUPLER CIRCUIT

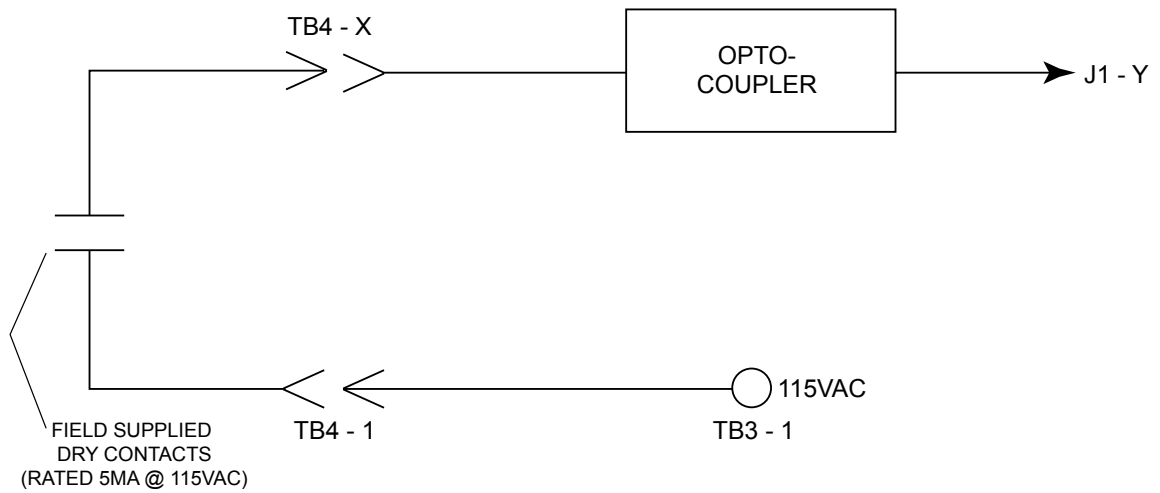

LD04058

FIGURE 22 - I/O BOARD TYPICAL FIELD CONNECTIONS

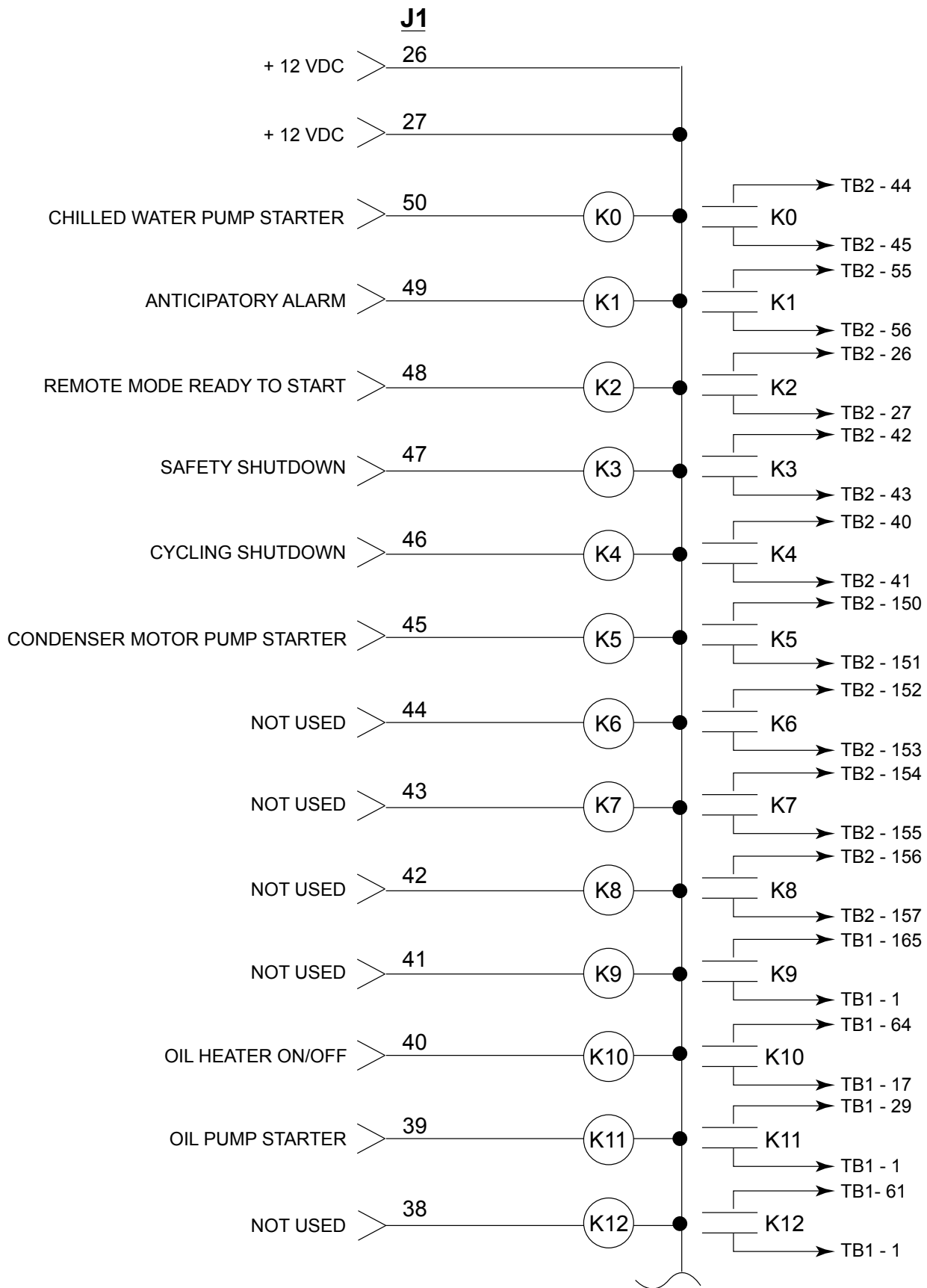

LD09042

FIGURE 23 - J1 I/O BOARD DIGITAL OUTPUTS

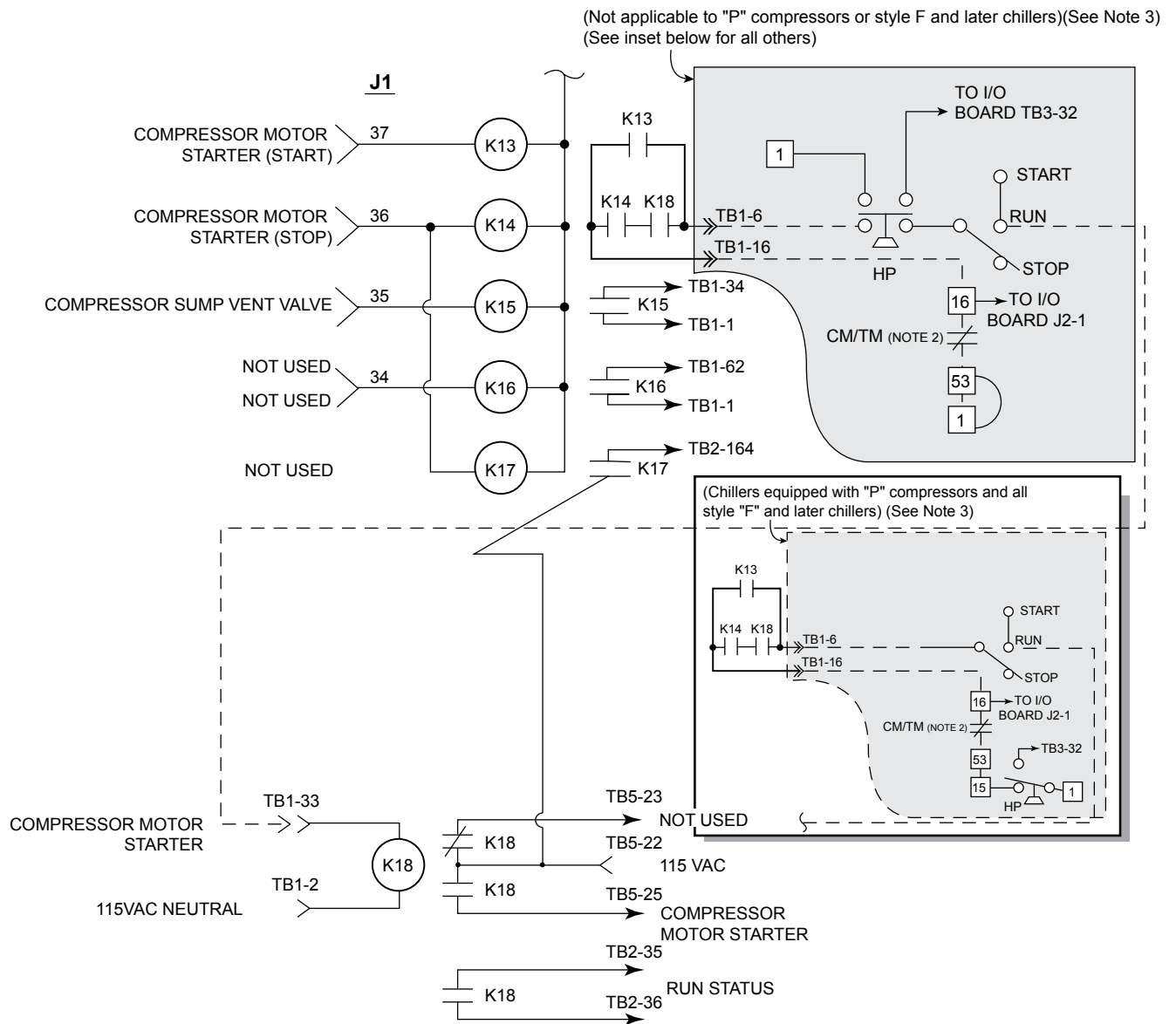

NOTES:

1. "CM" – Contacts of Relay K1 on Current Module (EM Starter Applications) or Solid State Starter Logic Board (Solid State Starter Applications) or VSD Logic Board (Compressor Motor Variable Speed Drive Applications).

LD09043

FIGURE 24 - J1 I/O BOARD DIGITAL OUTPUTS

THIS PAGE INTENTIONALLY LEFT BLANK.

SECTION 6 - LIQUID CRYSTAL DISPLAY

A 10.4 inch color **Liquid Crystal Display**, along with supporting components **Display Interface Board** and **Backlight Inverter Board** are mounted on a plate that is attached to the OptiView Control Center door. A clear plexiglass faceplate prevents display surface damage. System operating parameters are displayed on various color graphic screens. The various display screens are selected for display using the Keypad keys.

The Display provided in the new chiller or from YORK as a service replacement part, could be manufactured by any of several approved manufacturers. Each Display requires a specific Display Interface Board, Backlight Inverter Board, Inverter Board interface cable and Program command set. **Therefore, Service replacement Displays or supporting components cannot be arbitrarily selected!!!** As explained below, replacement Displays are provided from YORK as kits to assure compatibility of all components. **Non-compatibility of components will result in incorrect operation!!!** Refer to *SECTION 7 - DISPLAY INTERFACE BOARD* and *SECTION 8 - DISPLAY BACKLIGHT INVERTER BOARD* that follow this section. Displays that could be provided from YORK in new chillers or as replacement parts are:

- SHARP LQ104V1DG61 (031-02886-000)
- SHARP LQ10D367/368 (031-01774-000)
- LG SEMICON LP104V2-W (031-02046-000)

The YORK Part Numbers of the Display Interface Board, Backlight Inverter Board and Inverter ribbon cable provided, are listed on a label attached to the Display mounting plate. These are the part numbers of the supporting components that are compatible with the installed display. These supporting components can be individually replaced. However, if the Liquid Crystal Display fails, Display replacement kit 331-01771-000 must be ordered as detailed below. This kit contains a replacement Display and all compatible supporting components.

The Display has 307,200 pixels arranged in a 640 columns X 480 rows matrix configuration. Each pixel consists of 3 windows; red, green and blue, through which a variable amount of light from the Display Backlight is permitted to pass through the front of the display. Imbedded in each window of the pixel is a transistor, the conduction of which determines the amount of light that will pass through the window. The conduction of

each transistor is controlled by a signal from the Display Controller on the Microboard. The overall pixel color is a result of the gradient of red, green and blue light allowed to pass.

Under Program control, the Display Controller on the Microboard sends a drive signal for each pixel to create the image on the display. Each pixel's drive signal is an 18 bit binary word; 6 bits for each of the 3 colors, red green and blue. The greater the binary value, the greater the amount of light permitted to pass. The columns of pixels are driven from left to right and the rows are driven top to bottom. To coordinate the drive signals and assure the columns are driven from left to right and the rows are driven from top to bottom, each drive signal contains a horizontal and vertical sync signal. The **Display Interface Board** receives these display drive signals from the Microboard J5 and applies them to the Display at connector J1. Refer to *FIGURE 32*.

Although there are variations in control signal timing between different display manufacturers, *FIGURE 29* depicts typical control signals. Since these control signals occur at rates greater than can be read with a Voltmeter, the following description is for information only. There are 480 horizontal rows of pixels. Each row contains 640 3-window pixels. Beginning with the top row, the drive signals are applied within each row, sequentially left to right, beginning with the left most pixel and ending with the right most pixel. The rows are driven from top to bottom. The Vertical Sync (VSYNC) pulse starts the scan in the upper left corner. The first Horizontal Sync (HSYNC) pulse initiates the sequential application of RGB drive signals to the 640 pixels in row 1. Upon receipt of the **ENABLE** signal, an RGB drive signal is applied to the first pixel. As long as the **ENABLE** signal is present, RGB drive signals are then applied to the remaining 639 pixels at the CLK rate of 25.18M Hz, or one every 39.72 nanoseconds. Typically it takes 31 microseconds to address all 640 pixels. Similarly, the next HSYNC pulse applies drive signals to row 2. This continues until all 480 rows have been addressed. Total elapsed time to address all 480 rows is approximately 16 milliseconds. The next VSYNC pulse causes the above cycle to repeat. Displays can be operated in **FIXED** mode or **DISPLAY ENABLE** mode. In **FIXED** mode, the first pixel drive signal is applied a fixed number (48) of clock (CLK) cycles from the end of the HSYNC pulse and the drive signals are terminated a fixed number (16) of CLK

cycles prior to the next HSYNC pulse. In **DISPLAY ENABLE** mode, the pixel drive signals are applied to the pixels only while **ENABLE** signal is present. This signal is typically present 4-48 CLKS after the end of the HSYNC pulse and 2-16 CLKS prior to the next HSYNC pulse. All YORK applications operate in the **DISPLAY ENABLE** mode. The state of the **ENABLE** (Display Interface Board J1-27) signal from the Microboard places the Display in the desired mode as follows:

- SHARP LQ10D367/368 (031-01774-000) and LQ104V1DG61 (031-02886-000) Displays - When **ENABLE** maintained “low”, display operates in fixed mode.
- LG SEMICON Display (031-02046-000) does not have the fixed mode feature.

As described above, in OptiView Control Center applications, the Display scan is left to right, beginning with the top row and continuing sequentially through the rows to the last row. However, in Display applications other than OptiView Control Centers, image reversal is sometimes required. In image reversal applications, the scan is reversed; the scan is right to left, beginning with the last row and proceeding to the top row. The scan mode is determined by the configuration of wire jumpers on the Display Interface Board (Refer to *SECTION 7 - DISPLAY INTERFACE BOARD*).

Displays by different manufacturers can require different timing and control signals. The Microboard must know which Display is present in order provide the correct signals. Therefore, when AC control power is first applied to the OptiView Control Center, as part of the power-up sequence, the Microboard reads the Panel ID wire jumpers P1D0 - P1D3 on the **Display Interface Board** and determines which Display is present. It can then provide the correct timing and control signals to produce the graphic image, as required by the Display manufacturer. Since the **Display Interface Board** identifies the Display for the Microboard, there is a different **Display Interface Board** required for each Display application and each has a unique jumper configuration that identifies the Display. A complete explanation of this process is included in the preceding *SECTION 3 - MICROBOARD 031-01730-000* and *SECTION 7 - DISPLAY INTERFACE BOARD*.

The DC power source to operate the Display is provided by the Microboard J5. Some Display manufacturers require +5VDC; others require +3.3VDC. The position of Microboard Program Jumper JP2 determines which

of these power sources is supplied to the Display. JP2 must be positioned according to the Display manufacturers requirements.

The **Backlight Lamp** provides the illumination for the display. Average lamp life is 25000 hours (2.9 years). Some displays use one lamp. Others use two lamps. Lamps are replaceable, but not interchangeable between different displays. Each Display manufacturer specifies the required lamp for their display. Refer to replacement parts list for appropriate replacement lamp. Service replacement lamps are stocked in the Baltimore Parts Center. The lamp is illuminated by applying a high voltage AC (500 to 1500VAC) to it. This illumination voltage is created from a low level DC voltage (+12VDC or +5VDC as required by the Display manufacturer) by the **Backlight Inverter Board**. Lamp brightness is controlled by varying the high voltage AC. The greater the voltage the brighter the illumination. The lamp is controlled by on/off commands and brightness control signals applied to the **Backlight Inverter Board** from the Microboard. The Microboard Program determines when the lamp is turned on and off and the lamp brightness. Each Display manufacturer specifies the **Backlight Inverter Board** to be used. Therefore, it will vary according to the Display manufacturer. The ribbon cable that connects the Microboard to the Backlight Inverter Board also varies according to the Display manufacturer's requirements. Refer to *FIGURE 33 to 35*. Microboard Program Jumpers JP3, 4, 5, 7 and 8 determine the voltage levels of the control signals sent to the **Backlight Inverter Board** and must be configured per the Display manufacturer's requirements. A detailed description of the operation of this board is in *SECTION 8 - DISPLAY BACKLIGHT INVERTER BOARD*. Also refer to the preceding *MICROBOARD* section for a detailed description of the **Lamp Dimmer** circuit.

The actual Display that is installed in the OptiView Control Center of the new chiller is determined by the Display manufacturer contractual agreement in place during the time of OptiView Control Center production. Displays stocked for Service replacement are a result of that same agreement. Therefore, the Display received for service replacement may be by a different manufacturer than the one in the OptiView Control Center. Since each Display manufacturer requires a specific Display Interface Board, Backlight Inverter Board and Inverter Ribbon Cable, replacement Displays are ordered and supplied as a Display Replacement Kit (YORK Part Number 331-01771-000) to as-

sure component compatibility. The items supplied in the kit are compatible with the supplied Display. The kit consists of the following items mounted on a Display mounting plate:

Display Replacement Kit 331-01771-000

1. Liquid Crystal Display with Lamp
2. Appropriate Display Interface Board for item 1
3. Appropriate Backlight Inverter Board for item 1
4. Appropriate ribbon cable (Backlight Inverter Board to Microboard) for item 1
5. Ribbon cable (Display Interface Board to Microboard)
6. All mounting hardware
7. Installation instructions. A label attached to the Display mounting plate lists the YORK Part Numbers of the Display supporting components mounted on the Display mounting plate and the required Microboard Program Jumper (JP2 through 8) configurations. **Microboard Program Jumpers JP2- JP8 will have to be configured appropriately for the replacement display.**

Display Handling

1. The display is made of glass. It could break if dropped.
2. The display front surface is easily scratched. If soiled, wipe with a dry cotton cloth. Use no water or chemicals.
3. The display is static sensitive. Electrostatic discharges may damage the display.
4. A laminated film is adhered to the display front glass surface to prevent it from being scratched. Peel off very slowly to prevent static damage.



Always remove control power from the OptiView control center before connecting or disconnecting wires to the display. Connecting or disconnecting wires to the display with power applied will damage the display!!!

BACKLIGHT LAMP REPLACEMENT

SHARP LQ10D367/368 (031-01774-000) Display: (Refer to FIGURE 30)

Removal

The Lamp slides into the Display from left to right and is secured with a locking tab.

1. Remove Control Power from the OptiView Control Center.
2. Remove protective cover from rear of Display.
3. Disconnect Lamp AC power connector from Backlight Inverter Board.
4. Using fingernail or thin flat blade screwdriver, bend the locking tab outward slightly to clear the Lamp housing protrusion.
5. Grasp Lamp AC power connector and gently pull until Lamp housing clears locking tab.
6. Grasp Lamp housing and pull until Lamp housing is completely removed from the Display.

Installation

1. Slide new Lamp into Display from left to right until Lamp housing protrusion locks into Display locking tab.
2. Connect Lamp AC power connector to Backlight Inverter Board.
3. Apply Control Power to OptiView Control Center.

**LG Semicon LP104V2-W (031-02046-000) and
SHARP LQ104V1DG61 (031-02886-000)
Display (Refer to FIGURE 31)**

Removal

The Lamp slides into the Display from left to right and is secured with a screw.

1. Remove Control Power from the OptiView Control Center.
2. Remove protective cover from rear of Display.
3. Disconnect Lamp AC power connector from Backlight Inverter Board.
4. Using small Phillips screwdriver, remove lamp retaining screw.

5. Grasp Lamp AC power connector and gently pull until Lamp housing is completely removed from the Display.

Installation:

1. Slide new Lamp into Display from left to right until Lamp housing is fully inserted.
2. Secure Lamp with Lamp retaining screw.
3. Connect Lamp AC power connector to Backlight Inverter Board.
4. Apply AC power to OptiView Control Center.

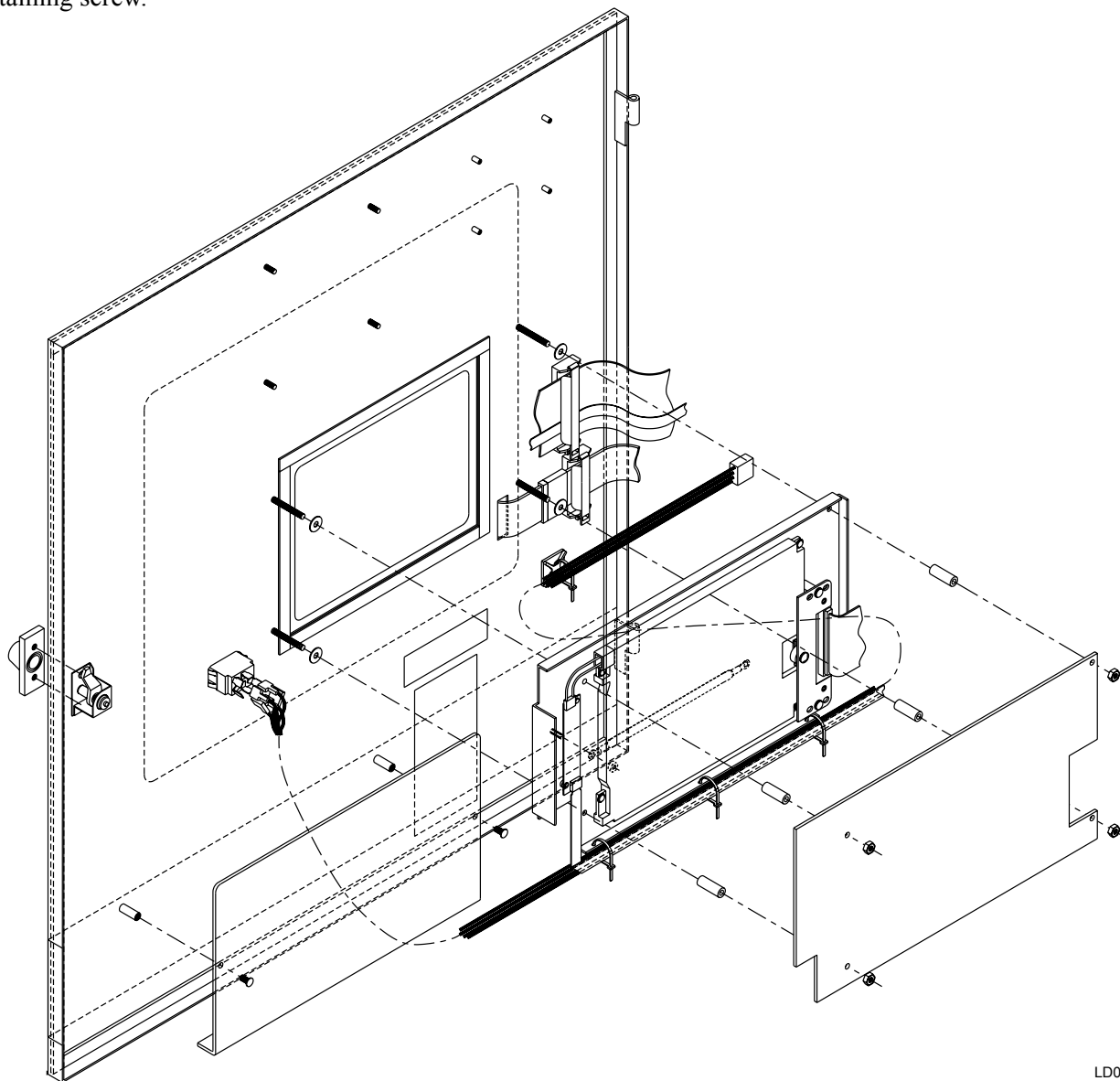

LD04062

FIGURE 25 - DISPLAY MOUNTING

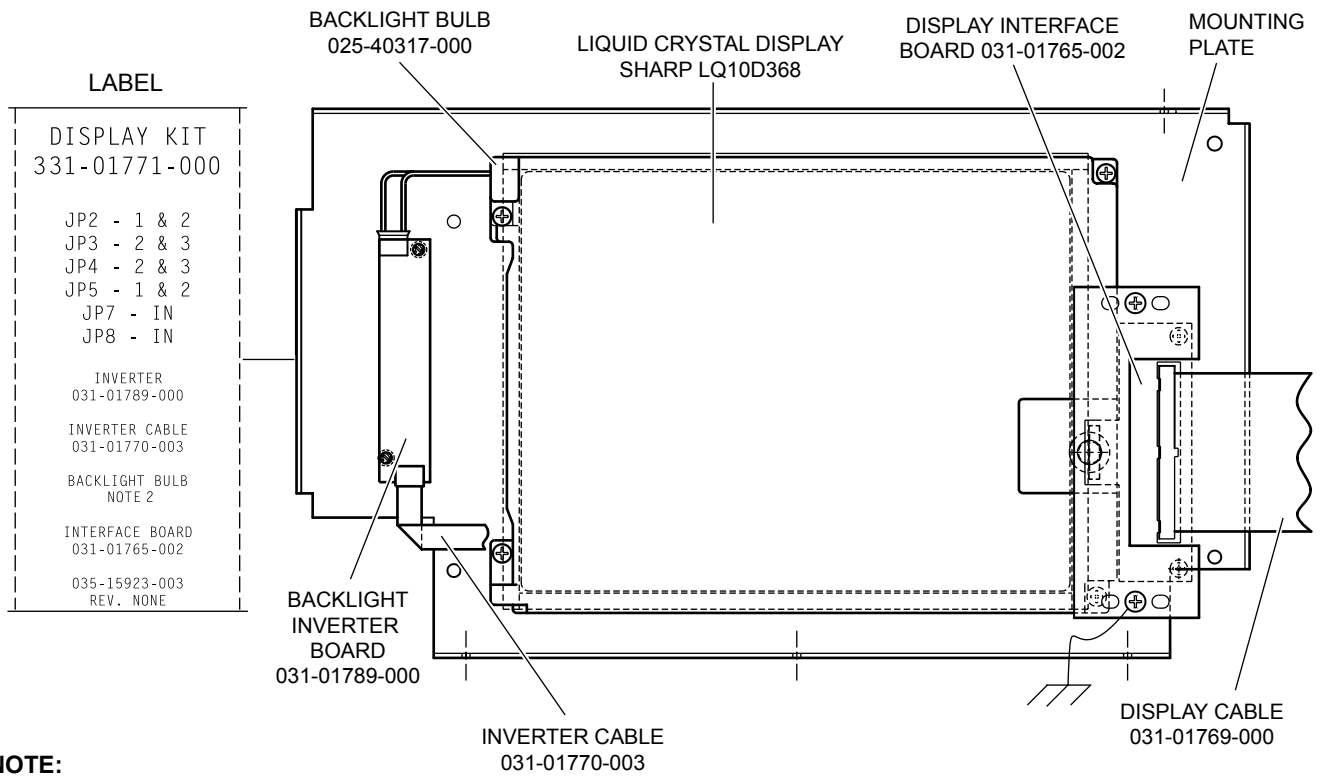

6

NOTE:

1. Configure Microboard Program Jumpers per label.
2. 025-33752-000 (prior to October 2002)
025-40317-000 (after October 2002)

LD05526b

FIGURE 27 - LIQUID CRYSTAL DISPLAY ASSEMBLY – SHARP LQ10D367/368 (031-01774-000) DISPLAY

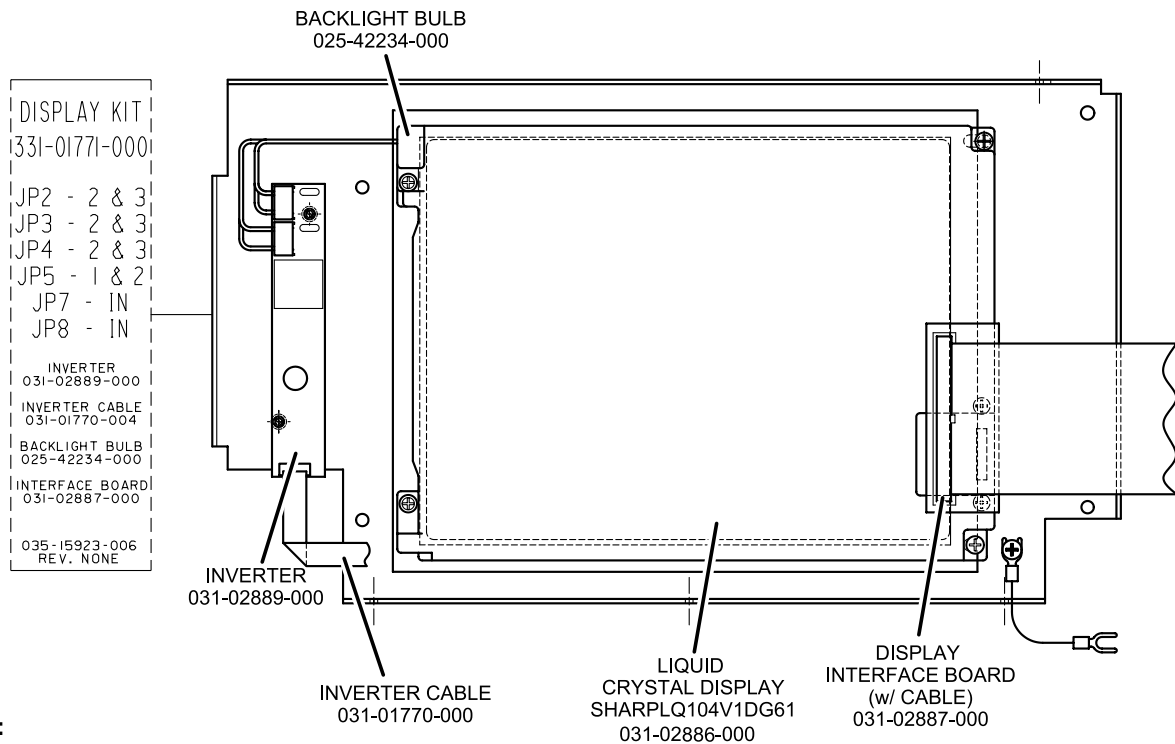

NOTE:

1. Configure Microboard Program Jumpers per label.

LD14074

FIGURE 26 - LIQUID CRYSTAL DISPLAY ASSEMBLY – SHARP LQ104V1DG61 (031-02886-000) DISPLAY

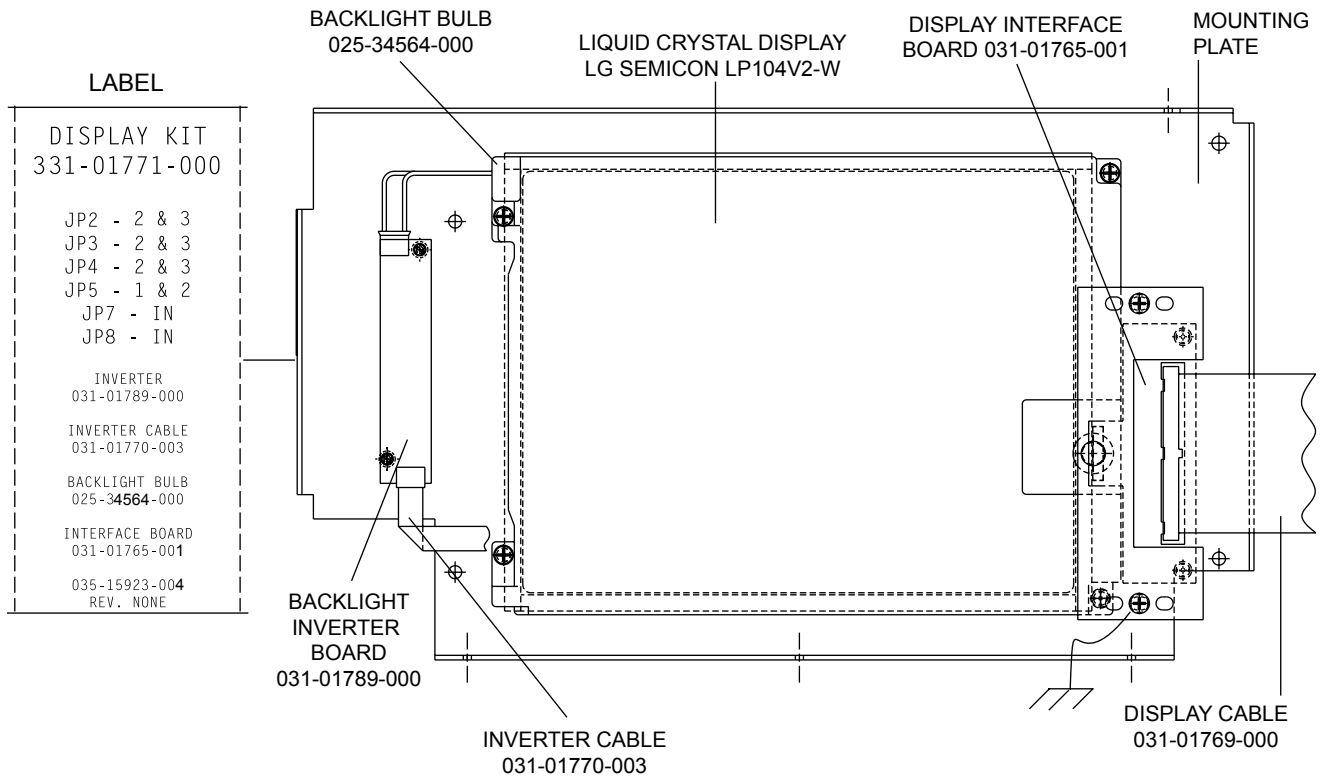

NOTE:

1. Configure Microboard Program Jumpers per label.

LD05525

FIGURE 28 - LIQUID CRYSTAL DISPLAY ASSEMBLY - LG SEMICON LP104V2-W (031-02046-000)

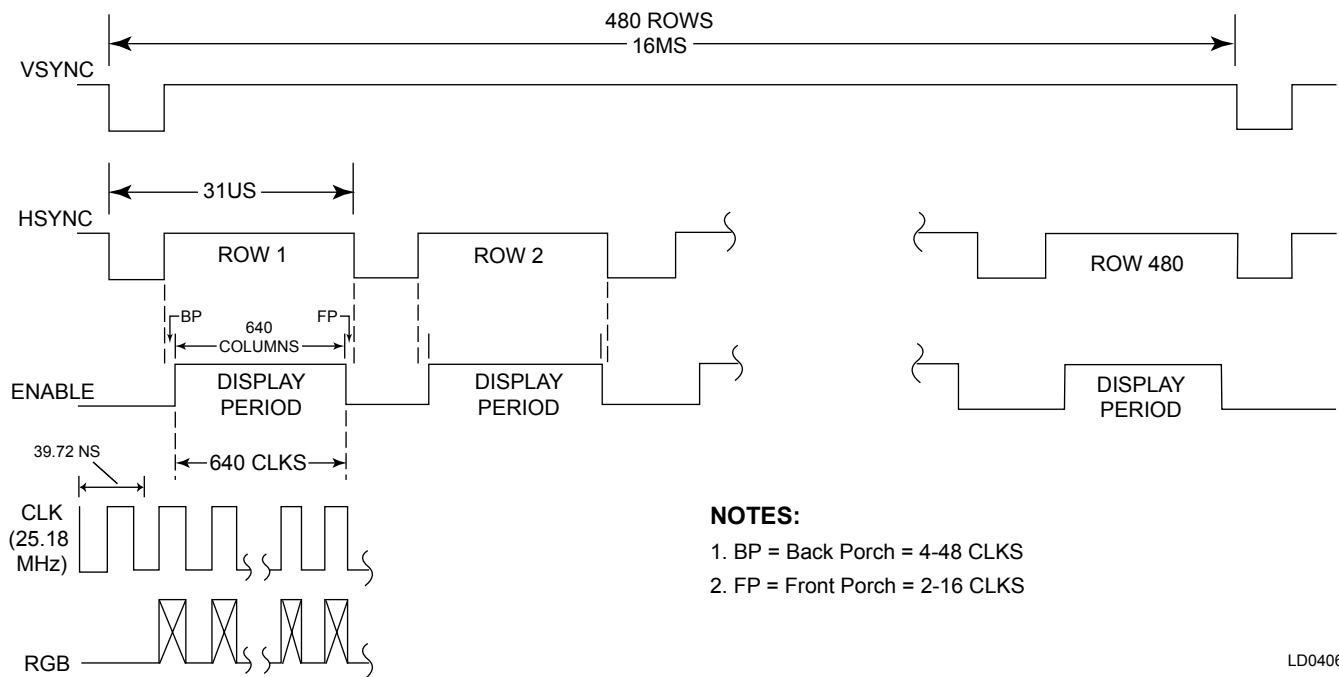

NOTES:

1. BP = Back Porch = 4-48 CLKs
2. FP = Front Porch = 2-16 CLKs

LD04066

FIGURE 29 - LIQUID CRYSTAL DISPLAY TYPICAL CONTROL SIGNAL TIMING

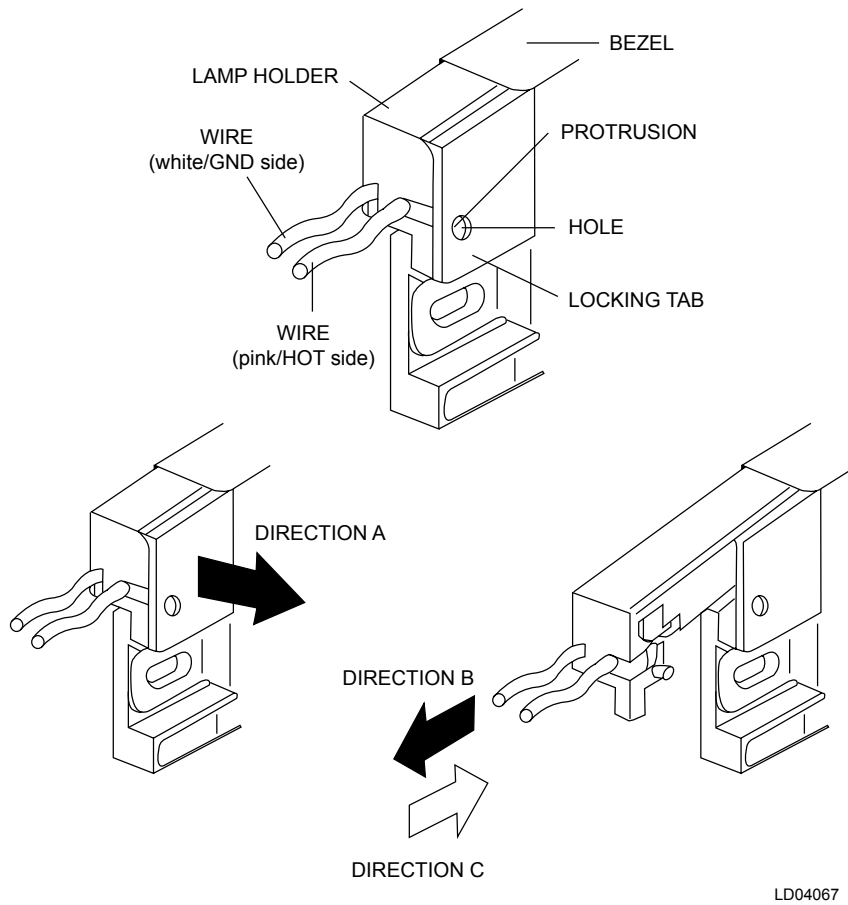

LD04067

FIGURE 30 - DISPLAY (SHARP LQ10D367/368) LAMP REPLACEMENT

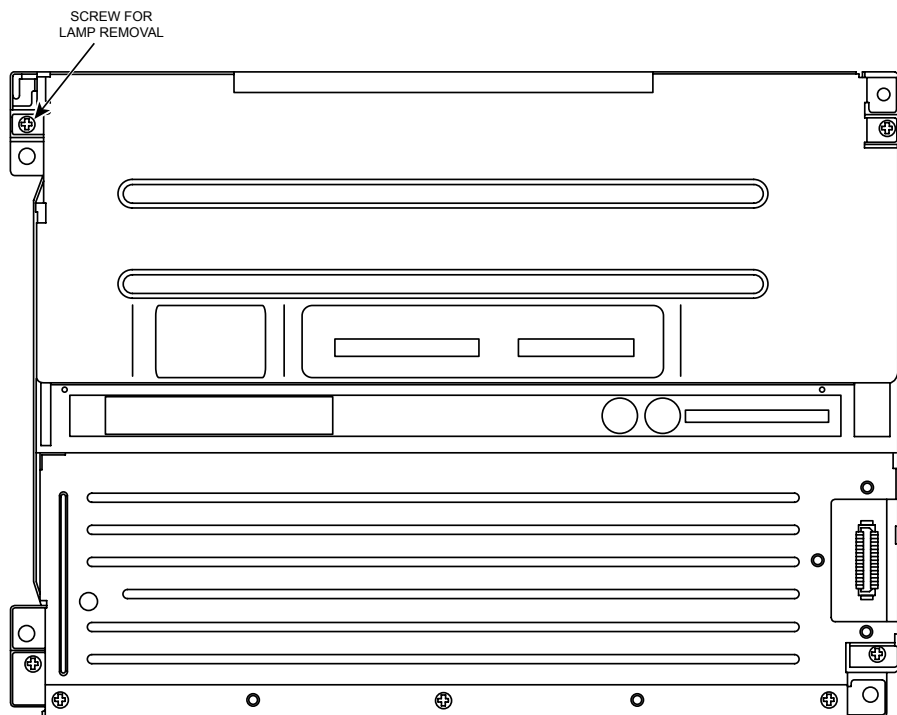

LD14075

FIGURE 31 - DISPLAY (SHARP LQ104V1DG61 (031-02886-000) AND LG LP104V2-W (031-02046-000))

THIS PAGE INTENTIONALLY LEFT BLANK.

SECTION 7 - DISPLAY INTERFACE BOARD

The Display Interface Board is located on the Liquid Crystal Display and is part of the Microboard interface to the Display. It permits the use of Displays by different manufacturers, by providing the Microboard with a means of automatically determining which Display is present.

Since different display manufacturers require different timing and control signals, the Microboard Display Controller must be configured to meet the requirements of the actual display installed. When AC power is applied to the Optiview Control center, the Microboard reads the Panel Identification (PID0 thru PID3) voltage levels on the Display Interface Board during the power-up sequence to determine which display is present. These voltage levels indicate the actual display installed and the Display Controller is automatically configured appropriately. To provide the appropriate Panel ID voltage levels for the different displays, there are different Display Interface Boards. These boards have permanent wire jumpers that provide the voltage levels to the microboard for Panel ID signals (PID0 thru PID3). These jumpers connect these signals to either ground or open-circuit. When connected to ground, the voltage level for that signal is 0VDC. When open, the voltage level is the VCC logic level, which is either 3.3VDC or 5.0VDC, depending on the display (Refer to Microboard Program Jumper JP2).

The following are the different Display Interface Boards and the Panel ID signals they provide to the Microboard:

Display Interface Board 031-01765-001

Display Applicability:

LG Semicon LP104V2-W (031-02046-000)

PID0 – IN (GND)
 PID1 – OUT (VCC)
 PID2 – OUT (VCC)
 PID3 – OUT (VCC)

Display Interface Board 031-01765-002

Display Applicability:

SHARP LQ10D367/368 (031-01774-000)

PID0 – OUT (VCC)
 PID1 – IN (GND)
 PID2 – OUT (VCC)
 PID3 – OUT (VCC)

Display Interface Board 031-02887-000

Display Applicability:

SHARP LQ104V1DG61 (031-02886-000)

PID0 – OUT (VCC)
 PID1 – IN (pin 45 is tied to 44) (GND)
 PID2 – No Connection Open (VCC)
 PID3 – No Connection Open (VCC)

The Displays can operate in either NORMAL or REVERSE mode for the Right/left (R/L) and Up/Down (U/D) scan. Normal for the R/L scan is left to right. Normal for the U/D scan is top to bottom. As used in the Optiview Control Center, it is configured to operate in Normal mode for both of these scans. The Reverse mode for R/L is right to left. Reverse mode for U/D is bottom to top. The Display Interface Board provides the appropriate signals to the display to put it in Normal scan mode. By hardwired jumper or wiring configuration, the signal is either tied to ground, VCC (+3.3VDC or +5VDC, as determined by Microboard Program Jumper JP2) or left open as follows:

Display Interface Board 031-01765-001

Display Applicability:

LG Semicon LP104V2-W (031-02046-000)

P30 – OUT (Open)
 P31 – OUT (Open)

Display Interface Board 031-01765-002

Display Applicability:

SHARP LQ10D367/368 (031-01774-000)

P30 – IN (VCC)
 P31 – IN (GND)

Display Interface Board 031-02887-000

Display Applicability:

SHARP LQ104V1DG61 (031-02886-000)

J1-30 – (VCC)
 J1-31 – (GND)

Display Interface Boards are available individually for service replacement. The part number of the Display Interface Board for the installed display is listed on a label attached to the display mounting plate. The appropriate board is also supplied with display kit 331-01771-000.

The red, green and blue display drive and control signals are simply passed through the **Display Interface Board**. The value of VCC is either +5VDC or +3.3VDC, as determined by the position of Program Jumper JP2 on the microboard.

LD04070

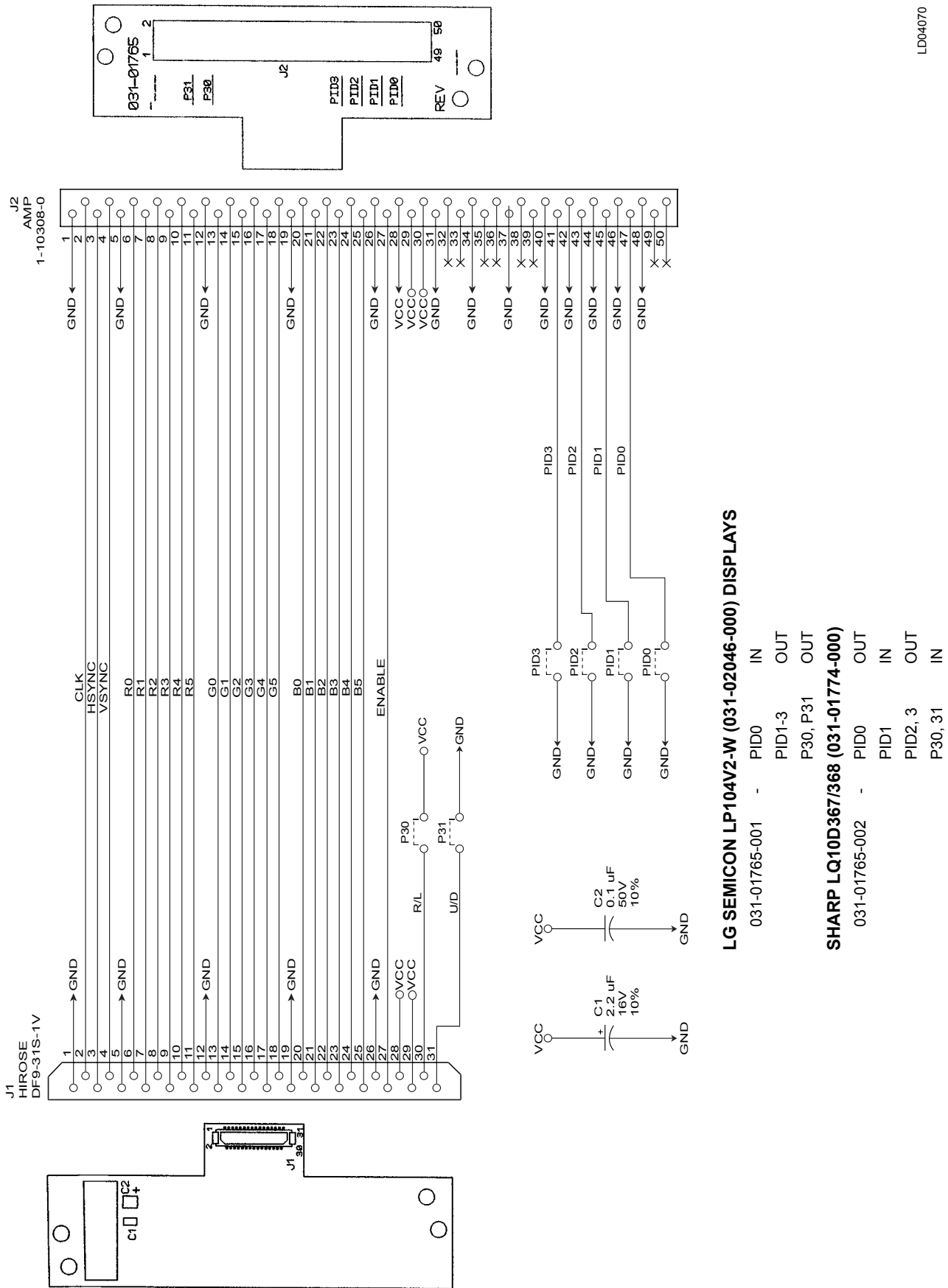

FIGURE 32 - DISPLAY INTERFACE BOARD 031-01765-001 AND 031-01765-002

THIS PAGE INTENTIONALLY LEFT BLANK.

SECTION 8 - DISPLAY BACKLIGHT INVERTER BOARD

The **Display Backlight Inverter Board** generates a high voltage AC signal that is applied to the backlight lamp, causing it to illuminate. The magnitude of the signal determines the lamp brightness. Displays by some manufacturers have two lamps; one at the top and one at the bottom of the display. Other Display manufacturers have only a lamp at the top of the display.

An **Inverter** converts low level DC voltage (+12VDC or +5VDC, as required by the manufacturer) from the Microboard to a 500 to 1500VAC 60K Hz signal that is applied to the lamp. The higher the AC voltage, the greater the brightness of the lamp. When this voltage is not present, the lamp is turned off.



High voltage, up to 1500VAC, is present at the output of the backlight inverter board. Refer to FIGURE 33 to 35 and locate the output connectors. Use extreme caution when working in this area!

Different Display manufacturers require different Backlight Inverter Boards. The different board designs require different control voltage inputs. To accommodate these variations, Microboard Program Jumpers JP3 - JP5, JP7 and JP8 must be configured to provide the required voltage levels. A label attached to the Display mounting plate lists the required Program Jumper configuration for that particular display. Refer to Program Jumper configurations for the various Display applications.

Under Program control, the Microboard generates the control signals that are applied to the Backlight Inverter Board. The Program determines when the lamp is turned on and off. It also adjusts the lamp brightness. To increase the average lamp life of 25000 hours, the lamp brightness is normally adjusted to 50%. This brightness level will still allow the display to be visible. When the Program senses a Keypad key has been pressed, it adjusts the brightness to 100% (maximum).

The lamp illumination high voltage AC is generated from either +12VDC or +5VDC as required by the manufacturer. Microboard Program Jumper JP5 must be positioned to provide the required voltage. The Microboard provides the **Backlight Enable** signal. This signal turns the lamp on and off. Some manufacturers require this signal to be +12VDC, others require +5VDC. Program Jumper JP4 must be positioned to provide the required voltage. Further, some applications require this signal to be a +VDC (+12VDC or +5VDC) to turn on the lamp. Others require this signal to be 0VDC to turn on the lamp. Program Jumper JP3 must be positioned to provide the required polarity.

Depending upon the Display manufacturer, the brightness control input from the Microboard must be either a variable voltage or a variable resistance. Microboard Program Jumpers JP7 and JP8 are used to provide the appropriate technique (Refer to FIGURE 8). The lamp dimmer circuit on the Microboard is an IC that is the electrical equivalent of a 10K ohm potentiometer with 100 positions or steps. The Program adjusts the position of the potentiometer. When configured for variable voltage (JP7 and JP8 installed), the output between Microboard J6-7 and J6-8 is a 0 to +5.0VDC signal. Not all applications require the full 5.0VDC range. If configured for variable resistance (JP7 and JP8 removed), the output between Microboard J6-7 and J6-8 is a 0 to 10K ohm variable resistance.

The OptiView Control Center could be supplied with any of several approved Displays. Each Display requires a specific Backlight Inverter Board as specified below and in FIGURE 33 to 35. These boards are individually available as service replacement parts (the required Backlight Inverter Board part number is listed on the label attached to the Display mounting plate). However, service replacement Displays are provided in a kit (YORK P/N 331-01771-000) that includes the appropriate Backlight Inverter Board (Refer to SECTION 6 - LIQUID CRYSTAL DISPLAY).

SHARP model LQ10D367/368 (031-01774-000) AND LG Semicon LP104V2-W (031-02046-000) displays require a Backlight Inverter Board 031-01789-000 (Refer to *FIGURE 33*).

SHARP model LQ104V1DG61 display (031-02886-000) requires Backlight Inverter Board 031-02889-000 (Refer to *FIGURE 34*). These boards generate a lamp illumination high voltage AC from +12VDC. When the Backlight Enable signal is +5VDC, the high voltage signal is applied to the lamp. When the Enable is 0VDC, the high voltage is removed from the lamp.

The lamp brightness is controlled by a variable voltage signal, developed by the lamp dimmer circuit (Refer to *FIGURE 15*) on the Microboard and applied to the Inverter Board. The lamp dimmer circuit varies the voltage over the range of 0 to +3.0 VDC. 0VDC produces maximum brightness (100%). +3.0VDC produces minimum brightness (0%). Voltages between these values produce a linear brightness between 100% and 0%.

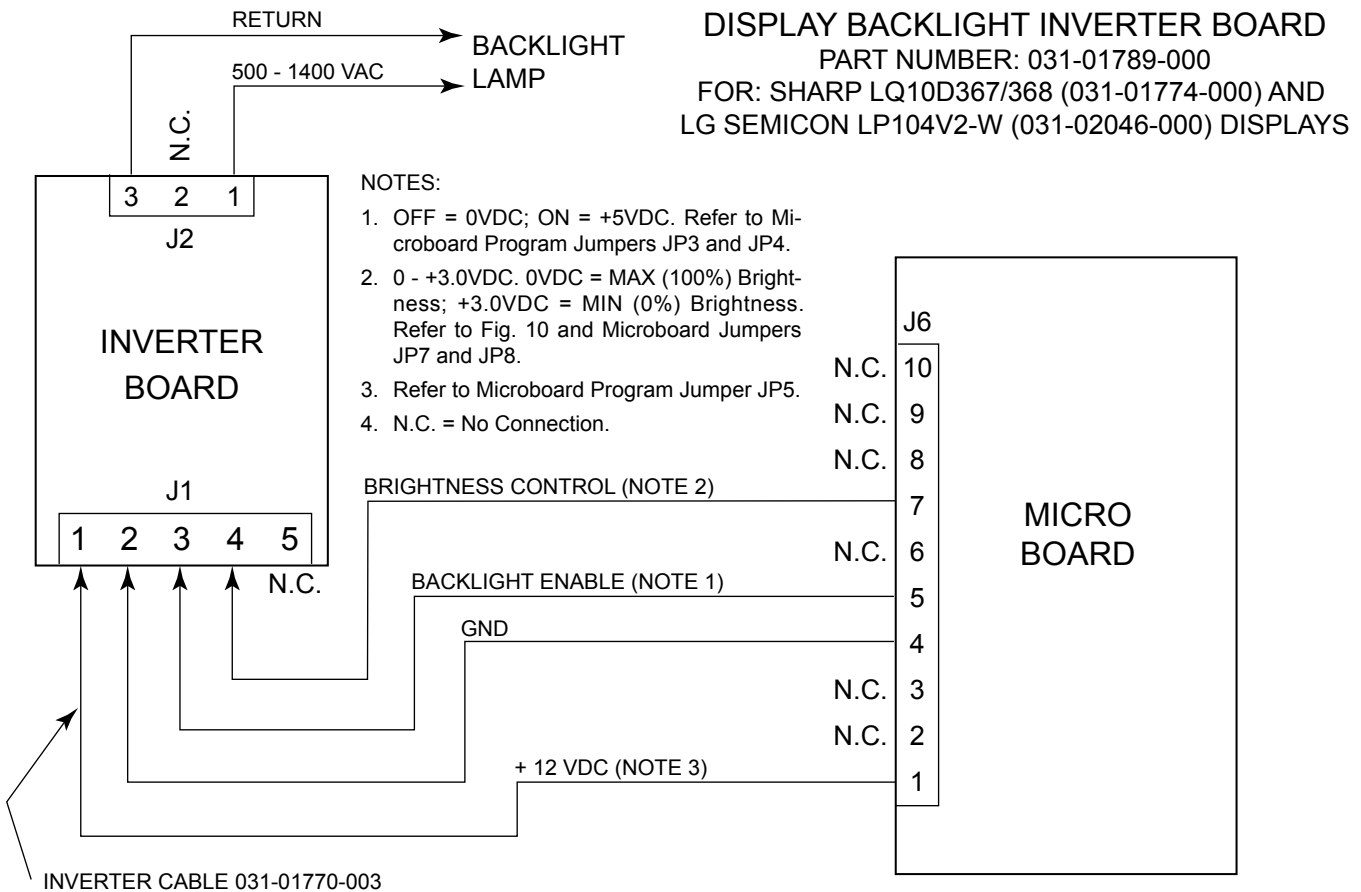
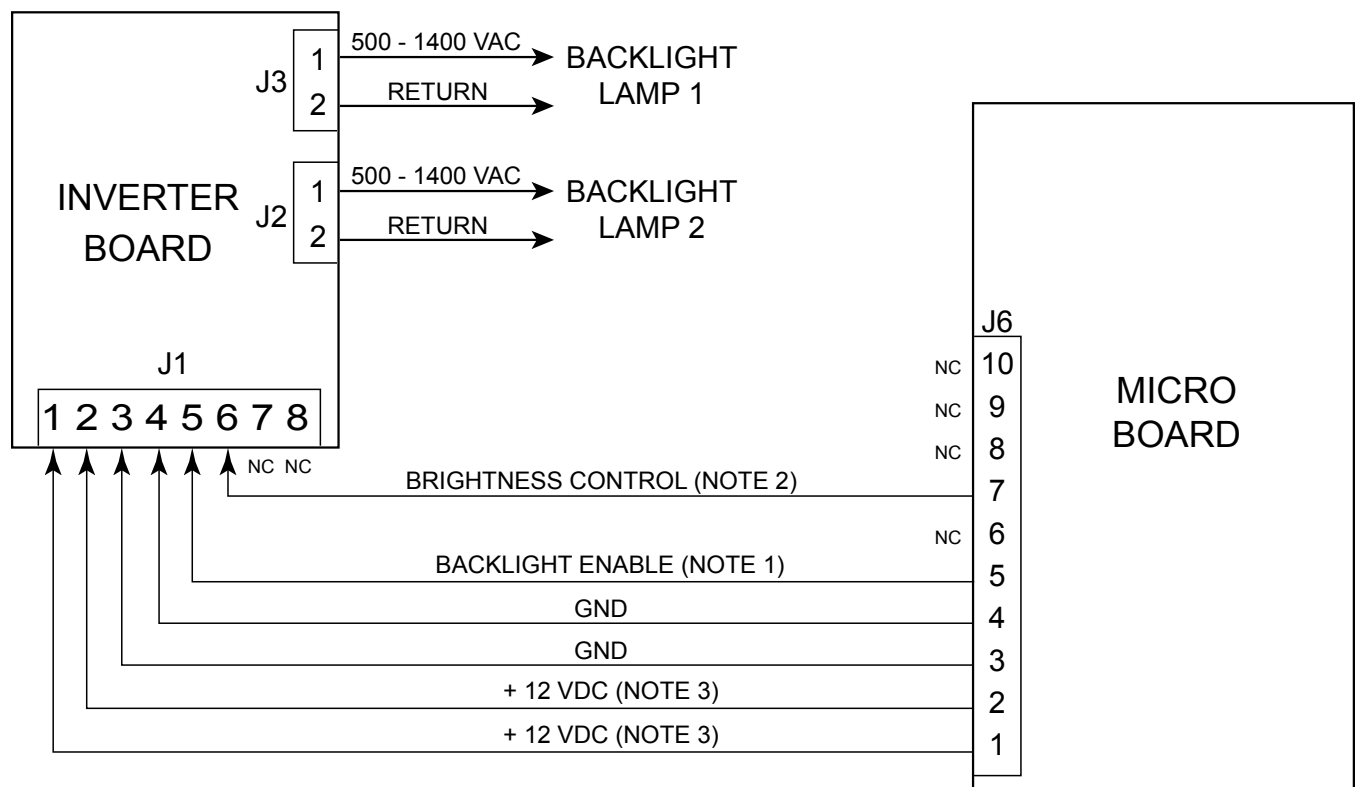

FIGURE 34 - DISPLAY BACKLIGHT INVERTER BOARD (SHARP LQ10D367/368 (031-01774-000) AND LG SEMICON LP104V2-W (031-02046-000))

DISPLAY BACKLIGHT INVERTER BOARD
 PART NUMBER: 031-02889-000
 FOR: SHARP LQ104V1DG6 (031-02886-000) DISPLAYS



8

NOTES:

1. OFF = 0VDC; ON = + 5VDC. Refer to Microboard Program Jumpers JP3 and JP4.
2. 0- + 3.0 VDC. 0VDC = MAX (100%) brightness. +3VDC = MIN (0%) brightness. Refer to Microboard Program Jumpers JP7 and JP8.
3. Refer to Microboard Program Jumper JP5.
4. N.C. = No Connection.

LD09568b

FIGURE 35 - DISPLAY BACKLIGHT INVERTER BOARD - SHARP LQ104V1DG61 DISPLAY 031-02886-000

THIS PAGE INTENTIONALLY LEFT BLANK.

SECTION 9 - KEYPAD

The **Keypad** contains touch-sensitive keys that allow the Operator to interface with the OptiView Control Center. The Operator presses the keys to request the desired screens of information and enter System Setpoints.

The top layer of the Keypad contains embossed areas identifying the keys. Under each embossed key area are two conductors, one on top of the other, separated by an air space. The conductors are arranged in a matrix of rows and columns and connected to the Keypad connector as shown in *FIGURE 36*. The embossed area of each key is located directly over the intersection point of the conductors. Pressing the embossed key area causes contact and electrical continuity between the two conductors. For example, pressing the “1” key creates continuity between the Keypad connector pin 5 (column 3) and pin 13 (row 4). Since this connector is interfaced to the Microboard (J18), the Microboard senses this continuity as described below and concludes the “1” key is pressed.

The Microboard Program continuously scans the Keypad to determine if a key is pressed. Beginning with row 1 and proceeding through all rows, the Program places a LOGIC LOW (<1VDC) on a row, a LOGIC HIGH (>4VDC) on the remaining rows and reads the columns. A logic low in any column indicates a key in that column and row is pressed. For example, if at the

time row 4 is being driven low, if column 3 is low, then the Micro concludes the key at coordinate of row 4 and column 3 is pressed. Since the coordinates of all keys are stored in the Microboard’s Program, it can identify which key is at this coordinate and responds accordingly. In this example the “1” key is pressed.

In order for the Microboard to reliably detect closed and open keys, each key must meet a closed circuit and open circuit resistance requirement. When a key is pressed, the contact resistance must be < 100 Ohms. When a key is not pressed, the contact resistance must be > 1Meg Ohm. If the Microboard is not responding to a pressed key, or if it’s detecting a closed key when none are pressed, it could be because the contact resistance requirements are not being met. The operation of each key can be checked with an Ohmmeter. To check the open and closed contact resistance of any key, refer to *SECTION 20 - DIAGNOSTICS AND TROUBLESHOOTING* of this manual.

The Keypad is attached to the front of the OptiView Control Center door with an adhesive backing. If service replacement is required, start at one corner and slowly peel the Keypad from the door. The rear side of the replacement Keypad is coated with an adhesive covered with a paper backing. Remove the paper backing, align the Display and rocker switch openings and apply the Keypad to the door.

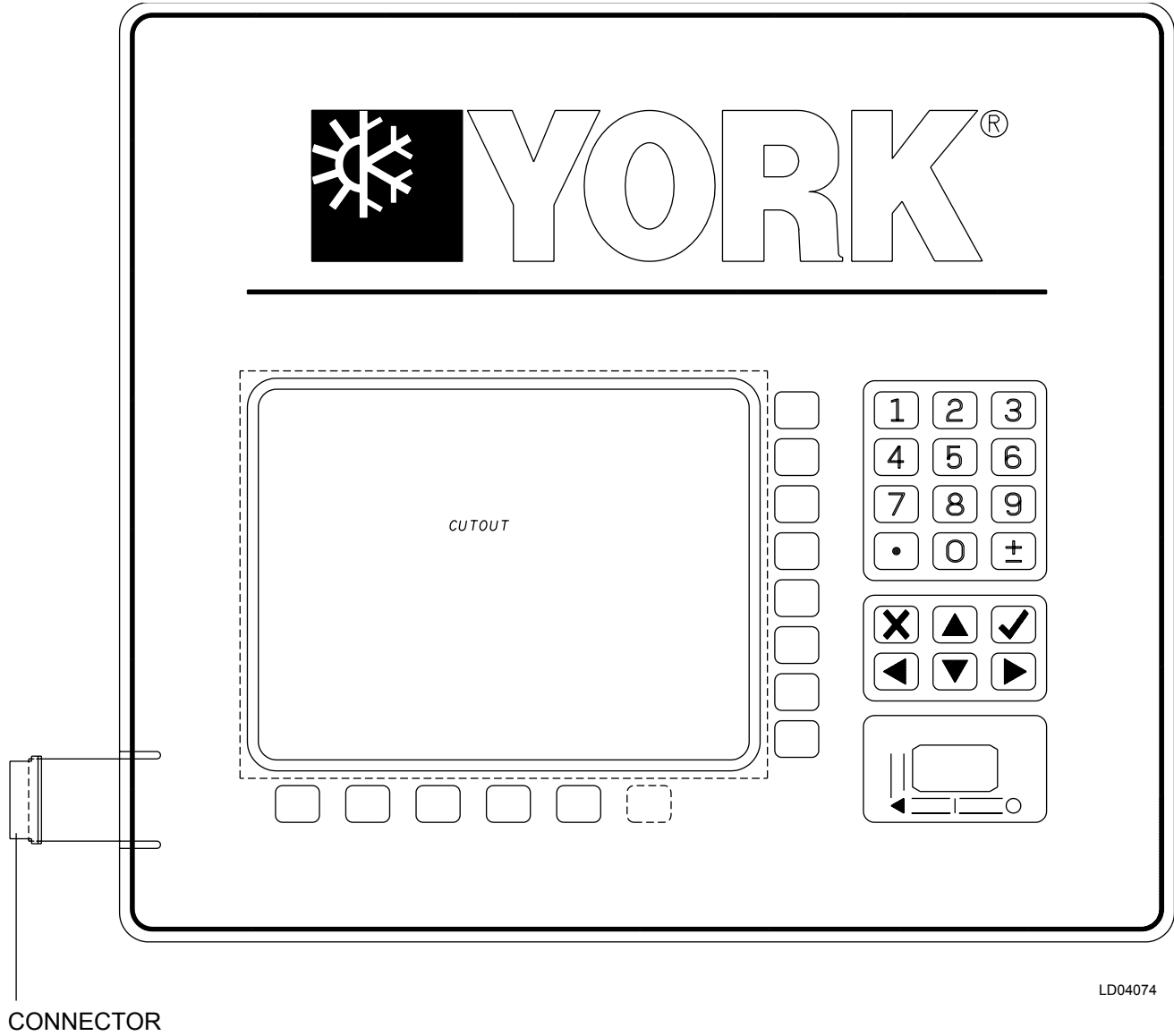
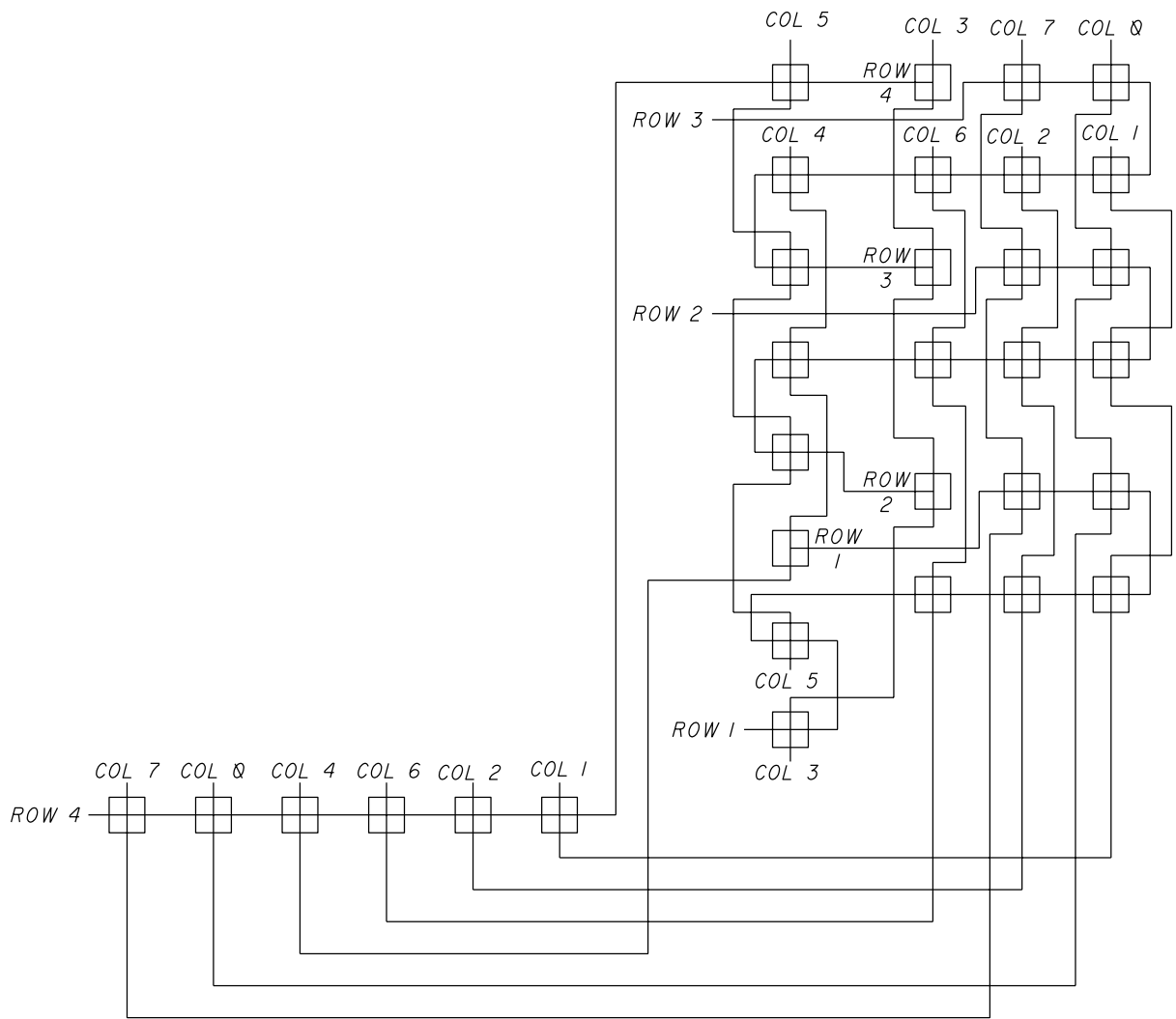
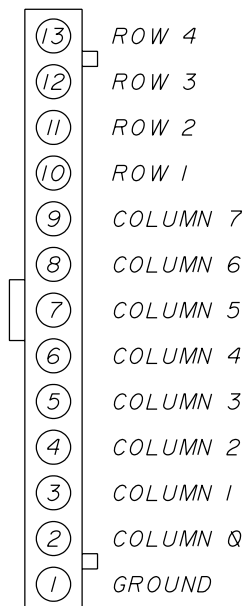

FIGURE 36 - KEYPAD



LD04075



CONNECTOR PIN OUT

LD04076

FIGURE 37 - KEYPAD

THIS PAGE INTENTIONALLY LEFT BLANK.

SECTION 10 - POWER SUPPLY

The Power Supply provides the DC power for the LCD Display and all the printed circuit boards in the OptiView Control Center. It receives a 102 to 132VAC input from an external power source and provides the following DC outputs:

- -12VDC
- +12VDC
- +5VDC
- +24VDC
- Ground

The +24VDC output provides power to the CM-2 Board (Electro-Mechanical starter applications), Solid State Starter Logic Board (Mod “A” Solid State Starter), Solid State Starter Logic/Trigger Board (Mod “B” Solid State Starter) or Adaptive Capacity Control (ACC) (Variable Speed Drive applications). If the Chiller is equipped with Proximity Probe Part number 025-30961-000 or 025-35900-000, the Probe is also powered by this +24VDC.

The -12VDC, +12VDC, Gnd and +5VDC outputs are applied to the Microboard. There, these voltages are applied to the circuits requiring the respective voltage. From the Microboard, the +12VDC and +5VDC are distributed to other system components requiring these voltages. These include the E-Link gateway, Proximity Probe (025-xxxxx-000 only), I/O Board, VSD Oil Pump, LCD Display and Display Backlight Inverter Board. The Condor Power supply allows adjustment of the +5VDC output. To account for losses in wiring and connections and assure sufficient voltage level at the microboard input, the “V Adj” (R51) potentiometer is adjusted to achieve +5.1VDC at the input to the Microboard J1-1.

As shown in *FIGURE 7* (031-01730-000 microboard) and *FIGURE 14* (031-01730-000 microboard), the Microboard contains two voltage regulators that create separate +5VDC and +3.3VDC supplies. The +5VDC supply is dedicated to all the Microboard Analog circuits and is labeled as the +5VDC (Analog) supply. It is also routed to all Pressure Transducers, Temperature

Transmitters, Proximity Probe and Motor controller Board (CM-2, Mod “A” Solid State Starter Logic Board or VSD ACC Board). This permits all Analog circuits to be powered by the same supply, eliminating any offsets caused by voltage regulator drift. Microboard 031-02430-000 has an additional voltage regulator that provides a 2.5VDC power source. The +3.3VDC supply is utilized by the Microprocessor, Flash Memory Card and other digital circuits. It could also be applied to the Backlight Inverter Board, depending on the Display manufacturer’s requirements as explained below.

Different Display manufacturers can require different supply voltages for their display and supporting circuits. To accommodate the different Display manufacturer’s voltage requirements, Microboard Program Jumpers JP2 and JP5 must be positioned to provide the required supply voltages to the Display and the Display Backlight Inverter Board. Either +5VDC or +3.3VDC, as determined by JP2, is applied to the Display. Either +12VDC or +5VDC, as determined by JP5, is applied to the Display Backlight Inverter Board.

The chiller could be equipped with either of two Proximity Probes. The power supply requirements are different for these Probes. All Probes operate from a +5VDC power source. Probe 025-30961-000 and Probe 025-35900-000 require a +24VDC source that is tapped off of the supply to the CM-2 Current Module (Electro-Mechanical Starter applications), Solid State Starter Logic Board (Solid State Starter applications) or ACC Board (VSD applications).



29136A

FIGURE 38 - POWER SUPPLY

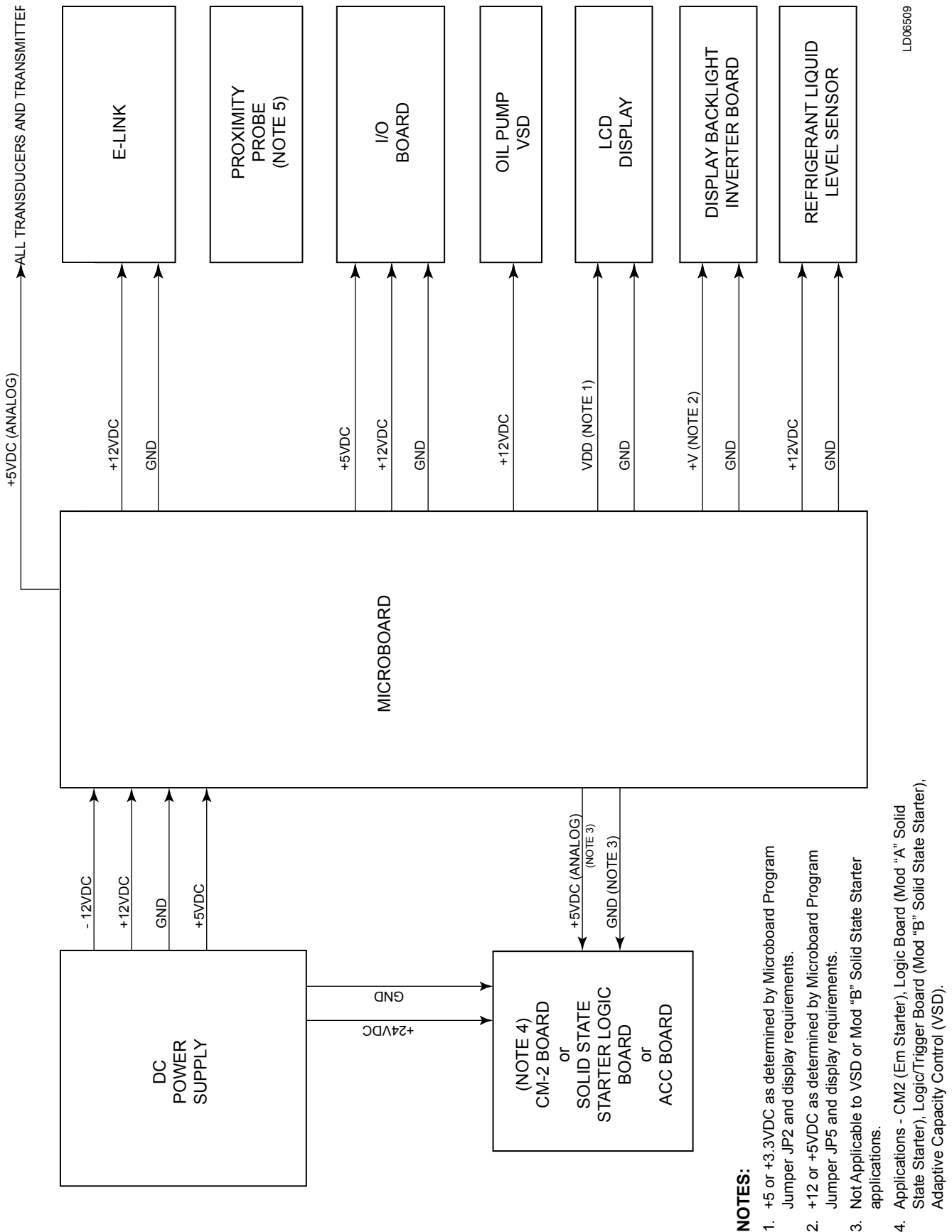

LD06509

FIGURE 39 - POWER SUPPLY – DC POWER DISTRIBUTION (REFER TO OPTIVIEW CONTROL CENTER WIRING DIAGRAM FOR WIRE CONNECTIONS)

SECTION 11 - CURRENT MODULE (CM-2)

On applications where the Compressor Motor is controlled by an Electro-Mechanical Starter, the OptiView Control Center is equipped with a **Current Module**. The Current Module provides compressor motor **Overload** and **Power Fault** protection. The Current Module also provides an analog voltage representing the compressor motor current to the Microboard for display and **Current Limit** control. While the chiller is running, the Microboard controls the Pre-rotation Vane (PRV) position to limit the motor current to the system 100% Full Load Amp (FLA) value.

The contacts of Current Module K1 relay (identified as “CM” contacts on the OptiView Control Center wiring diagram) are interfaced into the Motor Controller initiated shutdown circuit that is located between OptiView Control Center TB6-53 and I/O Board TB1-16 (Refer to *FIGURE 23* and *41*). They are also connected as a digital input to I/O Board J2-1. Relay K1 is normally energized, maintaining its contacts in a closed position. Whenever the Current Module initiates a chiller shutdown, it de-energizes K1, opening its contacts. This interrupts the circuit to I/O Expansion Board RUN relay coil 1R (K18), de-energizing it and causing the Starter to shutdown. Simultaneously, the Microboard reads the opening of these contacts via I/O Board J2-1, initiates a **SYSTEM COASTDOWN** and displays the appropriate message as described below.

Three **Current Transformers** in the Compressor Motor Terminal Box (Refer to *FIGURE 42*) provide 3 phase motor current signals to the **Diode Bridge** (DB). The required turns ratio of the Current Transformers is determined by the system 100% FLA. The Diode Bridge rectifies and combines the three signals into one DC signal that is applied to the parallel **Variable Resistors** (RES). These are Factory adjusted (field adjusted on service replacements) to provide a nominal 1.0VDC (0.15 to 1.10VDC) signal to the Current Module at J1-1 and J1-2 when the compressor motor current is at 100% FLA. *FIGURE 42* contains a formula to calculate the resistance of RES required to achieve 1.0VDC at 100%FLA. The 100% FLA value is located on a label adhered to the inside of the OptiView Control Center door.

The motor current signal input at J1-1 and J1-2 is applied to potentiometer R8. This is Factory adjusted (field adjusted on service replacements) to illuminate the 105% CURR indicator (CR6) when the compressor motor current reaches 105% FLA. This calibrated volt-

age is applied to the **Power Fault** detector, **Overload** detectors and Multiplexer (MUX).

The **Power Fault** circuit protects the compressor motor and driveline from transient torque damage. It anticipates the transient torque condition by detecting a momentary interruption in motor current and de-energizing the starter before damage can occur. If the chiller has been running for greater than 75 seconds and the motor current decreases to less than or equal to 10% FLA, a **Power Fault** shutdown is initiated. The **Power Fault** indicator (CR5) is illuminated and remains illuminated until manually reset with **RESET** switch S2. Relay K1 is de-energized for 1 second and then returned to the energized state. Relay K1 contacts (CM) open for 1 second and then return to the closed state. A **SYSTEM COASTDOWN** is initiated and **POWER FAULT** is displayed on the Display. The chiller will automatically restart upon completion of **SYSTEM COASTDOWN**.

If the motor current remains continuously at greater than or equal to 105% FLA for 50 seconds (Nominal), an **OVERLOAD** shutdown is initiated. The **Overload** indicator (CR4) is illuminated and remains illuminated until manually reset with **RESET** switch S2. Relay K1 is de-energized, opening K1 contacts (CM). Relay K1 remains de-energized until manually reset with **RESET** switch S2. A **SYSTEM COASTDOWN** is initiated and **MOTOR CONTROLLER-CONTACTS OPEN** is displayed. The chiller cannot be started until **RESET** switch S2 is manually pressed.

If the motor current remains continuously at 245% FLA for 40 seconds, 290% FLA for 20 seconds or 360% FLA for 10 seconds, an **OVERLOAD** shutdown is initiated. Relay K1 and **Overload** indicator CR4 operate as described immediately above. A **SYSTEM COASTDOWN** is initiated and **MOTOR CONTROLLER - CONTACTS OPEN** is displayed. The chiller cannot be restarted until **RESET** switch is manually pressed. **LRA/FLA** Potentiometer R16 is factory adjusted (field adjusted on service replacements) to the ratio of Locked Rotor Amps to Full Load Amps. The correct setting is determined by dividing the LRA by the FLA. If Switch S1 is in the “Y-Delta/57%” position, there is no 245% FLA threshold. Switch S1 must be positioned according to the type of Electro-Mechanical starter present; UP for Y-delta or 57% Autotransformer starters, **DOWN** for all other starters.

The Multiplexer (MUX) is an electronic switch with 8 inputs and 1 output. The address applied to it determines the position of the switch (i.e., which input is routed to the output). The inputs to channel 0 through 6 are grounded (0VDC). The input to channel 7 is a 0 to 4.0VDC analog signal, representing motor current over the range of 0 to 100% FLA. It is Factory calibrated by Potentiometer R34 to be 4.0VDC when the compressor motor current is at 100% FLA. Under Program control, the Microboard commands the MUX to route the inputs to the MUX output by applying 3-bit Binary addresses to the MUX address inputs at J5-1,2,3. The voltage level for a logic 1 is +12VDC and logic 0 is 0VDC. The Microboard reads the MUX outputs at J5-6. It first addresses channel 0 to determine the type of starter applied. The 0VDC at channel 0 indicates to the Microboard that this is an Electro-Mechanical Starter application (In all starter applications, the Micro reads channel 0 to determine the type starter applied; 0VDC = EM starter, >0VDC=Solid State Starter). It then addresses channel 7 (ignoring channels 1 through 6) to read the analog motor current voltage. The Microboard interprets this analog value in terms of %FLA and displays it upon operator keypad request. It also uses this value to invoke compressor motor **Current Limit** at 100% FLA and 104% FLA. When motor current rises to 100% FLA, the Microboard prevents any further current rise by inhibiting further Pre-rotation Vanes (PRV) opening until it decreases to 98% FLA. If the motor current continues to rise to 104% FLA, the Microboard applies a close signal to the PRV until the motor current decreases to 102% FLA. While **Current Limit** is in effect, **MOTOR - HIGH CURRENT LIMIT** is displayed.

As detailed in *SECTION 19 - SYSTEM CALIBRATION, SERVICE SETPOINTS AND RESET PROCEDURES* of this manual, to field calibrate Potentiometer R8, the

PRV must be manually operated to achieve 105% FLA compressor motor current. Therefore, during this procedure, **Current Limit** is not invoked until 107% FLA and 110% FLA. The first time the **PRV OPEN** key is pressed on the **COMPRESSOR** Screen after logging in at **SERVICE** access level, a 10 minute window is opened, allowing the current to rise to 107% FLA before further PRV opening is inhibited. This inhibit is released when the current decreases to 106% FLA. If the current continues to rise to 110%, manual control is overridden and a close signal is applied to the PRV until the current decreases to 109% FLA. After 10 minutes, the normal current limit thresholds of 100% FLA and 104% FLA are applied.

The MUX address inputs along with respective outputs are as follows:

TABLE 7 - MUX ADDRESS

BINARY			DECIMAL	OUTPUT
J5-1	J5-2	J5-3		
0	0	0	0	Ground
0	0	1	1	Ground
0	1	0	2	Ground
0	1	1	3	Ground
1	0	0	4	Ground
1	0	1	5	Ground
1	1	0	6	Ground
1	1	1	7	0-5.0VDC motor current analog signal calibrated on CM-2 board to be +4.0VDC at 100% FLA.

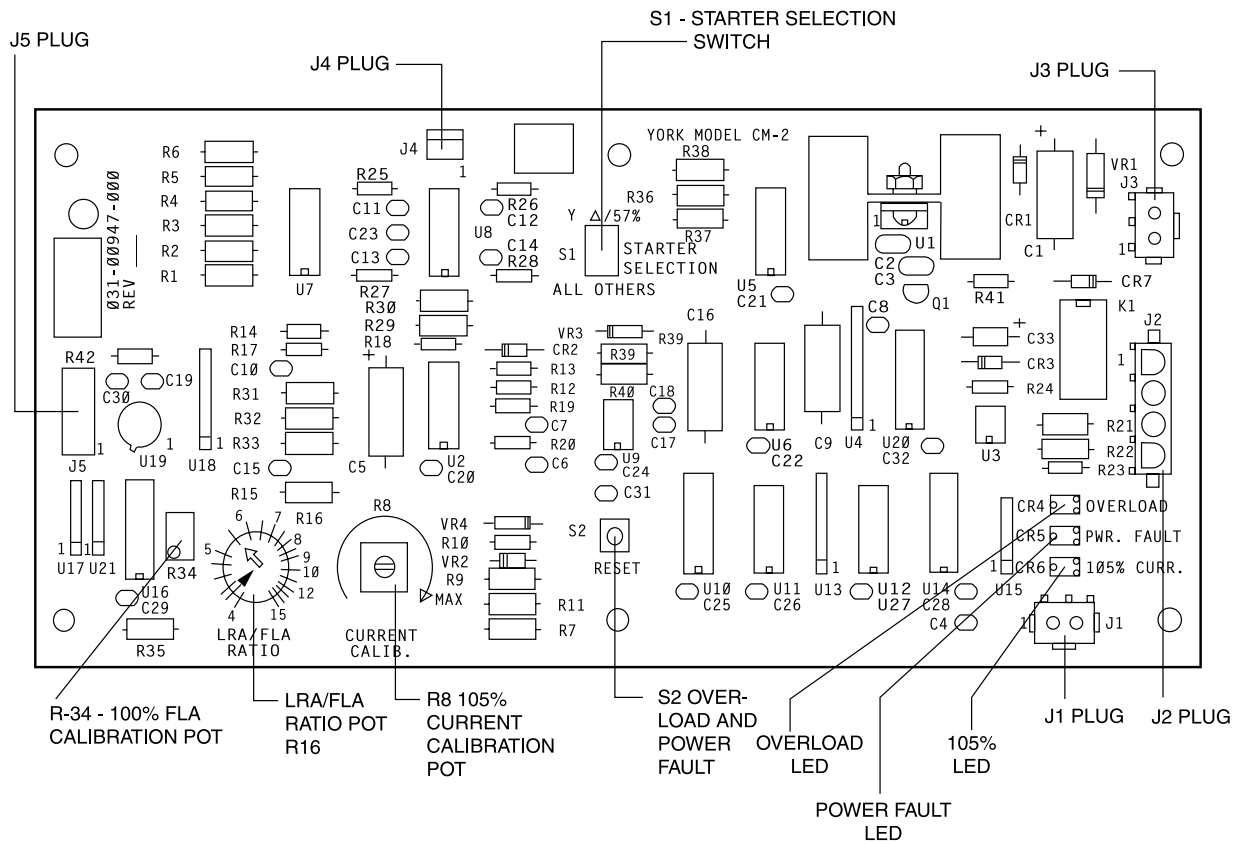

LD04079

FIGURE 40 - CM-2 CURRENT MODULE (ELECTRO-MECHANICAL STARTER APPLICATION)

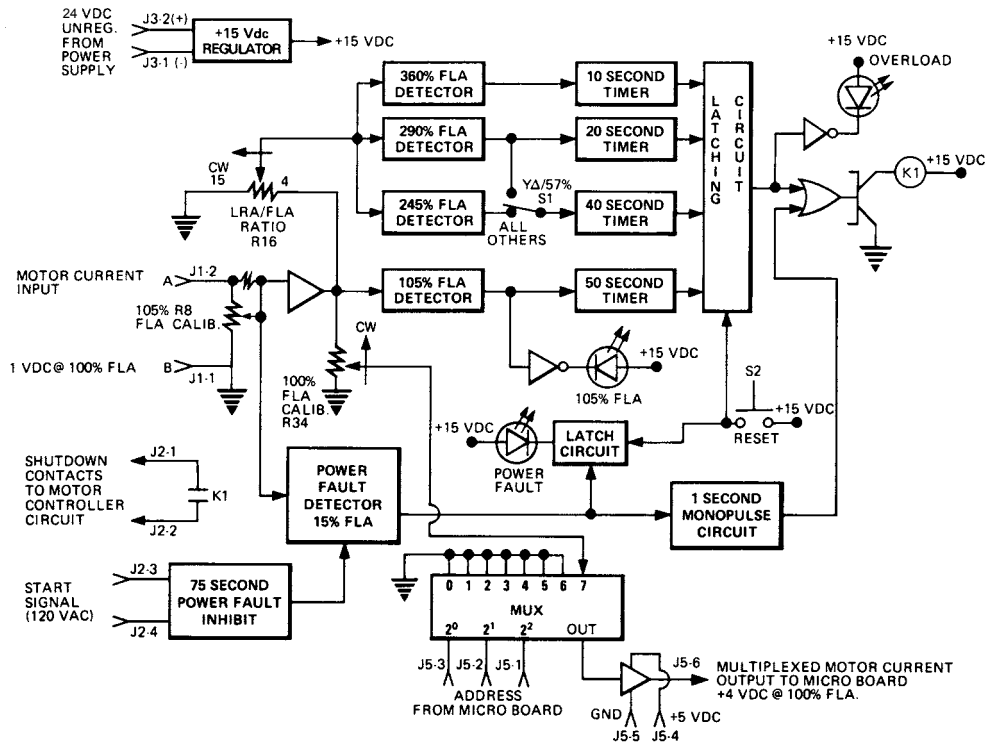

LD04080

FIGURE 41 - CM-2 CURRENT MODULE (ELECTRO-MECHANICAL STARTER APPLICATIONS)

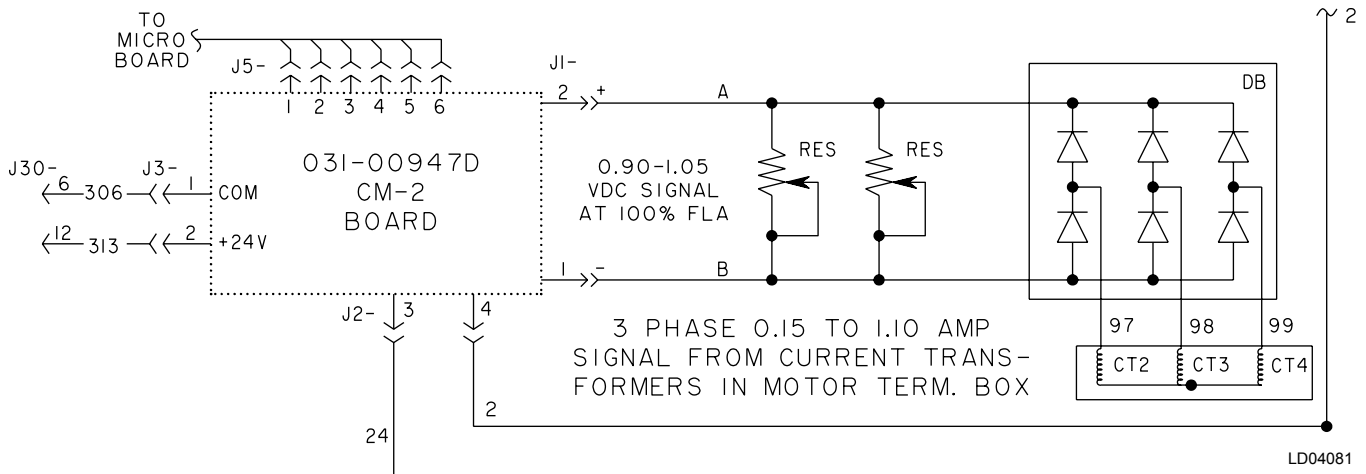

LD04081

MOTOR VOLTAGE	FLA	CT RATIO	RES ^P (OHMS)
208-600	65-111A	200:1	$R = \frac{1.282 \text{ (CT RATIO)}}{\text{FLA}}$
	112-224A	350:1	
	225-829A	700:1	
	830-1790A	1400:1	
2300-4160	11-18C	200:1	$R = \frac{0.247 \text{ (CT RATIO)}}{\text{FLA}}$
	19-37B	200:1	$R = \frac{0.370 \text{ (CT RATIO)}}{\text{FLA}}$
	38-123A	200:1	$R = \frac{0.740 \text{ (CT RATIO)}}{\text{FLA}}$
	124-264A	350:1	
	265-518A	700:1	

NOTES:

- A. Requires passing motor lead through current transformer (CT) once before connecting to power supply.
- B. Requires passing motor lead through CT **twice** before connecting to power supply.
- C. Requires passing motor lead through CT **three** times before connecting to power supply.
- D. Calculates resistance of "RES" to achieve 1.0VDC at FLA.

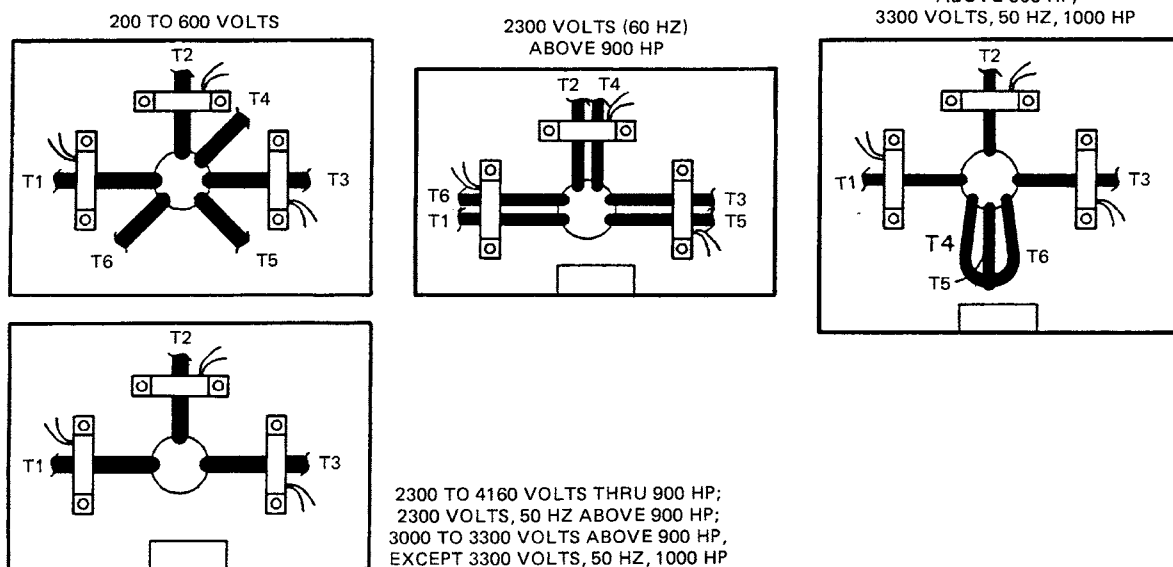

LD04082

FIGURE 42 - CM-2 CURRENT MODULE – INTERFACE, CURRENT TRANSFORMERS AND VARIABLE RESISTORS

SECTION 12 - COMMUNICATIONS

The complete description of the E-Link gateway installation and operation is contained in YORK *Form 450.20-NOM1*.

The E-Link gateway is an optional printed circuit board that provides an interface between the OptiView Control Center and a building control system network. It can be mounted on the upper corner of the left wall of the OptiView Control Center or in its own enclosure in a remote location.

If installed in the OptiView Control Center, the E-Link gateway is powered by +12VDC from the Microboard.

The E-Link gateway communicates with the Microboard COM 4B communications port via an RS-232 interface. As shown in *FIGURE 9*, Microboard Program Jumper JP 27 must be placed on pins 2 and 3 to allow data to be received from the E-Link gateway.

If the remote device that is connected to the E-Link gateway is going to provide remote Start/Stop signals, remote Leaving Chilled Liquid Temperature and/or remote Current Limit Setpoint resets, the Control Source

must be set to BAS on the OPERATIONS Screen. Otherwise, communications will take place in any Control Source mode.

In operation, the Microboard provides chiller pressures, temperatures and status to the E-Link gateway in response to requests from the E-Link gateway. Microboard status LEDs illuminate when the Microboard transmits and receives data on COM 4B. Green LED CR13 (RX4) illuminates when data is being received from the E-Link gateway. Red LED CR12 (TX4) illuminates when data is being transmitted to the E-Link gateway. Similar LEDs on the E-Link gateway annunciate data transfer to/from the Microboard (Refer to *E-Link Gateway Installation Instructions-Part No. 24-10404-9*).

If there is a communications problem between the Microboard and the E-Link gateway, use the LEDs described above to analyze the problem. The COM 4B LoopBack test can be used to verify operation of the Microboard COM 4B communications port. Refer to *SECTION 20 - DIAGNOSTICS AND TROUBLESHOOTING* of this manual.

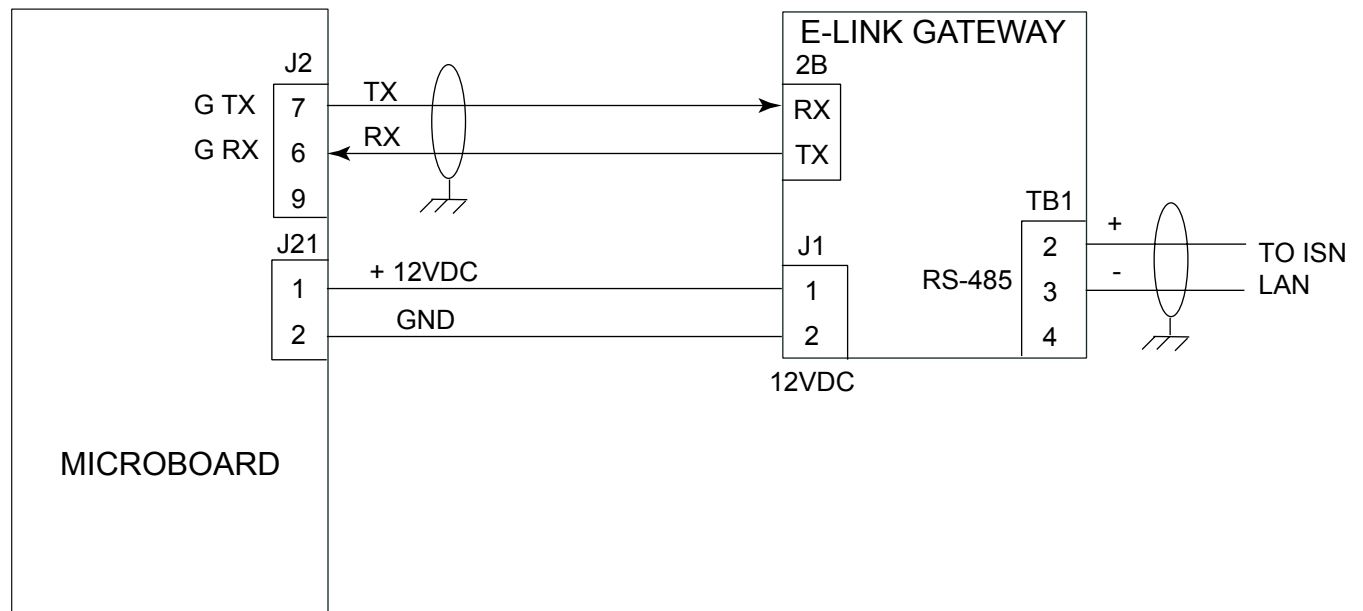

FIGURE 43 - E-LINK GATEWAY INTERFACE BLOCK DIAGRAM

THIS PAGE INTENTIONALLY LEFT BLANK.

SECTION 13 - PRESSURE TRANSDUCERS

System pressures are sensed by the following Pressure Transducers.

- Evaporator
- Condenser
- Compressor shaft oil
- Compressor supply oil
- Compressor oil sump
- Compressor thrust bearing
- Compressor balance piston
- Gear supply oil
- Gear shaft pump oil
- Gear oil cooler D/P
- Compressor oil cooler D/P
- Chilled water entering
- Chilled water leaving
- Condenser water entering
- Condenser water leaving
- Intercooler refrigerant
- Supply air

There are different transducers used to sense these various pressures. The actual transducer used is determined by the required pressure range and refrigerant application. The operation of the various transducers is identical. The difference between them is simply the pressure range over which they operate. Each of the different transducers has a different YORK Part Number.

The transducers output is 4 to 20 mA that is analogous to the pressure applied to the device. These outputs are applied to one of three Frick analog boards, where the mA signal is processed and sent to the microboard via RS-485. The microboard interprets the information as a pressure value in terms of PSIG (pounds per square inch gauge) in English mode or KpaG (Kilo Pascal) in Metric mode. The program converts the transducer output mA to a pressure value with the appropriate formula *FIGURE 44*. The pressures are displayed and used for chiller control and safety shutdowns.

The Evaporator and Condenser pressures are converted to Saturation Temperatures per the appropriate refrigerant pressure/temperature conversion table contained in the Program. These Saturation Temperatures are displayed and used for Chiller control.

The outputs of the Sump and Pump oil Pressure transducers are displayed individually as PSIG values. However, the Supply Oil Pressure is displayed as a

differential value in terms of PSID (pounds per square inch differential in gauge). This PSID value is arrived at by subtracting the Sump Oil Pressure transducer value from the Post Filter Pressure transducer value. During the **System Prelube** period, the outputs of the oil Pressure transducers are compared in a process called **Auto-Zeroing**. The differential between the Sump and Post Filter Pressure Oil Pressure transducer outputs during a 3 second period beginning 10 seconds after the start of the **System Prelube** period are compared to determine the offset between them. During this period, since both of the transducers are sensing the same pressure, their outputs should indicate the same pressure. However, due to accuracy tolerances in transducer design, differences can exist. Therefore, to compensate for differences between transducers and assure differential pressure accuracy, this offset is factored with the actual differential pressure to produce the displayed PSID value. When the oil Pump is turned on following the Auto-zeroing period, the displayed differential value then becomes the actual differential plus or minus the offset that existed during the Auto-Zeroing period. For example, if the Pump transducer indicates 1.0 PSIG greater than the Sump transducer during the Auto-Zeroing period, then 1.0 PSIG will be subtracted from the displayed PSID value while the pump is running. Similarly, if the Pump transducer indicates 1.0 PSIG less than the sump transducer during this period, then 1.0 PSIG would be subtracted from the displayed PSID value while the pump is running. The Auto-zeroing will not be performed if either transducer is out of range.

Each transducers operate from a +12VDC power source. This supply voltage is provided from the Power supply via one of the three Frick analog boards. Each transducer is connected to the Frick board with two wires (plus and minus) as a 4 to 20 mA current loop circuit. +12VDC is supplied to the transducer and the transducer regulates the mA in the loop based on the pressure applied to the transducer. The mA output of each transducer can be measured with a mA meter placed in series with the loop circuit. For example, using the mA formula ($\text{mA} = \text{PSIG} \times .0533 + 4$) the mA output of the Condenser transducer would be 12 mA if the applied pressure to the transducer were 150 PSIG. To convert the mA to a pressure use the pressure formula ($\text{PSIG} = \text{mA} \times 18.75 - 75$). If the pressure or mA is known, the transducer input or output can be predicted with the appropriate pressure formula found in *FIGURE 44*.

0 TO 100 POUND TRANSDUCERS

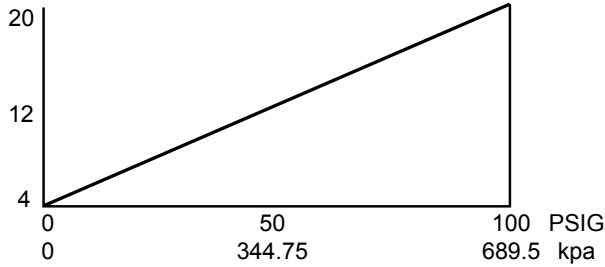

$$mA = P \times .16 + 4$$

$$P = mA \times 6.25 - 25$$

$$mA = kPa \times .0232 + 4$$

$$kPa = mA \times 43.094 - 172.38$$

GEAR SUPPLY OIL PRESSURE
GEAR SHAFT OIL PRESSURE

LD05534a

0 TO 168 WG TRANSDUCERS

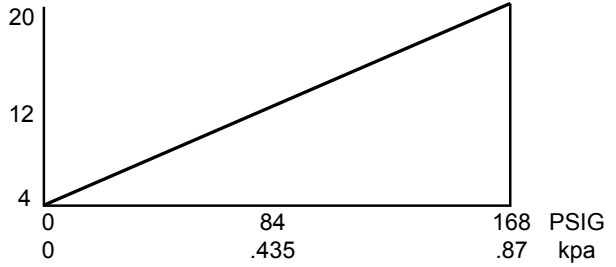

$$mA = P \times .0952 + 4$$

$$P = mA \times 10.5 - 42$$

$$mA = kPa \times 18.416 + 4$$

$$kPa = mA \times .0543 - .216$$

GEAR OIL COOLER D/P
COMPRESSOR OIL COOLER D/P

LD04099a

0 TO 200 POUND TRANSDUCERS

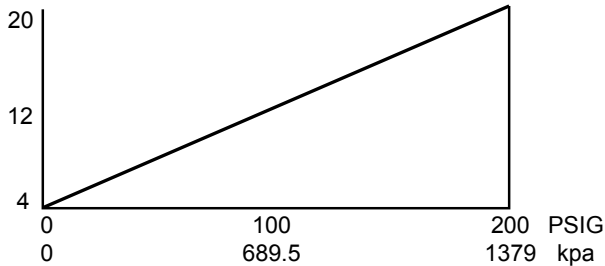

$$mA = P \times .08 + 4$$

$$P = mA \times 12.5 - 50$$

$$mA = (kPa/10) \times .1161 + 4$$

$$kPa = mA \times 86.1875 - 344.75$$

EVAPORATOR PRESSURE
COMPRESSOR SUMP OIL PRESSURE
CHILLED WATER ENTERING PRESSURE
SUPPLY AIR PRESSURE
INTER COOLER REFRIGERANT PRESSURE
COMPRESSOR BALANCE PISTON PRESSURE

LD05535a

0 TO 300 POUND TRANSDUCERS

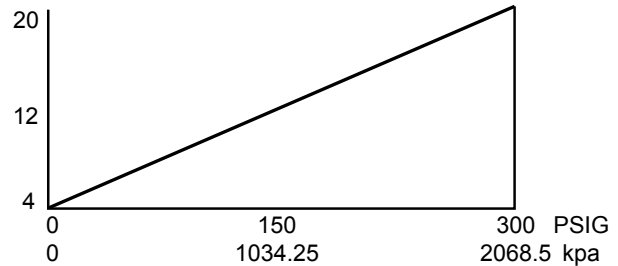

$$mA = P \times .0533 + 4$$

$$P = mA \times 18.75 - 75$$

$$mA = kPa \times .07735 + 4$$

$$kPa = mA \times 129.281 - 517.12$$

COMPRESSOR SHAFT OIL PRESSURE
COMPRESSOR SUPPLY OIL PRESSURE
CONDENSER PRESSURE
COMPRESSOR THRUST BEARING OIL PRESSURE
CONDENSER WATER ENTERING PRESSURE
CONDENSER WATER LEAVING PRESSURE
CHILLED WATER LEAVING PRESSURE

LD05537a

30 TO 130 TEMPERATURE TRANSDUCERS

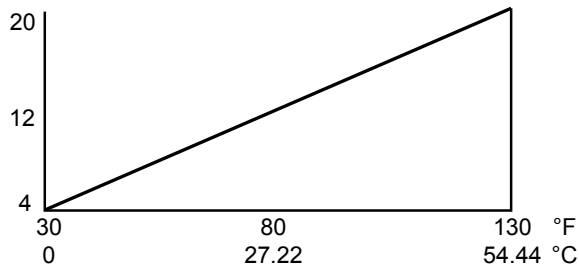

$$mA = ^\circ F \times .16 - .8$$

$$T^\circ F = mA \times 6.25 + 5$$

$$mA = ^\circ C \times .2939 + 4$$

$$^\circ C = mA \times 3.402 - 13.6$$

ENTERING CONDENSER WATER
LEAVING CONDENSER WATER
GEAR OIL COOLER LEAVING WATER
COMPRESSOR OIL COOLER
ENTERING WATER
EVAPORATOR REFRIGERANT LIQUID
CONDENSER REFRIGERANT LIQUID
INTERCOOLER REFRIGERANT LIQUID
SUBCOOLER LIQUID
LEAVING CHILLED WATER
ENTERING CHILLED WATER

LD09969a

30 TO 250 TEMPERATURE TRANSDUCERS

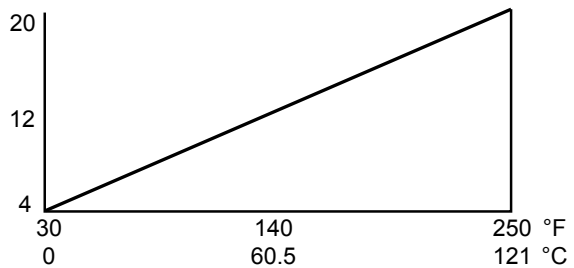

$$mA = ^\circ F \times .0727 + 1.825$$

$$^\circ F = mA \times 13.75 - 25$$

$$mA = ^\circ C \times .1322 + 4$$

$$^\circ C = mA \times 7.5643 - 30.286$$

COMPRESSOR SHAFT END OIL RETURN
COMPRESSOR OIL COOLER LEAVING WATER
GEAR HIGH AND LOW SPEED SHAFT END BEARING
GEAR HIGH AND LOW SPEED BLIND END BEARING
COMPRESSOR THRUST BEARING OIL RETURN
GEAR SUPPLY OIL
COMPRESSOR SUMP OIL
COMPRESSOR DISCHARGE
COMPRESSOR MAIN OIL
MOTOR BLIND BEARING
COMPRESSOR SUCTION
MOTOR SHAFT END BEARING
COMPRESSOR OIL AFTER COOLER

LD09569a

FIGURE 44 - PRESSURE TRANSDUCERS

SECTION 14 - TEMPERATURE TRANSMITTERS

System temperatures are sensed by the following Temperature Transducers.

- Entering condenser liquid
- Leaving condenser liquid
- Gear oil cooler leaving water
- Compressor shaft end oil return
- Compressor oil cooler entering water
- Compressor oil cooler leaving water
- Compressor sump oil
- Leaving chilled liquid
- Entering chilled liquid
- Evaporator refrigerant liquid
- Compressor discharge
- Condenser refrigerant liquid
- Compressor thrust bearing oil return
- Intercooler refrigerant liquid
- Compressor main oil
- Chiller liquid flow
- Gear supply oil
- Condenser liquid flow
- Gear high speed shaft end bearing
- Gear high speed blind end bearing
- Motor shaft end bearing
- Motor blind end bearing
- Suction
- Subcooler liquid
- Gear low speed shaft end bearing
- Gear low speed blind end bearing
- Compressor oil after oil cooler

There are different transducers used to sense these various temperatures. The actual transducer used is determined by the required temperature. The operation of the various transducers is identical. The difference between them is simply the temperature over which they operate. Each of the different transducers has a different YORK Part Number.

The transducers output is 4 to 20 mA that is analogous to the temperature applied to the device. These outputs are applied to one of three Frick analog boards, where the mA signal is processed and sent to the microboard via RS-485. The microboard interprets the information as a temperature value in terms of Fahrenheit (°F) in English mode or Centigrade (°C) in Metric mode. The program converts the transducer output mA to a temperature value with the appropriate formula *FIGURE 44*. The pressures are displayed and used for chiller control and safety shutdowns.

Each transducers operate from a +12VDC power source. This supply voltage is provided from the Power supply via one of the three Frick analog boards. Each transducer is connected to the Frick board with two wires (plus and minus) as a 4 to 20 mA current loop circuit. +12VDC is supplied to the transducer and the transducer regulates the mA in the loop based on the temperature applied to the transducer. The mA output of each transducer can be measured with a mA meter placed in series with the loop circuit. For example, using the mA formula ($\text{mA} = \text{°F} \times .16 - .8$) the mA output of the Condenser Refrigerant temperature transducer would be 12 mA if the applied temperature to the transducer were 80° F. To convert the mA to a temperature use the temperature formula ($\text{PSIG} = \text{mA} \times 6.25 + 4$). If the temperature or mA is known, the transducer input or output can be predicted with the appropriate temperature formula found in *FIGURE 44*.

THIS PAGE INTENTIONALLY LEFT BLANK.

SECTION 15 - REMOTE SETPOINTS

There are three different Remote operating Modes that can be selected at the Keypad: **Analog** Remote mode, **Digital** Remote Mode or **BAS** Remote Mode.

The OptiView Control Center can receive a remote Current Limit and/or a Remote Leaving Chilled Liquid Temperature Setpoint via the following:

Analog Remote Mode

- 0-10VDC Analog Input
- 2-10VDC Analog Input
- 0-20mA Analog Input
- 4-20mA Analog Input

When equipped with software version C.OPT.01.18.307 (or later), software filtering is applied to these inputs. This stabilizes the remote setpoint values under electrical noise conditions and when the inputs are unstable.

Digital Remote Mode

- Pulse width Modulation (PWM) Input

BAS Remote Mode

- RS-232 Serial Port via E-Link gateway

The Analog inputs are connected to the Microboard J22 as shown in *FIGURE 10* and described below. Microboard Program Jumpers JP23 and JP24 must be positioned appropriately to receive either a 0-10VDC, 2-10VDC, 0-20mA or a 4-20mA signal. Refer to Microboard Program Jumpers and explanation below for required configurations.

The PWM inputs are in the form of a 1 to 11 second Relay contact closure that applies 115VAC to the I/O Board TB4-19 (Leaving Chilled Liquid Temp) and TB4-20 (Remote Current Limit) for 1 to 11 seconds. Refer to *FIGURE 20*. The source of 115VAC is I/O Board TB4-1. The PWM input must be received at a frequency of at least once every 30 minutes. If not received within this time interval, the Program assumes the remote device is defective and defaults the Current Limit Setpoint to 100% and the Leaving Chilled Liquid Temperature Setpoint to the locally programmed Local **BASE** value.

The Microboard COM 4B RS-232 Serial Port (J2) receives the Setpoints in serial data form from the E-Link gateway located inside the OptiView Control Center enclosure. The E-Link gateway receives Setpoints from remote external devices and transfers them to the Microboard.

CURRENT LIMIT

REMOTE CURRENT LIMIT SETPOINT with 0-10VDC, 2-10VDC, 0-20mA, 4-20mA or Pulse Width Modulation Signal – The Remote Current Limit setpoint can be reset over the range of 100% to 30% Full Load Amps (FLA) by supplying (by others) a 0-10VDC, 2-10VDC, 0-20mA, 4-20mA or 1 to 11 second Pulse Width Modulated (PWM) signal to the OptiView Control Center. The OptiView Control Center must be configured appropriately to accept the desired signal type as follows:

- The appropriate Remote Mode must be selected: **ANALOG** Remote Mode must be selected when using a voltage or current signal input. **DIGITAL** Remote Mode must be selected when using a **PWM** input.
- If **ANALOG** Remote Mode is selected, the **REMOTE ANALOG INPUT RANGE** setpoint must be set to “0-10VDC” or “2-10VDC” as detailed below, regardless of whether the signal is a voltage or current input signal type.
- Microboard Program Jumper JP23 must be positioned appropriately per the input signal type as detailed below. It is recommended that a qualified Service Technician position this jumper.

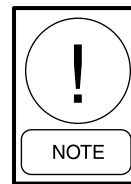

IMPORTANT! - *The signal type used for Remote Current Limit setpoint reset and the signal type used for Remote Leaving Chilled Liquid Temperature setpoint reset must be the same. For example, if a 0-10VDC signal is being used for Remote Leaving Chilled Liquid Temperature Reset, then a 0-10VDC signal must be used for Remote Current Limit Reset.*

0-10VDC

As shown in *FIGURE 10*, connect input to Microboard J22-1 (signal) and J22-5 (Gnd). The setpoint varies linearly from 100% to 30% FLA as the input varies from 0 to 10VDC. This input will only be accepted when **ANALOG** Remote Mode is selected, the **REMOTE ANALOG INPUT RANGE** setpoint is set for “0-10 Volts” and Microboard Program Jumper JP23 has been removed. Calculate the setpoint for various inputs as follows:

$$\text{Setpoint (\%)} = 100 - (\text{VDC} \times 7)$$

For example, if the input is 5VDC, the setpoint would be set to 65% as follows:

$$\begin{aligned} \text{Setpoint (\%)} &= 100 - (5 \times 7) \\ &= 100 - 35 \\ &= 65\% \end{aligned}$$

2-10VDC

As shown in *FIGURE 10*, connect input to Microboard J22-1 (signal) and J22-5 (Gnd). The setpoint varies linearly from 100% to 30% FLA as the input varies from 2 to 10VDC. This input will only be accepted when **ANALOG** Remote Mode is selected, the **REMOTE ANALOG INPUT RANGE** setpoint is set for “2-10 Volts” and Microboard Program Jumper JP23 has been removed. Calculate the setpoint for various inputs as follows:

$$\text{Setpoint (\%)} = 100 - [(\text{VDC} - 2) \times 8.75]$$

For example, if the input is 5VDC, the setpoint would be set to 74% as follows:

$$\begin{aligned} \text{Setpoint (\%)} &= 100 - [(5 - 2) \times 8.75] \\ &= 100 - [3 \times 8.75] \\ &= 100 - 26.25 \\ &= 74\% \end{aligned}$$

0-20mA

As shown in *FIGURE 10*, connect input to Microboard J22-2 (signal) and J22-5 (Gnd). The setpoint varies linearly from 100% to 30% FLA as the input varies from 0mA to 20mA. This input will only be accepted when **ANALOG** remote mode is selected, the **REMOTE ANALOG INPUT RANGE** setpoint is set for “0-10 Volts” and Microboard Program Jumper JP23 has been placed on pins 1 and 2. Calculate the setpoint for various inputs as follows:

$$\text{Setpoint (\%)} = 100 - (\text{mA} \times 3.5)$$

For example, if the input is 8mA, the setpoint would be set to 72% as follows:

$$\begin{aligned} \text{Setpoint (\%)} &= 100 - (8 \times 3.5) \\ &= 100 - 28 \\ &= 72\% \end{aligned}$$

4-20mA

As shown in *FIGURE 10*, connect input to Microboard J22-2 (signal) and J22-5 (Gnd). The setpoint varies linearly from 100% to 30% FLA as the input varies from 4mA to 20mA. This input will only be accepted when **ANALOG** remote mode is selected, the **REMOTE ANALOG INPUT RANGE** setpoint is set for “2-10 Volts” and Microboard Program Jumper JP23 has been placed on pins 1 and 2. Calculate the setpoint for various inputs as follows:

$$\text{Setpoint (\%)} = 100 - [(\text{mA} - 4) \times 4.375]$$

For example, if the input is 8mA, the setpoint would be set to 83% as follows:

$$\begin{aligned} \text{Setpoint (\%)} &= 100 - [(8 - 4) \times 4.375] \\ &= 100 - (4 \times 4.375) \\ &= 100 - 17.5 \\ &= 82.5 \\ &= 83\% \end{aligned}$$

PWM

The Pulse Width Modulation input is in the form of a 1 to 11 second relay contact closure that applies 115VAC to the I/O Board TB4-20 for 1 to 11 seconds. As shown in *FIGURE 20*, connect dry closure relay contacts between I/O Board TB4-20 (signal) and TB4-1 (115Vac). The setpoint varies linearly from 100% to 30% as the relay contact closure time changes from 1 to 11 seconds. The relay contacts should close for 1 to 11 seconds at least once every 30 minutes to maintain the setpoint to the desired value. If a 1 to 11 second closure is not received within 30 minutes of the last closure, the setpoint is defaulted to 100%. A closure is only accepted at rates not to exceed once every 70 seconds. This input will only be accepted in **DIGITAL** remote mode. Calculate the setpoint for various pulse widths as follows:

$$\text{Setpoint (\%)} = 100 - [(\text{pulse width in seconds} - 1) \times 7]$$

For example, if the relay contacts close for 3 seconds, the setpoint would be set to 86% as follows:

$$\begin{aligned}
 \text{Setpoint (\%)} &= 100 - [(3 - 1) \times 7] \\
 &= 100 - (2 \times 7) \\
 &= 100 - 14 \\
 &= 86\%
 \end{aligned}$$

RS-232

As shown in *FIGURE 9*, a setpoint can be received in serial data form at Microboard J2 from the GPIC.

LEAVING CHILLED LIQUID TEMPERATURE**REMOTE LEAVING CHILLED LIQUID TEMPERATURE SETPOINT with 0-10VDC, 2-10VDC, 0-20mA, 4-20mA or Pulse Width Modulation Signal**

Remote Leaving Chilled Liquid Temperature setpoint reset can be accomplished by supplying (by others) a 0-10VDC, 2-10VDC, 0-20mA, 4-20mA or 1 to 11 second Pulse Width Modulated (PWM) signal to the OptiView Control Center. The **LEAVING CHILLED LIQUID TEMPERATURE** setpoint is programmable over the range of 38°F to 70°F (water applications); 36°F to 70°F (water applications with Smart Freeze protection enabled); or 10°F to 70°F (brine applications). The Remote input signal changes the setpoint by creating an offset above the locally programmed Leaving Chilled Liquid Temperature Base setpoint value. The setpoint can be remotely changed over the range of the value programmed for the **REMOTE RESET TEMPERATURE RANGE** setpoint (10, 20, 30, or 40°F with Software version C.OPT.01.18.307 (or later); 10 or 20°F with earlier software versions). For example, if the Local setpoint is 40°F and the **REMOTE RESET TEMPERATURE RANGE** setpoint is programmed for 10°F, the Leaving Chilled Liquid Temperature setpoint can be remotely reset over the range of 40°F to 50°F. The setpoint received through the COM 4B RS-232 serial port is not an offset that is applied to the locally programmed **BASE** value as described above. Rather, it is an actual Setpoint value. The locally programmed value is not used as a **BASE** in this application.

The OptiView Control Center must be configured appropriately to accept the desired signal type as follows:

- The appropriate Remote Mode must be selected: **ANALOG** Remote Mode must be selected when using a voltage or current signal input. **DIGITAL** Remote Mode must be selected when using a PWM input.

- If **ANALOG** Remote Mode is selected, the **REMOTE ANALOG INPUT RANGE** setpoint must be set to “0-10VDC” or “2-10VDC” as detailed below, regardless of whether the signal is a voltage or current signal type.
- Microboard Program Jumper JP24 must be positioned appropriately per the input signal type as detailed below. It is recommended a qualified Service Technician position this jumper.

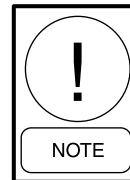

IMPORTANT! - The signal type used for Remote Leaving Chilled Liquid Temperature setpoint reset and the signal type used for Remote Current Limit setpoint reset must be the same. For example, if a 0-10VDC signal is being used for Remote Current Limit setpoint reset, then a 0-10VDC signal must be used for Leaving Chilled Liquid Temperature reset.

0-10VDC

As shown in *FIGURE 10*, connect input to Microboard J22-3 (signal) and J22-5 (Gnd). A 0VDC signal produces a 0°F offset. A 10VDC signal produces the maximum offset above the Local Setpoint value (as allowed by the **REMOTE RESET TEMPERATURE RANGE** setpoint). The setpoint is changed linearly between these extremes as the input varies linearly over the range of 0VDC to 10VDC. This input will only be accepted when **ANALOG** Remote mode is selected, the **REMOTE ANALOG INPUT RANGE** setpoint is set for “0-10VDC” and Microboard Program Jumper JP24 has been removed. Calculate the setpoint for various inputs as follows:

$$\text{Offset (°F)} = \frac{(\text{VDC})(\text{Remote Reset Temp Range})}{10}$$

$$\text{Setpoint (°F)} = \text{Local Setpoint} + \text{Offset}$$

For example, if the input is 5VDC and the Remote Reset Temp Range setpoint is programmed for 10°F and the Local Leaving Chilled Liquid Temperature setpoint is programmed for 40°F, the setpoint would be set to 45°F as follows:

$$\begin{aligned}
 \text{Offset (°F)} &= \frac{5 \times 10}{10} \\
 &= \frac{50}{10} \\
 &= 5^\circ\text{F}
 \end{aligned}$$

$$\begin{aligned}\text{Setpoint} &= 40 + 5 \\ &= 45^{\circ}\text{F}\end{aligned}$$

2-10VDC

As shown in *FIGURE 10*, connect input to Microboard J22-3 (signal) and J2-5 (Gnd). A 2VDC signal produces a 0°F offset. A 10VDC signal produces the maximum allowed offset above the Local Setpoint value (as allowed by the **REMOTE RESET TEMPERATURE RANGE** setpoint). The setpoint is changed linearly between these extremes as the input varies over the range of 2VDC to 10VDC. This input will only be accepted when **ANALOG** remote mode is selected, the **REMOTE ANALOG INPUT RANGE** setpoint is set for “2-10VDC” and the Microboard Program Jumper JP24 has been removed. Calculate the setpoint for various inputs as follows:

$$\text{Offset } (^{\circ}\text{F}) = \frac{(\text{VDC} - 2)(\text{Remote Reset Temp Range})}{8}$$

$$\text{Setpoint } (^{\circ}\text{F}) = \text{Local Setpoint} + \text{Offset}$$

For example, if the input is 5VDC and the Remote Reset Temp Range setpoint is programmed for 10°F and the Local Leaving Chilled Liquid Temperature setpoint is programmed for 40°F, the setpoint would be set to 43.8°F.

$$\begin{aligned}\text{Offset } (^{\circ}\text{F}) &= \frac{(5 - 2)(10)}{8} \\ &= \frac{(3)(10)}{8} \\ &= \frac{30}{8} \\ &= 3.8^{\circ}\text{F}\end{aligned}$$

$$\begin{aligned}\text{Setpoint } (^{\circ}\text{F}) &= 40 + 3.8 \\ &= 43.8^{\circ}\text{F}\end{aligned}$$

0-20mA

As shown in *FIGURE 10*, connect input to Microboard J22-4 (signal) and J22-5 (Gnd). A 0mA signal produces a 0°F offset. A 20mA signal produces the maximum allowed offset above the Local Setpoint value (as allowed by the **REMOTE RESET TEMPERATURE RANGE** setpoint). The setpoint is changed linearly between these extremes as the input varies over the range of 0-20mA. This input will only be accepted when **AN-**

ALOG remote mode is selected, the **REMOTE ANALOG INPUT RANGE** setpoint is set for “0-10VDC” and Microboard Program Jumper J24 has been placed on pins 1 and 2. Calculate the setpoint for various inputs as follows:

$$\text{Offset } (^{\circ}\text{F}) = \frac{(\text{mA})(\text{Remote Reset Temp Range})}{20}$$

$$\text{Setpoint } (^{\circ}\text{F}) = \text{Local Setpoint} + \text{Offset}$$

For example, if the input is 8mA, the Remote Reset Temp Range Setpoint is programmed for 10°F and the Local Leaving Chilled Liquid Temperature setpoint is programmed for 40°F, the setpoint would be set to 44°F as follows:

$$\begin{aligned}\text{Offset } (^{\circ}\text{F}) &= \frac{(8)(10)}{20} \\ &= \frac{80}{20} \\ &= 4^{\circ}\text{F}\end{aligned}$$

$$\begin{aligned}\text{Setpoint } (^{\circ}\text{F}) &= 40 + 4 \\ &= 44^{\circ}\text{F}\end{aligned}$$

4-20mA

As shown in *FIGURE 10*, connect input to Microboard J22-4 (signal) and J22-5 (Gnd). A 4mA signal produces a 0°F offset. A 20mA signal produces the maximum allowed offset above the Local Setpoint value (as allowed by the **REMOTE RESET TEMPERATURE RANGE** setpoint). The setpoint is changed linearly between these extremes as the input varies over the range of 4-20mA. This input will only be accepted when **ANALOG** Remote mode is selected, the **REMOTE ANALOG INPUT RANGE** setpoint is set for “2-10VDC” and Microboard Program Jumper JP24 has been placed on pins 1 and 2. Calculate the setpoint for various inputs as follows:

$$\text{Offset } (^{\circ}\text{F}) = \frac{(\text{mA}-4)(\text{Remote Reset Temp Range})}{16}$$

$$\text{Setpoint } (^{\circ}\text{F}) = \text{Local Setpoint} + \text{Offset}$$

For example, if the input is 8mA, and the Remote Reset Temp Range setpoint is programmed for 10°F and the Local Leaving Chilled Liquid Temperature setpoint is programmed for 40°F, the setpoint would be set to 42.5°F as follows:

$$\begin{aligned}\text{Offset (}^\circ\text{F)} &= \frac{(8-4)(10)}{16} \\ &= \frac{(4)(10)}{16} \\ &= \frac{40}{16} \\ &= 2.5^\circ\text{F} \\ \text{Setpoint (}^\circ\text{F)} &= 40 + 2.5 \\ &= 42.5\end{aligned}$$

PWM

The Pulse Width Modulation input is in the form of a 1 to 11 second relay contact closure that applies 115VAC to the I/O Board TB4-19 for 1 to 11 seconds. As shown in *FIGURE 20*, connect dry closure relay contacts between I/O Board TB4-19 (input) and TB4-1 (115VAC). A contact closure time (pulse width) of 1 second produces a 0°F offset. An 11 second closure produces the maximum allowed offset above the Local Setpoint value (as allowed by the **REMOTE RESET TEMPERATURE RANGE** setpoint). The relay contacts should close for 1 to 11 seconds at least once every 30 minutes to maintain the setpoint to the desired value. If a 1 to 11 second closure is not received within 30 minutes of the last closure, the setpoint is defaulted to the Local setpoint value. A closure is only accepted at rates not to exceed once every 70 seconds. This input will only be accepted in **DIGITAL** Remote mode. Calculate the setpoint for various pulse widths as follows:

$$\text{Offset (}^\circ\text{F)} = \frac{(\text{pulse width in seconds} - 1)(\text{Remote Reset Temp Range})}{10}$$

$$\text{Setpoint (F}^\circ) = \text{Local Setpoint} + \text{Offset}$$

For example, if the relay contacts close for 5 seconds and the Remote Reset Temp Range setpoint is programmed to 10°F and the Local Leaving Chilled Liquid Temperature setpoint is programmed for 40°F, the setpoint would be set to 44°F as follows:

$$\begin{aligned}\text{Offset (}^\circ\text{F)} &= \frac{(5 - 1)(10)}{10} \\ &= \frac{(4)(10)}{10} \\ &= \frac{40}{10} \\ &= 4^\circ\text{F}\end{aligned}$$

$$\begin{aligned}\text{Setpoint (}^\circ\text{F)} &= 40 + 4 \\ &= 44^\circ\text{F}\end{aligned}$$

RS-232

As shown in *FIGURE 9*, a Setpoint can be received in serial data form at the Microboard COM 4B serial port (J2) from the E-Link gateway.

THIS PAGE INTENTIONALLY LEFT BLANK.

SECTION 16 - HOT GAS BYPASS

With the optional Hot Gas Bypass feature, the Control Center modulates a valve located in the Hot Gas Bypass connection between the condenser and the evaporator to control the flow of gas to the evaporator. The valve is modulated in response to load and surging conditions.

The Hot Gas Bypass Screen accessed from the **COMPRESSOR** Screen displays the present operation of the hot gas valve. A service technician can manually operate the hot gas valve from this screen. Adjustments to the hot gas setpoints as well as manual operation can also be made by navigating to the **CAPACITY** Screen.

The Microboard controls the Hot Gas Valve by sending a position command over the COM3 RS-484 serial communication link to the Frick Analog board number 1 that is mounted inside the control center. The board converts the command into the appropriate pneumatic signal to control the valve. The valve position is displayed on the Hot Gas Screen as well as the Capacity Screen as 0% (closed) to 100% (fully open).

A Potentiometer mounted on the Pre-rotation vanes provides PRV position for this feature, as explained later in this section. It is displayed on the Hot Gas Bypass Screen as 0% (closed) to 100% (fully open).

The Evaporator and Condenser pressure transducers provide these pressure values to the Microboard. The Microboard uses these values to calculate the **DELTA P/P** parameter as follows: [(condenser pressure minus evaporator pressure) divided by evaporator pressure]. Although this parameter is not used in the Hot Gas Control, it represents compressor **HEAD** and is displayed on the Hot Gas Bypass Screen for reference only.

OPERATION

The hot gas bypass valve is used primarily at low loads to maintain a suction gas flow required by the compressor for stability. When the compressor has reduced capacity to a minimum flow via pre-rotation vane throttling, further capacity reductions are accomplished by opening the hot gas bypass valve. This maintains the flow to the compressor by bypassing the discharge gas back to the compressor suction.

However, the hot gas flow replaces the useful evaporation in the cooler since the compressor flow is at a minimum. Thus, the net chilling capacity is reduced (albeit not efficiently)

The minimum suction flow or minimum compressor PRV position will vary. As the differential **HEAD** pressure is lowered (due to colder condenser water) the compressor is capable of the stable operation at lower loads. The programming in the chiller software thus used the differential **HEAD** pressure to establish when the hot gas may be needed.

This valve is open a shutdown to allow the condenser pressure to equalize with the evaporator quickly, thus reducing backflow of high pressure gas through the compressor to the evaporator.

The hot gas valve is a pneumatic control valve with a positioner. The control signal from the control panel is 4 to 20 mA (milli amp) DC, which is converted to 3 to 15 PSIG / 0.2-1.0 bar pneumatic signal by an I/P transducer. The valve will be fully open at 4 mA DC, fully closed at 20 mA DC.

THIS PAGE INTENTIONALLY LEFT BLANK.

SECTION 17 - SURGE PROTECTION

As the differential HEAD pressure falls, the compressor is capable of stable operation with less refrigerant gas flow (lower minimum compressor pre-rotation vane positions). From an energy standpoint, it is wise to use the compressor pre-rotation vanes for capacity control rather than how gas bypass whenever pos-

sible. The Anti-surge output to the High Selector Relay (HSR) provides a minimum closure of the pre-rotation vanes to suit the measured HEAD pressure input. (view the Capacity Control Screen) This output also provides one of the inputs signals for the hot gas valve control to use in calculating the hot gas valve.

THIS PAGE INTENTIONALLY LEFT BLANK.

SECTION 18 - SYSTEM CALIBRATION, SERVICE SETPOINTS AND RESET PROCEDURES

The chiller is supplied from the YORK Factory with all factory mounted components fully calibrated. The following procedures are used to verify these calibrations or calibrate a component after it has been field replaced.

Most of the following procedures require the Service Technician to be logged in at SERVICE Access Level (Access Code 1 3 8 0). However, others require the ADMIN (Administration) Access Level. The ADMIN Password changes daily and is valid for 1 calendar day only. This password is obtained by contacting the local Johnson Controls Service Center. When requesting this password, supply the CONTROLS version of software (available on the DIAGNOSTIC Screen) and the calendar day on which you intend to use it.

Programmable Service Setpoints are used by the Program to control critical chiller operation. Also, some of these Setpoints can be used to enable or disable certain features. Although they have been entered at the YORK Factory, they can be changed by a field Service Technician. If the BRAM battery backed memory device is field replaced, all of the programmed setpoints will be lost. They will have to be re-entered into the new BRAM. Each of these Setpoints is described below. In general, the following procedure is used to enter Setpoints in this section:

1. Log in with the appropriate access level
2. Select the appropriate Display Screen.
3. Press the desired Setpoint key.

A dialog box appears, giving the minimum and maximum allowed values, Default value and present value. The dialog box can be canceled at any time by pressing the CANCEL (X) key.

4. If the dialog box begins with the word ENTER, use the numeric keys to enter the desired value. Leading zeroes are not necessary. Press the • key to place a decimal point at the appropriate place. Pressing the ✓ key displays the Default value. Pressing the ✓ key clears the entry. The ◀ key is a backspace key and causes the entry point to move back one space. If the dialog box begins with SELECT or ENABLE, use the ◀ and ▶ keys to select the desired value. The ◀ key decreases the value, and the ▶ key increases the value.

5. Press the ENTER (✓) key. If the value is within range, it is accepted and the dialog box disappears. The chiller will begin to operate based on the new value. If out of range, the value is not accepted and a message describing why it is not acceptable is displayed momentarily.

Some Safety shutdowns will not permit the chiller to start until a special reset procedure is performed. These reset procedures require SERVICE access level and should not be performed by anyone other than a Service Technician. Each of these procedures is described below.

ELECTRO-MECHANICAL STARTER APPLICATIONS

If the Compressor Motor is driven by an Electro-Mechanical Starter, the OptiView Control Center is equipped with a CM-2 Current Module along with supporting components Diode Bridge (DB) and Calibration Resistors (RES), as described in a previous chapter of this manual. The following procedures can be used to verify the calibration and perform the calibration if necessary. In addition to the calibration, Switch S1 and Potentiometer R16 have to be set appropriately on the CM-2 Module. If the CM-2 and/or RES are field replaced, field calibration is necessary.

CM-2 Settings

1. Place Switch S1 in the appropriate position per the Starter type:
 - UP: Y-Delta or 57% Auto-transformer Starter
 - DOWN: All others
2. Calculate LRA/FLA ratio by dividing the Motor Lock Rotor Amps by the chiller Full Load Amps ($LRA/FLA = \text{ratio}$) and then adjust Potentiometer R16 to the ratio value.

Calibration Verification

1. At the Keypad, log in at SERVICE access level using access code 1 3 8 0.
2. Select MOTOR Screen and set Current Limit and Pulldown Demand Limit Setpoints to 100% FLA.

3. Run chiller. Read compressor motor current in Phase A, B, and C using a clamp-on Ammeter. Apply ammeter to highest Phase.
4. Select COMPRESSOR Screen.
5. Manually operate the Pre-rotation Vanes by pressing the OPEN and CLOSE Keys as required to achieve a motor current equivalent to 100% FLA as indicated by the clamp-on Ammeter. The motor current value on the Display should indicate 100% FLA.
6. Manually operate the Pre-rotation Vanes by pressing the OPEN and CLOSE keys as required to achieve a motor current equivalent to 105% FLA as indicated by the clamp-on Ammeter. The 105% LED on the CM-2 Module should illuminate.

If the calibration verification does not perform as above, the following Calibration procedure will have to be performed:

Calibration

1. At the Keypad, log in at SERVICE access level using access code 1 3 8 0.
2. Select MOTOR Screen and set Current Limit and Pulldown Demand Limit Setpoints to 100% FLA.
3. Select COMPRESSOR Screen.
4. Run chiller and read compressor motor current in Phase A, B and C using a clamp-on Ammeter. Apply Ammeter to highest Phase.
5. Manually operate the Pre-rotation Vanes by pressing the OPEN and CLOSE Keypad keys as required to achieve a motor current equivalent to 100% FLA as indicated by the clamp-on Ammeter. The voltage across Variable Resistors (RES) should be 0.90 to 1.05VDC. Measure this voltage by connecting a Voltmeter at CM-2 Board J1-2 (+) to J1-1(-). If necessary, adjust RES to achieve this value. *FIGURE 42* contains formulas to calculate the resistance of RES required to achieve this voltage. Adjust both resistors equally such that the combined resistance equals the calculated value.
6. Manually operate the Pre-rotation Vanes by pressing the OPEN, CLOSE and HOLD Keypad keys, as required, to achieve a motor current equivalent to 105% FLA as indicated by the clamp-on Ammeter. Loosen locking nut on Potentiometer R8 on CM-2 and adjust until the CM-2 Module 105% LED illuminates.

Counterclockwise increases signal level; Clockwise decreases signal level. Tighten locking nut.

7. Manually operate the Pre-rotation Vanes by pressing the OPEN and CLOSE Keypad keys, as required, to achieve a motor current equivalent to 100% FLA as indicated by the clamp-on Ammeter. Loosen locking nut on Potentiometer R34 on CM-2 and adjust until the motor current value on the Display indicates 100% FLA. Clockwise increases the signal level; Counterclockwise decreases the signal level. Tighten locking nut.

REFRIGERANT LEVEL CONTROL

This is an option that only applies if the chiller to has a Level Control Valve installed.

If enabled the refrigerant Level Control operation can be view by navigating to the Condenser Screen and selecting Refrigerant Level Control.

To enable or disable and enter control values the OptiView panel must be in Service Mode

Enabled and Disable under General Option screen

1. Start at the Home Screen
2. Setup
3. Options
4. Change Setpoint
5. ▼ key till Green box is at Subcooler Level
6. Press ENTER
7. Use ◀ and ▶ keys to Enable/Disable
8. Press ENTER

Level Control Valve Start Position can be set by navigating to Miscellaneous Setpoints Screen

1. Start at the Home Screen
2. Setup
3. Setpoint
4. Miscellaneous Setpoints
5. Change Setpoints
6. ▼ key till Green box is at Level Control Valve Start Position
7. Press ENTER
8. Enter the new value (0% to 100% Default 100%)
9. Press ENTER

Subcooler Level can be set by navigating to the Capacity Control Screen

1. Start at the Home Screen
2. Capacity Control
3. PID Tuning
4. Select PID till Subcooler is displayed
5. Change Setpoint

A green box will appear over the SP value

6. ▼ key to move Green Box to another value

SP (setpoint) P (proportional) I (integral) D (Derivate)

P-I-D Set the speed at which the valve will move to control setpoint

There are two PID's routines one for Zone-1 and one for Zone-2

RR Ramp time (1 to 10 minutes Default 3 minutes)

The ramp time will begin counting at the end of the "Pulldown Time Remaining".

During the ramp time the level control valve will move from its start position to control position.

SP sets the level setpoint (0% to 100% Default 44%)

7. Press ENTER
8. Enter the new value for SP, Zone-1 PID, Zone-2 PID, RR if required.
9. Press ENTER

Level Control Valve Pulldown Delay time can be set by navigating to the Time Setpoints screen

1. Start at the Home Screen
2. Setup
3. Setpoints
4. Time Setpoints
5. Change Setpoints
6. ▼ key till Green Box is at Level Control Valve Pulldown Delay
7. Press ENTER
8. Enter new value (0 to 15 minutes Default 10)
9. Press ENTER

The I/P that delivers pneumatic air to the Level Control valve must be set for direct action.

4 mA = 0 PSIG

20 mA = 15 PSIG

0% = 20 mA = Full Closed

100% = 4 mA = Full Open

Effective Setpoint

Displays the valve setpoint position as it moves from its startup position to control position during the "Ramp Time Remaining".

Zone Transition Delta Programmed from the Subcooler Screen

1% to 20% Default 10%

Sets the value in percent the PID will switch from Zone-1 operation and Zone-2 operation. If the current refrigerant level is greater than the Zone Transition Delta then Zone-2 PID will be in control. If the current refrigerant level is less than the Zone Transition Delta then Zone-1 PID will be in control.

Zone Transition Time Programmed from the Subcooler Screen

1 to 60 Seconds Default 10 seconds

Sets the time delay for transition from Zone-1 to Zone-2 and Zone-2 to Zone-1.

Manual Control

1. Start at the Home Screen
2. Capacity Control
3. Auto/Manual
4. Capacity Control
- Press until SUBCOOL is displayed
5. Switch to Manual

Three new boxes appear

Raise - to open the Level Control Valve

Lower – to close the Level Control Valve

Set – to enter a percent (%) value

If the MANUAL percent value is ever more than +/- 5 percent of the Auto percent the transfer back to AUTO will be inhibited, the LED will illuminate and the SWITCH TO AUTO will be RED.

To switch back to AUTO change the manual value to within 5 percent.

Standby Lubrication

To maintain oil seal integrity while the chiller is shut-down, a feature can be enabled that turns on the oil pump for 1 to 5 minute duration every 1 to 24 hour interval if the chiller or oil pump has not been run in the 1 to 24 hours depending on the interval setpoint time.

To enable or disable and enter time values the OptiView panel must be in Service Mode

To Enable or Disable Standby Lube

1. Start at the Home screen
2. Compressor
3. Oil pump
4. Standby Lube
5. Enter
6. Use ◀ and ▶ keys
7. Enter/Disable
8. Press ENTER

To enter time Duration and Interval

1. Start at the Home Screen
2. Setup
3. Setpoints
4. Time Setpoints
5. Page Down
6. Change Setpoints
7. ▼ key till Green Box is at Standby Lube Duration
8. Press ENTER
9. Enter new value 1 to 5 minutes Default 3 minutes
10. Press ENTER
11. ▼ key till Green Box is at Standby Lube Interval
12. Press ENTER
13. Enter new valve X to X hours Default X
14. Press ENTER

HOT GAS BYPASS CONTROL

This is an option that only applies if the chiller has a Hot Gas valve installed.

If enabled the hot gas valve operation can be view by navigating to the Compressor Screen and selecting Hot Gas.

To enable or disable and enter control values the OptiView panel must be in Service Mode.

Enable/Disable

1. Start at the Home Screen
2. Setup
3. Options
4. Change Setpoint
5. ▼ key till Green Box is at HOT GAS
6. Press ENTER
7. Use ◀ and ▶ keys
8. Enter/Disable
9. Press ENTER

To Enter Control Values

1. Start at the Home Screen
2. Capacity Control
3. PID Tuning
4. Select CONTROL
5. Press until "HGV" is displayed
6. Select PID
7. Press until the TEMPERATURE is displayed
8. Change Setpoint
9. A green box will appear over the SP value
10. ▼ key to move Green Box to another value
11. SP (setpoint) P (proportional) I (integral) D (Derivate)
12. P-I-D sets the speed at which the hot gas valve moves
13. SP sets the leaving chilled liquid setpoint temperature
14. Press ENTER
15. Enter new value
16. Press ENTER

Manual Control

1. Start at the Home Screen
2. Capacity Control
3. Auto/Manual
4. Capacity Control

Press until HOT GAS is displayed

5. Switch to Manual

Three new boxes appear

Raise - to open the hot gas valve

Lower – to close the hot gas valve

Set – to enter a percent (%) value

If the MANUAL percent value is ever more than +/- 5 percent of the Auto percent the transfer back to AUTO will be inhibited, the LED will illuminate and the SWITCH TO AUTO will be RED.

To switch back to AUTO change the manual value to within 5 percent.

INTERSTAGE VALVE A OR B

This is an option that only applies if the chiller has one or two OptiView controllable Interstage Valves installed.

If enabled the interstage valve operation can be view by navigating to the Compressor Screen and selecting Interstage Valve A or B.

To enable or disable and enter control values the OptiView panel must be in Service Mode.

Enable/Disable

1. Start at the Home Screen
2. Setup
3. Options
4. Change Setpoint
5. ▼ key till Green Box is at COMPRESSOR STAGES
6. Press ENTER
7. Enter the number of compressor stages 2 or 3-Press ENTER

8. ▼ key till Green Box is at INTERSTAGE VALVES
9. Press ENTER
10. Enter the number of interstage valves 1 or 2
11. Press ENTER

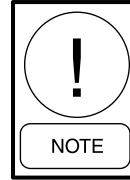

Two stage compressors can have one interstage valve

Three stage compressors can have one or two interstage valves

To Enter Control Values

1. Start at the Home Screen
2. Capacity Control
3. PID Tuning
4. Select PID
 - Press until the INTERSTAGE is displayed
5. Change Setpoint
 - A green box will appear over the SP value
6. ◀ and ▶ keys for “A” or “B” interstage valve
7. ▼ key to move Green Box to another value
 - SP (setpoint) P (proportional) I (integral) D (Derivate)
 - P-I-D sets the speed at which the interstage valve moves
 - SP sets the pressure differential setpoint
 - SPRR sets ramp rate in percent per second
8. Press ENTER
9. Enter new value
10. Press ENTER

Manual Control

1. Start at the Home Screen
2. Capacity Control
3. Auto/Manual
4. Capacity Control
 - Press until INTERSTAGE A or B is displayed

5. Switch to Manual

Three new boxes appear

Raise - to open the hot gas valve

Lower – to close the hot gas valve

Set – to enter a percent (%) value

If the MANUAL percent value is ever more than +/- 5 percent of the Auto percent the transfer back to AUTO will be inhibited, the LED will illuminate and the SWITCH TO AUTO will be RED.

To switch back to AUTO change the manual value to within 5 percent.

VANE CONTROL

The OptiView panel must be in Service Mode to enter control values.

To Enter Control Values

1. Start at the Home Screen
2. Capacity Control
3. PID Tuning
4. Select CONTROL

Press until VANE is displayed

5. Select PID

Press until the TEMPERATURE is displayed

Only three control points are involved with the Vane

Temperature

Suction (See note *)

Discharge (See note #)

6. Change Setpoint

A green box will appear over the SP value

7. ▼ key to move Green Box to another value

SP (setpoint) P (proportional) I (integral) D (Derivate)

SPRR

P-I-D sets the speed at which the vane will move

SP sets the leaving chilled liquid setpoint temperature

SPRR ramp rate in degrees per second of change to achieve setpoint

8. Press ENTER
9. Enter new value
10. Press ENTER

* Suction PID is for controlling override. When the suction pressure reaches the SP (setpoint) the vane will begin to close at the PID values (PID values are the values in the P-I-D boxes)

Discharge PID is for controlling override. When the discharge pressure reaches the SP (setpoint) the vane will begin to close at the PID values (PID values are the values in the P-I-D boxes)

Manual Control

1. Start at the Home Screen
2. Capacity Control
3. Auto/Manual
4. Capacity Control

Press until VANE is displayed

5. Switch to Manual

Three new boxes appear

Raise - to open the hot gas valve

Lower – to close the hot gas valve

Set – to enter a percent (%) value

If the MANUAL percent value is ever more than +/- 5 percent of the Auto percent the transfer back to AUTO will be inhibited, the LED will illuminate and the SWITCH TO AUTO will be RED.

To switch back to AUTO change the manual value to within 5 percent.

DEMAND CONTROL

The OptiView panel must be in Service Mode to enter control values.

To Enter Control Values

1. Start at the Home Screen
2. Capacity Control
3. PID Tuning

4. Select PID

Press until DEMAND is displayed

5. Change Setpoint

A green box will appear over the SP value

6. ▼ key to move Green Box to another value

SP (setpoint) P (proportional) I (integral) D (Derivate)

SPRR+ and SPRR-

P-I-D sets the speed at which the vane will move

SP sets the current limit of the chiller motor

SPRR+ ramp rate per second the current will be permitted to increase

SPRR- ramp rate per second the current will be permitted to decrease

7. Press ENTER

8. Enter new value

9. Press ENTER

CHILLER STARTS AND OPERATION HOURS RESET

The Number of Starts and the Operating Hours can be reset to zero or preset to a desired number. However, this should never be arbitrarily performed. Use the following procedure:

1. At the keypad, login at ADMIN access level. This password changes daily. Contact your local Johnson Controls Service Office.
2. Select SETUP
3. Select CONFIGURATION
4. Select OPERATIONS screen.
5. Press NUMBER of STARTS or OPERATING HOURS key as appropriate.
6. Using numeric keypad keys, enter desired number.
7. Press ENTER (✓) key.

SERVICE PHONE NUMBERS

(Applies to Flash Memory Card version C.MLM.01.05.xxx and later)

Two service phone numbers (Regional and Local), with labels, can be displayed on the OPERATIONS Screen. The Default value for the Regional number is the “Johnson Controls North American Parts Center Toll Free Number 1-800-861-1001”. However, the label and number can be changed to any desired value. The Default value for the Local label and number is blank. The Service Technician enters the Local phone number and label.

The entry format consists of 4 fields (rows), vertically from the top. Up to 40 characters/numbers can be entered for each field.

Field 1 – Regional phone number label. Default value is “Johnson Controls North American Parts Center Toll Free Number”

Field 2 – Regional phone number. Default value is 1-800-861-1001.

Field 3 – Local service phone number label. Default value is blank.

Field 4 – Local service phone number. Default value is blank.

Use the following procedure to change any of the fields:

1. At the Keypad, login at SERVICE access level using access code 1 3 8 0.
2. Select OPERATIONS Screen.
3. Press EDIT PHONE NUMBERS Key.
4. Use ▲ and ▼ keys to move green selection box to the desired field to be changed.
5. Press the ENTER (✓) key.
6. In the Dialog box that appears, a red box appears over the first changeable value. Use the ◀ and ▶ keys to position the red box over the number character to be changed or entered. Use the ▲ and ▼ keys to scroll sequentially through numbers, alphabet characters and punctuation marks to select the desired value. When the desired value displayed, use the ◀ and ▶ keys to move the red box to the next value to be changed. The numeric keypad keys can also be used to enter numbers.

Continue this process until all desired values have been entered.

7. After all desired values have been entered in previous step, press ENTER (✓) key.

SURGE PROTECTION

There are four editable values

HIGH HEAD MINIMUM VANE

LOW HEAD MINIMUM VANE

MAXIMUM PRESSURE DELTA

MINIMUM PRESSURE DELTA

The four above value are established by the factory engineering department based on chiller design and should not be changed arbitrarily. Contact factory engineering before making any changes.

There are two display values

PRESSURE DELTA

MINIMUM POSITON

HIGH HEAD MINIMUM VANE - Minimum vane position in percent for stable operation at high head condition

LOW HEAD MINIMUM VANE - Minimum vane position in percent for stable operation at low head condition

MAXIMUM PRESSURE DELTA – Maximum compressor differential pressure in PSID for stable operation

MINIMUM PRESSURE DELTA – Minimum compressor differential pressure in PSID for stable operation

PRESSURE DELTA – Condenser pressure minus Evaporator pressure

MINIMUM POSITION – Minimum vane position for stable operation

SALES ORDER DATA

All of the Sales Order Data, except the CHILLER COMMISSIONING DATE is entered at the YORK Factory at the time of chiller manufacture. The Service Technician must enter the Chiller Commissioning Date and modify the Job Name or Job Location if necessary at the completion of commissioning. Normally, the remainder of the Sales Order Data should never be modified.

However, if there is a change to the chiller design, in the field, this data can be modified. If the BRAM battery-backed memory device fails and requires field replacement, all of the data will be lost and will have to be manually programmed.

When replacing a microboard, it might be desirable to transfer the BRAM from the defective board to the replacement board to save stored Sales Order data. Since not all BRAM devices are compatible with all microboards, first determine if the BRAM can be transferred before making the transfer. Refer to the Microboard Service Replacement section of SECTION 4 of this manual.

There are three different Passwords used, depending on the circumstances, to change the Sales Order Data as follows:

- **Chiller Commissioning** - Service Technician must use password **1 3 8 0** to enter the Commissioning Date and modify Job Name and Job Location if necessary.
- **Modifying Sales Order Data** - Service Technician must use the ADMIN password. This password changes daily. Contact your local Johnson Controls Service Office.
- **BRAM Replacement** - If the BRAM is field replaced, the Service Technician must use password **0 2 2 8** to enter all Sales Order Data into a new blank BRAM. When logged in at this level, the ACCESS LEVEL shown will be TEST OP. This password only works with a blank.



*When using this password to enter data into a new blank BRAM, the **FINISH PANEL SETUP** procedure (listed at the end of the entry procedure below) must be performed after all data has been entered. Failure to perform this procedure will result in unreliable OptiView Control Center operation! If this procedure is performed prior to entering all data, the ability to enter more data will be terminated.*

Use the following procedure to enter data:

1. At the keypad, log in at the appropriate Access Level to change the desired values.
2. From the SETPOINTS Screen, select SETUP SCREEN. From the SETUP Screen, select SALES ORDER Screen.

3. If logged in at SERVICE Access level, press SET ORDER INFO key to enter Commissioning date, Job Name or Location and proceed to step 4. If logged in at ADMIN or TEST OP level, Press SELECT key to select the data category (ORDER, DESIGN, NAMEPLATE, SYSTEM) to be entered.
4. Press CHANGE key. The first changeable area in the selected category will be outlined in a green selection box. The procedure can be terminated anytime after this by pressing the CANCEL (X) key.
5. Use the ▲ and ▼ keys to move the green selection box to the desired value to be changed, within the category selected.
6. Press ENTER (✓) key.
7. Enter the appropriate data. Use the numeric keypad keys to enter numbers. Use the • key to enter a decimal point. Use the ▲ and ▼ keys to scroll sequentially up and down through the alphabet to enter letters or a comma (,), slash (/) or minus sign (-). Each time the ▲ key is pressed, the next higher sequential alphabet letter is displayed. Each time the ▼ key is pressed, the next lower alphabet letter is displayed. The comma, slash and minus sign can be selected after scrolling through the entire alphabet. During the entry process, the ◀ key can be used to backspace and the ▶ key can be used to forward space.
8. Press ENTER (✓) key.
9. Use ▲ and ▼ keys to select another value to be changed within the same category or press CANCEL (X) key to exit and allow selection of another category.
10. **Extremely Important!** If the procedure above was performed using password 0 2 2 8 to enter data into a new blank BRAM, the following procedure must be performed after all the desired data is entered. If the following procedure is performed prior to entering all of the data, the ability to enter more data will be terminated. Failure to perform this procedure after all data has been entered will result in unreliable OptiView Control Center Operation!
 - A. On SALES ORDER screen, press FINISH PANEL SETUP key.
 - B. Use ◀ and ▶ key to select YES.
 - C. Press ENTER (✓) key.

CUSTOM USER ID AND PASSWORDS

When logging in, the user is requested to enter a User ID, followed by a Password. The universal and Default User ID is zero (0). The universal Password to log in at OPERATOR access level is 9 6 7 5. The universal Password to log in at SERVICE access level is 1 3 8 0. No log in is required for VIEW access level. However, if desired, the service technician can establish up to four custom User ID's and Passwords that can be used by Operations personnel to log in at VIEW, OPERATOR, or SERVICE level.

Up to four Custom Users can be established with User ID's from 1 to 9999. Each user can be assigned a Password of 0 to 9999 and an access level of VIEW, OPERATOR or SERVICE.

Use the following procedure to establish Custom Users: At the HOME screen, log in at the SERVICE access level using 1380.

1. Start at the Home Screen
2. Setup
3. Configuration
4. User
5. Change Attributes
6. ▲ and ▼, ◀ and ▶ keys till Green Box is at the desired location
7. Press ENTER
8. Enter the number desired number or numbers
9. Press ENTER
10. ▼ key till Green Box is at INTERSTAGE VALVES
11. Press ENTER
12. Enter the number of interstage valves 1 or 2

FLOW SWITCHES

OM chillers require Paddle type flow sensors for the condenser and evaporator liquid flow.

TB4 Local Digital I/O Terminals 1 and 12 for the Evaporator

TB4 Local Digital I/O Terminals 1 and 11 for the Condenser

THIS PAGE INTENTIONALLY LEFT BLANK.

SECTION 19 - DIAGNOSTICS AND TROUBLESHOOTING

The problems that could be encountered in the OptiView Control Center are in the following categories:

- Keypad
- Display
- Serial Input/Output (I/O)
- Digital Input/Output (I/O)
- Analog Inputs

There is a Diagnostic and associated Troubleshooting procedure for each category. They are described on the following pages. Each Diagnostic is accessed from the Diagnostics Main Screen, which is entered using the procedure below. If there is an OptiView Control Center problem, determine the category of the problem. Then perform the applicable Diagnostic. If the Diagnostic reveals a malfunction, perform the Troubleshooting procedure to locate the defective component.

There are several documents that must be referred to while performing the Diagnostics and Troubleshooting procedures. Each procedure references the Section and figures of this manual that describe the operation of the component being tested. Also, the applicable OptiView Control Center wiring diagram must be used.

There are two versions of the Diagnostics screens available as follows:

1. Shown in *FIGURE 45* and *46*. These screens are used during the Diagnostics and Troubleshooting process. They allow output states to be changed. Access the Diagnostics Main Screen as follows:

- A. The chiller must be stopped.
 - B. Place Compressor Start/Stop switch in the Stop-Reset position (O).
 - C. Ensure the Compressor motor current is 0% FLA.
 - D. Log in at **SERVICE** access level using access code **1 3 8 0**.
 - E. Move Microboard Program Switch SW1-4 (microboard 031-01730-000); SW1-2 (microboard 031-02430-000 or 031-02430-001) to the ON position. A Watchdog reset will occur and the Boot-up process will commence. At the completion of the Boot-up process, the Diagnostics Main Screen will appear. (Note: if the Program Switch is moved to the ON position before step 4 above is performed, the **LOG IN** key will be displayed and Logging in at **SERVICE** access level must be performed before the Main Screen is displayed.
2. Not shown. Available when logged in at **SERVICE** access level, whether the chiller is running or not. Accessed from the **SETUP** screen via the **SETPOINTS** screen. There are two screens available that allow the Analog Inputs voltage levels and Digital I/O states to be monitored. These screens are preceded by a general screen that provides the installed software versions.

DIAGNOSTICS SCREEN



LD14327a

FIGURE 45 - DIAGNOSTICS SCREEN

This screen shows all of the software that is loaded onto the microboard and the motor starter connected to the microboard via serial communications.

Controls – Software that controls the chiller. On 031-01730-000 microboards, the program resides in the Flash Memory Card (U46). On 031-02430-000/001 microboards, the program resides in the non-removable flash memory chip (U35).

BIOS – BIOS eeprom on microboard

Kernel – software that is part of flash memory

GUI – Software that is part of the flash memory

SIO – software that is part of flash memory

GPIC – eeprom in the E-Link gateway

Ext I/O – Software in I/O Board 031-02895-000 (only displayed with Microboard software version C.OPT.01.21.307 and later).

MAIN DIAGNOSTICS SCREEN



LD14328a

FIGURE 46 - MAIN DIAGNOSTICS SCREEN

Each of the Diagnostics is accessed from this screen. Press the appropriate key to select the desired diagnostic. After each diagnostic is performed, return to this **MAIN** Screen, from which the next diagnostic can be selected.

Some of the diagnostics have sub-screens that are accessed from the selected diagnostic screen. The sub-screens are shown indented below:

Main screen

- Monitor Monitoring Board (software version C.OPT.01.22.307 and later)
- I/O Board (software version C.OPT.01.21.307 and later)
- Keypad test
- Display test
 - Bit patterns test
 - All red
 - All green
 - All blue
 - All white
 - All black
- Serial I/O test
- Digital I/O test
- Analog Inputs

The **ADVANCED SECURITY** key is used during the manufacturing process and has no field service use.

KEYPAD TEST

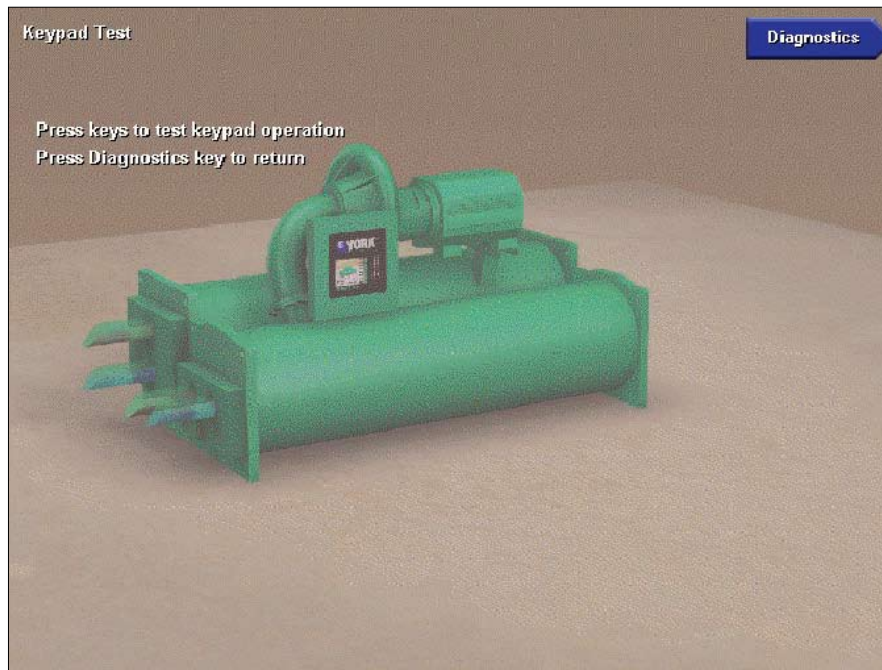

00336VIP

FIGURE 47 - KEYPAD TEST SCREEN

This diagnostic is used to verify Keypad operation and the Microboard's ability to respond to a pressed key.

PROCEDURE

1. Press each keypad key. As the key is pressed, an illuminated LED is displayed corresponding to the key location on the keypad.
2. Press the **DIAGNOSTICS** key to return to the **MAIN DIAGNOSTICS** Screen.

TROUBLESHOOTING

If an LED is not displayed when a key is pressed, the Keypad, Keypad Ribbon Cable or Microboard could be defective. Use the following procedure to locate the defective component.

1. Keypad

- A. Disconnect the Ribbon Cable from the Keypad.
- B. Identify row/column coordinate of the key to be tested. Refer to *FIGURE 37*.
- C. In the Keypad connector, locate the pins of the row/column coordinate of the key of the key to be tested.

- D. Insert the leads of an Ohmmeter into the pins identified in step "C".
- E. Press the key to be tested. If the contact resistance is greater than 100 Ohms, the Keypad is defective.
- F. Release the key. If the contact resistance is greater than 1 Meg Ohm, the Keypad is defective.

2. Ribbon Cable

Using an Ohmmeter, perform a continuity test on all conductors in the ribbon cable. An open circuit would indicate the Ribbon Cable is defective.

3. Microboard

There are no checks or measurements to be made on the Microboard. If the Keypad and Ribbon Cable check OK per the above procedures, the Microboard is most likely the cause of the problem.

DISPLAY TEST MAIN SCREEN

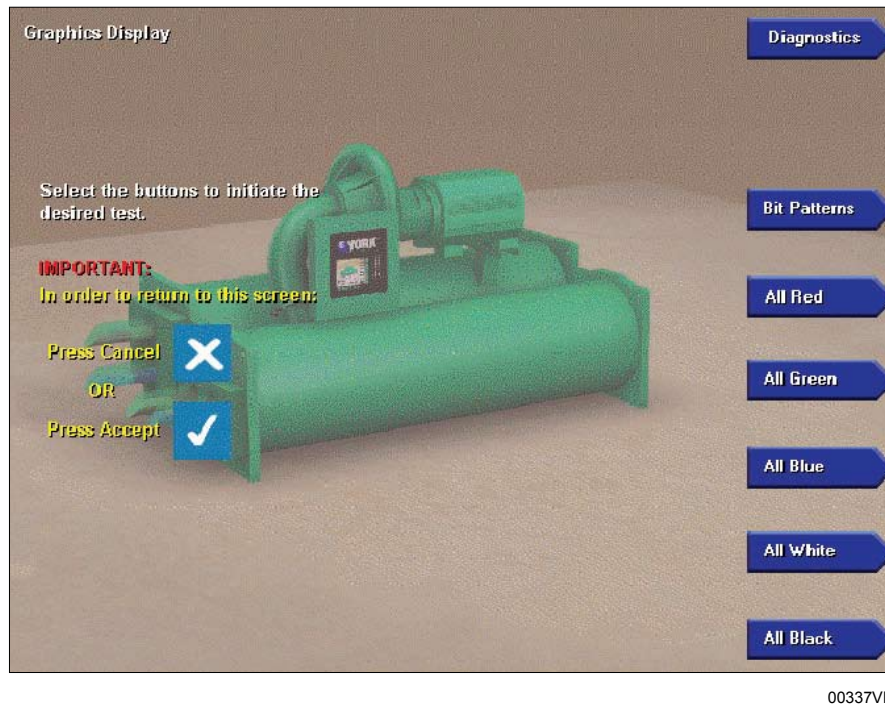

FIGURE 48 - DISPLAY TEST MAIN SCREEN

Each of the Display Diagnostics is accessed from this screen. After each diagnostic is performed, return to this screen, from which the next diagnostic can be selected. Refer to description of Display operation in *SECTIONS 5 through 7* of this manual.

PROCEDURE

1. Press the appropriate keypad key to perform the desired test from the list below.
2. Press the **CANCEL** (X) or **ENTER** (✓) key to terminate test and return to **DISPLAY TEST MAIN** screen, from which another test can be selected.
3. When all the desired tests have been performed, press the **DIAGNOSTICS** key to return to the **MAIN DIAGNOSTICS** screen.
 - **Bit Patterns** - This test is used to detect jitter and alignment defects. It verifies proper operation and compatibility of the Microboard Display Controller with the display. Four vertical bars of green, dark blue, light blue and yellow, outlined by a red border are displayed. If the vertical bars are not stable or straight, or the red border is not completely visible, then either the Microboard Program

Jumpers are not configured correctly for the installed display or the Microboard Display controller is defective.

- **All Red** - This test verifies the operation of all of the red pixels. All of the red pixels are turned on to create a completely red screen. Any red pixels that do not turn on will appear as black dots on the display. If any black dots appear, first ascertain it is not caused by dirt that is lodged between the display surface and the protective plastic cover. It is normal for a small number of randomly spaced pixels to not illuminate. It is not necessary to replace the display if a small number of black dots appear. They will not be visible on the normal screens displayed outside of this diagnostic mode. However, large black areas would be indicative of a defective display.
- **All Green** - This test verifies the operation of all of the green pixels. All of the green pixels are turned on to create a completely green screen. Refer to description of ALL RED test above.
- **All Blue** - This test verifies the operation of all of the blue pixels. All of the blue pixels are

turned on to create a completely blue screen.
Refer to description of ALL RED test above.

- **All White** - This test verifies the display's ability to turn on all pixels to display a completely white screen. Any pixel that does not turn on will appear as a black dot. Refer to description of ALL RED test above.
- **All Black** - This test verifies the display's ability to turn off all pixels to display a completely black screen. Any pixel that does not turn off will appear as a red, green, blue or white dot. Refer to description ALL RED test above.

BIT PATTERNS TEST SCREEN

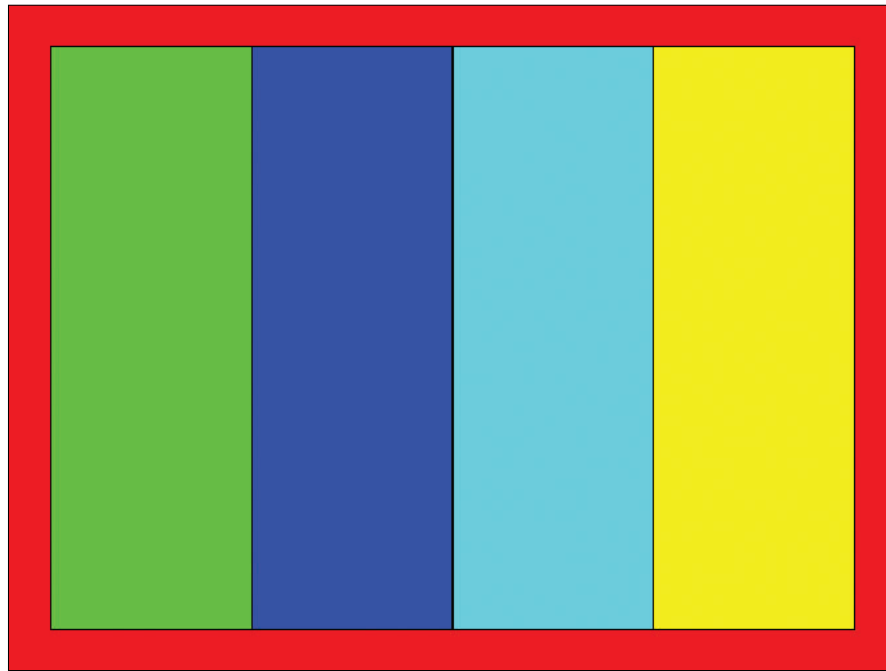

00338VIP

FIGURE 49 - BIT PATTERNS TEST SCREEN

TROUBLESHOOTING

If any of the above tests do not perform correctly as described above, perform the applicable procedure below:

Test Failed

Bit Patterns - If the vertical bars are not straight or if the red border is not completely visible, either the Microboard Program Jumpers are not configured correctly or for the installed Display or the Microboard is defective.

All Red, All Green, All Blue, All White or All Black

If these tests do not produce appropriate solid color screens, the Display Ribbon Cable, Display Interface Board, Microboard or Display could be defective. To locate the defective component perform tests in the following order:

1. Display Ribbon Cable

Using an Ohmmeter, perform a continuity test on all conductors in the ribbon cable. An open circuit would indicate the ribbon cable is defective.

2. Display Interface Board

Using an Ohmmeter, perform a continuity test on all conductors of the Interface Board. An open circuit would indicate the Interface Board is defective.

3. Microboard

- A. With the ALL RED test selected, the voltage at Microboard J5-6 through J5-11 (Red drivers bits 0-5), as measured to Gnd, should be greater than 3.0VDC. If not, the Microboard is defective.
- B. With the ALL GREEN test selected, the voltage at Microboard J5-13 through J5-18 (Green drivers bits 0-5), as measured to Gnd, should be greater than 3.0VDC. If not, the Microboard is defective.
- C. With the ALL BLUE test selected, the voltage at Microboard J5-20 through J5-25 (Blue drivers bits 0-5), as measured to Grid, should be greater than 3.0VDC. If not, the Microboard is defective.

- D. With the ALL WHITE test selected, the voltage at Microboard J5-6 through J5-11, J5-13 through J5-18 and J5-20 through J5-25 should be greater than 3.0VDC. If not, the Microboard is defective.
- E. With the ALL BLACK test selected, the voltage at Microboard J5-6 through J5-11, J5-13 through J5-18 and J5-20 through J5-25 should be greater than 1.0VDC. If not, the Microboard is defective.

4. Display

If the Display Ribbon Cable, Display Interface Board and Microboard check OK per the above procedures, the Display is most likely the cause of the problem.

SERIAL INPUTS / OUTPUTS TEST SCREEN

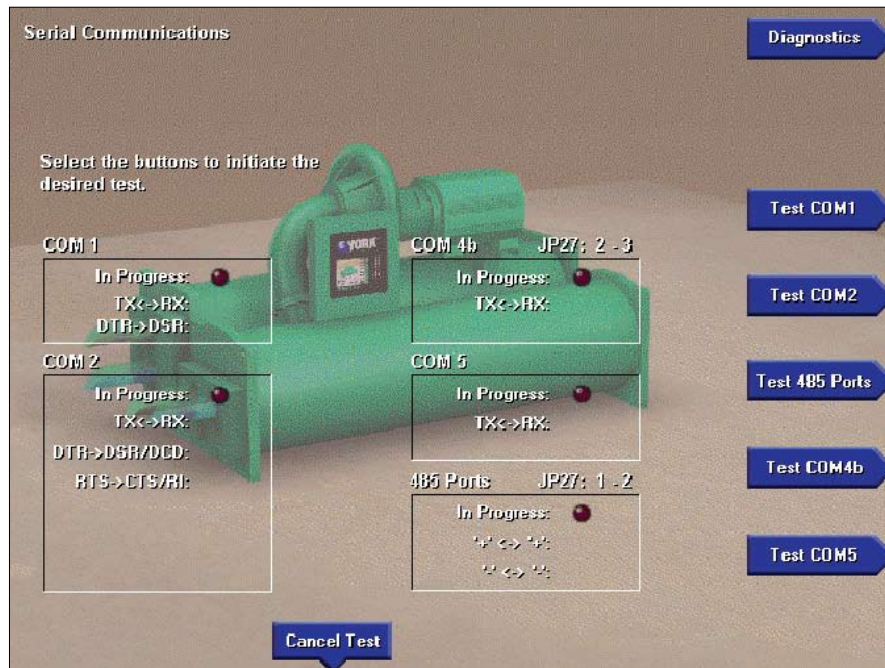

00339VIP

FIGURE 51 - SERIAL INPUTS / OUTPUTS TEST SCREEN

This diagnostic is used to verify correct operation of the Serial Data Ports. There is a test for each of the five Serial Data Ports. Each RS-232 port (COM 1, 2 and 4b) is tested by transmitting serial test data from outputs to inputs of each port. Both the transmit and receive functions as well as the control lines are tested. The RS-485 ports (COM 3 and 4a) are tested by transmitting serial test data from one RS-485 port to another. The TX/RX opto-coupled port (COM 5) is tested by transmitting serial test data from the TX output to the RX input. If the received data matches the transmitted data, PASS is displayed, indicating the serial port is OK. Otherwise, FAIL is displayed, indicating the serial port is defective. Prior to performing each test, the Service Technician must install a wire loop-back connection as described below. Refer to *SECTION 3 - MICROBOARD 031-01730-000* and *FIGURE 9* of this manual for description of the Serial data Ports.

PROCEDURE

- Using small gauge wire, fabricate loop-back connections and install as follows for each port to be tested. Failure to install the loop-back connection or configure the Microboard Program jumper as noted will result in a FAIL outcome for the test.

	From	To
COM 1	J2-4 (TX)	J2-3 (RX)
	J2-5 (DTR)	J2-2 (DSR)

	From	To
COM 2	J13-5 (TX)	J13-3 (RX)
	J13-7 (DTR)	J13-1(DCD) and J13-2(DSR)
	J13-4 (RTS)	J13-6 (CTS) and J13-8 (RI)

	From	To
RS-485 (COM 3 and 4a)	J12-3 (+)	J11-3 (+)
	J12-2 (-)	J11-2 (-)

Microboard Program Jumper JP27 must be installed in position 1 and 2.

	From	To
COM 4b	J2-7 (GTX)	J2-6 (GRX)

Microboard Program Jumper JP27 must be installed in position 2 and 3.

	From	To
COM 5	J15-1 (TX)	J15-4
	J15-2 (RX)	J15-5
	J15-3 (Common)	J15-6

Make individual wire connections or use YORK loop-around diagnostic connector 025-33778-000. This connector is available from the Baltimore Parts Center.

- After connecting appropriate loop-back connections above, press the appropriate key to initiate the desired test. An LED will illuminate indicating the test is in progress. If it is desired to terminate the test, press the CANCEL TEST key. Test data is sent from an output to an input as described below. At the completion of each test, if the data received matches the data sent, the Serial Port operates properly and PASS is displayed. Otherwise, FAIL is displayed, indicating the Serial Port is defective. A FAIL result would be indicative of a defective Microboard. The following is a description of each test.

COM 1 – Two tests are performed. Test data is sent from TX (J2-4) to RX (J2-3) at 9600 Baud and DTR (J2-5) is set to a Logic High level and read at DSR (J2-2). If any test fails, COM 1 tests are terminated.

COM 2 – Three tests are performed. Test data is sent from TX (J13-5) to RX (J13-3) at 19200 Baud. DTR (J13-7) is set to a Logic High and read at DSR (J13-2) and DCD (J13-1). RTS (J13-4) is set to a Logic High and read at CTS (J13-6) and R1 (J13-8). If any test fails, COM 2 tests are terminated.

RS-485 (COM 3 and 4a) – Test data is sent from COM 3 RS-485 port to COM 4a RS-485 Port at 19200 Baud. Test data is then sent from COM 4a to COM 3 at the same rate. If either test fails, RS-485 tests are terminated.

COM 4b – Test data is sent from GTX (J2-7) to GRX (J2-6) at 19200 Baud.

COM 5 – Test data is sent from TX (J15-1) to J15-4 at 1200 Baud. This output turns the Microboard's loop-around test Transistor on and off, applying 0/+5VDC pulses from J15-5 to RX (J15-2) input.

- After all desired tests have been performed, press the **DIAGNOSTICS** key to return to the **MAIN DIAGNOSTICS** Screen.

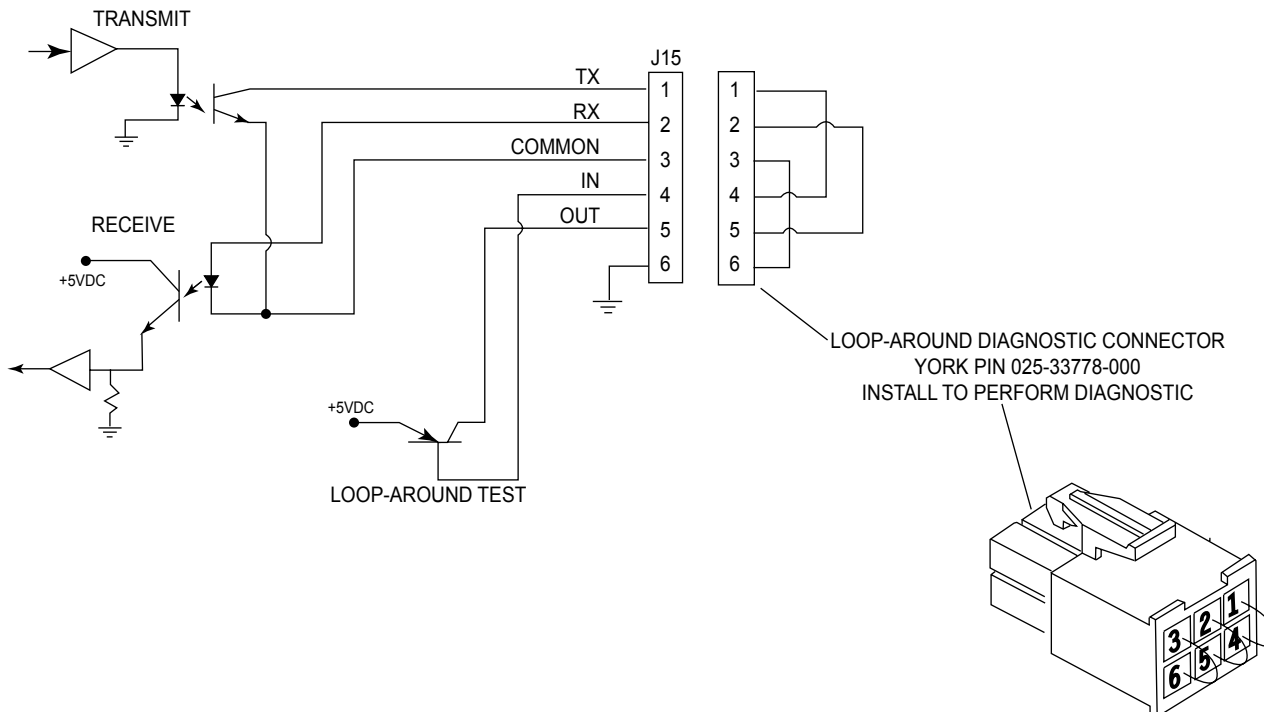

LD04250

FIGURE 50 - MICROBOARD -COM 5 SERIAL DATA PORT

DIGITAL INPUTS / OUTPUTS TEST SCREEN

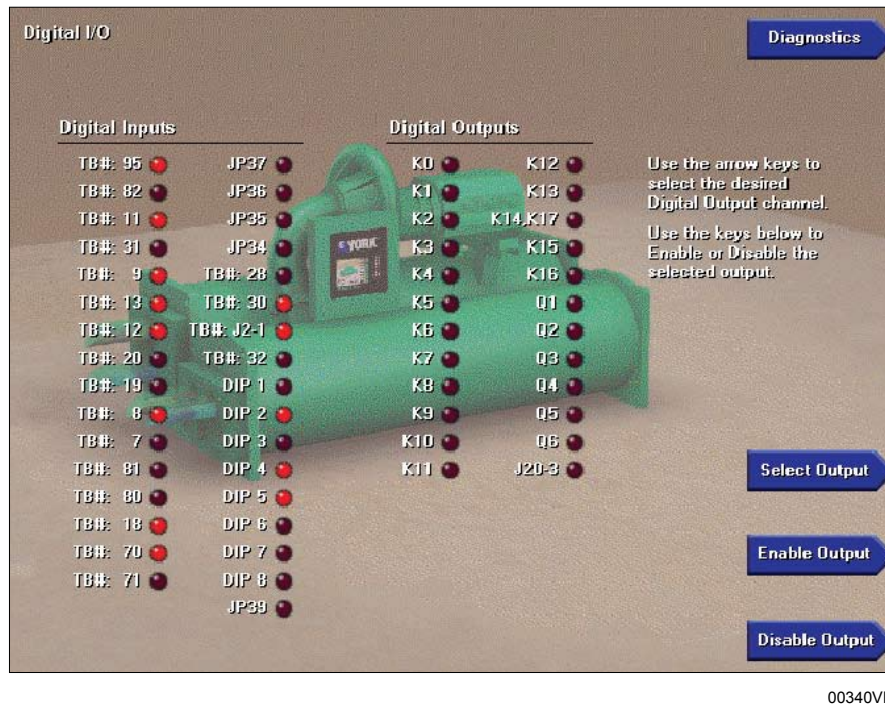

00340VIP

FIGURE 52 - DIGITAL INPUTS / OUTPUTS TEST SCREEN

This diagnostic is used to analyze the digital inputs and outputs of the Microboard. Refer to *SECTION 5 - I/O BOARD* for description of I/O Board.

The state of each Microboard Digital Input, Program Jumper and Program DIP Switch, as interpreted by the Microboard, is depicted by an LED. If the Microboard interprets its input as being at a Logic Low (less than 1.0VDC) level, the LED is illuminated. If interpreted as being at a Logic High (greater than 4.0VDC) level, the LED is extinguished.

The state of the Microboard's intended drive signals to each of the Relays on the I/O Board is depicted by an LED. If the intended output is a Logic Low level (less than 1.0VDC), the LED is illuminated. If the intended output is a Logic High level (greater than 10.0VDC), the LED is extinguished. Logic Low outputs energize the Relays. Logic High outputs de-energize the Relays. The state of any output can be manually set to either the ENABLED (Logic Low) or DISABLED (Logic High) state.

PROCEDURE

Digital Inputs

1. The Digital Inputs are listed on this screen according to a.) Terminal number on the I/O Board and b.) Microboard Program Jumpers and Program DIP Switches. *FIGURE 20* shows the devices connected to these terminals. *SECTION 3* and *4* list the functions of the Program Jumpers and Switches.
2. With 115VAC applied to a particular I/O Board Digital Input, the applicable LED should be illuminated. If the LED is not illuminated, perform appropriate Troubleshooting procedure below.
3. With 0VAC applied to a particular I/O Board Digital Input, the applicable LED should be extinguished. If the LED is not extinguished, perform appropriate Troubleshooting procedure below.
4. If a Program Jumper is present, the applicable LED should be extinguished. If the LED is not extinguished, the Microboard is defective.
5. If a Program Jumper is not present, the applicable LED should be illuminated. If the LED is not illuminated, the Microboard is defective.

6. If a Program Switch (DIP) is in the ON position, the applicable LED should be illuminated. If the LED is not illuminated, the Microboard is defective.
7. If the Program Switch (DIP) is in the OFF position, the applicable LED should be extinguished. If the LED is not extinguished, the Microboard is defective.
8. When all desired tests have been performed, press **DIAGNOSTICS** key to return to **MAIN DIAGNOSTICS** Screen.

Digital Outputs

1. **IMPORTANT!** - The following steps cannot be performed until the Motor Controller connection between TB6-1 and TB6-53 has been removed. This connection could be a jumper or it could be a connection from external devices in the starter. The Program will prevent manual control of Digital Output devices until this connection is removed.
2. The Digital Outputs are listed on this Screen according to Relay and Triac number (KI, Q3, etc). *FIGURE 23* shows the external devices that are connected to these Relays and Triacs and the functions of each one.
3. Press **SELECT** key. An arrow will appear adjacent to Relay KO.
4. Select a relay or triac for manual control by using the ◀ and ▶ keys to place the arrow adjacent to the desired device.
5. Press the **ENABLE OUTPUT** key to enable the selected output. The LED adjacent to the selected output should illuminate. If it does not, perform **KEYPAD** Diagnostics test. If a relay is selected, it should energize, closing its contacts. If a triac is selected, it will turn on, energizing the device it is connected to. If the relay does not energize or triac does not turn on, perform appropriate troubleshooting procedure below.
6. Press the **DISABLE OUTPUT** key to disable the selected output. The LED adjacent to the selected output should extinguish. If it does not, perform **KEYPAD** diagnostic test. If a relay is selected, it should de-energize, opening its contacts. If a triac is selected, it will turn off, de-energizing the device it is connected to. If relay does not de-ener-

gize or triac does not turn off, perform appropriate troubleshooting procedure below.

7. When all desired tests have been performed, press **DIAGNOSTICS** key to return to the **MAIN DIAGNOSTICS** Screen.
8. Install Motor Controller connection from TB6-1 to TB6-53 removed in step 1.

Digital Inputs Troubleshooting

If any of the Digital Inputs tests fail to perform as described above, perform the following steps in sequence. Refer to *FIGURE 20* and applicable wiring diagram. If a defective component is found during any of the following steps, replace the component as instructed and repeat the digital Inputs Procedure above to determine if the problem has been resolved.

1. Remove I/O Board ribbon cable. Using an Ohmmeter, perform a continuity check on I/O Board ribbon cable J1-21 to J19-21, J1-22 to J19-22 and applicable output pin of function that failed in Procedure above. If an open circuit is detected, replace ribbon cable. Otherwise, install ribbon cable and proceed to next step.
2. Measure the +5VDC supply voltage to the I/O Board on I/O Board between J1-21 and J1-22. If greater than 4.5VDC, proceed to next step. If less than 4.5VDC, disconnect ribbon cable at I/O Board J1 and repeat the measurement at J1. If less than 4.5VDC, replace the Microboard. Re-install the ribbon cable.
3. With 115VAC ($\pm 10\%$) applied to the I/O Board digital input that failed in Procedure above, the applicable I/O Board output at J1 should be at a Logic low level (less than 1.0VDC). If it is greater than 1.0VDC, replace the I/O Board. If the output is at a Logic Low level, the applicable LED should be illuminated. If the LED is not illuminated, replace the Microboard.
4. With 0VAC applied to the I/O Board digital input that failed in Procedure above, the applicable I/O Board output at J1 should be at a Logic High level (greater than 4.0VDC). If it is less than 4.0VDC, replace the I/O Board. If the output is at a Logic High level, the applicable LED should be extinguished. If it is not extinguished, replace the Microboard.

Digital Outputs Troubleshooting

If any of the Digital outputs tests fail to perform as described above, perform the following steps in sequence. Refer to *FIGURE 23* and applicable wiring diagram. If a defective component is found during any of the steps, replace the component as instructed and repeat the Procedure above to determine if the problem has been resolved.

1. Remove I/O Board ribbon cable. Using an Ohmmeter, perform a continuity test on the cable J1-25 to J19-25, J1-26 to J19-26 and applicable output pin of function that failed in Procedure above. If an open circuit is detected, replace ribbon cable. Otherwise, install ribbon cable and proceed to next step.
2. Measure the +12VDC supply voltage to the I/O Board on I/O Board between J1-26 (+12VDC) and J1-25 (Gnd). If greater than 11.0VDC, proceed to next step. If less than 11.0VDC, disconnect ribbon cable at I/O Board J1 and repeat measurement at J1. If less than 11.0VDC, replace the Microboard. Re-install the ribbon cable.
3. Using the Digital Outputs Procedure above, select the output that failed the digital Output test above.
4. Press **ENABLE OUTPUT** key. The LED adjacent to the selected output will illuminate. The appropriate Microboard output pin at J19 for the selected output should be at a Logic Low level (less than 1.0VDC). If it is greater than 1.0VDC, replace the Microboard. With the output at a Logic Low, the following should occur:
 - A. If a Relay is selected as the output, the contacts of the relay should be closed. If they are not closed, replace the I/O Board.
 - B. If a Triac is selected as the output, the Triac should be turned on. If the Triac has not turned on, replace the I/O Board. See note 1 below for Triac testing.
5. Press **DISABLE OUTPUT** key. The LED adjacent to the selected output will extinguish.
 - A. If a Relay is selected as the output, the appropriate Microboard output pin at J19 for the selected output should be at a Logic High (greater than 10.0VDC) level. With the out-

put at a Logic High level, the relay contacts should be open. If they are not open, replace the I/O Board. If it is less than 10.0VDC, remove the ribbon cable from J1 of the I/O Board. On the I/O Board, measure the resistance from J1-26 to the appropriate pin of J1 on the I/O Board for the selected relay. If the resistance is greater than 100 Ohms, replace the I/O Board. If the resistance is less than 100 Ohms, replace the Microboard.

- B. If a Triac is selected as the output, the appropriate Microboard output pin at J19 for the selected output should be at a Logic High (greater than 10.0VDC) level. If it is less than 10.0VDC, replace the Microboard. With the output at a Logic High level, the Triac should be turned off. If the Triac has not turned off, replace the I/O Board. See note 1 below for Triac testing.

Notes

The load (actuator) must be connected across the Triac to determine the on/off state of the Triac. The on/off state of the Triac can be determined by measuring across the device (for example, TB1-3 to TB1-59 or TB1-58 to TB1-59) with an AC Voltmeter. If the Triac is turned on, the voltage will be less than 10VAC. If the Triac is turned off, the voltage will be greater than 100VAC (Slide Valve Actuator) or greater than 20VAC (PRV, Hot Gas or Refrigerant Level Control Actuator).

ANALOG INPUTS TEST SCREEN

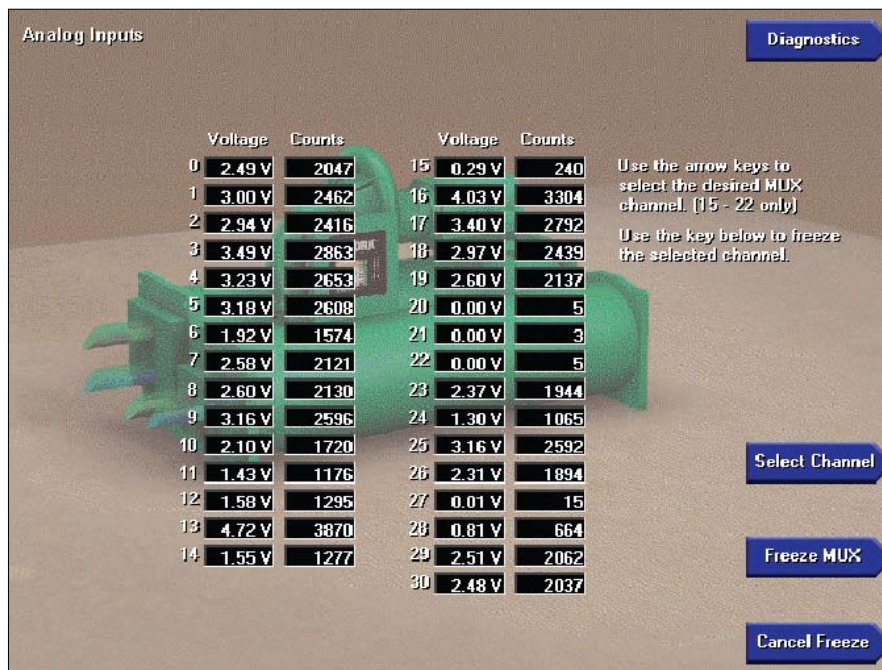

00341VIP

FIGURE 53 - ANALOG INPUTS TEST SCREEN

This diagnostic is used to analyze the Analog Inputs to the Microboard. The voltage level of each Analog input, as interpreted by the Microboard, is displayed. The COUNTS listed for each parameter is the Analog-to-Digital (A/D) converter value and is for manufacturing and engineering use only.

If the chiller is shutting down on an Analog Safety or is prevented from starting because of an Analog input, there is probably an Analog Input problem. This Screen can be used in the investigation of this problem.

Important! This test does not apply to the Leaving Chilled Liquid Temperature analog input, Proximity Probe DC Voltage reference or a 0-10VDC Remote Setpoint input at channels 27 and 28.

The following is a list of the Analog inputs displayed. Refer to the appropriate Section of this manual for an explanation of each: *SECTION 14-PRESSURE TRANSDUCERS*, *SECTION 15-TEMPERATURE TRANSMITTERS*, *SECTION 12-SOLID STATE STARTER AND SECTION 11-CURRENT MODULE (CM-2)*.

Channel

- 0 - +2.5VDC Analog supply voltage reference. Microboard TP6.
- 1 - Not Used
- 2 - Return Chilled Liquid Temperature
- 3 - Leaving Condenser Liquid Temperature
- 4 - Return Condenser Liquid Temperature
- 5 - Drop Leg Refrigerant Temperature
- 6 - Discharge Temperature
- 7 - Oil Temperature
- 8 - Evaporator Refrigerant Temperature
- 9 - Condenser Pressure
- 10 - Evaporator Pressure
- 11 - Sump Oil Pressure
- 12 - Pump Oil Pressure

- 13 - Proximity Probe DC Voltage Reference
(Not applicable to “P” compressors and style “F” and later chillers with “G, Q” and “H5-8” compressors)
- 14 - Proximity Probe Position (Not applicable to “P” compressors and style “F” and later chillers with “G, Q” and “H5-8” compressors)
- 15 - Solid State Starter/CM-2 MUX output Channel 0
- 16 - Solid State Starter/CM-2 MUX output Channel 1
- 17 - Solid State Starter/CM-2 MUX output Channel 2
- 18 - Solid State Starter/CM-2 MUX output Channel 3
- 19 - Solid State Starter/CM-2 MUX output Channel 4
- 20 - Solid State Starter/CM-2 MUX output Channel 5
- 21 - Solid State Starter/CM-2 MUX output Channel 6
- 22 - Solid State Starter/CM-2 MUX output Channel 7
- 23 - Refrigerant Level Position
- 24 - Stall Transducer Output (Chillers equipped w/ Variable Geometry Diffuser) (Software version C.MLM.01.14.xxx (and later) or C.OPT.01.14.306 (and later))
- 25 - Stall Detector Board output (chillers equipped with Variable Geometry Diffuser only) (Software version C.MLM.01.10.xxx (and later) or C.OPT.01.10.302 (and later))
- 26 - Pre-rotation Vanes Potentiometer output (chillers equipped with Variable Geometry Diffuser but not equipped with compressor motor Variable Speed Drive or Hot Gas Bypass) (Software version C.MLM.01.10.xxx (and later) or C.OPT.01.10.302 (and later))
- 27 - Remote Leaving Chilled Liquid Temperature Setpoint (0-20mA or 4-20mA)
- 28 - Remote Current Limit Setpoint (0-20mA or 4-20mA)
- 29 - Condenser Flow Sensor (style F and later chillers) (Flash Memory Card version C.MLM.01.07.xxx and later).
- 30 - Evaporator Flow Sensor (style F and later chillers) (Flash Memory Card version C.MLM.01.07.xxx and later)

Procedure

1. From the chart above, select the analog input that is malfunctioning. All inputs except channel 0, 15 through 22, 27 and 28 are sensors that connect directly to the Microboard via shielded cable. Channel 0 is a reference voltage for the Analog circuits on the Microboard. Channels 15 through 22 are multiplexed outputs from the Solid State Starter (Solid State Starter applications) or CM-2 Current Module (Electro-Mechanical Starter applications). Channels 27 and 28 are Remote Setpoint inputs used in Analog Remote mode.
2. Refer to Wiring Diagrams to identify the device that performs this function and the jack and pin connection to the Microboard.

3. Channel 0

Using a Voltmeter, measure the voltage between Microboard TP6 (+2.5VDC) and TP1 (Gnd).

Compare this measured value to the displayed value. If the value is not within $\pm 10\%$, replace the Microboard.

All channels except 0, 1, 15-22

Using a Voltmeter, measure the analog input to the Microboard. Make the measurement between the device output and Ground connection to the device. For example, measure the output of the Evaporator Transducer at Microboard J8-18 (signal) to J8-9 (Gnd).

Channels 15-22

Select the desired channel by pressing the **SELECT CHANNEL** key and using the \checkmark and \checkmark keys to place the arrow head next to the desired channel. Then, freeze the address of that channel to the Solid State Starter or CM-2 MUX. Then measure MUX output at Microboard J10-6 (signal) to J10-5 (Gnd). When completed, press **CANCEL FREEZE** key.

Channels 27, 28

IMPORTANT! This procedure only applies to 4-20mA inputs. It does not apply to 0-10VDC inputs. Using a Voltmeter, measure the Remote Current Limit setpoint input at J22-2 (signal) or Remote Leaving Chilled Liquid Temperature setpoint input at J22-4 (signal) to J22-5 (Gnd).

4. Compare the measured value in the previous step with the value displayed on the Analog Inputs Screen for that value.
 5. If the measured value is not within $\pm 15\%$ of the displayed value, replace the Microboard. Otherwise, proceed to the troubleshooting procedure below to find the cause of the problem.
 6. When all desired tests have been performed, press **DIAGNOSTICS** key to return the **MAIN DIAGNOSTICS** Screen.
3. Using a Voltmeter, measure the +5VDC supply voltage to the Solid State Starter Logic Board or CM-2 Board. Make measurement at Microboard J10-4(+5VDC) to J10-5 (Gnd). If voltage is less than 4.5VDC, replace the Microboard.
 4. Using a Voltmeter, verify the correct address is being sent from the Microboard to the Solid State Starter Logic Board or CM-2 Board. Freeze address as described above. If the address is correct, the Solid State Starter Logic Board or CM-2 Board or input devices to these boards is most likely the cause of the problem. If address is not correct, the Microboard is most likely the cause of the problem.
 5. Press **CANCEL FREEZE** key.

Troubleshooting

All Channels except 0, 1, 15-22, 27, 28

1. Disconnect both ends of the cable of the Analog input that is malfunctioning. Using an Ohmmeter, perform a continuity test on all conductors in the cable. An open circuit would indicate the cable is defective.
2. Using a Voltmeter, measure the +12VDC supply voltage input at the Microboard J1-3 (+12VDC) to J1-2 (Gnd). If voltage is less than 11.5VDC, check wiring to Power Supply. If wiring is OK, the Power supply is most likely defective.
3. Using a Voltmeter, measure the supply voltage (+5VDC, +1 2VDC or +24VDC) to the sensor. If voltage is not within +10% of specified voltage, disconnect J7, J8 and J9 from the Microboard. This disconnects all analog devices from the Microboard. If the voltage increases to the correct level, a Transmitter or Transducer is shorted. Locate the shorted device and replace. If, after disconnecting the connectors the supply voltage is still not within 10% of the specified value, the voltage supply source (Microboard or Power Supply) is most likely defective.
4. Verify sensor accuracy using appropriate test device. Replace sensor if necessary.

Channels 15 - 22

1. Disconnect both ends of ribbon cable connected to Microboard J10. Using an Ohmmeter, perform a continuity test on all conductors in the cable. An open circuit would indicate the cable is defective.
2. Using a Voltmeter, measure the +12VDC supply voltage input at the Microboard J1-3 (+12VDC) to J1-2 (Gnd). If voltage is less than 11.5VDC, check wiring to Power Supply. If wiring is OK, the Power Supply is most likely defective.

Channels 27, 28

1. Refer to Microboard Program Jumpers and verify Program Jumpers JP23 and JP24 are configured correctly for the type of input (0-10VDC or 4-20mA).
2. Disconnect both ends of the cable of the remote input that is malfunctioning. Using an Ohmmeter, perform a continuity check on all conductors in the cable. An open circuit would indicate the cable is defective.
3. If steps are OK, problem most likely is in the remote device that supplies the remote signal.

SECTION 20 - SYSTEM COMMISSIONING

FORM 160.72-CL1 (810)

 BY JOHNSON CONTROLS		MODEL – TITAN
--	--	---------------

YORK OM OPTIVIEW CONTROLS RETROFIT POINT-TO-POINT CHECKLIST

*TO: _____ JOB NAME: _____
 _____ LOCATION: _____
 _____ CUSTOMER ORDER NO. _____

YORK TEL. NO. _____ YORK ORDER NO. _____ YORK CONTRACT NO. _____
 CHILLER _____

MODEL NO. _____	SERIAL NO. _____
The work (as checked below) is in process and will be completed by _____ / _____ / _____ <div style="display: flex; justify-content: space-around; font-size: 0.8em;"> Month Day Year </div>	

GENERAL

- Field devices are installed and external control wiring to control panel completed in accordance with YORK wiring diagrams
- Control power supply available
- Pneumatic control piping completed and supply and control air pressure available

ANALOG INPUTS

DEVICE	DESCRIPTION	PASS
CT-1,2,3	Compressor Motor Current Transformers	<input type="checkbox"/>
LT-114	Subcooler Refrigerant Liquid Level	<input type="checkbox"/>
PT-111	Evaporator Refrigerant Pressure	<input type="checkbox"/>
PT-113	Compressor Discharge Pressure	<input type="checkbox"/>
PT-115	Intercooler Refrigerant Pressure	<input type="checkbox"/>
PT-140	Compressor Supply Oil Pressure	<input type="checkbox"/>
PT-143	Compressor Sump Oil Pressure	<input type="checkbox"/>
PT-144	Compressor Shaft Pump Oil Pressure	<input type="checkbox"/>
PT-146	Compressor Balance Piston Pressure	<input type="checkbox"/>
PT-147	Compressor Thrust Bearing Oil Pressure	<input type="checkbox"/>
PT-150	Gear Supply Oil Pressure	<input type="checkbox"/>
PT-156	Gear Shaft Pump Oil Pressure	<input type="checkbox"/>
PT-180	Supply Air Pressure	<input type="checkbox"/>
TT-100	Chilled Water Leaving Temperature	<input type="checkbox"/>
TT-101	Chilled Water Entering Temperature	<input type="checkbox"/>
TT-102	Condenser Water Entering Temperature	<input type="checkbox"/>
TT-103	Condenser Water Leaving Temperature	<input type="checkbox"/>
TT-106	Intercooler Refrigerant Liquid Temperature	<input type="checkbox"/>
TT-111	Evaporator Refrigerant Liquid Temperature	<input type="checkbox"/>
TT-112	Compressor Suction Temperature	<input type="checkbox"/>
TT-113	Compressor Discharge Temperature	<input type="checkbox"/>
TT-114	Subcooler Refrigerant Liquid Temperature	<input type="checkbox"/>
TT-115	Condenser Refrigerant Liquid Temperature	<input type="checkbox"/>
TT-140	Compressor Supply Oil Temperature	<input type="checkbox"/>
TT-142	Compressor Shaft End Bearing Oil Return Temperature	<input type="checkbox"/>

FORM 160.72-CL1 (810)

ANALOG INPUTS (CONT'D)

TT-143	Compressor Sump Oil Temperature	<input type="checkbox"/>
TT-147	Compressor Thrust Bearing Oil Return Temperature	<input type="checkbox"/>
TT-150	Gear Supply Oil Temperature	<input type="checkbox"/>
TT-151	Gear High Speed Shaft End Bearing Temperature	<input type="checkbox"/>
TT-152	Gear High Speed Blind End Bearing Temperature	<input type="checkbox"/>
TT-153	Gear Low Speed Blind End Bearing Temperature	<input type="checkbox"/>
TT-154	Gear Low Speed Shaft End Bearing Temperature	<input type="checkbox"/>
TT-161	Motor Shaft End Bearing Temperature	<input type="checkbox"/>
TT-162	Motor Blind End Bearing Temperature	<input type="checkbox"/>

BINARY INPUTS

DEVICE	DESCRIPTION	PASS
PDSLL-100	Chilled Water Low Differential Pressure	<input type="checkbox"/>
PDSLL-102	Condenser Water Low Differential Pressure	<input type="checkbox"/>
PDSLL-140A	Compressor Oil Low Differential Pressure	<input type="checkbox"/>
PSHH-113A	Compressor Discharge High Pressure	<input type="checkbox"/>
PSLL-111	Evaporator Low Pressure	<input type="checkbox"/>
PSLL-150	Gear Oil Low Pressure	<input type="checkbox"/>
TSHH-147	Compressor Thrust Bearing Oil High Temperature	<input type="checkbox"/>
TS-120	Oil Separator Temperature Switch	<input type="checkbox"/>
M2	Compressor Auxiliary Oil Pump Motor Starter Interlock	<input type="checkbox"/>
M3	Gear Auxiliary Oil Pump Motor Starter Interlock	<input type="checkbox"/>
MIR	Compressor Motor Full Voltage Run Contacts	<input type="checkbox"/>
MPD	Compressor Motor Protection Device Contacts	<input type="checkbox"/>
ZS-100A	Vane Motor Switch	<input type="checkbox"/>

ANALOG OUTPUTS

DEVICE	DESCRIPTION	PASS
LY-114	Subcooler Liquid Level Control Valve	<input type="checkbox"/>
PDY-115	Interstage Valve	<input type="checkbox"/>
TY-100A	Compressor Pre-Rotation Vanes	<input type="checkbox"/>
TY-100C	Hot Gas Bypass Valve	<input type="checkbox"/>

FORM 160.72-CL1 (810)

BINARY OUTPUTS

DEVICE	DESCRIPTION	PASS
FCV-104	Auxiliary Cooling Water Solenoid Valve	<input type="checkbox"/>
FCV-114	Interstage Liquid Injection Solenoid Valve	<input type="checkbox"/>
FCV-120	Oil Eductor Solenoid Valve	<input type="checkbox"/>
HTR-120A/B	Oil Separator Heaters	<input type="checkbox"/>
HTR-143A/B	Compressor Oil Sump Heaters	<input type="checkbox"/>
HTR-160A/B	Motor Space/Motor Exciter Heaters	<input type="checkbox"/>
M1	Compressor Motor Start/Stop	<input type="checkbox"/>
M2	Compressor Auxiliary Oil Pump Start/Stop	<input type="checkbox"/>
M3	Gear Auxiliary Oil Pump Start/Stop	<input type="checkbox"/>
PCV-100A	Compressor Pre-Rotation Vanes Air Dump Solenoid Valve	<input type="checkbox"/>
PCV-100C	Hot Gas Bypass Valve Air Dump Solenoid Valve	<input type="checkbox"/>
PCV-143	Compressor Sump Vent Solenoid Valve	<input type="checkbox"/>

20

With reference to the terms of the above contract, we are requesting the presence of your Authorized Representative at the job site on
 Month _____ / Day _____ / Year _____ to start the system and instruct operating personnel HAVE CONTACT _____
Names

We understand that the services of the YORK/Johnson Controls Authorized Representative will be furnished in accordance with the contract for a period of time of not more than _____ consecutive normal working hours, and we agree that a charge of _____ per diem plus travel expenses will be made to Johnson Controls if services are required for longer than _____ consecutive normal hours or if repeated calls are required, through no fault of YORK/Johnson Controls.

Signed: _____
Title: _____

 BY JOHNSON CONTROLS		MODEL – TITAN
--	--	---------------

YORK OM OPTIVIEW CONTROLS RETROFIT START-UP CHECKLIST

*TO: _____ JOB NAME: _____
 _____ LOCATION: _____
 _____ CUSTOMER ORDER NO. _____

YORK TEL. NO. _____ YORK ORDER NO. _____ YORK CONTRACT NO. _____
 CHILLER _____

MODEL NO. _____	SERIAL NO. _____
The work (as checked below) is in process and will be completed by _____ / _____ / _____ <div style="display: flex; justify-content: space-around; font-size: 8pt;"> Month Day Year </div>	

A. GENERAL

- Review the Pre-functional Checklist verifying work required has been completed.
- Chiller is charged with refrigerant.
- Chiller is charged with oil.
- Oil sump heaters have been energized for a minimum of 12 hours.
- Verify all operating valves are open and service valves to atmosphere are closed.
- Verify supply air and control air pressure is available.

B. OPTIVIEW PANEL

To assure access to all setpoints, login at SERVICE access level before beginning. The setpoints are grouped under the display screen in which they appear. The indented screens are subscreens of the numbered screens and are accessed from the numbered screens. If any of the setpoints have to be changed, use the standard programming procedures in the *Operating Instructions (Form 160.72-O1)*. Thresholds, values and calibrations of items marked with an asterisk "*" are predetermined and entered/set at the YORK Factory at the time of manufacture.

1. EVAPORATOR Screen

Record the following setpoints:

Leaving Chilled Liquid Temp
 (except BAS remote mode).....

Leaving Chilled Liquid Temp Remote Range
 (except BAS remote mode).....

Leaving Chilled Liquid Temp Shutdown
 Temperature

Leaving Chilled Liquid Temp Shutdown
 Restart Temperature

Smart Freeze Protection On/Off

Refrigerant Temp Sensor Enable/Disable

2. CONDENSER Screen

Refrigerant Temp Sensor Enable/Disable

REFRIGERANT LEVEL CONTROL Screen

Record the following setpoints:

Control Valve Setpoint*

Manual or Auto Control (as desired)

3. COMPRESSOR Screen

Select Pre-rotation Vanes Manual or Auto
 control Mode (as desired)

HOT GAS BYPASS Screen:

If chiller is equipped with optional Hot Gas Bypass, enable operation on the OPERATIONS Screen and record the following setpoints:

Maximum Open

Hold Period

Close Percentage

Minimum Load

Manual or Auto Control (as desired)

INTERSTAGE VALVE Screen:

If chiller is equipped with an optional Interstage Valve(s), enable operation on the OPERATIONS Screen and record the following setpoints:

Control Valve Setpoint*

Manual or Auto Control (as desired)

4. MOTOR Screen:

Record the Current Limit Setpoint.....

CM-2 board:

- Verify Switch S1 (Ydelta/57% or all others) setting*
- Verify Pot R16 (LRA/FLA ratio setting*)
- Verify Slide Bar Resistor "RES" setting*
- Verify 105% FLA calibration*
- Verify 100% FLA display*

5. SETPOINTS Screen:

With the exception of the Remote Analog Input Range the setpoints listed on the SETPOINTS Screen have already been programmed above on Previous Screens. The values shown reflect the previously programmed values. However, the setpoints listed here can be changed on this screen if desired. This screen is used primarily as a central location from which most setpoints can be programmed. If it is not desired to change any of the listed setpoints, proceed to the SETUP Screen below.

Remote Analog Input Range.....

SETUP Screen:

- Enable Clock
- Enter Clock time and Date
- Select 12 or 24 hour display mode

OPERATIONS Screen:

- Select desired control source (operating mode); LOCAL, BAS Remote, DIGITAL Remote or ANALOG Remote

C. OPERATION

- Check evaporator and condenser water flows are reasonably close to design (+/-10%)
- Confirm oil temperature is in standby range
- Manually run the oil pumps and check oil pressures
- Jog compressor and check for correct rotation (caution-insure compressor and gear has good oil pressure prior to jogging and Pre-rotation Vanes are closed as indicated by position of the control arm).
- Start chiller
- After the chiller has come up to full load at design leaving chilled water temperature, log chiller operation

CHILLER STARTING AND STOPPING PROCEDURE

GENERAL

The compressor driveline supplied with each liquid chilling unit will vary due to application preferences and requirements. Refer to the driveline manufacturer's starting and operating instructions for procedures that must be completed before the unit can be started.

PRE-START COMPRESSOR CHECK

The following paragraphs describe the procedures prior to starting and operating a TURBOMASTER Compressor.



OIL HEATER

If the heater is de-energized during a shutdown period, it must be energized for 12 hours prior to starting the compressor or the compressor oil charge must be replaced with new oil.

1. Before actually starting the compressor, the following steps should be carefully checked.
 - (a) Check the compressor oil level (See CHECKING THE OIL LEVEL).
 - (b) Add new oil, if necessary.
 - (c) Completely open all shutoff water valves to the oil cooler. A full flow of water is required through the oil cooler at all times during starting and operation to inhibit foaming in the oil.
 - (d) Check the compressor oil sump temperature. The oil temperature must be a minimum of 10°F above the condenser saturation temperature (50°F if the unit has been shut down for less than 30 minutes) before the unit will be allowed to start.
 - (e) Open or adjust all shutoff valves necessary for the operation of the hot gas bypass and liquid injection systems and oil return systems
 - (f) Verify the compressor pre-rotation vanes are closed to unload the motor during starting.

CHECKING THE OIL LEVEL

Two oil level sight glasses are located on the oil sump end of the compressor. During operation the oil level should be visible in approximately the middle of the lower sight glass or ¼ of the upper sight glass, but should not fill the upper sight glass.

If the oil level is excessively high, the compressor may tend to lose some oil under starting conditions or conditions of rapidly changing load. In this case, oil may be drained from the compressor oil charging valve, while the unit is running.



Rapid withdrawal of oil will cause jet pump cavitation.

If the oil level is too low, pump cavitation and low oil pressure may occur. The machine will then shut down automatically and oil should be added to the compressor.

When the unit has been shut down for a prolonged period oil level above the top sight glass is normal.

UNIT START-UP

The following step-by-step procedure should be used to start-up the system (Refer to *Operating Instructions (Form 160.72-O1)* for OptiView™ Control Center Operating Instructions):

- 1. Set the Pre-Rotation Vanes Control to AUTO.
- 2. Set the Hot Gas Control to AUTO.
- 3. Set the Interstage Valve Control to AUTO.
- 4. Set the Subcooler Level Valve Control to AUTO.
- 5. Select the desired Control Source (LOCAL or ANALOG REMOTE).
- 6. Set the Leaving Chilled Liquid Temperature Setpoint.

- 7. Set the Current Limit Setpoint to 100% (unless a percentage is desired to limit maximum current).
- 8. Start the chilled water pump(s) and condenser water pump(s) and verify evaporator and condenser flow switches are made.
- 9. Reset any existing safety trips or power failures by moving the panel switch to the STOP/RESET (O) position and press the CLEAR MESSAGE button on the display. If all chiller safeties are satisfied the display will indicate READY TO START.
- 10. Move the panel switch to the START (◀) position. The switch is spring-loaded and will return to the RUN (■) position when released.
- 11. If a building automation system (BAS) is utilized to start and stop the chiller remotely via the System Cycling or Multi-Unit Cycling contacts, these contacts must be closed. A Cycling Shutdown message will appear on the display if the contacts are open.

The start sequence shall initiate. The display will indicate the operating state of the chiller as it transitions from start-up to run mode.

STOPPING UNIT

To stop the unit, proceed as follows:

- 1. Move the panel switch to the STOP/RESET (O) position or open the BAS Cycling contacts.
The chiller will shut down and the post-lubrication sequence will be initiated. The display will indicate that the unit is in COASTDOWN mode.
- 2. Shut down the chilled water pump(s) and condenser water pump(s).
- 3. Verify that the compressor oil sump heaters are energized.

NOTES

The following factors can be used to convert from English to the most common SI Metric values.

TABLE 8 - SI METRIC CONVERSION

MEASUREMENT	MULTIPLY ENGLISH UNIT	BY FACTOR	TO OBTAIN METRIC UNIT
Capacity	Tons Refrigerant Effect (ton)	3.516	Kilowatts (kW)
Power	Horsepower	0.7457	Kilowatts (kW)
Flow Rate	Gallons / Minute (gpm)	0.0631	Liters / Second (l/s)
Length	Feet (ft)	304.8	Meters (m)
	Inches (in)	25.4	Millimeters (mm)
Weight	Pounds (lbs)	0.4538	Kilograms (kg)
Velocity	Feet / Second (fps)	0.3048	Meters / Second (m/s)
Pressure Drop	Feet of Water (ft)	2.989	Kilopascals (kPa)
	Pounds / Square Inch (psi)	6.895	Kilopascals (kPa)

TEMPERATURE

To convert degrees Fahrenheit (°F) to degrees Celsius (°C), subtract 32° and multiply by 5/9 or 0.5556.

Example: $(45.0^{\circ}\text{F} - 32^{\circ}) \times 0.5556 = 27.2^{\circ}\text{C}$

To convert a temperature range (i.e., a range of 10°F) from Fahrenheit to Celsius, multiply by 5/9 or 0.5556.

Example: $10.0^{\circ}\text{F range} \times 0.5556 = 5.6^{\circ}\text{C range}$



BY JOHNSON CONTROLS

P.O. Box 1592, York, Pennsylvania USA 17405-1592
Copyright © by Johnson Controls 2010
Form 160.72-M1 (810)
Supersedes: Nothing

Tele. 800-861-1001
www.york.com

Subject to change without notice. Printed in USA
ALL RIGHTS RESERVED