

CONCRETE BASES

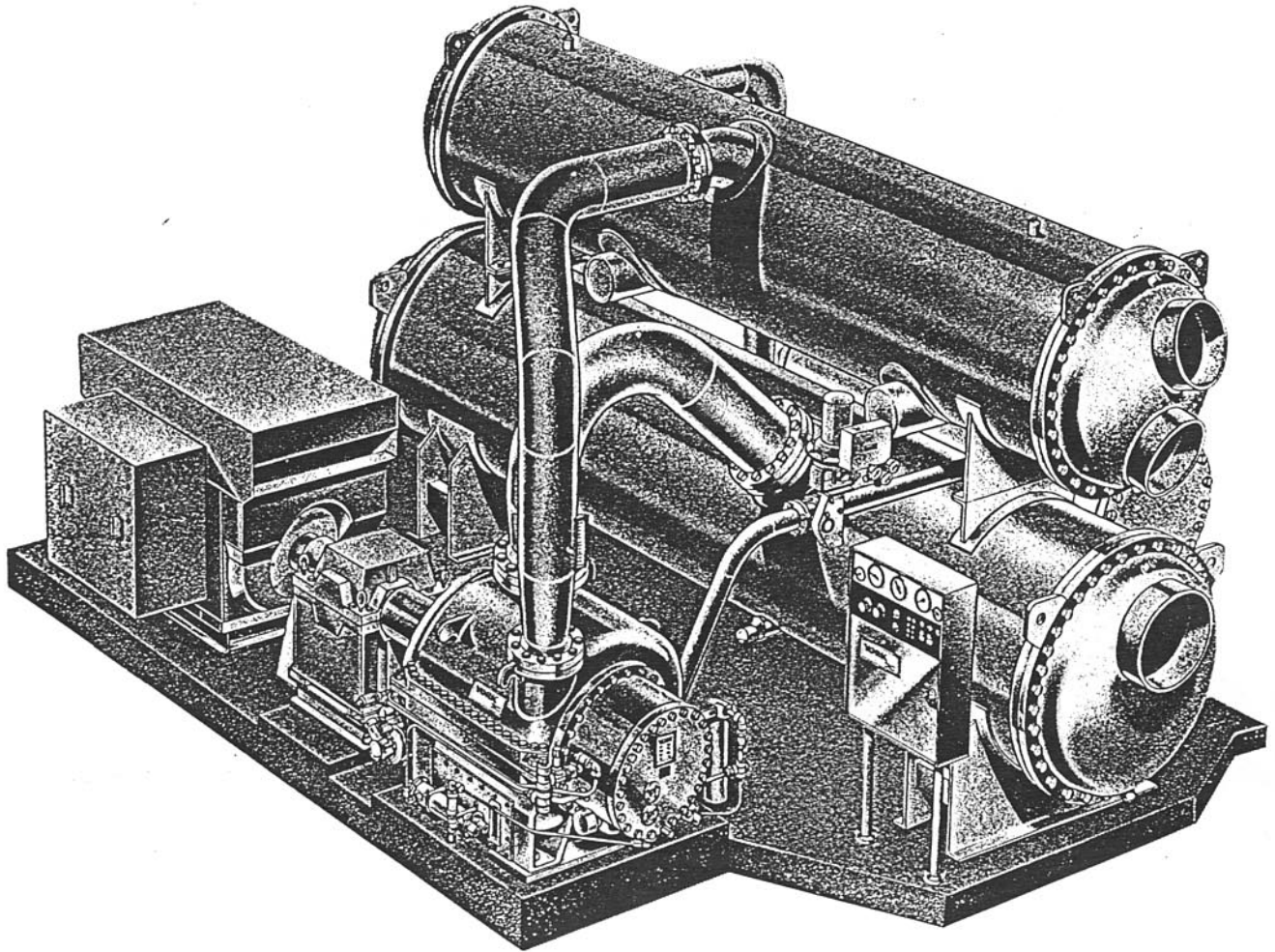

REFERENCE INSTRUCTION | INSTALLATION
FORM 160.72-N1

TABLE OF CONTENTS

CONCRETE BASES3

GENERAL.....3

CONCRETE BASE CONSTRUCTION – ROUGH LEVEL3

INSTALLATION OF COMPRESSOR AND DRIVE COMPONENTS6

INSTALLING COMPRESSOR ON CONCRETE BASE.....6

INSTALLING SPEED INCREASER.....6

INSTALLING ELECTRIC MOTOR7

INSTALLING STEAM TURBING7

GROUTING.....8

CONCRETE BASES

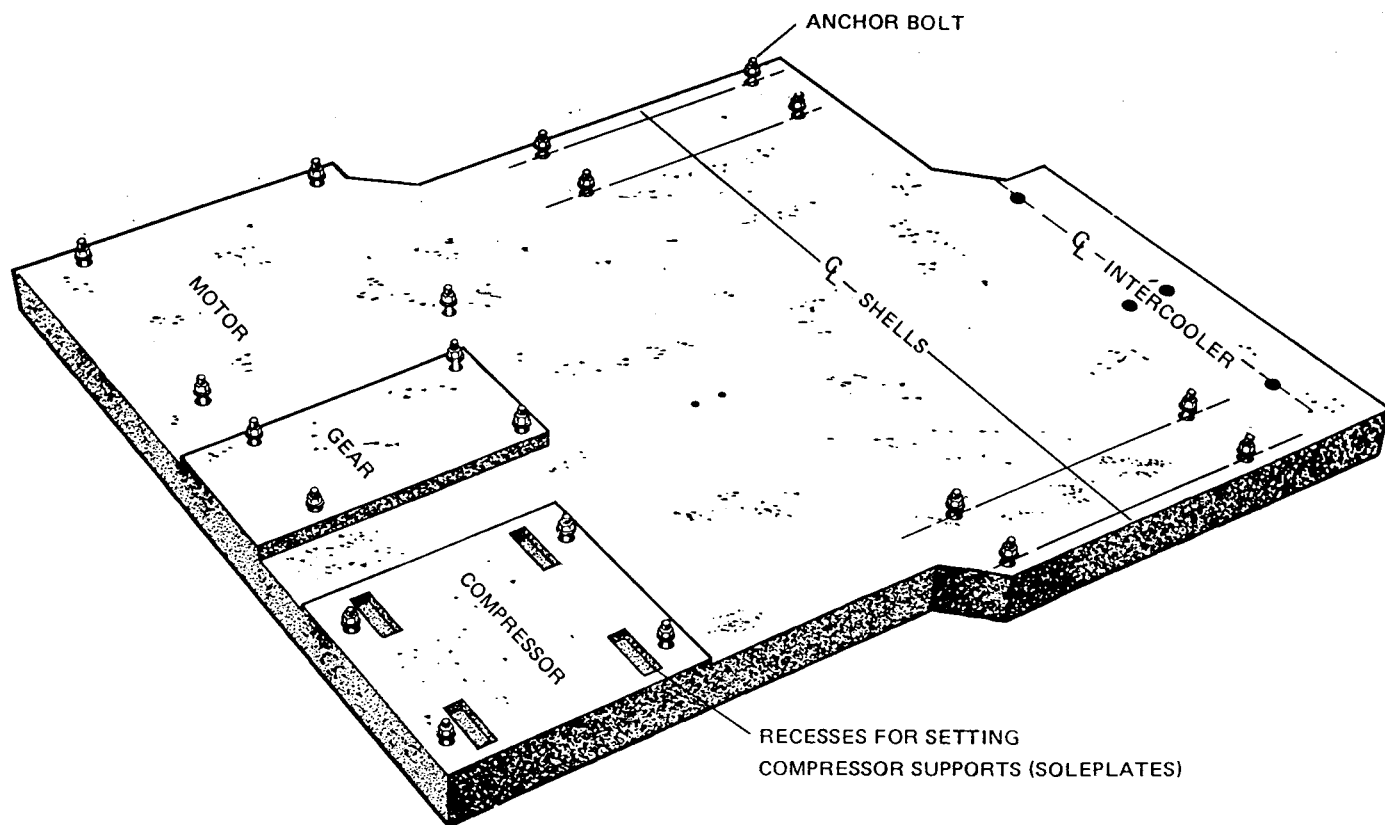

FIG 1 – TYPICAL REINFORCED CONCRETE BASE – ROUGH LEVEL

GENERAL

The standard base is built up of reinforced concrete construction with steel support plates and anchor bolts for mounting the major components of the unit (compressor, prime mover, cooler, condenser and speed increaser, if used). (See Fig. 1).

The purchaser must furnish a level foundation, or substructure of sufficient strength and rigidity to support the combined weight of the base and machinery.

Since the bases vary in size and contour to suit the machinery furnished for each installation, a certified drawing, showing the dimensions and details of base construction, is furnished for each installation. Actual structural and reinforcement design by others.

The purpose of this instruction is to supplement the certified base drawings by covering the procedures for constructing the rough reinforced concrete base.

NOTE: When constructing or erecting a base for a Turbo-master Unit follow the dimensions and notes on the final drawings carefully. Be sure all drawings are final drawings with firm dimensions from which the contractor designs the concrete base.

CONCRETE BASE CONSTRUCTION – ROUGH LEVEL

The concrete base consists of steel supports and anchor bolts for the cooler, compressor, prime mover and speed increaser (if used) all set into a solid block of reinforced concrete.

The steel supports, anchor bolts and anchor plates for the compressor, cooler, prime mover and speed increaser (if used) are furnished by the factory. The concrete and steel reinforcing rods are not furnished by YORK.

The concrete mixture should consist of the following parts (by volume) of cement, sand and crushed stone:

1. One part high grade cement.
2. Two parts clean, sharp sand.
3. Four parts crushed stone (small enough to pass through a 2" screen).

To construct a reinforced concrete base, refer to Figs. 1 to 3 inclusive and proceed as follows:

1. Refer to the certified drawings and lay out the dimensions of the base on the substructure. Be sure the base

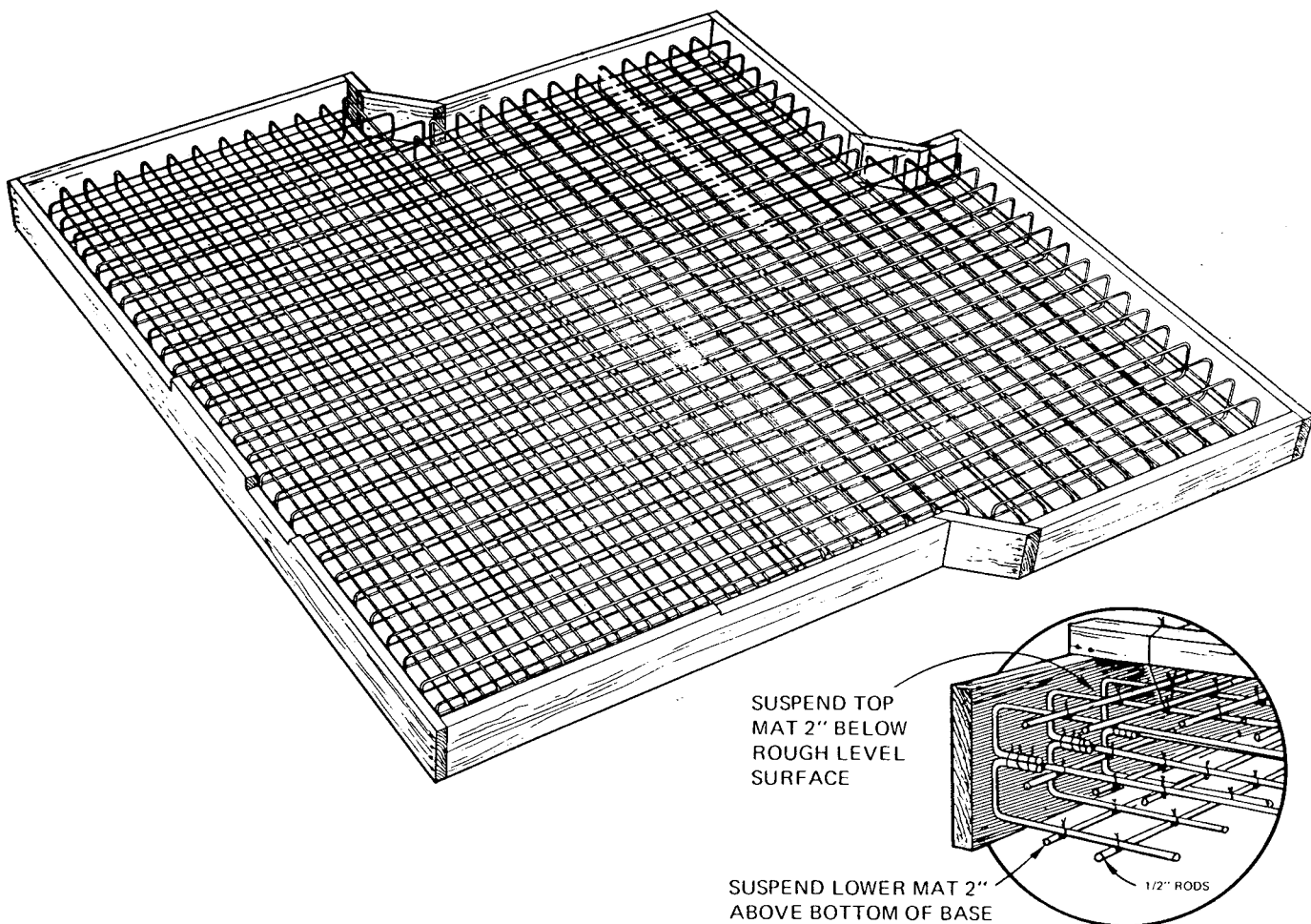

FIG 2 – TYPICAL STEEL REINFORCING ROD ARRANGEMENT (Design By Others)

dimensions are correct in accordance with the drawings furnished.

2. Build and set the wooden form required to pour the concrete base in accordance with the certified drawings. The inside length and width of the form should be the same as the outside length and width of the finished base. The height of the form should extend up to the grout line. Fig. 2 shows a typical form for a reinforced concrete base.

The wood form must be of good timber, properly braced and secured at the corners and elevation breaking points. The form must be diagonally braced against adjacent walls, or pilasters, to prevent the form from shifting when the concrete is poured.

3. Make up and suspend mats of reinforced rods in accordance with the certified drawings. The rods are to be spaced 6" apart and at right angles to each other. The ends of the lower mat are to be turned up and back to join the top mat per Fig. 2 detail, the rods must be wired together at each crossing and joint to prevent them from moving when the concrete is poured. Refer to Fig. 3, position the reinforcing rod mats as indicated on the

drawings by suspending the entire web with wires from 4" x 4" timbers placed across the wooden form. The top mat should be suspended 2" below the surface of the rough level and the lower mat should be positioned 2" above the floor line or top of substructure.

4. Refer to Fig. 3, attach a 2" x 4" block to each end of the strips which support the anchor bolts for the compressor. These blocks should be located under the compressor foot bolt locations to provide cavities in the concrete base for the angles which are welded to the bottom of the compressor supports. The blocks for these cavities should extend 2" beyond the width of the compressor supports, on each side, so that the supports do not cover the entire cavity. This provides an open hole at each side of the compressor supports through which to pour grout around the angles after the compressor is properly located on the rough level of the concrete base.
5. Make up the required number of properly sized sleeves, or ferrules, and accurately locate and suspend the anchor bolts in accordance with the certified drawings. The supporting strips for the anchor bolts should be fastened across the top of the wooden form as shown by Fig. 3. After the anchor bolts are suspended, recheck their locations with the certified drawings. Check all dimensions

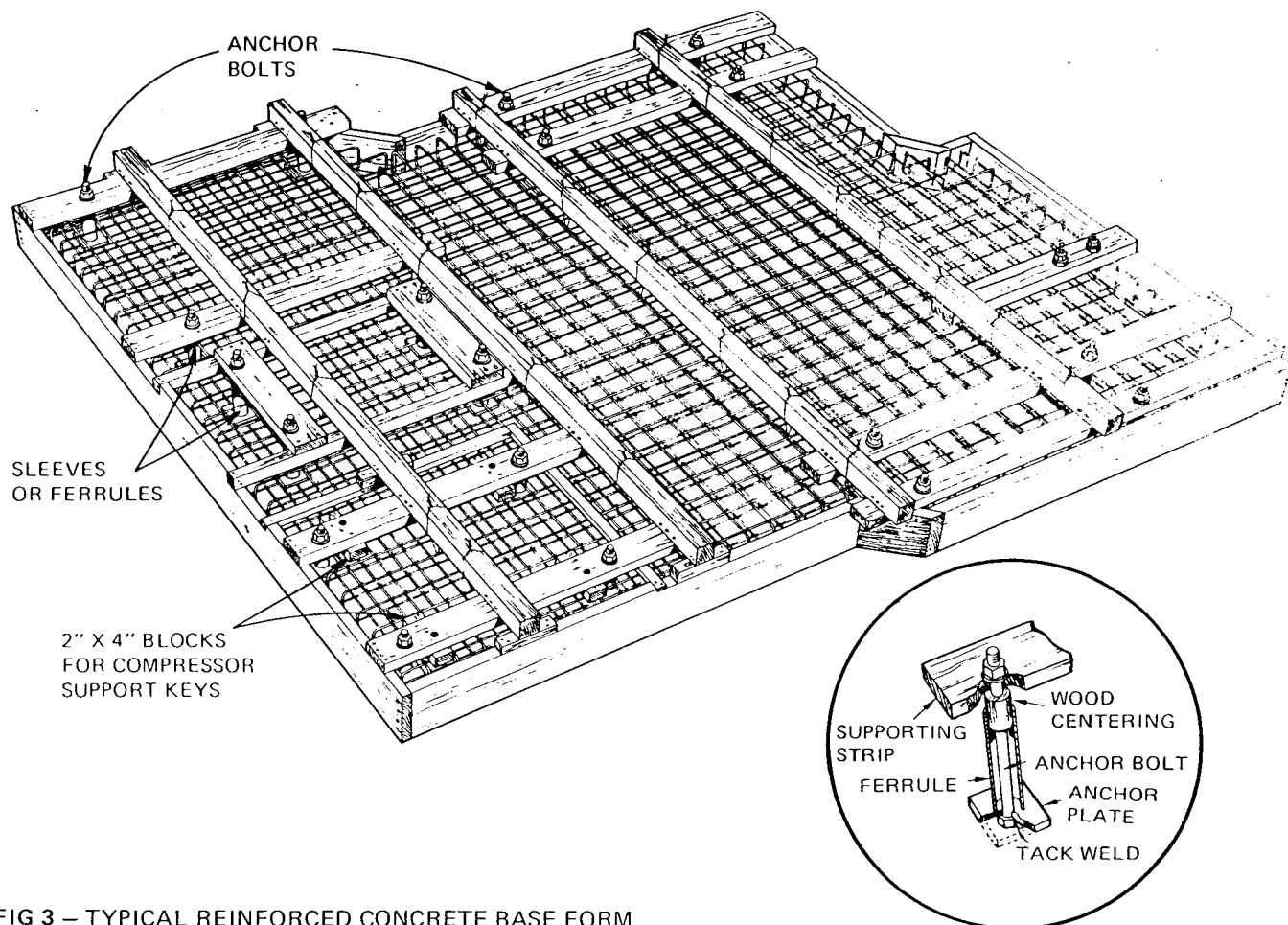

FIG 3 – TYPICAL REINFORCED CONCRETE BASE FORM

longitudinally, transversely and diagonally. Be sure to check the height of the anchor bolts and the distances between the center lines of the compressor, prime mover and cooler. (In accordance with Certified Drawings).

NOTE: The ferrules should be sized and located so that the top of each ferrule is flush with, or slightly above, the surface of the rough level so that concrete does not enter the ferrules. The ferrules must be blocked with a wooden centering plug so that the anchor bolts are centered within the ferrule when the concrete is poured. (See Fig. 3, Detail). This permits some movement of the anchor bolts for final alignment. After final alignment has been obtained, the grout should flow into the ferrules and lock the anchor bolts in position.

6. Be sure the form is adequately shored on the outside to prevent bulging. Then pour concrete until it has reached the rough level indicated on the certified drawing for the base. The upper surface should be rough so the final grout layer will form a good bond with the concrete already poured.

Fig. 1 shows a typical concrete base poured to the rough level, however the contours of these bases will vary to suit the equipment to be installed.

After the equipment is located and aligned on the rough base, the grout layer must be poured. (Refer to GROUTING, page 7.)

INSTALLATION OF COMPRESSOR AND DRIVE COMPONENTS

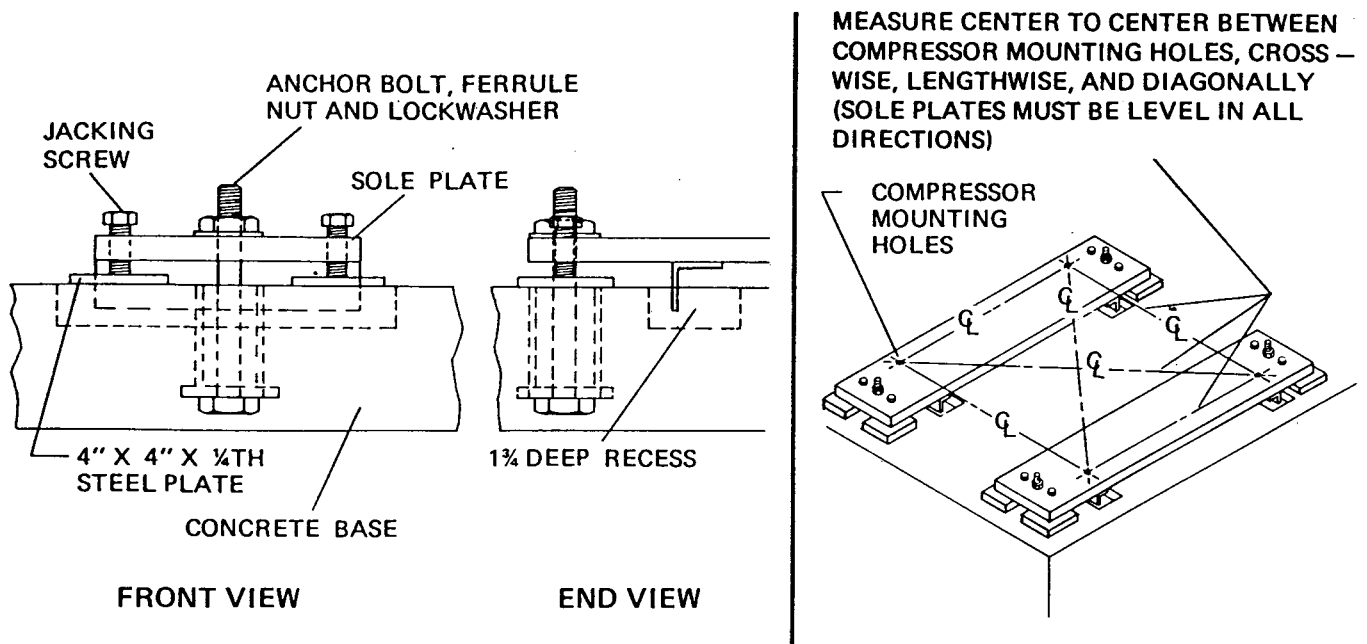

NOTE: All sole plates for other components must be installed with the same method.

FIG 4 –LOCATING AND ALIGNING SOLE PLATES

INSTALLING COMPRESSOR ON CONCRETE BASE

After the cooler, condenser and intercooler have been properly positioned, the compressor is to be mounted on the base. The compressor suction connection must be aligned with the suction line of the cooler.

Installing compressor supports (sole plates) (See Fig. 4).

1. Clean the compressor sole plates by removing all protective coatings from their surfaces.
2. Locate the 4" x 4" x 1/4" thick steel leveling plate at each point where the jackscrews will touch. (Each leveling plate should be centered under each jackscrew).
3. Install the jackscrews in the sole plate. But do not allow the screw to protrude below the bottom of plate. Allow approximately 1/8" inside the screw hole from the bottom of the sole plate.
4. Place the compressor supports (sole plates) over the anchor bolts. The angles on the bottom should extend down in to the recessed holes provided in the base. Level and align the sole plates with the jack screws in accordance with the Certified Drawings. Make sure the jackscrews bear on the 1/4" steel plates. Carefully check the dimensions from the centers of the compressor mounting bolt holes to the center lines on the base.

Measure the center to center distances between the compressor mounting bolt holes and check lengthwise crosswise and diagonally. (See Fig. 4). Draw the anchor bolt nuts snug, after supports have been leveled and aligned, to prevent the supports from shifting.

5. Protect surfaces of sole plates until the compressor is mounted.

INSTALLING THE SPEED INCREASER ON A CONCRETE BASE

If the compressor is to be driven by an electric motor, a speed increaser gear is located between the motor and compressor to produce the required speed of rotation. The low speed shaft of the speed increaser is on a common center line with the motor shaft and the high speed shaft is aligned to the compressor shaft.

To install the speed increaser supports (sole plates) proceed as follows:

1. Clean the speed increaser supports (sole plates), removing all protective coatings from their surfaces.
2. Locate and set the steel leveling plates at each point where the jackscrews will touch (each leveling plate should be centered under each jackscrew).
3. Level and align the supports in accordance with the certified assembly drawings and check the distances

between the mounting bolt holes crosswise and diagonally. (See Fig. 4). Draw the anchor bolt nuts snug to prevent the supports from shifting.

4. Set the speed increaser on its supports, using shims as necessary for leveling and raising the shafts to the proper elevation. Be sure to obtain the proper clearance between the compressor shaft and the end of the speed increaser output (high speed) shaft for coupling installation. See General Arrangement Drawing.

NOTE: Only approximate alignment can be obtained at this time. Final alignment cannot be made until the motor has been installed (See INSTALLATION AND FINAL ALIGNMENT OF FLEXIBLE COUPLINES, Form 160.71-N2, page 15).

INSTALLING THE ELECTRIC MOTOR ON A CONCRETE BASE

The electric motor should be mounted after the speed increaser is installed and approximately aligned. Since motors vary in construction (size and shape) the manufacturer's instructions must be followed for details. The motor must be mounted on its supports and aligned to the low speed shaft of the speed increaser.

To install the electric motor proceed as follows:

1. Set the steel motor supports in place on the rough level with the anchor bolts protruding through their holes in the supports.
2. Install the jackscrews in the supports and a steel plate on the rough level under each jackscrew.
3. Align the supports to the motor center line on the base. Measure the distance from the centers of the bolt holes to the center line on the base. Check the center to center distances between bolt holes crosswise and diagonally to be sure these distances are equal. (See Fig. 4).
4. Level the motor support sole plates lengthwise, crosswise and diagonally, adjusting the jackscrews as necessary. Be sure each jackscrew bears on a steel plate. Draw the anchor bolt nuts snug to prevent the supports from shifting.

5. Locate the motor on its supports and install the motor mounting bolts, using the shims as necessary to bring the motor shaft to the elevation of the low speed shaft of the speed increaser. Be sure to obtain the proper clearance between the ends of the motor shaft and the low speed shaft of the speed increaser. This distance must be checked with the assembly drawings when the low speed shaft is in the mid position of its end play and the motor is on its magnetic center.

INSTALLING THE STEAM TURBINE ON A CONCRETE BASE

If the compressor is to be driven by a steam turbine a speed increaser is usually not required, since the speed of the turbine is high enough to permit the turbine and compressor to be directly connected through a flexible coupling.

When installing a steam turbine the manufacturer's instructions and the assembly drawings should be carefully followed.

To install the steam turbine proceed as follows:

1. Set the steel turbine supports in place on the rough level with the anchor bolts protruding through their holes in the supports.
2. Install the jackscrews in the supports and a steel plate on the rough level under each jackscrew.
3. Align the supports to the turbine center line on the base. Measure the distance from the centers of the bolt holes to the center line on the base. Check the center to center distances between bolt holes crosswise and diagonally to be sure these distances are equal. (See Fig. 4).
4. Adjust the jackscrews as necessary. Be sure each jackscrew bears on a steel plate.
5. Locate the turbine on its supports and install the turbine mounting bolts, using shims as necessary to bring the shaft to the proper elevation.

NOTE: Final alignment should be done by the York Start-Up Engineer prior to initial start-up.

GROUTING

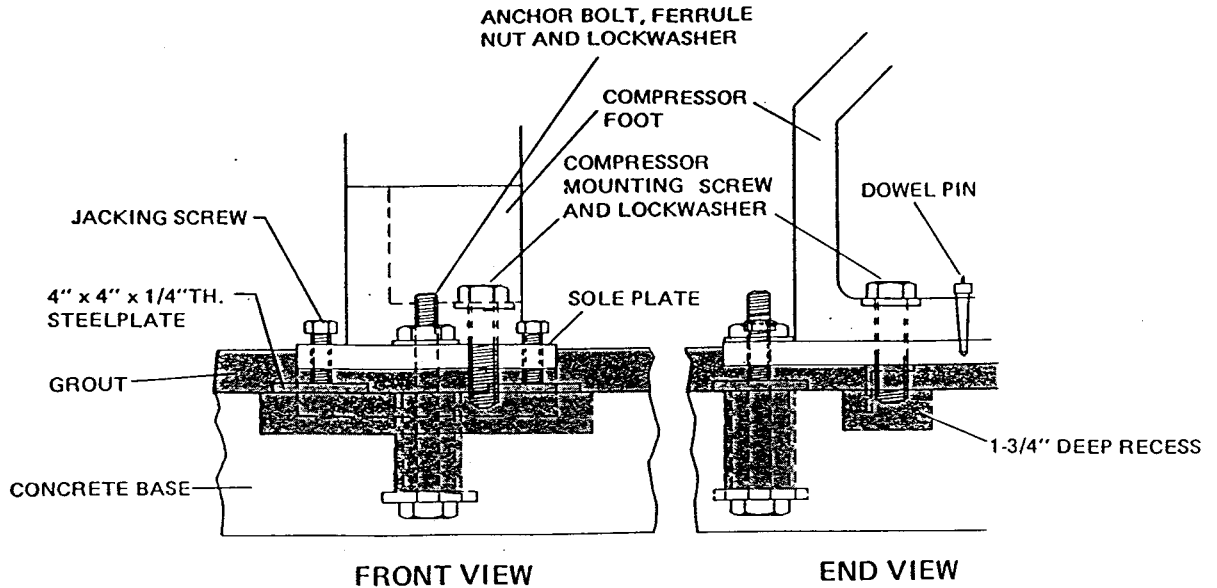

FIG 5 – COMPRESSOR MOUNTING WITH GROUTING POURED

GROUTING (for concrete base only)

After the components are located on the base and preliminary alignment has been obtained, the grout layer may be poured over the entire surface of the base in accordance with the drawings.

Before grouting, recheck the alignment of all components to make sure they are closely aligned. Grease jacking screws. The grout must flow down into the ferrules, around the anchor bolts, locking the anchor bolts securely in position. A slight clearance at the mounting bolt holes will allow some adjustment for final alignment. However, major adjustments must be made before grouting, while the anchor bolts are free to move from side to side. To pour the grout layer, refer to the drawings for the base and proceed as follows:

1. Thoroughly wash down the surface of the rough level to insure a good bond between the rough surface and the grout layer.
2. Build a form around the top of the base. The top of the form should be level with the top of the grout level as indicated on the drawings usually 1" above the rough level.
3. Mix a sufficient quantity of grout (an expansion type epoxy grout must be used. Two acceptable grouts are Master Builders 636 and Celicote HT 648. Follow the manufacturers recommendations for setting, precautions, mixing working time, grout placement, finishing and curing.

4. Pour grout on the rough level surface to the elevation indicated on the drawings. With a stiff wire, work the grout under the supports for the cooler, compressor and drive. With a wire, work the grout around the keys under the compressor supports. The grout must fill the space around the compressor support keys. Grout should be poured under the supports from one side only until it flows out the opposite side. This minimizes the possibility of air pockets which might form if grout is poured under the supports from both sides.

The grout must flow into the ferrules around the anchor bolts and fill the space under the supports and cooler feet so that it forms as a solid surface capable of supporting the weight of the machinery.

5. Allow at least 48 hours for the grout to set and harden. Then remove the jack screws and tighten the anchor bolts securely.

NOTE: It is important to remove the jack screws before tightening the anchor bolts since the weight of the machinery should be supported by the grout, not by the jack screws.

6. Finish the top and sides of the base, as indicated on the drawings, using a mixture of one part Portland cement, two parts clean, sharp sand and enough water to permit proper troweling.

FOR PIPING, CONTROLS, AND INSULATION, ETC. REFER TO INSTALLATION INSTRUCTION – FORM 160.71-N1.



Proud Sponsor
of the 1998
U.S. Olympic Team

36USC380