



## 1. CONTENTS.

Page	Section
1	1. Contents
2	2. Installation -
	2.1 Direct Mounting Units onto Kinetrol Positioner Actuators
	2.2 Mounting of Discrete Positioners.
3	2.3 Air and Electrical Connections.
4	3. Description of Operation
5	4. Settings and Adjustments –
6	4.1 Change of Direction for rising signal (direct mounted)
	4.2 Zero and Range Adjustment
	4.3 Speed Control
	4.4 Change of Direction for rising signal (Discrete)
7	5. Maintenance and Troubleshooting
8-10	6. Angle Retransmit Option –
	6.1 Installation
	6.2 Change of Direction for rising signal
	6.3 Zero and Range Adjustment
	6.4 Change of Direction for rising signal (Discrete)
	6.5 Change of Angle Retransmit direction without changing positioner direction.
11-13	7. Spare Parts -
	7.1 Exploded View
	7.2 Spare Part Numbers



## 2. INSTALLATION.

Positioners can be supplied direct-mounted, or ready to be direct-mounted, onto Kinetrol rotary actuators, or in stand-alone (discrete) form for fitting via a mount kit to any 90 degree rotary or linear actuator. If the positioner is supplied ready mounted on an actuator, sections 2.1 & 2.2 can be bypassed. Positioner-type Kinetrol actuators (ready for direct mount of positioners) are available in models 050 to 140 inclusive.

### 2.1 Mounting of Direct Mounting Units onto Kinetrol Positioner-Type Actuators (without angle retransmit)

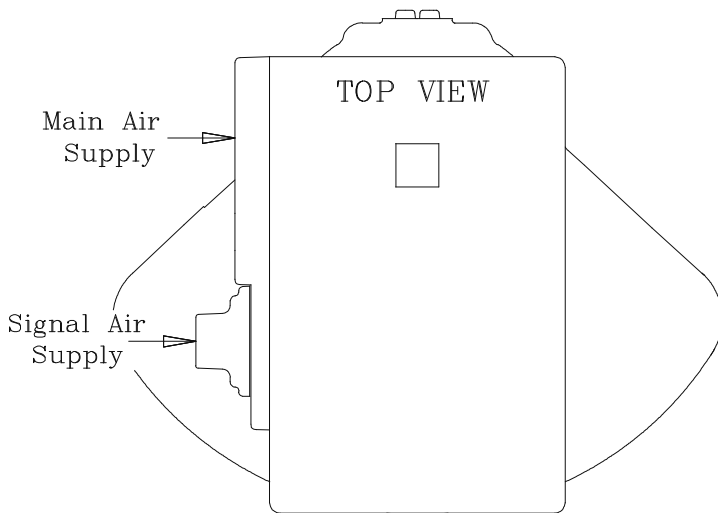

Figure 1. Mid Travel Orientation of Actuator Square and Positioner Box

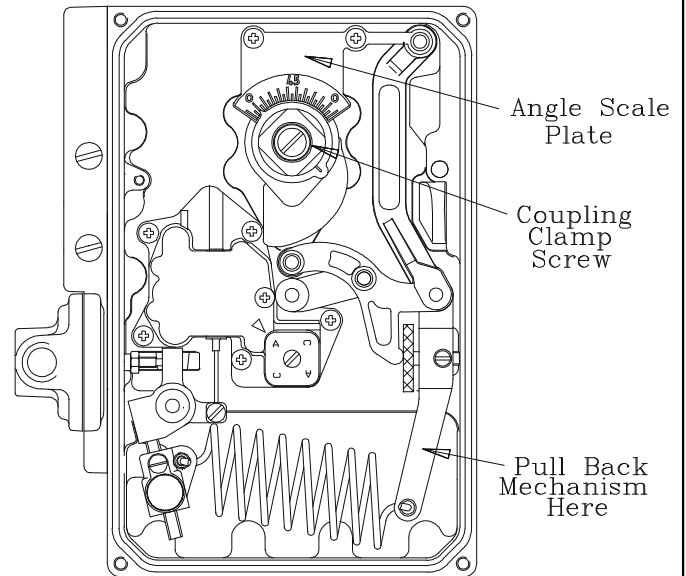

Figure 2. View of inside of Positioner Box Showing Parts for Removal During Installation.

**Note: For angle retransmit versions, refer to section 6.1**

2.1.1 Move actuator vane to mid travel position, with its output square as shown in Figure 1. This is advisable to prevent subsequent error in orientating positioner coupling. (This is not necessary with spring return actuators as there can be no confusion with square orientation).

2.1.2 Remove positioner cover and undo the two M4 screws retaining the red angle scale plate and remove coupling as shown in Figure 2.

2.1.3 Bolt the positioner body to the actuator in the orientation shown in Figure 1 taking care that the two O'rings are in place to seal the ports to the actuator (place a small amount of grease onto the O'rings to keep them in place) and that the actuator shaft is centred in the body.

2.1.4 Observe the direction that the cam moves with a rising signal and, if correct, place the coupling on the actuator square with one hand whilst pulling back the mechanism with the other (refer to Figure 2). If the direction is not as required then refer to section 4.1. If the actuator has been correctly positioned near mid-stroke, the cam follower will contact the cam at approximately half way. Ensure that the coupling is pushed fully onto the actuator square and tighten the central fixing screw which will have the effect of centralising the cam follower on cam. Refit the angle scale plate.

### 2.2 Mounting of Discrete Positioner.

The design and manufacture of the mount kit between the positioner and actuator is outside the scope of this document. It is essential that the shaft of the actuator is well aligned with the positioner shaft and that the two are coupled together with a minimum of backlash as this will reduce the performance of the positioner/actuator combination.

It is essential that the 90 degree travel of the actuator moves the positioner coupling through the correct 90 degrees of travel. This can be achieved by either observing the position of the indicator on the lid or the position of the cam or internal indicator with the lid removed.



**2.3 Pneumatic and Electrical Connections.**

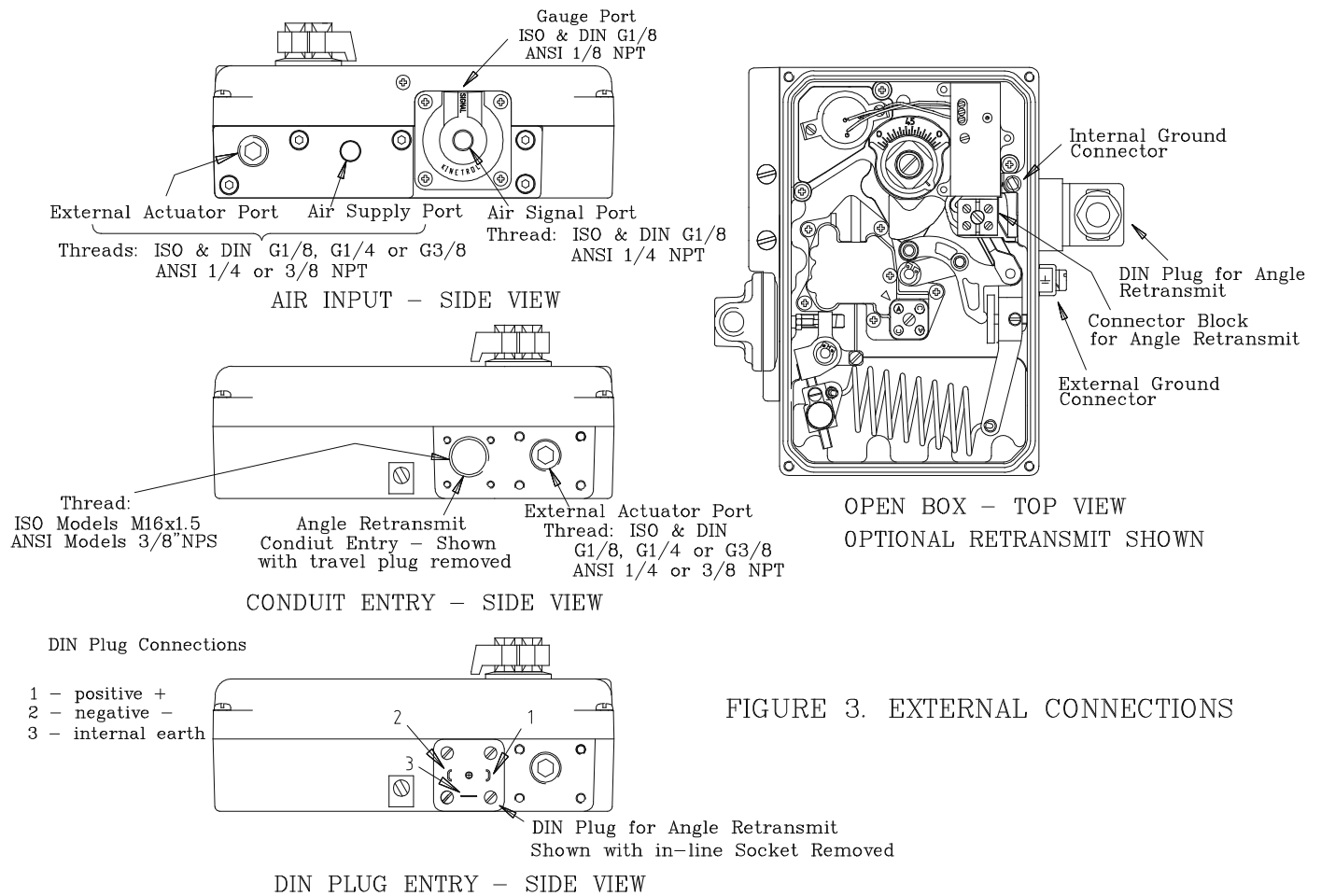

FIGURE 3. EXTERNAL CONNECTIONS

**2.3.1 Air Supply**

Connect main air supply (pressure between 3.5 and 7 bar or 50 and 100psi) to the supply port indicated in figure 3. Also connect signal air supply (pressure between 0.2 bar and 1 bar or 3 psi and 15 psi) to the inlet of the diaphragm housing. It is important that the air is clean, dry and oil free. Quality class 6.4.4 (taken from ISO standard 8573.2001) is adequate. This implies 5 micron max. Particle size, 3 deg. C dew point max. and 5mg per cubic metre max. oil content.

**2.3.2 Angle Retransmit Option Supply.**

The optional angle retransmit circuit is loop powered, requiring 8 to 30 volts to drive the 4-20mA current through it. The current which passes is linearly in proportion to the shaft angle.

The cable entry has the option of a cable gland fitting or 4-way DIN plug. With the cable gland entry the wires are directly connected to the internal Connector Block. An internal earth connection is provided if required. If the DIN plug option is fitted then the internal connections have already been made as shown in Figure 3. An external earth connection is also provided if this is required.

**2.3.3 External Actuator Ports.**

For positioners not fitted directly onto Kinetrol Positioner type Actuators, two external ports are provided for connecting the positioner outlets to the actuator. The size of the ports is dependant on the positioner ordering code. These ports can also be used for fitting pressure gauges if desired.



### 3. DESCRIPTION OF OPERATION.

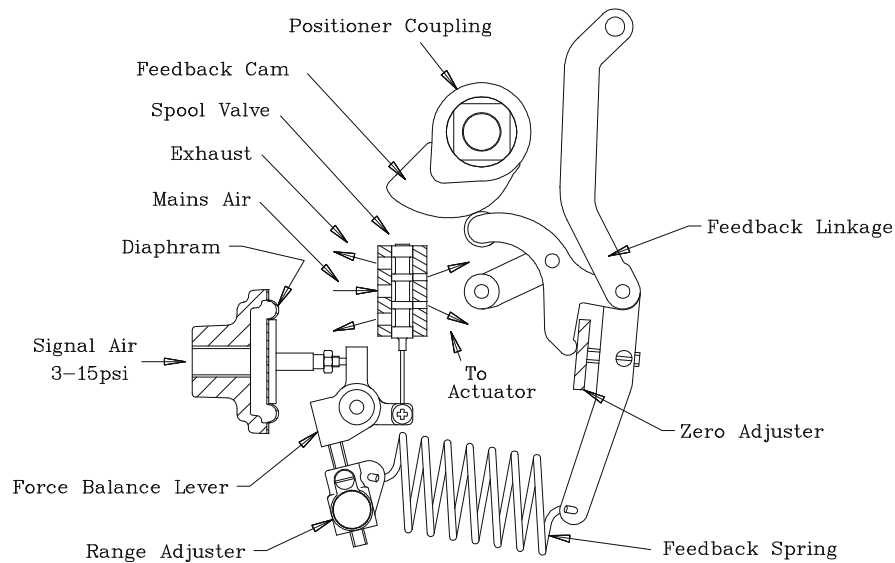

FIGURE 4. PRINCIPAL OF OPERATION.

The AP Positioner works using the principal of a 'force balance' spool system with mechanical cam feedback. The air input signal (normally 3-15psi) is applied to a diaphragm which produces a force on the force balance lever which is proportional to the signal pressure. The resulting torque on the lever is balanced by the force produced from the feedback spring which is also joined to the lever.

A proportional flow spool valve is the third element attached to the lever. This is positioned at its central closed position when the lever is at the mid-stroke position which occurs when the actuator is at the desired angle. Several different versions of this valve are available with different flow capacities designed to give optimum performance when fitted to the range of Kinetrol actuators.

The feedback cam is retained by a coupling which, in the case of a Kinetrol direct mounted positioner, is held onto the vane square by a collet. For discrete versions, the coupling is retained in bearings and connected by either a male square or 'Namur' style connector.

The cam provides positional feedback via a unique four bar linkage which ensures a linear movement of the cam follower whether the cam is set for clockwise or anticlockwise movement for a rising signal. The lower part of the linkage is attached to the other end of the feedback spring which stretches the spring as the cam is rotated to produce the feedback force mentioned earlier. The standard cam produces a linear characteristic, but alternative profiles are available.

The common adjustments are split into zero and range. Both are achieved without the need for special tools and the actual adjustments are made using finger pressure only.

Air passages in the main body are provided with the capability of many options with a minimum of changes. External ports are provided on all models to allow for external connection to the actuator or for the fitting of pressure gauges if desired. Three main air flow options are available (as detailed in the AP literature). The two lower flow rate options (AP & MP) are affected by change of valve size and tapping size in the body. The largest flow rate option (HP) not only has a larger valve but also a different port plate with 3/8 tapping and external combination silencer/snubbers.

The mounting options are accommodated by three different channel plate designs. The channel plate is the plate fitted to the base of the unit. The smallest is dedicated to direct mounting on an 050 Actuator. The second is used for direct mounting on Actuators 070 to 140. The third is used for discrete models having a Namur mounting hole pattern.

An optional angle retransmit can be fitted within the positioner body and additional options of I/P controller and limit switch box can also be fitted allowing a wide range of switch options to be specified.



#### 4. SETTINGS AND ADJUSTMENTS.

The positioner will have been factory set to the requirements given in the ordering code ( i.e. the direction of rotation for a rising pressure signal and the range and zero settings). However, if these settings need to be changed, the following section describes the procedure for achieving this.

##### 4.1 Change of Direction for Rising Signal (direct mounting units only).

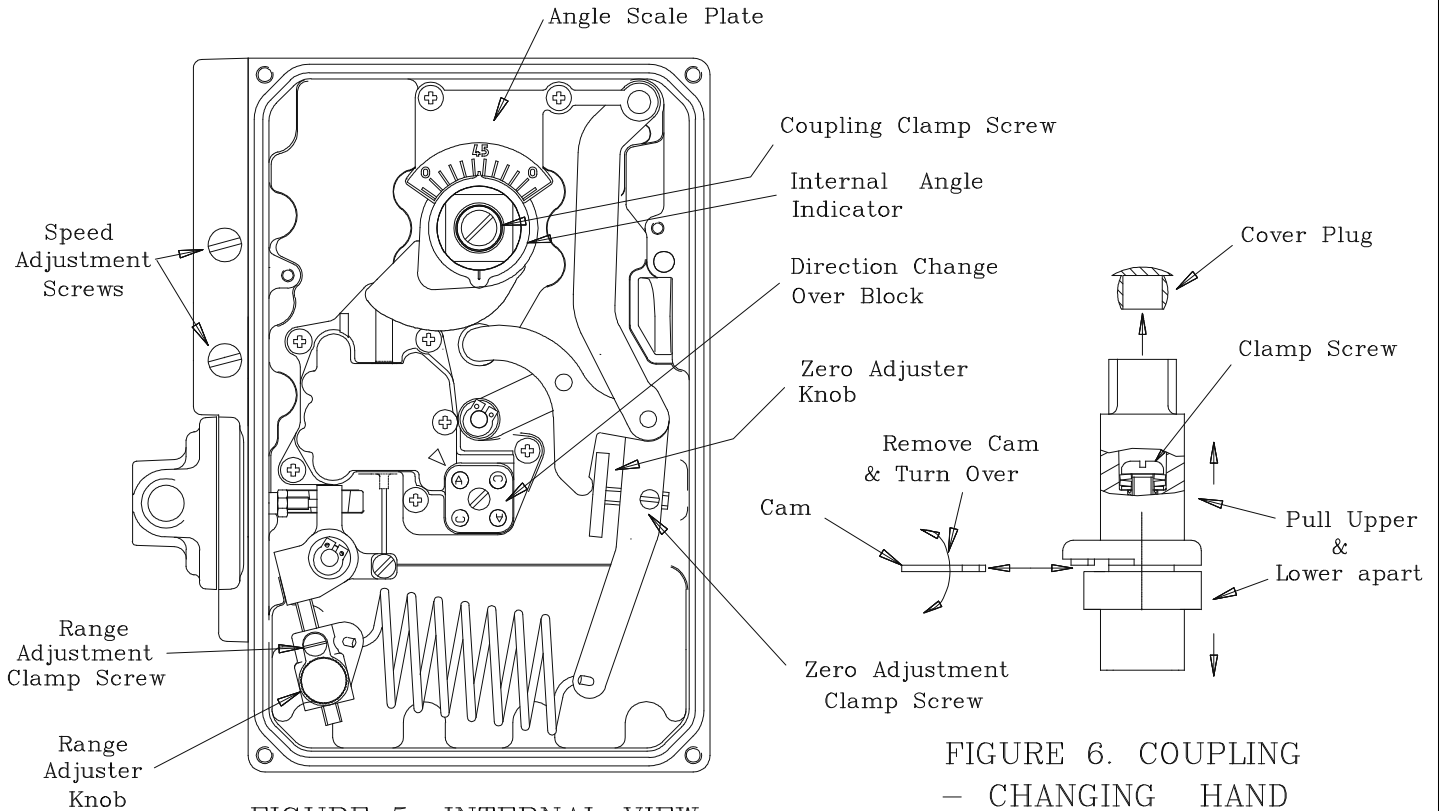

FIGURE 5. INTERNAL VIEW

FIGURE 6. COUPLING – CHANGING HAND

4.1.1 Move the actuator to approximately mid-position to avoid problems in correct orientation later. This is obviously not possible or necessary with spring return models because the position of the vane will be known. Reduce both main supply and signal pressures to zero.

4.1.2 Remove positioner cover and undo the two M4 screws retaining the red angle scale plate and remove, as shown in Figure 5. Loosen the central coupling screw sufficiently to draw the coupling off the actuator square.

4.1.3 Pull the two halves of the coupling apart sufficiently to allow the cam to be withdrawn from its location peg as shown in Figure 6. Flip the cam over and push it back into the slot between the two coupling halves and locate it back on the peg.

4.1.4 If when the coupling was removed, the collet was left behind on the actuator square, remove the collet from the square and push it into the lower half of the coupling ensuring that it locates in the semicircular 'pip'. Tighten the clamping screw by two turns before placing it back on the actuator square such that the cam follower is approximately half way up the rise of the cam and tighten the clamping screw. Replace the angle scale plate.

4.1.5 Undo the changeover block central screw and rotate it by a quarter turn and replace and tighten screw. For your convenience, the changeover block is marked 'A' and 'C' which refers to 'anticlockwise' and 'clockwise' respectively. Ensure the required letter is placed opposite the arrow marked on the top of the valve block.



## 4.2 Zero and Range Adjustment (refer to Figure 4).

4.2.1 Move the actuator/positioner to the zero end of the stroke (i.e. when the cam follower is at the beginning of its rise). This can be most easily achieved by pressurising the main air supply without any signal air pressure (spring return models will already be at this position). Exhaust the supply air and move the internal indicator to indicate just below zero on the angle scale.

4.2.2 Set the coarse zero by slackening the coupling screw by approximately half of a turn until the top part of the coupling can be rotated by hand and rotate until the cam follower just starts to rise up the cam profile. Retighten the screw.

4.2.3 Turn on the main air supply and carefully increase the signal supply pressure to 3psi (0.2Bar). Slacken the fine zero adjustment clamp screw and rotate zero adjuster using thumb pressure so that the actuator moves to indicate zero on the internal indicator. Tighten clamp screw.

4.2.4 Increase the signal pressure to 15psi (1 Bar). Slacken the range adjuster clamp screw and rotate the adjuster knob between thumb and forefinger until the actuator moves to the desired end stroke position (normally 90 degrees) as indicated on the internal indicator. Re-tighten the clamp screw.

4.2.5 Reduce the signal air pressure again to 3 psi and check that the zero position has not changed.

## 4.3 Speed Control.

Maximum actuator speed can be regulated by the two following methods:

a.) Changing the valve spool/liner size. The valve size is normally specified at the point of ordering by the letters 'AP', 'MP' or 'HP'. This method, however, not only effects the actuator speed but also effects the 'gain' and therefore control stability of the unit and care must be taken not to specify a too high flow valve for a given size of actuator. Kinetrol Ltd has recommendations (shown in the AP literature) for each size of the actuator

or

b.) adjustment of the built in flow restrictors (shown in Figure 4) is achieved using a screwdriver. There are two restrictors, one for each direction of travel. Clockwise rotation, this will reduce the actuator speed. 'AP' and 'MP' size units with 1/8 or 1/4 ports are controlled in this way but 'HP' size units having 3/8 ports are fitted with external silencer/restrictors which are adjusted using an allen key fitted down the centre of the adjuster.

## 4.4 Change of Direction for Rising Signal (discrete units).

4.4.1 Move actuator as in Section 4.1.1.

4.4.2 Remove positioner cover and undo the three M4 screws retaining the red retransmit plate, as shown in Figure 7. Loosen the central coupling screw sufficiently to pull the coupling complete with the retransmit assembly off the actuator connection.

4.4.3 Remove the internal indicator from the coupling and withdraw the coupling from the retransmit plate.

4.4.4 Pull the two halves of the coupling apart sufficiently to allow the cam to be withdrawn from its location peg. Flip the cam over and push it back into the slot between the two coupling halves and locate it back on the peg.

4.4.5 Refit the coupling to the retransmit plate and slide the internal indicator over the top of the coupling.

4.4.6 If when the coupling was removed, the collet was left behind on the actuator connection, remove the collet from the connection and push it into the lower half of the coupling ensuring that it locates in the semicircular 'pip' and tighten the clamping screw by two turns. Place the coupling and retransmit plate back on the actuator connection such that the cam follower is approximately half way up the rise of the cam and pull back the spring lever with the other hand and tighten the coupling clamping screw. Re-tighten the retransmit plate retaining screws.

4.4.7 The internal changeover block is not effective with a discrete positioner. The changeover of the airflow path is achieved by swapping over the external connections. It may also be preferred to turn the positioner through 180 degrees to simplify the external pipe runs.

4.4.8 The adjustment of zero and range is completed as in section 4.2.



**5. MAINTENANCE AND TROUBLESHOOTING.**

The AP positioner is designed for a long life with very little maintenance required if it is supplied with clean, dry oil free air, as recommended in section 2.3.

When the positioner lid is removed, take care not to remove all grease from the lid/coupling seal. If it does need replenishing then ensure that a synthetic grease is used as a mineral oil grease will adversely affect this seal.

If, however, any of the parts do need replacement because of adverse conditions, then refer to Kinetrol Ltd for spare parts together with any instructions for replacing and resetting.

The following trouble shooting guide should help in the unlikely event of a problem with the performance of the unit. If problems persist, contact your local Kinetrol distributor or Kinetrol Ltd for further advice.

**TABLE 1. Troubleshooting Guide**

Failure to move when signal air and mains air is applied

- Check mains air pressure is sufficient to produce enough torque from actuator
- Check signal pressure using pressure gauge in gauge port or check that the force balance lever is being pushed by the input diaphragm with the lid removed
- Has the coupling been positioned at the correct angular position on the actuator?
- Has the changeover block been set correctly for the direction of rotation (direct mounted units) or the external port connections been fitted the correct way around (discrete units)?
- Is the air quality poor, causing the spool to jam? This can be checked by manually moving the spool carefully by hand with the lid removed.
- Is the actuator or whatever it is connected to jammed? This can be checked by again moving the force balance lever manually to check if the actuator responds (air will normally be heard hissing into the actuator when this is done).

Actuator moves too slowly upscale or down scale:

- Is the mains air pressure too low for the load being moved or the actuator too small?
- Have one or both flow adjuster screws been screwed in too far?
- Is the air contaminated causing the spool movement to become sluggish?
- Is the actuator volume too large for the spool flow rate chosen?

Lack of sensitivity:

- Is the spool sticky, caused by a contaminated air supply?
- Does the actuator exhibit poor stick slip qualities? This may be especially true if it is not Kinetrol and will normally be seen also as a jerky movement.

Excessive Hysteresis:

- Has the inside of the positioner box become contaminated causing the force balance mechanism bearings to become sticky?
- Is the actuator load excessive causing it to struggle to achieve position?

Overshoot/Instability:

- Is the spool valve chosen too large for the size of the actuator?
- Is the inertia loading too great for the size of actuator chosen? Refer to Kinetrol for allowable limits.
- Have the snubbers been used to slow the load down?



## 6. ANGLE RETRANSMIT OPTION.

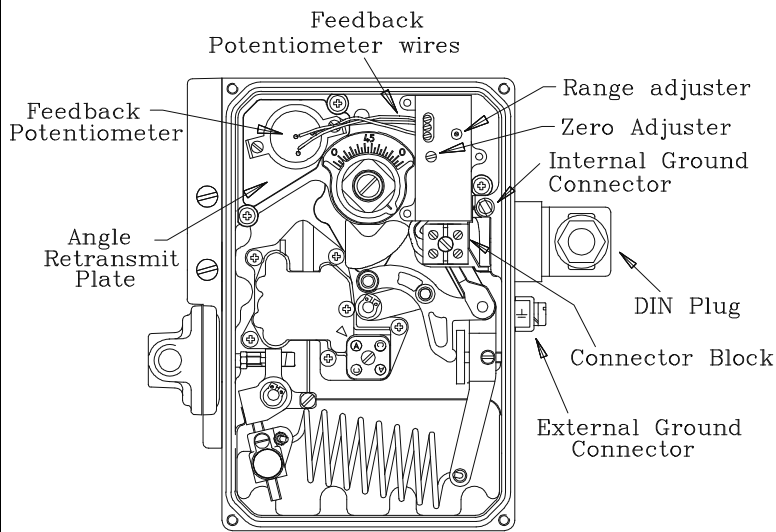

FIGURE 7. ANGLE RETRANSMIT.

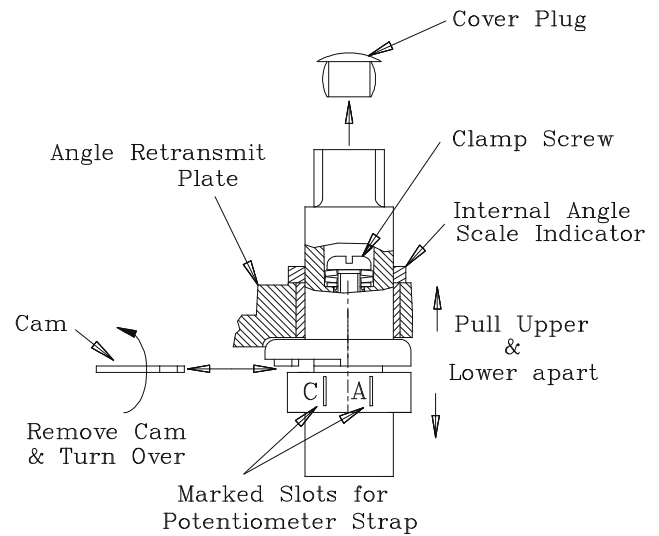

FIGURE 8. COUPLING  
– CHANGING HAND

6.1.1 Move actuator vane to mid travel position, with its output square as shown in Figure 1. This is advisable to prevent subsequent error in orientating positioner coupling. (This is not necessary with spring return actuators as there can be no confusion with square orientation).

6.1.2 Remove positioner cover and unscrew the three M4 screws retaining the red retransmit plate, release the two wires on the terminal block connected to the DIN plug (if fitted), as shown in Figure 7, and carefully remove coupling and retransmit assembly as one unit.

6.1.3 Bolt the positioner body to the actuator in the orientation shown in Figure 1 taking care that the two O'rings are in place to seal the ports to the actuator (place a small amount of grease on to the O'rings to keep them in place) and that the actuator shaft is centred in the hole in the body.

6.1.4 Observe the direction that the cam moves with a rising signal and that the retransmit strap is fitted to the correct slot in the lower coupling as marked (C & A for clockwise and anticlockwise respectively). If the direction is not as required then refer to section 6.2. If correct, place the coupling and retransmit assembly on the actuator square with one hand whilst pulling back the mechanism and two DIN plug wires with the other (refer to Figure 6). If the actuator has been correctly positioned near mid-stroke, the cam follower will contact the cam as approximately half way.

6.1.5 Ensure that the coupling is pushed fully on to the actuator square and tighten the central fixing screw which will have the effect of centralising the cam follower on the cam track. Retighten the three angle retransmit retaining screws and refit the two DIN plug wires (if fitted).

### 6.2 Change of Direction for Rising Signal (direct mounting units only).

6.2.1 Move the actuator to approximately mid-position to avoid problems in correct orientation later. This is obviously not possible or necessary with spring return models because the position of the vane will be known. Reduce both main supply and signal pressures to zero.

6.2.2 Remove positioner cover and undo the three M4 screws retaining the red retransmit plate, release the two wires on the terminal block connected to the DIN plug (if fitted), as shown in figure 7. Loosen the central coupling screw sufficiently to carefully pull the coupling complete with the retransmit assembly off the actuator square.

6.2.3 Release the potentiometer strap from the slot in the lower coupling, as shown in figure 8, remove the internal indicator from the coupling and withdraw the coupling from the retransmit plate.



6.2.4 Pull the two halves of the coupling apart sufficiently to allow the cam to be withdrawn from its location peg. Flip the cam over and push it back into the slot between the two coupling halves and locate it back on the peg.

6.2.5 Refit the coupling to the retransmit plate, slide the internal indicator over the top of the coupling and refit the potentiometer strap into one of the two marked slots of the lower coupling (marked 'A' and 'C' for anticlockwise and clockwise movement respectively).

6.2.6 If when the coupling was removed, the collet was left behind on the actuator square, remove the collet from the square and push it into the lower half of the coupling ensuring that it locates in the semicircular 'pip' and tighten the clamping screw by two turns. Place the coupling and retransmit assembly back on the actuator square so that the cam follower is approximately half way up the rise of the cam whilst holding back the two retransmit wires and pull back the spring lever with the other hand and tighten the coupling clamping screw. Re-tighten the retransmit plate retaining screws and refit the retransmit wires to the terminal block.

6.2.7 To ensure a rise in retransmit signal with rising input pressure signal, the top and bottom wires on the feedback potentiometer must be reversed in the connector located on the circuit. The central wire does not change.

6.2.8 Undo the changeover block central screw and rotate it by a quarter turn and replace and tighten screw. The changeover block is marked 'A' and 'C' which refers to 'anti-clockwise' and 'clockwise' respectively. Ensure the required letter is placed opposite the arrow marked on the top of the valve block.

### 6.3 Zero and Range Adjustment (refer to Figure 7).

Setting of the mechanical zero and range for the positioner with an angle retransmit is the same as described in section 4.2. The retransmit circuit must also be set for zero and range which is described below.

6.3.1 Set the circuit zero adjustment to the central position and connect a 4-20ma electrical source via the DIN plug or terminal block.

6.3.2 Set the positioner to zero degrees or the input pressure to 3 psi (0.2 Bar)

6.3.3 Slacken the two screws which clamp the potentiometer to the retransmit plate but do not remove. Rotate the potentiometer slowly using finger pressure until the electrical display shows 4ma.

6.3.4 Increase the air signal pressure to 15 psi (1 Bar) to set the positioner at 90 degrees. Adjust the Span potentiometer to read 20ma.

6.3.5 Repeat steps 6.3.2 to 6.3.4 until the desired readings are obtained at both ends of the stroke. The fine zero potentiometer can be used to obtain a more precise reading at the zero position.

6.3.6 Tighten the two potentiometer clamp screws.

### 6.4 Change of Direction for Rising Signal (discrete units).

6.4.1 Move actuator as in Section 6.2.1.

6.4.2 Remove positioner cover and undo the three M4 screws retaining the red retransmit plate, release the two wires on the terminal block connected to the DIN plug (if fitted), as shown in figure 7. Loosen the central coupling screw sufficiently to pull the coupling complete with the retransmit assembly off the actuator connection.

6.4.3 Release the potentiometer strap from the slot in the lower coupling, as shown in Figure 8, remove the internal indicator from the coupling and withdraw the coupling from the retransmit plate.

6.4.4 Pull the two halves of the coupling apart sufficiently to allow the cam to be withdrawn from its location peg. Flip the cam over and push it back into the slot between the two coupling halves and locate it back on the peg.

6.4.5 Refit the coupling to the retransmit plate and slide the internal indicator over the top of the coupling and refit the potentiometer strap into one of the two marked slots of the lower coupling (marked 'A' and 'C' for anticlockwise and clockwise movement respectively).



6.4.6 If when the coupling was removed, the collet was left behind on the actuator connection, remove the collet from the connection and push it into the lower half of the coupling ensuring that it locates in the semicircular 'pip' and tighten the clamping screw by two turns. Place the coupling and retransmit plate back on the actuator connection so that the cam follower is approximately half way up the rise of the cam whilst holding back the two retransmit wires and pull back the spring lever with the other hand and tighten the coupling clamping screw. Re-tighten the retransmit plate retaining screws and refit the retransmit wires to the terminal block.

6.4.7 The internal changeover block is not effective with a discrete positioner. The changeover of the air flow path is achieved by swapping over the external connections. It may also be preferred to turn the positioner through 180 degrees to simplify the external pipe runs.

6.4.8 The adjustment of zero and range is completed as in section 6.3.

### **6.5 Change of Angle Retransmit Direction Without Changing Positioner Direction**

If a non-standard rise in retransmit signal is required without a change in positioner direction, then this can be achieved by the following procedure.

6.5.1 Swap the top and bottom wires on the angle retransmit circuit which connect to the potentiometer.

6.5.2 Repeat the zero and range set-up procedure described in section 6.3.

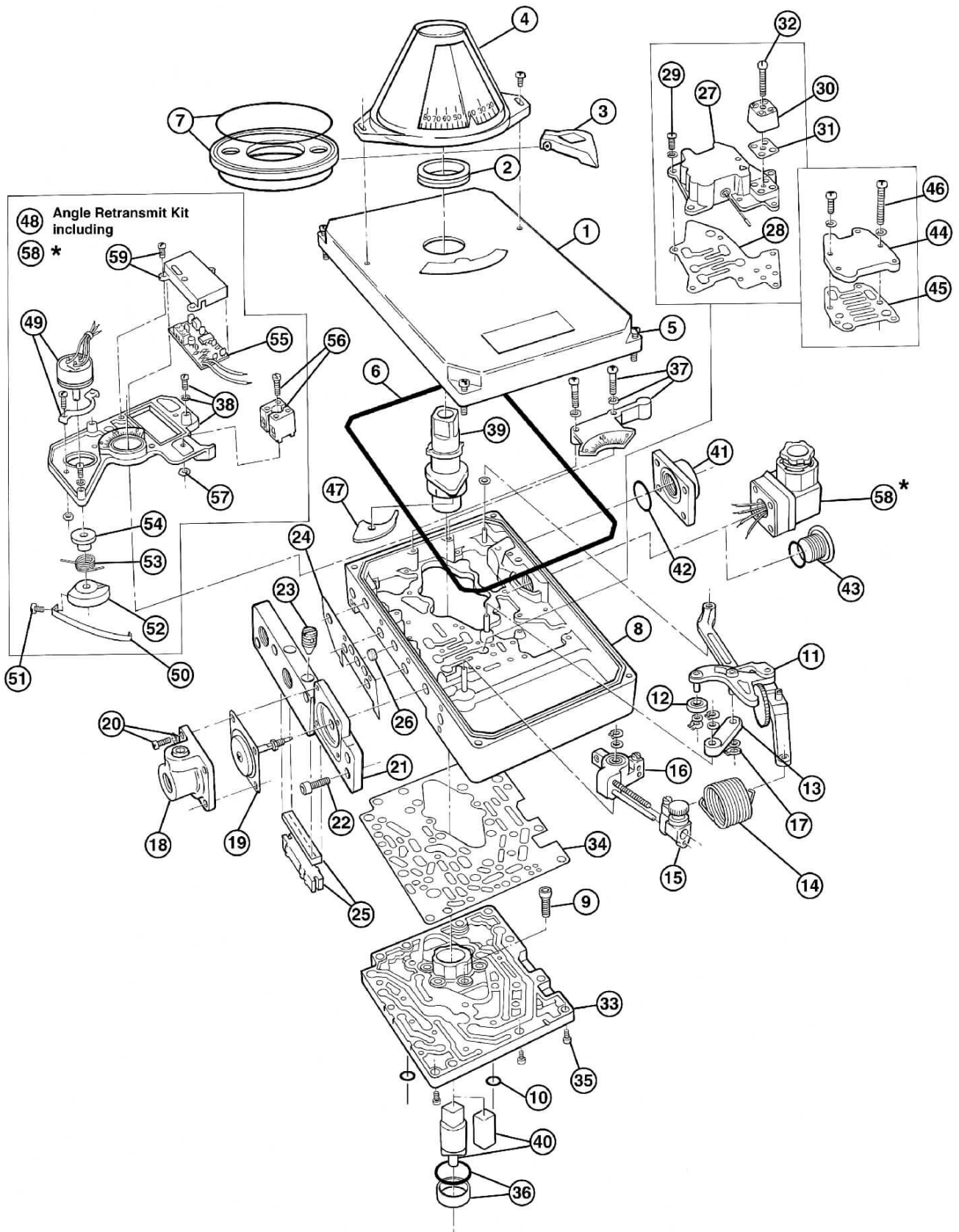



# Title: Installation & Maintenance – AP Pneumatic Positioner

ITEM NO.	DESCRIPTION	SPARES PART NUMBER				
		AP			MP	HP
		050	070	090	10 / 12 / 14	16/18/20/30
1	Cover Assembly - standard*	SP1200	SP1200	SP1200	SP1200	SP1200
	Cover Assembly – for switch box*	SP1201	SP1201	SP1201	SP1201	SP1201
2	Cover Seal & Grease - NBR	SP1202	SP1202	SP1202	SP1202	SP1202
	Cover Seal & Grease - Viton	SPV1202	SPV1202	SPV1202	SPV1202	SPV1202
3	Indicator Assembly	SP703	SP703	SP703	SP703	SP703
4	Monitor Kit ACW	SP978	SP978	SP978	SP978	SP978
	Monitor Kit CW	SP979	SP979	SP979	SP979	SP979
5	Cover screws	SP1203	SP1203	SP1203	SP1203	SP1203
6	'O' Ring (Lid) - NBR	SP1204	SP1204	SP1204	SP1204	SP1204
	'O' Ring (Lid) - Viton	SPV1204	SPV1204	SPV1204	SPV1204	SPV1204
7	Switch Box Spacer Plate & 'O' Rings	SP1205	SP1205	SP1205	SP1205	SP1205
8	Positioner Body*	SP1206	SP1207	SP1207	SP1207	SP1207
9	Screws (Pos/Act. Interface)*	SP732	SP733	SP733	SP733	-
10	'O' Rings (Pos/Act. Interface)	SP734	SP735	SP735	SP735	-
11	Cam/Spring Lever Assembly	SP1208	SP1208	SP1208	SP1208	SP1208
12	Cam Follower	SP1209	SP1209	SP1209	SP1209	SP1209
13	Short Link	SP1210	SP1210	SP1210	SP1210	SP1210
14	Feedback Spring	SP716	SP716	SP716	SP716	SP716
15	Range Adjuster Assembly	SP1211	SP1211	SP1211	SP1211	SP1211
16	Force Balance Lever Assembly	SP1212	SP1212	SP1212	SP1212	SP1212
17	Washer & Circlip	SP1213	SP1213	SP1213	SP1213	SP1213
18	Diaphragm Cover	SP720	SP720	SP720	SP720	SP720
19	Diaphragm Assembly - Polyurathane	SP1214	SP1214	SP1214	SP1214	SP1214
	Diaphragm Assembly - Viton	SPV1214	SPV1214	SPV1214	SPV1214	SPV1214
20	Screws & Washers (Diaphragm Cover)	SP721	SP721	SP721	SP721	SP721
21	Port Plate*	SP1215	SP1216	SP1216	SP1216	SP1217
22	Screws (Port Plate)	SP1218	SP1218	SP1218	SP1218	SP1219
23	Exhaust Regulators	SP1220	SP1220	SP1220	SP1220	SP1221
24	Port Plate Gasket	SP1222	SP1222	SP1222	SP1222	SP1223
25	Silencer & Silencer Clamp	SP1224	SP1224	SP1224	SP1224	SP1221
26	Inlet Filter	SP1225	SP1225	SP1225	SP1225	SP1226
27	Valve Block & Bobbin	SP1227	SP1228	SP1228	SP1229	SP1230
28	Valve Block Gasket - NBR	SP1240	SP1240	SP1240	SP1240	SP1240
	Valve Block Gasket - Viton	SPV1240	SPV1240	SPV1240	SPV1240	SPV1240
29	Screws & Washers (Valve Block)	SP1241	SP1241	SP1241	SP1241	SP1241
30	Changeover Block	SP1242	SP1242	SP1242	SP1242	SP1242
31	Changeover Gasket - NBR	SP1243	SP1243	SP1243	SP1243	SP1243
	Changeover Gasket - Viton	SPV1243	SPV1243	SPV1243	SPV1243	SPV1243
32	Screw & Washer (Changeover Block)	SP1244	SP1244	SP1244	SP1244	SP1244
33	Channel Plate - Standard*	SP1245	SP1246	SP1246	SP1246	SP1247
	Channel Plate - Discrete*	SP1247	SP1247	SP1247	SP1247	SP1247
34	Channel Plate Gasket	SP1248	SP1248	SP1248	SP1248	SP1248
35	Screws (Channel Plate)	SP1249	SP1249	SP1249	SP1249	SP1249
36	Bearing Bush & 'O' Ring (Discrete)	SP1250	SP1250	SP1250	SP1250	SP1250
37	Angle Scale & Screws	SP1251	SP1251	SP1251	SP1251	SP1251
38	Retransmit Plate, Bush and Screws (Discrete)	SP1252	SP1252	SP1252	SP1252	SP1252



# Title: Installation & Maintenance – AP Pneumatic Positioner

ITEM NO.	DESCRIPTION	SPARES PART NUMBER				
		AP			MP	HP
		050	070	090	10 / 12 / 14	16/18/20/30
39	Coupling	SP1253	SP1254	SP1254	SP1254	SP1253
	Discrete Coupling	SP1253	SP1253	SP1253	SP1253	SP1253
40	Discrete Drive Adaptor - Kinetrol	SP1255	SP1255	SP1255	SP1255	SP1255
	Discrete Drive Adaptor - Namur	SP1256	SP1256	SP1256	SP1256	SP1256
41	3/8 External Port Adaptor*	-	-	-	-	SP1257
42	'O' Ring (Port Adaptor)	-	-	-	-	SP1258
43	Blanking Plug*	SP1259	SP1259	SP1259	SP1259	SP1259
44	Valve Block Cap	-	-	-	-	SP1260
45	Valve Block Cap Gasket	-	-	-	-	SP1261
46	Valve Block Cap Screws & Washers	-	-	-	-	SP1262
47	Cam (See catalogue)	-	-	-	-	-
48	Angle Retransmit Kit (See catalogue)	-	-	-	-	-
49	Potentiometer	SP1263	SP1263	SP1263	SP1263	SP1263
50	Potentiometer Drive Strap	SP1264	SP1264	SP1264	SP1264	SP1264
51	Screw (Strap)	SP1265	SP1265	SP1265	SP1265	SP1265
52	Quadrant Wheel	SP1266	SP1266	SP1266	SP1266	SP1266
53	Torsion Spring	SP1267	SP1267	SP1267	SP1267	SP1267
54	Bush (Torsion Spring)	SP1268	SP1268	SP1268	SP1268	SP1268
55	Circuit	SP1269	SP1269	SP1269	SP1269	SP1269
56	Terminal Block	SP1270	SP1270	SP1270	SP1270	SP1270
57	Nuts (Angle Retransmit Plate)	SP1271	SP1271	SP1271	SP1271	SP1271
58	Din Plug*	SP1272	SP1272	SP1272	SP1272	SP1272
-	Recommended Spares Kit (NBR)	SP1280	SP1280	SP1280	SP1280	SP1280
-	Recommended Spares Kit (Viton)	SPV1280	SPV1280	SPV1280	SPV1280	SPV1280