

Key Features

- **FAST, SMOOTH AND ACCURATE RESPONSE**
From stepless cam drive and proportional spool valve.
- **UNIVERSAL APPLICATION**
Mount on any quarter - turn or linear actuator, single or double acting, in any orientation. Adjustable span may be set anywhere within the 100° range.
- **HIGH FLOW / GAIN VERSIONS**
93 nl/min (3.3 scfm), 283 nl/min (10 scfm) and 764 nl/min (27 scfm) models are available.
- **INTEGRAL OPTIONS – EASILY RETROFITTED MODULES**
 - two wire 4–20mA angle retransmit inside enclosure
 - mechanical or inductive position indication switches (for general and hazardous areas) in IP65 box
 - general and hazardous area 4–20mA I/P converter modules (intrinsically safe and NEMA 7 explosion proof options available)
 - high visibility Clear Cone angle monitor on positioner and switch box versions
 - DIN plug for external retransmit connection.
 - High Temperature seals for 100°C ambient applications.
- **SIMPLE, TIME SAVING FIELD SETUP**
Easy calibration and quick reversal of rotational sense without special tools or additional parts. Fast change of response characteristic cams.
- **COMPACT AND ROBUST METAL HOUSING**
Weatherproof sealed and epoxy painted for harsh industrial environments.
- **ATEX CATEGORY 1 APPROVAL**
Upto Category 1 approval on most versions, Category 2 approval on some others (Actuators also approved).
- **PROVEN FORCE BALANCE SYSTEM**
Employing unique straight - line mechanism—minimising wear, backlash and friction. Positioning is unaffected by supply pressure fluctuations.
- **VISUAL POSITION INDICATION**
External pointer / scale or high visibility Clear Cone angle monitor plus internal angle scale for field setup.
- **INSTALLATION FLEXIBILITY**
Mount on any actuator using VDI / VDE 3845 NAMUR drive, or Kinetrol male square, with mounting brackets, or direct mount (with integral porting) to Kinetrol actuators.
- **VIBRATION AND SHOCK RESISTANT**
Low mass spool and robust mechanism provide 4G / 100Hz industrial vibration tolerance in any attitude.
- **ADAPTATIONS AND ACCESSORIES**
Consult Kinetrol for:
 - split range or customized cams
 - special failure modes eg fail-freeze
 - filters, regulators and gauges
 - mounting kits for rotary / linear drives.

AP Pneumatic Positioner

DIMENSIONS

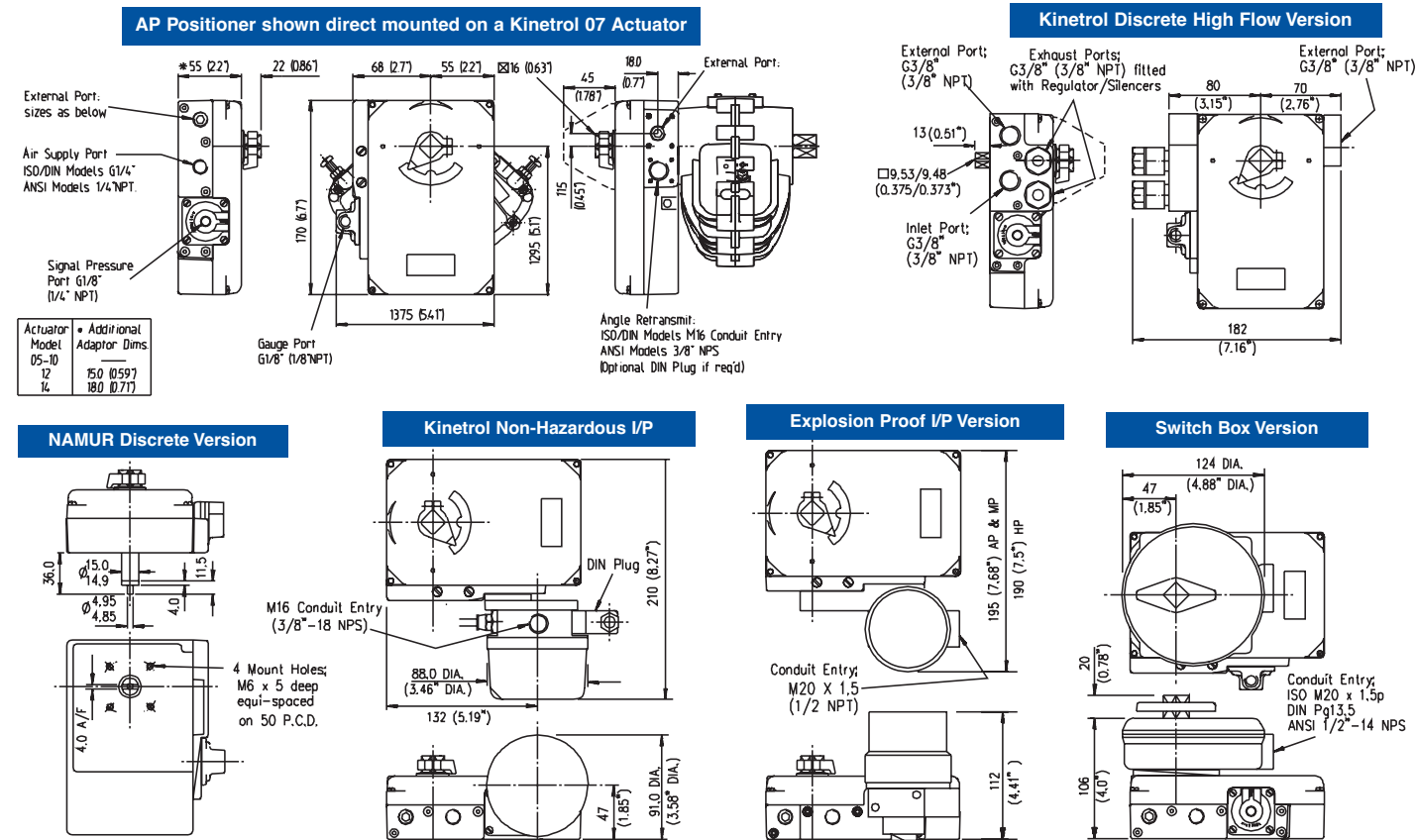

SPECIFICATION

Air Supply	instrument quality (dry, clean, oil free) 3.5 to 7.0 bar, 50psi to 100psi standard consult Kinetrol for low pressure application	Materials	case and cover - zinc alloy spool and liner - stainless steel diaphragm - polyester reinforced-polyurethane or High Temperature feedback spring - steel
Signal	3 – 15psi (0.2 – 1.0 bar) standard consult Kinetrol for split range, 6-30psi etc	Finish	epoxy stove enamel
Control Response	0 – 90° linear output standard consult Kinetrol for other characteristic cam options	Enclosure rating	IP54
Sensitivity	better than 0.7% of span	Output torque	same as double acting or spring return actuator when controlling fast movement of inertia loads consult Kinetrol
Hysteresis	better than 0.7% of span	Vibration tolerance	4G, 100Hz
Deviation from linearity	less than 1.0% of span	I/P converter options	Non - hazardous Supply pressure 4 – 5.5 bar (60 – 80 psi)
Flowrates	AP: 3.3 scfm (93 nl/min) @5.5 bar MP: 10.0 scfm (283 nl/min) @5.5 bar HP: 27.0 scfm (764 nl/min) @5.5 bar		ATEX EEx d IIC T6 EEx ia IIC T4/T5/T6
Operating temperature range	-20° to 80°C standard -20° to 100°C High Temperature		FM Class I Division 1 explosion proof Groups B,C,D intrinsically safe Groups A,B,C,D,E,F,G
Weight	2.8 kg / 6.2 lb		CSA Class I Division 1 explosion proof Groups B,C,G intrinsically safe Groups A,B,C,D
Hazardous area use:	Without A/R switches ATEX Cat 1 mechanical approval 1G g 90°C With A/R switches ATEX Cat 1 1G EExia IIC T4		



Certificate No. FM 22163

The policy of KINETROL is one of continuous improvement. We reserve the right to alter the product as described and illustrated without notice.

KINETROL

Kinetrol Ltd, Trading Estate, Farnham, Surrey GU9 9NU, England
Telephone: 01252 733838 Fax: 01252 713042
e-mail: sales@kinetrol.com

KF 391 07/04

KINETROL



AP Pneumatic Positioner

AP Pneumatic Positioner

The AP pneumatic positioner combines the smoothness and accuracy of Kinetrol's proven mechanical positioner technology (using a proportional spool valve driven by a simple, accurate and robust force balance mechanism) with new advances in convenience and simplicity of use, derived from the unique innovative design both of the internal mechanism and of the overall package.

The result is a positioner with unparalleled performance and real industrial robustness, sweet and easy to calibrate and characterize, and adaptable to the whole range of applications with its unbeatable list of options – high flow valves, direct mount or industry standard discrete mount housings, 4-20mA angle retransmit, limit switches, Clear Cone position monitor and I/P converters (either simple or with various explosion proof options).

CARRIER PLATE ASSEMBLIES – integrated assemblies carrying the feedback shaft and cam plus angle retransmit drive and pot (when specified). Easily removed for conversion or maintenance.

FEEDBACK POT DRIVE – zero backlash, proven trouble free for life.

OPTIONAL ANGLE RETRANSMIT CIRCUIT – externally powered (8–30v DC) linear 4-20mA feedback, rangable down to 30° for full 4-20mA span. Easily accessible zero and span adjustment.

RETRANSMIT POT – high quality conductive plastic servo-type with ball bearings. Proven long life and high precision.

ACTUATOR INTERFACE – options include NAMUR standard (shown), Kinetrol male square or Kinetrol direct mount female square. Quick external conversion allows bracket mounting to any rotary or linear actuator.

INTERCHANGEABLE PORT PLATES – easily convertible for different flowrate options.

INTERNAL ANGLE SCALE – with adjustable indicator for easy field calibration.

EXHAUST SNUBBER SCREWS – allow travel speed reduction down to 1/3 x full speed, independently in each direction, by screwing in to restrict exhaust air flow.

GAUGE PORT – as standard.

SPAN ADJUSTMENT – quick and easy thumbwheel setting with slotted locking screw.

ENCLOSURE – robust die-cast metal with tough corrosion-resistant epoxy coating and O-ring sealing. Layout gives easy access to all adjustments on removal of lid.

LID – shown with optional Clear Cone sealed angle monitor. Epoxy coated die-cast metal held on by four captive screws gives quick access to the interior.

UNIT IDENTIFICATION – each positioner carries a unique serial number and is CE marked.

STRAIGHT-LINE MECHANISM – unique geometry allows cw/ccw change over by simple cam inversion.

3-TERMINAL DIN PLUG – retrofitable option available for 4-20mA angle retransmit. Allows fully external connection with rapid connect/disconnect capability.

ZERO ADJUSTMENT – quick and easy thumbwheel setting with slotted locking screw.

AIRFLOW CHANGEOVER BLOCK – allows selection of direction in which positioner moves (for direct mount models).

SPOOL VALVE – highly reliable, all metal, 5 port proportional valve controls the air flow. Three versions, with different flowrates, are easily interchangeable.

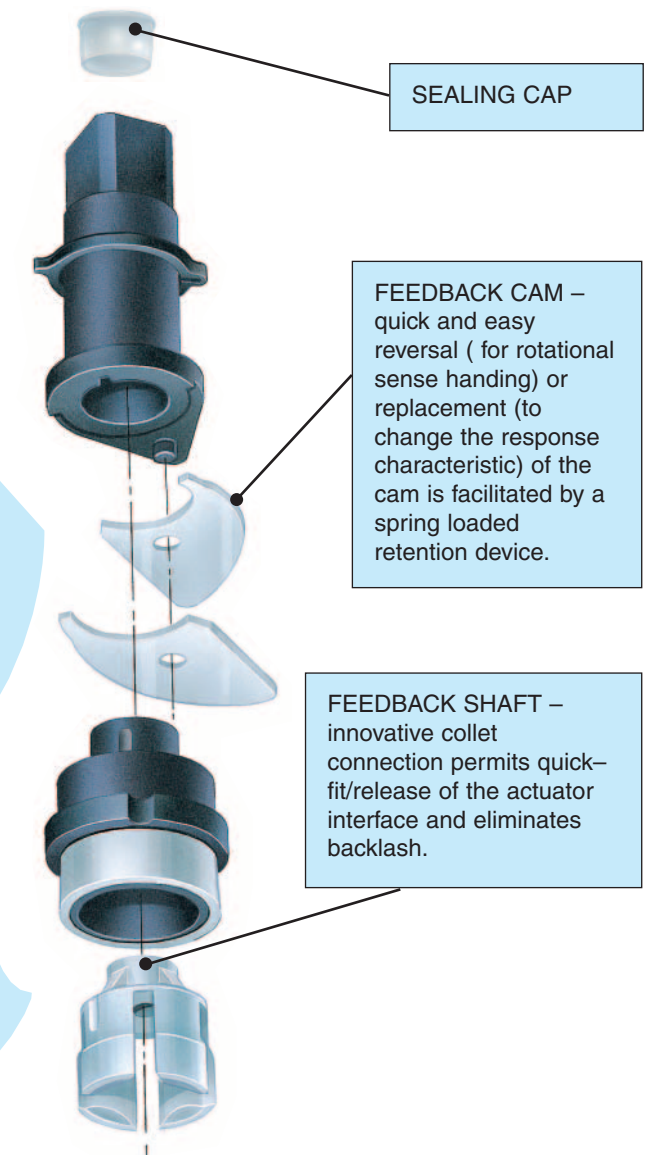
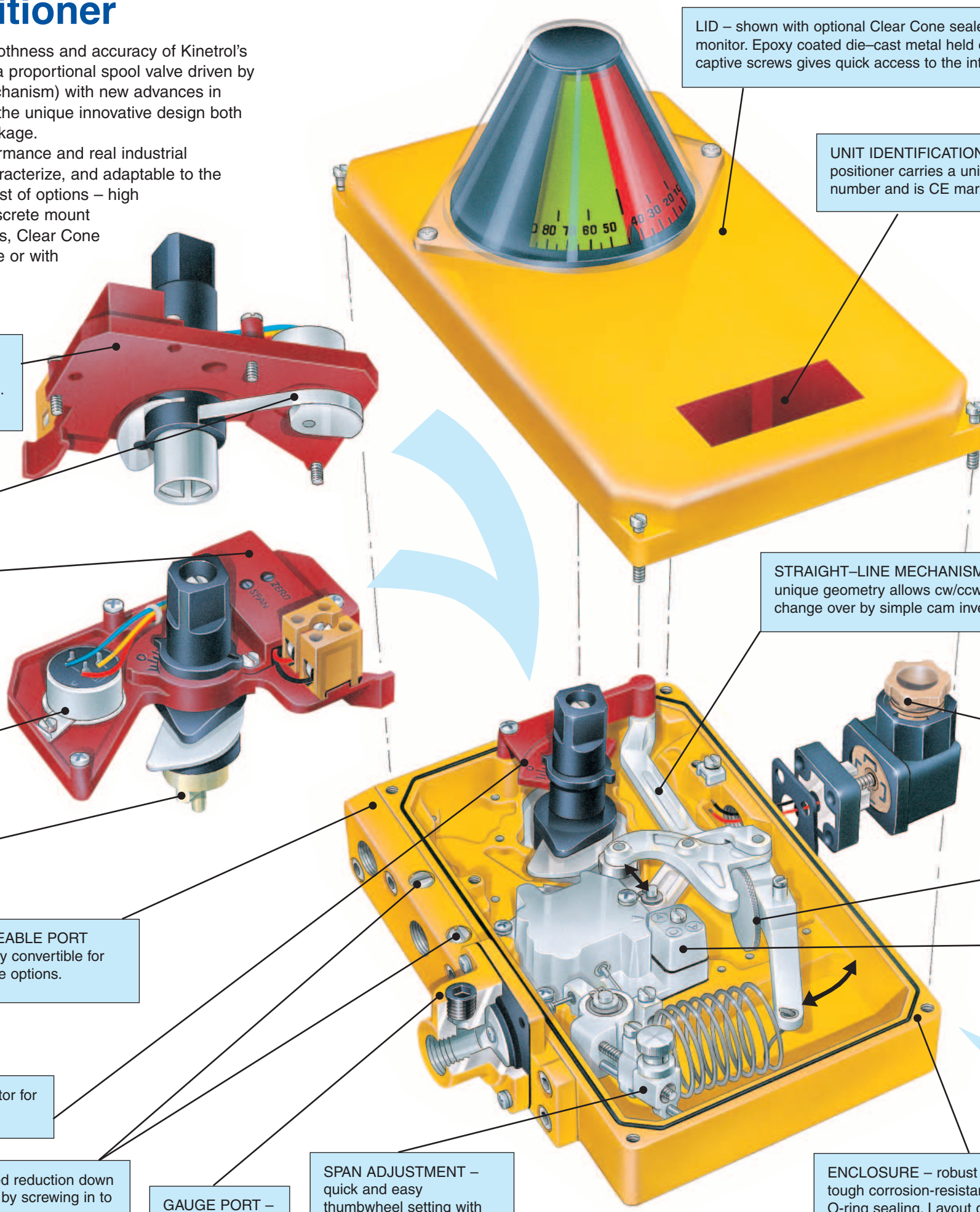

SEALING CAP

FEEDBACK CAM – quick and easy reversal (for rotational sense handing) or replacement (to change the response characteristic) of the cam is facilitated by a spring loaded retention device.

FEEDBACK SHAFT – innovative collet connection permits quick-fit/release of the actuator interface and eliminates backlash.

OPERATING PRINCIPLES

The AP positioner is designed to drive a rotary or linear actuator to a position set by a 3-15 psi (0.2 - 1.0 bar) signal and hold it there until the signal changes.

SCHEMATIC FUNCTIONAL DIAGRAM

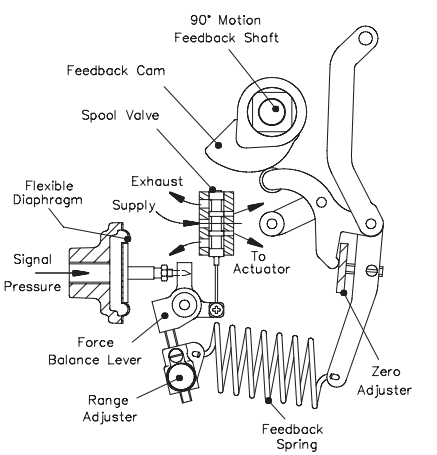

When a signal pressure is applied to the diaphragm it moves the force balance lever clockwise against the tension of the feedback spring. This moves the spool valve, supplying air pressure to one side of the actuator while exhausting trapped air from the other side. The feedback shaft follows the movement of the actuator and turns the cam counter clockwise, pushing the cam follower and increasing the tension on the feedback spring until it balances the force on the diaphragm and moves the spool valve to its central 'hold' position.

The relationship between the input signal and desired position (the 'characteristic') is determined by the cam profile. A linear 3-15 psi (0.2 - 1.0 bar) signal / 0-90° output movement cam is standard. Split range, fast opening, equal percentage or customized characteristic cams are available.

ORDERING CODES

Actuator Assembly & Porting 0= No actuator 4= Act + Pos ccw + IP 5= Act + Pos ccw 6= Act + Pos cw 7= Act + Pos cw + IP	Angle Retransmit / ATEX Approved 0= None 1= AR ccw & Conduit* 2= AR cw Conduit* 3= AR ccw & DIN plug* 4= AR cw & DIN plug* 5= AR ccw IS 6= AR cw IS 7= NO AR - ATEX Approved	Seals, Diaphragms & Porting 0 = Internal Ports Nbr V = Internal Ports (high temp) E = External Piping Nbr F = External Piping (high temp)
Actuator Model (See Actuator codes) 0= No LS 1= 2 x SR 2= SR ccw 3= SR cw 4= Pos only ccw + IP 5= Pos only ccw 6= Pos only cw 7= Pos only cw + IP	Limit Switch 0= No LS 1= 2 x IS prox 2= 2 x Pneumatic* 3= 2 x EEX e II T6 4= 2 x V3 mech LS 5= 20 - 240 V ac prox.* 6= 5 - 30 V dc prox.* 7= 4 x V3 mech LS*	IP 0= No IP 1= Non hazardous + DIN plug* 2= EEXd (Cat 2) 3= FMCSACLII 4= Non hazardous + Conduit* 5=EEXia (Cat 2)
Valve Sizes A=Standard M=Medium Flow H=High Flow	* Not available with ATEX approval	Clear Cone Monitor* (Optional)

*A Valve is supplied with all sizes up to and inc' 09
 *M Valve is supplied with 10-14
 *H Valve is supplied with sizes 16-30
 * Unless specifically requested otherwise Recommended spring unit for model 14 actuator is 4900 type. This should be coded 12□49AP or 13□49AP instead of the usual 12□AP or 13□AP. The same applies to other specially coded spring assemblies.