

NOTES:

1. ALL FLAT WELDS & HORIZ. FILLETS PER WPS 7-032, 3-039, 7-048 OR 7-054. ALL "POSITION WELDS" & WELDS OF CONN'S (UNDER 2" NOM. PIPE SIZE) TO SHELL PER W.P.S. 3-015, UNLESS OTHERWISE INDICATED.
2. PAINT PER INSTRUCTIONS ON SALES ORDER.
3. AFTER ALL TESTING AND CLEANING IS COMPLETE, CHARGE PER M-405.
4. CLEAN SHELL PER ENG. STD. M-90.
- 5.
6. COMPLETE ALL WELDING PRIOR TO HYDROSTATIC TEST.
7. CERTIFICATION AND CLASSIFICATION PER M-139. YORK CLASS B VESSEL. SHELL CHAMBER TEST PER M-382, PARA. 5.8 & 5.4.
- 8.
- 9.
10. DATA NAMEPLATE STAMPING AS FOLLOWS:

W		(by Q.C.)		(National Board Serial Number)		CERTIFIED BY		(Name of Manufacturer)	

11. FOR REFRIGERANT THREADED JOINTS UP TO 1/2" USE SEALANT PART NO. 013-03989-000, RED, LOCTITE 554. FOR REFRIGERANT THREADED JOINTS 1/2" TO 3" USE SEALANT PART NO. 013-03056-000, RED, LOCTITE 227 PER APPLICATION PROCEDURES IN M-365.

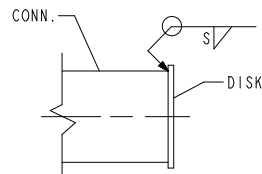
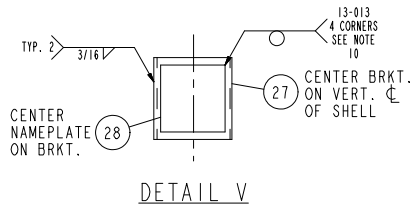

CONN. SIZE	S
8	5/8
12	11/16
16	11/16

DETAIL W

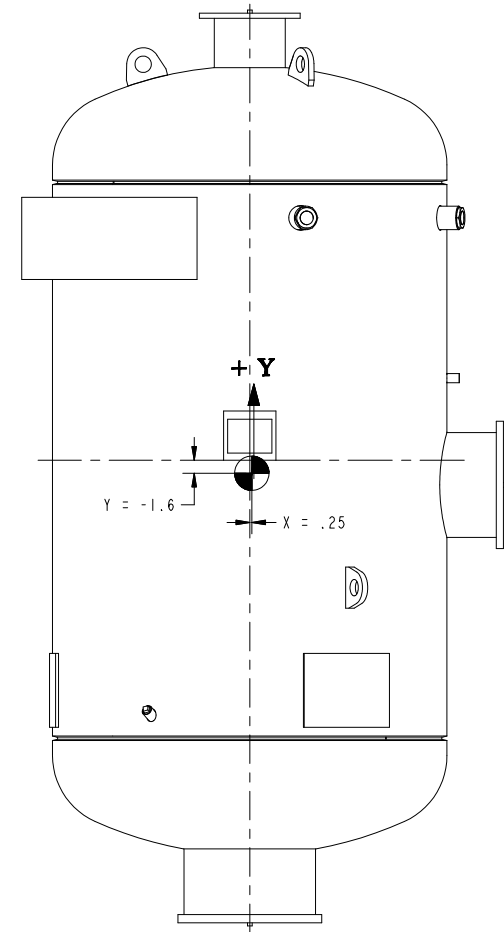
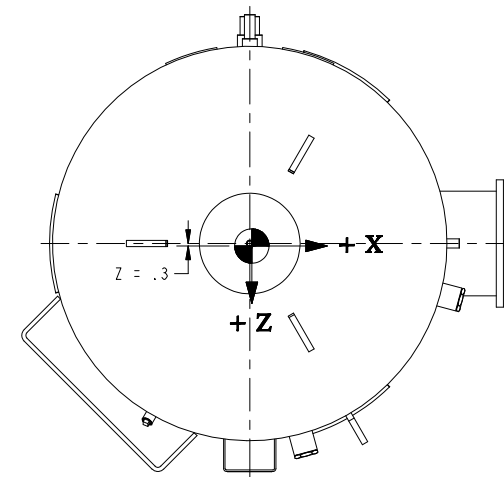

= CENTER OF GRAVITY

CENTER OF GRAVITY

THIS VESSEL CONFORMS TO THE REQUIREMENTS OF THE ASME PRESSURE VESSEL CODE SECTION VIII, DIVISION I, LATEST EDITION AND ADDENDA.

YC10-059

S.O. 0J060251-03 THRU 18



YORK INTERNATIONAL CORPORATION
YORK, PA 17405

REV.	DATE	EC. NO.	DR.	CHK.	ENG.
B	28-MAR-2011	CS11-0193	MJV	MJV	
SHT 2: ADDED LEADER TO WELD SYMBOL AT LOC. C-8; 15/16 DIM. WAS 1-15/16 IN CHART AT DETAIL Z; REVISED ITEM 7 AND ADDED ITEM 37 AT LOC. B-7.					
CONTINUED					

"ALL PROPRIETARY RIGHTS IN THE SUBJECT MATTER HEREOF ARE RESERVED AND NO PERMISSION IS GRANTED TO REPRODUCE THIS PRINT IN WHOLE OR IN ANY PART, OR DISCLOSE ANY OF THE INFORMATION UPON IT TO OTHERS WITHOUT WRITTEN RELEASE BY YORK INTERNATIONAL CORPORATION"

DIMENSIONS ARE IN INCHES
DO NOT SCALE
TOLERANCES PER ENG. STD. M-282

DRAWN M. J. VANBUREN 28-SEP-2010
MODELER M. J. VANBUREN 27-SEP-2010
CHKD M. J. VANBUREN 30-SEP-2010
ENG

DWG-ECON FLASH
48 OD X 8' Y CL B
300 DWP TITAN

MATERIAL
ENG. STD.
PART NO.
CUT SIZE

SCALE: .043	WEIGHT: 3400	ORIG. NO.: 377-227780 REV. -	SHEET 1 OF 2	RELEASED
-------------	--------------	------------------------------	--------------	----------