

SECTION B-B

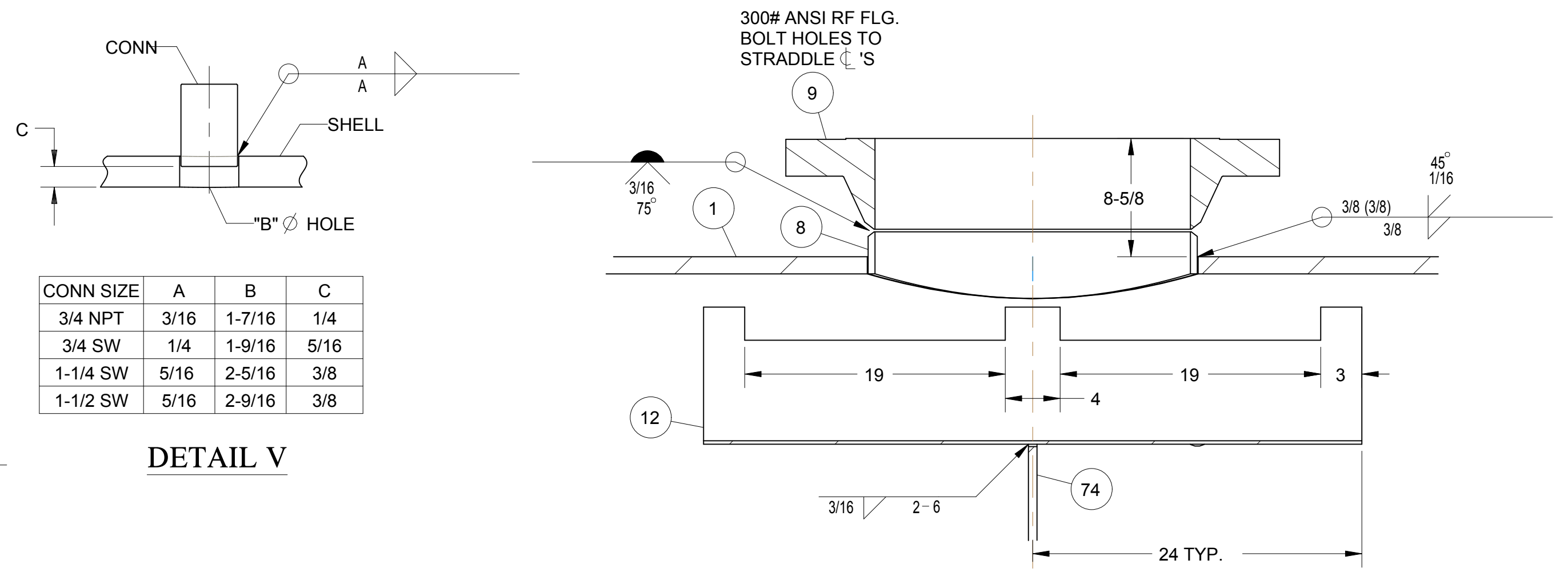

DETAIL V

SECTION C-C

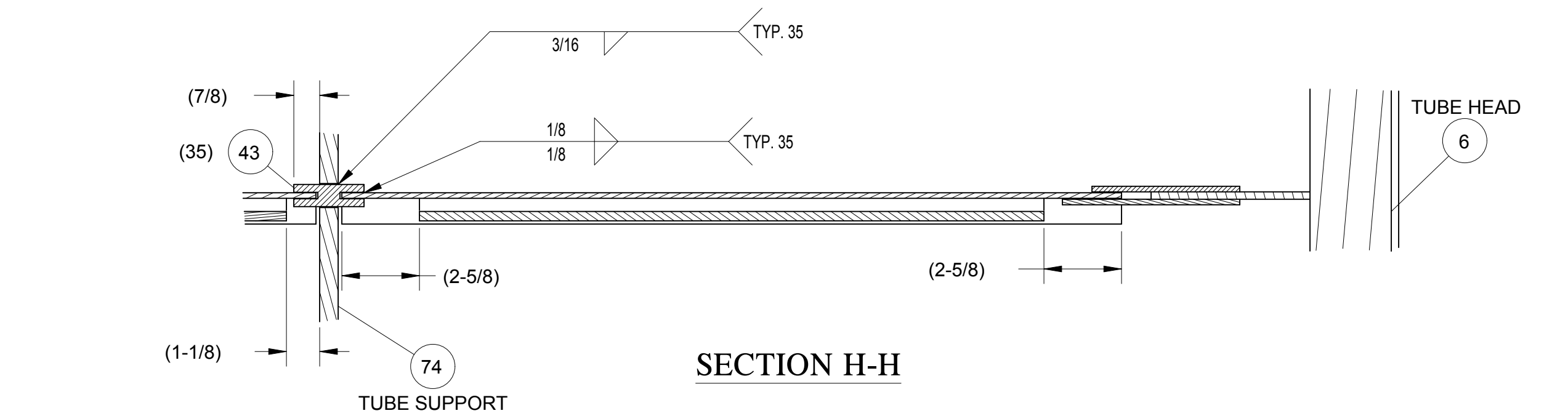

SECTION H-H

TUBE SUPPORT

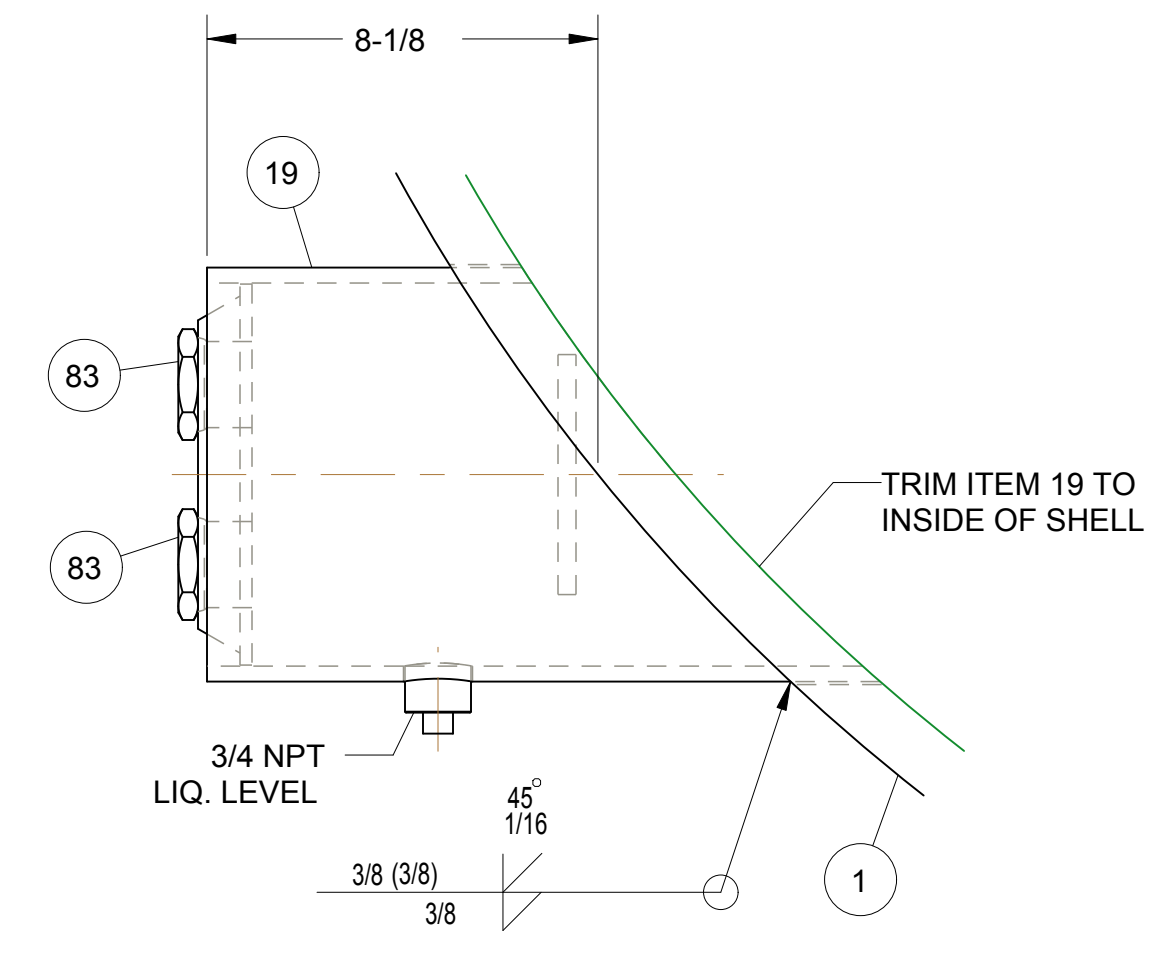

DETAIL M

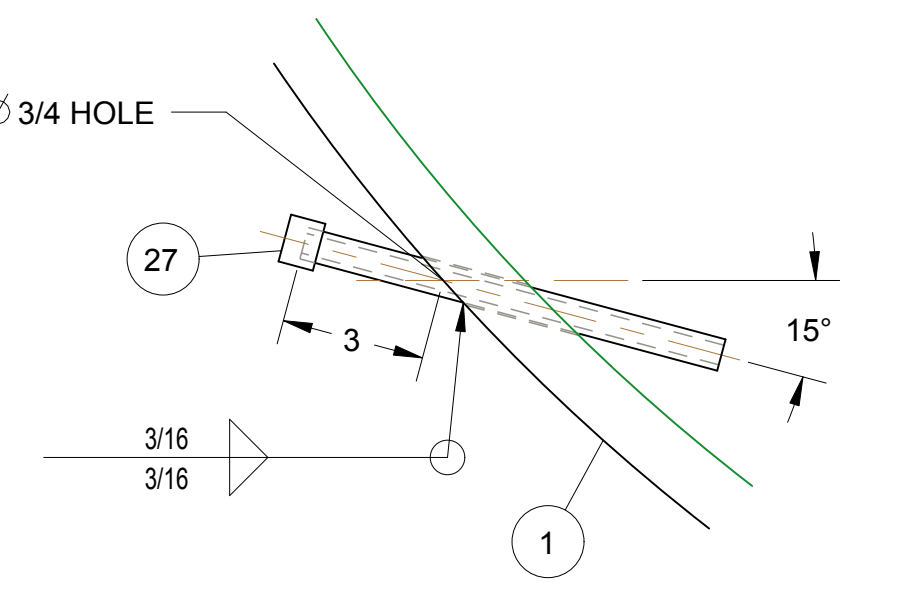

DETAIL N

REV.	DATE	EC. NO.	DR.	CHK.	ENG.
G	30-JUNE-2011	CS11-0208	KLS	KLS	

REFILM: SHEET 3, REVISED DETAIL V

REVISION	CONTINUED

ALL PROPRIETARY RIGHTS IN THE SUBJECT MATTER HEREOF ARE RESERVED AND NO PERMISSION IS GRANTED TO REPRODUCE THIS PRINT IN WHOLE OR IN ANY PART, OR DISCLOSE ANY OF THE INFORMATION UPON IT TO OTHERS WITHOUT WRITTEN RELEASE BY YORK INTERNATIONAL CORPORATION

		YORK INTERNATIONAL CORPORATION YORK, PA 17405	
DIMENSIONS ARE IN INCHES DO NOT SCALE TOLERANCES PER ENG. STD. M-282	DWG-CONDENSER 82 ID X 18 LG Y CL B 2 PASS, 4948 TUBES 300/150 DWP TITAN	MATERIAL ENG. STD. PART NO. CUT SIZE	DRAWING NUMBER 077-31991-000
DRAWN K.L. SEIPLE 30-SEP-2010 MODELER K.L. SEIPLE 30-SEP-2010 CHKD K.L. SEIPLE 07-OCT-2010 ENG	CAGE NUMBER D 66935	DRAWING NUMBER 077-31991-000	REVISION G 1 RELEASED
SCALE: .012	WEIGHT:	ORIG. NO.: 077-14994D REV. -	SHEET 3 OF 4