

# PresSure Products Company, Inc.

4540 WEST WASHINGTON STREET  
CHARLESTON, WV 25313

## ASSEMBLY INSTRUCTIONS FOR B WELD

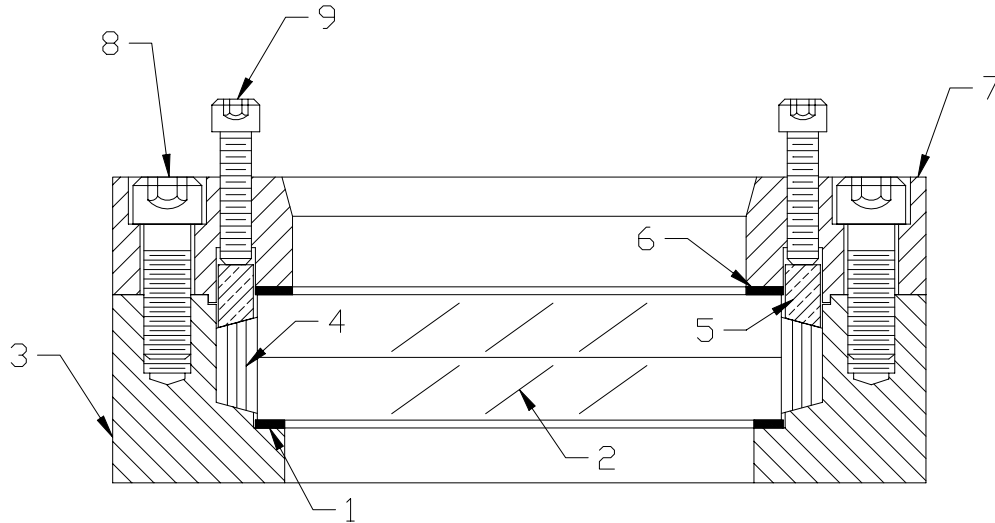

This unit was assembled for shipment and the cap screws (8) were purposely not tightened. Before installation, the sight glass unit should be disassembled by removing the cap screws (8), cap (7), compression ring (5), lens (2), packing (4) and cushion gaskets (1 & 6). Replace only the cap (7) and tighten the cap screws (8). The cap (7) will help prevent the body (3) from warping during the welding process. Use an appropriate welding procedure to minimize distortion of the body. After the body has been welded and cooled, follow the instructions below to reassemble the unit.

### INSTALLING PARTS:

- (1) The interior of the unit body (3) must be clean.
- (2) Place the bottom cushion gasket (1) into the unit body (3).
- (3) Carefully place lens (2) on top bottom cushion gasket (1).
- (4) Insert lens packing (4) between the lens (2) and the interior wall of the unit body (3).
- (5) Place the compression ring (5) beveled-side down on top of the packing (4).
- (6) Place the top cushion gasket (6) on top of the lens and inside of the compression ring.
- (7) Place the retainer cap (7) into position and install the cap screws (8). Due to non-compression of the packing (4), the cap (7) may ride on the compression ring (5). If this should occur, tighten the cap screws (8) until the cap (7) and body (3) make contact.
- (8) Insert the compression adjustment screws (9) and tighten incrementally across diameters 8-10 ft-lb.
- (9) Occasionally, when pressure is applied, the packing (4) will loosen. Should leakage occur, follow the tightening procedure, outlined in step (8), until leakage has stopped.

IF THERE ARE ANY QUESTIONS CALL 1-800-624-9043

