

FOR TURBOMASTER UNITS (MULTI-STAGE M COMPRESSORS) AND SINGLE STAGE DRIVE LINE UNITS (LTD AND LK COMPRESSORS)

* HIGH AND LOW SPEED COUPLING ALIGNMENT

*NOTE: HIGH SPEED COUPLING AS REFERED TO IN THIS INSTRUCTION IS THE COMPRESSOR DRIVE COUPLING. ON SINGLE STAGE COMPRESSORS THE HIGH SPEED COUPLING IS ACTUALLY LOW SPEED IN OPERATION.

TABLE OF CONTENTS

HIGH SPEED COUPLING INSTALLATION AND ALIGNMENT	3
INSTALLATION	3
ALIGNMENT	3
INITIAL DOWELING	6
FINAL ALIGNMENT CHECK	6
ESTIMATED COLD MISALIGNMENT CALCULATION SHEET	8
LOW SPEED COUPLING ALIGNMENT	9
CHECKING COLD ALIGNMENT	9
CHECKING HOT ALIGNMENT	10

In a permanent log for future reference, record alignment readings both cold and hot as illustrated. Also record spacer thickness and thrust clearance of the compressor.

HIGH SPEED COUPLING

Readings taken between speed increaser and compressor

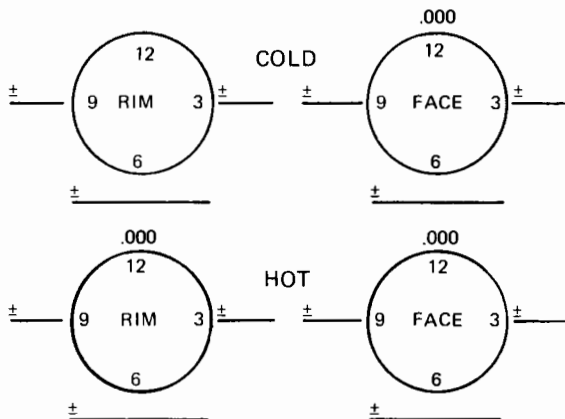

Bull Gear Float =
Pinion Gear Float =

Total Gear Float =

Total Spacer Thickness
Compressor Thrust Clearance

LOW SPEED COUPLING

Readings taken between Motor and Gear

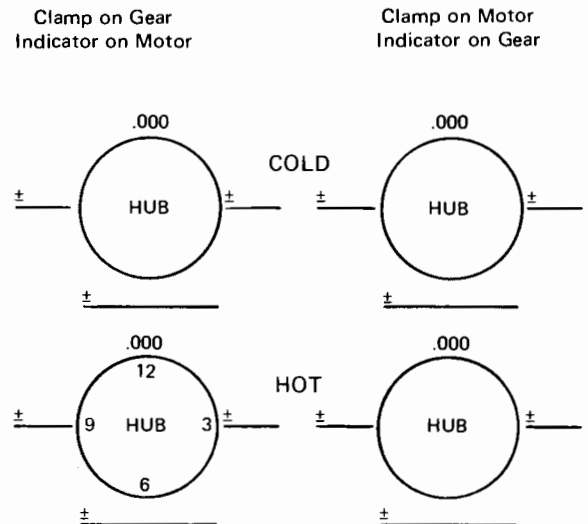

Clamp on Gear
Indicator on Motor

Clamp on Motor
Indicator on Gear

REF. NO.	DESCRIPTION
1	COUPLING COMPLETE
2	SPACERS
3	DRIVE SHAFT NUT
4	SOCKET HEAD CAP SCREWS
5	COMPRESSOR CLAMP RING
6	COMPRESSOR HUB DISC
7	DRIVING HUB DISC
8	DRIVING CLAMP RING
9	WASHERS
10	NUTS

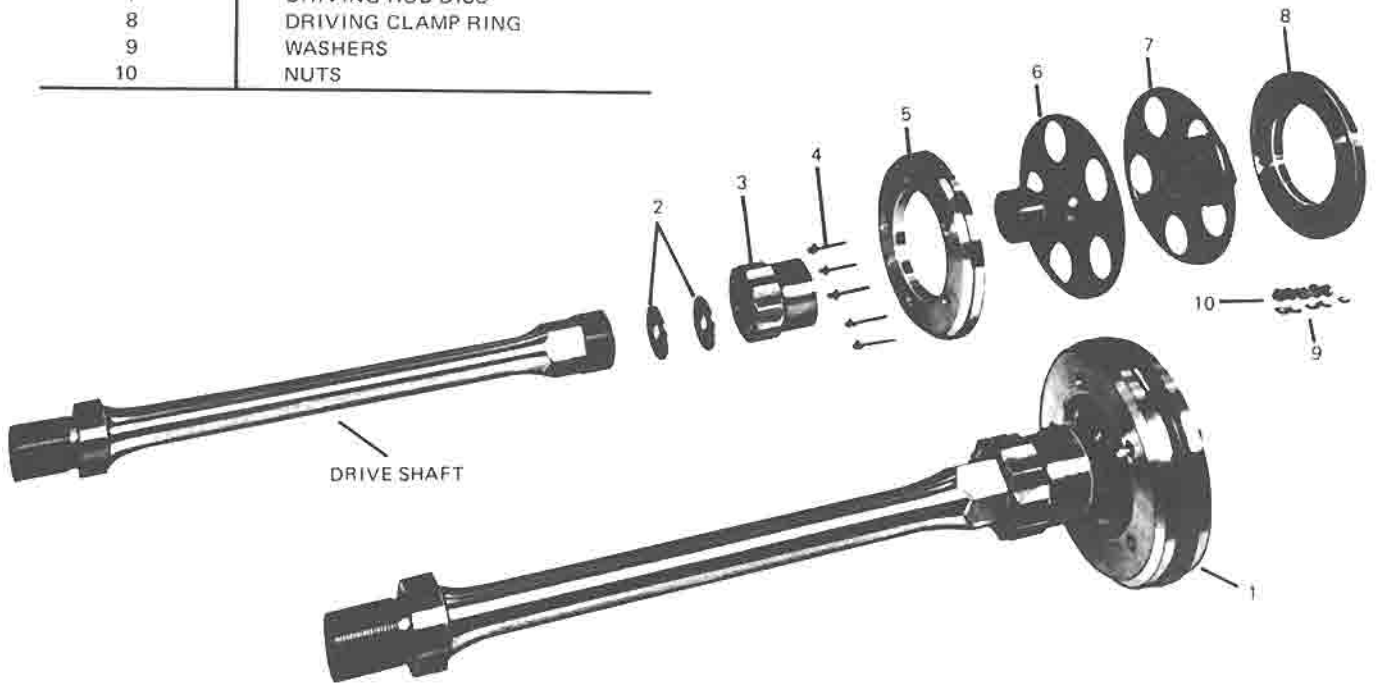

REF. NO.	DESCRIPTION	SIZE						
		1"	1-1/4"	1-1/2"	1-7/8"	2-1/2"	3"	3-3/4"
1	Coupling Complete	364-30009	364-24654	364-22205	364-24655	364-24656	364-24657	364-17734
2	Spacers	064-27519-.001 thru .006 (1 set)	064-16817-.001 thru .006 (1 set)	064-16765-.001 thru .006 (1 set)	064-14395-.001 thru .006 (1 set)	064-13866-.001 thru .006 (1 set)	064-13835-.001 thru .006 (1 set)	064-17732-.001 thru .006 (1 set)
3	Drive Shaft Nut	*	*	*	*	*	*	*
4	Screws Socket Head	021-13949 (3)	021-13189 (3)	021-12880 (3)	021-13191 (5)	021-11662 (5)	021-13192 (5)	021-13193 (5)
5	Clamp Ring (Compressor)	*	*	*	*	*	*	*
6	Hub Disc (Compressor)	*	*	*	*	*	*	*
7	Hub Disc (Driving)	*	*	*	*	*	*	*
8	Clamp Ring (Driving)	*	*	*	*	*	*	*
9	Washers	064-30008 (6)	064-14393 (6)	064-13865 (6)	064-13865 (10)	064-13834 (10)	064-17730-.003 (10)	064-24648 (10)
10	Nuts	021-13950 (3)	021-12109 (3)	021-11675 (3)	021-11675 (5)	021-10260 (5)	021-10635 (5)	021-13188 (5)

* Not Furnished Separately

FIG. 1 — YORK-FLEX COUPLING

HIGH SPEED COUPLING INSTALLATION AND ALIGNMENT

HIGH SPEED COUPLING INSTALLATION

A YORK-FLEX High Speed Coupling is furnished with each Turbomaster Compressor.

Before installing the YORK-FLEX Coupling, the compressor and driver must be in place on their respective bases with suction and discharge connections properly installed with a minimum of strain.

Dirt and burrs should be removed from base, shims, and component feet. Shims are required for all driver components and base plate mounted compressors. No shims are required for compressors mounted on steel drive line bases.

To install the YORK-FLEX High Speed Couplings, refer to Fig. 1 and proceed as follows:

1. Screw the driving hub disc on the output shaft of the driver without its clamp ring. Both hub discs and shafts are equipped with double left hand threads. Snug the threads but **DO NOT DRAW THEM TIGHT**. (About 20% of torque)
2. Screw the drive shaft nut and compressor hub disc on the compressor drive shaft without the clamp ring and spacers.
3. For axial rim separation adjust the equipment so the outer rims of the hub discs are separated by the amount shown in TABLE 1. Since the compressor should be permanently located with respect to its suction and discharge lines, the adjustment should be made in the position of the driver. Before making a measurement, the compressor shaft must be against its thrust bearing in its normal running position.

Pull a Series M compressor shaft toward the coupling, and push a Series LK or LTD compressor shaft away from the coupling.

IMPORTANT

It is very important that the rim separation in TABLE 1 be maintained throughout the alignment process so that later the standard spacers furnished with the coupling can be used in the final assembly.

When selecting the spacers the various components must be in their normal running positions. If a SPEED INCREASER is used, its output shaft should be in the center of its end play (include both gear and pinion end play). If the driver is a MOTOR, its shaft should be at the running magnetic center as determined by operating the motor uncoupled. When a compressor is TURBINE driven, the turbine shaft should be against its thrust

bearing in the normal running position. Turbine thrust is usually toward the exhaust end.

To facilitate the final alignment procedure, the two hubs should first be brought into approximate alignment by means of a straightedge across the rims of the hub discs at the top, bottom, and both sides. Before taking any readings the drive components must rest solidly on their shims and base. These components will probably not have a flat plane base so it will rock on two diagonally opposite feet. If there is any rocking motion, the open point must be shimmed. Check for flat mounting plane as follows:

- (a) With all four tie-down bolts tightened, set No. 1 indicator at the 12 o'clock position and observe the reading. Loosen one foot and observe indicator. If indicator moves more than .002", the mounting plane is not flat.
- (b) Add additional shims of equal thickness under the loosened foot and the foot diagonally opposite until tightening and loosening no longer affects the indicator.
- (c) If loosening one foot does not move the indicator, retighten it and loosen an adjacent foot. If this produces more than .002" indicator travel, this foot and its diagonal opposite foot require shimming. Adjust shims this way until loosening any two adjacent feet (one at a time) produces less than .002" indicator travel.

HIGH SPEED COUPLING ALIGNMENT

The complete alignment procedure consists of four basic steps which, if carefully followed, will eliminate unnecessary shifting of equipment and will assure accurate alignment. These steps are as follows:

1. Vertical angular alignment.
2. Vertical parallel alignment.
3. Horizontal angular alignment.
4. Horizontal parallel alignment.

By rotating both discs, the runout is eliminated from the readings, therefore, rotate both discs equally when taking a reading.

1. Check Coupling Alignment (Mount indicator on driver shaft as per Fig. 2, page 4.)
 - (a) Check vertical angular alignment by setting the dial to 0.000" when in the top position on the compressor rear hub face. Rotate both discs 180 degrees. Half of this reading is the amount of correction necessary. A minus means the driver must be raised on the end away from the compressor.

TABLE 1— YORK-FLEX COUPLING DATA

THREAD SIZE (IN.)	RIM SEPARATION WITHOUT SPACERS (IN.)	MAXIMUM MISALIGNMENT DURING NORMAL OPERATION (T.I.R.)			BOLT SIZE (IN.)	BOLT TORQUE
		LATERAL (RIM)	ANGULAR (FACE)	AXIAL MISALIGNMENT ± INCHES		
1	3/16 (±1/64)	.008	.006	.012	No. 10	76 in. lbs
1-1/4	3/16 (±1/64)	.008	.006	.012	1/4	136 in. lbs
1-1/2	1/4 (±1/32)	.010	.007	.014	5/16	23 foot lbs
1-7/8	1/4 (±1/32)	.012	.008	.016	5/16	23 foot lbs
2-1/2	1/4 (±1/32)	.014	.009	.020	3/8	41 foot lbs
3	1/4 (±1/32)	.016	.010	.025	1/2	100 foot lbs
3-3/4	1/4 (±1/32)	.020	.012	.031	5/8	200 foot lbs

T.I.R. - Total Indicator Reading is double the Actual Misalignment

Potentially, Step 1 is the most time-consuming. The usual method of correcting vertical angular misalignment is tilting the driver into the correct position using shims. Selection of correct shim thickness is made by trial and error. Much time can be saved - and accuracy gained - by using a simple proportion.

The angle of change needed at the base is the same as the angle of misalignment. Because of this angular relationship, the shim thickness is proportional to the misalignment. Shim thickness required is as many times greater than the misalignment as the base length is greater than the diameter subscribed by the indicator stem. For example, suppose the diameter of the circle subscribed by the indicator stem is 6" on indicator

#2 Figure 2, that the amount of correction required is .006", and the base length of the driver is 24". Therefore, the required shim thickness is $\frac{24}{6} \times .006" = .024"$.

- (b) Check vertical parallel alignment with the indicator button on the OD of the compressor or hub disc. The amount of correction necessary is half of the indicator reading obtained from top to bottom. A minus reading means the driver must be raised.
- (c) During horizontal angular alignment, the indicator button again rests against the compressor rear hub face. The reading being taken from side to side.

DIAL INDICATOR IN #1 POSITION. FOR VERTICAL PARALLEL ALIGNMENT READ AT 12 & 6 O'CLOCK POSITIONS, FOR HORIZONTAL PARALLEL ALIGNMENT READ AT 9 & 3 O'CLOCK POSITIONS.

DIAL INDICATOR IN #2 POSITION. FOR VERTICAL ANGULAR ALIGNMENT READ AT 12 & 6 O'CLOCK POSITIONS. FOR HORIZONTAL ANGULAR ALIGNMENT READ AT 9 & 3 O'CLOCK POSITIONS.

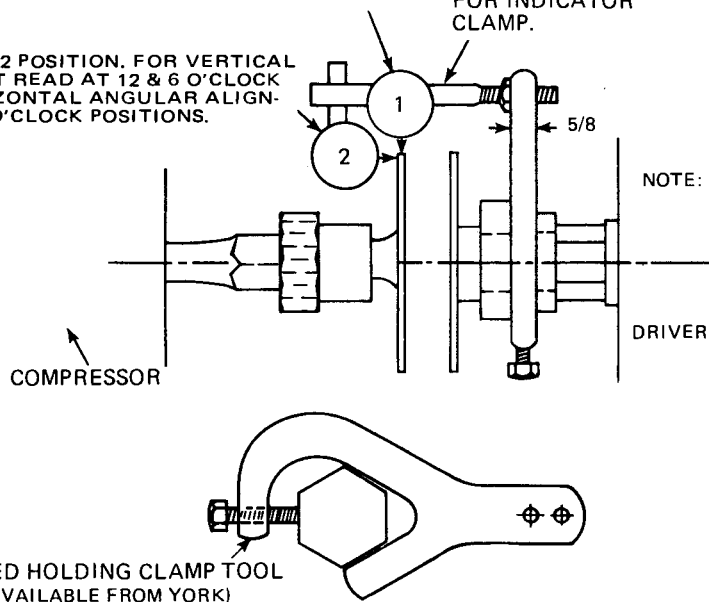

NOTE: MAGNETIC DIAL INDICATOR HOLDERS ARE NOT SUITABLE FOR SHAFT COUPLING ALIGNMENT.

USE STARRETT #196A DIAL INDICATOR OR SIMILAR SIZE AND TYPE. USE A MIRROR TO FACILITATE EASY READING.

PLACE INDICATOR STEM IN THE CENTER OF ALLOWABLE SPACE FOR INDICATING, NOT ON THE END. TO ASSURE ACCURATE READINGS WHICH CAN BE REPEATED THE STEM OF THE INDICATOR MUST POINT TO THE CENTER OF THE SHAFT WHEN LOOKING AT THE END OF THE INDICATOR AND BE PERPENDICULAR TO THE SHAFT.

FIG. 2 — DIAL INDICATOR ARRANGEMENT AND SUGGESTED CLAMPING FOR COLD ALIGNMENT

**TABLE 2 — COMPRESSOR SHAFT FALL (INCHES)
SERIES M COMPRESSOR**

COMPR SIZE	INLET SUCTION GAS TEMPERATURE - F				
	30	0	-30	-60	-90
25"	.004	.007	.010	.013	.016
26"	.004	.007	.010	.013	.016
38"	.005	.009	.013	.017	.021
55"	.007	.013	.019	.025	.031

- (d) For horizontal parallel alignment, the indicator reading is taken from side to side on the OD of the compressor hub disc.

NOTE: (Record alignment readings on the High Speed Coupling Log located on the Front Cover.)

The final readings can be taken with one indicator set up on the face and one on the rim. (See Fig. 2) The tolerances for misalignment are listed in TABLE 1, page 4.

When a Series M Compressor is connected to a driver, the position of the compressor shaft with respect to the driving shaft will change from idle to operating conditions. The amount of fall may be estimated from TABLE 2.

When a Series LK compressor is aligned to a driver the following pre-conditions are required:

1. With flexible compressor suction and (or) discharge connections — approximately 135°F compressor sump oil temperature and approximately 70 psig system pressure. The compressor drive shaft end play (low speed thrust clearance) must be determined prior to introducing pressure into the system.
2. With solid compressor suction and discharge connections — approximately 135°F compressor sump oil temperature.

The position of a Series LTD or LK compressor shaft will not change appreciably from idle to operating conditions (approximately .001" per foot of shaft center line height above the mounting base).

When a SPEED INCREASER is connected to the compressor, the high speed gear shaft will rise slightly as it warms up during operation. This rise may be estimated as .004" per foot of shaft center line height above the speed increaser feet.

There is also a horizontal thermal expansion estimated as .004" per foot of the distance between the center line of the pinion shaft and the center line of the bull gear shaft. Therefore, the pinion shaft should be offset horizontally one-half this amount. A further correction should be made to compensate for the running position of the shafts in the bearings of the speed increaser under operating conditions as discussed under "Low Speed Coupling Alignment", page 9.

When a MOTOR is connected to the compressor, its shaft rise may be estimated as .001" per foot of shaft center line height above the motor feet.

When a TURBINE is connected to the compressor, a greater rise in shaft elevation must be expected. Because of the great variation in operating temperatures and methods of mounting encountered, there is no general rule for estimating this rise. The best procedure is to operate the turbine uncoupled and measure the shaft displacement at operating temperature. This should include both angular and parallel movements, horizontal and vertical.

To obtain correct angular and parallel alignment at running conditions, within the tolerances given in TABLE 1, page 4, requires that the equipment be misaligned at idle conditions by the amounts determined above for the compressor and its driver.

The calculation sheet is for your convenience in arriving at the estimated vertical and horizontal misalignment requirements.

To obtain correct axial alignment of the high speed coupling it is necessary to measure the end play of the compressor shaft and the driver shaft. In checking a speed increaser be sure to push and pull the high speed shaft hard enough to move the low speed shaft against its thrust surfaces. The axial position of a motor shaft in its running magnetic center must also be determined by operating the motor uncoupled. (See TABLE 1.)

ASSEMBLING THE HIGH SPEED COUPLING

After the coupling has been properly aligned and the axial play measured refer to Fig. 1, page 2, and proceed as follows:

Assembling the Coupling

1. Screw the drive shaft nut completely onto the drive shaft and remove both hub discs. After coating the threads with YORK Turbo Compressor Drive Thread Compound, reinstall the driving hub disc with the clamp ring in place. This compound will prevent thread seizing and is available from YORK in 1/4 pint cans, YORK Part No. 464-14934. Assemble the driven hub disc and clamp ring to the driving hub disc and clamp ring with the nuts, bolts and washers, positioning the hub discs so the bolts are centered in the large clearance holes. Thoroughly clean and lubricate the bolt threads with oil and tighten the nuts gradually and evenly with a Torque wrench to the torque specified in TABLE 1, page 4. DO NOT LUBRICATE THE CLAMPING SURFACES OF THE DISCS AND CLAMP RINGS.

Axial Alignment

1. Position the DRIVING SHAFT into the driver as far as it will go.

Position the COMPRESSOR SHAFT into the compressor as far as it will go.

NOTE: Series LK Compressors are sometimes aligned under pressure and it is not possible to push the drive shaft in and have it remain in that position under these conditions.

Measure the distance between the ends of the compressor hub disc and the drive shaft.

2. From these measurements:

(a) For a Series M Compressor

- (1) For a SPEED INCREASER drive subtract all of the compressor end play and also half of the measured speed increaser end play. The remainder is the nominal amount of spacer thickness to insert between the compressor hub disc and the drive shaft end. Standard spacers are furnished in various thicknesses and two should be inserted having a total thickness of less than the nominal amount by .000" to .005".
- (2) For a MOTOR drive, subtract all of the compressor end play and also the distance from the motor position in Step 2, page 5, to the measured position of the motor shaft in its running magnetic center. The remainder is the nominal amount of spacer thickness to insert between the compressor hub disc and the drive shaft end. Standard spacers are furnished in various thicknesses and two should be inserted having a total thickness of less than the nominal amount by .000" to .005".
- (3) For a TURBINE drive, subtract all of the compressor end play and all of the turbine end play if the normal turbine thrust is toward the compressor. Do not subtract any turbine end play if its thrust is away from the compressor. The remainder is the nominal amount of spacer thickness to insert between the compressor hub disc and the drive shaft end. Standard spacers are furnished in various thicknesses and two should be inserted having a total thickness of less than the nominal amount by .005" to .015" depending on the amount of turbine axial shaft growth anticipated. Allow for compressor axial growth to achieve proper running axial position.

(b) For Series LTD compressors -

- (1) For a SPEED INCREASER drive, subtract half of the measured speed increaser end play. The remainder is the nominal amount of spacer thickness to insert between the compressor hub disc and the drive shaft end. Standard spacers are furnished in various thicknesses and two should be inserted having a total thickness of less than the nominal amount by .000" to .005".
- (2) For a MOTOR drive, subtract the distance from the motor position in 2 above to the measured position of the motor shaft in its running magnetic center. The remainder is the nominal amount of spacer thickness to insert between the compressor hub disc and the drive shaft end. Standard spacers are furnished in various thicknesses and two should be inserted having a total thickness of less than the nominal amount by .000" to .005".

- (3) For a TURBINE drive, subtract the turbine end play if the normal turbine thrust is toward the compressor. Do not subtract any turbine end play if its thrust is away from the compressor. The remainder is the nominal amount of spacer thickness to insert between the compressor hub disc and the drive shaft end. Standard spacers are furnished in various thicknesses and two should be inserted having a total thickness of less than the nominal amount by .005" to .015" depending on the amount of turbine axial shaft growth anticipated.

(c) For Series LKA Compressors -

- (1) For a Speed Increaser drive, add all of the Compressor end play if the system is under pressure and subtract half of the measured speed increaser end play. The remainder is the nominal amount of spacer thickness to insert between the compressor hub disc and the drive shaft end. Standard spacers are furnished in various thicknesses and two should be inserted having a total thickness of less than the nominal amount by .000" to .005".
- (2) For a Motor drive, add all of the compressor end play if the system is under pressure and subtract the distance from the motor position in 2 above to the measured position of the motor shaft in its running magnetic center. The remainder is the nominal amount of spacer thickness to insert between the compressor hub disc and the drive shaft end. Standard spacers are furnished in various thicknesses and two should be inserted having a total thickness of less than the nominal amount by .000" to .005".
- (3) For a Turbine drive, add all of the compressor end play if the system is under pressure and subtract all of the turbine end play if the normal turbine thrust is toward the compressor. Do not subtract any turbine end play if its thrust is away from the compressor. The remainder is the normal amount of spacer thickness to insert between the compressor hub disc and the drive shaft end. Standard spacers are furnished in various thicknesses and two should be inserted having a total thickness of less than the nominal amount by .005" to .015" depending on the amount of turbine axial shaft growth anticipated.

3. After the spacers have been determined and installed, screw the drive shaft nut into a central position over both threads.

INITIAL DOWELING

At this point the equipment should be shallow doweled. To minimize movement of the coupling halves with respect to one another, dowel the mounting feet at the coupling end of a Series M compressor. This permits the compressor to expand away from the coupling. The usual dowel pins furnished with the compressor are No. 2 Morse taper and require 9/16" drilled holes through the mounting feet, shims and sole plates. If possible, drill a small hole all the way thru to permit dirt and chips to fall thru bottom of dowel hole. Carefully ream these drilled holes with No. 2 Morse taper reamers, roughing and finishing, until the dowel pins fit well and drive tight with approximately 3/4" of the taper protruding.

Finish reaming by hand. Do not hit the reamer with a hammer and never turn the reamer in reverse. Use cutting oil on the reamer.

NOTE: Some catalogs may list "Morse Taper Reamers" as "Standard Taper Reamers" to differentiate from other tapers.

Dowel two diagonally opposite feet for a SPEED IN-CREASER unless the manufacturer has specified otherwise. Dowel the opposite mounting feet of a motor, or dowel turbine feet at the coupling end.

FINAL ALIGNMENT CHECK

During operation, the compressor usually becomes cold and the driver usually becomes hot. A gas compressor

suction temperature is hot during operation. As the system reaches normal operating temperatures, the alignment between the compressor and the driver changes. To assure that the alignment is correct in accordance with TABLE 1 during operation, a final alignment check should be made as follows:

1. After the system has been initially operated under load for a sufficient period of time (at least 6 hours) to permit the compressor and driver to reach normal operating temperatures, the system should be shut down, the coupling should be partially disassembled and a final alignment check made while both the compressor and driver are near running temperatures.

Have the special YORK-FLEX coupling wrenches, Fig. 3., handy before shutting down so the drive shaft nut can be loosened quickly while the equipment remains near operating temperatures. To remove the spacers screw the drive shaft nut onto the compressor hub disc sufficiently until they fall out. The indicators should be mounted as shown in Fig. 4.

2. Measure coupling alignment with both the compressor and driver as near their operating temperatures as possible. The maximum misalignment at normal operating conditions must not exceed the tolerances of TABLE 1, page 4. Axial alignment should be within $\pm .003''$ of true running position.
3. If the results are within the tolerances, reassemble the coupling and ream the dowel pin holes of the compressor and driver for full depth seating.

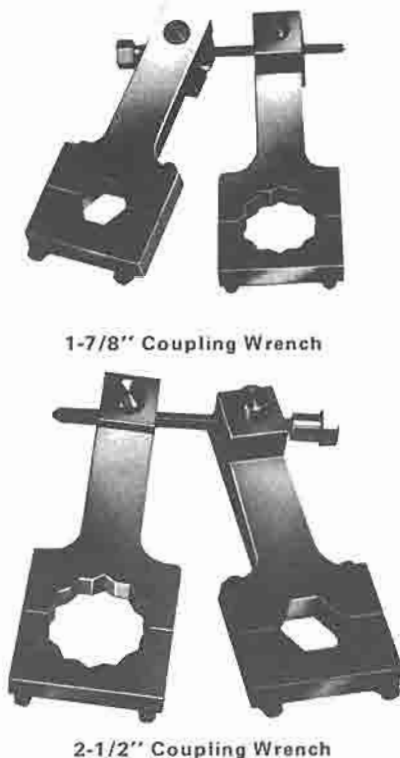

FIG. 3 — YORK FLEX-COUPLING WRENCHES

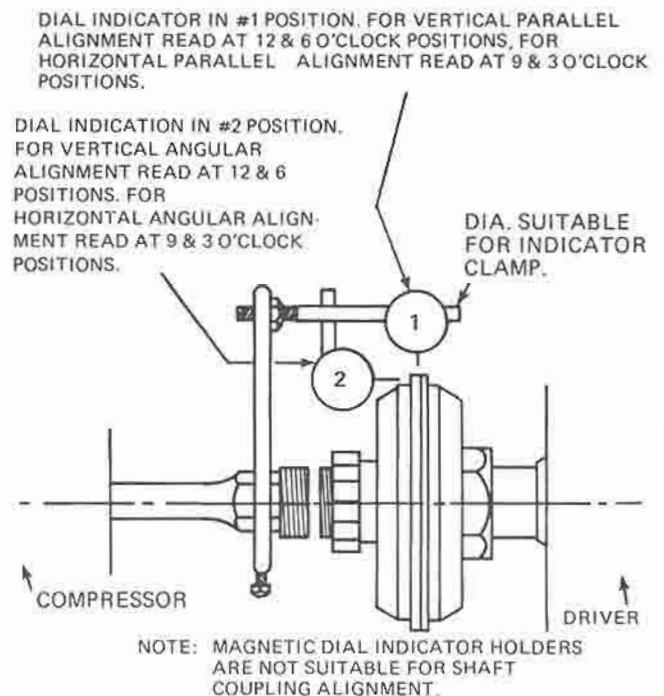

FIG. 4 — DIAL INDICATOR ARRANGEMENT AND SUGGESTED CLAMPING FOR HOT ALIGNMENT

4. If the results are not within the tolerances of TABLE 1, page 4, allow the equipment to return to ambient temperature and realign as indicated by the measurements.

5. Repeat steps 1 through 4 above until satisfactory operating alignment is achieved.
 6. Following this, check the low speed coupling alignment.

ESTIMATED TURBOMASTER COMPRESSOR COLD MISALIGNMENT CALCULATION SHEET

Speed Increaser center line to base = _____ inches (A)

Speed Increaser Thermal vertical expansion = $\frac{A}{12} \times .004'' =$ _____ inches (B)

Speed Increaser center line pinion to center line bull gear = _____ inches (C)

Speed Increaser Thermal horizontal expansion = $\frac{C}{12} \times .004'' =$ _____ inches (D)

Pinion Shaft diameter in bearings _____ inches Speed _____ RPM

Pinion bearing clearance from graph _____ inches (E)

Bull gear shaft diameter _____ inches Speed _____ RPM

Bull gear bearing clearance from graph _____ inches (F)

Motor center line to base = _____ inches (G)

Motor Thermal vertical expansion = $\frac{G}{12} \times .001 =$ _____ inches (H)

Turbine thermal vertical expansion _____ inches (I)

Compressor Thermal contraction or expansion (See Table 1) = _____ inches (J)

Vertical misalignment—center line compressor shaft above center line pinion shaft = $J + B =$ _____ inches (K)

Horizontal misalignment—centerline compressor shaft to center pinion shaft = $\frac{D}{2} + \frac{E}{2} =$ _____ inches (L)

Vertical misalignment—center line motor shaft above center line bull gear shaft = $B - H =$ _____ inches (M)

Horizontal misalignment—center line bull gear shaft to center line motor shaft = $\frac{D}{2} + \frac{F}{2} =$ _____ inches (N)

Vertical misalignment—center line compressor shaft above center line turbine shaft = $J + I =$ _____ inches (O)

NOTE: DETERMINE VERTICAL AND HORIZONTAL DISPLACEMENT BY OPERATING TURBINE UNCOUPLED.

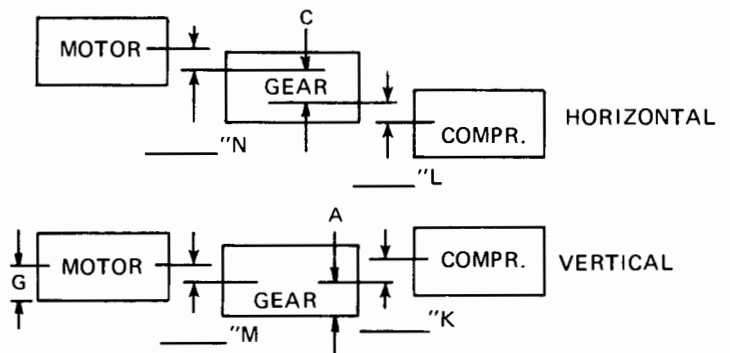
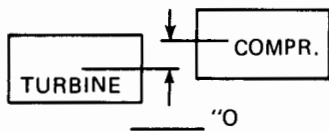

COLD MISALIGNMENT REQUIRED
 NOTE: A HOT FINAL ALIGNMENT MUST BE MADE WHILE COMPONENTS ARE NEAR OPERATING TEMPERATURE.

CONCENTRICITY OF ASSEMBLED COUPLING PARTS IS ESSENTIAL ON HIGH SPEED UNITS. CHECK BEFORE STARTUP. ALL PARTS SHOULD BE WITHIN .002 TIR.

LOW SPEED COUPLING ALIGNMENT

LOW SPEED COUPLING ALIGNMENT

To obtain correct axial alignment of the low speed coupling it is necessary to measure end play of the speed increaser and the motor shaft. In checking the speed increaser be sure to push and pull hard enough to move low speed shaft against its thrust surfaces. Check the end play of the motor. If the motor has ball bearings, the end play should be less than .005" and may be ignored. If motor has journal bearings, the end play will be greater than .005" and the shaft will be scribed to indicate its running position, called magnetic center. If the magnetic center is not scribed, it should be determined by operating the motor uncoupled.

The axial alignment should be such that with the speed increaser in the center of its end play and the motor shaft at magnetic center the space between the ends of the respective shafts must conform to the dimensions shown on the drawings. The purpose of axial spacing of speed increaser and motor is to prevent any excessive thrust on the motor bearings and allow the speed increaser to operate in the center of its axial float range without external restriction.

CHECKING COLD ALIGNMENT

During cold alignment the coupling is disassembled. Due to the close distance between the faces of the low speed coupling hubs it is difficult to obtain accurate readings between the faces of the two coupling hubs. To check angular alignment carefully measure with a straight edge and feeler gauge or a tapered wedge gap gauge. Record the distances between the inside faces of the two hubs at the 12, 3, 6 and 9 o'clock positions rotating both hubs equally so as to eliminate runout.

An alternate method if space permits is to set up the dial indicator as per Fig. 5.

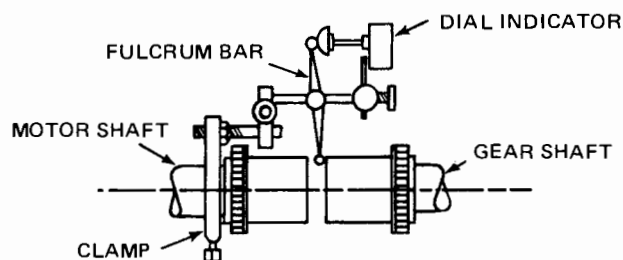
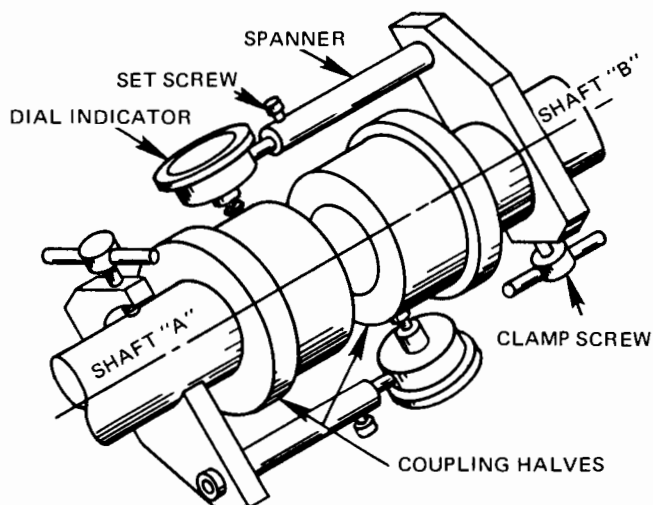

FIG. 5 — ALTERNATE METHOD -CHECKING COLD ALIGNMENT

Clamp the indicator to the motor hub or shaft with the small ball at the end of the indicator fulcrum bar resting against the face of the gear hub and the larger ball at the other end of the indicator fulcrum bar resting against the foot of the dial indicator. Take readings at the 12, 3, 6, and 9 o'clock positions rotating both hubs equally so as to eliminate runout.

The final check should always be made by means of the double dial indicator method also known as the reverse

reading method. Alignment is established by indicating the outside circumference of the speed increaser hub and the outside circumference of the motor hub. (See Fig. 6.)



Take indicator readings at the 12, 3, 6 and 9 o'clock positions on both the motor hub and the gear hub rotating both the motor shaft and the speed increaser shaft together equally so as to eliminate runout from the readings.

FIG. 6 — PREFERRED METHOD -CHECKING COLD ALIGNMENT

The motor shaft should be misaligned to the speed increaser shaft to recognize that the speed increaser shaft will move both vertically and horizontally as it warms up during operation. The vertical rise is estimated to be .004" per foot of shaft center line height above the speed increaser feet. The horizontal thermal expansion due to temperature rise may be estimated as .004" per foot of the distance between the center line of the pinion shaft and the center line of the bull gear shaft. Therefore the motor shaft should be offset horizontally one-half this amount.

A further correction can be made to compensate for the running position of the shafts in the bearings under operating conditions as indicated in Fig. 7.

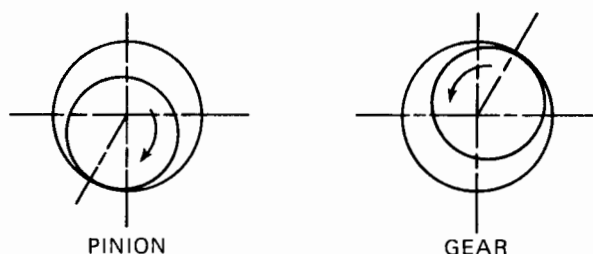
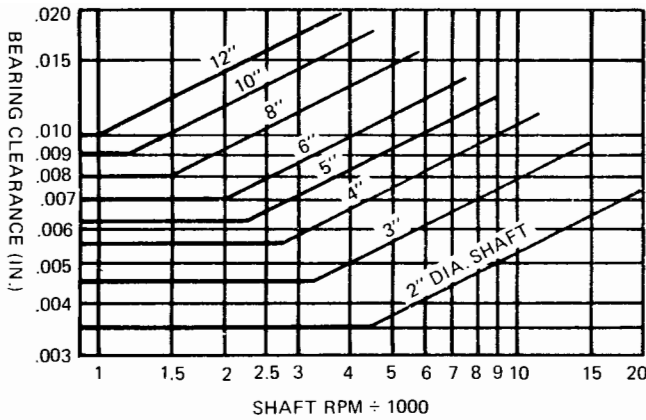

FIG. 7 — APPROXIMATE RUNNING POSITION OF SHAFT BEARING UNDER OPERATING CONDITIONS

The amount of bearing clearance can be obtained from the chart on bearing clearance. (Fig. 8)



Based on 150 SSU @ 100° F. oil with inlet temperature of 110° F. to 120° F. at 20 PSIG pressure. The above clearances are for standard bearings under normal operating conditions. Consult factory for sizes and speeds not shown and special conditions. Tolerance ± .001 for 2" diameter through 6" diameter - ± .015 for over 6" diameter.

FIG. 8 — BEARING CLEARANCE CHART

The correction is approximately one-half the bearing clearance.

It must be recognized that the motor shaft will rise as it warms up during operation. It is estimated to rise .001" per foot of shaft center line height above the motor feet.

A typical limited end float flexible coupling as used with motors having journal bearings is shown in Fig. 10.

After cold alignment is completed the low speed coupling can be assembled as follows:

1. Use plastic oil proof sealing compound to prevent leakage of lubricant around keys.

COUPLING SIZE (NOMINAL BORE)	OFFSET	ANGULAR DIM C
1-1/4	.002	.001
2	.003	.0015
2-1/2	.004	.002
3	.0045	.0025
3-1/2	.005	.0025
4	.006	.003
4-1/2	.007	.0035
5	.0075	.004
5-1/2	.0085	.004
6	.009	.0045
7	.0105	.005

For the Zurn Coupling illustrated the last number corresponds to nominal diameter. For example Zurn size 105 has nominal bore 5.

Lesser amount of misalignment in operation will prolong coupling life.

FIG. 9 — LOW SPEED COUPLING MAXIMUM MISALIGNMENT

2. Apply a small amount of grease to both seals so that they will slide easily over hub surface.

Make sure seals are not crimped or bent over, otherwise leakage of lubricant may occur at this point.

3. Clean flanges thoroughly and install gasket.
4. Draw sleeves together making sure seals are properly seated. Insert bolts and tighten to insure a tight seal between the flanges.
5. Remove both lubricating plugs with lubricating holes at 45° apply Texaco Marfak 1 or equal grease until it comes out of bottom hole. Install lubricating plugs in flange and tighten.

Clean and lubricate the coupling annually.

CHECKING HOT ALIGNMENT

After all components of the system have reached their normal operating temperatures (at least 6 hours), a hot alignment check must be made as quickly as possible while the components are near running temperatures.

A spanner device should be made so that the coupling sleeves can be bridged and indicator readings on the motor shaft and speed increaser shaft can be made at the 12, 3, 6, and 9 o'clock positions without disconnecting the coupling. Readings and correction requirements should be noted as quickly as possible before temperatures attain ambient conditions. Correction should then be made to suit hot alignment requirements.

Maximum misalignment during normal operation is shown in the table on Figure 9.

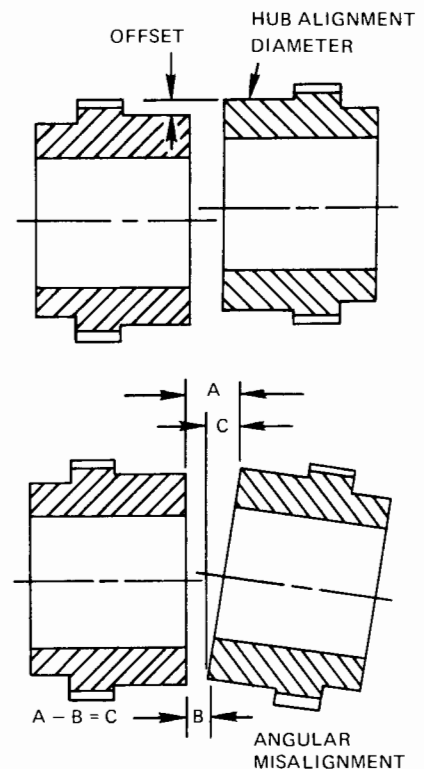



36USC380

P.O. Box 1592, York, Pennsylvania USA 17405-1592
Copyright © by York International Corporation 1997
Form 160.71-N2 (878)
Supersedes: 220.10-NM1.2 (563) &
220.10-NM1.6 (566)

Subject to change without notice. Printed in USA
ALL RIGHTS RESERVED
RPC 1M 697 .84
Code: SJ3B