

PART NO	ITEM	DESCRIPTION
022-03850	1	VALVE, STOP 3/4 NPT
023-13551	2	PIPE, 3/4 NPT X 2" LG.
022-05248	3	VALVE, MULTIPORT 3/4 NPT
026-315648	4	ELEMENT, FILTER
023-11331	5	FILTER, OIL, 3/4 NPT
022-03836	6	VALVE, STOP 3/4 X 3/4 NPT
023-11364	7	ELEND, RND FLD NPT X FLARE
023-04053	8	FLARE, PIPE 3/4-14 NPT
021-05575	9	FLARE, NUT 1/4
023-01024	10	BONNET, FLARE 1/4
024-460848	11	TUBE, BEND
021-01477	12	BRACKET
021-00466	13	SCREEN, COP HEX 3/8-16 UNC X 1
021-00466	14	NUT HEX 3/8-16 UNC-2B
021-16582	15	CONN, FLA, 3/4 O.D. X NPT
021-16584	16	WASHER, FLA
013-02954	17	0.01 INCH BRASS
023-01584	18	ELBOW, SCREEN STREET 1/4 NPT X NPT
	19	2

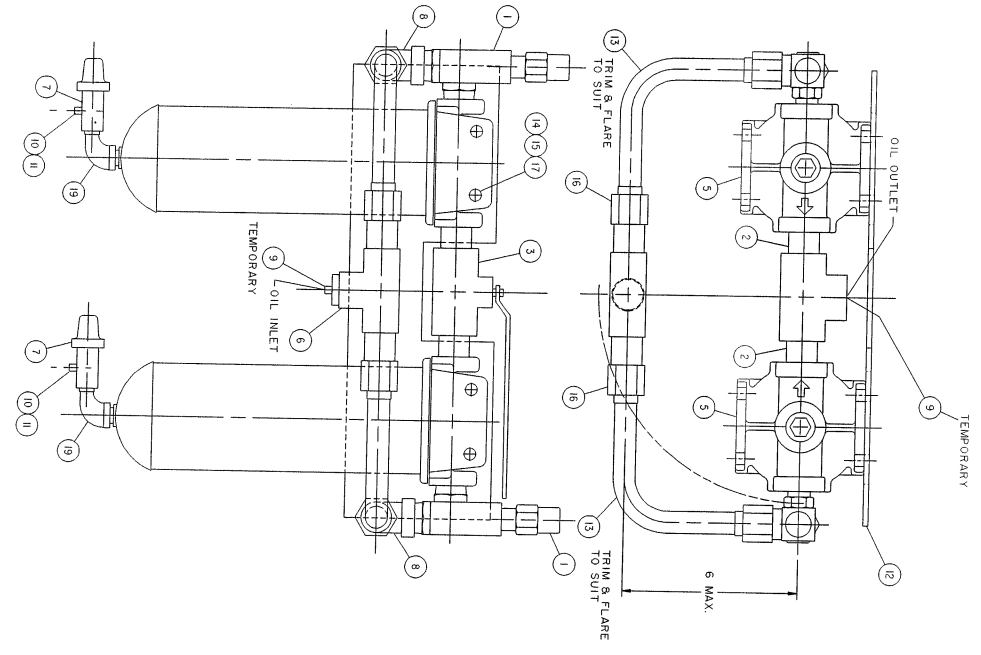

- NOTES:
- TEST AT 25 PSI AIR.
  - APPLY ITEM 18 TO ALL THREADED JOINTS 3/4" NPT AND BELOW.
  - FILTER ELEMENT, ITEM 4 MUST REMAIN WITH PACKAGE FOR REPLACEMENT AFTER SYSTEM RUN-IN TEST. THE OTHER ELEMENT REQ'D. IS PROVIDED WITH SYSTEM PIPING BILL OF MAT'L.

YORK INTERNATIONAL CORPORATION  
YORK, PA. 17405

NAME	DATE	DRAWING NUMBER
DR. J.P. WILSON	05-06-78	364-46083-000
CHK. J.P. WILSON	08-20-78	
APP. J.P. WILSON		
SIZE	CAGE NO.	PART NO.
D	66935	364-46083-000
PKG. QTY.	QTY. REQ'D.	QTY. SUPPLIED
DATE	BY	CHK.

REV. DATE	REVISION RECORD	CHK. NO.	PK. CK.	REV. DATE	REVISION RECORD	CHK. NO.	PK. CK.	REV. DATE	REVISION RECORD
2	REVISION ON CAD. ADDED ITEM 19 & NOTE 3								
1	ITEM 15 P/N WAS 003-00952. QTY WAS 2 FT.								
	ADDED NOTE TRIM AND FLARE TO SUIT AT ITEMS 13								

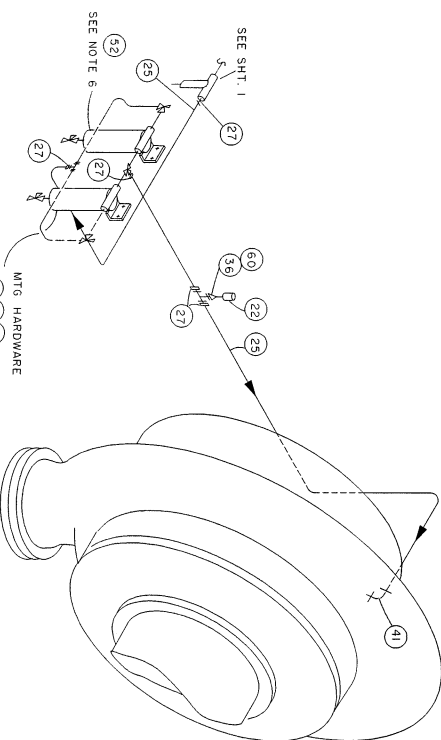

DETAIL "A"  
DUAL OIL FILTERS

DETAIL "D"  
TIRM TO SUIT

- NOTES:
- PULL ALL PIPE THREADS TOGETHER WITH STEPS ON ALL SHIPPED PARTS
  - ALLOW 1/4 INCH CLEARANCE BETWEEN TUBING LINES MAY NOT COME IN CONTACT REQUIRED. SEE DETAIL "C"
  - PLACE ITEM 42 INSIDE CONTROL PANEL.
  - LINES BEHIND DISCHARGE SHOULD BE KEPT 6 INCHES ABOVE COMPENSER SHELL.
  - REPLACE OIL FILTER CARTRIDGES WITH ITEM 29 AFTER RUN-IN TEST AND ALL TURBOPAK UNITS BEFORE SHIPMENT.
  - CLEAN OIL LINE PARTS FROM OIL FILTER TO COMPRESSOR PRIOR TO ASSEMBLY PER M-33.

SEE SHT. 1  
SEE NOTE 6  
MTG. HARDWARE (5) (58) (39)  
USING FILTER BRACKET AS IN TEMPLATE & DRILL (4) 13/32" DIA. HOLES

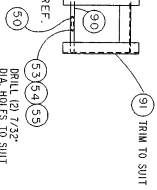

REV.	DATE	REVISION RECORD	CHK. NO.	OR.	CK.	REV. DATE
A	03-28-69	UPDATED TO CURRENT STD. FOR S.O. 92-805012	5044			
B	03-28-69	UPDATED TO CURRENT STD. FOR S.O. 93-10210-01	5044			

REV.	DATE	REVISION RECORD	CHK. NO.	OR.	CK.	REV. DATE

REV.	DATE	REVISION RECORD	CHK. NO.	OR.	CK.	REV. DATE

REV.	DATE	REVISION RECORD	CHK. NO.	OR.	CK.	REV. DATE

YORK INTERNATIONAL CORPORATION  
YORK, PA. 17403

NAME	DATE	OR. & DATE	SCALE
D	07-21-69	07-21-69	1:1

SIZE	669335	376-78671-000
TYPE	PIPING SYSTEM	REFRIGERANT-1/23
PART NO.	Y1308 THRU Y1313 SHELLS	
ENG. STD.	Y1308 THRU Y1313 SHELLS	
DRAWING NUMBER	W/OIL FILTERS	
CUT SIZE		

ALL PROPRIETARY RIGHTS HEREBY ARE RESERVED. NO PART IN WHOLE OR IN PART MAY BE REPRODUCED OR TRANSMITTED IN ANY FORM OR BY ANY MEANS WITHOUT WRITTEN PERMISSION BY YORK INTERNATIONAL CORPORATION.

OR. & DATE: 07-21-69

SCALE: 1:1

SIZE: 669335

TYPE: PIPING SYSTEM

REFRIGERANT-1/23

Y1308 THRU Y1313 SHELLS

W/OIL FILTERS

376-78671-000

DRAWING NUMBER

CUT SIZE

ENG. STD.

Y1308 THRU Y1313 SHELLS

OR. & DATE: 07-21-69

SCALE: 1:1

SIZE: 669335

TYPE: PIPING SYSTEM

REFRIGERANT-1/23

Y1308 THRU Y1313 SHELLS

W/OIL FILTERS

376-78671-000

DRAWING NUMBER

CUT SIZE

ENG. STD.

Y1308 THRU Y1313 SHELLS

OR. & DATE: 07-21-69

SCALE: 1:1

SIZE: 669335

TYPE: PIPING SYSTEM

REFRIGERANT-1/23

Y1308 THRU Y1313 SHELLS

W/OIL FILTERS

376-78671-000

DRAWING NUMBER

CUT SIZE

ENG. STD.

Y1308 THRU Y1313 SHELLS

OR. & DATE: 07-21-69

SCALE: 1:1

SIZE: 669335

TYPE: PIPING SYSTEM

REFRIGERANT-1/23

Y1308 THRU Y1313 SHELLS

W/OIL FILTERS

376-78671-000

DRAWING NUMBER

CUT SIZE

ENG. STD.

Y1308 THRU Y1313 SHELLS

OR. & DATE: 07-21-69

SCALE: 1:1

SIZE: 669335

TYPE: PIPING SYSTEM

REFRIGERANT-1/23

Y1308 THRU Y1313 SHELLS

W/OIL FILTERS

376-78671-000

DRAWING NUMBER

CUT SIZE

ENG. STD.

Y1308 THRU Y1313 SHELLS

OR. & DATE: 07-21-69

SCALE: 1:1

SIZE: 669335

TYPE: PIPING SYSTEM

REFRIGERANT-1/23

Y1308 THRU Y1313 SHELLS

W/OIL FILTERS

376-78671-000

DRAWING NUMBER

CUT SIZE

ENG. STD.

Y1308 THRU Y1313 SHELLS

OR. & DATE: 07-21-69

SCALE: 1:1

SIZE: 669335

TYPE: PIPING SYSTEM

REFRIGERANT-1/23

Y1308 THRU Y1313 SHELLS

W/OIL FILTERS

376-78671-000

DRAWING NUMBER

CUT SIZE

ENG. STD.

Y1308 THRU Y1313 SHELLS

OR. & DATE: 07-21-69

SCALE: 1:1

SIZE: 669335

TYPE: PIPING SYSTEM

REFRIGERANT-1/23

Y1308 THRU Y1313 SHELLS

W/OIL FILTERS

376-78671-000

DRAWING NUMBER

CUT SIZE

ENG. STD.

Y1308 THRU Y1313 SHELLS

OR. & DATE: 07-21-69

SCALE: 1:1

SIZE: 669335

TYPE: PIPING SYSTEM

REFRIGERANT-1/23

Y1308 THRU Y1313 SHELLS

W/OIL FILTERS

376-78671-000

DRAWING NUMBER

CUT SIZE

ENG. STD.

Y1308 THRU Y1313 SHELLS

OR. & DATE: 07-21-69

SCALE: 1:1

SIZE: 669335

TYPE: PIPING SYSTEM

REFRIGERANT-1/23

Y1308 THRU Y1313 SHELLS

W/OIL FILTERS

376-78671-000

DRAWING NUMBER

CUT SIZE

ENG. STD.

Y1308 THRU Y1313 SHELLS

OR. & DATE: 07-21-69

SCALE: 1:1

SIZE: 669335

TYPE: PIPING SYSTEM

REFRIGERANT-1/23

Y1308 THRU Y1313 SHELLS

W/OIL FILTERS

376-78671-000

DRAWING NUMBER

CUT SIZE

ENG. STD.

Y1308 THRU Y1313 SHELLS

OR. & DATE: 07-21-69

SCALE: 1:1

SIZE: 669335

TYPE: PIPING SYSTEM

REFRIGERANT-1/23

Y1308 THRU Y1313 SHELLS

W/OIL FILTERS

376-78671-000

DRAWING NUMBER

CUT SIZE

ENG. STD.

Y1308 THRU Y1313 SHELLS

OR. & DATE: 07-21-69

SCALE: 1:1

SIZE: 669335

TYPE: PIPING SYSTEM

REFRIGERANT-1/23

Y1308 THRU Y1313 SHELLS

W/OIL FILTERS

376-78671-000

DRAWING NUMBER

CUT SIZE

ENG. STD.

Y1308 THRU Y1313 SHELLS

OR. & DATE: 07-21-69

SCALE: 1:1

SIZE: 669335

TYPE: PIPING SYSTEM

REFRIGERANT-1/23

Y1308 THRU Y1313 SHELLS

W/OIL FILTERS

376-78671-000

DRAWING NUMBER

CUT SIZE

ENG. STD.

Y1308 THRU Y1313 SHELLS

OR. & DATE: 07-21-69

SCALE: 1:1

SIZE: 669335

TYPE: PIPING SYSTEM

REFRIGERANT-1/23

Y1308 THRU Y1313 SHELLS

W/OIL FILTERS

376-78671-000

DRAWING NUMBER

CUT SIZE

ENG. STD.

Y1308 THRU Y1313 SHELLS

OR. & DATE: 07-21-69

SCALE: 1:1

SIZE: 669335

TYPE: PIPING SYSTEM

REFRIGERANT-1/23

Y1308 THRU Y1313 SHELLS

W/OIL FILTERS

376-78671-000

DRAWING NUMBER

CUT SIZE

ENG. STD.

Y1308 THRU Y1313 SHELLS

OR. & DATE: 07-21-69

SCALE: 1:1

SIZE: 669335

TYPE: PIPING SYSTEM

REFRIGERANT-1/23

Y1308 THRU Y1313 SHELLS

W/OIL FILTERS

376-78671-000

DRAWING NUMBER

CUT SIZE

ENG. STD.

Y1308 THRU Y1313 SHELLS

OR. & DATE: 07-21-69

SCALE: 1:1

SIZE: 669335

TYPE: PIPING SYSTEM

REFRIGERANT-1/23

Y1308 THRU Y1313 SHELLS

W/OIL FILTERS

376-78671-000

DRAWING NUMBER

CUT SIZE

ENG. STD.

Y1308 THRU Y1313 SHELLS

OR. & DATE: 07-21-69

SCALE: 1:1

SIZE: 669335

TYPE: PIPING SYSTEM

REFRIGERANT-1/23