

# MOISTURE INDICATORS

## Dri-Vue, Single and Double Port

The function of a Moisture Indicator is to provide visual indication of moisture level in a refrigerant system.

### Applications

Henry Technologies' offers Dri-Vue Moisture Indicators with ODS and SAE Flare connections for use on air conditioning and refrigeration systems. The moisture level in the refrigerant system needs to be monitored to ensure excessive moisture, which could allow harmful acid formation, is not present.

Henry Technologies' Dri-Vue Moisture indicators designed for use with specific HFC and HCFC refrigerants and their associated oils as listed in the Dri-Vue Color Table.

### Main Features

- Patented Henry Technologies' Design\*
- SAE Flare connections
- ODS connections
- Positive color contrast: Yellow = Wet, Green = Dry
- Replaceable cap with built-in moisture indicator. Part Number MI-3

### Technical Specifications

Maximum working pressure = 500 PSI (34.4 Bar)

Allowable operating temperature = +15°F to +200°F (-10°C to +93°C)

Henry Technologies' Moisture Indicators are UL and C-UL Listed by Underwriters Laboratories, Inc.

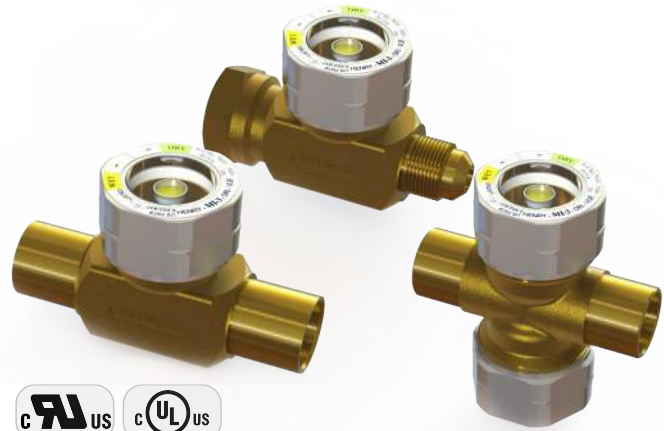

### Materials of Construction

The Moisture Indicator bodies are made of forged brass. The Dri-Vue moisture indicating cap is made of plated steel with a hermetically sealed soda lime glass lens. The cap seal is made of Teflon.

### Installation - Notes

1. ODS series Moisture Indicators must be taken apart for brazing.
2. Full instructions are given in the Product Instruction Sheet, included with each Indicator.

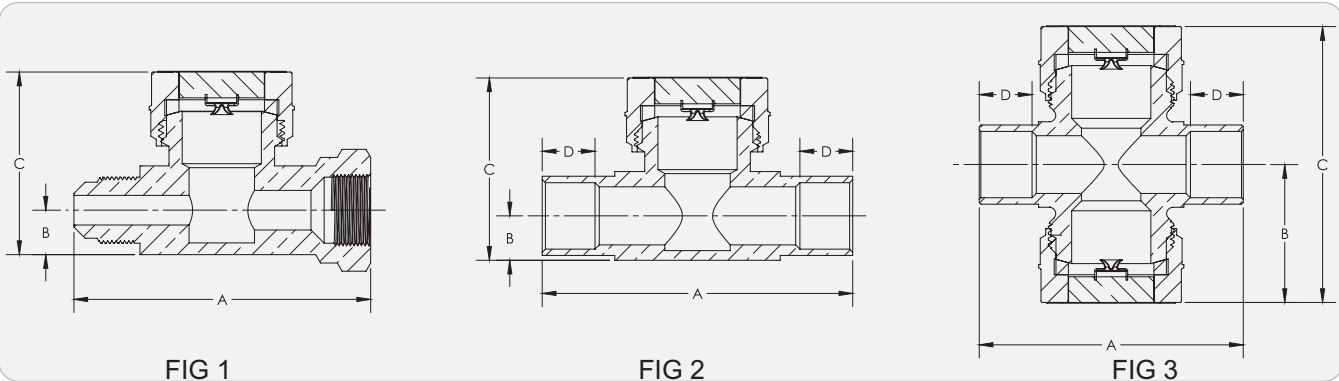

Type	Part No	Fig No	Conn Size (inch)	Dimensions (inch)				Weight (lbs)
				A	B	C	D	
MI-30-F	MI-30-1/4F	1	1/4 SAE Flare	2.63	0.34	1.51	N/A	0.43
	MI-30-3/8F	1	3/8 SAE Flare	2.81	0.45	1.71	N/A	0.57
	MI-30-1/2F	1	1/2 SAE Flare	3.13	0.41	1.65	N/A	0.59
MI-30-S	MI-30-1/4S	2	1/4 ODS	2.63	0.34	1.51	0.31	0.40
	MI-30-3/8S	2	3/8 ODS	2.63	0.34	1.51	0.31	0.41
	MI-30-1/2S	2	1/2 ODS	2.63	0.34	1.51	0.38	0.41
	MI-30-5/8S	2	5/8 ODS	2.94	0.45	1.71	0.50	0.46
MI-31-S	MI-31-5/8S	3	5/8 ODS	2.50	1.30	2.60	0.50	0.69

Dri-Vue Color Table				
Refrigerant Type	Temp (°F)	Moisture PPM - Indicator color		
		Green	Chartreuse	Yellow
R404A	75	below 15	15-90	above 90
	100	below 25	25-115	above 115
	125	below 30	30-140	above 140
R22/R134a	75	below 30	30-120	above 120
	100	below 45	45-180	above 180
	125	below 60	60-240	above 240