

# BALL VALVES

The function of a Ball Valve is to provide isolation in liquid and gas applications with single or bi-directional flow where little restriction is desired.

## Applications

Ball valves are used in a wide variety of refrigeration and air conditioning applications. They can be used for both liquid and gas applications. This type of valve is commonly used for isolating purposes. 937 series ball valves are suitable for use with HCFC and HFC refrigerants and their associated oils, as well as other industrial fluids non-corrosive to brass, steel, copper, Teflon and synthetic rubber.

## Main Features

### Construction features

- Bi-directional flow
- ODS connections
- Indicator on stem shows valve position - open or closed
- Fully opened or closed with quarter turn of stem
- Positive stem stop ensures precise positioning in the open or closed position
- Blow-out proof stem
- Ball cavity vented to prevent over-pressure
- Schrader valve included
- Mounting pad

### Sealing integrity features

- Premium quality PTFE ball seals
- Double O-ring stem seal design
- Premium quality neoprene stem O-ring seals
- Neoprene cap seal - acts as a secondary seal

### Technical Specifications

Maximum working pressure = 700 PSI (48.3 Bar)

Allowable operating temperature = -40°F to +250°F (-40°C to +121°C)

Henry Technologies' 937 Series Ball Valves are UL and C-UL Listed by Underwriters Laboratories, Inc. Valves 1-3/8 and larger are CE marked in accordance with PED. Additionally, the Ball Valves are designed and registered for use in Canada. Please contact Technical Support at 1-800-627-5148 for CRN details and list of approved provinces and territories.

### Materials of Construction

The components: valve body, valve body adaptor, ball and seal cap are made from brass. The stem is made from plated steel. The pipe extensions are made from copper. The ball seals are made from virgin PTFE, stem O-rings and cap seal from neoprene.



CRN



CE

### Installation - Notes

1. The valve body must be protected against excessive heat during installation, to prevent damage to the seals.
2. Full instructions are given in the Product Instruction Sheet, included with each valve.

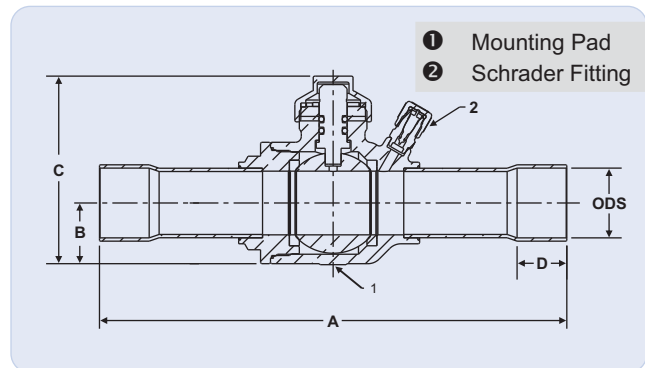

Part No	ODS (inch)	Dimensions (inch)				Port Size (inch)	Cv	Weight (lbs)
		A	B	C	D			
937202	1/4	6.50	0.63	2.15	0.31	0.50	2.09	0.75
937203	3/8	6.50	0.63	2.15	0.31	0.50	2.44	0.75
937204	1/2	6.50	0.63	2.15	0.39	0.50	6.01	0.77
937205	5/8	6.50	0.63	2.15	0.51	0.50	15.1	0.77
937307	7/8	7.24	0.83	2.63	0.79	0.75	42.0	1.46
937409	1 1/8	8.50	1.00	2.97	0.94	1.00	82.5	2.14
937511	1 3/8	9.25	1.22	3.73	0.98	1.25	142.2	3.48
937613	1 5/8	10.00	1.54	4.24	1.10	1.50	220.8	5.56
937617	2 1/8	11.42	1.87	5.26	1.38	2.00	438.9	10.14
937721	2 5/8	12.87	1.87	5.26	1.50	2.00	224.5	11.35
937725	3 1/8	14.37	2.36	6.06	1.69	2.50	373.2	19.38