

IMPORTANT!

READ BEFORE PROCEEDING!

GENERAL SAFETY GUIDELINES

This equipment is a relatively complicated apparatus. During installation, operation, maintenance or service, individuals may be exposed to certain components or conditions including, but not limited to: refrigerants, oils, materials under pressure, rotating components, and both high and low voltage. Each of these items has the potential, if misused or handled improperly, to cause bodily injury or death. It is the obligation and responsibility of operating/service personnel to identify and recognize these inherent hazards, protect themselves, and proceed safely in completing their tasks. Failure to comply with any of these requirements could result in serious damage to the equipment and the property in which it is situated,

as well as severe personal injury or death to themselves and people at the site.

This document is intended for use by owner-authorized operating/service personnel. It is expected that this individual possesses independent training that will enable them to perform their assigned tasks properly and safely. It is essential that, prior to performing any task on this equipment, this individual shall have read and understood this document and any referenced materials. This individual shall also be familiar with and comply with all applicable governmental standards and regulations pertaining to the task in question.

SAFETY SYMBOLS

The following symbols are used in this document to alert the reader to areas of potential hazard:



DANGER indicates an imminently hazardous situation which, if not avoided, will result in death or serious injury.

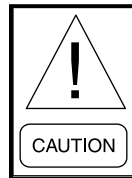

CAUTION identifies a hazard which could lead to damage to the machine, damage to other equipment and/or environmental pollution. Usually an instruction will be given, together with a brief explanation.



WARNING indicates a potentially hazardous situation which, if not avoided, could result in death or serious injury.

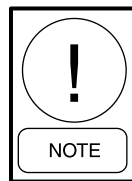

NOTE is used to highlight additional information which may be helpful to you.

CHANGEABILITY OF THIS DOCUMENT

In complying with YORK's policy for continuous product improvement, the information contained in this document is subject to change without notice. While YORK makes no commitment to update or provide current information automatically to the manual owner, that information, if applicable, can be obtained by contacting the nearest YORK Engineered Systems Group office.

It is the responsibility of operating/service personnel as to the applicability of these documents. If there is any question in the mind of operating/service personnel as to the applicability of these documents, then, prior to working on the equipment, they should verify with the owner whether the equipment has been modified and if current documentation is available.

SUMMARY OF CHANGES

- 101 Original Release
 1203 Included information from Literature Supplements.
 Included third port information for remote monitoring.

REFERENCE INSTRUCTIONS

DESCRIPTION	FORM NO.
Modbus MicroGateway Specifications	450.20-S19
Modbus MicroGateway Installation	450.20-N1
Renewal Parts List	450.00-RP1

TABLE OF CONTENTS

GENERAL SAFETY GUIDELINES	2
CHANGEABILITY OF THIS DOCUMENT	3
REFERENCE INSTRUCTIONS	3
SECTION 1 – GENERAL INFORMATION	9
Overview.....	9
Quick Start.....	9
CLIP	10
Firmware.....	10
Port Configuration.....	10
Summary of Functionality	12
Theory of Operation.....	12
Configuration Mode	13
Operation Mode	13
SECTION 2 – COMMUNICATION.....	15
General.....	15
Port 1	15
Port 2	15
Port 3	15
Accessing the Firmware	16
Connecting the Computer.....	16
Logon Procedure	16
Changing to Operation Mode	19
SECTION 3 – SOFTWARE	21
Default Settings	21
Quick Start.....	21
Quick Start Settings Table	21
Power Up/Power Down Sequence	21
Quick Start 245	23
Quick Start 244	23
Quick Start 243	23
Quick Start 128	24
E ² Default Settings.....	26
Customizing the EPROM.....	26
Feature Set	29
Example.....	30
F58 – E ² (EEPROM) Setup	31
F59 – E ² (EEPROM) Data	31

TABLE OF CONTENTS (CONT)

F70 – Port Setup	31
F71 – Statistics Setup.....	33
F72 – Mod York Talk 1 & F73 – Mod York Talk 2	35
General	35
F74 – Mod York Talk 3	38
F75 – Range.....	42
Range and Scale Theory.....	42
Scale.....	42
Range (F75).....	43
Chiller Read Points	43
Chiller Write Points	44
Modbus Registers.....	45
SECTION 4 – HARDWARE.....	49
GENERAL	49
STATUS LED	49
Normal Operation	49
Advisory Conditions.....	49
Failures	49
Port LEDs	50
Port 1 LEDs	50
Port 2 LEDs	51
Dimly Lit LEDs	51
Communications During Quick Start.....	51
Updating Firmware	51
Part Replacement.....	52
Chip Replacement	52
Fuse Replacement.....	53
Power Board Replacement.....	53
Circuit Board Replacement.....	54

TABLE OF CONTENTS (CONT)

- SECTION 5 – TROUBLESHOOTING 57
 - Error Processing 57
 - Special Registers..... 57
 - Modbus View 58
 - York Talk Status (401) 58
 - Data Overflow (402)..... 58
 - Time and Date Registers (404, 405 & 413) 58
 - Timing Registers (406 & 407) 58
 - Mode Register (410) 58
- APPENDIX 61

FIGURE LIST

Figure 1. Theory of Operation	11
Figure 2. MicroGateway to Computer Cable	15
Figure 3. Power Harness at J1	16
Figure 4. Configure ISNtools Screen.....	17
Figure 5. Network Selection Screen	17
Figure 6. ISNtools Screen	18
Figure 7. Setting the Node Switch.....	23
Figure 8. Communications Test Connections	24
Figure 9. E ² Operational Theory	25
Figure 10. EPROM Creation	28
Figure 11. Slope Calculation	42
Figure 12. EPROM Orientation	52
Figure 13. RS485 Drivers	52
Figure 14. Power Board Connections.....	54
Figure 15. Circuit Board Components	55

TABLE LIST

Table 1 – Maximum Query Size..... 12

Table 2 – Default Settings.....21

Table 3 – Quick Start Settings22

Table 4 – Feature List29

Table 5 – Port 1 Protocols.....32

Table 6 – Port 2 Protocols.....32

Table 7 – Chiller Types.....34

Table 8 – York Talk Point Types35

Table 9 – York Talk 3 Poll Rates39

Table 10 – York Talk 3 Status Codes39

Table 11 – Scale Field Values.....43

Table 12 – Modbus Range.....45

Table 13 – Modbus Inputs and Registers45

Table 14 – Modbus Function 17.....46

Table 15 – LED Flash Rates50

Table A-1 – Sample York Talk Points List62

SECTION 1

GENERAL INFORMATION

Overview

The Modbus MicroGateway is a communications device that allows any York chiller that supports one of the three York Talk protocols to be connected to a Modbus network using the Modbus RTU protocol. There are several variations of the Modbus MicroGateway, depending upon the number of ports, type of input voltage, and the chiller which it will be connected to.

MicroGateways with Quick Start are available with two or three ports. Port 1 connects to the chiller panel, Port 2 connects to the Modbus network or a VT100 terminal (for custom configuration), and Port 3, if equipped, connects to a second Modbus RTU network. Port 3, located on a daughter board or CLIP, is used for monitoring only and does not allow any control.

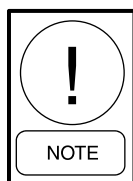

NOTE: Throughout this manual, the *CLIP* refers to the daughter board with the third port. Reference to the *MicroGateway* always refers to the 031-02039-xxx circuit board and may or may not include the *CLIP* and power supply.

For chillers using the OptiView micro panel, the Modbus MicroGateway consists of a single circuit board attached to four studs inside the micro panel. The 12 volt DC input power is drawn directly from the OptiView micro panel, eliminating the need for an external power supply.

For other types of chillers, the Modbus MicroGateway comes with its own enclosure. In addition to the MicroGateway circuit board, a power board is included inside the enclosure to convert input line voltage (115 or 230 volts AC) to 12 volt DC power.

A series of LEDs provide information about the Modbus MicroGateway's communication and operating status. Each port has a red transmission LED (TX) and a green receiving LED (RX). A STATUS LED provides information regarding the associated board to verify proper setup selection, as well as indicating normal operation and the presence of errors.

Quick Start

The Modbus MicroGateway uses a feature referred to as "Quick Start" to provide a simple configuration method to set parameters for popular chillers. Quick Start is implemented by setting the node switch to a number that loads a profile and sets the communications parameters for a particular chiller type.

Quick Start also allows a technician to select Configuration Mode (terminal mode) for computer communications, select metric or imperial units, and run a basic "loop back" communications test.



CAUTION: The procedure for setting the *CLIP* requires the use of the Quick Starts. If the *MicroGateway* is intended for customized programming beyond the scope of the Quick Start features, the Modbus Server functionality of the *CLIP* is overridden.

The Quick Start profile is stored in the nonvolatile, electrically erasable memory of the MicroGateway called E². The nonvolatile data remains in E² until overwritten by a different Quick Start selection. If the new Quick Start profile invoked does not overwrite a particular attribute in a given feature, the attribute from the previous Quick Start setting remains.

Changing the node switch to the network address will not remove the Quick Start information from the E² memory.

When the node switch is set to a Quick Start address, the STATUS LED flashes the appropriate number of times to signify that the selection is made. The STATUS LED continues to flash as long as the node address remains set for the Quick Start selection.

CLIP

MicroGateways can be ordered in two or three port configurations. A daughter board (CLIP) provides the third port, allowing any MicroGateway to operate as a Modbus Server to a second, third-party Modbus RTU system. This second system is limited to monitoring only as the CLIP will not allow any Write functions.

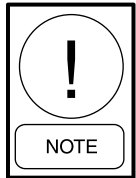

NOTE: This manual is intended to guide the user through customization of the Modbus MicroGateway. Use of the CLIP contradicts customization of the MicroGateway. The Installation Manual covers the Quick Start setup procedures and should be used when the third port is used. Limited reference is made to the third port and CLIP in this document.

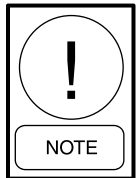

NOTE: The daughter board (CLIP) is not field-installable. The third port must be factory-installed.

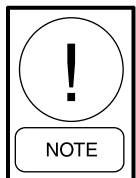

NOTE: Information regarding the collection of the Modbus RTU data is a function of the remote monitoring system and is outside the scope of this manual.

Firmware

The Modbus MicroGateway uses firmware specifically designed for Modbus operation. The firmware is designated as MDC88nn (where nn defines the version number).

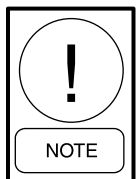

NOTE: The CLIP firmware is designated as RMD88nn.

Port 2 of the Modbus MicroGateway operates as a SERVER that responds to Modbus RTU commands only. It does not have the capability to initiate an unsolicited communication session, i.e. it cannot become a Modbus MASTER. The Modbus software

is able to connect to any of York’s chiller types using one of the three York Talk protocols.

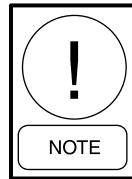

NOTE: This product does not support ISN communications. It associates York Talk data to Modbus Registers.

Port Configuration

The software is designed to be port specific. Port 1, located on the MicroGateway base board, supports connections to the York Talk protocols.

- York Talk 1 – RS232 connection (TB3)
- York Talk 2 – RS485 connection (TB1)
- York Talk 3 – RS232 connection (TB3)

Port 2, located on the MicroGateway base board, is used to interface with the Modbus Client and to support a terminal session.

- Modbus – RS485 connection (TB2)
- Modbus or Terminal – RS232 connection (TB4)

Port 3, located on the daughter board, is used to interface with a remote monitoring device using Modbus RTU.

- Modbus – RS485 connection (TB2)
- Modbus or Terminal – RS232 connection (TB4)

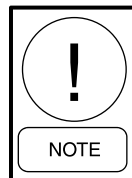

NOTE: The two connectors located on the daughter board (CLIP) are labeled TB2 and TB4, which is the same as Port 2 on the MicroGateway board.

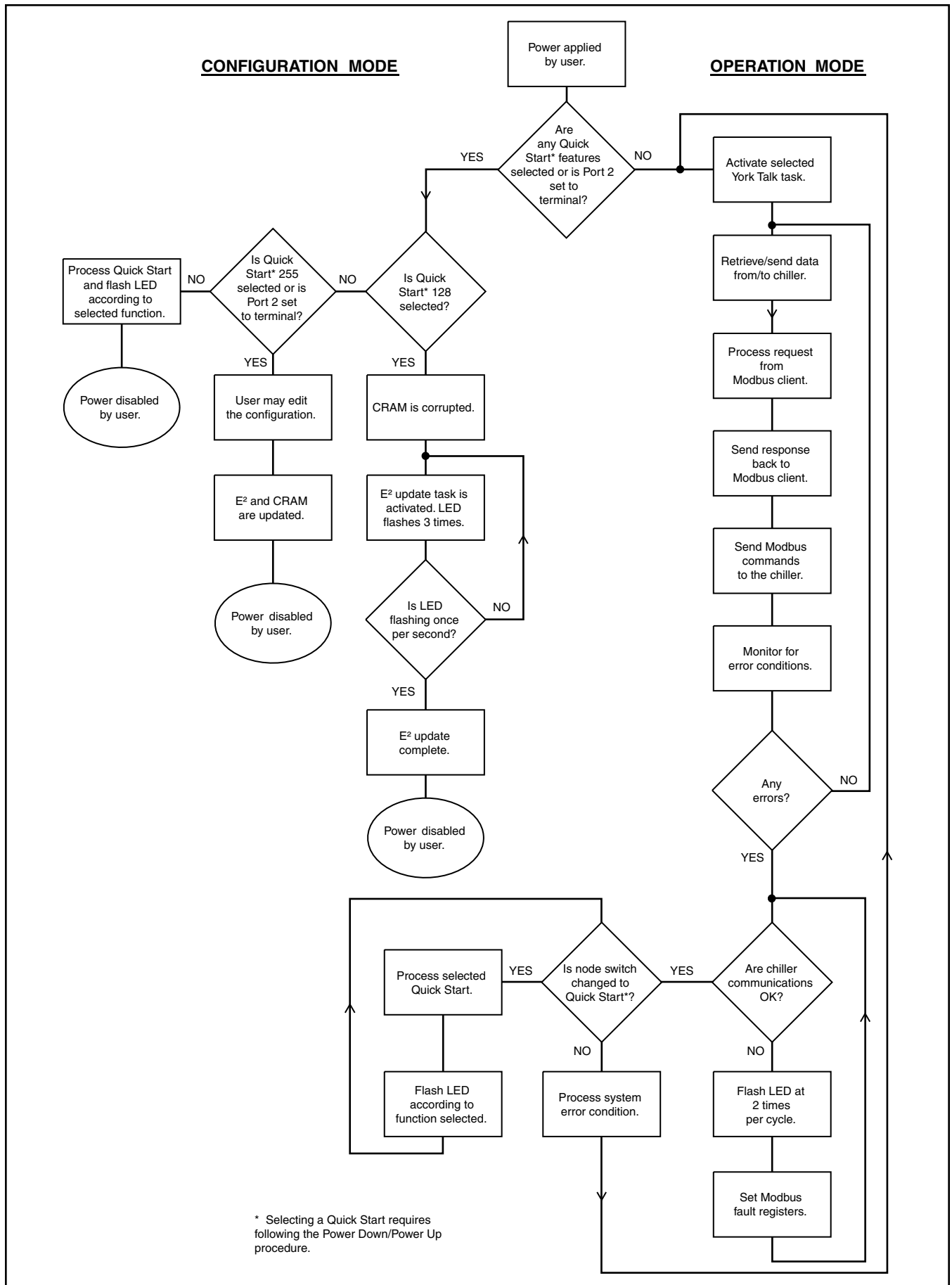

Figure 1. Theory of Operation

Table 1 – Maximum Query Size

FUNCTION	DESCRIPTION	QUERY	RESPONSE
1	Read Coil Status	800 Coils	800 Coils
2	Read Input Status	800 Inputs	800 Inputs
3	Read Holding Registers	100 Registers	100 Registers
4	Read Input Registers	100 Registers	100 Registers
15	Force Multiple Coils	800 Coils	800 Coils
16	Preset Multiple Registers	100 Registers	100 Registers

Summary of Functionality

The Modbus interface may be configured to operate at either 9600 or 19200 baud and has a configurable parity. The number of stop bits is set at 1 for Port 2 and set at 2 for Port 3. It may also be used with an RS232 or RS485 physical layer.

The following Modbus Function codes are supported:

- 01 Read Coil Status
- 02 Read Input Status
- 03 Read Holding Registers
- 04 Read Input Register
- 05 Force Single Coil
- 06 Preset Single Register
- 08 Diagnostics
- 15 Force Multiple coils
- 16 Preset Multiple Registers
- 17 Report Slave ID

The Modbus MicroGateway processes messages that are not greater than 256 bytes in length. Table 1 defines the maximum number of queries and responses that may be satisfied.

If a query is received that exceeds the maximum specifications, the Modbus MicroGateway:

- a) ignores the message if it is greater than 256 bytes.
- b) returns an exception Code 2 if the specified number of parameters is greater than the MicroGateway is capable of processing (refer to the Table 1).

The Modbus MicroGateway network address may be set to any number between 0 and 200 excluding 128. Addresses 128 and 201 to 255 are reserved for Quick Start configuration purposes.

Theory of Operation

The Modbus MicroGateway is a microprocessor-based communications device that translates between two serial protocols. It uses a memory organization that allows data to be stored according to the functional needs of the system. The base operating program, the operating system and all associated routines that cannot be altered by the user or by the system during normal operation are stored in the EPROM.

EPROM (Electrically Programmable Read Only Memory) – This module stores the software code. All options for communications and all tables are stored in the EPROM. The information is “burned” into the module at the factory and is not editable.

A qualified York engineer may sometimes be provided with a HEX or BIN file that contains upgraded software. The upgraded software may be loaded in the EPROM by first using a UV eraser to remove the current data and then burning the new file into the EPROM.

SRAM (Static Random Access Memory) – The SRAM can be partitioned into two parts; the VRAM and CRAM. VRAM is the systems “scratch pad” and its contents are reset every time the MicroGateway is reset or powered up. CRAM is backed up by a capacitor and maintains its contents for approximately 72 hours. CRAM is used to maintain any user or system entered parameters.

While CRAM provides a time limited nonvolatile storage environment, in many cases this is not sufficient. To address this issue, E² is provided.

E² or EEPROM (Electrically Erasable Programmable Read Only Memory) – This memory device stores certain program parameters, such as Quick Start settings.

Information is electrically written to E² and can only be edited if the software calls for a different configuration to be written.

When the system is powered up or after a system reset, the Modbus MicroGateway determines its mode of operation. There are two modes of operation; Configuration Mode and Operation Mode. Both modes are monitored by a Watchdog Circuit that resets the system if any unusual errors are detected.

Configuration Mode

The Configuration Mode is entered if the node switch is set to any number between 200 and 255 or if Port 2 is set for Configuration Mode (factory default setting). The node switch is used to select the Quick Start features.

When invoked, a Quick Start feature configures the MicroGateway for a specific type of chiller. The parameters selected include the communications protocol, baud rate, parity, etc. required by the type of Quick Start selected. In addition, the Quick Start pre-loads any other parameters needed for a particular configuration, such as scaling and micro-objects (as used by York Talk 3), etc.

Besides the Quick Start features, the MicroGateway may be setup using the terminal interface. A terminal interface is more extensible, allowing for functionality to be added that is not contained within the Quick Start features.

While in the configuration mode, the MicroGateway continues to collect and process data from any micro panel that it is connected to. This continues unless overwritten by a new setting, either through a Quick Start or terminal command.

Operation Mode

The Operation Mode uses two asynchronous tasks to expose chiller data to a Modbus client. One task interfaces directly with the chiller micro panel using the York Talk protocol. It is responsible for retrieving information from the chiller micro panel and sending any newly received commands to the chiller micro panel.

The other task services and processes Modbus queries, accepting any new requests and sending requested data.

In the Operation Mode, the MicroGateway continuously updates a data lookup table with current data from the “York Talk” task. This table has an index which correlates to the Modbus register address embedded within the Modbus Query message. This address is used to uniquely identify the data required in the Modbus Response message.

THIS PAGE INTENTIONALLY LEFT BLANK

SECTION 2

COMMUNICATION

General

Communications to the Modbus MicroGateway are provided through three ports. Each port has two connectors, one for RS232 and one for RS485. Port 1 is always connected to the chiller micro panel and Port 2 is connected to the Modbus network. Port 2 is also used when connecting a computer to the MicroGateway to configure it for a specific application. Port 3, if equipped, is located on the daughter board and is used for remote monitoring.

Port 1

Port 1 is connected to the chiller and communicates using one of the York Talk protocols. Several variants of York Talk are available. Each chiller model requires a specific type of York Talk (1, 2 or 3)

protocol, the selection of a physical driver (RS232 or RS485), and a communication baud rate. For Port 1, TB1 supports RS485 and TB3 supports RS232.

Port 2

Port 2 is connected to the Modbus RTU network. It can be connected using RS485 (TB2) or RS232 (TB4). Port 2 (TB4) is also used to connect to terminal.

Port 3

Port 3 is connected to a second Modbus RTU network. It can be connected using RS485 (TB2) or RS232 (TB4). Port 3 is not configurable other than through the Quick Start features. Port 3 only allows read commands. Write commands are not accepted.

2

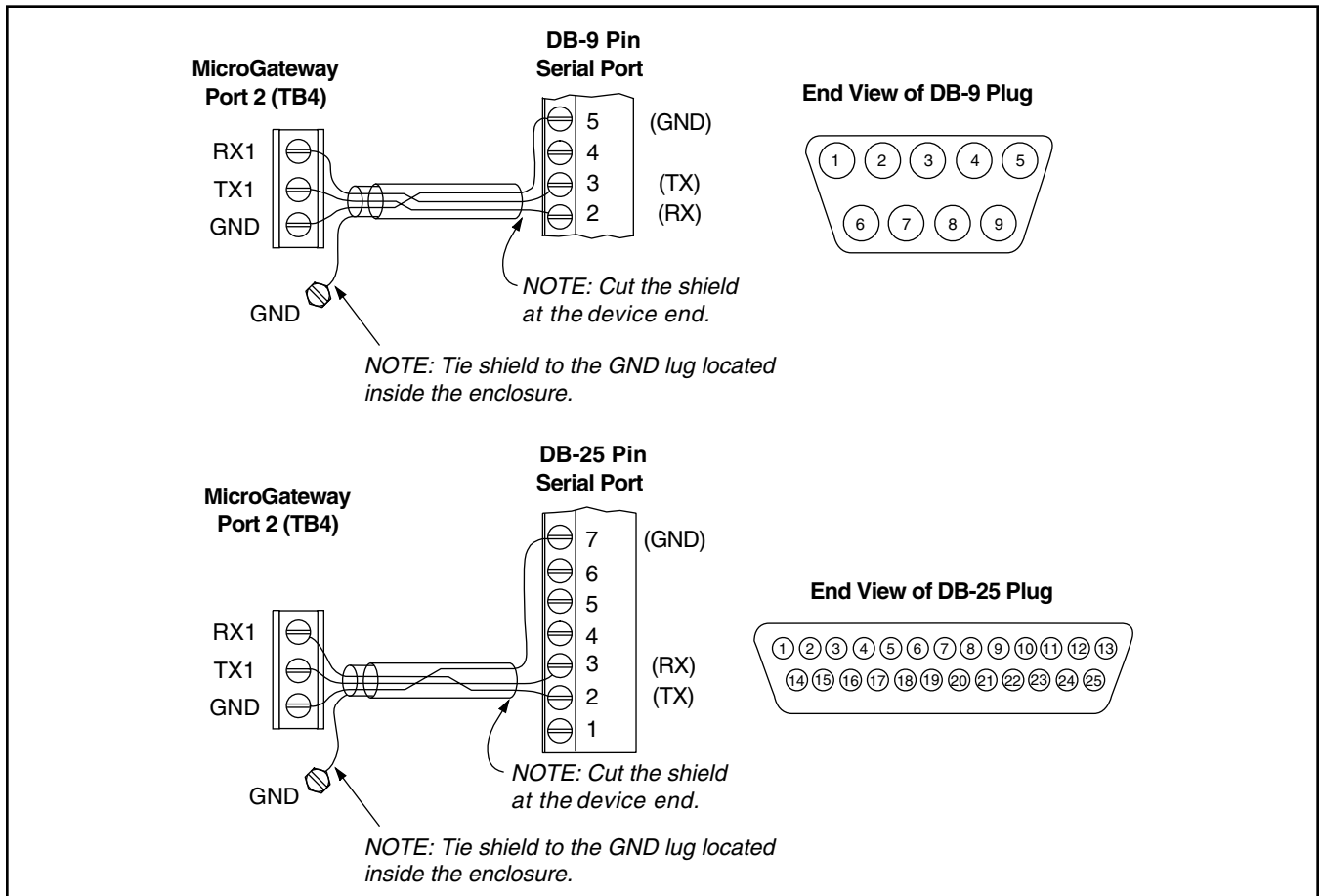
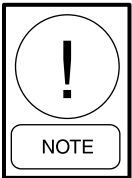

Figure 2. MicroGateway to Computer Cable

Accessing the Firmware

To access the firmware a computer or VT100 terminal is required. The computer must be capable of emulating a VT100 terminal.

The MicroGateway Configurator (ISNtools), available from YORK, emulates a VT100 terminal and allows access to most YORK control products using most Microsoft Windows® operating systems. Other third-party programs are available but may require special setup.



NOTE: For additional information regarding VT100 emulation software, contact the YORK Building Automation Services Group.

Connecting the Computer

The computer is connected to Port 2 (TB4) via a 3-wire cable. Typically the computer uses COM 1 or COM 2 to communicate with serial devices similar to the MicroGateway. Most computers use a DB-9 or DB-25 connector to provide the RS232 serial connection.

Wire the cable as shown in Figure 1 using either the DB-9 or DB-25 connector, as appropriate for the computer.

Logon Procedure

Once the computer and Modbus MicroGateway are connected, the terminal emulation software must be set to the following:

Baud rate = 9600
 Parity = None
 Data format = 8 bits, 1 stop bit

The following procedure provides specific instructions for connecting to the MicroGateway using the MicroGateway Configurator (ISNtools) which should be installed on the computer. For other types of emulation software, refer to the specific documentation for that software.

1. On the MicroGateway remove the power harness from **J1** to disconnect power.

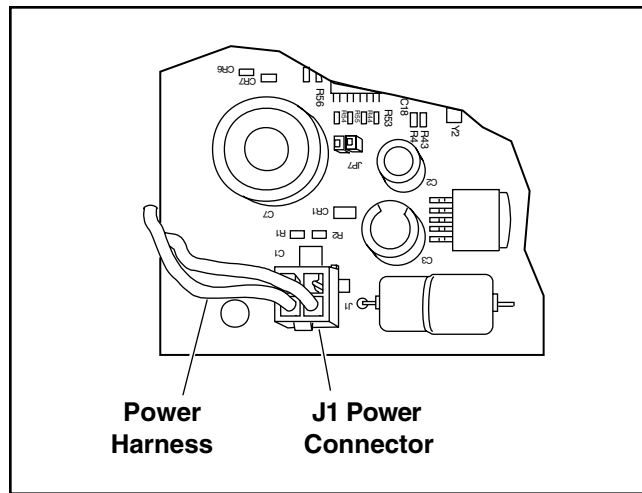
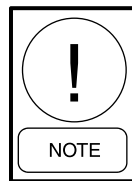
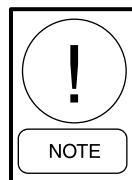

Figure 3. Power Harness at J1



NOTE: If a network address is already chosen, make a note of the node address before making changes.

2. Set the node switch on the MicroGateway to **255**.



NOTE: Setting the node switch to **255** on the MicroGateway places the MicroGateway in Configuration Mode, setting Port 2 to 9600 baud with 8 data bits, no parity.

3. Reconnect the power harness to **J1** to connect power. The MicroGateway will power up in Configuration Mode (terminal emulation).
4. After about 10 seconds, remove the power harness from **J1** to disconnect power.
5. Set the node switch to the Modbus network address noted prior to step 2. If an address has not been selected, it should be chosen at this time.
6. Reconnect the power harness to **J1** to connect power. The MicroGateway will remain in Configuration Mode during power up.

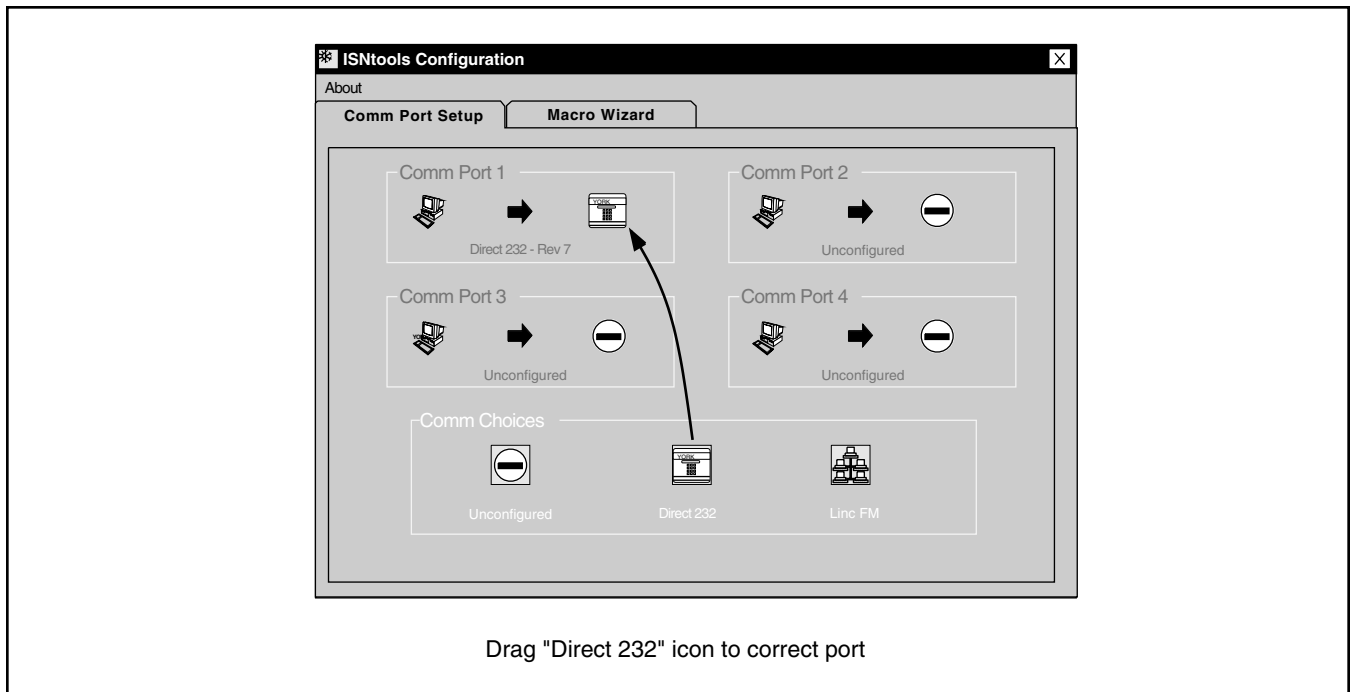
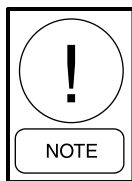

Figure 4. Configure ISNtools Screen



NOTE: *If a Quick Start address is inadvertently selected, any saved configurations may be overwritten. Always remove power to the MicroGateway before changing the node switch.*

7. On the computer, point to **Start, Programs** and select **ISNtools**. A **Sunflake** icon appears on the lower right side of the task bar.
8. Right-click on the **Sunflake** icon next to the clock on the taskbar. Click **Configure ISNtools** on the pop-up menu.
9. Drag the **Direct 232** icon over the appropriate computer port.
10. The Port Parameters box appears at the bottom of the screen to verify the communication settings. From the **Protocol** drop-down menu, select **7**.
11. For an advanced user, additional communication settings may be chosen at this time.
12. After all protocol options have been selected, click the **Accept Port Parameters** button. The PC port is now configured.
13. Click the X (close button) in the upper right corner of the window to close the configuration module of the program.

14. Right-click on the **Sunflake** icon. Click **Run Configurator** on the pop-up menu.
15. Click **OK** when the “Welcome...” dialog box appears.
16. When the Network Selection Screen appears, click **Rev. 7 Direct**.

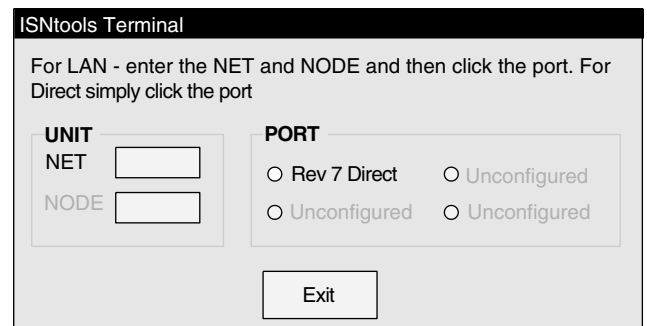
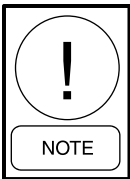

Figure 5. Network Selection Screen



NOTE: Commands may be typed into the Command field. Refer to the figure titled *ISNtools Screen*. Always use lower case when entering commands for the *MicroGateway Configurator*. Use upper case when typing labels for text fields.

- Click **Logon** or, in the Command field, type **logon <Return>**

The following appears on the screen:

PLEASE ENTER PASSWORD

- Click **Password** or, in the Command field, type **5555**

The following appears on the screen:

MODBUS 0000 SAT 01-JAN-2000 00:01

After successfully logging on to the MicroGateway, a user may navigate through the firmware using the standard Feature-Section-Page methodology. The configurations and data may be viewed and any editable field may be changed.

Refer to Section 3 – Software for information on the Features available within the Modbus MicroGateway firmware and how to use the Feature-Section-Page navigation method.

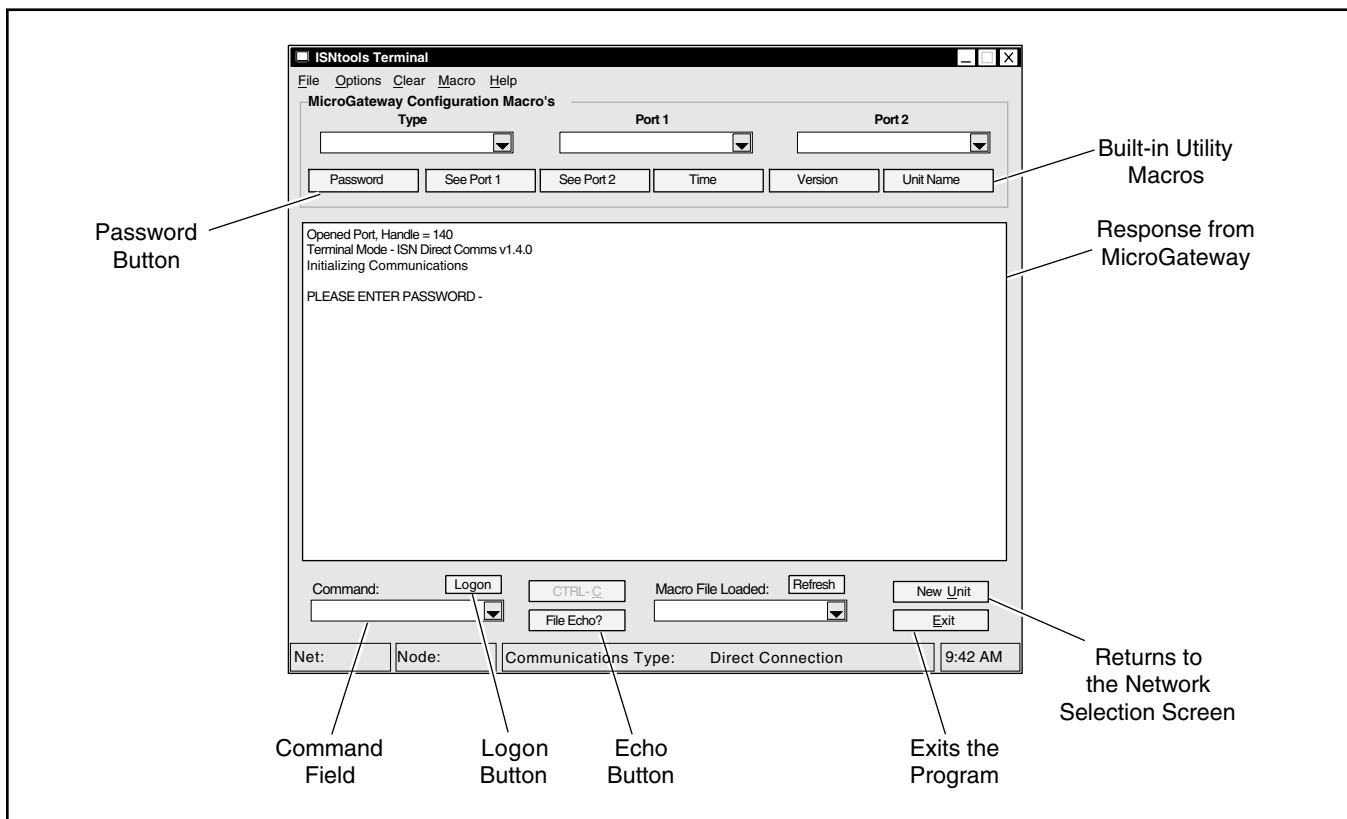

Figure 6. ISNtools Screen

Changing to Operation Mode

To return the MicroGateway to an operational mode:

1. Set the node switch to the required Modbus network address if not already selected.
2. In Feature 70 Page 04, change the Port 2 communications protocol to the desired Modbus setting. Type

f70p04

The following appears on the screen:

P04 PORT 2 PROTOCOL: TERMINAL

3. Enter the edit mode of the page by typing

e <Return>

The following appears on the screen:

P04 PORT 2 PROTOCOL: mmmmmmm

where mm..m signifies a menu list.

4. Select the desired baud rate and parity for the Modbus network from the available choices. To cycle through the choices type

m <Enter>

Each choice appears on the screen, similar to the following:

**P04 PORT 2 PROTOCOL: MODBUS 9600
EVEN**

When the desired choice appears type

e <Enter>

to select a particular option. As this command changes the communications for Port 2, the terminal session ends and communications to the computer is stopped.

Refer to Section 3 – Software for details on the different types of protocols.

If necessary to re-enter the software, the logon process is required.

Operating mode may also be entered using the appropriate Quick Start feature. When this is invoked the terminal session is also terminated.

THIS PAGE INTENTIONALLY LEFT BLANK

SECTION 3

SOFTWARE

Default Settings

When shipped from the factory, the Modbus MicroGateway is configured as shown in Table 2.

Table 2 – Default Settings

	PROTOCOL	COMMUNICATION
PORT 1	YK with SSS using York Talk 3 with F74 disabled	19.2 kbaud and odd parity
PORT 2	Terminal VT100 Interface	9600 baud and no parity
PORT 3	Modbus RTU	19.2 kbaud, no parity, 2 stop bits

These standard settings can be changed in one of two ways:

- Enter a Quick Start address via the Node switch.
- Modify the program using a VT100 terminal emulation program.

Quick Start

The Quick Start feature provides a user with an easy way to configure the Modbus MicroGateway for compatibility with many standard YORK chillers. The feature does not require a VT100 interface and is completely self-contained within the MicroGateway's hardware. No additional tools are required.

A Quick Start feature is selected using the node switch. The user selects one of the reserved addresses between 200 to 255 (although profiles may not be currently allocated for all reserved addresses) and the selected "profile" is loaded.

A profile is a list of configuration parameters that make a particular application unique. The standard profile is stored in EPROM but written to E² once selected by the user.

As an example F74 (Mod York Talk 3) may be configured to communicate with a YK or YT OptiView chiller micro panel. The difference is essentially the type of micro-objects assigned to a given page within the feature. In the case of a YK chiller, micro-objects A, B and C may be stored in E². For a YT chiller micro objects D, E and F may be stored in the same location. The selected profile stays

YORK INTERNATIONAL

in E² until overwritten by a new Quick Start selection or the user manually changing the page contents via a computer.

The Quick Start feature is selected by the setting the node switch to a specific address and following the Power Up/Power Down sequence.

Quick Start Settings Table

The table titled Quick Start Settings, along with the tables in the appendix, summarizes the parameters invoked with each Quick Start feature. Along with the protocol and communication settings, the number of STATUS LED flashes is shown.

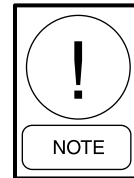

NOTE: The number of STATUS LED flashes is based on a cycle. A cycle consists of the number of flashes, followed by a 3.5 second period of no flashes.

The tables in the Appendix list the micro objects, scaling, Modbus address, etc., for each applicable Quick Start feature.

For Quick Start 255, no changes are made to the Port 1 protocol. The parameters previously selected remain in place.

Power Up/Power Down Sequence

To select a Quick Start feature the following process must be followed:

1. Remove the power harness from **J1** to disconnect power.
2. Note the Modbus network address of the MicroGateway.

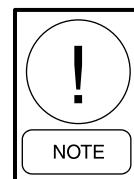

NOTE: Note the OPEN (off) label on the switch versus the ON (closed) label on the board to ensure the correct address is set. Refer to the figure titled Setting the Node Switch.

3. Change the node switch to the desired Quick Start address.

Table 3 – Quick Start Settings

Quick Start (NODE Address)	Port 1				Port 2			No. of STATUS LED Flashes	Appendix Table***
	Protocol	Type	Transfer Rate*	Parity**	Type	Transfer Rate*	Parity*		
Setting	f70p03		f70p06	f70p08	f70p03	f70p07	f70p08		
255	Unchanged	Unchanged	Unchanged	Unchanged	Terminal	9600 baud	None	4	
254†	York Talk 3	YK SSS	19.2 kbaud	Even	Modbus	9600 baud	Even	5	A-1
253†	York Talk 3	YK VSD	19.2 kbaud	Even	Modbus	9600 baud	Even	6	A-2
252†	York Talk 3	YT SSS	19.2 kbaud	Even	Modbus	9600 baud	Even	7	A-3
251†	York Talk 3	YT VSD	19.2 kbaud	Even	Modbus	9600 baud	Even	8	A-4
250†	York Talk 3	YS SSS	19.2 kbaud	Even	Modbus	9600 baud	Even	9	A-5
249††	York Talk 2 Version 6	York Talk 2 w/ Section 1	1200 baud	Even	Modbus	9600 baud	Even	10	A-6
248††	York Talk 2 Version 6	York Talk 2 w/ Sections 1 & 2	1200 baud	Even	Modbus	9600 baud	Even	11	Not Applicable ****
247††	York Talk 2 Version 6	York Talk 2 w/ Section 1	4800 baud	Even	Modbus	9600 baud	Even	12	A-7
246††	York Talk 2 Version 6	York Talk 2 w/ Sections 1 & 2	4800 baud	Even	Modbus	9600 baud	Even	13	A-8
245	Selects Metric Units on the OptiView micro panel.							14	
244	Selects Imperial Units on the OptiView micro panel.							15	
243	Runs a Loop Back Communications Test.							1	
240†††	Sets Pages 32 and 33 to divide by 10.							19	
128	Returns the MicroGateway to EPROM defaults.							3	

* Default selected according to protocol and type. May be edited by user.

** Default selected according to protocol and type. Cannot be overridden by user.

*** References the applicable Table in the Appendix.

**** Currently there are no chillers that use 2 sections at 1200 baud.

† Configures York Talk 3 f74p01 field 1 to ENABLE, field 2 to 800 msec and field 3 to Imperial. Sets f74p02 field 1 to 3.

†† Configures York Talk 2 f73p01 field 1 to 1 and field 2 to 30 sec and f73p02 field 1 to 3.

††† Applies to Port 2 and Port 3, if equipped.

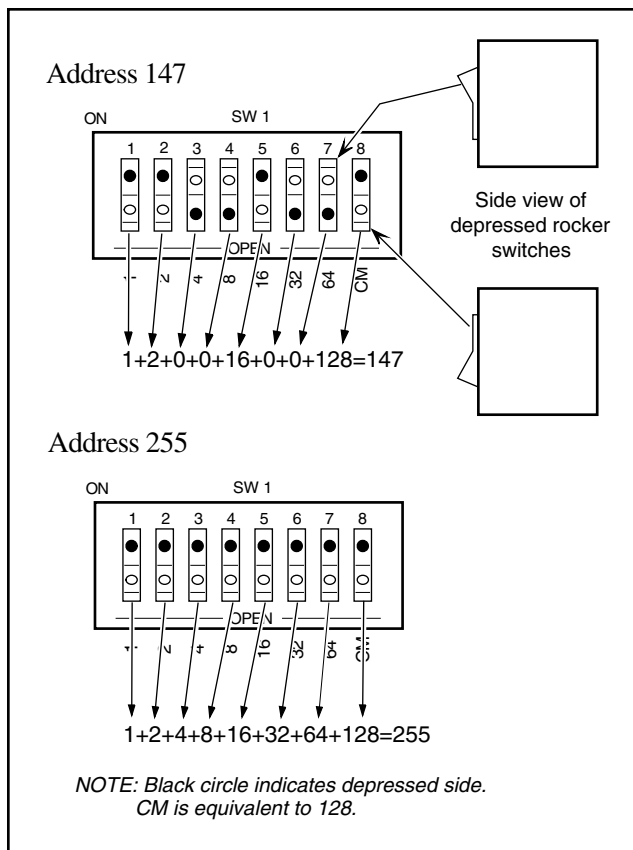
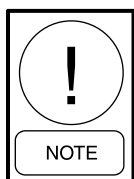

Figure 7. Setting the Node Switch

4. Connect the power harness to **J1** to reconnect power.
5. Observe the STATUS LED to verify that it flashes the correct number of times per cycle for the selected address (refer to the appropriate Quick Start description for the correct number of flashes).
6. Remove the power harness from **J1** to disconnect power.
7. Reset the node switch to the Modbus network address noted in step 2.
8. Connect the power harness to **J1** to reconnect power.

The selected Quick Start feature remains in the E² memory and is written to Modbus Register **412** even though the node switch has been reset to a Modbus network address.



NOTE: Quick Start selections of 243, 244 and 245 are not copied to Modbus Register 412.

For example, if the last Quick Start setting was 250, then 250 will be loaded into Register **412**.

Quick Start 245

When Quick Start 245 is invoked the units are changed to metric. This is only applicable when using York Talk 3 (f74p01). The attribute is sent to the OptiView micro panel when power is first applied or if the MicroGateway is reset. If the micro panel does not provide an acknowledgement of receipt of the request, the Modbus MicroGateway will continue making the request until a satisfactory result is achieved.

During this period the communications with the micro panel are suspended. The STATUS LED flashes 14 times per cycle, indicating that the user has correctly invoked the Metric units selection.

Quick Start 244

When Quick Start 244 is invoked the units are changed to Imperial. This is only applicable when using York Talk 3 (f74p01). The attribute is sent to the OptiView micro panel when power is first applied or if the MicroGateway is reset. If the micro panel does not provide an acknowledgement of receipt of the request, the Modbus MicroGateway continues to make the request until the correct result is achieved.

During this period the communications with the micro panel are suspended. The STATUS LED flashes 15 times per cycle, indicating that the user has correctly invoked the Imperial units selection.

Quick Start 243

Selecting this Quick Start feature begins a “loop-back” communication test between Port 1 and Port 2 of the Modbus MicroGateway. The objective of this test is to verify the functionality of the hardware. Specifically the processor’s two USARTs and associated transceivers.

When this function is invoked, the software sends a test message from Port 1 to Port 2 and expects to receive a predefined acknowledgement. If the expected reply is received, the STATUS LED flashes once per second. If the expected reply is not received the STATUS LED is set to “off.” The test remains active as long as the node switch is set to 243.

To verify operation of both types of transceivers (RS232 and RS485) two different connections must be made.

To start the communications test:

1. Remove the power harness from **J1** to disconnect power.
2. Set the node switch to address 243.
3. To verify proper operation of the RS485 hardware, connect Port 1 (TB1) and Port 2 (TB2) using a 3-core cable as shown in the figure titled Communications Test Connections.
3. Connect the power harness to **J1** to reconnect power. The TX and RX LEDs should flash as communications are attempted.
 - a. If the STATUS LED does not flash once per second after approximately 15 seconds, the communication hardware is faulty. (The problem could be a bad transceiver or a bad USART).
 - b. If the STATUS LED flashes once per second, the communication hardware is functioning correctly.
4. Remove the power harness from **J1** to disconnect power.
5. To verify proper operation of the RS232 hardware, repeat steps 2 through 4 for Port 1 (TB3) and Port 2 (TB4) as shown in the figure titled Communications Test Connections.

Quick Start 128

Selecting Quick Start 128 allows the user to re-configure the MicroGateway for either the original factory defaults or to ensure that the applications of a newly installed EPROM are copied to E².

The STATUS LED flashes 3 times per cycle until all the configuration data is copied to E². When complete, the STATUS LED flashes normally at once per second.

To invoke Quick Start 128:

1. Remove the power harness from **J1** to disconnect power.
2. Corrupt the SRAM by removing the capacitor enable jumper from location **JP7** for a minimum of 10 seconds.
3. Install the jumper at **JP7**.
4. Set the node switch to address 128.
5. Connect the power harness to **J1** to reconnect power.
6. Observe the STATUS LED. While data is transferring, the STATUS LED flashes at a rate of 3 times per cycle. When the data transfer is complete, it flashes at a rate of one flash per cycle.

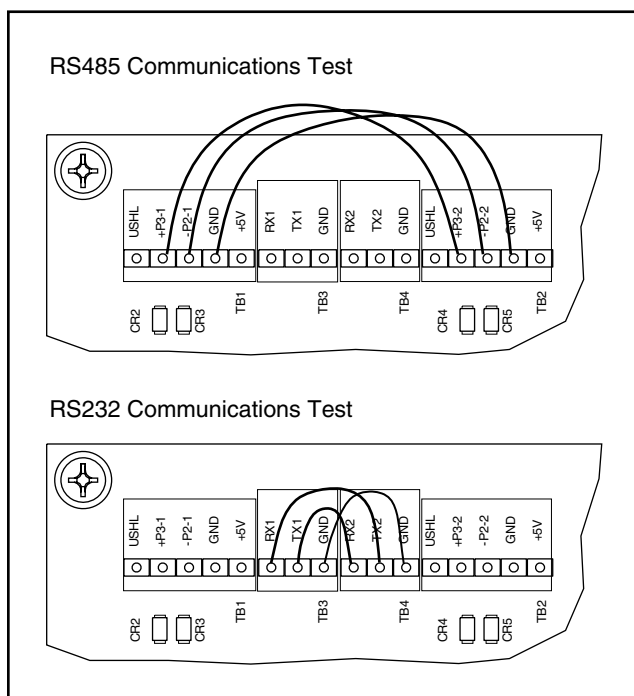
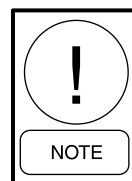

Figure 8. Communications Test Connections



NOTE: Only data that has been changed is transferred. If few changes have been made, the transfer may take less than a second and the 3 flashes per cycle will not be observed.

7. Remove the power harness from **J1** to disconnect power.
8. Setup the required configuration by selecting a Quick Start feature. If terminal emulation is required for configuring the MicroGateway, set the node switch to 255 and follow the Logon Procedure in Section 2.
9. Set the node switch to the desired Modbus network address.
10. Connect the power harness to **J1** to reconnect power.

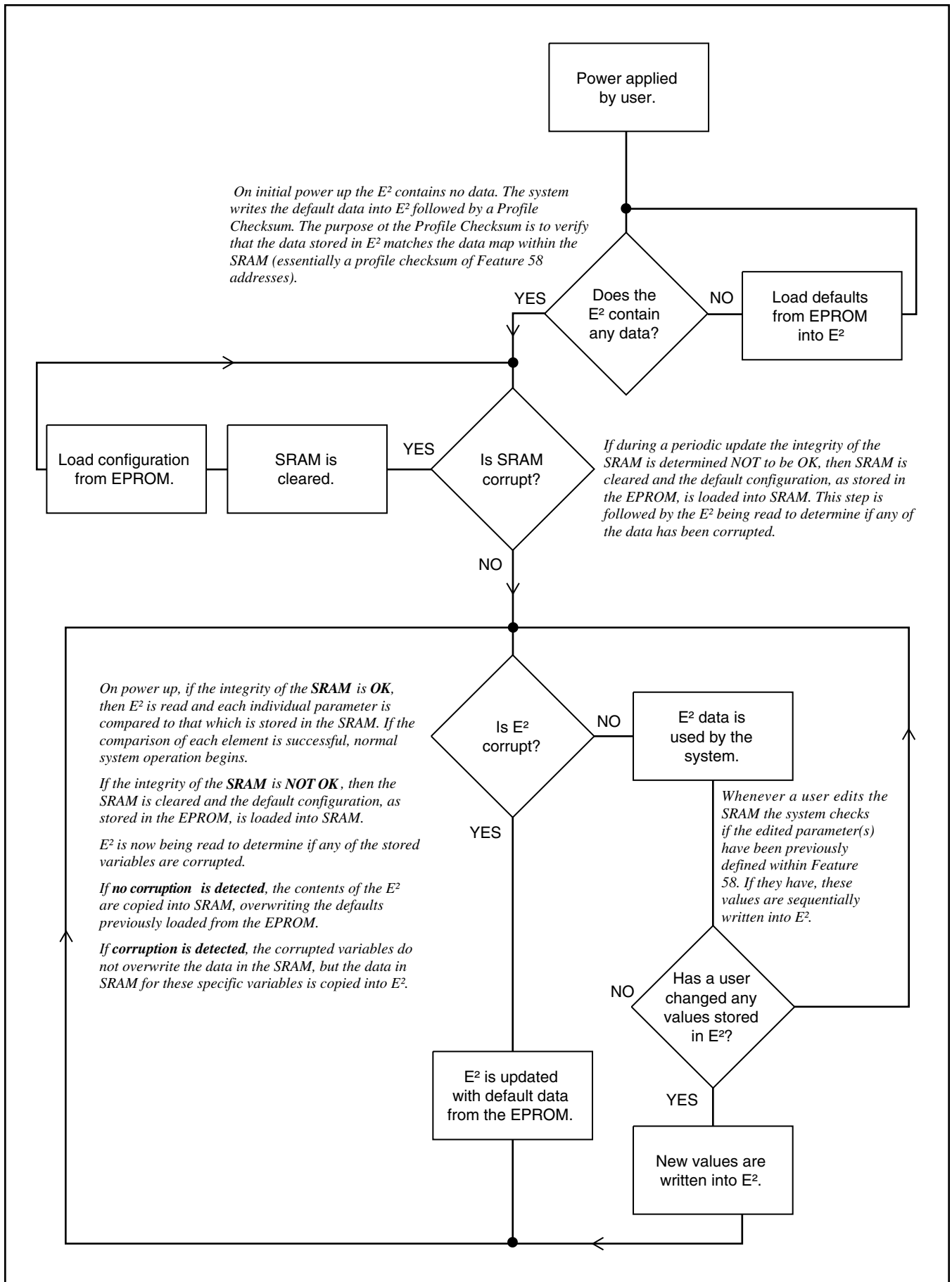

Figure 9. E² Operational Theory

E² Default Settings

When power is first applied the operating system downloads all the features from the EPROM into SRAM. Features are modules of functionality that may be modified by a user. A feature may be modified by a user as desired for a specific application. However, if power is removed from the MicroGateway for more than 72 hours, SRAM loses any stored data and all modifications must be reloaded.

To prevent losing this information in power loss situations, data is backed up into E². If a feature has been modified from the defaults loaded into the EPROM, E² retains a copy of the edited information. The data stored in E² enables a previously modified feature to be recalled after a prolonged (greater than 72 hour) power outage.

When power is applied to the MicroGateway after data loss, the system reloads the features from the EPROM into SRAM.

The following lists the fields and the default values (shown in bold) stored in E². These values are only stored in E² after the appropriate Quick Start is invoked. If a Quick Start is not used, this data must be manually entered and is then stored in E² as the new default.

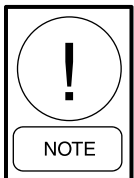

NOTE: *If a Quick Start is later invoked, E² is overwritten with the Quick Start defaults.*

Feature 70 Port Setup

P03 PORT 1 PROTOCOL: **YORK TALK 3**
 P04 PORT 2 PROTOCOL: **TERMINAL**
 P06 PORT 1 BAUD RATE: **19K2**
 P07 PORT 2 BAUD RATE: **9600**
 P09 YT3 POLL DELAY TIMER **1000 MSEC**

Feature 72 York Talk 1

P01 CHILLER ID **1** POLL TIME **30**
 P02 RETRIES **3**

Feature 73 Section 1 York Talk 2

P01 CHILLER ID **1** POLL TIME **30**
 P02 RETRIES **3**

Feature 73 Section 2 York Talk 2

P01 CHILLER ID **0** POLL TIME **30**
 P02 RETRIES **3**

Feature 74 Section 1 York Talk 3

P01 MODE **ENABLED** TIME OUT **800 MSEC IM**
 P02 RETRIES=**3**
 P86 GET YM TIME & DATE **0 s**

Feature 74 Section 2 York Talk 3

P01 MODE **DISABLED** TIME OUT **800 MSEC IM**
 P02 RETRIES=**3**
 P86 GET YM TIME & DATE **0 s**

For additional data stored in E² refer to the appendix.

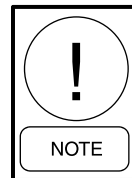

NOTE: *Sections 3 and 4 in Feature 74 do not store any information in E² as defaults.*

Feature 75 Section 1 Modbus Range

P01	OUTPUT HI VALUE :	2
P02	OUTPUT LO VALUE:	1
P03	SENSOR HI VALUE:	2
P04	SENSOR LO VALUE:	1
P05	NUMBER RANGE	UNSIGNED

Feature 75 Section 2 Modbus Range

P01	OUTPUT HI VALUE :	5
P02	OUTPUT LO VALUE:	1
P03	SENSOR HI VALUE:	3
P04	SENSOR LO VALUE:	1
P05	NUMBER RANGE	UNSIGNED

The appendix lists the scale fields, range fields and micro-objects (where applicable) which are loaded when a Quick Start Feature is invoked. The tables also show which items are stored in E² as defaults.

Customizing the EPROM

If an application is customized and needs to be made permanent, an application-specific EPROM may be created. This ensures that, if a power loss occurs for more than 72 hours, all the entered application is reloaded into the SRAM.

To create an EPROM several items are required.

1. The application must be complete.
2. An EPROM programmer must be available. This “burns” the program into the EPROM.

3. A conversion utility must be used to convert configuration file into a hex file. YORK HEX is an MS-DOS program available from the YORK BAS Group.



CAUTION: YORK HEX requires a knowledge of MS-DOS and its file naming and directory structure. If not familiar with MS-DOS, do not attempt to create EPROMs.

To “burn” an EPROM:

1. Connect the MicroGateway to a PC (refer to Section 2 for details).
2. Logon to the MicroGateway in Configuration Mode (refer to Section 2 for details). Utilizing the MicroGateway Configurator (ISNTTools) establish communications with the Modbus MicroGateway.
3. Complete the procedure for editing data to create an application (see Section 2 for details). The edited application is now stored in the MicroGateway’s SRAM.
4. Exit the MicroGateway Configurator window. Do not exit the program.
5. Right click on the MicroGateway Configurator icon and select **Run Save/Restore**.
6. In the dialog box enter the network number (set to **0**) and node address number for the MicroGateway and select **Save**.
7. In the file name combo box type the name for the new file. Be sure to locate the file in a directory which can be accessed by YORK HEX. The file name is limited to 8 characters, followed by the file name extension **.cnf** with no spaces.

Example (mdcapp.cnf)

8. The save configuration box appears. Verify that the data is correct and select **OK** to save the file.
9. When the save is complete close the MicroGateway Configurator.
10. Select **Start** and **Run** to bring up the Run dialog window. In the box type

```
yorkhex c:\xxx\mdcapp.cnf mdcapp.hex
<Return>
```

where xxx is the directory where the cnf file was stored. This opens the YORK HEX program, loads the configuration file and names the new, hex file.

The following appears on the screen

```
YORK CONTROLS BRAM FILE TO INTEL
HEX FORMAT CONVERSION UTILITY -
YORKHEX V3.00
```

Configuration to convert:

Unit identification: MODBUS 0000

**Software Product No. :ISN M B01 R88 T01
02-Mar-2001**

Number of bytes to transfer = xxxx

Base segment address = F100

Xxxxxx Bytes converted

Conversion complete : No Errors

CONVERSION FINISHED

11. Close the MS-DOS window.
12. Clear the buffers on the EPROM programmer before loading the file.
13. Select the device type (272001) and programming speed (80 ns) of the EPROM to be programmed.
14. Set the offset to **C0000H**.

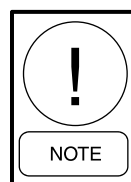

NOTE: This assumes a Stag or similar type of EPROM Programmer. Refer to the programmer documentation for proper settings for other types of programmers.

15. Load the base firmware into the programmer’s buffer.
16. Overlay the application firmware in the programmer buffer. Record the **Check Sum** for the base and application firmware.
17. Place the EPROM in the socket of the programmer and select program.
18. When the program is finished remove the EPROM. Place a label on the EPROM which must include the firmware version, check sum and date.

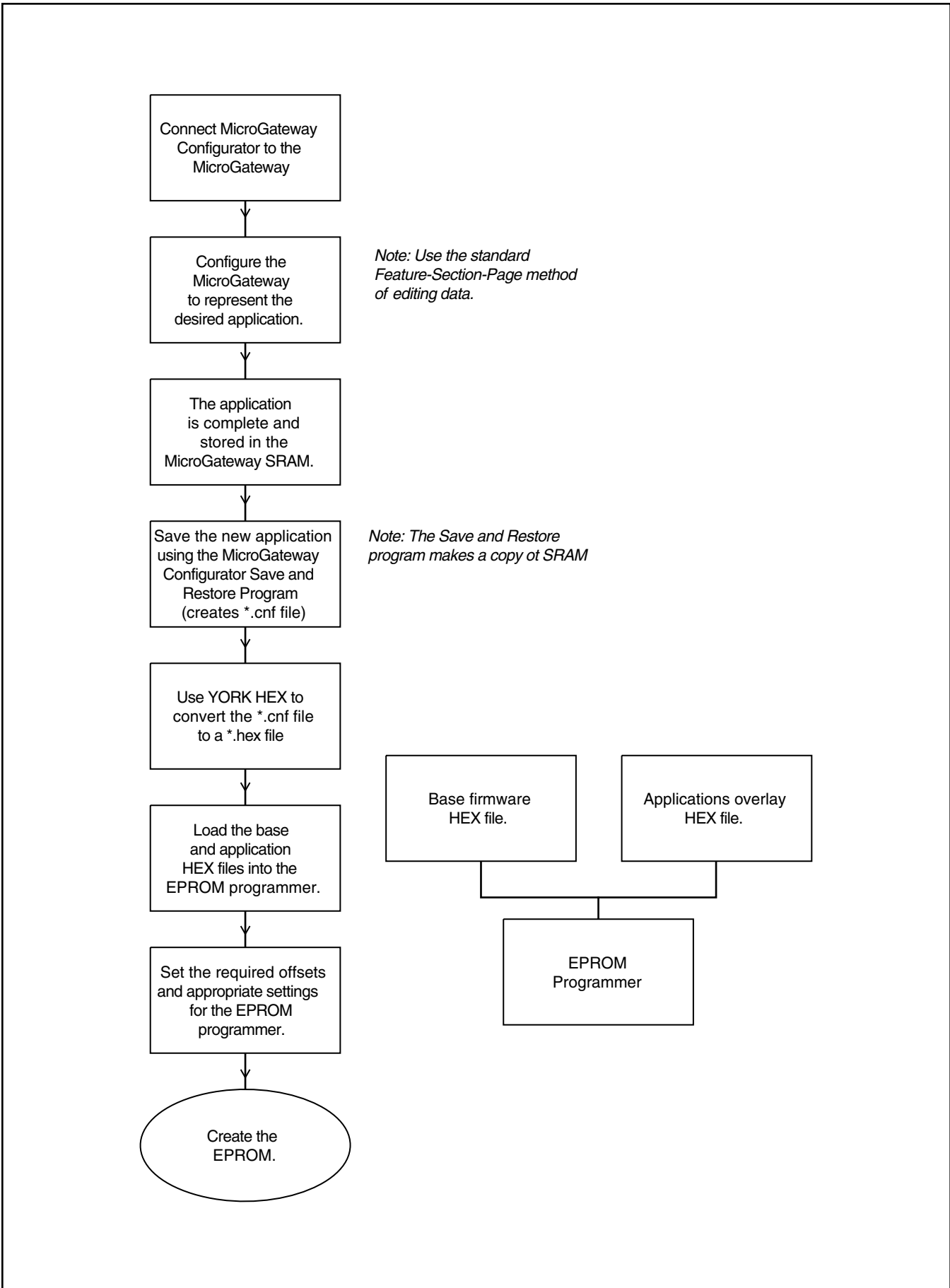

Figure 10. EPROM Creation

Feature Set

To customize the Modbus MicroGateway beyond the applications provided by the Quick Start features, YORK's "Feature-Section-Page" methodology is used. The features and number of sections available in the Modbus MicroGateway is summarized in Table 4.

The Modbus MicroGateway's software is organized into discreet functional modules called features. Each feature is a self-contained set of routines that are designed to perform a specific task or set of tasks. For example, F74 (Mod York Talk 3) is used to exchange data between the Modbus MicroGateway and the OptiView micro panel. F70 (Port Setup) is used to assign different protocols to the MicroGateway's ports.

Some features are made extensible through the use of sections. Each section is another set of the same functions. For example, F73 (Mod York Talk 2) has two sections. Section 1 is used to connect chillers that only have enough data to populate one section. Section 2 is an identical functional copy of Section 1 used by applications that require greater data capacity.

Every feature is further subdivided into pages. A page represents a finite attribute or set of attributes for a specific aspect of the features function. For example, page 4 of F70 (Port Setup) displays the type of York Talk protocol configured on Port 2.

Table 4 – Feature List

Feature Number	Description	Number of Sections
01-57	Unavailable	–
58	E ² Setup	20
59	E ² Data	20
60-69	Unavailable	–
70	Port Setup	1
71	Statistics Setup	1
72	Mod York Talk 1	1
73	Mod York Talk 2	2
74	Mod York Talk 3	4
75	Modbus Range	50

To build a unique application a user edits the required features, sections and pages. The edited features collectively represent the application for a specific need. (This is sometimes referred to as the Application Overlay.)

To build and modify the application use a VT100 terminal emulation program, such as the MicroGateway Configurator (ISNtools). The language syntax used is expressed as

fnn – Represents a feature, such as f70, where *nn* represents a number.

snn – Represents a section, such as s01, where *nn* represents a number.

pnn – Represents a page, such as p04, where *nn* represents a number.

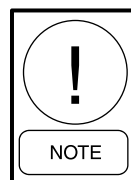

NOTE: Always use lower case when typing commands into the MicroGateway Configurator (ISNtools). Use upper case when typing labels into text fields.

To edit a field within a page, "open" the page for editing by typing

e <Return>

To proceed to each subsequent field type

e <Return>

If a field requires a number variable to be entered, it is indicated by *vvv*. A text field is indicated by *tt...t* and a menu selections is indicated by *mm...m*.

To toggle through the menu items type

m <Return>

Once the desired item is shown on the screen, confirm the choice by typing

e <Return>

to select it.

A help screen can be accessed by typing **help** <Return> at the prompt after logging on to the MicroGateway.

Example

The following example shows how to view and edit the communications settings on Port 1.

1. Connect to the MicroGateway and logon. Refer to the instructions in Section 2 for details.

2. Type

f70p03 <Return>

Screen response

P03 PORT 1 PROTOCOL: YORK TALK 3

The unit enters Feature 70, Page 3 and responds with the current setting.

3. To change the setting, type

e <Return>

Screen response

mmmmmmmm

The field is “opened” for editing. When *mm...m* is displayed it indicates the field has a menu list of choices.

For other fields *vv...v* may be displayed, which indicate a value must be entered. When *tt...t* is displayed, text may be typed into the field.

4. To cycle through the menu type

m <Return>

Screen response:

P03 PORT 1 PROTOCOL: YORK TALK 2 V4
1200

which is the next choice on the menu. Continue cycling through the list until the desired choice appears on the screen. When the desired choice appears close the edit by typing

e <Return>

Screen response:

P03 PORT 1 PROTOCOL: YORK TALK 2 V4
4800

For pages with multiple fields, each subsequent *e* <Return> selects the next field.

The following describes the features, attributes and functionality in detail.

F58 – E² (EEPROM) Setup

P01 Fv Sv Pw Dv OKAY

Feature 58 allows a user to specify the address of any user-editable data located in the SRAM which is required to be stored in E². This data is then maintained during a power failure in the event of the SRAM being corrupted.

If a system de-configures, the data stored in the E² is reloaded into SRAM, ensuring the application's program is not affected. A system reset does not have any effect on the operation of the E².

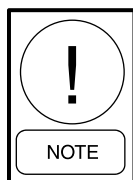

NOTE: On-line changes made to F58 are stored in SRAM only. For permanent changes, a new EPROM must be burned.

The E² Setup Feature is an engineering Feature consisting of 20 Sections each with 60 Pages per section.

Fvv (Feature Number) – This is the address of the Feature where the variable is located.

Svv (Section Number) – This is the address of the Section number where the variable is located.

Pvv (Page Number) – This is the address of the Page number where the variable is located.

Dvv (Data Field) – This is the field number on the Page whose data is to be saved. This must be greater than 0.

Status Information – The Status Information is generated by the system and indicates the condition of the data in E².

OKAY indicates the Field Data defined will fit into E².

OVERFLOW indicates the Field Data defined will not fit into the E².

CALCULATING will appear while the system is calculating the number of bytes required. When finished, either OKAY or OVERFLOW will appear.

F59 – E² (EEPROM) Data

P01 Fv Sv Pw Dv OKAY

Feature 59 is used to display the Feature, Section, Page and Field references which point to the data stored in E². The structure is identical to F58, with 20 Sections and 60 Pages per section.

F70 – Port Setup

F70 PORT SETUP

Feature 70 (F70) allows the user to configure the ports for the various protocols and communication metrics. The user may also configure the keyboard timeout and view port status.

P01 KEYBOARD TIMEOUT 5 MINUTES

The MicroGateway reverts to an advisory mode if the computer attached is inactive for a the amount of time specified on this page. P01 allows the user to change the time allotted before the keyboard time outs. To return to the edit mode from the advisory mode, the password must be entered.

The default keyboard timeout is set to **5** minutes.

P02 STATUS: PORT 1 BUSY PORT 2 BUSY

Page 2 displays the status of the two communication ports. The status can be either **BUSY** or **FREE**. If a port is transmitting or receiving data, the status is **BUSY**. All other times, **FREE** is displayed.

Page 2 is system-generated and not editable by a user.

P03 PORT 1 PROTOCOL: YORK TALK 3

Page 3 allows the user to select the protocol used on Port 1. The available choices are shown in Table 5.

When a new protocol is selected:

1. The default baud rate and parity for the new selection is automatically set on P06 and P08.
2. The watchdog update function is suspended, allowing the hardware timer to timeout (requires approximately 1.6 seconds) and causes the system to be reset.

Table 5 – Port 1 Protocols

PORT 1 PROTOCOLS
York Talk 2 V4 1200
York Talk 2 V4 4800
York Talk 2 V6 1200
York Talk 2 V6 4800
York Talk 1
York Talk 3

Because the system is reset the user must again perform a login to establish communications between the terminal and MicroGateway. It is not necessary to reset the node switch to 255.

P04 PORT 2 PROTOCOL: TERMINAL

Page 4 allows the user to select the protocol for Port 2. The available choices are shown in Table 6.

When a new protocol is selected:

1. The default baud rate and parity for the new selection is automatically set on P07 and P08.
2. The watchdog update function is suspended, allowing the hardware timer to timeout (requires approximately 1.6 seconds) and causes the system to be reset.

Table 6 – Port 2 Protocols

PORT 2 PROTOCOLS
Terminal
Modbus RTU 9600 baud Odd
Modbus RTU 19200 baud Odd
Modbus RTU 9600 baud Even
Modbus RTU 19200 baud Even
Modbus RTU 9600 baud Ignore
Modbus RTU 19200 baud Ignore
Modbus RTU 9600 baud None
Modbus RTU 19200 baud None

If the node switch is set to 255 (terminal communications) the protocol for Port 2 will revert back to terminal communications on the next cycle.

Once the terminal protocol for Port 2 is no longer selected, user communications between the terminal and MicroGateway are stopped. The MicroGateway is no longer in edit mode. To make further changes, the logon sequence must be repeated. Refer to the “Section 2 – Communications.”

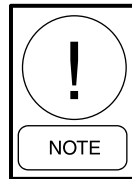

NOTE: *If the node switch is set to address 255, the MicroGateway will remain in Configuration Mode. Change the node switch to select a Modbus address between 1 and 200 before changing Page 4 from terminal mode.*

P05 NODE NO: 99 ACTUAL 127

Page 5 displays node information. The first field, Node No., reflects the setting of the node switch but is truncated when a number greater than 99 is selected.

The second field displays the actual address of the node switch.

P06 PORT 1 BAUD RATE: 1200

P07 PORT 2 BAUD RATE: 9600

Pages 6 and 7 set the data transfer rate for Port 1 and Port 2, respectively. A default baud rate is automatically set when the protocol selection is made.

Not all protocol options support all baud rates. If an unsupported baud rate is chosen, the previous selection is retained.

P08 PARITY PORT 1: ODD PORT 2: NONE

Page 8 displays the parity for Port 1 and Port 2. The parity for Port 1 is set automatically according to the York Talk protocol selected in P03. The parity for Port 2 can be chosen but is only active when in Configuration Mode (using the terminal). Once a Port 2 protocol is selected, the parity is determined by the settings in P04.

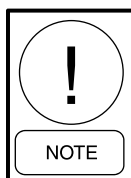

NOTE: *When the node switch is set for 255, the parity is always NONE. To change the parity, the node switch must be set to the Modbus network address.*

P09 YT3 POLL DELAY TIMER 1000MSEC

Page 9 is only valid when using York Talk 3 protocol. This parameter sets the idle time for the York Talk 3 task. During this time no communication requests are sent. This time delay lessens the communications load received by the OptiView micro panel.

Enter a variable in the field to set the polling rate in milliseconds.

F71 – Statistics Setup

F71 STATISTICS SETUP

Feature 71 (F71) provides information on the operation and integrity of the MicroGateway. The passwords may be edited but no other fields are user-editable.

P01 MODBUS 0000 SAT 01-JAN-2000 00:01

Page 1 displays the unit name, ID number, date and time the software was created. The unit name is MODBUS.

P02 SOFTWARE PRODUCT: ISN MDC 88 *nn*

Page 2 displays the code and firmware descriptor. For the Modbus MicroGateway, the product number is ISN MDC 88*nn* where *nn* is the revision level.

P03 RELEASE TYPE: FULL

Page 3 indicates the type of release for the software. The release type indicates whether the software is a beta version or full release.

P04 TEMPLATE NAME:

Page 4 displays the template name. Templates are used by the York Engineering Software (YES) to create unique applications for ISN software. It is included with this software but not valid for the Modbus MicroGateway. Therefore, this field will always be blank.

P05 MEMORY MAP VERSION: 01

Page 5 is the memory map version, which relates to the design level. This is an internal design reference.

P06 RELEASE DATE: 06-FEB-2001

Page 6 shows the release date of the software for troubleshooting and tracking purposes.

P07 HARDWARE TYPE: UG REVISION: 01

Page 7 indicates that the hardware type is the MicroGateway. Revision indicates the design level of the hardware.

3

P08 CURRENT SYSTEM LOAD: 9.6%

Page 8 provides an indication of the amount of time (as a percentage) the processor is spending to process data within a system cycle. If the number rises above 75%, various tasks within the system will be intermittently suspended.

P09 PEAK SYSTEM LOAD: 9.6%

Page 9 provides an indication of the maximum peak load used by the system since the last reset of the MicroGateway.

P10 BRAM CHECKWORD 8285

Page 10 displays the checksum value of all the configured data in SRAM. This is used by the software during power up and normal operation to determine the integrity of the memory modules.

P11 RECONFIGURE SYSTEM

Reconfigures the system to the default settings. E² is not replaced or overwritten, retaining application data. To reconfigure the system the user enters the field and enters the current password.

P12 RESET SYSTEM

Resets the system, starting the software cycle over. To reset the system the user enters the field and enters the current password.

P13 MEMORY UTILISATION: 43%

Page 13 provides an indication of the percentage of the memory currently being used by the application.

P14 CHILLER TYPE: VOID

This is the type of chiller that is attached to Port 1 if Quick Start has been utilized. If a Quick Start is not loaded, this field displays VOID. It is a non-editable field. The available choices are shown in Table 7.

Table 7 – Chiller Types

CHILLER TYPE OPTIONS
Void
YK with SSS
YK with VSD
YT with SSS
YT with VSD
YS with SSS
York Talk 2 1200 Section 1
York Talk 2 1200 Section 1 & 2
York Talk 2 4800 Section 1
York Talk 2 4800 Section 1 & 2

P15 PASSWORD5 5555 FEATURE EXTENT 75

This shows the current active password. The password consists of up to eight alpha-numeric characters.

The Feature Extent lists the number of features which are editable using the listed password. As an example, if the Feature Extent listed is 72, features from 0 to 72 may be edited using that particular password. Features above 72 are not editable.

F72 – Mod York Talk 1 & F73 – Mod York Talk 2

General

The Modbus MicroGateway firmware contains three different types of York Talk protocols; F72 (Mod York Talk 1), F73 (Mod York Talk 2) and F74 (Mod York Talk 3). Only one of these York Talks can be configured to communicate with a micro panel at any one time. All of these features are organized into data blocks that may be characterized in the following way; **Input**, or **Output**, **Analog** or **Digital**.

Every section within any of the York Talk features is an exact duplicate of the structure shown in Table 8.

Table 8 – York Talk Point Types

York Talk Page No:	Type of Point	Direction of Data Flow
3 to 6	Analog	Inputs to the Chiller
6 to 10	Binary	Inputs to the Chiller
11 to 35	Analog	Outputs from the Chiller
36 to 55	Binary	Outputs from the Chiller
56 to 65	Analog (Codes)	Outputs from the Chiller
66 to 79	Analog	Outputs from the Chiller
80 to 84	Binary	Outputs from the Chiller

Feature 72 and Feature 73 share the same data structure and type of user interface. While the protocol used to pass data between the MicroGateway and the micro panel is different, the configuration parameters offered to the user are identical in both cases.

The description of the attributes of each of the pages that follows is valid for both F72 and F73 and are therefore not listed separately. The F74 descriptions are different and listed in the next section.

F72 MOD YORK TALK 1

F73 MOD YORK TALK 2

Only the one protocol is usable at a time. If York Talk 1 has been selected in Feature 70 Page 3, use F72. If York Talk 2 has been selected in Feature 70 page 3, use F73.

The points lists for some specific OptiView chillers are listed in the Appendix of this manual. In addition, a list of all other chillers is available at

www.intranet.york.com/web0147/

P01 CHILLER ID 1 POLL TIME 30

Page 1 allows the user to set the chiller ID. Normally this is set to 1. This must match the ID set on the chiller micro panel's the rotary switch. The chiller ID is determined by adding 1 to the address set on the micro panel's rotary switch.

The poll time is the amount of time allocated for the MicroGateway to poll and then to receive a response back from the micro panel. This may be modified to reflect the expected network traffic. The default poll time is 30 seconds.

P02 RETRIES 3 COMMS GOOD

Page 2 sets the number of times the MicroGateway will request information from the micro panel before determining that communications are faulty. The second field in page 2 is system generated and indicates the status of the communications.

3

P03-P06 Analog Outputs to the Chiller

P03 AO nnnn S 1 R 0 VVVV vvvv

Pages 3 to 6 configure analog output points to control the chiller from the Modbus network. These are specific to the chiller per the applicable spreadsheet.

AO – Indicates that the point requires an analog value to be sent from the Modbus client. This value is sent to the micro panel to perform a specific function, e.g. set the leaving chilled liquid set point. This is a system generated point descriptor.

nnnn – Indicates the pre-configured Modbus address. This address may be edited by the user but it is not stored in E². If the SRAM is corrupted in any way, this value is reset to the default value stored in the EPROM.

S 1 – Indicates the scaling applied to the value received from the Modbus client before it is sent to the micro panel. Scaling can be set to either **0**, **1**, **2**, or **3**. Typically a **1** is set in this field, resulting in the value sent to the micro panel being divided by 10. Refer to the section on scaling.

R 0 – Indicates if the data is processed using the Range feature. **0** indicates no processing. Any number other than **0** represents the section of F75 which is used to process the data. Refer to the section on range.

VVVV – Indicates the current value received by the MicroGateway. This is system generated.

vvvv – Allows a user to select a default value which is stored in E². This value is the initial value sent to the micro panel before the Modbus client has an opportunity to update the value.

P07-P10 Digital Outputs to the Chiller

P07 BO nnnn MMMM mmmm

Pages 7 to 10 configure digital output points to control the chiller from the Modbus network. These are specific to the chiller per the applicable spreadsheet.

BO – Indicates that the point requires a digital value to be sent from the Modbus client. This value is sent to the micro panel to perform a specific function, e.g. start or stop the chiller. This is a system generated point descriptor.

nnnn – Indicates the pre-configured Modbus address. This address may be edited by the user. For York Talk 2, Section 1, Pages 7, 8 and 9, it is stored in E². All other points are not stored in E². When not stored in E² and the SRAM is corrupted in any way, this value is reset to the default value stored in the EPROM.

MMMM – Indicates the current status received by the MicroGateway. It is either **OPEN** or **MADE**. This is system generated.

mmmm – Allows the user to select the default state stored in E². This state is the initial state sent to the micro panel before the Modbus client has had an opportunity to update the state.

P11-P35/P66-P79 Analog Inputs from the Chiller

P11 AI nnnn S 1 R 0 VVVV

Pages 11 to 35 and 66 to 79 configure the analog input points that make chiller data available to the Modbus network. These points correspond to a specific Modbus register. See the Appendix for the standard point listings for a specific chiller.

AI – Indicates that the point represents an analog value sent from the micro panel. This value is made available to the Modbus network, e.g. evaporator pressure. This is a system generated point descriptor.

nnnn – Indicates the pre-configured Modbus address. This address may be edited by the user but it is not stored in E². If the SRAM is corrupted in any way, this address is reset to the default address stored in the EPROM.

S 1 – Indicates the scaling applied to the value before being made available to the Modbus client. Scaling can be set to either **0**, **1**, **2**, or **3**. Typically a **1** is set in this field, resulting in the value from the micro panel being multiplied by 10. Refer to the section on scaling.

R 0 – Indicates if the data is processed using the Range feature. **0** indicates no processing. Any number other than **0** represents the section of F75 which is used to process the data. Refer to the section on range.

VVVV – Indicates the current value received from the micro panel. This is system generated.

P36-P55/P80-P84 Digital Inputs from the Chiller

P36 BI nnnn MMMM

Pages 36 to 55 and 80 to 84 configure digital input points from the chiller to the Modbus network specific to the chiller per the applicable spreadsheet.

BI – Indicates that the point represents a digital status sent from the micro panel. This status is made available to the Modbus client, e.g. liquid line solenoid status. This is a system generated point descriptor.

nnnn – Indicates the pre-configured Modbus address. This address may be edited by the user but it is not stored in E². If the SRAM is corrupted in any way, this address is reset to the default address stored in the EPROM.

MMMM – Indicates the current status received from the micro panel. It is either **OPEN** or **MADE**. This is system generated.

P56-P65 Coded Inputs from the Chiller

P56 AI nnnn S 2 R 0 VVVV

Pages 56 to 65 configure chiller codes to specific points on the network.

AI – Indicates that the point represents an analog value sent from the micro panel. This value is made available to the Modbus network, e.g. Unit Warning Fault Code. This is a system generated point descriptor.

nnnn – Indicates the pre-configured Modbus address. This address may be edited by the user but it is not stored in E². If the SRAM is corrupted in any way, this address is reset to the default address stored in the EPROM.

S 2 – Indicates the scaling applied to the value before being made available to the Modbus client. Scaling can be set to either **0**, **1**, **2**, or **3**. Typically a **2** is set in this field, resulting in the value from the micro panel being passed directly to the Modbus client without modification. Refer to the section on scaling.

R 0 – Indicates if the data is processed using the Range feature. **0** indicates no processing. Any number other than **0** represents the section of F75 which is used to process the data. Refer to the section on range.

VVVV – Indicates the current value received from the micro panel. This is system generated.

P93 RETRY COUNT nnnn

Page 93 tracks the number of communication errors that have occurred since the system was last reset. This counts the number of times the micro panel did not respond on the first communications attempt. An unusually high number may indicate faulty wiring or other network interference.

P94 PRESS ENTER TO RESET YT n TABLE

Page 94 resets the retry counter to 0 and is used in conjunction with page 93 for troubleshooting.

P95 to P97 Not Used

P98 DATA OVERFLOW FLAG SET TO YES

P98 indicates that at least one Modbus register has exceeded the maximum “data container” size. This is system generated.

P99 YORK TALK COMMS 0

P99 indicates the condition of the York Talk communication’s flag. **0** indicates bad communications. **1** indicates good communications.

F74 – Mod York Talk 3

F74 MOD YORK TALK 3

Features 74 (F74) uses the same memory organization as Feature 72 and Feature 73 but includes the extra capability of York Talk 3. York Talk 3 uses a full duplex communications arrangement to allow a fast interface with the micro panel.

Data, organized as objects, may be individually addressed and read or written to. These objects are referred to as micro-objects. Different micro-objects represent different aspects of the chiller's functionality. For example, **AI.1** represents Leaving Chilled Liquid Temperature. The micro-objects for the different OptiView chiller types are loaded using the Quick Starts as listed in the Appendix.

York Talk 3 provides four sections. Of the four, sections 1 and 2 are stored in E². Sections 3 and 4 are currently not used and do not have any fields stored in E².

The micro-objects for the chillers which are loaded using Quick Start are listed in the Appendix of this manual. A list for all chillers is available at

www.intranet.york.com/web0147/

P01 MODE ENABLED TIME OUT 800MSEC IM

Page 1, field 1 allows the complete feature to be enabled or disabled. Although this field is also shown in the other sections, Feature 74, Section 1 governs the operation of all sections.

Field 2 allows the communication timeout to be configured. This field allows a user to set the amount of time between transmitting data.

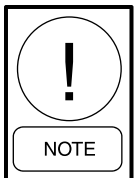

NOTE: The default time out is 800 msec and should not be set to any value less than 800 msec.

Field 3 defines the engineering units. All data returned from the micro panel will be expressed in the selected measurement system. Available options are **IM** (Imperial) or **SI** (Metric). The default is **IM**.

P02 RETRIES=3 COMMS GOOD

Page 2 field 1 defines the number of times the MicroGateway will send a message to a micro-object in an OptiView micro panel which is not responding. After the given number of attempts, a status flag in field 2 changes from **GOOD** to **BAD**.

P03-P06 Analog Outputs to the Chiller

P03 MO uu AO nnnn S 1 R 0 VVVV vvvv PT C

Pages 3 to 6 configure analog output points to control the chiller from the Modbus network. These are specific to the chiller per the applicable spreadsheet.

MO – Indicates the type of micro-object that represents the data in the micro panel.

uu – Indicates the particular instance of the defined micro-object.

AO – Indicates that the point requires an analog value to be sent from the Modbus client. This value is sent to the micro panel to perform a specific function, e.g. set the leaving chilled liquid set point. This is a system generated point descriptor.

nnnn – Indicates the pre-configured Modbus address. This address may be edited by the user but it is not stored in E². If the SRAM is corrupted in any way, this value is reset to the default value stored in the EPROM.

S 1 – Indicates the scaling applied to the value received from the Modbus client before it is sent to the micro panel. Scaling can be set to either **0**, **1**, **2**, or **3**. Typically a **1** is set in this field, resulting in the value sent to the micro panel being divided by 10. Refer to the section on scaling.

R 0 – Indicates if the data is processed using the Range feature. **0** indicates no processing. Any number other than **0** represents the section of F75 which is used to process the data. Refer to the section on range.

VVVV – Indicates the current value received by the MicroGateway. This is system generated.

vvvvv – Allows the user to select the default value stored in E². This value is the initial value sent to the micro panel before the Modbus client has had an opportunity to update the value.

PT – Sets the amount of time between read or write requests from the MicroGateway on a per page basis. Refer to Table 9 for the available choices.

Table 9 – York Talk 3 Poll Rates

MENU	POLL RATE
0s	No Poll Initiated
1s	1 second
2s	2 second
5s	5 second
1m	1 minute
2m	2 minutes
5m	5 minutes
1h	1 hour
2h	2 hours

C – Indicates the status of the communications on a per page basis. Refer to Table 10 for the available choices.

Table 10 – York Talk 3 Status Codes

DISPLAY	DEFINITION
W	Waiting for a value from micro panel
S	Value successfully received
F	Fatal internal error
E	Communication error (message lost)
T	Unknown object type
O	Unknown object (could be wrong object instance number)
P	Unknown property
I	Unknown index
M	Micro panel in local mode
D	Illegal data type
H	Set point too high
L	Set point too low

P07-P10 Digital Outputs to the Chiller

P07 MO uu BO nnnn MMMM mmmm PT C

Pages 7 to 10 configure digital output points to control the chiller from the Modbus network. These are specific to the chiller per the applicable spreadsheet.

MO – Indicates the type of micro-object that represents the data in the micro panel.

uu – Indicates the particular instance of the defined micro-object.

BO – Indicates that the point requires a digital status to be sent from the Modbus client. This status is sent to the micro panel to perform a specific function, e.g. start or stop the chiller. This is a system generated point descriptor.

nnnn – Indicates the pre-configured Modbus address. This address may be edited by the user but it is not stored in E². If the SRAM is corrupted in any way, this value is reset to the default value stored in the EPROM.

MMMM – Indicates the current status received by the MicroGateway. It is either **OPEN** or **MADE**. This is system generated.

mmmm – Allows the user to select the default state stored in E². This state is the initial state sent to the micro panel before the Modbus client has had an opportunity to update the state.

PT – Sets the amount of time between read or write requests from the MicroGateway on a per page basis. Refer to Table 9 for the available choices.

C – Indicates the status of the communications on a per page basis. Refer to Table 10 for the available choices.

P11-P35/P66-P79 Analog Inputs from the Chiller

P11 MO uu AI nnnn S 1 R 0 VVVV PT C

Pages 11 to 35 and 66 to 79 configure analog input points from the chiller to the Modbus network per the applicable spreadsheet. These points correspond to a specific Modbus register. See the Appendix for the standard point listings for a specific chiller.

MO – Indicates the type of micro-object that represents the data in the micro panel.

uu – Indicates the particular instance of the defined micro-object.

AI – Indicates that the point represents an analog value sent from the micro panel. This value is available to the Modbus client, e.g. Evaporator Pressure. This is a system generated point descriptor.

nnnn – Indicates the pre-configured Modbus address. This address may be edited by the user but it is not stored in E². If the SRAM is corrupted in any way, this value is reset to the default value stored in the EPROM.

S 1 – Indicates the scaling applied to the value before being made available to the Modbus client. Scaling can be set to either **0**, **1**, **2**, or **3**. Typically a **1** is set in this field, resulting in the value from the micro panel being multiplied by 10. Refer to the section on scaling.

R 0 – Indicates if the data is processed using the Range feature. **0** indicates no processing. Any number other than **0** represents the section of F75 which is used to process the data. Refer to the section on range.

VVVV – Indicates the current value received from the micro panel. This is system generated.

PT – Sets the amount of time between read or write requests from the MicroGateway on a per page basis. Refer to Table 9 for the available choices.

C – Indicates the status of the communications on a per page basis. Refer to Table 10 for the available choices.

P36-P55/P80-P84 Digital Inputs from the Chiller

P36 MO uu BO nnnn MMMM PT C

Pages 36 to 55 and 80 to 84 configure digital input points from the chiller to the network specific to the chiller per the applicable spreadsheet.

MO – Indicates the type of micro-object that represents the data in the micro panel.

uu – Indicates the particular instance of the defined micro-object.

BO – Indicates that the point represents a digital status sent from the micro panel. This status is available to the Modbus client, e.g. liquid line solenoid status. This is a system generated point descriptor.

nnnn – Indicates the pre-configured Modbus address. This address may be edited by the user but it is not stored in E². If the SRAM is corrupted in any way, this value is reset to the default value stored in the EPROM.

MMMM – Indicates the current status received from the micro panel. It is either **OPEN** or **MADE**. This is system generated.

PT – Sets the amount of time between read or write requests from the MicroGateway on a per page basis. Refer to Table 9 for the available choices.

C – Indicates the status of the communications on a per page basis. Refer to Table 10 for the available choices.

P56-P65 Coded Inputs from the Chiller

P56 MO uu AI nnnn S 2 R 0 VVVV PT C

Pages 56 to 65 configure chiller codes to specific points on the Modbus network.

MO – Indicates the type of micro-object that represents the data in the micro panel.

uu – Indicates the particular instance of the defined micro-object.

AI – Indicates that the point represents an analog value sent from the micro panel. This value is available to the Modbus client, e.g. Unit Warning Fault Code. This is a system generated point descriptor.

nnnn – Indicates the pre-configured Modbus address. This address may be edited by the user but it is not stored in E². If the SRAM is corrupted in any way, this value is reset to the default value stored in the EPROM.

S 2 – Indicates the scaling applied to the value before being made available to the Modbus client. Scaling can be set to either **0**, **1**, **2**, or **3**. Typically a **2** is set in this field, resulting in the value from the micro panel being passed directly to the Modbus client without modification. Refer to the section on scaling.

R 0 – Indicates if the data is processed using the Range feature. **0** indicates no processing. Any number other than **0** represents the section of F75 which is used to process the data. Refer to the section on range.

VVVV – Indicates the current value received from the micro panel. This is system generated.

PT – Sets the amount of time between read or write requests from the MicroGateway on a per page basis. Refer to Table 9 for the available choices.

C – Indicates the status of the communications on a per page basis. Refer to Table 10 for the available choices.

P85 SET YM TIME AND DATE PT S

Page 85 sets how often the MicroGateway sends the time and date to the chiller micro panel and indicates the communications status. If PT is set to 0s no updates occur. Refer to Table 9 for the available Poll Rate choices and Table 10 for the Status Codes.

P86 GET YM TIME AND DATE PT S

Page 86 sets how often the MicroGateway retrieves the time and date from the chiller micro panel and indicates the communications status. If PT is set to 0s no updates occur. Refer to Table 9 for the available Poll Rate choices and Table 10 for the Status Codes.

P87 to P89 Not Used

P90 OVERRUN ERRORS nnn

Page 90 indicates the number of serial communication overrun errors which have occurred since the system was reset.

P91 MESSAGE FAILURE COUNT nnn

Page 91 indicates the number of message failures which have occurred since the system was reset.

P92 POLL RESPONSE TIME nnn MAX nnn

Page 92 indicates the average time for a response from the micro panel and the maximum time for a response since the last reset of the MicroGateway.

P93 RETRY COUNT 0 EXTRA ACK 0

Page 93 indicates the number of retries for a specific message since the system was reset. This counts the number of times the system did not communicate with the micro panel. An unusually high number may indicate faulty wiring or other network interference.

P94 PRESS ENTER TO RESET YT3 TABLE

Page 94 resets the retry counter to 0.

P95 WATCHDOG 0 WAIT 0

Page 95 is used for high level diagnostics. The Watchdog indicates the number of times communication was suspended and required an internal timeout to restart. Wait shows the number of messages that are waiting for system processing.

P96 READ TIME 0412

Page 96 displays the time sent to the micro panel when the time forward is enabled in Page 85.

P97 READ DATE 22FEB

Page 97 indicates the date sent to the micro panel when the time forward is enabled in Page 85.

P98 DATA OVERFLOW FLAG SET TO YES

P98 indicates that at least one Modbus register has exceeded the maximum “data container” size. This is system generated.

P99 YORK TALK COMMS 0

P99 indicates the condition of the York Talk communications to the chiller.

If 0, communications are not functioning properly.

If 1, communications are operating properly.

F75 – Range

The range feature (Feature 75) is used to scale analog values either returned from the York Talk feature or received from the Modbus interface for specific requirements of industrial equipment. The feature uses linear regression to calculate the value of the output. The output value typically represents an analog-to-digital (ADC) count and is treated by Programmable Logic Controllers (PLC) as another input/output point.

The feature has multiple sections with each section potentially representing a specific data scaling routine. Unlike the scaling option that only allows a user to multiply or divide by 10, the range feature is fully configurable. In most cases the range feature is applied to provide a calculated output using the ADC count of the PLC as the base line. For example, a 12 bit ADC count will produce a maximum value of 4095.

P01 OUTPUT HI VALUE: 2.0

Page 1 sets the value that corresponds to the maximum output from the sensor.

P02 OUTPUT LO VALUE: 1.0

Page 2 sets the value that corresponds to the minimum output from the sensor.

P03 SENSOR HI VALUE: 2.0

Page 3 sets the maximum value that can be measured by the sensor.

P04 SENSOR LO VALUE: 2.0

Page 4 sets the minimum value that can be measured by the sensor.

P05 NUMBER RANGE UNSIGNED

Page 5 determines if the value received from or being sent to the Modbus client is treated as a signed or an unsigned number. The default is set to **UNSIGNED**. For example, if the client sends a value of **FFFF** this may be interpreted as either 65,535 or as -1.

If Page 5 is set to **UNSIGNED** then the value will be considered to be in the range of 0 to 65,535.

If Page 5 is set to **SIGNED**, then the value will be in the range of -32,768 to + 32,768.

UNSIGNED sets the range to between 0 to 65,535.

SIGNED sets the range to -32,768 to +32,768.

P06 M= 1.0 C= 0.0

Page 6 displays the calculation of slope (M) and offset (C). These points can be shown in a graphical form as shown in the figure titled Slope Calculation.

Range and Scale Theory

Scale

All York Talk analog data is stored and transferred to the MicroGateway as a floating point number. In most cases analog values processed by Modbus clients are integers. In order to transfer the numbers to Modbus, the values must be multiplied or divided by 10, depending on the direction of the transfer.

During the processing of the applications within the MicroGateway the software checks the setting of the Scale Field within the York Talk feature. The Scale Field can be set to **0**, **1**, **2** or **3**. If the Function code within the Query message is analog, Table 11 describes the expected functionality.

In the case of a setpoint being sent to the chiller, the integer value is divided by **10** before being sent to the chiller. This requires the Modbus device to send a value 10 times the required setpoint value, e.g., a value of 441 for “Leaving Chilled Water Setpoint” would be sent to the chiller as 44.1° F.

In the case of an analog value being read from the chiller, the floating point value is multiplied by **10** before being sent to the Modbus device. This requires

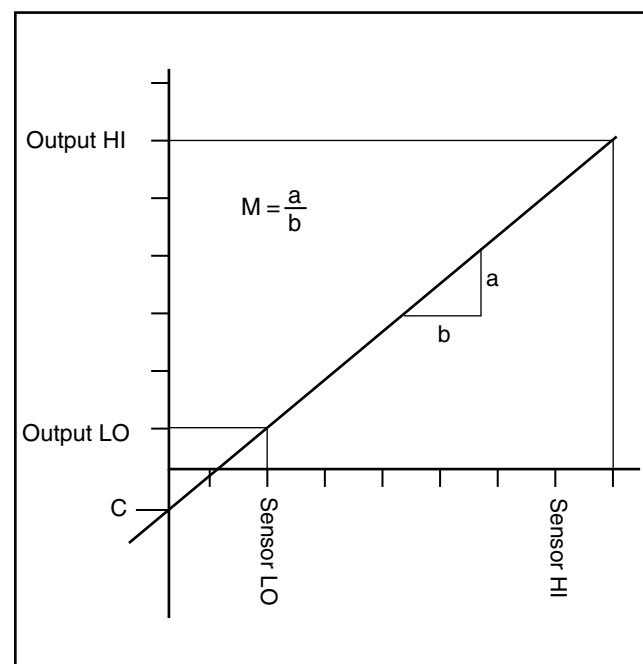

Figure 11. Slope Calculation

Table 11 – Scale Field Values

Scaling Field Setting	Purpose
0	Any value received or sent is rounded up and passes directly to its destination without any modifications. This value is unsigned.
1 (case of value being received)	Any value received is divided by 10 before passing to the appropriate data slot within the York Talk feature. This value is unsigned.
1 (case of value being sent)	Any value sent is multiplied by 10 and then rounded up before passing through to the Modbus Client. This value is unsigned.
2	Any value received or sent is rounded off and passes directly to its destination without any modifications. This value is signed.
3 (case of value being received)	Any value received is divided by 10 before passing to the appropriate data slot within the York Talk feature. This value is signed.
3 (case of value being sent)	Any value sent is multiplied by 10 and then rounded up before passing through to the Modbus Client. This value is signed.

3

There are certain values, like chiller run hours, that may exceed the resolution of the word registers used by Modbus. If this occurs, the MicroGateway's software will simply send the maximum value that it can and set a Data Overflow register to TRUE. This register is readable by the Modbus Client.

the Modbus device to divide the value by **10** in order to display the correct value, e.g., a value of 441 for “Leaving Chilled Water Temperature” would be interpreted as 44.1° F.

Certain values stored in the chiller micro panel do not require a floating point format as the value will always consist of an integer component only, e.g. “Run Hours,” “Start Count,” etc. For these points, the scale field should be set to zero.

Range (F75)

The Modbus Range feature is used to scale analog values either returned from the York Talk feature or received from the Modbus interface according to a simple

$$y = M \cdot x + C$$

equation.

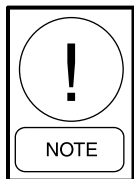

NOTE: *If a Range selection has been made, Scaling will be ignored even if it has been configured.*

Chiller Read Points

When the input to this feature is a value obtained from the York Talk points list, the OUTPUT VALUE is calculated as shown below:

$$\text{OUTPUT VALUE} = M \cdot \text{YT value} + C$$

Where $C = O/P_{HI} - M \cdot CS_{HI}$ and the YT value is the value obtained from the York Talk points list.

$$M = (O/P_{HI} - O/P_{LO}) / (CS_{HI} - CS_{LO})$$

If $(CS_{HI} - CS_{LO}) = 0$ due to an illegal configuration, then M will be set to 1.

If $(O/P_{HI} - O/P_{LO}) = 0$ due to an illegal configuration, then M will be set to 1.

Example Calculation

Typical of a standard ADC calculation

$$\begin{aligned} O/P_{HI} &= 4095 \\ O/P_{LO} &= 0 \\ CS_{HI} &= 100 \\ CS_{LO} &= 0 \end{aligned}$$

$$YT = 44.1$$

$$M = (4095 - 0)/(100 - 0) = 40.95$$

$$C = 4095 - (40.95 \cdot 100) = 0 \text{ (No offset for this example)}$$

$$\text{Output Value} = 40.95 \cdot 44.1 - 0 = 1806$$

Example Calculation

This example is typical of a standard ADC calculation with sensor offset. In order to account for out of range values

$$\begin{aligned} O/P_{HI} &= 4095 \\ O/P_{LO} &= 822 \\ CS_{HI} &= 70 \\ CS_{LO} &= 20 \end{aligned}$$

$$YT = 44.1$$

$$M = (4095 - 822)/(70 - 20) = 65.46$$

$$C = 4095 - (65.46 \cdot 70) = -487 \text{ (Offset for this example)}$$

$$\text{Output Value} = 65.46 \cdot 44.1 - 487 = 2400$$

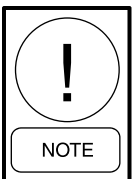

NOTE: A value below 20° F would produce an output value below 822, which is regarded as the sensor malfunction limit.

Chiller Write Points

When the input to this feature is a value obtained from the Modbus network the OUTPUT VALUE is calculated as shown below:

$$\text{OUTPUT VALUE} = (MD - C)/M$$

Where $C = O/P_{HI} - M \cdot CS_{HI}$ and the MD value is the value obtained from the Modbus network.

$$M = (O/P_{HI} - O/P_{LO})/(CS_{HI} - CS_{LO})$$

If $(CS_{HI} - CS_{LO}) = 0$ due to an illegal configuration, then M will be set to 1.

If $(O/P_{HI} - O/P_{LO}) = 0$ due to an illegal configuration, then M will be set to 1.

Example Calculation

Typical of a standard ADC calculation

$$\begin{aligned} O/P_{HI} &= 4095 \\ O/P_{LO} &= 0 \\ CS_{HI} &= 100 \\ CS_{LO} &= 0 \end{aligned}$$

$$MD = 1650$$

$$M = (4095 - 0)/(100 - 0) = 40.95$$

$$C = 4095 - (40.95 \cdot 100) = 0 \text{ (No offset for this example)}$$

$$\text{Output Value} = (1650 - 0)/40.95 = 40.3$$

Example Calculation

Typical of a standard ADC calculation with sensor offset in order to account for out of range values

$$\begin{aligned} O/P_{HI} &= 4095 \\ O/P_{LO} &= 822 \\ CS_{HI} &= 60 \\ CS_{LO} &= 38 \end{aligned}$$

$$MD = 1650$$

$$M = (4095 - 822)/(60 - 38) = 148.77$$

$$C = 4095 - (148.77 \cdot 60) = -4831 \text{ (Offset for this example)}$$

$$\text{Output Value} = (1650 - (-4831))/148.77 = 43.6$$

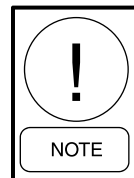

NOTE: A value below 822 would produce an output value below 38°, which would be regarded as an invalid input to the chiller as leaving chilled water setpoint (the high and low limits used in this example).

Modbus Registers

Modbus registers are numbered in the following manner:

Table 12 – Modbus Range

DESCRIPTION	RANGE	DATA TYPE
Output Coils	1 to 9999	0X
Input Status	10001 to 19999	1X
Input Registers	30001 to 39999	2X
Holding Registers	40001 to 49999	3X

The number of coils and registers are unique to each piece of Modbus hardware. The Modbus MicroGateway is limited to processing the number of inputs and registers as stated in Table 13. Requests received for numbers greater than that specified return an exception error “Invalid Data.”

Table 13 – Modbus Inputs and Registers

Output Coils	800 coils
Input Status	800 inputs
Input Registers	100 registers
Holding Registers	100 registers

Modbus functions use an offset address to determine where each piece of data resides within memory. The tables shown in the Appendix reference the Modbus address used by a client to read or write data. The actual address contained in the message is always

$n-1$

where n is the address shown in the Appendix tables.

As the Modbus MicroGateway serves only as a slave device, the master transmits a query in the form of a particular function and the Modbus MicroGateway responds to the query as follows:

Modbus Function 01 (Read Coil Status) – Reads the ON/OFF status of discrete outputs (0X references, coils) in the slave. The query message specifies the starting coil and quantity of coils to be read.

The coil status in the response message is packed as one coil per bit of the data field. Status is indicated as: 1 = ON; 0 = OFF. The LSB of the first data byte contains the coil addressed in the query. The other coils follow toward the high order end of this byte, and from ‘low order to high order’ in subsequent bytes.

If the returned coil quantity is not a multiple of eight, the remaining bits in the final data byte will be padded with zeros (toward the high order end of the byte). The Byte Count field specifies the quantity of complete bytes of data.

Modbus Function 02 (Read Input Status) – Reads the ON/OFF status of discrete inputs (1X references) in the slave. The query message specifies the starting input and quantity of inputs to be read.

The input status in the response message is packed as one input per bit of the data field. Status is indicated as: 1 = ON; 0 = OFF. The LSB of the first data byte contains the input addressed in the query. The other inputs follow toward the high order end of this byte, and from ‘low order to high order’ in subsequent bytes.

If the returned input quantity is not a multiple of eight, the remaining bits in the final data byte are padded with zeros (toward the high order end of the byte). The Byte Count field specifies the quantity of complete bytes of data.

Modbus Function 03 (Read Holding Registers)

–Reads the binary contents of holding registers (4X references) in the slave. The query message specifies the starting register and quantity of registers to be read.

The register data in the response message are packed as two bytes per register with the binary contents right justified within each byte. For each register the first byte contains the high order bits and the second contains the low order bits.

Modbus Function 04 (Read Input Registers)

– Reads the binary contents of input registers (3X references) in the slave. The query message specifies the starting register and quantity of registers to be read.

The register data in the response message is packed as two bytes per register, with the binary contents right justified within each byte. For each register, the first byte contains the high order bits and the second contains the low order bits

Modbus Function 05 (Force Single Coil) – Forces a single coil (0X reference) to either ON or OFF.

The query message specifies the coil reference to be forced. Coils are addressed starting at zero, i.e. coil 1 is addressed as 0. The requested ON/OFF state is specified by a constant in the query data field. A value of FF 00 hex requests the coil to be ON. A value of 00 00 requests it to be OFF. All other values are illegal and will not affect the coil.

The normal response is an echo of the query, returned after the coil state has been forced.

Modbus Function 06 (Preset Single Register)

–Presets a value into a single holding register (4X reference). When broadcast, the function presets the same register reference in all attached slaves.

The query message specifies the register reference to be preset. Registers are addressed starting at zero, i.e. register 1 is addressed as 0. The requested preset value is specified in the query data field.

The normal response is an echo of the query, returned after the register contents have been preset.

Modbus Function 08 (Diagnostics) – The Modbus MicroGateway supports sub-function 00 (Return Query Data). When a Function (08), sub-Function (00 00) is received from the Modbus client, the data passed in the query data field is returned (looped back) in the response (the entire response message is identical to the query). This is used as a simple way to prove out the connectivity between the Client and Server.

Modbus Function 15 (Force Multiple Coils)

– Forces each coil (0X reference) in a sequence of coils to either ON or OFF.

The query message specifies the coil references to be forced. Coils are addressed starting at zero, i.e. coil 1 is addressed as 0. The requested ON/OFF states are specified by contents of the query data field. A logical “1” in a bit position of the field requests the corresponding coil to be ON. A logical ‘0’ requests it to be OFF.

The normal response returns the slave address, function code, starting address, and quantity of coils forced.

Modbus Function 16 (Reset Multiple Registers)

–Presets values into a sequence of holding registers (4X references).

The query message specifies the register references to be preset. Registers are addressed starting at zero, i.e. register 1 is addressed as 0. The requested preset values are specified in the query data field. Data is packed as two bytes per register.

The normal response returns the slave address, function code, starting address, and quantity of registers preset.

Table 14 – Modbus Function 17

Slave ID	Hex	
Slave Address	11	Will assume the actual slave address
Function	11	Decimal 17
Byte Count	09	Device specific, but is 9 in this case
Device Type	09	984 controller
PLC Status		FF (00 = OFF, FF = ON)
Page Memory	02	
RAM Memory	02	
Logic Memory	02	
Machine State 1	01	16 bit nodes
Machine State 2	A2	
Machine Stop Code 1	00	
Machine Stop Code 2	00	
CRC Byte 1		Calculation
CRC Byte 2		Calculation

Modbus Function 17 (Report Slave ID) – The Modbus MicroGateway is not a PLC and, as such, does not have a Slave ID as specified in the Modbus specification document. However, in order to accommodate this request, the Modbus MicroGateway responds with a Modicon 984 controller signature message as shown in the table titled Modbus Function 17.

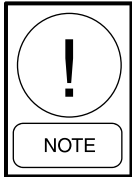

NOTE: In most instances the default Modbus registers are used, as shown in the tables in the Appendix. A user may, however, configure any page within any of the York Talk features to any unique 4-digit Modbus address. With the exception of three specific addresses within York Talk 2 (shown in the Appendix), no other addresses are stored in E². To retain the modified Modbus address to York Talk correlation, a customized EPROM must be created.

THIS PAGE INTENTIONALLY LEFT BLANK

SECTION 4

HARDWARE

GENERAL

The Modbus MicroGateway has five LEDs that are used as indicators of communication and operating status. Two LEDs are associated with each communication port and indicate when the MicroGateway is receiving or transmitting information. The STATUS LED serves three purposes:

1. Indicates proper operation of the Modbus MicroGateway.
2. Indicates a unit failure.
3. Verifies selection of the Quick Start configurations.

STATUS LED

Normal Operation

When the Modbus MicroGateway is in Operation Mode and working properly, the STATUS LED flashes continuously once per second. The transmit and receive LEDs flash when information is transferred to or from each port.

The STATUS LED also verifies the correct selection of a Quick Start feature. Refer to Table 15 for the number of flashes for each Quick Start selection.

However, if the STATUS LED flashes several times within a cycle (a cycle is a number of flashes and a 3.5 second off time) and no Quick Starts are selected, an advisory condition is present. This cycle will continue to indicate the advisory condition until the cause of the condition is removed.

Advisory Conditions

Two (2) flashes of the STATUS LED indicate a York Talk communication failure between the chiller micro panel and the Modbus MicroGateway. The condition could be due to faulty wiring, incorrect setup of the chiller or simply an unplugged network cable. For any York Talk features enabled in Feature 70 but not operational, i.e. sending and receiving messages correctly, the STATUS LED flashes 2 times per cycle.

When the Quick Start is set to 128, the STATUS LED flashes 3 times per cycle, indicating that the E² is being updated with data from the EPROM. Once the update is complete, the STATUS LED flashes once per cycle indicating the update cycle is complete.

Failures

If the MicroGateway's hardware seriously malfunctions, the watchdog circuit will not be updated and the STATUS LED flashes in unison with the processor reset signal. This is typically once every 1.5 seconds. The STATUS LED continues to flash until the watchdog circuit once again starts to be updated by the system.

A serious hardware malfunction would be characterized by the failure of the processor, SRAM, E² or EPROM (or the removal of the EPROM).

A catastrophic hardware failure may leave the STATUS LED either in the ON or OFF state. This situation could be caused by the above mentioned hardware malfunctions, a malfunctioning power supply, system error condition or communications test failure (when using Quick Start 243). System errors can result from an intermittent hardware failure (the result of electrical noise) which can corrupt the system's memory, resulting in unpredictable behavior.

A user usually cannot determine the difference between a system error and a catastrophic failure. If the STATUS LED is observed to be either permanently ON or OFF, the user should de-configure the MicroGateway by disabling the capacitor to clear out the contents of the SRAM and performing the Power Down/Power Up. This may cure the problem if it was due to a hardware glitch. Otherwise, the MicroGateway may need to be replaced.

Port LEDs

Each communication port is supported with two diagnostic LEDs. The red LEDs show transmissions while the green LEDs show data reception.

Port 1 LEDs

When a York Talk Feature is enabled using Quick Start, Port 1 begins transmitting requests to the micro panel. Even if there is no micro panel actually connected to the MicroGateway, the MicroGateway attempts to communicate. The types of exchanges are listed below:

York Talk 1 Connection (RS232) – The red TX LED flashes for a couple of seconds and then the whole process will be repeated every Poll Time, (currently this defaults to 30 seconds). If a micro panel is connected to the MicroGateway it responds with a reply message causing the green RX LED to flash for about 10 seconds, although this depends upon the type of chiller.

York Talk 2 Connection (RS485) – The red TX LED and the green RX LED flashes together for a couple of seconds and then the whole process is repeated every Poll Time, (the Poll Time default is 30 seconds). If a micro panel is connected to the MicroGateway it responds with a reply causing the green RX LED to flash for

about 20 seconds, although this depends upon the type of chiller.

The TX and RX LEDs flash together because TX and RX lines are connected through the RS485 transceiver. When the MicroGateway transmits a message it also receives it.

York Talk 3 Connection (RS232) – The LED pattern is very much dependent if an OptiView micro panel is connected or not.

- a. On power up the Modbus MicroGateway requests the time from the OptiView micro panel. The user can observe the red TX LED flashing during this process. If the micro panel responds with the time, indicated by green LED flashes, the MicroGateway assumes the communication link is established. The MicroGateway then proceeds to send the engineering units to the micro panel and wait for a positive acknowledgement. Once this is received the MicroGateway proceeds with normal operation.
- b. If no acknowledgement is received after three attempts, the MicroGateway assumes the communication link is bad and starts requesting the time from the micro panel. Simultaneous red and green LED flashes characterize normal communications.

Table 15 – LED Flash Rates

FLASHES	INDICATES	FLASHES	INDICATES
OFF	Communications Test Failure (Node Switch=243 only)	8	Node Switch 251 Selected
Steady OFF or ON	Hardware Errors, EPROM Failure or E ² Failure*	9	Node Switch 250 Selected
Steady OFF or ON	System Errors	10	Node Switch 249 Selected
2	York Talk Communication Failure	11	Node Switch 248 Selected
3	Updating the Software to EPROM Defaults	12	Node Switch 247 Selected
4	Node Switch 255 Selected	13	Node Switch 246 Selected
5	Node Switch 254 Selected	14	Node Switch 245 Selected
6	Node Switch 253 Selected	15	Node Switch 244 Selected
7	Node Switch 252 Selected	1	Node Switch 243 Selected
		19	Node Switch 240 Selected

* Indicates a Fatal Hardware error that requires the hardware to be replaced.

Port 2 and Port 3 LEDs

A Modbus Master is connected to Port 2 or 3 and is responsible for polling the MicroGateway. Every poll from the Master results in green RX LED flashes on the MicroGateway. When the MicroGateway responds, the red TX LED flashes. The polling frequency (LED flash rate) is totally dependent on the configuration of the Modbus client.

If a communication error occurs between the Modbus MicroGateway and Modbus network device, it is not registered by the MicroGateway. The Modbus Master does not receive the correct response to its request indicating that it is not communicating with the MicroGateway. Refer to the Modbus device documentation for additional information.

Dimly Lit LEDs

Sometimes the green RX LED on the MicroGateway monitoring an RS485 transceiver may appear to be dimly illuminated, even if there is no activity on the network. This is an indication that the bias of the transceiver is being affected. There are usually two reasons for this type of problem; a constant electrical coupling onto the network wires or a defective RS485 transceiver.

To ensure that the problem is not related to an installation problem:

- Ensure that no high voltage electrical signals are in close proximity to the MicroGateway.
- Provide a good ground connection for the MicroGateway.

If a defective transceiver requires replacement refer to the procedure shown later in this section.

Communications During Quick Start

If the node switch is set for a value between 201 and 255 or 128, the LEDs process this request first and ignore any other advisory conditions which may exist. Within these reserved addresses a system advisory condition takes lower priority over all flash rates.

Once the node switch is reset to the network address (between 0 and 200) other conditions, such as a York Talk failure, can be registered.

Updating Firmware

Occasionally, it may be necessary to upgrade the firmware in the MicroGateway or reset the configuration to the default, factory setting. A routine can be selected by setting the node switch to 128 (similar to a Quick Start) which forces the MicroGateway to use the default configuration stored in EPROM.

Normally the current settings are retrieved from E² each time the MicroGateway is started. When node address 128 is selected the priority of the information which is loaded in SRAM is changed. Information is retrieved from the EPROM first and then the information stored in E² is overwritten by the EPROM defaults.

A STATUS LED flash rate of 3 flashes per cycle indicates the MicroGateway is transferring data from the EPROM. When complete, the STATUS LED flashes at a once per cycle rate.



WARNING: Personnel should always be grounded before touching the MicroGateway. An Anti-Static Ground Strap is recommended. As a minimum, firmly grasp grounded metal before working on the unit.

To update the firmware:

1. Remove the power to the MicroGateway by pulling the power harness from **J1**.
2. Remove the Capacitor Enable jumper at **JP7** for a minimum of 10 seconds. This corrupts the SRAM memory.
3. Install the Capacitor Enable jumper at **JP7**.
4. If necessary, remove the EPROM using a removal tool. Carefully install the new EPROM, making sure pin 1 is located properly.
5. Set the node switch to **128**.
6. Insert the power harness into connector **J1**. The STATUS LED should flash **3** times per cycle.

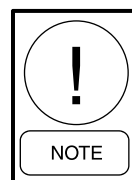

NOTE: If the update process is short (not much data to transfer) the 3 flashes may not be visible.

- When the STATUS LED begins to flash once per cycle, the MicroGateway can be configured using either a Quick Start address or connecting a computer terminal.

Part Replacement

Certain items can be replaced if found to be malfunctioning. Typical items are the RS485 drivers (transceivers), EPROM Circuit Board or Power Board.

Chip Replacement



DANGER: Always disconnect the line voltage to the MicroGateway before removing any components.



WARNING: Personnel should always be grounded before touching the MicroGateway. An Anti-Static Ground Strap is recommended. As a minimum, firmly grasp grounded metal before working on the unit.

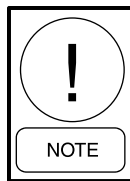

NOTE: If upgrading the software to a new version, refer to the section on **UPDATING FIRMWARE**.

To replace either the EPROM or the RS485 drivers (transceivers):

- Disconnect the line voltage power supply to the MicroGateway.
- Note the position of the notch in the chip. Using a chip removal tool, remove the chip from the MicroGateway card.
- On the replacement chip, locate the notch. Carefully install the replacement chip in the socket with the notch in the same location as noted during removal.

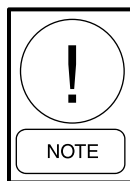

NOTE: The notch indicates the location of pin 1 on the chip.

- Reconnect the line voltage power supply. If necessary, reconfigure the MicroGateway using Quick Start or a computer terminal.

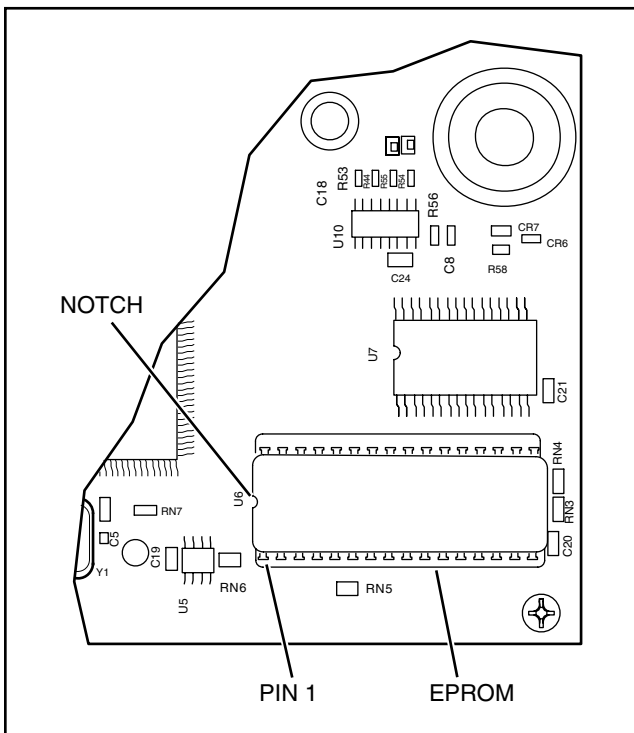

Figure 12. EPROM Orientation

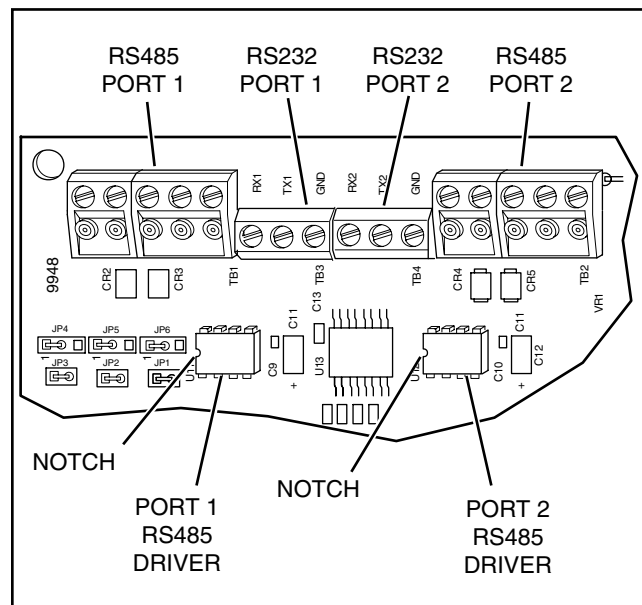

Figure 13. RS485 Drivers

Fuse Replacement

For MicroGateways within their own enclosure (non-OptiView units) the Power Board is protected by two fuses. The fuse in location FU1 is a 5 x 20 Fast-Blow, 1.25 A, 250 volt fuse. It protects the board against circuit overload on the low voltage side of the Power Board. The fuse in location FU2 is a 5 x 20 Fast-Blow, 150 mA, 250 volt fuse. It protects the MicroGateway transformer from overload.



DANGER: Always disconnect the line voltage to the MicroGateway before removing any components.



WARNING: Personnel should always be grounded before touching the MicroGateway. An Anti-Static Ground Strap is recommended. As a minimum, firmly grasp grounded metal before working on the unit.

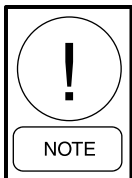

NOTE: Inserting a replacement fuse with no power connected may cause the LED to illuminate momentarily due to the energy stored by capacitor on the Power Board.

If the Power Board is suspected of malfunctioning:

1. Disconnect the line voltage power supply to the MicroGateway.
2. Remove the power harness from **J1** to disconnect power.
3. Place probes from a voltmeter into the power harness plug.
4. Reconnect the line voltage power supply to the MicroGateway. Note the voltage at the power harness connector. Voltage should be in the range of 12 to 30 volts DC.
 - a. If the voltage measures within this range, the Power Board is functioning properly.
 - b. If not proceed to step 5.
5. Disconnect the line voltage power supply to the MicroGateway.

6. Reconnect the power harness to connector **J1**. This will discharge any stray voltage remaining on the Power Board capacitor.
7. Remove the fuse covers and fuses on the Power Board. Install new fuses of the appropriate size.

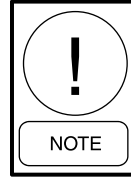

NOTE: It is recommended that both fuses be replaced if either is questionable.

8. Reconnect the line voltage power supply to the MicroGateway.

If the MicroGateway fails to work, proceed to the Power Board Replacement procedure.

Power Board Replacement



DANGER: Always disconnect the line voltage to the MicroGateway before removing any components.



WARNING: Personnel should always be grounded before touching the MicroGateway. An Anti-Static Ground Strap is recommended. As a minimum, firmly grasp grounded metal before working on the unit.

For MicroGateways with their own enclosure (non-OptiView units) the Power Board can be replaced if it is determined to be faulty. Before replacing the board, check the two fuses located on the board.

To replace the board:

1. Disconnect the line voltage power supply to the MicroGateway.
2. Remove connector **TB1** (line voltage supply) from the Power Board.
3. Remove the power harness from **J1** on the circuit board to disconnect power.
4. Remove the four screws and washers securing the Power Board to the enclosure. Note that two of the screws also secure ground wires to the board. Remove the board.

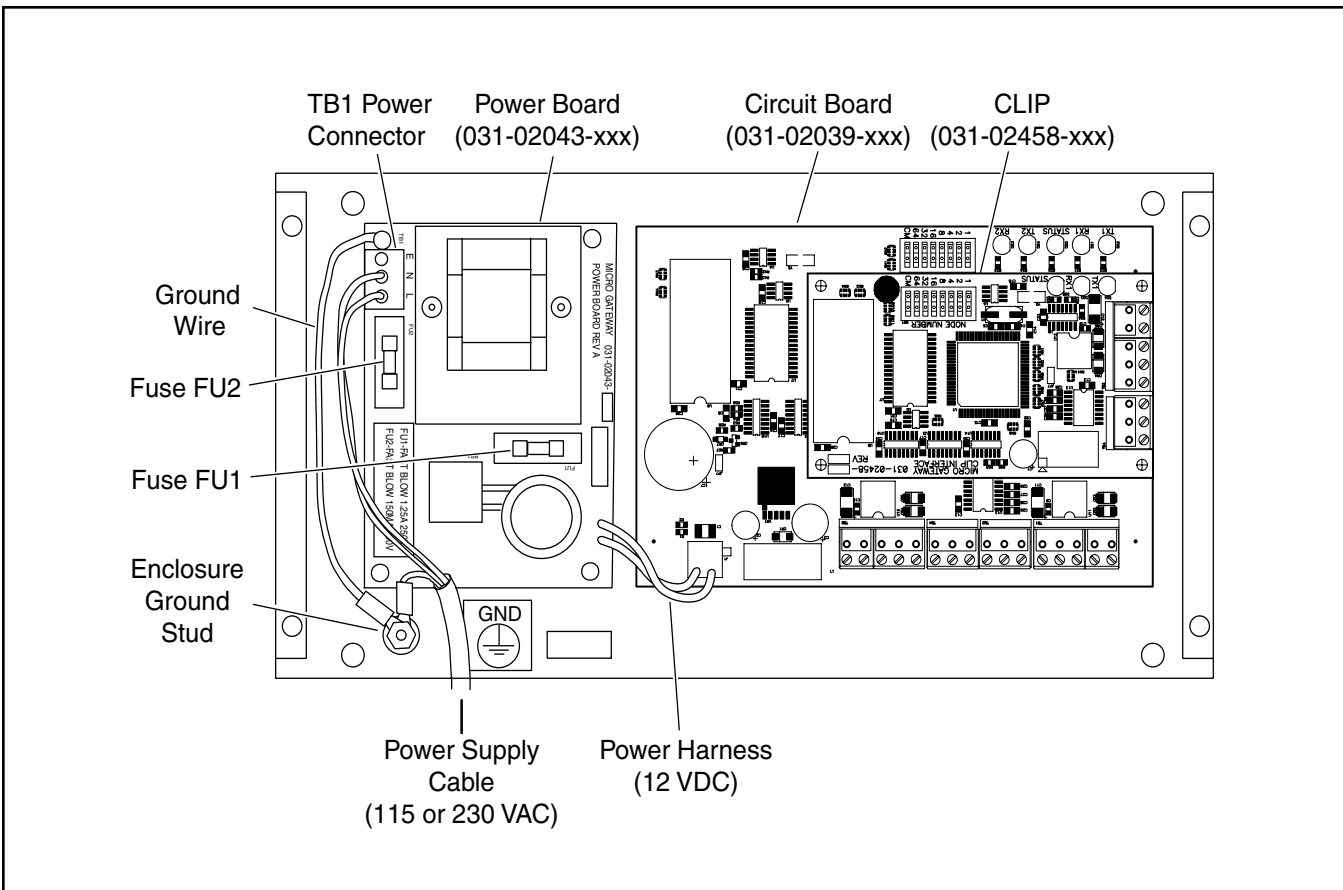
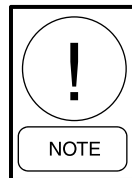

Figure 14. Power Board Connections

5. Position the replacement board in the enclosure and secure with the two screws and washers which did not also secure ground wires.
6. Insert and tighten the screws and washers which secured the ground wires to the enclosure and enclosure cover.
7. Connect the line voltage supply cable to **TB1** on the Power Board.
8. Apply the normal line voltage supply to the Power Board. Check to make sure operation seems normal.
9. Place the power connector into J1 on the circuit board. Check to make sure operation seems normal.

Circuit Board Replacement

If the circuit board is found to be faulty, it can be replaced. It is recommended that the EPROM be removed from the faulty board and reinstalled into the new, replacement board.



NOTE: If the circuit board is faulty, the EPROM may still function properly. By removing the EPROM, the original version of the software can be retained.

If the EPROM is found to be faulty, refer to the section on upgrading firmware.

To replace the circuit board:

1. Disconnect the line voltage power supply and network cables to the MicroGateway.

2. Remove the connector **J1** from the circuit board or from the OptiView micro panel power source.
3. Using a chip removal tool, remove the EPROM from socket **U6**.
4. Remove the four screws securing the board to the enclosure or OptiView micro panel.
5. Position the replacement circuit board in the enclosure or OptiView micro panel. Secure with four washers and screws.
6. Install the EPROM previously removed.
7. Connect the power to connector **J1**.
8. Turn on the line voltage supply and check for proper operation.
9. Reinstall any covers removed to gain access to the circuit board.

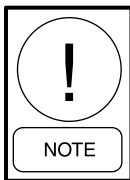

NOTE: *If a new EPROM is to be installed, refer to Updating Firmware.*

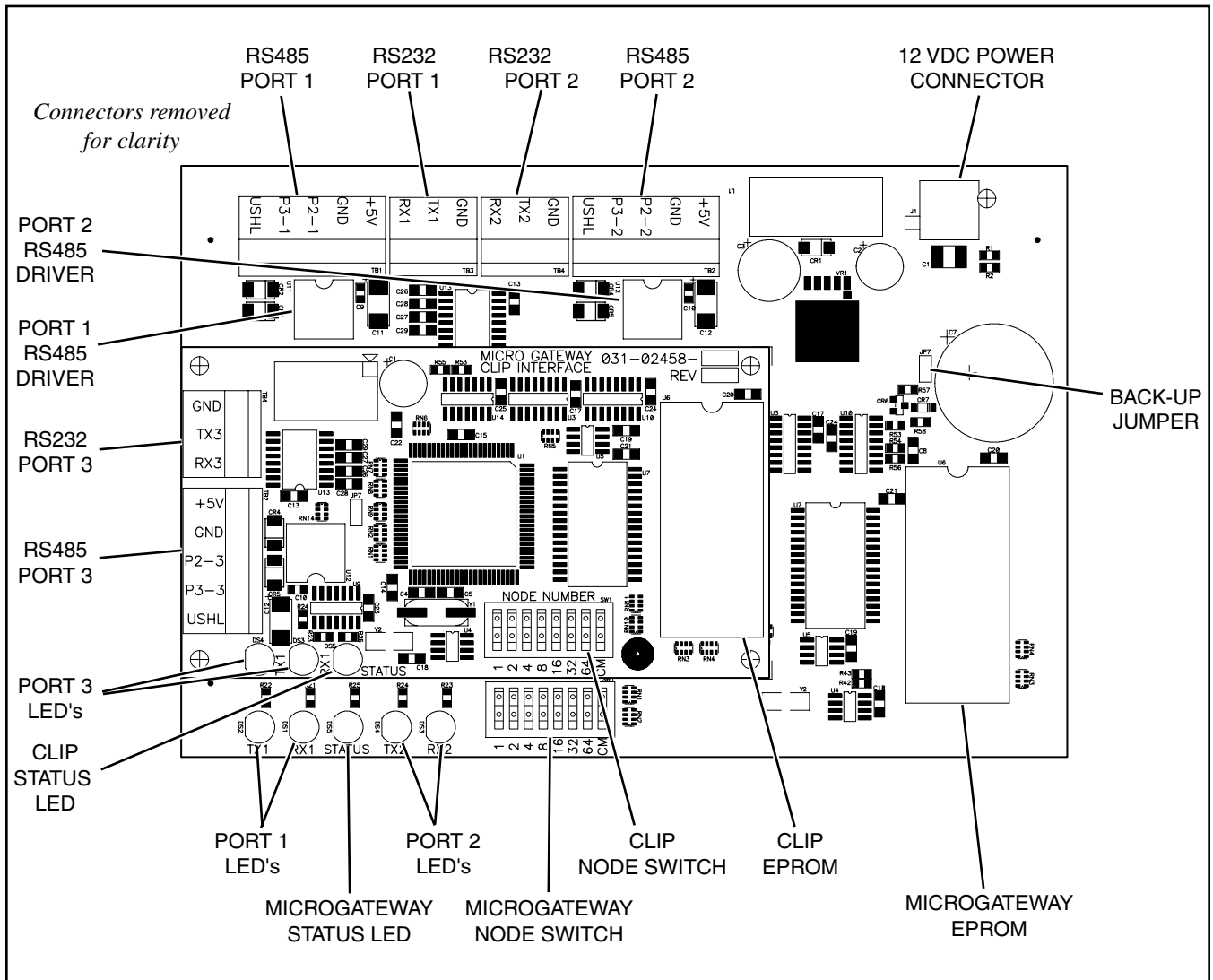

Figure 15. Circuit Board Components

THIS PAGE INTENTIONALLY LEFT BLANK

SECTION 5

TROUBLESHOOTING

This section provides a guide for troubleshooting should a problem develop. A chart has been created to help in diagnosis of faults. To use the chart, locate the appropriate symptom and review the possible causes for that symptom. After the most likely cause is determined, follow the suggestions listed in the solutions column.

While this Troubleshooting Guide does not claim to include all possible symptoms or solutions, it can simplify troubleshooting and assist in determining the causes of a malfunctioning device.

Error Processing

When the Modbus MicroGateway receives a message that it does not support, it answers with an exception response message. The message returned is always in the form of:

Slave Address
Function
Exception Code
CRC

The Function returned in the message is **ORed** with the **80H**. For example, if the Query Function were a **01**, then the returned Function would be **81H**. The following conditions return an Exception Code error message:

If the Modbus MicroGateway receives a Function code that is not supported, it will return an **01** (Illegal Function) as the exception code.

If the Modbus MicroGateway receives a message containing an **illegal data address** it will return a **02** (Illegal Data Address) as the exception code. For example, if the MicroGateway receives a message with a data address of **92**, an exception code **02** will be returned.

If York Talk 1 is selected, then only the following range of addresses is valid:

001 to 060 (Analog in Section #1)
061 to 091 (Digital in Section #1)

If York Talk 2 is selected, then only the following range of addresses is valid:

001 to 060 (Analog in Section #1)
061 to 091 (Digital in Section #1)
101 to 160 (Analog in Section #2)
161 to 191 (Digital in Section #2)

If York Talk 3 is selected, then only the following range of addresses is valid:

001 to 060 (Analog in Section #1)
061 to 091 (Digital in Section #1)
101 to 160 (Analog in Section #2)
161 to 191 (Digital in Section #2)
201 to 260 (Analog in Section #3)
261 to 291 (Digital in Section #3)
301 to 360 (Analog in Section #4)
361 to 391 (Digital in Section #4)

If the Modbus MicroGateway receives a message containing an **illegal data value** it will return a **03** (Illegal Data Value) as the exception code.

For example, if a value is written into a digital register using **Function 05**, then only two valid states are acceptable, **00** or **FF 00**, and other values are considered invalid.

Special Registers

Special Registers are items which can be viewed through various types of Modbus interface software. York recommends use of ModScan32 from WinTECH Software Design®. This simple tool allows the technician to connect a portable computer directly to the MicroGateway/CLIP to verify correct Modbus data output from Port 2/3. Additional information on WinTECH is available at

www.win-tech.com

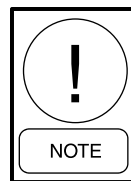

NOTE: A portable computer typically connects through RS232. To verify Modbus data communication using ModScan32 on the RS485 layer, an RS232 to RS485 converter can be used. York recommends Part No. 724-746-5500 from Black Box Corp. (www.blackbox.com).

Using interface software the following items can be viewed.

Modbus View

When the node switch selects a Quick Start feature from **246** to **255** at the MicroGateway, the information is visible to the Modbus network. Modbus register **412** receives the information and stores it until a different node address is selected.

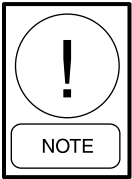

NOTE: *Quick Start selections of 243, 244 and 245 are not copied to Modbus Register 412.*

York Talk Status (401)

This Register indicates the binary status of the York Talk communication's link. If the link is OK then the status flag will be set to a **1**, if the link has failed the flag will be set to a **0**.

Register **401** is used to display the status of the York Talk communications that have been configured in Page 3 of Feature 70.

If York Talk 2 has been selected, then Register **401** will only show the status of the link for the Master, as there is no way in which to determine the Slave's status.

If York Talk 3 has been selected, then Page 99 of the first section is used to show the status of the communication's link. Page 99 of all the other sections simply reflects what is displayed on Page 99 of the first section. (Any communication failure on any page in any section automatically sets this flag to a 0). Register **401** is used to display this status. This data may be read by using the following Functions: **01**, **02**, **03** for reading and **05** for writing.

Data Overflow (402)

This binary register is set to **1** if a value received from the York Talk features either conditioned or unconditioned exceeds the resolution of any word registers used by the Modbus client.

If **SIGNED** has been selected as the numbering system of choice, then the resolution is:

between -32,768 to +32,768

In order to select a **SIGNED** numbering system on a per page basis the following procedure needs to be followed:

RANGE = 0 AND (SCALE = 1 OR 3)

or the RANGE = nn (where nn = 1 to 50) and F75 (section nn, Page 05 is configured for **SIGNED**)

In all other cases the data will be considered as **UNSIGNED**.

If **UNSIGNED** has been selected, the resolution is
0 to 65,535.

When a data overflow is present Register **402** is set to **1**. This data may be read by using the following Functions: **01**, **02**, **03** for reading and **05** for writing.

The overflow flag is reset by power cycling the MicroGateway or by writing a **0** to the above-defined register. The data overflow condition is checked just prior to it being sent to the Modbus client.

Register **403** has been allocated to display the address of the last register that has resulted in a data overflow condition. This register always reflects the most recent cause of the data overflow condition.

Time and Date Registers (404, 405 & 413)

When York Talk 3 is configured in the MicroGateway a Modbus Client may retrieve time and date. Register **404** is used to display TIME (HHMM), register **405** is used to display the DATE (MMDD), and register **413** is used to display the year (YYYY). This data may be read by using the following Functions, **03**, and **04**.

Timing Registers (406 & 407)

Register **406** is used to display the current response time of the Modbus MicroGateway. Specifically, it measures the time between the last character of the request message to the last character of the response message. The units of this register are "system ticks." To convert into seconds, this value needs to be multiplied by 256 microseconds.

Register **407** is used to display the maximum response time since the system was reset. Both of these registers are supported by Functions **03** and **04**. Registers **408** and **409** are used to display the number of USART errors that the MicroGateway has experienced.

Mode Register (410)

Register **410** is used to display the addressing mode being used. If this register is set to **0**, then the MicroGateway is using the default set of addresses, if it is set to **1**, then the user has overridden the defaults. This data may be read by using the following Functions, **01**, **02** and **03**. If the MicroGateway is configured with addresses other than the defaults the system performance is reduced.

SYMPTOM	PROBABLE CAUSE	SOLUTION
STATUS LED does not light.	<p>No power to the unit.</p> <p>Blown fuse.</p> <p>Malfunctioning Power Board.</p> <p>EPROM removed from board</p>	<p>Check power supply for correct voltage (115 or 230 v AC).</p> <p>Ensure line voltage power supply is turned “on.”</p> <p>Replace both fuses.</p> <p>Check for 12 volts DC at J1.</p> <p>Replace defective components.</p> <p>Install EPROM.</p>
Chiller TX1/RX1 LEDs do not flash (observe for a minimum of 30 seconds).	<p>Port not setup correctly.</p> <p>Chiller micro panel not communicating.</p> <p>Malfunctioning RS485 driver (applies to RS485 communications only).</p> <p>Incorrect wiring at connector.</p> <p>RX and TX swapped.</p>	<p>Use Quick Start to ensure port settings are correct.</p> <p>Ensure chiller is configured correctly. Refer to chiller documentation.</p> <p>Replace RS485 driver.</p> <p>Ensure wires are installed properly.</p> <p>Ensure wires are installed properly.</p>
Third party TX2/RX2 LEDs do not flash.	<p>Port not set correctly.</p> <p>Third-party device not communicating.</p> <p>Malfunctioning RS485 driver (applies to RS485 communications only).</p> <p>Incorrect wiring at connector.</p> <p>RX and TX swapped.</p>	<p>Use Quick Start to ensure port settings are correct.</p> <p>Ensure third party device is configured correctly. Refer to the third-party documentation.</p> <p>Replace RS485 driver.</p> <p>Ensure wires are installed properly.</p> <p>Ensure wires are installed properly.</p>
Third party is communicating but some values are suspected to be incorrect.	Third party attributes not set correctly.	<p>Third party address and object attributes are not set correctly. Refer to third party documentation.</p> <p>Check scale and range calculations.</p>
Exception status returned.	Query request out of range.	Check query for number of points requested.

SYMPTOM	PROBABLE CAUSE	SOLUTION
<p>York Talk 3 TX (red) LED blinks continuously.</p>	<p>Incorrect wiring to OptiView micro panel.</p> <p>Jumper not installed in JP27 on micro panel.</p> <p>OptiView micro panel is not configured for ISN communications.</p> <p>Faulty OptiView micro panel.</p> <p>Faulty MicroGateway.</p>	<p>Correct the wiring.</p> <p>Install jumper. Refer to Installation Manual.</p> <p>Configure micro panel to use ISN as the source.</p> <p>Replace micro panel.</p> <p>Replace MicroGateway.</p>
<p>STATUS LED flashes once every 2 seconds.</p>	<p>Low input supply voltage.</p> <p>No EPROM.</p> <p>Faulty MicroGateway.</p>	<p>Measure voltage at J1 to ensure it is greater than 12 volt DC. If not, replace Power Board or power source at micro panel.</p> <p>Replace or install EPROM.</p> <p>Replace MicroGateway.</p>

APPENDIX

Previous issues of this manual included a list of the micro-objects loaded for each chiller/Quick Start. These micro-objects have changed and will continue to change as enhancements are made to each model because of the constant improvement process followed by YORK.

Please note that specific micro objects are loaded for OptiView chiller models using York Talk 3. For chillers utilizing York Talk 1 and 2, only the Modbus address and relevant scale are loaded for each Page.

A sample page is provided but it may or may not match what is actually loaded into the MicroGateway. It is provided as a guide to highlight the fields that are stored in E². These values will remain if a power failure occurs beyond the capacitor capability (approximately 3 days). Items not highlighted are stored in BRAM and will revert to the EPROM defaults in the event of a power failure.

Points lists are available from the York Controls website at

<http://www.intranet.york.com/web0147>

This website should be referenced for each job to ensure that the most recent points lists are obtained.

The York Controls website offers two lists: one is the York Talk Points List as programmed in the chiller micro panel. The second list references the Modbus RTU parameters associated with each Page against the chiller type. The Quick Start feature simplifies the setup required by many of the different types of YORK chillers by assigning a specific scale to each page.

The chiller types that have scaling fully supported by Quick Start are:

- All York Talk 3 OptiView chillers.
- York Talk 2 @ 1200 baud
 - YK with SSS and VSD
 - YT with SSS and VSD
 - YS with SSS
- York Talk 2 @ 4800 baud with 1 section
 - Reciprocating (2 compressor)
 - Air-cooled screw (2 compressor)
 - YCAS Style D (2 compressor)
- York Talk 2 @ 4800 baud with 2 sections
 - Reciprocating (4 compressor)
 - Air-cooled screw (4 compressor)
 - YCAS Style D (4 compressor)

Other chiller types may exhibit instances where two different chiller models use the same page in a way that requires different scaling. In these cases, the user must manually edit any scaling parameters. As scaling is stored in E², any new selection is saved as long as no Quick Starts are invoked, overwriting the setting.

Table A-1 – Sample York Talk Points List

F74S01 Page No	Micro Object	Modbus Address	F74 Scale Field	Scale Factor	F74 Range Field	Default Initial Value	Poll Interval	Modbus Functions	Point List Description
3	AV.1	1	3	Div 10	0	0000	5	03,06,16	
4	AV.2	2	3	Div 10	0	0000	5	03,06,16	
5		3	3	Div 10	0	0000	5	03,06,16	
6		4	3	Div 10	0	0000	5	03,06,16	
7	BV.1	61		N/A		OPEN	5	01,03,05,06,15,16	
8		62		N/A		OPEN	5	01,03,05,06,15,16	
9	BV.10	63		N/A		OPEN	5	01,03,05,06,15,16	
10		64		N/A		OPEN	5	01,03,05,06,15,16	
11	AI.1	5	3	X 10	0		5	03,04	
12	AI.2	6	3	X 10	0		5	03,04	
13	AI.5	7	3	X 10	0		5	03,04	
14	AI.6	8	3	X 10	0		5	03,04	
15	AV.14	9	3	X 10	0		5	03,04	
16	AI.4	10	3	X 10	0		5	03,04	
17	AI.3	11	3	X 10	0		5	03,04	
18	AI.11	12	2	X 1	0		5	03,04	
19	AI.53	13	2	X 1	0		5	03,04	
20	AI.54	14	2	X 1	0		5	03,04	
21	AI.55	15	2	X 1	0		5	03,04	
22		16	2	X 1	0		5	03,04	
23		17	2	X 1	0		5	03,04	
24		18	2	X 1	0		5	03,04	
25	AV.1	19	3	X 10	0		5	03,04	
26	AV.20	20	2	X 1	0		5	03,04	
27	AV.6	21	3	X 10	0		5	03,04	
28	AV.7	22	3	X 10	0		5	03,04	
29	AI.7	23	3	X 10	0		5	03,04	
30	AI.32	24	3	X 10	0		5	03,04	
31	AI.35	25	2	X 1	0		5	03,04	
32	AV.15	26	2	X 1	0		5	03,04	
33	AV.16	27	2	X 1	0		5	03,04	
34	AI.30	28	3	X 10	0		5	03,04	
35	AI.31	29	3	X 10	0		5	03,04	
36	BO.1	65		N/A			5	01,02,03	
37	BO.14	66		N/A			5	01,02,03	
38	BO.2	67		N/A			5	01,02,03	
39	BI.4	68		N/A			5	01,02,03	
40	BI.1	69		N/A			5	01,02,03	
41		70		N/A			5	01,02,03	
42		71		N/A			5	01,02,03	
43		72		N/A			5	01,02,03	
44		73		N/A			5	01,02,03	
45		74		N/A			5	01,02,03	
46		75		N/A			5	01,02,03	
47		76		N/A			5	01,02,03	
48	BV.42	77		N/A			5	01,02,03	
49	BV.43	78		N/A			5	01,02,03	
50	BO.30	79		N/A			5	01,02,03	
51	BV.46	80		N/A			5	01,02,03	
52	BV.44	81		N/A			5	01,02,03	
53		82		N/A			5	01,02,03	
54		83		N/A			5	01,02,03	
55		84		N/A			5	01,02,03	
56	AV.19	30	2	X 1	0		5	03,04	
57	SC.4	31	2	X 1	0		5	03,04	
58	SC.1	32	2	X 1	0		5	03,04	
59	SC.2	33	2	X 1	0		5	03,04	
60	SC.3	34	2	X 1	0		5	03,04	
61	AI.58	35	3	X 10	0		5	03,04	
62	AI.59	36	3	X 10	0		5	03,04	
63	AI.50	37	2	X 1	0		5	03,04	
64	AV.78	38	2	X 1	0		5	03,04	
65	AV.42	39	2	X 1	0		5	03,04	
66	AI.33	40	2	X 1	0		5	03,04	
67	AV.40	41	2	X 1	0		5	03,04	
68	AI.34	42	2	X 1	0		5	03,04	
69	AV.79	43	2	X 1	0		5	03,04	
70	AI.51	44	3	X 10	0		5	03,04	
71	AV.71	45	3	X 10	0		5	03,04	
72	AV.72	46	2	X 1	0		5	03,04	
73	AI.56	47	2	X 1	0		5	03,04	
74	AI.57	48	2	X 1	0		5	03,04	
75	AV.75	49	2	X 1	0		5	03,04	
76	AI.52	50	2	X 1	0		5	03,04	
77	AV.83	51	2	X 1	0		5	03,04	
78	AV.84	52	2	X 1	0		5	03,04	
79	AV.82	53	2	X 1	0		5	03,04	
80		85	2	X 1	0		5	01,02,03	
81		86	2	X 1	0		5	01,02,03	
82		87	2	X 1	0		5	01,02,03	
83		88	2	X 1	0		5	01,02,03	
84		89	2	X 1	0		5	01,02,03	

SAMPLE

NOTES



P.O. Box 1592, York, Pennsylvania USA 17405-1592
Tele. 800-861-1001 website: www.york.com
Copyright © by York International Corporation 2003
Form 450.20-01 (1203)
Supersedes: 450.20-01 (301)

Unit 1, Red Shute Hill, Hermitage, Newbury, Berks RG18 9QL United Kingdom
Tele: +44 (0)1635 202200 e-mail: controls.sales@uk.york.com
Subject to change without notice. Printed in USA
ALL RIGHTS RESERVED