

MVVSD1000R_-84
 MVVSD1250R_-84
 MVVSD1500R_-84
 MVVSD1750R_-84
 MVVSD2000R_-84

T = YT UNITS
 K = YK UNITS

NO	DRAWING NO	REV	DRAWING DESCRIPTION
00	1808JD00	2	MEDIUM VOLTAGE FLOOR MOUNT VFD
01	---	---	----
02	---	---	----
03	1808JD03	0	GROUNDING PROCEDURE
04	---	---	----
05	1808JD05	0	RATING SHEET
06	---	---	----
07	1808JD07	0	ONE-LINE DIAGRAM
08	---	---	----
09	---	---	----
10	1808JD10	1	THREE-LINE DIAGRAM
11	1808JD11	0	MAIN CIRCUIT
12	1808JD12	0	RECTIFIER CIRCUIT
13	---	---	----
14	---	---	----
15	1808JD15	0	CONTROL POWER AND FAN CIRCUITS

NO	DRAWING NO	REV	DRAWING DESCRIPTION
16	1808JD16	1	PCB INTERCONNECTION (1)
17	1808JD17	0	PCB INTERCONNECTION (2)
18	1808JD18	0	EXTERNAL I/O (1)
19	1808JD19	0	EXTERNAL I/O (2)
20	1808JD20	0	CONTROL CIRCUIT
21	---	---	----
22	---	---	----
23	---	---	----
24	---	---	----
25	---	---	----
26	---	---	----
27	---	---	----
28	1808JD28	1	CHILLER SYSTEM TERMINAL CONNECTIONS
29	---	---	----
30	1808JD30	0	ENCLOSURE OUTLINE
31	---	---	----

REV. LEV.	DATE	REVISION RECORD	CHG. NO.	DR.	CK.	REV. LEV.	DATE	REVISION RECORD	CHG. NO.	DR.	CK.	REV. LEV.	DATE	REVISION RECORD	CHG. NO.	DR.	CK.
6						13						20					
5						12						19					
4						11						18					
3						10						17					
2	05/22/08	REVISED		OB	AL	9						16					
1	02/05/08	REVISED		OB	AL	8						15					
0	04/20/06	FIRST ISSUE		OB	AL	7						14					

"ALL PROPRIETARY RIGHTS IN THE SUBJECT MATTER HEREOF ARE RESERVED, AND NO PERMISSION IS GRANTED TO REPRODUCE THIS PRINT IN WHOLE OR IN PART, OR DISCLOSE ANY OF THE INFORMATION UPON IT TO OTHERS WITHOUT WRITTEN RELEASE BY YORK INTERNATIONAL CORPORATION."

YORK INTERNATIONAL CORPORATION YORK, PA .17405			
DIMENSIONS ARE IN INCHES DO NOT SCALE TOLERANCES PER ENG. STD. M-282 WELDING PER ENG. STD. M-30 REF. DWG.		MEDIUM VOLTAGE VFD FLOOR MOUNT FRAME 1 4160V	
DR. NAME _____ DATE _____		SIZE D	CAGE NO _____
APPR. SCALE: _____		DRAWING NUMBER 1808JD00	
WT. = _____ LBS.		ORIG. NO. _____	SHEET 1 of 15

STANDARD PANEL GROUNDING PROCEDURES
TO BE FOLLOWED AT INSTALLATION

SCOPE

THIS DRAWING WILL DOCUMENT PROCEDURES WHICH ARE TO BE FOLLOWED BY CUSTOMER'S CONTRACTOR WHEN INSTALLING INDUSTRIAL DRIVE AND MOTOR SYSTEMS

IN ORDER TO UNDERSTAND THE REASONS FOR MANY OF THE PRACTICES THAT ARE RECOMMENDED, IT IS HELPFUL TO SEGREGATE THESE PRACTICES INTO TWO CATEGORIES AS FOLLOWS:

1) THOSE GENERALLY REFERRED TO AS EQUIPMENT GROUNDING PRACTICES WHOSE PURPOSES ARE:

- TO PROTECT AGAINST THE RISK OF ELECTRICAL SHOCK OR BURN.
- TO PROTECT THE EQUIPMENT FROM FIRE OR OTHER DAMAGE DUE TO GROUND FAULTS OR LIGHTNING STRIKES.

THESE PRACTICES WOULD TYPICALLY BE FOLLOWED BY THE CONTRACTOR IN COMPLIANCE WITH NEC OR OTHER CODE REQUIREMENTS.

2) THOSE PRACTICES WHICH MAKE THE EQUIPMENT IMMUNE TO ELECTRICAL NOISE ORIGINATING WITHIN OR OUTSIDE THE EQUIPMENT. THESE COMPLEMENT THE EQUIPMENT GROUNDING AND LEVEL WIRING PRACTICES IN PROVIDING NOISE IMMUNITY.

EQUIPMENT GROUNDING

- 1) ALL METAL BUILDING STRUCTURES SUCH AS COLUMNS, FLOOR BEAMS, ETC. SHOULD BE GROUNDED BY AN INTERCONNECTING HEAVY GROUND CABLE (5) IN ACCORDANCE WITH RECOMMENDED BUILDING PRACTICES AND LOCAL CODES.
- 2) ALL ELECTRICAL JOINTS AND CONNECTIONS TO THE BUILDING STRUCTURES SHOULD BE BRAZED OR EXOTHERMIC WELDED TO ASSURE THAT THE REQUIRED GOOD ELECTRICAL AND MECHANICAL PROPERTIES DO NOT DETERIORATE WITH THE PASSAGE OF TIME.
- 3) ALL PANELS SHOULD BE GROUNDED AT LEAST ONE POINT USING A HEAVY SAFETY CABLE (7). PANELS GREATER THAN 15 FT LONG SHOULD BE GROUNDED AT BOTH ENDS. THE GROUND CABLE NEEDS TO BE AT LEAST 1/0 AWG FOR MECHANICAL REASONS AND NEED NOT BE GREATER THAN 500 MCM. THIS CABLE IS USUALLY NON-INSULATED.
- 4) THE SAFETY GROUND CABLE (7) SHOULD BE BRAZED OR EXOTHERMIC WELDED (7A) TO A BUILDING STEEL STRUCTURE THAT IS CLOSEST TO THE PANEL, PREFERABLY WITHIN 25 FT.
- 5) THE EQUIPMENT END (7B) SHOULD BE BOLTED OR BRAZED TO A GROUND TERMINATION POINT ON THE PANEL.
- 6) THE EQUIPMENT GROUNDING TERMINAL IS A COPPER GROUND BUS OR STUB BUS BONDED TO THE PANEL ENCLOSURE USING BRAZING OR BOLTING IN SUCH MANNER THAT THE CONDUCTING PATH HAS A RESISTANCE OF 0.1 OHMS OR LESS.
- 7) THE GROUNDING CONDUCTORS MUST BE CAPABLE OF HANDLING ANTICIPATED GROUND FAULT CURRENTS.
- 8) THERE SHOULD BE A JUMPER CABLE (11) ACROSS THE GROUND BUS FLOOR SILL BETWEEN ANY SHIPPING SPLITS AND SIZED THE SAME AS THE SAFETY GROUND UNLESS OTHERWISE SPECIFIED.
- 9) THE PROTECTIVE GROUNDING DESCRIBED ABOVE FOR POWER CONVERSION AND CONTROL CABINETS IS ALSO NEEDED FOR MOTORS, TRANSFORMERS AND REACTORS. EACH OF THESE SHOULD HAVE ITS OWN GROUNDING CONDUCTOR GOING DIRECTLY TO THE BUILDING GROUND GRID.

GROUNDING PROCEDURES NEEDED TO ENSURE ELECTRICAL NOISE IMMUNITY

- 1) LEVELING BEAMS, STEEL MESH, GALVANIZED FLOOR, DECKING, ETC. SHOULD BE INSTALLED PRIOR TO PLACING THE EQUIPMENT. THESE SHOULD BE CONNECTED TO THE BUILDING GROUND SYSTEM USING A BRAZING OR EXOTHERMIC WELDING PROCESS.
- 2) GROUNDING LEVELING BEAMS ARE NOT AN ABSOLUTE NECESSITY FOR SATISFACTORY OPERATION. ON NEW CONSTRUCTION SUCH BEAMS CAN BE PROVIDED WITH LITTLE DIFFICULTY. FOR EXISTING CONSTRUCTION IT USUALLY WILL BE MORE DIFFICULT, IN WHICH CASE THE LEVELING BEAMS MAY BE DISPENSED WITH, PROVIDED OTHER GROUNDED STRUCTURES SUCH AS COLUMNS AND FLOOR BEAMS ARE WITHIN 10 FEET OF THE EQUIPMENT.
- 3) AFTER SETTING THE CONTROL PANELS IN PLACE, THE PERIPHERY OF THE CONTROL PANELS SHOULD BE SPOT WELDED TO THE STEEL CHANNELS APPROXIMATELY EVERY 18 INCHES. THIS CREATES A VERY GOOD HIGH FREQUENCY GROUND PLANE. CARE SHOULD BE TAKEN TO AVOID ELECTRONIC COMPONENT DAMAGE DURING THE WELDING PROCESS BY KEEPING THE WELDED RETURN PATH AS CLOSE AS POSSIBLE TO THE WORK POSITION. THAT IS, THE RETURN PATH SHOULD ALWAYS BE WITHIN 3 FEET OF THE ELECTRODE.
- 4) IF LEVELING BEAMS ARE NOT INSTALLED, A NUMBER OF GROUNDING CABLES (7C) SHOULD BE RUN FROM THE GROUND LUGS PROVIDED ON THE PANEL TO THE NEAREST GROUNDED COLUMN OR FLOOR BEAM, OR WIRE FLOOR MESH, ETC. THIS WILL PROVIDE THE NECESSARY HIGH FREQUENCY GROUND PLANE.

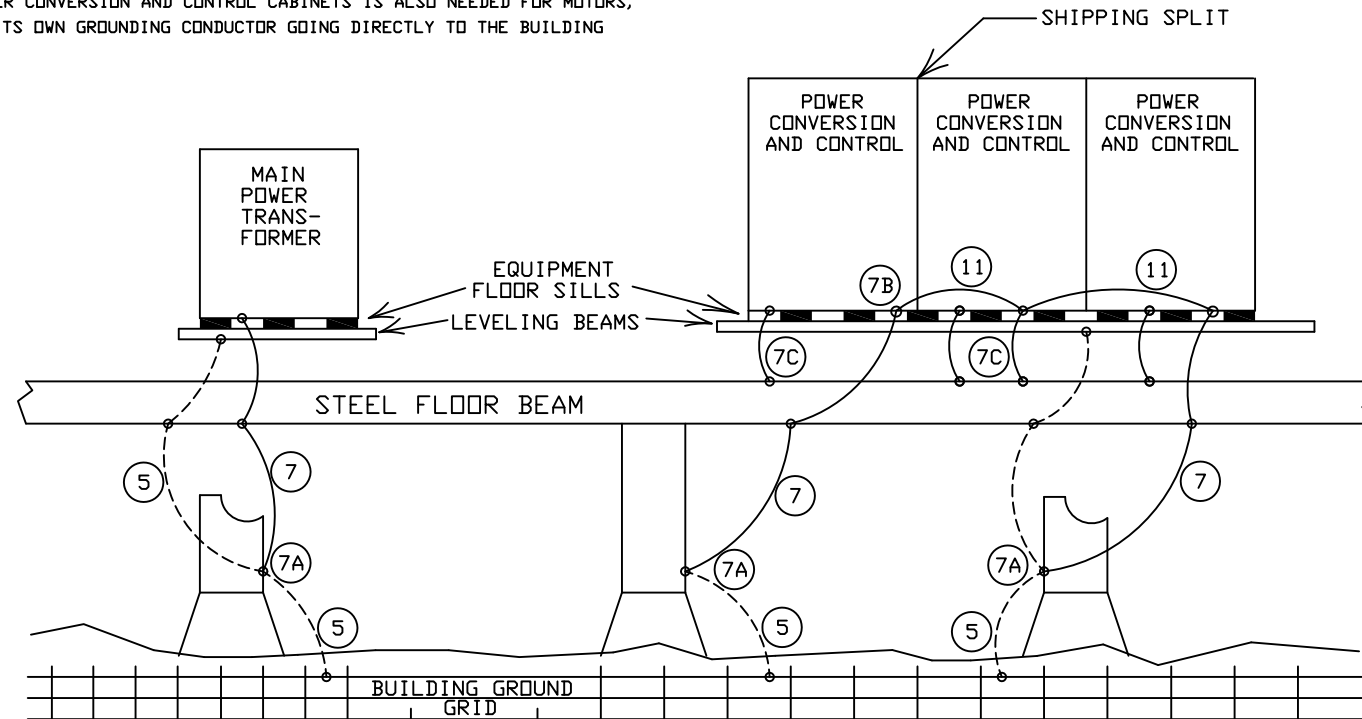

REV. LEV.	DATE	REVISION RECORD	CHG. NO.	DR.	CK.	REV. LEV.	DATE	REVISION RECORD	CHG. NO.	DR.	CK.	REV. LEV.	DATE	REVISION RECORD	CHG. NO.	DR.	CK.
6						13						20					
5						12						19					
4						11						18					
3						10						17					
2						9						16					
1						8						15					
0	04/20/06	FIRST ISSUE				7						14					

"ALL PROPRIETARY RIGHTS IN THE SUBJECT MATTER HEREOF ARE RESERVED, AND NO PERMISSION IS GRANTED TO REPRODUCE THIS PRINT IN WHOLE OR IN PART, OR DISCLOSE ANY OF THE INFORMATION UPON IT TO OTHERS WITHOUT WRITTEN RELEASE BY YORK INTERNATIONAL CORPORATION."

YORK INTERNATIONAL CORPORATION YORK, PA .17405			
DIMENSIONS ARE IN INCHES DO NOT SCALE TOLERANCES PER ENG. STD. M-282 WELDING PER ENG. STD. M-30 REF. DWG.		GROUNDING PROCEDURE	MATERIAL TYPE _____ ENG. STD. _____ PART NO. _____ CUT SIZE _____
DR. _____ APPR. _____ SCALE: _____	NAME _____ DATE _____ SIZE D	CAGE NO. _____	DRAWING NUMBER 1808JD03
WT. = _____ LBS.	ORIG. NO. _____	SHEET 2 of 15	

COMPONENT RATING			
SHEET NUMBER	COMPONENT	MVSD1000R_-84 ~ 2000R_-84	
		RATING	
5	10LA	6kV	
	10ISW1	360A, 6.6kV	
	10FU1~3	SEE TABLE A	
	10M1	360A, 6.6kV	
	10M1A	360A, 6.6kV	
	10ACL	17.9mH	
	10F4~7	2E, 4.8kV	
	10PT1~2	500VA, 4200:120V	
	10CPT	SEE TABLE A	
	10F8~10	3E, 4.8kV	
	10F12~14	SEE TABLE A	
	10F15	20A, 600Vac	
	6	HCTU,HCTW	300A:120mA
		11T1	SEE TABLE A
11R11		100k ohm, 225W	
GDI		---	
7	FUSE	SEE TABLE A	
	DIODE	2200V, 260A	
	POWER MODULE (U,V,W)	±1800Vdc, 248A	
8	15MCB1	15A, 600V	
	15V1	480V, 2a2b	
	15MS1~2	1.6~2.5A, 480V (set @ 2.3A)	
	15MOV1~3	625V, 230J	
	15FN1~2	460V, 1.2kW	
	15MCB2	240Vac, 20A, 2P	
	15F1~2	5A, 600Vac	
	PDM	---	
	15PS1	120/240:+5,+/-15,24V,80W	
	15DS1	10A, 600V	
	VX	25A, 4a4b/2a2b, 120Vac	
9	CTR	---	
	GSD	---	
	16R1,3	SEE TABLE A	
	16R2,4	SEE TABLE A	
10	MODBUS	ETHERNET/RTU (RS485)	
	IPAD	---	
	DISP	G7A	
	XIO	---	
11	BLR	24Vdc, 4a4b	
	FLT,INPC	24Vdc, 2a2b	
13	EXT	115V, 4a4b	

MODEL NUMBER	MOTOR HP	DRIVE FLA	OIL PUMP TYPE	10FU1~3 RATING	10CPT RATING	10F12~14 RATING	11T1 RATING	FUSE RATING	16R1,3 RATING	16R2,4 RATING
MVSD1000RT-84	1000	125	YT	200E, 5.5KV	4160:460V-2KVA,115V-2KVA	5A, 600V	873kVA,4160V:635V(12)	700V, 200A	32 ohm, 3W, 1%	25 ohm, 3W, 1%
MVSD1000RK-84	1000	125	YK	200E, 5.5KV	4160:460V-3KVA,115V-2KVA	7A, 600V	873kVA,4160V:635V(12)	700V, 200A	32 ohm, 3W, 1%	25 ohm, 3W, 1%
MVSD1250RT-84	1250	155	YT	200E, 5.5KV	4160:460V-2KVA,115V-2KVA	5A, 600V	1085kVA,4160V:635V(12)	700V, 200A	35 ohm, 3W, 1%	10 ohm, 3W, 1%
MVSD1250RK-84	1250	155	YK	200E, 5.5KV	4160:460V-3KVA,115V-2KVA	7A, 600V	1085kVA,4160V:635V(12)	700V, 200A	35 ohm, 3W, 1%	10 ohm, 3W, 1%
MVSD1500RT-84	1500	186	YT	250E, 5.5KV	4160:460V-2KVA,115V-2KVA	5A, 600V	1296kVA,4160V:635V(12)	700V, 200A	35 ohm, 3W, 1%	3 ohm, 3W, 1%
MVSD1500RK-84	1500	186	YK	250E, 5.5KV	4160:460V-3KVA,115V-2KVA	7A, 600V	1296kVA,4160V:635V(12)	700V, 200A	35 ohm, 3W, 1%	3 ohm, 3W, 1%
MVSD1750RT-84	1750	217	YT	300E, 5.5KV	4160:460V-2KVA,115V-2KVA	5A, 600V	1508kVA,4160V:635V(12)	700V, 250A	30 ohm, 3W, 1%	3 ohm, 3W, 1%
MVSD1750RK-84	1750	217	YK	300E, 5.5KV	4160:460V-3KVA,115V-2KVA	7A, 600V	1508kVA,4160V:635V(12)	700V, 250A	30 ohm, 3W, 1%	3 ohm, 3W, 1%
MVSD2000RT-84	2000	248	YT	350E, 5.5KV	4160:460V-2KVA,115V-2KVA	5A, 600V	1720kVA,4160V:635V(12)	700V, 250A	25 ohm, 3W, 1%	3 ohm, 3W, 1%
MVSD2000RK-84	2000	248	YK	350E, 5.5KV	4160:460V-3KVA,115V-2KVA	7A, 600V	1720kVA,4160V:635V(12)	700V, 250A	25 ohm, 3W, 1%	3 ohm, 3W, 1%

YORK INTERNATIONAL CORPORATION
YORK, PA .17405

DIMENSIONS ARE IN INCHES
DO NOT SCALE
TOLERANCES PER ENG. STD. M-282
WELDING PER ENG. STD. M-30
REF. DWG.

RATING SHEET,
COMPONENTS

MATERIAL
TYPE _____ ENG. STD. _____
PART NO. _____
CUT SIZE _____

DR. _____ DATE _____ SIZE _____ CAGE NO. _____ DRAWING NUMBER
APPR. _____ SCALE: _____ D 1808JD05

WT. = _____ LBS. ORIG. NO. _____ SHEET 3 of 15

REV. LEV.	DATE	REVISION RECORD	CHG. NO.	DR.	CK.	REV. LEV.	DATE	REVISION RECORD	CHG. NO.	DR.	CK.	REV. LEV.	DATE	REVISION RECORD	CHG. NO.	DR.	CK.
6						13						20					
5						12						19					
4						11						18					
3						10						17					
2						9						16					
1						8						15					
0	04/20/06	FIRST ISSUE				7						14					

ALL PROPRIETARY RIGHTS IN THE SUBJECT MATTER HEREOF ARE RESERVED, AND NO PERMISSION IS GRANTED TO REPRODUCE THIS PRINT IN WHOLE OR IN PART, OR DISCLOSE ANY OF THE INFORMATION UPON IT TO OTHERS WITHOUT WRITTEN RELEASE BY YORK INTERNATIONAL CORPORATION.

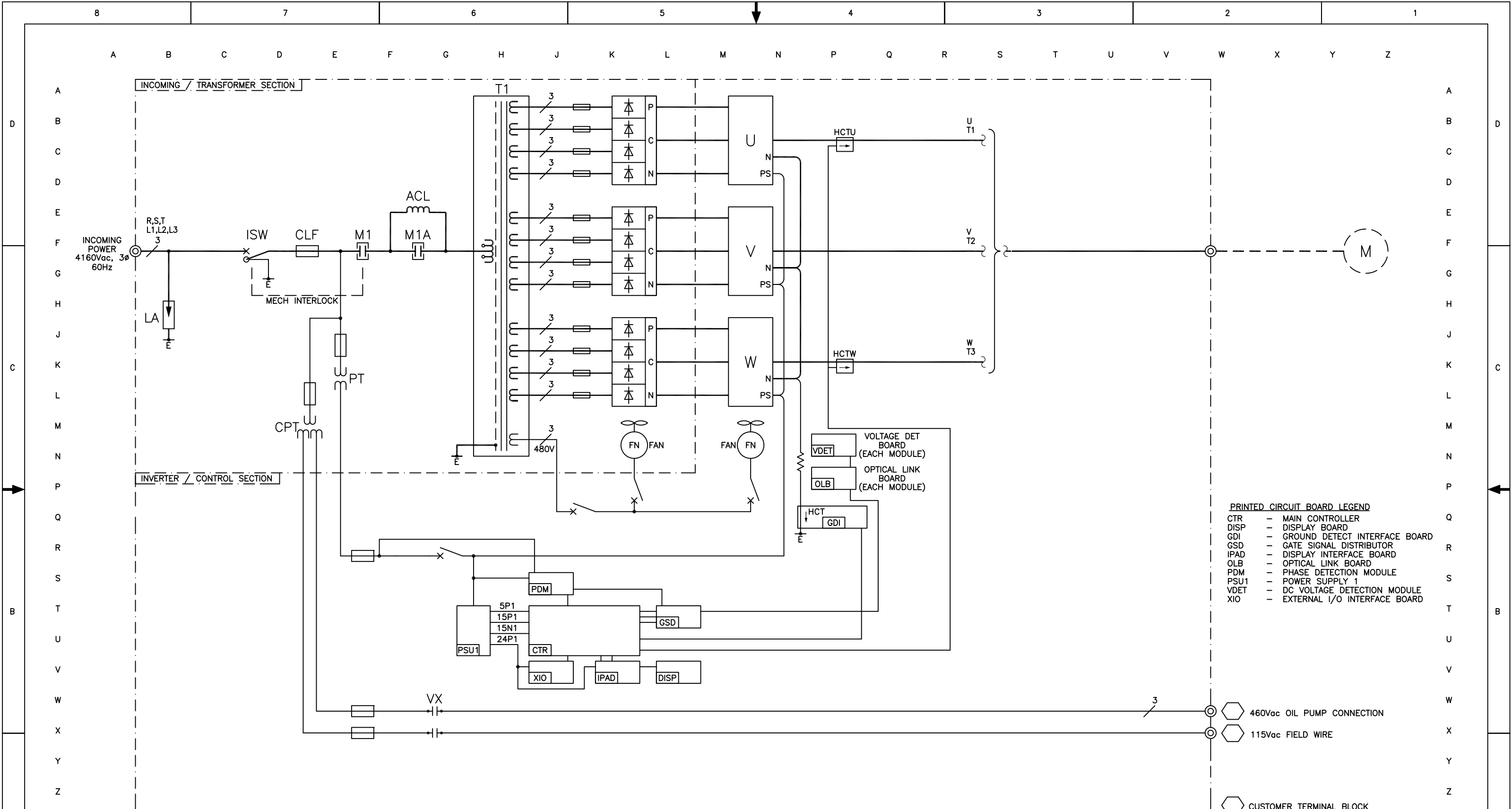

- PRINTED CIRCUIT BOARD LEGEND**
- CTR - MAIN CONTROLLER
 - DISP - DISPLAY BOARD
 - GDI - GROUND DETECT INTERFACE BOARD
 - GSD - GATE SIGNAL DISTRIBUTOR
 - IPAD - DISPLAY INTERFACE BOARD
 - OLB - OPTICAL LINK BOARD
 - PDM - PHASE DETECTION MODULE
 - PSU1 - POWER SUPPLY 1
 - VDET - DC VOLTAGE DETECTION MODULE
 - XIO - EXTERNAL I/O INTERFACE BOARD

460Vac OIL PUMP CONNECTION
 115Vac FIELD WIRE
 CUSTOMER TERMINAL BLOCK

YORK INTERNATIONAL CORPORATION
 YORK, PA . 17405

REV. LEV.	DATE	REVISION RECORD	CHG. NO.	DR.	CK.	REV. LEV.	DATE	REVISION RECORD	CHG. NO.	DR.	CK.	REV. LEV.	DATE	REVISION RECORD	CHG. NO.	DR.	CK.
6						13						20					
5						12						19					
4						11						18					
3						10						17					
2						9						16					
1						8						15					
0	04/20/06	FIRST ISSUE				7						14					

DIMENSIONS ARE IN INCHES
 DO NOT SCALE
 TOLERANCES PER ENG. STD. M-282
 WELDING PER ENG. STD. M-30
 REF. DWG.

ONE-LINE DIAGRAM

MATERIAL
 TYPE _____ ENG. STD. _____
 PART NO. _____
 CUT SIZE _____

NAME _____ DATE _____ SIZE _____ CAGE NO. _____ DRAWING NUMBER 1808JD07
 DR. APPR. _____ SCALE: _____ WT. = _____ LBS. ORG. NO. _____ SHEET 4 of 15

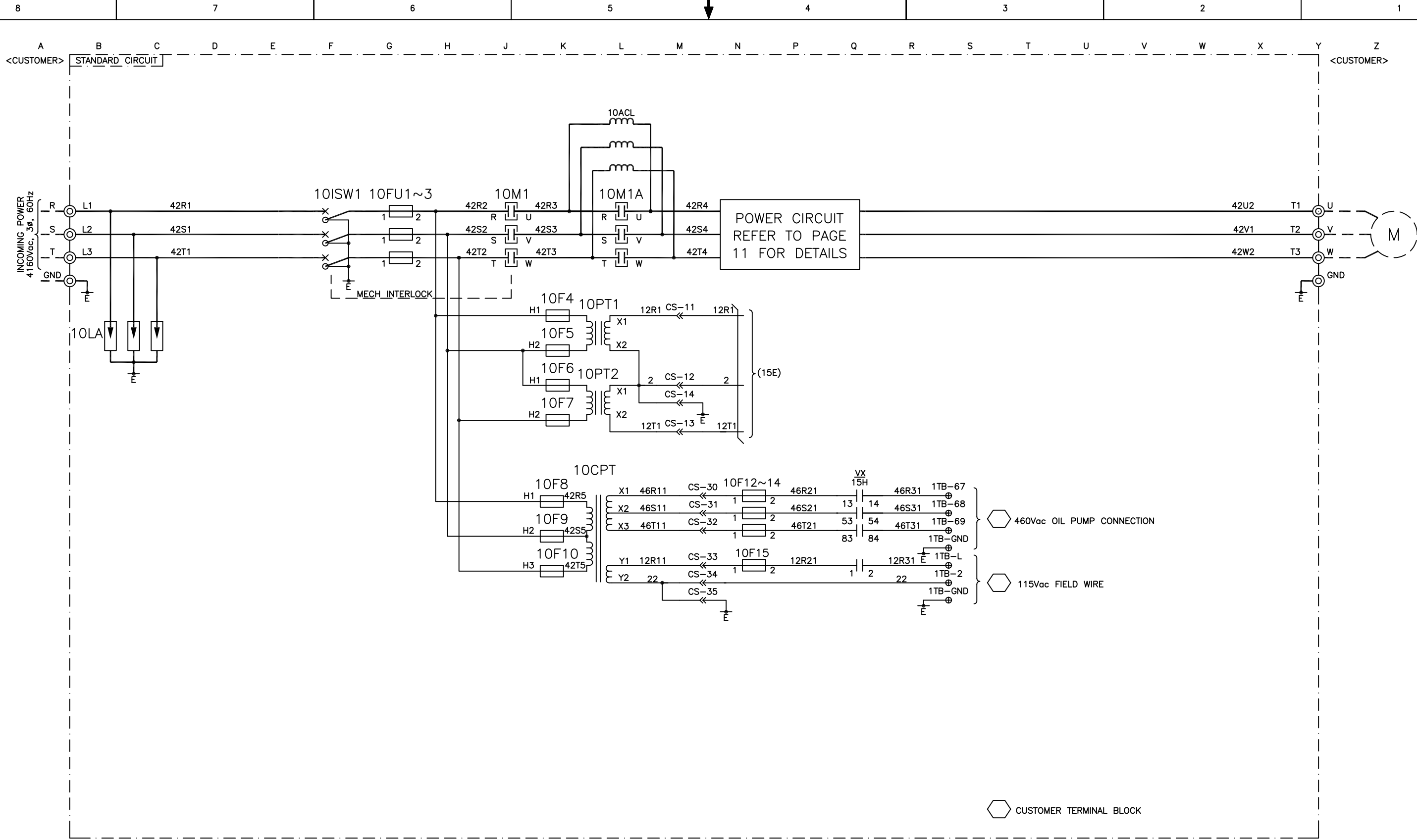

POWER CIRCUIT
REFER TO PAGE
11 FOR DETAILS

460Vac OIL PUMP CONNECTION

115Vac FIELD WIRE

CUSTOMER TERMINAL BLOCK

YORK INTERNATIONAL CORPORATION
YORK, PA . 17405

REV. LEV.	DATE	REVISION RECORD	CHG. NO.	DR.	CK.	REV. LEV.	DATE	REVISION RECORD	CHG. NO.	DR.	CK.	REV. LEV.	DATE	REVISION RECORD	CHG. NO.	DR.	CK.
6						13						20					
5						12						19					
4						11						18					
3						10						17					
2						9						16					
1	05/22/08	ADDED CS-35		OB	AL	8						15					
0	04/20/06	FIRST ISSUE		OB	AL	7						14					

ALL PROPRIETARY RIGHTS IN THE SUBJECT MATTER HEREOF ARE RESERVED, AND NO PERMISSION IS GRANTED TO REPRODUCE THIS PRINT IN WHOLE OR IN PART, OR DISCLOSE ANY OF THE INFORMATION UPON IT TO OTHERS WITHOUT WRITTEN RELEASE BY YORK INTERNATIONAL CORPORATION.

DIMENSIONS ARE IN INCHES
DO NOT SCALE
TOLERANCES PER ENG. STD. M-282
WELDING PER ENG. STD. M-30
REF. DWG.

THREE-LINE
DIAGRAM

MATERIAL
TYPE _____ ENG. STD. _____
PART NO. _____
CUT SIZE _____

DR. _____ DATE _____ SIZE D CAGE NO. _____ DRAWING NUMBER 1808JD10
APPR. _____
SCALE: _____

WT. = _____ LBS. ORIG. NO. _____ SHEET 5 of 15

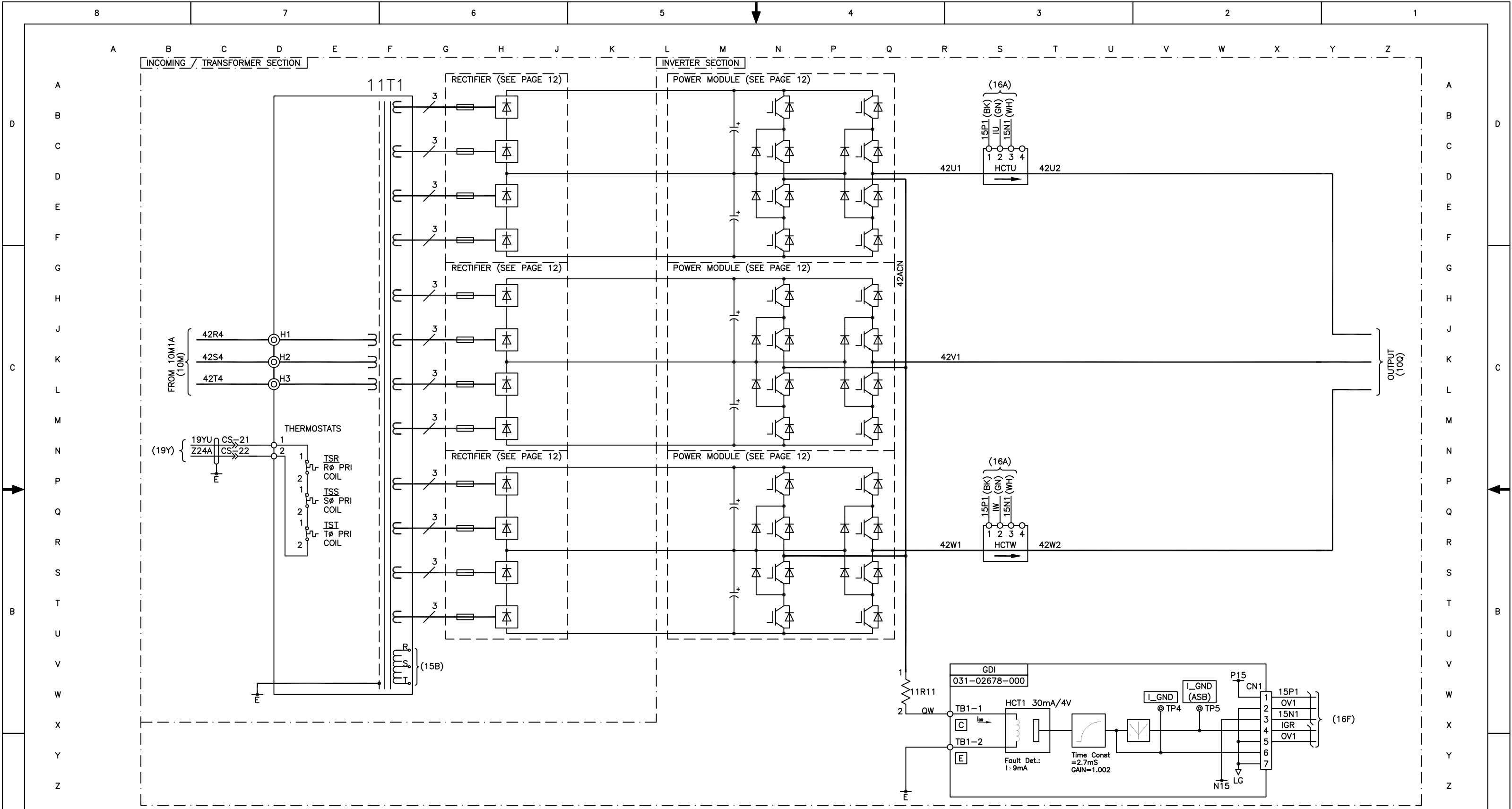

YORK INTERNATIONAL CORPORATION YORK, PA . 17405																				
REVISION RECORD						REVISION RECORD						REVISION RECORD								
REV. LEV.	DATE	CHG. NO.	DR.	CK.	REV. LEV.	DATE	CHG. NO.	DR.	CK.	REV. LEV.	DATE	CHG. NO.	DR.	CK.	REV. LEV.	DATE	CHG. NO.	DR.	CK.	
6					13					20										
5					12					19										
4					11					18										
3					10					17										
2					9					16										
1					8					15										
0	04/20/06	FIRST ISSUE			7					14										

DIMENSIONS ARE IN INCHES DO NOT SCALE TOLERANCES PER ENG. STD. M-282 WELDING PER ENG. STD. M-30 REF. DWG.												MAIN CIRCUIT						MATERIAL TYPE _____ ENG. STD. _____ PART NO. _____ CUT SIZE _____					
NAME _____ DATE _____				SIZE D				CAGE NO. _____				DRAWING NUMBER 1808JD11											
DR. APPR. _____ SCALE: _____												WT. = _____ LBS.				ORIG. NO. _____				SHEET 6 of 15			

*ALL PROPRIETARY RIGHTS
 IN THE SUBJECT MATTER
 HEREOF ARE RESERVED,
 AND NO PERMISSION IS
 GRANTED TO REPRODUCE
 THIS PRINT IN WHOLE
 OR IN PART, OR DISCLOSE
 ANY OF THE INFORMATION
 UPON IT TO OTHERS
 WITHOUT WRITTEN RELEASE
 BY YORK INTERNATIONAL
 CORPORATION.

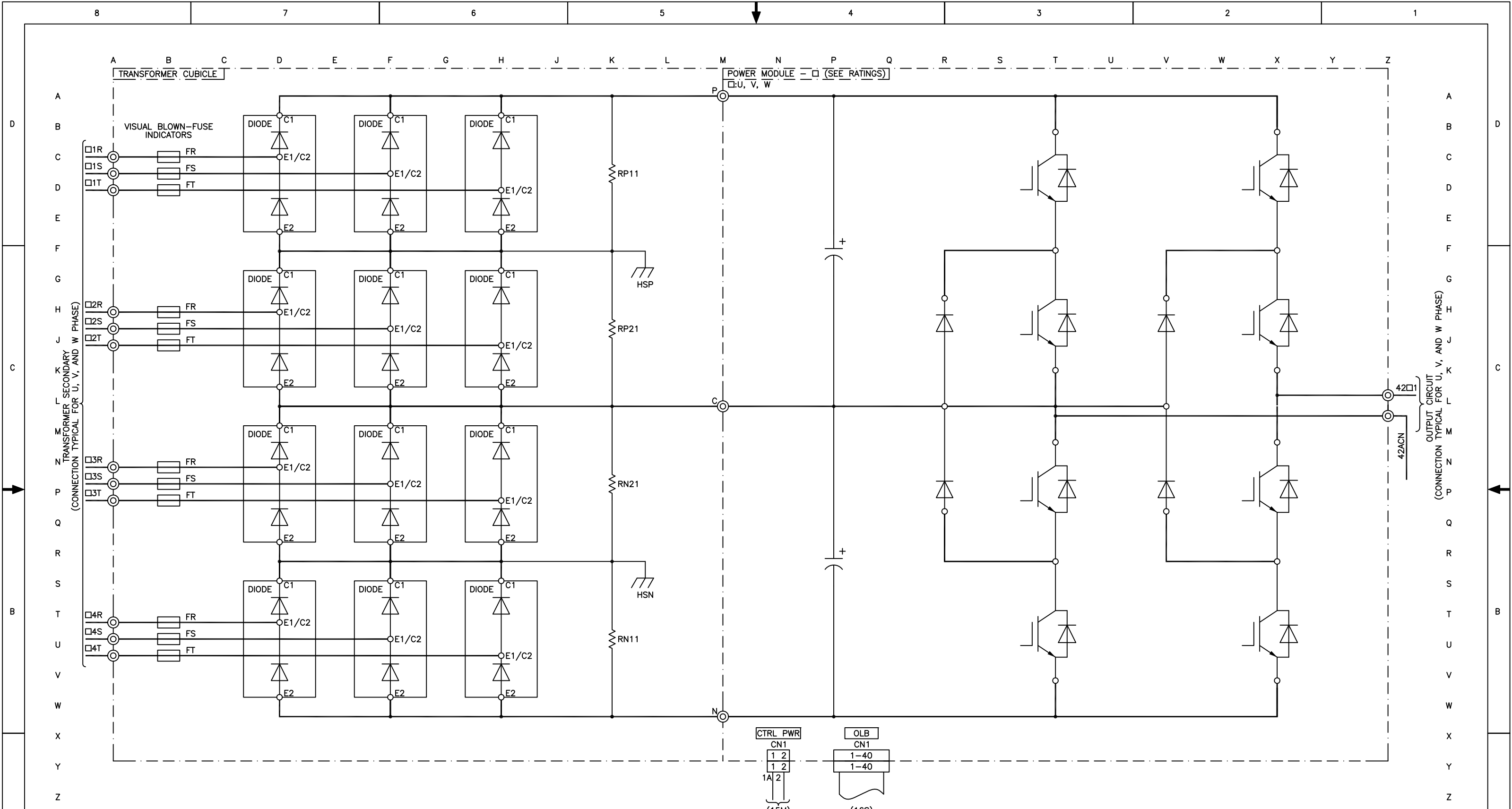

<p>YORK INTERNATIONAL CORPORATION YORK, PA . 17405</p>																																																																																																																																							
<p>REVISION RECORD</p> <table border="1"> <tr><th>REV. LEV.</th><th>DATE</th><th>CHG. NO.</th><th>DR.</th><th>CK.</th></tr> <tr><td>6</td><td></td><td></td><td></td><td></td></tr> <tr><td>5</td><td></td><td></td><td></td><td></td></tr> <tr><td>4</td><td></td><td></td><td></td><td></td></tr> <tr><td>3</td><td></td><td></td><td></td><td></td></tr> <tr><td>2</td><td></td><td></td><td></td><td></td></tr> <tr><td>1</td><td></td><td></td><td></td><td></td></tr> <tr><td>0</td><td>04/20/06</td><td></td><td>OB</td><td>AL</td></tr> </table>				REV. LEV.	DATE	CHG. NO.	DR.	CK.	6					5					4					3					2					1					0	04/20/06		OB	AL	<p>REVISION RECORD</p> <table border="1"> <tr><th>REV. LEV.</th><th>DATE</th><th>CHG. NO.</th><th>DR.</th><th>CK.</th></tr> <tr><td>13</td><td></td><td></td><td></td><td></td></tr> <tr><td>12</td><td></td><td></td><td></td><td></td></tr> <tr><td>11</td><td></td><td></td><td></td><td></td></tr> <tr><td>10</td><td></td><td></td><td></td><td></td></tr> <tr><td>9</td><td></td><td></td><td></td><td></td></tr> <tr><td>8</td><td></td><td></td><td></td><td></td></tr> <tr><td>7</td><td></td><td></td><td></td><td></td></tr> </table>				REV. LEV.	DATE	CHG. NO.	DR.	CK.	13					12					11					10					9					8					7					<p>REVISION RECORD</p> <table border="1"> <tr><th>REV. LEV.</th><th>DATE</th><th>CHG. NO.</th><th>DR.</th><th>CK.</th></tr> <tr><td>20</td><td></td><td></td><td></td><td></td></tr> <tr><td>19</td><td></td><td></td><td></td><td></td></tr> <tr><td>18</td><td></td><td></td><td></td><td></td></tr> <tr><td>17</td><td></td><td></td><td></td><td></td></tr> <tr><td>16</td><td></td><td></td><td></td><td></td></tr> <tr><td>15</td><td></td><td></td><td></td><td></td></tr> <tr><td>14</td><td></td><td></td><td></td><td></td></tr> </table>				REV. LEV.	DATE	CHG. NO.	DR.	CK.	20					19					18					17					16					15					14					<p>RECTIFIER CKT. (ONE PHASE)</p> <p>MATERIAL TYPE _____ ENG. STD. _____</p> <p>PART NO. _____</p> <p>CUT SIZE _____</p> <p>DRAWING NUMBER: 1808JD12</p> <p>DR. APPR. _____</p> <p>SCALE: _____</p> <p>WT. = _____ LBS. ORG. NO. _____ SHEET 7 of 15</p>			
REV. LEV.	DATE	CHG. NO.	DR.	CK.																																																																																																																																			
6																																																																																																																																							
5																																																																																																																																							
4																																																																																																																																							
3																																																																																																																																							
2																																																																																																																																							
1																																																																																																																																							
0	04/20/06		OB	AL																																																																																																																																			
REV. LEV.	DATE	CHG. NO.	DR.	CK.																																																																																																																																			
13																																																																																																																																							
12																																																																																																																																							
11																																																																																																																																							
10																																																																																																																																							
9																																																																																																																																							
8																																																																																																																																							
7																																																																																																																																							
REV. LEV.	DATE	CHG. NO.	DR.	CK.																																																																																																																																			
20																																																																																																																																							
19																																																																																																																																							
18																																																																																																																																							
17																																																																																																																																							
16																																																																																																																																							
15																																																																																																																																							
14																																																																																																																																							

"ALL PROPRIETARY RIGHTS IN THE SUBJECT MATTER HEREOF ARE RESERVED, AND NO PERMISSION IS GRANTED TO REPRODUCE THIS PRINT IN WHOLE OR IN PART, OR DISCLOSE ANY OF THE INFORMATION UPON IT TO OTHERS WITHOUT WRITTEN RELEASE BY YORK INTERNATIONAL CORPORATION."

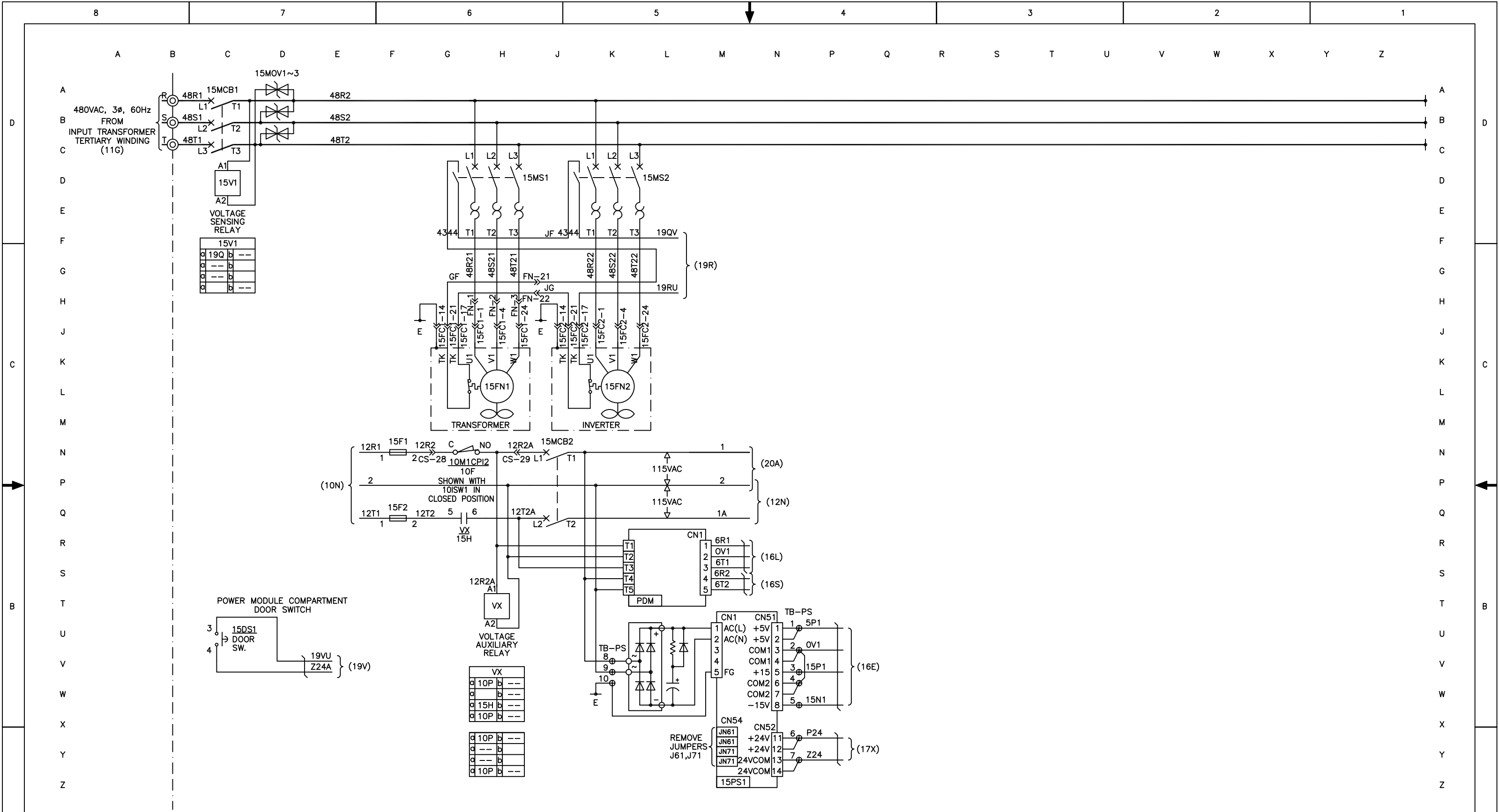

YORK INTERNATIONAL CORPORATION
YORK, PA .17405

DIMENSIONS ARE IN INCHES DO NOT SCALE TOLERANCES PER ENG. STD. M-282 WELDING PER ENG. STD. M-30 REF. DWG.		CONTROL POWER AND FANS CIRCUIT		MATERIAL TYPE _____ ENG. STD. _____ PART NO. _____ CUT SIZE _____	
DR. _____	DATE _____	SIZE D	CAGE NO. _____	DRAWING NUMBER 1808JD15	
SCALE: _____		WT. = _____ LBS.	ORIG. NO. _____	SHEET 8 of 15	

REV. LEV.	DATE	REVISION RECORD	CHG. NO.	DR.	CK.	REV. LEV.	DATE	REVISION RECORD	CHG. NO.	DR.	CK.	REV. LEV.	DATE	REVISION RECORD	CHG. NO.	DR.	CK.
6						13						20					
5						12						19					
4						11						18					
3						10						17					
2						9						16					
1						8						15					
0	04/20/06	FIRST ISSUE		OB	AL	7						14					

*ALL PROPRIETARY RIGHTS IN THE SUBJECT MATTER HEREOF ARE RESERVED, AND NO PERMISSION IS GRANTED TO REPRODUCE THIS PRINT IN WHOLE OR IN PART, OR DISCLOSE ANY OF THE INFORMATION UPON IT TO OTHERS WITHOUT WRITTEN RELEASE BY YORK INTERNATIONAL CORPORATION.

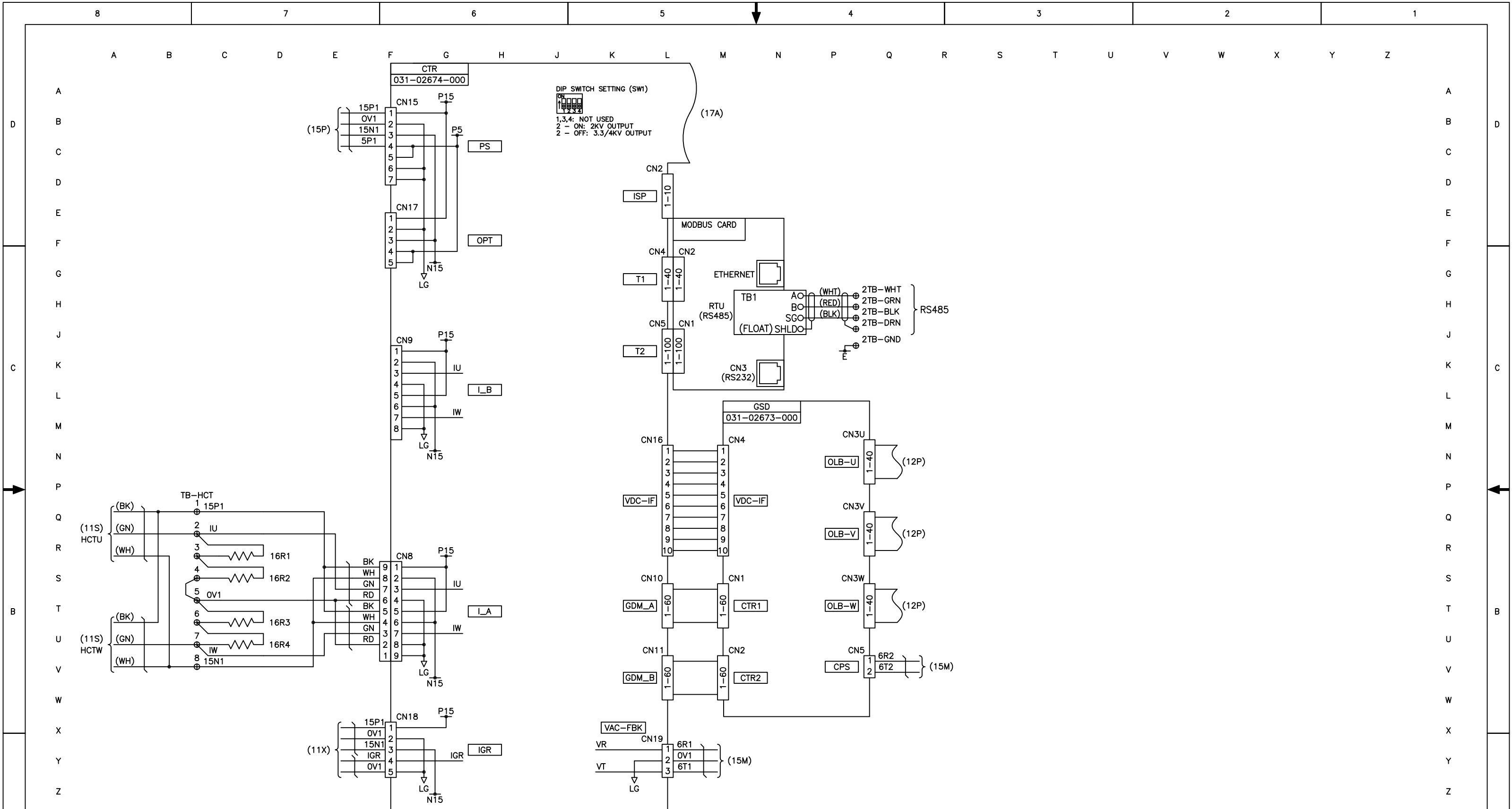

YORK INTERNATIONAL CORPORATION
 YORK, PA . 17405

PCB (1)
INTERCONNECTION

MATERIAL
 TYPE _____ ENG. STD. _____
 PART NO. _____
 CUT SIZE _____

DR. _____	DATE _____	SIZE D	CAGE NO. _____	DRAWING NUMBER 1808JD16
APPR. _____				
SCALE: _____				

WT. = _____ LBS. ORIG. NO. _____ SHEET 9 of 15

REV. LEV.	DATE	REVISION RECORD	CHG. NO.	DR.	CK.	REV. LEV.	DATE	REVISION RECORD	CHG. NO.	DR.	CK.	REV. LEV.	DATE	REVISION RECORD	CHG. NO.	DR.	CK.
6						13						20					
5						12						19					
4						11						18					
3						10						17					
2						9						16					
1	02/05/08	REMOVED 2TB JUMPER & RES		OB	AL	8						15					
0	04/28/06	FIRST ISSUE		OB	AL	7						14					

ALL PROPRIETARY RIGHTS IN THE SUBJECT MATTER HEREOF ARE RESERVED, AND NO PERMISSION IS GRANTED TO REPRODUCE THIS PRINT IN WHOLE OR IN PART, OR DISCLOSE ANY OF THE INFORMATION UPON IT TO OTHERS WITHOUT WRITTEN RELEASE BY YORK INTERNATIONAL CORPORATION.

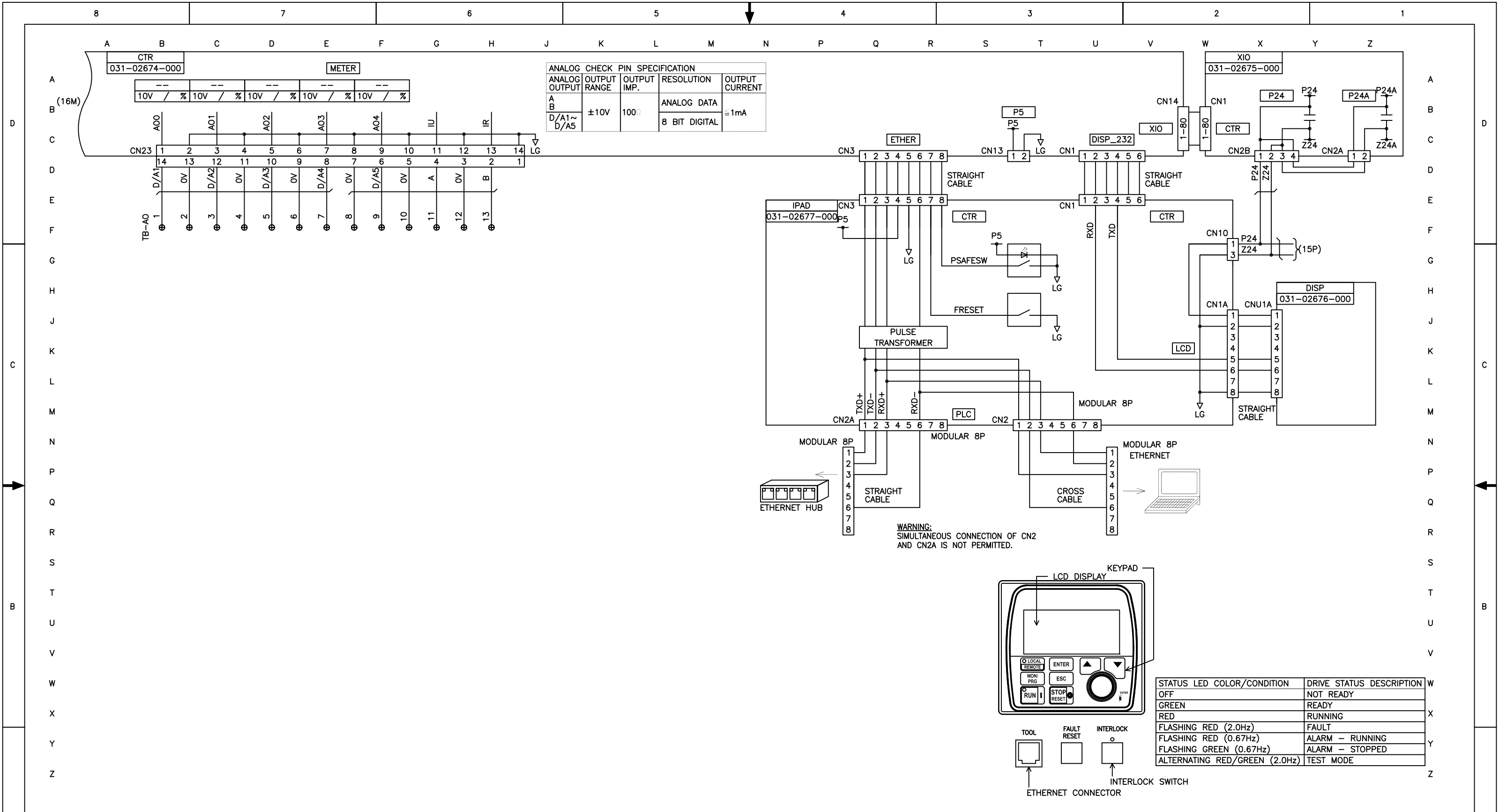

ANALOG CHECK PIN SPECIFICATION

ANALOG OUTPUT	OUTPUT RANGE	OUTPUT IMP.	RESOLUTION	OUTPUT CURRENT
A	±10V	100Ω	ANALOG DATA	≈1mA
B			8 BIT DIGITAL	

STATUS LED COLOR/CONDITION	DRIVE STATUS DESCRIPTION
OFF	NOT READY
GREEN	READY
RED	RUNNING
FLASHING RED (2.0Hz)	FAULT
FLASHING RED (0.67Hz)	ALARM - RUNNING
FLASHING GREEN (0.67Hz)	ALARM - STOPPED
ALTERNATING RED/GREEN (2.0Hz)	TEST MODE

REV. LEV.	DATE	CHG. NO.	DR.	CK.	REV. LEV.	DATE	CHG. NO.	DR.	CK.	REV. LEV.	DATE	CHG. NO.	DR.	CK.
6					13					20				
5					12					19				
4					11					18				
3					10					17				
2					9					16				
1					8					15				
0	04/20/06		OB	AL	7					14				

YORK INTERNATIONAL CORPORATION
YORK, PA . 17405

**PCB (2)
INTERCONNECTION**

MATERIAL
TYPE _____ ENG. STD. _____
PART NO. _____
CUT SIZE _____

DR. _____ DATE _____ SIZE D CAGE NO. _____ DRAWING NUMBER 1808JD17
APPR. _____ SCALE: _____ WT. = _____ LBS. ORIG. NO. _____ SHEET 10 of 15

ALL PROPRIETARY RIGHTS IN THE SUBJECT MATTER HEREOF ARE RESERVED, AND NO PERMISSION IS GRANTED TO REPRODUCE THIS PRINT IN WHOLE OR IN PART, OR DISCLOSE ANY OF THE INFORMATION UPON IT TO OTHERS WITHOUT WRITTEN RELEASE BY YORK INTERNATIONAL CORPORATION.

XIO JUMPER SETTINGS			
JUMPER	EXPLANATION	SILKSCREEN	SETTING
JP3	Pulse Generator (PG) power supply level selection. "P15" = +15VDC power supply "P5" = +5VDC power supply	[P15]	1-2
		[P5]	2-3
		[PT]	2-3
JP4	Motor temperature sensor type selection. External transducer required when using 100 ohm sensor. "PT" = 1k ohm platinum motor temperature sensor "RTD" = 100 ohm platinum motor temperature sensor	[PT]	2-3
		[RTD]	1-2

FLT		INPC		BLR	
a	20Y	b	--	a	20D
b	--	b	--	b	20C
c	--	a	--	a	20C
d	--	b	--	b	--

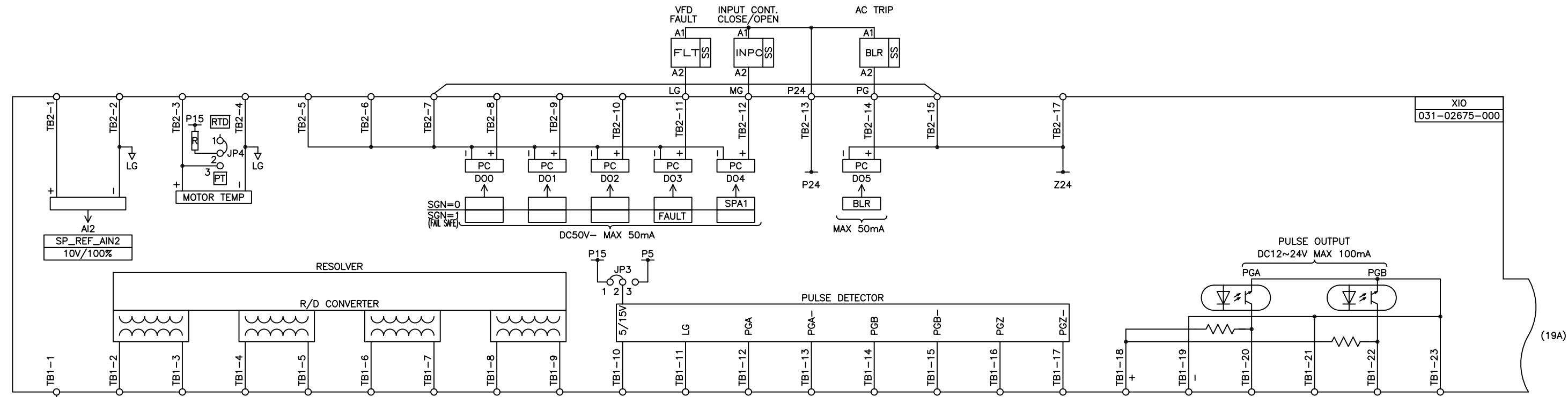

YORK INTERNATIONAL CORPORATION
YORK, PA . 17405

REV. LEV.	DATE	REVISION RECORD	CHG. NO.	DR.	CK.	REV. LEV.	DATE	REVISION RECORD	CHG. NO.	DR.	CK.	REV. LEV.	DATE	REVISION RECORD	CHG. NO.	DR.	CK.
6						13						20					
5						12						19					
4						11						18					
3						10						17					
2						9						16					
1						8						15					
0	04/20/06	FIRST ISSUE		OB	AL	7						14					

ALL PROPRIETARY RIGHTS IN THE SUBJECT MATTER HEREOF ARE RESERVED, AND NO PERMISSION IS GRANTED TO REPRODUCE THIS PRINT IN WHOLE OR IN PART, OR DISCLOSE ANY OF THE INFORMATION UPON IT TO OTHERS WITHOUT WRITTEN RELEASE BY YORK INTERNATIONAL CORPORATION.

DIMENSIONS ARE IN INCHES DO NOT SCALE TOLERANCES PER ENG. STD. M-282 WELDING PER ENG. STD. M-30 REF. DWG.		EXTERNAL I/O (1)		MATERIAL TYPE _____ ENG. STD. _____ PART NO. _____ CUT SIZE _____	
DR. _____	DATE _____	SIZE D	CAGE NO. _____	DRAWING NUMBER 1808JD18	
APPR. _____	SCALE: _____	WT. = _____ LBS.	ORIG. NO. _____	SHEET 11 of 15	

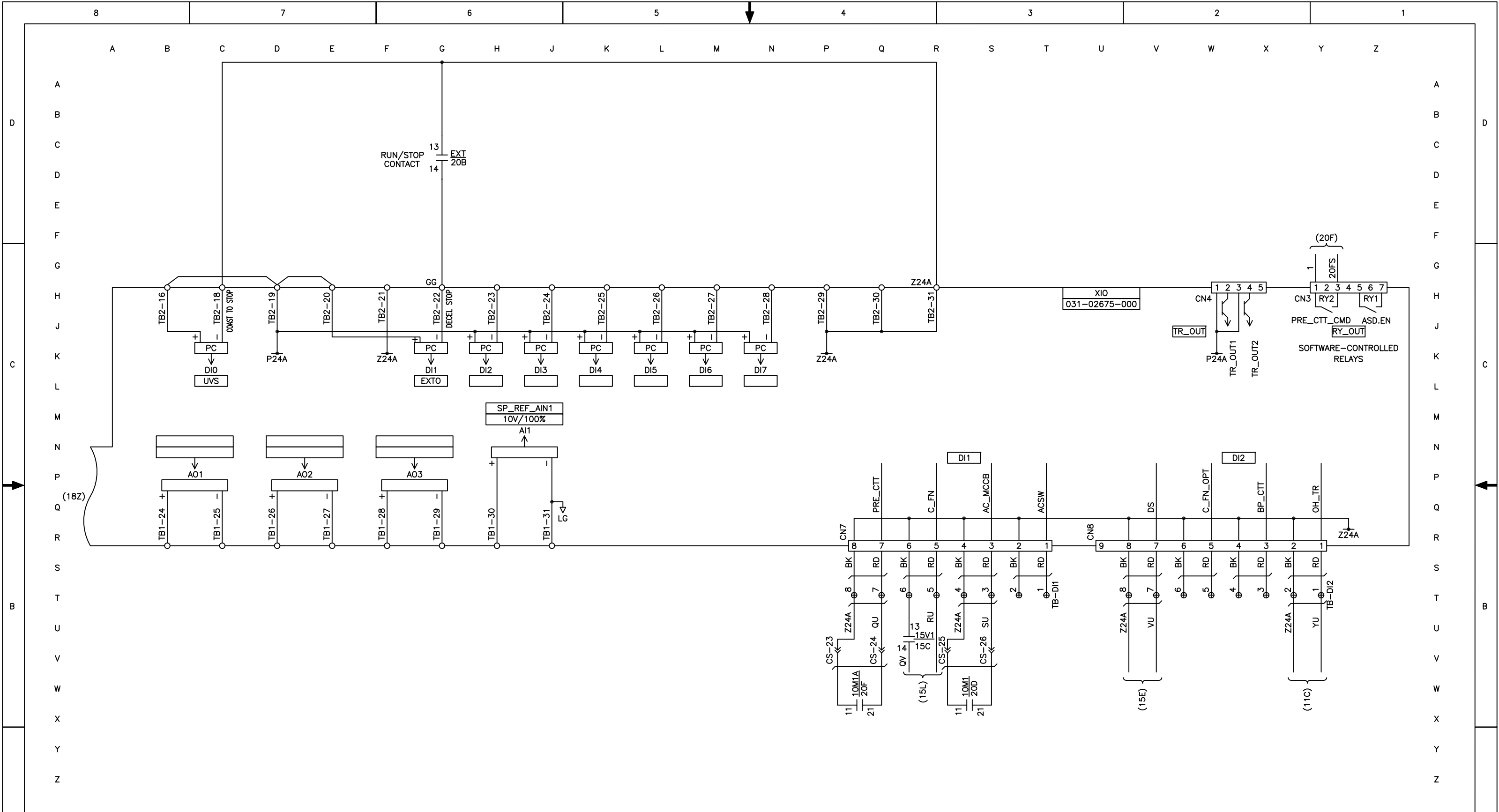

YORK INTERNATIONAL CORPORATION YORK, PA .17405											
DIMENSIONS ARE IN INCHES DO NOT SCALE TOLERANCES PER ENG. STD. M-282 WELDING PER ENG. STD. M-30 REF. DWG.				EXTERNAL I/O (2)				MATERIAL TYPE _____ ENG. STD. _____ PART NO. _____ CUT SIZE _____			
DR. _____		DATE _____		SIZE D		CAGE NO _____		DRAWING NUMBER 1808JD19			
APPR. _____		SCALE _____		WT. = _____ LBS.		ORIG. NO. _____		SHEET 12 of 15			
REVISION RECORD REV. LEV. DATE CHG. NO. DR. CK. 6 5 4 3 2 1 0 04/20/06 FIRST ISSUE OB AL			REVISION RECORD REV. LEV. DATE CHG. NO. DR. CK. 13 12 11 10 9 8 7			REVISION RECORD REV. LEV. DATE CHG. NO. DR. CK. 20 19 18 17 16 15 14			*ALL PROPRIETARY RIGHTS IN THE SUBJECT MATTER HEREOF ARE RESERVED, AND NO PERMISSION IS GRANTED TO REPRODUCE THIS PRINT IN WHOLE OR IN PART, OR DISCLOSE ANY OF THE INFORMATION UPON IT TO OTHERS WITHOUT WRITTEN RELEASE BY YORK INTERNATIONAL CORPORATION*.		

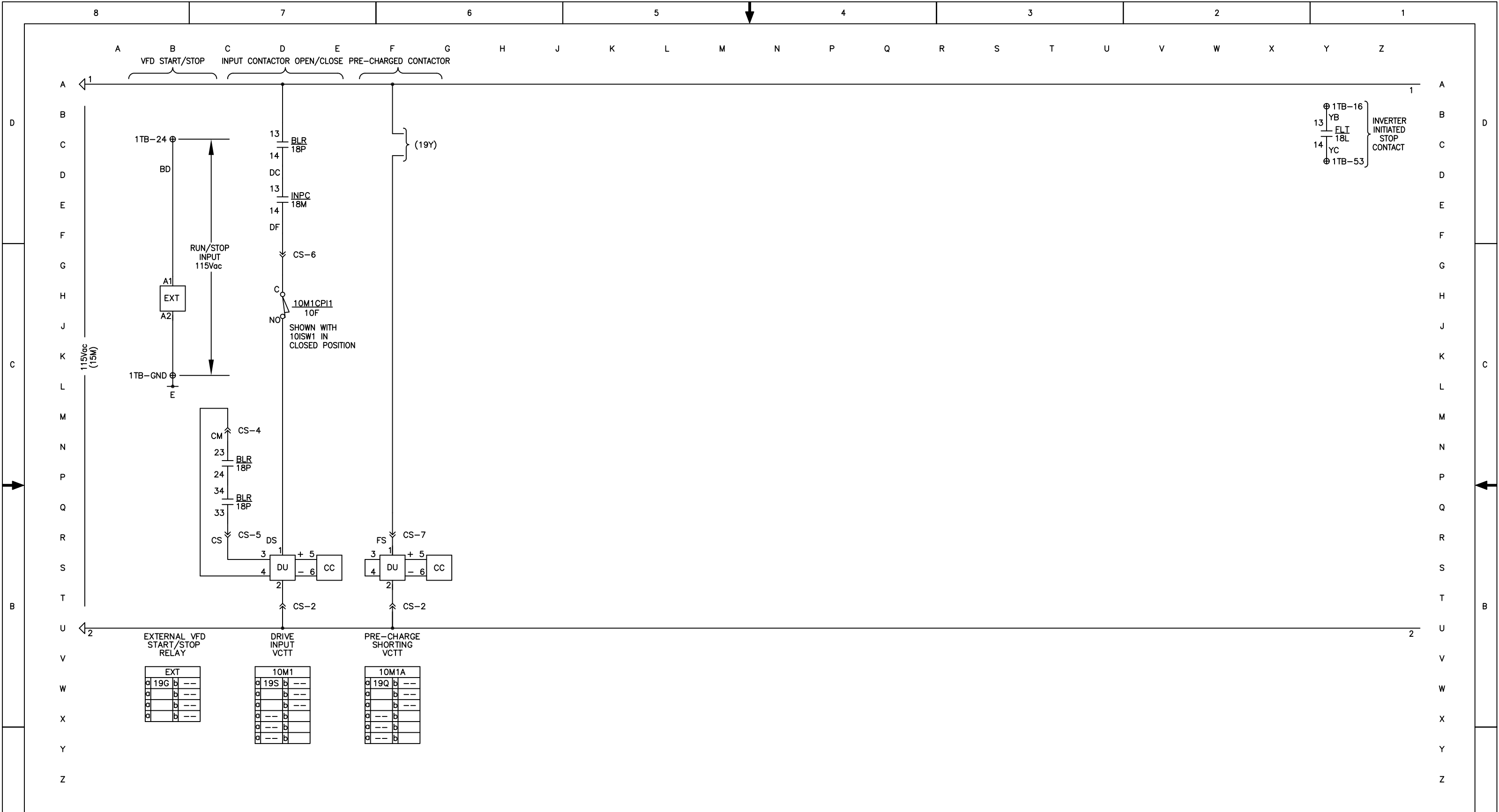

EXTERNAL VFD START/STOP RELAY		DRIVE INPUT VCTT		PRE-CHARGE SHORTING VCTT	
EXT	10M1	10M1A	EXT	10M1	10M1A
a 19G	b ---	a 19S	b ---	a 19Q	b ---
a ---	b ---	a ---	b ---	a ---	b ---
a ---	b ---	a ---	b ---	a ---	b ---
a ---	b ---	a ---	b ---	a ---	b ---

YORK INTERNATIONAL CORPORATION
YORK, PA . 17405

DIMENSIONS ARE IN INCHES DO NOT SCALE TOLERANCES PER ENG. STD. M-282 WELDING PER ENG. STD. M-30 REF. DWG.		CONTROL CIRCUIT		MATERIAL TYPE _____ ENG. STD. _____	
DR. _____ DATE _____		SIZE D	CAGE NO	DRAWING NUMBER 1808JD20	
APPR. _____ SCALE: _____		WT. = _____ LBS.	ORIG. NO.	SHEET 13 of 15	

REV. LEV.	DATE	REVISION RECORD	CHG. NO.	DR.	CK.	REV. LEV.	DATE	REVISION RECORD	CHG. NO.	DR.	CK.	REV. LEV.	DATE	REVISION RECORD	CHG. NO.	DR.	CK.
6						13						20					
5						12						19					
4						11						18					
3						10						17					
2						9						16					
1						8						15					
0	04/20/06	FIRST ISSUE		OB	AL	7						14					

ALL PROPRIETARY RIGHTS IN THE SUBJECT MATTER HEREOF ARE RESERVED, AND NO PERMISSION IS GRANTED TO REPRODUCE THIS PRINT IN WHOLE OR IN PART, OR DISCLOSE ANY OF THE INFORMATION UPON IT TO OTHERS WITHOUT WRITTEN RELEASE BY YORK INTERNATIONAL CORPORATION.

CHILLER SYSTEM INTERFACE

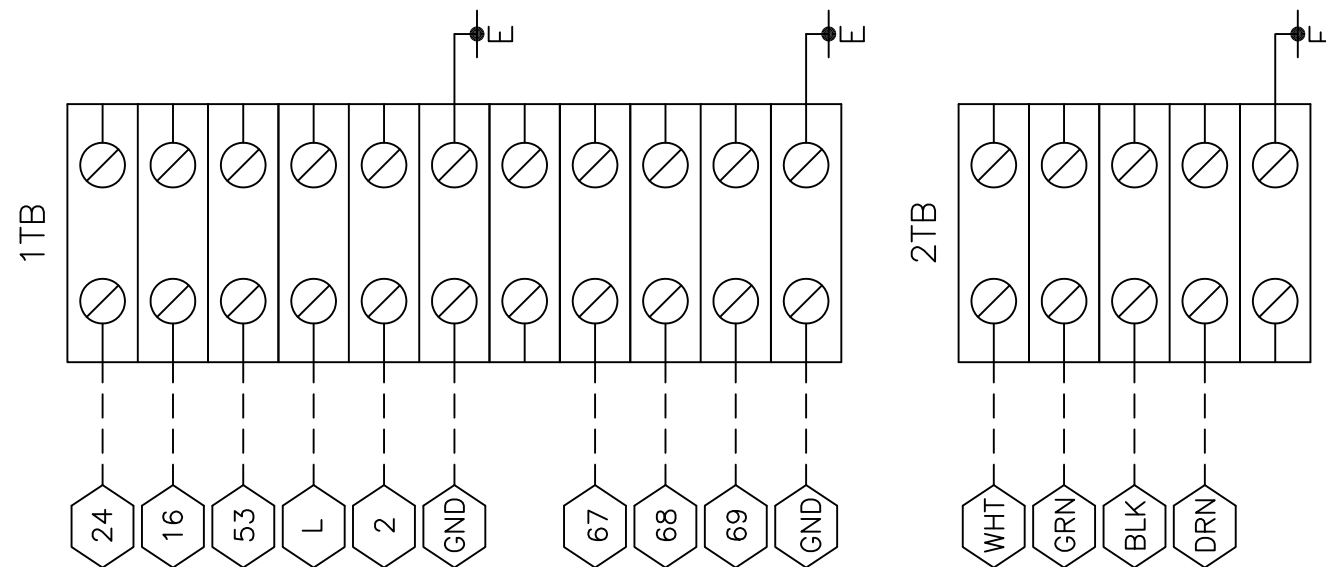

CUSTOMER TERMINAL BLOCK

REV. LEV.	DATE	REVISION RECORD	CHG. NO.	DR.	CK.	REV. LEV.	DATE	REVISION RECORD	CHG. NO.	DR.	CK.	REV. LEV.	DATE	REVISION RECORD	CHG. NO.	DR.	CK.
6						13						20					
5						12						19					
4						11						18					
3						10						17					
2						9						16					
1	02/15/08	REMOVED 2TB JUMPER		OB	AL	8						15					
0	04/20/06	FIRST ISSUE		OB	AL	7						14					

*ALL PROPRIETARY RIGHTS IN THE SUBJECT MATTER HEREOF ARE RESERVED, AND NO PERMISSION IS GRANTED TO REPRODUCE THIS PRINT IN WHOLE OR IN PART, OR DISCLOSE ANY OF THE INFORMATION UPON IT TO OTHERS WITHOUT WRITTEN RELEASE BY YORK INTERNATIONAL CORPORATION.

YORK INTERNATIONAL CORPORATION YORK, PA . 17405			
DIMENSIONS ARE IN INCHES DO NOT SCALE TOLERANCES PER ENG. STD. M-282 WELDING PER ENG. STD. M-30 REF. DWG.	CHILLER SYSTEM TERMINAL CONNECTIONS	MATERIAL TYPE _____ ENG. STD. _____ PART NO. _____ CUT SIZE _____	
DR. _____ APPR. _____ SCALE: _____	NAME _____ DATE _____ SIZE D	CAGE NO. _____ ORIG. NO. _____	DRAWING NUMBER 1808JD28 SHEET 14 of 15
WT. = _____ LBS.		SHEET 14 of 15	

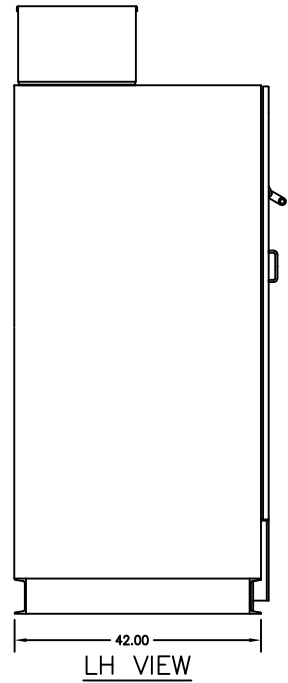
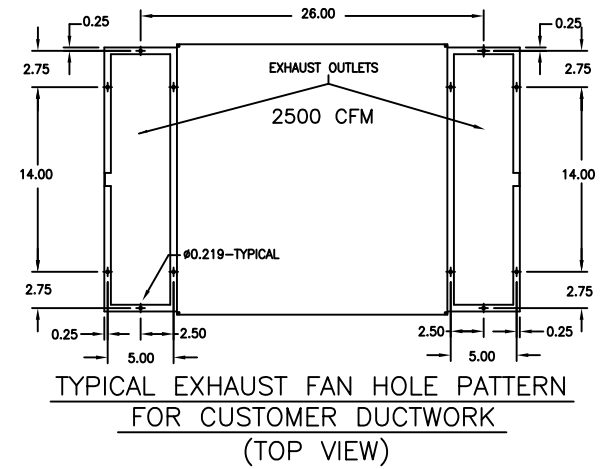
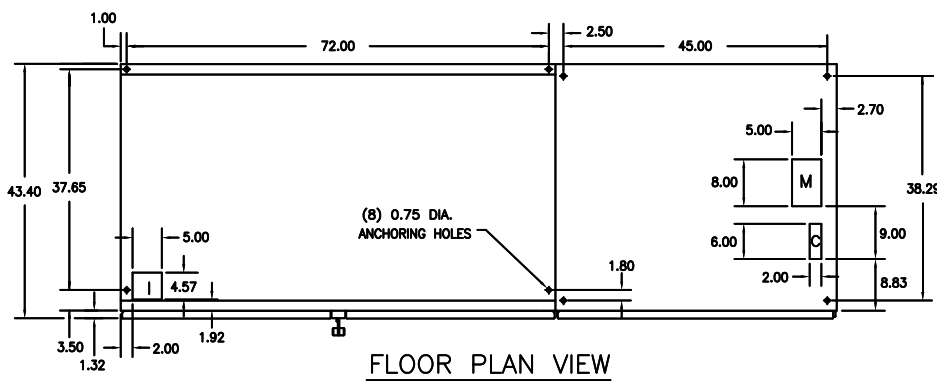
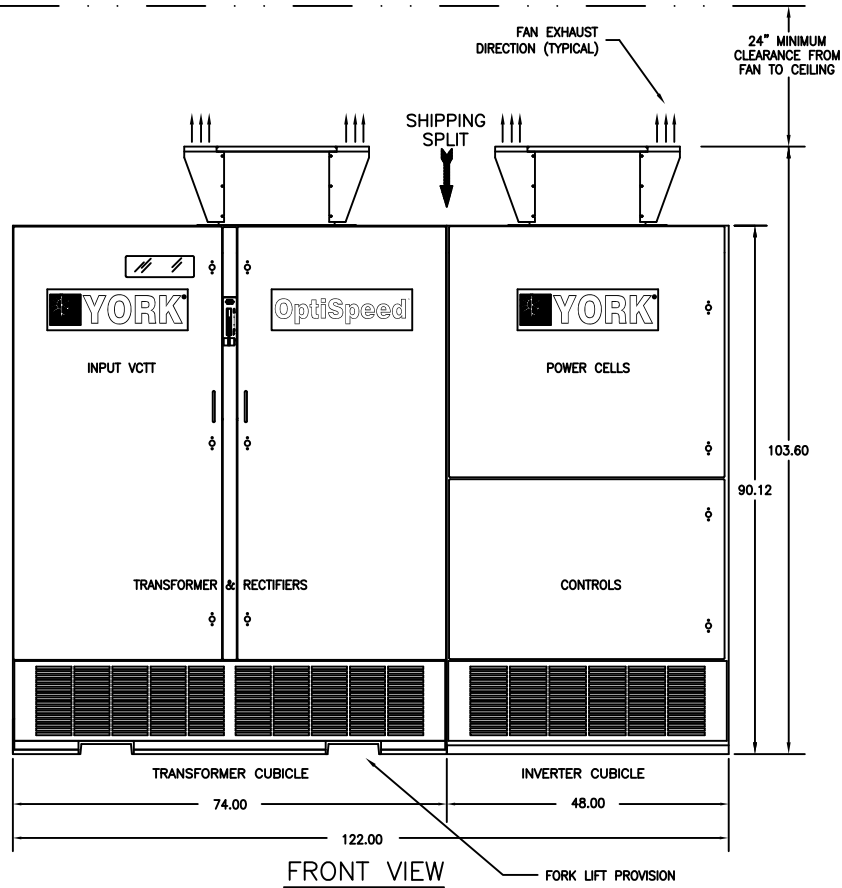
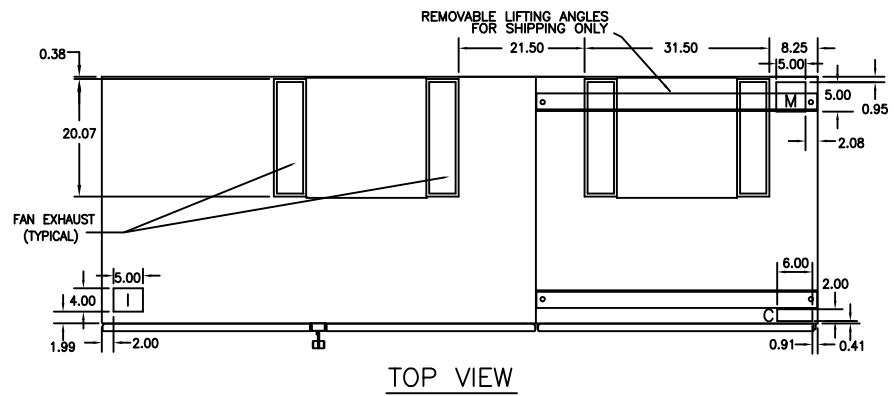

CABLE TERMINATIONS			
ENTRY	INCOMING CABLES	MOTOR LEADS	CONTROL WIRE
TOP	I	M	C
BOTTOM	I	M	C

INCOMING TERMINATIONS USE NEMA 4-HOLE PATTERN
MOTOR TERMINATIONS USE NEMA 4-HOLE PATTERN

- NOTES
- ENCLOSURE TYPE: NEMA 1 W/GASKETED DOORS
 - ALL WEIGHTS ARE APPROXIMATE
 - ALL DIMS ARE IN INCHES
 - POWER CELLS NEED TO BE REMOVED FOR ACCESS

	1000HP	1250HP	1500HP	1750HP	2000HP
TRANSFORMER CUBICLE	6,500 lbs	7,700 lbs	8,500 lbs	9,400 lbs	10,000 lbs
INVERTER CUBICLE	2,500 lbs	2,500 lbs	2,500 lbs	2,500 lbs	2,500 lbs

YORK INTERNATIONAL CORPORATION
YORK, PA . 17405

DIMENSIONS ARE IN INCHES DO NOT SCALE TOLERANCES PER ENG. STD. M-282 WELDING PER ENG. STD. M-30 REF. DWG.		OUTLINE ENCLOSURE		MATERIAL TYPE _____ ENG. STD. _____ PART NO. _____ CUT SIZE _____	
DR. _____	DATE _____	SIZE D	CAGE NO _____	DRAWING NUMBER 1808JD30	
APPR. _____	SCALE _____	WT. = _____ LBS.	ORIG. NO. _____	SHEET 15 of 15	

REV. LEV.	DATE	REVISION RECORD	CHG. NO.	DR.	CK.	REV. LEV.	DATE	REVISION RECORD	CHG. NO.	DR.	CK.	REV. LEV.	DATE	REVISION RECORD	CHG. NO.	DR.	CK.
6						13						20					
5						12						19					
4						11						18					
3						10						17					
2						9						16					
1						8						15					
0	04/28/06	FIRST ISSUE				7						14					

ALL PROPRIETARY RIGHTS IN THE SUBJECT MATTER HEREOF ARE RESERVED, AND NO PERMISSION IS GRANTED TO REPRODUCE THIS PRINT IN WHOLE OR IN PART, OR DISCLOSE ANY OF THE INFORMATION UPON IT TO OTHERS WITHOUT WRITTEN RELEASE BY YORK INTERNATIONAL CORPORATION.