

MVVSD1000R_-84
 MVVSD1250R_-84
 MVVSD1500R_-84
 MVVSD1750R_-84
 MVVSD2000R_-84

T = YT UNITS
 K = YK/YD/YKEP UNITS

NO	DRAWING NO	REV	DRAWING DESCRIPTION
00	I808JD00	8	MEDIUM VOLTAGE FLOOR MOUNT VFD
01	---	---	----
02	---	---	----
03	I808JD03	0	GROUNDING PROCEDURE
04	---	---	----
05	I808JD05	3	RATING SHEET
06	---	---	----
07	I808JD07	2	ONE-LINE DIAGRAM
08	---	---	----
09	---	---	----
10	I808JD10	3	THREE-LINE DIAGRAM
11	I808JD11	3	MAIN CIRCUIT
12	I808JD12	1	RECTIFIER CIRCUIT
13	---	---	----
14	---	---	----
15	I808JD15	2	CONTROL POWER AND FAN CIRCUITS

NO	DRAWING NO	REV	DRAWING DESCRIPTION
16	I808JD16	3	PCB INTERCONNECTION (1)
17	I808JD17	1	PCB INTERCONNECTION (2)
18	I808JD18	1	EXTERNAL I/O (1)
19	I808JD19	1	EXTERNAL I/O (2)
20	I808JD20	3	CONTROL CIRCUIT
21	---	---	----
22	---	---	----
23	---	---	----
24	---	---	----
25	---	---	----
26	---	---	----
27	---	---	----
28	I808JD28	3	CHILLER SYSTEM TERMINAL CONNECTIONS
29	---	---	----
30	I808JD30	1	ENCLOSURE OUTLINE
31	---	---	----

REV. LEV.	DATE	REVISION RECORD	CHG. NO.	DR.	CK.	REV. LEV.	DATE	REVISION RECORD	CHG. NO.	DR.	CK.	REV. LEV.	DATE	REVISION RECORD	CHG. NO.	DR.	CK.
6	06/16/13	SHT 11		JO	AL	13						20					
5	06/23/11	REVISED 5,7,11		XZ	AL	12						19					
4	07/22/10	REVISED		XZ	AL	11						18					
3	11/05/09	REVISED SHEET 5,15,16		XZ	AL	10						17					
2	05/22/08	REVISED		OB	AL	9	04/08/16	REVISED PAGES 10, 20 AND 28		JAT	AL	16					
1	02/05/08	REVISED		OB	AL	8	11/12/15	REVISED PAGE 20		RG	JO	15					
0	04/28/06	FIRST ISSUE		OB	AL	7	06/05/14	UPGRADED TO ACE FORMAT		JO	AL	14					

ALL PROPRIETARY RIGHTS IN THE SUBJECT MATTER HEREOF ARE RESERVED, AND NO PERMISSION IS GRANTED TO REPRODUCE THIS PRINT IN WHOLE OR IN PART, OR DISCLOSE ANY OF THE INFORMATION UPON IT TO OTHERS WITHOUT WRITTEN RELEASE BY YORK INTERNATIONAL CORPORATION.

YORK INTERNATIONAL CORPORATION YORK, PA .17405			
DIMENSIONS ARE IN INCHES DO NOT SCALE TOLERANCES PER ENG. STD. M-282 WELDING PER ENG. STD. M-30 REF. DWG.		MEDIUM VOLTAGE VFD FLOOR MOUNT FRAME 1 4160V	
DR. NAME _____ DATE _____		SIZE D	CAGE NO _____
APPR. _____		DRAWING NUMBER I808JD00	
SCALE: _____		WT. = _____ LBS.	ORIG. NO. _____ SHEET 1 of 15

STANDARD PANEL GROUNDING PROCEDURES
TO BE FOLLOWED AT INSTALLATION

SCOPE

THIS DRAWING WILL DOCUMENT PROCEDURES WHICH ARE TO BE FOLLOWED BY CUSTOMER'S CONTRACTOR WHEN INSTALLING INDUSTRIAL DRIVE AND MOTOR SYSTEMS

IN ORDER TO UNDERSTAND THE REASONS FOR MANY OF THE PRACTICES THAT ARE RECOMMENDED, IT IS HELPFUL TO SEGREGATE THESE PRACTICES INTO TWO CATEGORIES AS FOLLOWS:

1) THOSE GENERALLY REFERRED TO AS EQUIPMENT GROUNDING PRACTICES WHOSE PURPOSES ARE:

- TO PROTECT AGAINST THE RISK OF ELECTRICAL SHOCK OR BURN.
- TO PROTECT THE EQUIPMENT FROM FIRE OR OTHER DAMAGE DUE TO GROUND FAULTS OR LIGHTNING STRIKES.

THESE PRACTICES WOULD TYPICALLY BE FOLLOWED BY THE CONTRACTOR IN COMPLIANCE WITH NEC OR OTHER CODE REQUIREMENTS.

2) THOSE PRACTICES WHICH MAKE THE EQUIPMENT IMMUNE TO ELECTRICAL NOISE ORIGINATING WITHIN OR OUTSIDE THE EQUIPMENT. THESE COMPLEMENT THE EQUIPMENT GROUNDING AND LEVEL WIRING PRACTICES IN PROVIDING NOISE IMMUNITY.

EQUIPMENT GROUNDING

- 1) ALL METAL BUILDING STRUCTURES SUCH AS COLUMNS, FLOOR BEAMS, ETC. SHOULD BE GROUNDED BY AN INTERCONNECTING HEAVY GROUND CABLE (5) IN ACCORDANCE WITH RECOMMENDED BUILDING PRACTICES AND LOCAL CODES.
- 2) ALL ELECTRICAL JOINTS AND CONNECTIONS TO THE BUILDING STRUCTURES SHOULD BE BRAZED OR EXOTHERMIC WELDED TO ASSURE THAT THE REQUIRED GOOD ELECTRICAL AND MECHANICAL PROPERTIES DO NOT DETERIORATE WITH THE PASSAGE OF TIME.
- 3) ALL PANELS SHOULD BE GROUNDED AT LEAST ONE POINT USING A HEAVY SAFETY CABLE (7). PANELS GREATER THAN 15 FT LONG SHOULD BE GROUNDED AT BOTH ENDS. THE GROUND CABLE NEEDS TO BE AT LEAST 1/0 AWG FOR MECHANICAL REASONS AND NEED NOT BE GREATER THAN 500 MCM. THIS CABLE IS USUALLY NON-INSULATED.
- 4) THE SAFETY GROUND CABLE (7) SHOULD BE BRAZED OR EXOTHERMIC WELDED (7A) TO A BUILDING STEEL STRUCTURE THAT IS CLOSEST TO THE PANEL, PREFERABLY WITHIN 25 FT.
- 5) THE EQUIPMENT END (7B) SHOULD BE BOLTED OR BRAZED TO A GROUND TERMINATION POINT ON THE PANEL.
- 6) THE EQUIPMENT GROUNDING TERMINAL IS A COPPER GROUND BUS OR STUB BUS BONDED TO THE PANEL ENCLOSURE USING BRAZING OR BOLTING IN SUCH MANNER THAT THE CONDUCTING PATH HAS A RESISTANCE OF 0.1 OHMS OR LESS.
- 7) THE GROUNDING CONDUCTORS MUST BE CAPABLE OF HANDLING ANTICIPATED GROUND FAULT CURRENTS.
- 8) THERE SHOULD BE A JUMPER CABLE (11) ACROSS THE GROUND BUS FLOOR SILL BETWEEN ANY SHIPPING SPLITS AND SIZED THE SAME AS THE SAFETY GROUND UNLESS OTHERWISE SPECIFIED.
- 9) THE PROTECTIVE GROUNDING DESCRIBED ABOVE FOR POWER CONVERSION AND CONTROL CABINETS IS ALSO NEEDED FOR MOTORS, TRANSFORMERS AND REACTORS. EACH OF THESE SHOULD HAVE ITS OWN GROUNDING CONDUCTOR GOING DIRECTLY TO THE BUILDING GROUND GRID.

GROUNDING PROCEDURES NEEDED TO ENSURE ELECTRICAL NOISE IMMUNITY

- 1) LEVELING BEAMS, STEEL MESH, GALVANIZED FLOOR, DECKING, ETC. SHOULD BE INSTALLED PRIOR TO PLACING THE EQUIPMENT. THESE SHOULD BE CONNECTED TO THE BUILDING GROUND SYSTEM USING A BRAZING OR EXOTHERMIC WELDING PROCESS.
- 2) GROUNDING LEVELING BEAMS ARE NOT AN ABSOLUTE NECESSITY FOR SATISFACTORY OPERATION. ON NEW CONSTRUCTION SUCH BEAMS CAN BE PROVIDED WITH LITTLE DIFFICULTY. FOR EXISTING CONSTRUCTION IT USUALLY WILL BE MORE DIFFICULT, IN WHICH CASE THE LEVELING BEAMS MAY BE DISPENSED WITH, PROVIDED OTHER GROUNDED STRUCTURES SUCH AS COLUMNS AND FLOOR BEAMS ARE WITHIN 10 FEET OF THE EQUIPMENT.
- 3) AFTER SETTING THE CONTROL PANELS IN PLACE, THE PERIPHERY OF THE CONTROL PANELS SHOULD BE SPOT WELDED TO THE STEEL CHANNELS APPROXIMATELY EVERY 18 INCHES. THIS CREATES A VERY GOOD HIGH FREQUENCY GROUND PLANE. CARE SHOULD BE TAKEN TO AVOID ELECTRONIC COMPONENT DAMAGE DURING THE WELDING PROCESS BY KEEPING THE WELDED RETURN PATH AS CLOSE AS POSSIBLE TO THE WORK POSITION. THAT IS, THE RETURN PATH SHOULD ALWAYS BE WITHIN 3 FEET OF THE ELECTRODE.
- 4) IF LEVELING BEAMS ARE NOT INSTALLED, A NUMBER OF GROUNDING CABLES (7C) SHOULD BE RUN FROM THE GROUND LUGS PROVIDED ON THE PANEL TO THE NEAREST GROUNDED COLUMN OR FLOOR BEAM, OR WIRE FLOOR MESH, ETC. THIS WILL PROVIDE THE NECESSARY HIGH FREQUENCY GROUND PLANE.

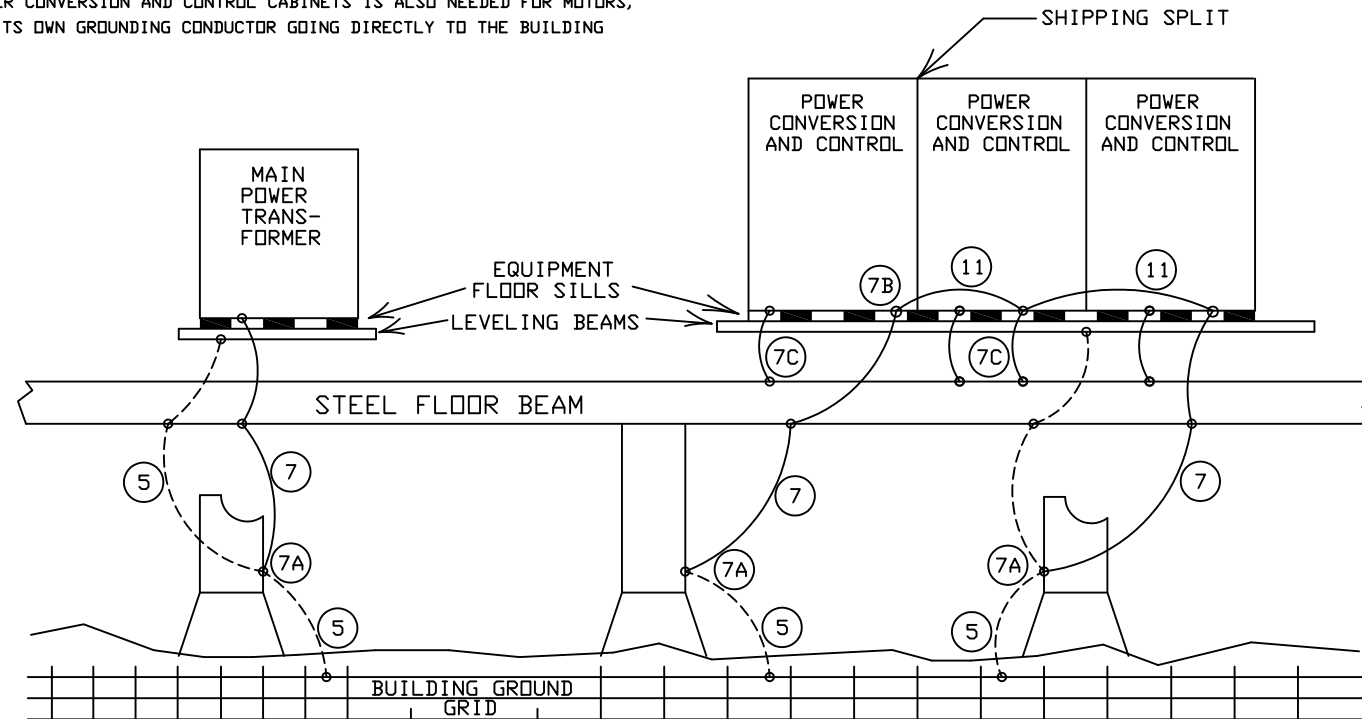

REV. LEV.	DATE	REVISION RECORD	CHG. NO.	DR.	CK.	REV. LEV.	DATE	REVISION RECORD	CHG. NO.	DR.	CK.	REV. LEV.	DATE	REVISION RECORD	CHG. NO.	DR.	CK.
6						13						20					
5						12						19					
4						11						18					
3						10						17					
2						9						16					
1						8						15					
0	10/22/2014	FIRST ISSUE		JO	AL	7						14					

ALL PROPRIETARY RIGHTS IN THE SUBJECT MATTER HEREOF ARE RESERVED, AND NO PERMISSION IS GRANTED TO REPRODUCE THIS PRINT IN WHOLE OR IN PART, OR DISCLOSE ANY OF THE INFORMATION UPON IT TO OTHERS WITHOUT WRITTEN RELEASE BY YORK INTERNATIONAL CORPORATION.

YORK INTERNATIONAL CORPORATION YORK, PA .17405			
DIMENSIONS ARE IN INCHES DO NOT SCALE TOLERANCES PER ENG. STD. M-282 WELDING PER ENG. STD. M-30 REF. DWG.		GROUNDING PROCEDURE	MATERIAL TYPE _____ ENG. STD. _____ PART NO. _____ CUT SIZE _____
DR. _____	DATE _____	SIZE D	CAGE NO. _____
APPR. _____	SCALE _____	DRAWING NUMBER 1808JD03	
WT. = _____	LBS. _____	ORIG. NO. _____	SHEET 2 of 15

COMPONENT RATING		
SHEET NUMBER	COMPONENT	MVSD1000R_-84 ~ 2000R_-84
		RATING
5	10LA	6kV
	10ISW1	360A, 6.6kV
	10FU1~3	SEE TABLE A
	10M1	360A, 6.6kV
	10M1A	360A, 6.6kV
	10ACL	17.9mH
	10F4~7	2E, 4.8kV
	10PT1~2	500VA, 4200:120V
	10CPT	SEE TABLE A
	10F8~10	3E, 4.8kV
	10F12~14	SEE TABLE A
	10F15	20A, 600Vac
	6	HCTU,HCTW
11T1		SEE TABLE A
11R11		100k ohm, 225W
GDI		---
11L1		100uH, 260A
7	FUSE	SEE TABLE A
	DIODE	2200V, 260A
	POWER MODULE (U,V,W)	±1800Vdc, 248A
8	15MCB1	15A, 600V
	15V1	480V, 2a2b
	15MS1~2	1.6~2.5A, 480V (set @ 2.3A)
	15MOV1~3	625V, 230J
	15FN1~2	460V, 1.2kW
	15MCB2	240Vac, 20A, 2P
	15F1~2	5A, 600Vac
	PDM	---
	15PS1	120/240:+5,+/-15,24V,80W
	15DS1	10A, 600V
	VX	25A, 4a4b/2a2b, 120Vac
	9	CTR
GSD		---
16R1,3		SEE TABLE A
16R2,4		SEE TABLE A
MODBUS		ETHERNET/RTU (RS485)
10	IPAD	---
	DISP	G7A
	XIO	---
11	BLR	24Vdc, 4a0b
	FLT,INPC	24Vdc, 2a2b
13	EXT	115V, 4a0b
	SS	50-129V AC/DC

MODEL NUMBER	MOTOR HP	DRIVE FLA	OIL PUMP TYPE	10FU1~3 RATING	10CPT RATING	10F12~14 RATING	11T1 RATING	FUSE RATING	16R1,3 RATING	16R2,4 RATING
MVSD1000RT-84	1000	125	YT	200E, 5.5KV	4160:460V-2KVA,115V-2KVA	5A, 600V	873kVA,4160V:635V(12)	700V, 200A	32 ohm, 3W, 1%	25 ohm, 3W, 1%
MVSD1000RK-84	1000	125	YK	200E, 5.5KV	4160:460V-3KVA,115V-2KVA	7A, 600V	873kVA,4160V:635V(12)	700V, 200A	32 ohm, 3W, 1%	25 ohm, 3W, 1%
MVSD1250RT-84	1250	155	YT	200E, 5.5KV	4160:460V-2KVA,115V-2KVA	5A, 600V	1085kVA,4160V:635V(12)	700V, 200A	35 ohm, 3W, 1%	10 ohm, 3W, 1%
MVSD1250RK-84	1250	155	YK	200E, 5.5KV	4160:460V-3KVA,115V-2KVA	7A, 600V	1085kVA,4160V:635V(12)	700V, 200A	35 ohm, 3W, 1%	10 ohm, 3W, 1%
MVSD1500RT-84	1500	186	YT	250E, 5.5KV	4160:460V-2KVA,115V-2KVA	5A, 600V	1296kVA,4160V:635V(12)	700V, 200A	35 ohm, 3W, 1%	3 ohm, 3W, 1%
MVSD1500RK-84	1500	186	YK	250E, 5.5KV	4160:460V-3KVA,115V-2KVA	7A, 600V	1296kVA,4160V:635V(12)	700V, 200A	35 ohm, 3W, 1%	3 ohm, 3W, 1%
MVSD1750RT-84	1750	217	YT	300E, 5.5KV	4160:460V-2KVA,115V-2KVA	5A, 600V	1508kVA,4160V:635V(12)	700V, 250A	30 ohm, 3W, 1%	3 ohm, 3W, 1%
MVSD1750RK-84	1750	217	YK	300E, 5.5KV	4160:460V-3KVA,115V-2KVA	7A, 600V	1508kVA,4160V:635V(12)	700V, 250A	30 ohm, 3W, 1%	3 ohm, 3W, 1%
MVSD2000RT-84	2000	248	YT	350E, 5.5KV	4160:460V-2KVA,115V-2KVA	5A, 600V	1720kVA,4160V:635V(12)	700V, 250A	25 ohm, 3W, 1%	3 ohm, 3W, 1%
MVSD2000RK-84	2000	248	YK	350E, 5.5KV	4160:460V-3KVA,115V-2KVA	7A, 600V	1720kVA,4160V:635V(12)	700V, 250A	25 ohm, 3W, 1%	3 ohm, 3W, 1%

YORK INTERNATIONAL CORPORATION
YORK, PA .17405

REV. LEV.	DATE	REVISION RECORD	CHG. NO.	DR.	CK.	REV. LEV.	DATE	REVISION RECORD	CHG. NO.	DR.	CK.	REV. LEV.	DATE	REVISION RECORD	CHG. NO.	DR.	CK.
6						13						20					
5						12						19					
4						11						18					
3	06/05/11	UPGRADED TO ACE FORMAT		JO	AL	10						17					
2	06/23/11	ADDED 11L1		XZ	AL	9						16					
1	11/05/09	REVISED SHEET 11,13		XZ	AL	8						15					
0	04/20/06	FIRST ISSUE		OB	AL	7						14					

ALL PROPRIETARY RIGHTS IN THE SUBJECT MATTER HEREOF ARE RESERVED, AND NO PERMISSION IS GRANTED TO REPRODUCE THIS PRINT IN WHOLE OR IN PART, OR DISCLOSE ANY OF THE INFORMATION UPON IT TO OTHERS WITHOUT WRITTEN RELEASE BY YORK INTERNATIONAL CORPORATION.

DIMENSIONS ARE IN INCHES DO NOT SCALE TOLERANCES PER ENG. STD. M-282 WELDING PER ENG. STD. M-30 REF. DWG.		RATING SHEET, COMPONENTS		MATERIAL TYPE _____ ENG. STD. _____ PART NO. _____ CUT SIZE _____	
DR. _____	DATE _____	SIZE D	CAGE NO. _____	DRAWING NUMBER 1808JD05	
APPR. _____	SCALE: _____	WT. = _____ LBS.	ORIG. NO. _____	SHEET 3 of 15	

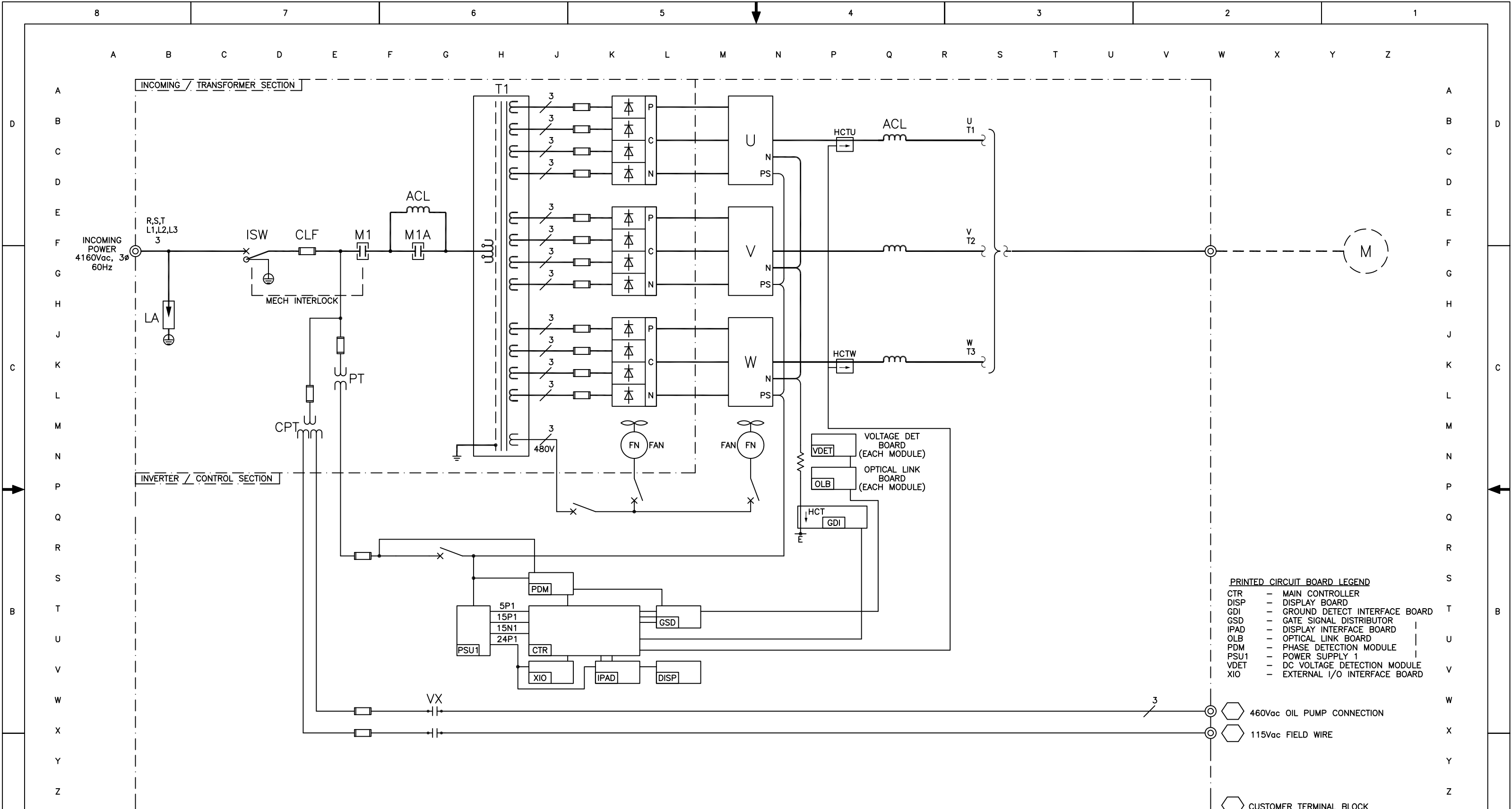

- PRINTED CIRCUIT BOARD LEGEND**
- CTR - MAIN CONTROLLER
 - DISP - DISPLAY BOARD
 - GDI - GROUND DETECT INTERFACE BOARD
 - GSD - GATE SIGNAL DISTRIBUTOR
 - IPAD - DISPLAY INTERFACE BOARD
 - OLB - OPTICAL LINK BOARD
 - PDM - PHASE DETECTION MODULE
 - PSU1 - POWER SUPPLY 1
 - VDET - DC VOLTAGE DETECTION MODULE
 - XIO - EXTERNAL I/O INTERFACE BOARD

- 460Vac OIL PUMP CONNECTION
- 115Vac FIELD WIRE
- CUSTOMER TERMINAL BLOCK

YORK INTERNATIONAL CORPORATION
YORK, PA . 17405

DIMENSIONS ARE IN INCHES DO NOT SCALE TOLERANCES PER ENG. STD. M-282 WELDING PER ENG. STD. M-30 REF. DWG.		ONE-LINE DIAGRAM		MATERIAL TYPE _____ ENG. STD. _____ PART NO. _____ CUT SIZE _____	
DR. _____	NAME _____	DATE _____	SIZE D	CAGE NO. _____	DRAWING NUMBER 1808JD07
APPR. _____	WT. = _____		LBS.	ORIG. NO. _____	SHEET 4 of 15

REV. LEV.	DATE	REVISION RECORD	CHG. NO.	DR.	CK.	REV. LEV.	DATE	REVISION RECORD	CHG. NO.	DR.	CK.	REV. LEV.	DATE	REVISION RECORD	CHG. NO.	DR.	CK.
6						13						20					
5						12						19					
4						11						18					
3						10						17					
2	06/05/14	UPGRADED TO ACE FORMAT				9						16					
1	06/23/11	ADDED ACL				8						15					
0	04/20/06	FIRST ISSUE				7						14					

*ALL PROPRIETARY RIGHTS
IN THE SUBJECT MATTER
HEREOF ARE RESERVED,
AND NO PERMISSION IS
GRANTED TO REPRODUCE
THIS PRINT IN WHOLE
OR IN PART, OR DISCLOSE
ANY OF THE INFORMATION
UPON IT TO OTHERS
WITHOUT WRITTEN RELEASE
BY YORK INTERNATIONAL
CORPORATION.*

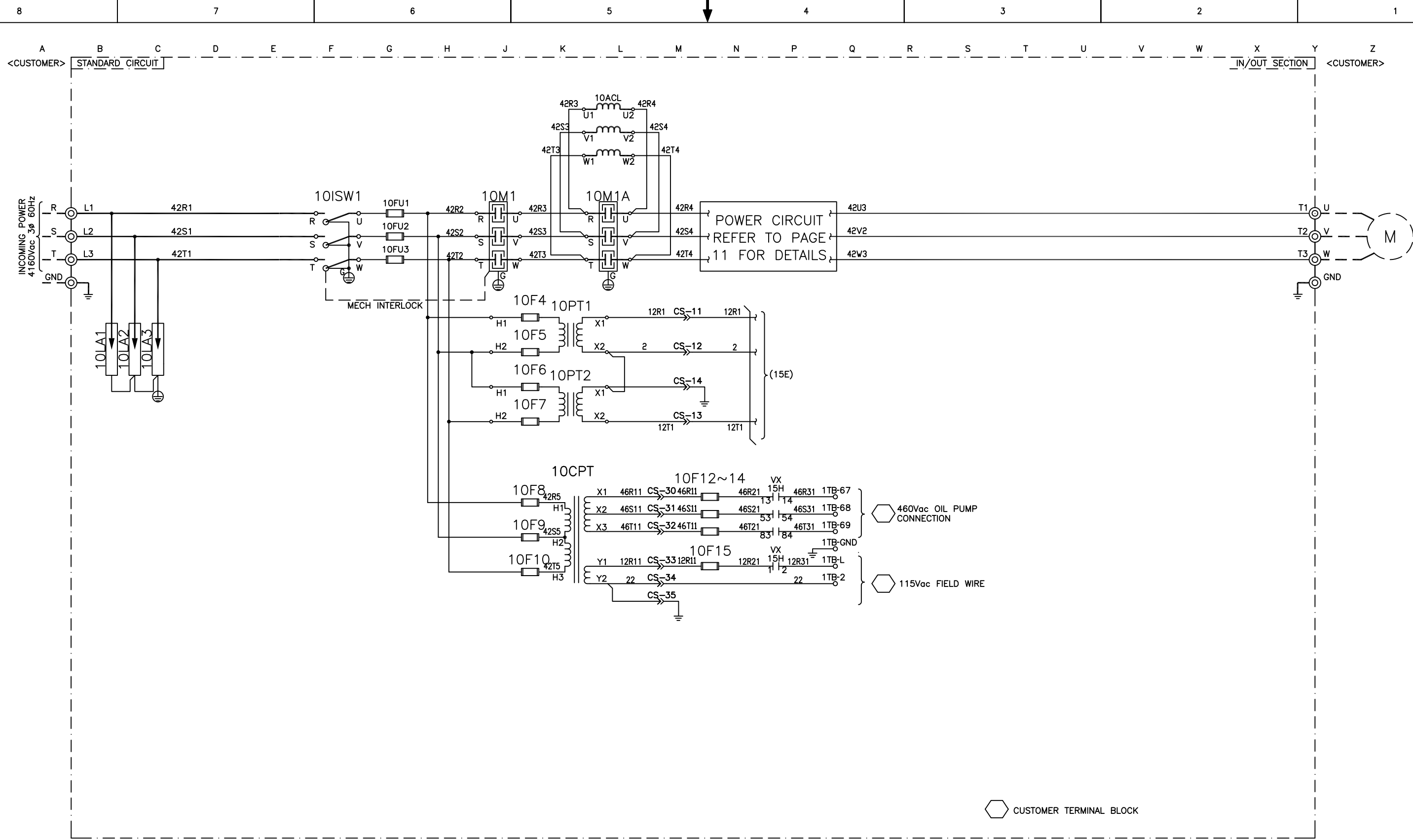

CUSTOMER TERMINAL BLOCK

CUSTOMER TERMINAL BLOCK

REV. LEV.	DATE	REVISION RECORD	CHG. NO.	DR.	CK.	REV. LEV.	DATE	REVISION RECORD	CHG. NO.	DR.	CK.	REV. LEV.	DATE	REVISION RECORD	CHG. NO.	DR.	CK.
6						13						20					
5						12						19					
4						11						18					
3	06/08/16	REMOVED 1TB-GND		JAT	AL	10						17					
2	06/16/14	UPGRADED TO ACE FORMAT		JO	AL	9						16					
1	05/22/08	ADDED CS-35		OB	AL	8						15					
0	04/28/06	FIRST ISSUE		OB	AL	7						14					

ALL PROPRIETARY RIGHTS IN THE SUBJECT MATTER HEREOF ARE RESERVED, AND NO PERMISSION IS GRANTED TO REPRODUCE THIS PRINT IN WHOLE OR IN PART, OR DISCLOSE ANY OF THE INFORMATION UPON IT TO OTHERS WITHOUT WRITTEN RELEASE BY YORK INTERNATIONAL CORPORATION.

YORK INTERNATIONAL CORPORATION
YORK, PA . 17405

DIMENSIONS ARE IN INCHES DO NOT SCALE TOLERANCES PER ENG. STD. M-282 WELDING PER ENG. STD. M-30 REF. DWG.		THREE-LINE DIAGRAM		MATERIAL TYPE _____ ENG. STD. _____ PART NO. _____ CUT SIZE _____	
DR. _____	DATE _____	SIZE D	CAGE NO. _____	DRAWING NUMBER 1808JD10	
APPR. _____	SCALE _____	WT. = _____ LBS.	ORIG. NO. _____	SHEET 5 of 15	

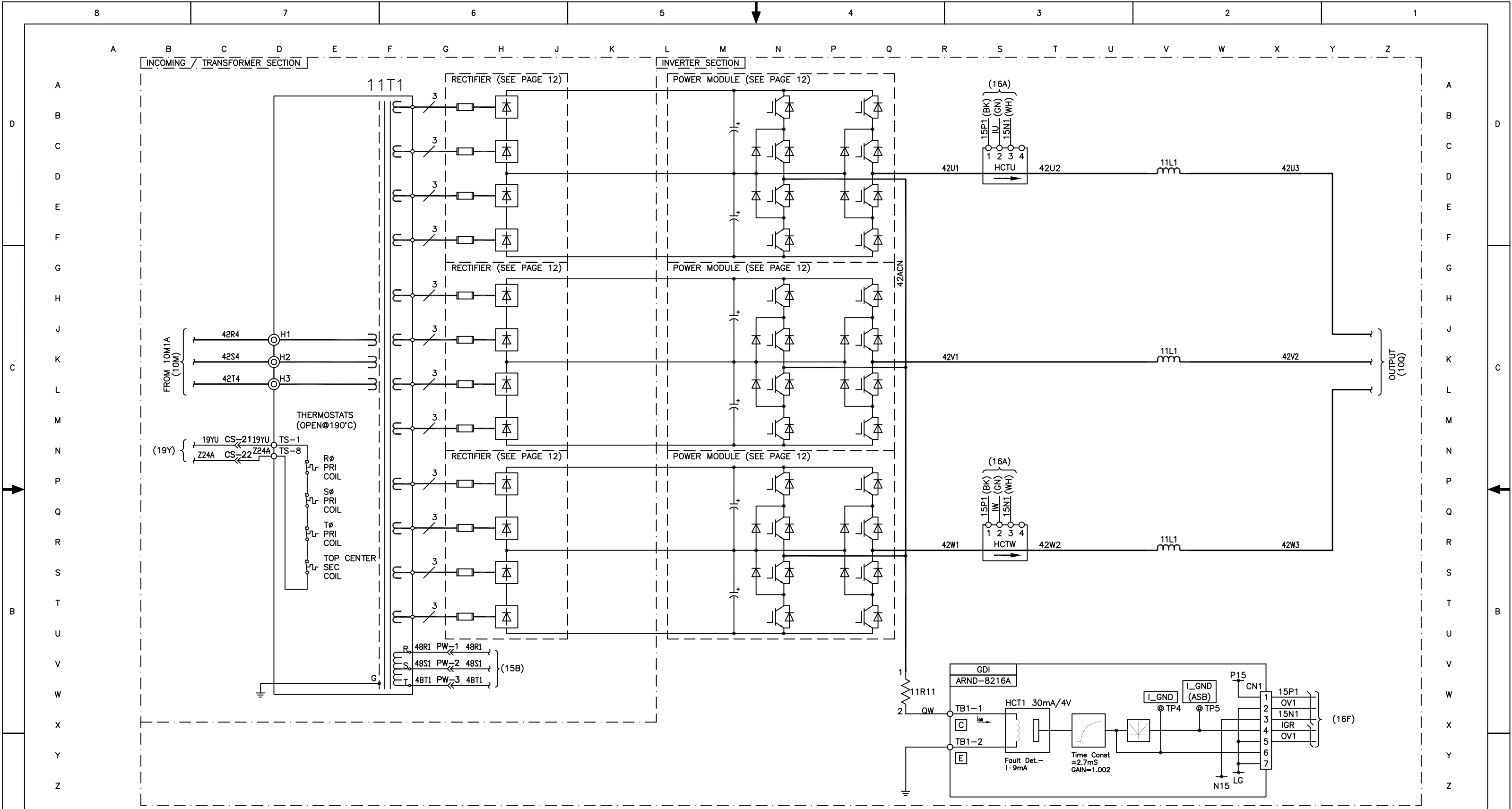

YORK INTERNATIONAL CORPORATION YORK, PA . 17405																			
REVISION RECORD										DIMENSIONS ARE IN INCHES DO NOT SCALE TOLERANCES PER ENG. STD. M-282 WELDING PER ENG. STD. M-30 REF. DWG.		MAIN CIRCUIT		MATERIAL TYPE _____ ENG. STD. _____ PART NO. _____ CUT SIZE _____					
REV. LEV.	DATE	CHG. NO.	DR.	CK.	REV. LEV.	DATE	CHG. NO.	DR.	CK.	REV. LEV.	DATE	CHG. NO.	DR.	CK.	NAME	DATE	SIZE	CAGE NO.	DRAWING NUMBER
6					13					20							D		1808JD11
5					12					19									
4					11					18									
3	06/25/74		JO	AL	10					17									
2	08/16/73		JO	AL	9					16									
1	06/23/71		XZ	AL	8					15									
0	04/20/66		OB	AL	7					14									

*ALL PROPRIETARY RIGHTS
IN THE SUBJECT MATTER
HEREOF ARE RESERVED,
AND NO PERMISSION IS
GRANTED TO REPRODUCE
THIS PRINT IN WHOLE
OR IN PART, OR DISCLOSE
ANY OF THE INFORMATION
UPON IT TO OTHERS
WITHOUT WRITTEN RELEASE
BY YORK INTERNATIONAL
CORPORATION.*

DR. _____ DATE _____ SIZE _____ CAGE NO. _____
APPR. _____
SCALE: _____ WT. = _____ LBS. ORIG. NO. _____ SHEET 6 of 15

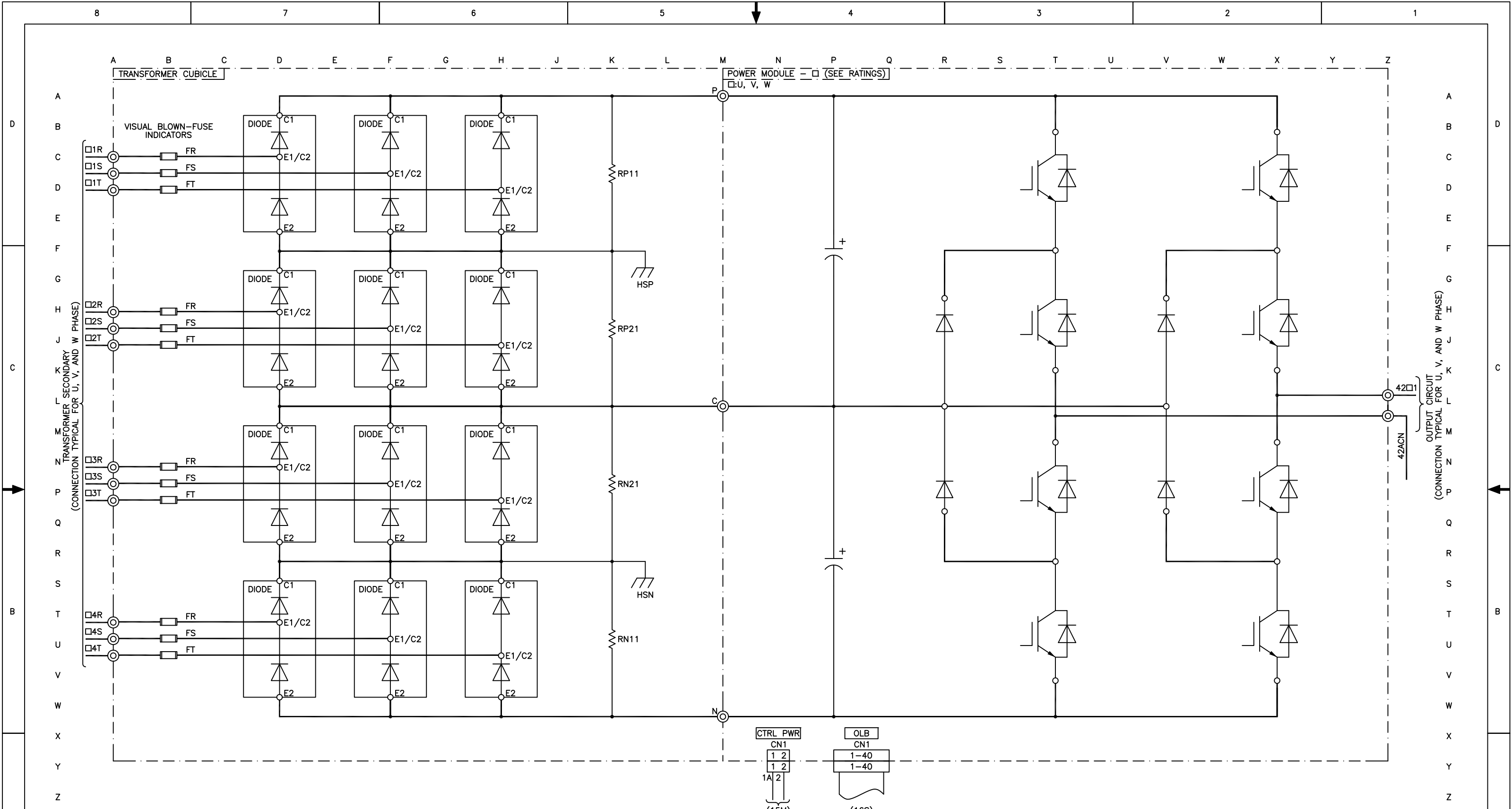

YORK INTERNATIONAL CORPORATION YORK, PA . 17405																				
REVISION RECORD				REVISION RECORD				REVISION RECORD				REVISION RECORD								
REV. LEV.	DATE	CHG. NO.	DR.	CK.	REV. LEV.	DATE	CHG. NO.	DR.	CK.	REV. LEV.	DATE	CHG. NO.	DR.	CK.	REV. LEV.	DATE	CHG. NO.	DR.	CK.	
6					13					20										
5					12					19										
4					11					18										
3					10					17										
2					9					16										
1	06/05/14				8					15										
0	04/20/06	UPGRADED TO ACE FORMAT			7					14										
		FIRST ISSUE																		

DR. _____		DATE _____		SIZE D	CAGE NO. _____	DRAWING NUMBER 1808JD12	
APPR. _____		SCALE _____		WT. = _____	LBS. _____	ORIG. NO. _____	SHEET 7 of 15

ALL PROPRIETARY RIGHTS IN THE SUBJECT MATTER HEREOF ARE RESERVED, AND NO PERMISSION IS GRANTED TO REPRODUCE THIS PRINT IN WHOLE OR IN PART, OR DISCLOSE ANY OF THE INFORMATION UPON IT TO OTHERS WITHOUT WRITTEN RELEASE BY YORK INTERNATIONAL CORPORATION.

DIMENSIONS ARE IN INCHES DO NOT SCALE TOLERANCES PER ENG. STD. M-282 WELDING PER ENG. STD. M-30 REF. DWG.

RECTIFIER CKT. (ONE PHASE)
MATERIAL TYPE _____ ENG. STD. _____
PART NO. _____
CUT SIZE _____

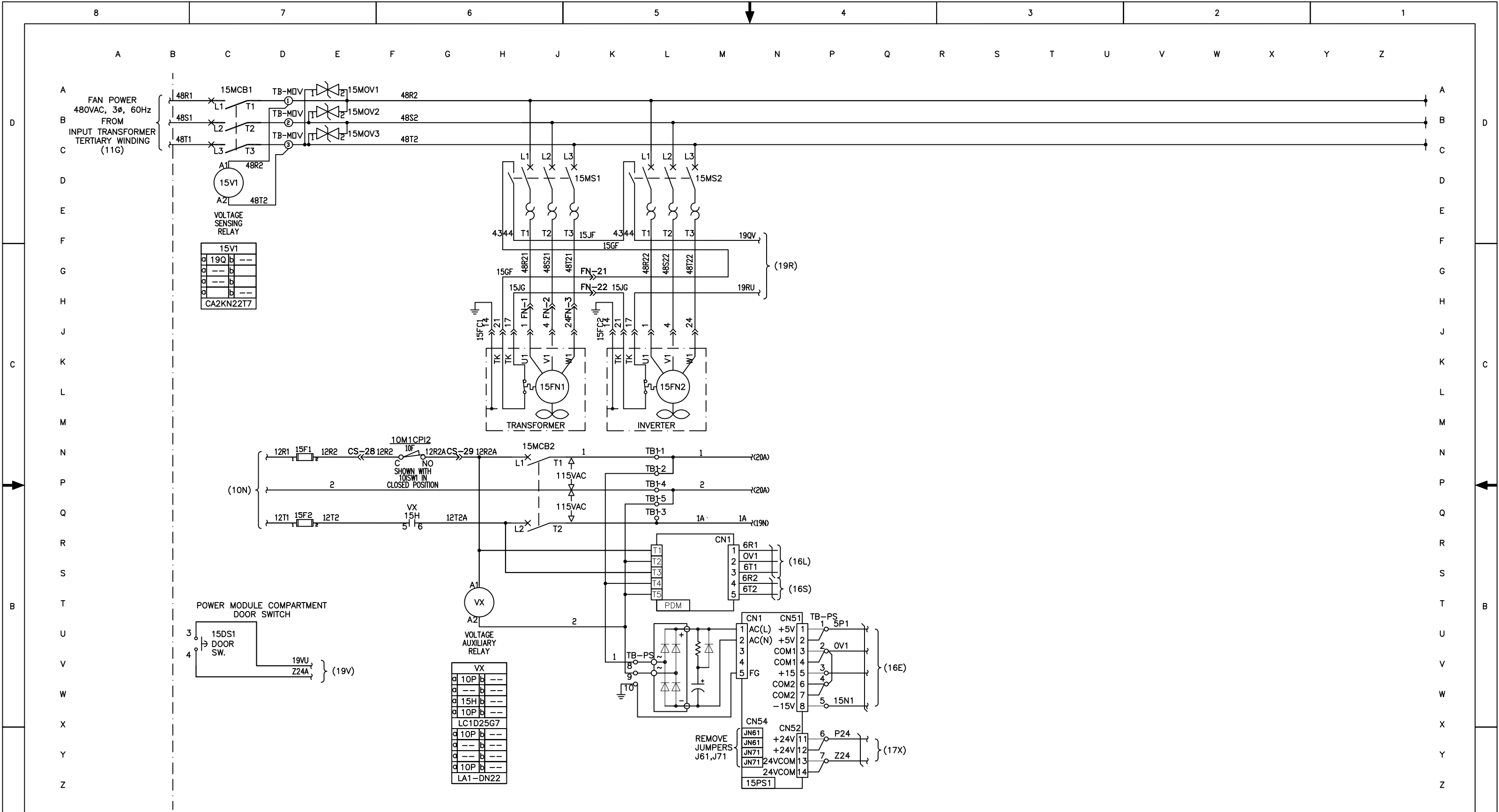

15V1	
a	19Q
b	---
a	---
b	---
a	---
b	---
a	---
b	---
CA2KN22T7	

VX	
a	10P
b	---
a	15H
b	---
a	10P
b	---
a	10P
b	---
a	10P
b	---
LC1D25G7	
a	10P
b	---
a	---
b	---
a	10P
b	---
LA1-DN22	

REMOVE JUMPERS J61, J71	
a	JN61
b	+24V
a	JN61
b	+24V
a	JN71
b	+24V
a	JN71
b	24VCOM
a	JN71
b	24VCOM
15PS1	

YORK INTERNATIONAL CORPORATION
YORK, PA .17405

DIMENSIONS ARE IN INCHES DO NOT SCALE TOLERANCES PER ENG. STD. M-282 WELDING PER ENG. STD. M-30 REF. DWG.		CONTROL POWER AND FANS CIRCUIT		MATERIAL TYPE _____ ENG. STD. _____ PART NO. _____ CUT SIZE _____	
DR. _____	DATE _____	SIZE D	CAGE NO. _____	DRAWING NUMBER 1808JD15	
APPR. _____	SCALE _____	WT. = _____	LBS. _____	ORIG. NO. _____	SHEET 8 of 15

REV. LEV.	DATE	REVISION RECORD	CHG. NO.	DR.	CK.	REV. LEV.	DATE	REVISION RECORD	CHG. NO.	DR.	CK.	REV. LEV.	DATE	REVISION RECORD	CHG. NO.	DR.	CK.
6						13						20					
5						12						19					
4						11						18					
3						10						17					
2	06/15/14	UPGRADED TO ACE FORMAT				9						16					
1	11/05/09	REVISED TB-PS				8						15					
0	04/20/06	FIRST ISSUE				7						14					

ALL PROPRIETARY RIGHTS IN THE SUBJECT MATTER HEREOF ARE RESERVED, AND NO PERMISSION IS GRANTED TO REPRODUCE THIS PRINT IN WHOLE OR IN PART, OR DISCLOSE ANY OF THE INFORMATION UPON IT TO OTHERS WITHOUT WRITTEN RELEASE BY YORK INTERNATIONAL CORPORATION.

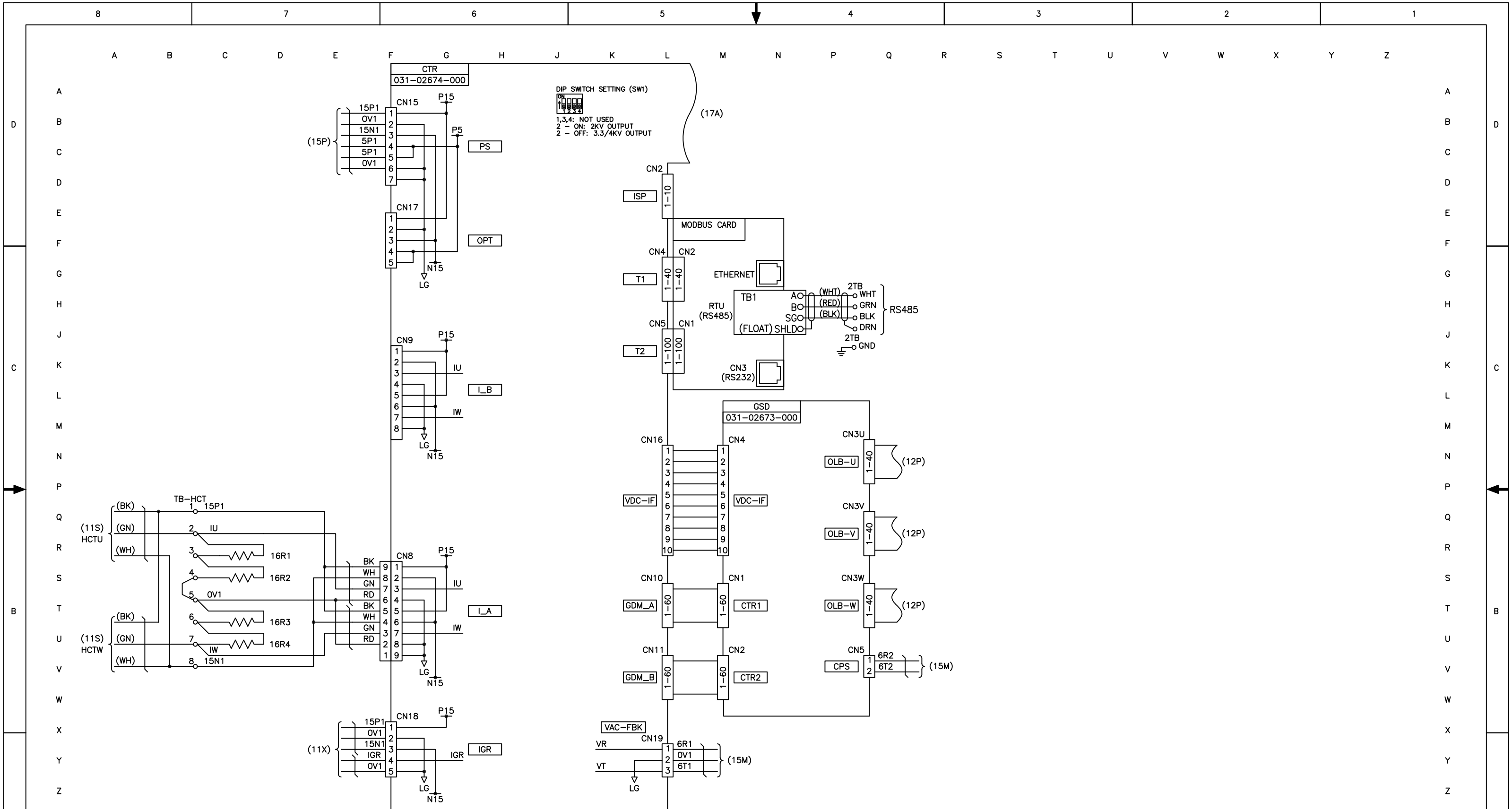

DIP SWITCH SETTING (SW1)

1	2	3	4
1	2	3	4

1,3,4: NOT USED
 2 - ON: 2KV OUTPUT
 2 - OFF: 3.3/4KV OUTPUT

YORK INTERNATIONAL CORPORATION
 YORK, PA . 17405

PCB (1)
 INTERCONNECTION

MATERIAL
 TYPE _____ ENG. STD. _____
 PART NO. _____
 CUT SIZE _____

NAME _____ DATE _____ SIZE _____ CAGE NO. _____ DRAWING NUMBER
 1808JD16

WT. = _____ LBS. ORIG. NO. _____ SHEET 9 of 15

REV. LEV.	DATE	REVISION RECORD	CHG. NO.	DR.	CK.	REV. LEV.	DATE	REVISION RECORD	CHG. NO.	DR.	CK.	REV. LEV.	DATE	REVISION RECORD	CHG. NO.	DR.	CK.
6						13						20					
5						12						19					
4						11						18					
3	06/05/14	UPGRADED TO ACE FORMAT		JO	AL	10						17					
2	11/05/09	REVISED CTR-CN15		XZ	AL	9						16					
1	02/05/06	REMOVED 2TB JUMPER & RES		OB	AL	8						15					
0	04/28/06	FIRST ISSUE		OB	AL	7						14					

*ALL PROPRIETARY RIGHTS IN THE SUBJECT MATTER HEREOF ARE RESERVED, AND NO PERMISSION IS GRANTED TO REPRODUCE THIS PRINT IN WHOLE OR IN PART, OR DISCLOSE ANY OF THE INFORMATION UPON IT TO OTHERS WITHOUT WRITTEN RELEASE BY YORK INTERNATIONAL CORPORATION.

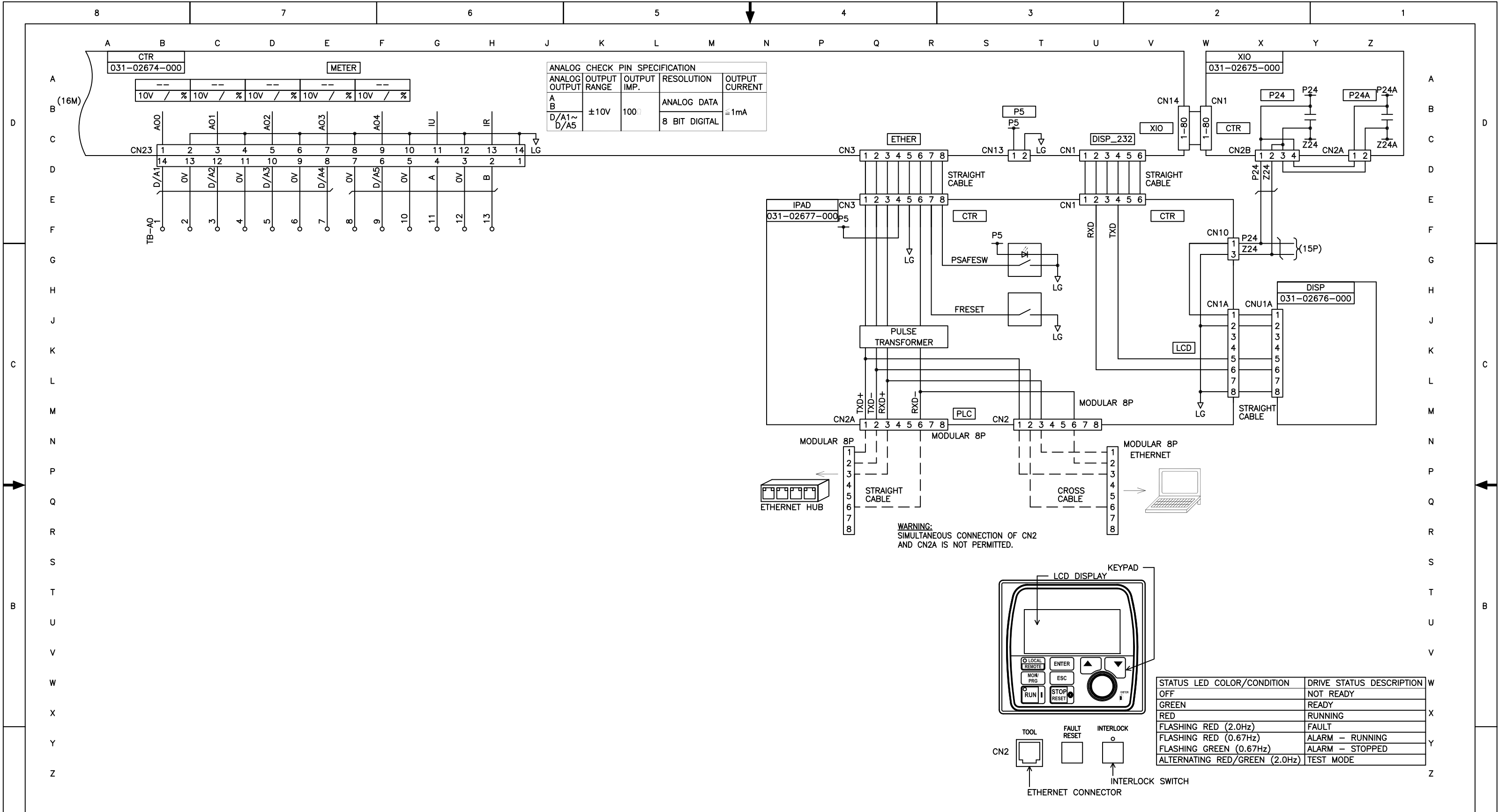

ANALOG CHECK PIN SPECIFICATION

ANALOG OUTPUT	OUTPUT RANGE	OUTPUT IMP.	RESOLUTION	OUTPUT CURRENT
A	±10V	100Ω	ANALOG DATA	≅1mA
B			8 BIT DIGITAL	

WARNING:
SIMULTANEOUS CONNECTION OF CN2
AND CN2A IS NOT PERMITTED.

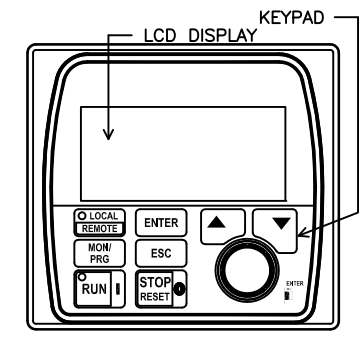

STATUS LED COLOR/CONDITION	DRIVE STATUS DESCRIPTION
OFF	NOT READY
GREEN	READY
RED	RUNNING
FLASHING RED (2.0Hz)	FAULT
FLASHING RED (0.67Hz)	ALARM - RUNNING
FLASHING GREEN (0.67Hz)	ALARM - STOPPED
ALTERNATING RED/GREEN (2.0Hz)	TEST MODE

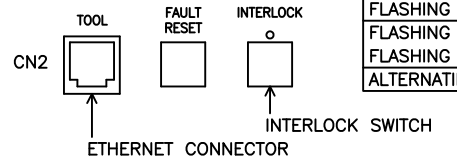

YORK INTERNATIONAL CORPORATION
YORK, PA .17405

DIMENSIONS ARE IN INCHES DO NOT SCALE TOLERANCES PER ENG. STD. M-282 WELDING PER ENG. STD. M-30 REF. DWG.		PCB (2) INTERCONNECTION	MATERIAL TYPE _____ ENG. STD. _____ PART NO. _____ CUT SIZE _____
DR. _____ APPR. _____ SCALE: _____	NAME _____ DATE _____ SIZE D CAGE NO _____	DRAWING NUMBER 1808JD17	
WT. = _____ LBS.		ORIG. NO. _____	SHEET 10 of 15

ALL PROPRIETARY RIGHTS IN THE SUBJECT MATTER HEREOF ARE RESERVED, AND NO PERMISSION IS GRANTED TO REPRODUCE THIS PRINT IN WHOLE OR IN PART, OR DISCLOSE ANY OF THE INFORMATION UPON IT TO OTHERS WITHOUT WRITTEN RELEASE BY YORK INTERNATIONAL CORPORATION.

REV. LEV.	DATE	REVISION RECORD	CHG. NO.	DR.	CK.	REV. LEV.	DATE	REVISION RECORD	CHG. NO.	DR.	CK.	REV. LEV.	DATE	REVISION RECORD	CHG. NO.	DR.	CK.
6						13						20					
5						12						19					
4						11						18					
3						10						17					
2						9						16					
1	06/05/14	UPGRADD TO ACE FORMAT		JO	AL	8						15					
0	04/28/06	FIRST ISSUE		OB	AL	7						14					

XIO JUMPER SETTINGS			
JUMPER	EXPLANATION	SILKSCREEN	SETTING
JP3	Pulse Generator (PG) power supply level selection. "P15" = +15VDC power supply "P5" = +5VDC power supply	PT5	1-2
		P5	2-3
		PT	2-3
JP4	Motor temperature sensor type selection. External transducer required when using 100 ohm sensor. "PT" = 1k ohm platinum motor temperature sensor "RTD" = 100 ohm platinum motor temperature sensor	PT	2-3
		RTD	1-2

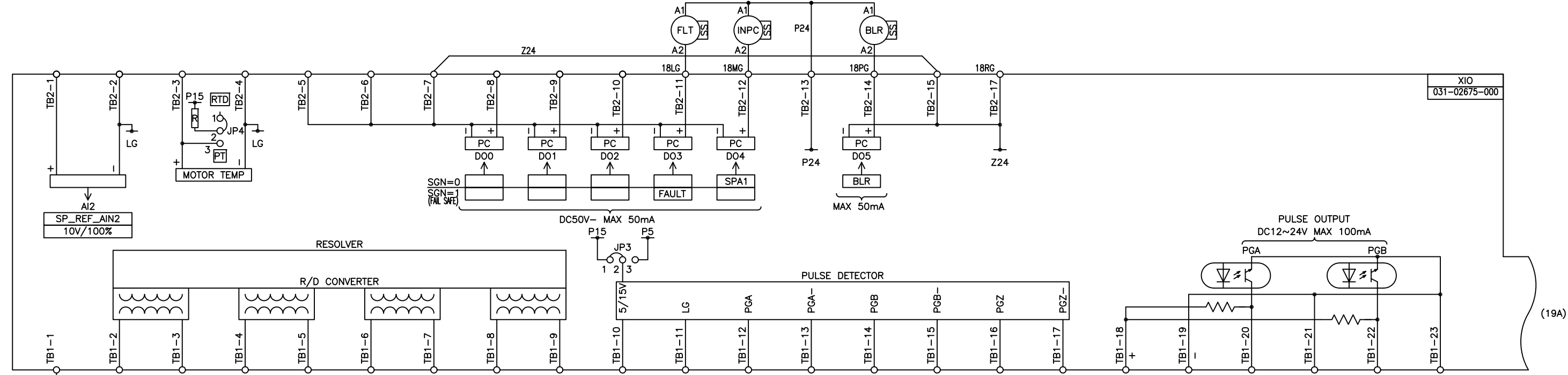
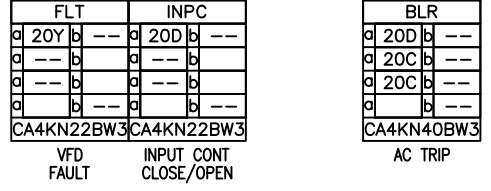

YORK INTERNATIONAL CORPORATION
YORK, PA .17405

REV. LEV.	DATE	REVISION RECORD	CHG. NO.	DR.	CK.	REV. LEV.	DATE	REVISION RECORD	CHG. NO.	DR.	CK.	REV. LEV.	DATE	REVISION RECORD	CHG. NO.	DR.	CK.
6						13						20					
5						12						19					
4						11						18					
3						10						17					
2						9						16					
1	06/05/14	UPGRADE TO ACE FORMAT		JO	AL	8						15					
0	10/22/2014	FIRST ISSUE		JO	AL	7						14					

"ALL PROPRIETARY RIGHTS IN THE SUBJECT MATTER HEREOF ARE RESERVED, AND NO PERMISSION IS GRANTED TO REPRODUCE THIS PRINT IN WHOLE OR IN PART, OR DISCLOSE ANY OF THE INFORMATION UPON IT TO OTHERS WITHOUT WRITTEN RELEASE BY YORK INTERNATIONAL CORPORATION."

DIMENSIONS ARE IN INCHES DO NOT SCALE TOLERANCES PER ENG. STD. M-282 WELDING PER ENG. STD. M-30 REF. DWG.		EXTERNAL I/O (1)		MATERIAL TYPE _____ ENG. STD. _____ PART NO. _____ CUT SIZE _____	
DR. _____	DATE _____	SIZE D	CAGE NO. _____	DRAWING NUMBER 1808JD18	
APPR. _____	SCALE: _____	WT. = _____	LBS. _____	ORIG. NO. _____	SHEET 11 of 15

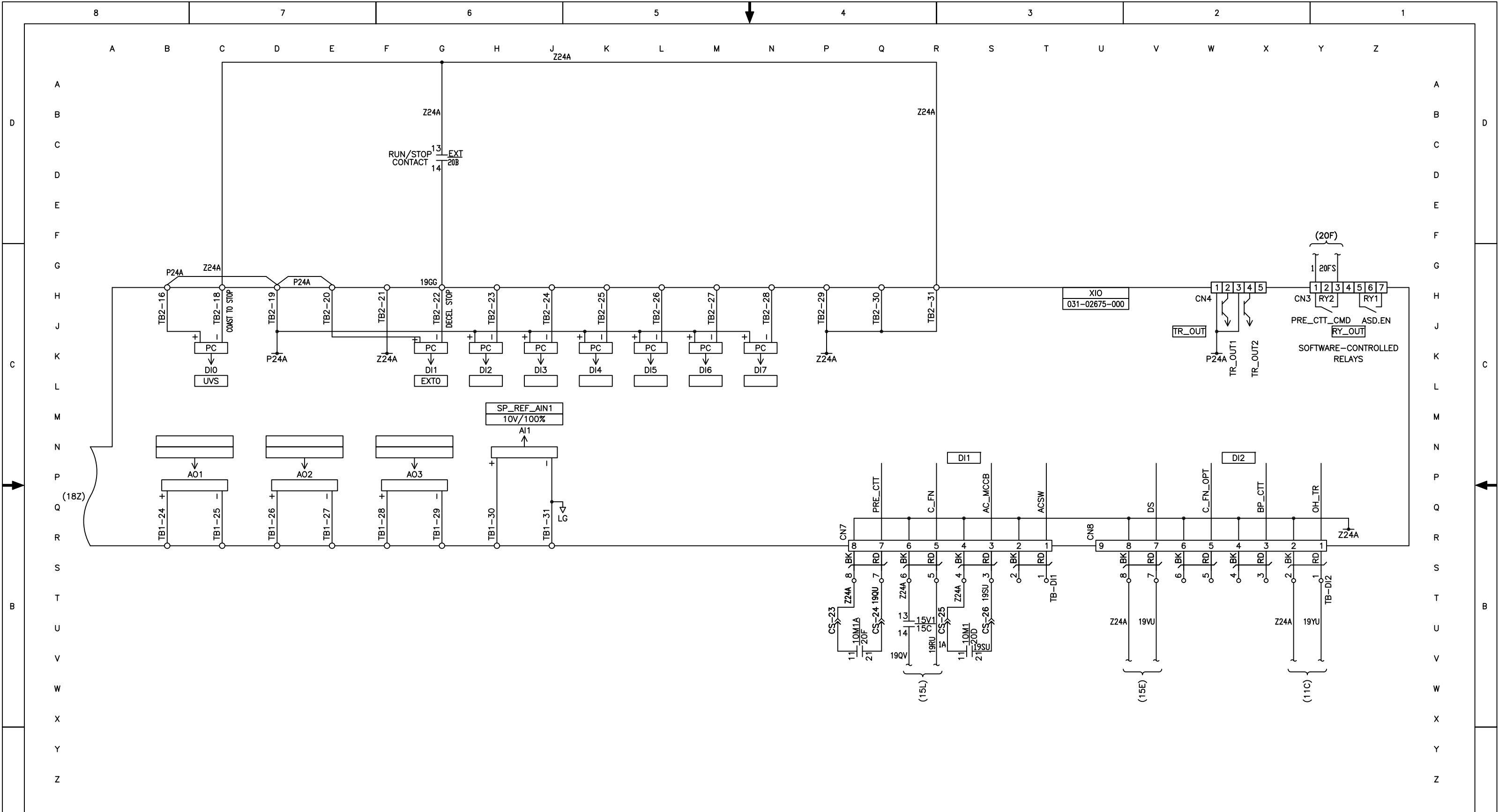

YORK INTERNATIONAL CORPORATION YORK, PA . 17405											
DIMENSIONS ARE IN INCHES DO NOT SCALE TOLERANCES PER ENG. STD. M-282 WELDING PER ENG. STD. M-30 REF. DWG.				EXTERNAL I/O (2)				MATERIAL TYPE _____ ENG. STD. _____ PART NO. _____ CUT SIZE _____			
DR. _____		DATE _____		SIZE D		CAGE NO _____		DRAWING NUMBER 1808JD19			
APPR. _____		SCALE _____		WT. = _____ LBS.		ORIG. NO. _____		SHEET 12 of 15			

REV. LEV.	DATE	REVISION RECORD	CHG. NO.	DR.	CK.	REV. LEV.	DATE	REVISION RECORD	CHG. NO.	DR.	CK.	REV. LEV.	DATE	REVISION RECORD	CHG. NO.	DR.	CK.
6						13						20					
5						12						19					
4						11						18					
3						10						17					
2						9						16					
1	06/05/14	UPGRADED TO ACE FORMAT		JO	AL	8						15					
0	04/20/06	FIRST ISSUE		OB	AL	7						14					

ALL PROPRIETARY RIGHTS IN THE SUBJECT MATTER HEREOF ARE RESERVED, AND NO PERMISSION IS GRANTED TO REPRODUCE THIS PRINT IN WHOLE OR IN PART, OR DISCLOSE ANY OF THE INFORMATION UPON IT TO OTHERS WITHOUT WRITTEN RELEASE BY YORK INTERNATIONAL CORPORATION.

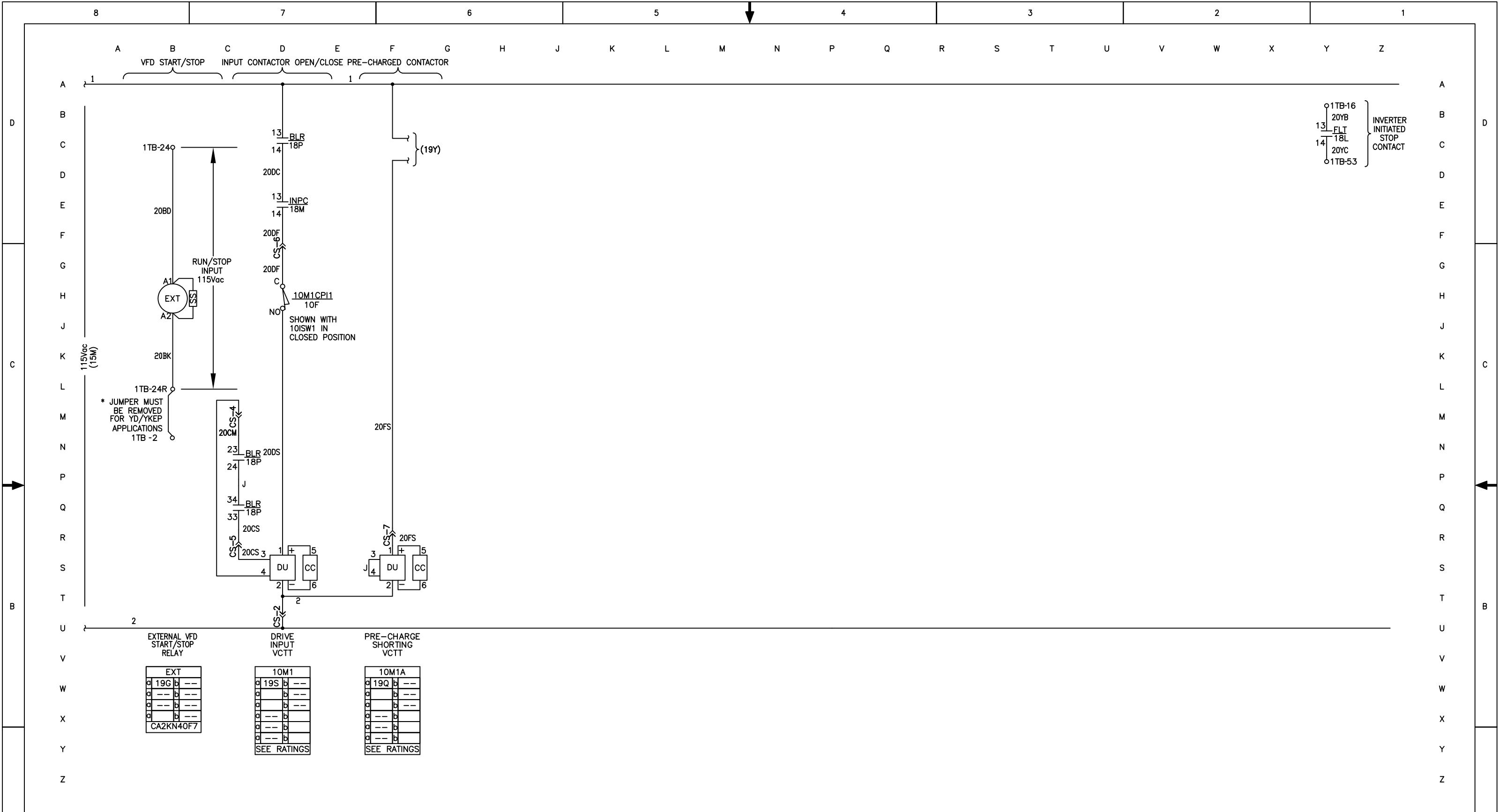

* Should be a label in the drive adjacent to the jumper. ?"JUMPER BETWEEN 2 AND 24R MUST BE REMOVED FOR YD/YKEP APPLICATIONS"

YORK INTERNATIONAL CORPORATION
YORK, PA .17405

DIMENSIONS ARE IN INCHES DO NOT SCALE TOLERANCES PER ENG. STD. M-282 WELDING PER ENG. STD. M-30 REF. DWG.		CONTROL CIRCUIT		MATERIAL TYPE _____ ENG. STD. _____ PART NO. _____ CUT SIZE _____	
DR. _____ APPR. _____ SCALE: _____	NAME _____ DATE _____	SIZE D	CAGE NO. _____	DRAWING NUMBER 1808JD20	
WT. = _____ LBS.		ORIG. NO. _____		SHEET 13 of 15	

REV. LEV.	DATE	REVISION RECORD	CHG. NO.	DR.	CK.	REV. LEV.	DATE	REVISION RECORD	CHG. NO.	DR.	CK.	REV. LEV.	DATE	REVISION RECORD	CHG. NO.	DR.	CK.
6						13						20					
5						12						19					
4						11						18					
3	06/20/16	ADDED JUMPER AND 1TB-24R		JAT	AL	10						17					
2	11/12/15	REVISED WIRETAG		RG	JO	9						16					
1	06/16/14	UPGRADED TO ACE FORMAT		JO	AL	8						15					
0	04/20/06	FIRST ISSUE		OB	AL	7						14					

*ALL PROPRIETARY RIGHTS IN THE SUBJECT MATTER HEREOF ARE RESERVED, AND NO PERMISSION IS GRANTED TO REPRODUCE THIS PRINT IN WHOLE OR IN PART, OR DISCLOSE ANY OF THE INFORMATION UPON IT TO OTHERS WITHOUT WRITTEN RELEASE BY YORK INTERNATIONAL CORPORATION.

CHILLER SYSTEM INTERFACE

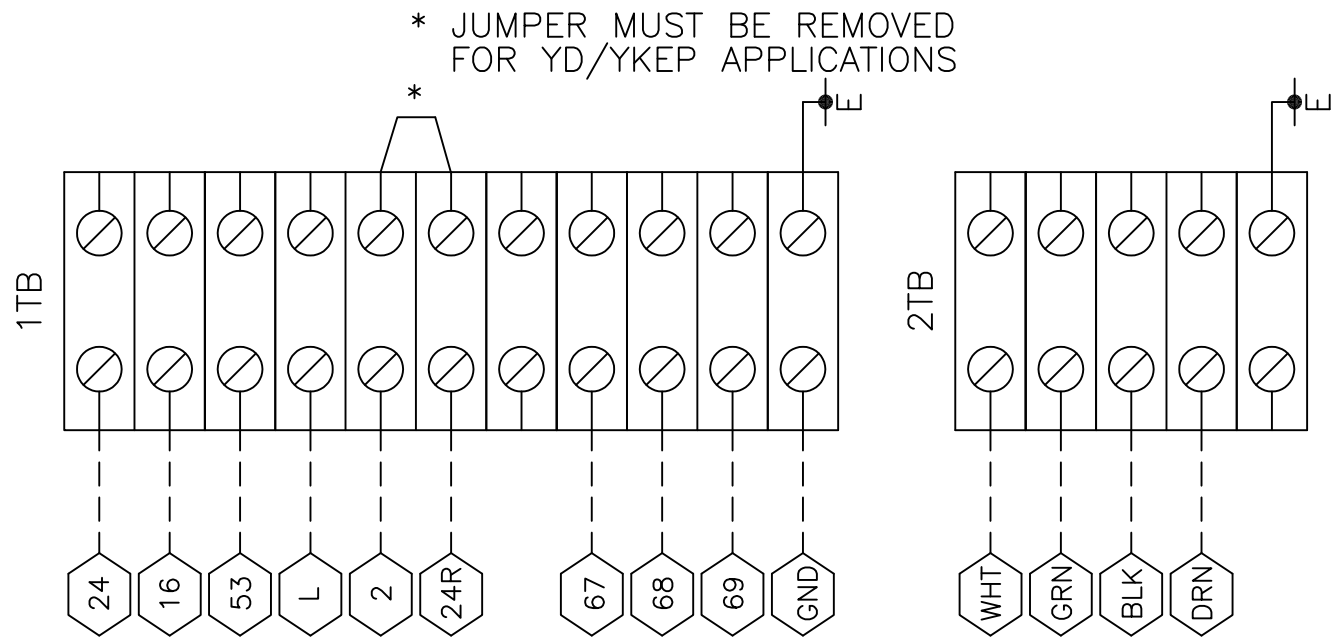

* Should be a label in the drive adjacent to the jumper. ?"JUMPER BETWEEN 2 AND 24R MUST BE REMOVED FOR YD/YKEP APPLICATIONS"

CUSTOMER TERMINAL BLOCK

REV. LEV.	DATE	REVISION RECORD	CHG. NO.	DR.	CK.	REV. LEV.	DATE	REVISION RECORD	CHG. NO.	DR.	CK.	REV. LEV.	DATE	REVISION RECORD	CHG. NO.	DR.	CK.
6						13						20					
5						12						19					
4						11						18					
3	04/20/16	CHANGED 1TB-GND TO 1TB-24R		JAT	AL	10						17					
2	06/16/14	UPGRADED TO ACE FORMAT		JO	AL	9						16					
1	12/15/08	REMOVED 2TB JUMPER		OB	AL	8						15					
0	04/20/06	FIRST ISSUE		OB	AL	7						14					

ALL PROPRIETARY RIGHTS IN THE SUBJECT MATTER HEREOF ARE RESERVED, AND NO PERMISSION IS GRANTED TO REPRODUCE THIS PRINT IN WHOLE OR IN PART, OR DISCLOSE ANY OF THE INFORMATION UPON IT TO OTHERS WITHOUT WRITTEN RELEASE BY YORK INTERNATIONAL CORPORATION.

YORK INTERNATIONAL CORPORATION YORK, PA . 17405			
DIMENSIONS ARE IN INCHES DO NOT SCALE TOLERANCES PER ENG. STD. M-282 WELDING PER ENG. STD. M-30 REF. DWG.	CHILLER SYSTEM TERMINAL CONNECTIONS	MATERIAL TYPE _____ ENG. STD. _____ PART NO. _____ CUT SIZE _____	
DR. _____ APPR. _____ SCALE: _____	NAME _____ DATE _____ SIZE D	CAGE NO. _____ ORIG. NO. _____	DRAWING NUMBER 1808JD28
WT. = _____ LBS.	SHEET 14 of 15		

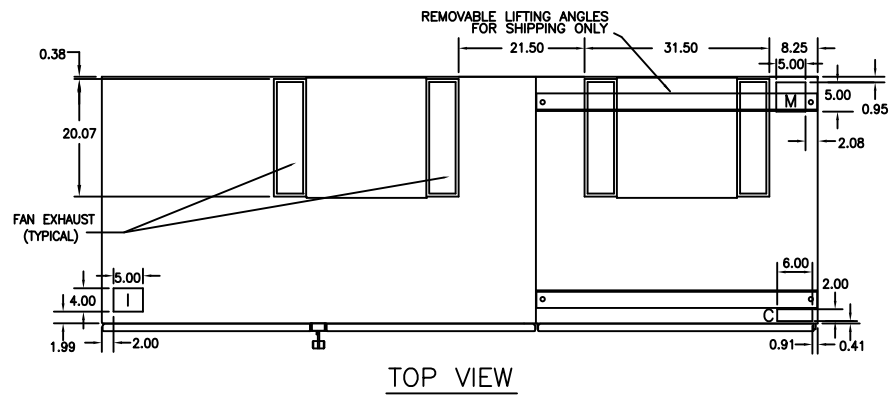

TOP VIEW

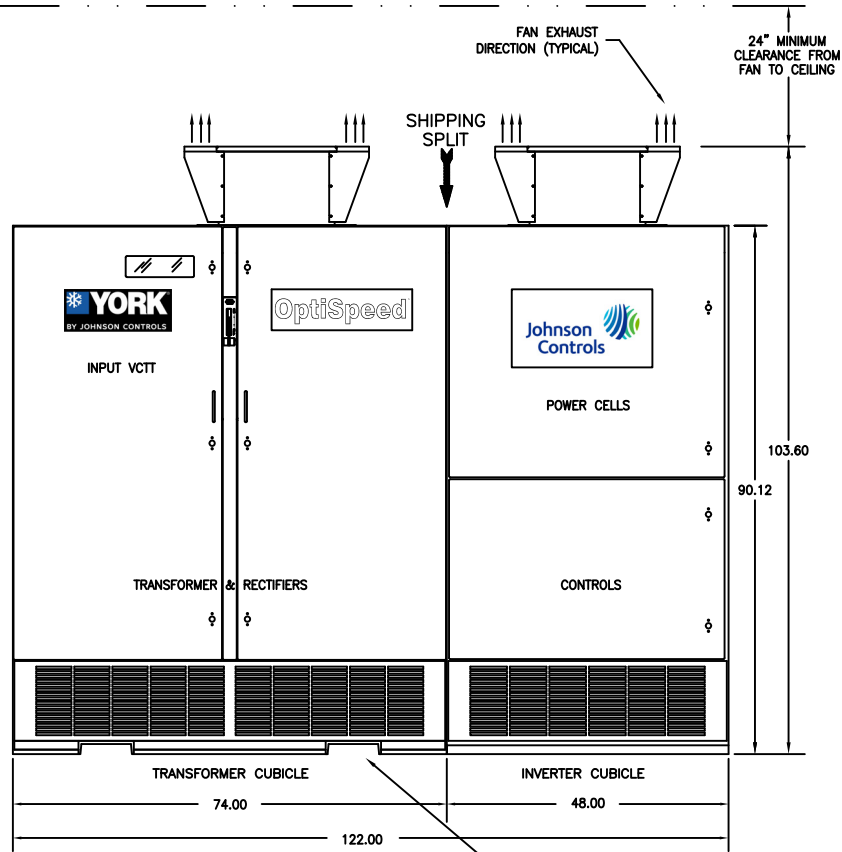

FRONT VIEW

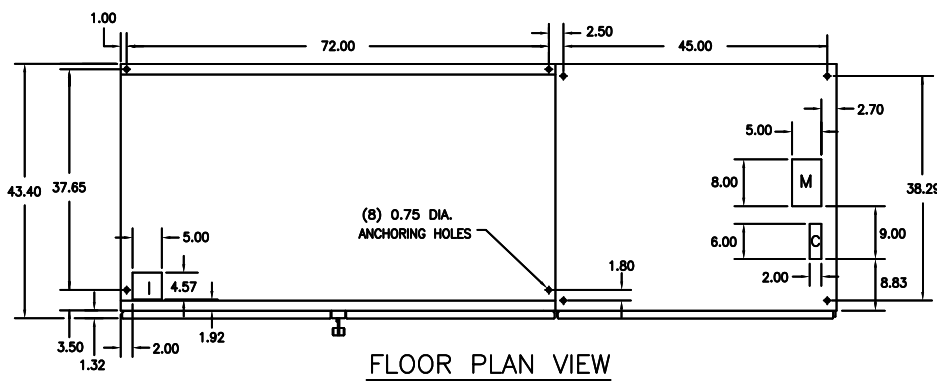

FLOOR PLAN VIEW

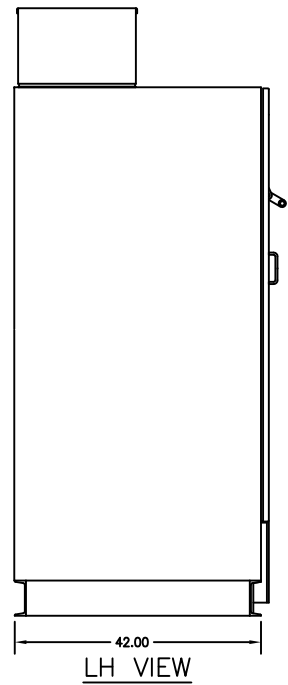
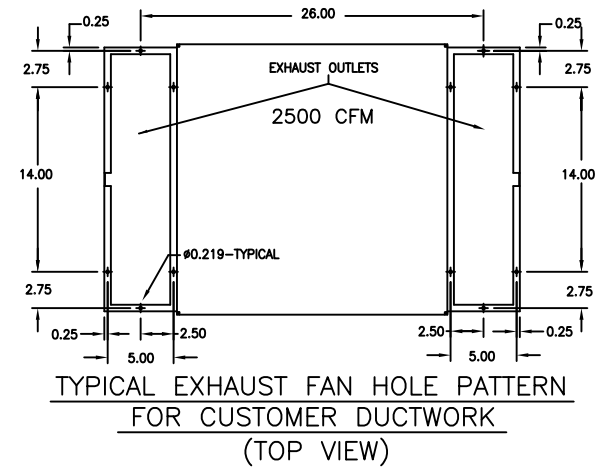

LH VIEW

CABLE TERMINATIONS			
ENTRY	INCOMING CABLES	MOTOR LEADS	CONTROL WIRE
TOP	I	M	C
BOTTOM	I	M	C

INCOMING TERMINATIONS USE NEMA 4-HOLE PATTERN
MOTOR TERMINATIONS USE NEMA 4-HOLE PATTERN

- NOTES**
- ENCLOSURE TYPE: NEMA 1 W/GASKETED DOORS
 - ALL WEIGHTS ARE APPROXIMATE
 - ALL DIMS ARE IN INCHES
 - POWER CELLS NEED TO BE REMOVED FOR ACCESS

	1000HP	1250HP	1500HP	1750HP	2000HP
TRANSFORMER CUBICLE	6,500 lbs	7,700 lbs	8,500 lbs	9,400 lbs	10,000 lbs
INVERTER CUBICLE	2,500 lbs	2,500 lbs	2,500 lbs	2,500 lbs	2,500 lbs

REV. LEV.	DATE	REVISION RECORD	CHG. NO.	DR.	CK.	REV. LEV.	DATE	REVISION RECORD	CHG. NO.	DR.	CK.	REV. LEV.	DATE	REVISION RECORD	CHG. NO.	DR.	CK.
6						13						20					
5						12						19					
4						11						18					
3						10						17					
2						9						16					
1	07/22/10	LABEL CHANGE		XZ	AL	8						15					
0	04/20/06	FIRST ISSUE		OB	AL	7						14					

*ALL PROPRIETARY RIGHTS IN THE SUBJECT MATTER HEREOF ARE RESERVED, AND NO PERMISSION IS GRANTED TO REPRODUCE THIS PRINT IN WHOLE OR IN PART, OR DISCLOSE ANY OF THE INFORMATION UPON IT TO OTHERS WITHOUT WRITTEN RELEASE BY YORK INTERNATIONAL CORPORATION.

YORK INTERNATIONAL CORPORATION
YORK, PA . 17405

DIMENSIONS ARE IN INCHES DO NOT SCALE TOLERANCES PER ENG. STD. M-282 WELDING PER ENG. STD. M-30 REF. DWG.		OUTLINE ENCLOSURE		MATERIAL TYPE _____ ENG. STD. _____ PART NO. _____ CUT SIZE _____
DR. _____	DATE _____	SIZE D	CAGE NO. _____	DRAWING NUMBER 1808JD30
APPR. _____	SCALE: _____	WT. = _____ LBS.	ORIG. NO. _____	SHEET 15 of 15