

| | | |
|--|--|----------------------|
|  BY JOHNSON CONTROLS | MEDIUM VOLTAGE VARIABLE SPEED DRIVE | |
| SERVICE INSTRUCTION | NEW RELEASE | Form 160.00-M9 (914) |

**POWER RELIABILITY OPTION
(CATCH A SPINNING LOAD)
FIELD MODIFICATION PROCEDURE**



LD14421

Issue Date:
September 30, 2014



IMPORTANT!

READ BEFORE PROCEEDING!

GENERAL SAFETY GUIDELINES

This equipment is a relatively complicated apparatus. During installation, operation maintenance or service, individuals may be exposed to certain components or conditions including, but not limited to: refrigerants, materials under pressure, rotating components, and both high and low voltage. Each of these items has the potential, if misused or handled improperly, to cause bodily injury or death. It is the obligation and responsibility of operating/service personnel to identify and recognize these inherent hazards, protect themselves, and proceed safely in completing their tasks. Failure to comply with any of these requirements could result in serious damage to the equipment and the property in

which it is situated, as well as severe personal injury or death to themselves and people at the site.

This document is intended for use by owner-authorized operating/service personnel. It is expected that these individuals possess independent training that will enable them to perform their assigned tasks properly and safely. It is essential that, prior to performing any task on this equipment, this individual shall have read and understood this document and any referenced materials. This individual shall also be familiar with and comply with all applicable governmental standards and regulations pertaining to the task in question.

SAFETY SYMBOLS

The following symbols are used in this document to alert the reader to specific situations:



Indicates a possible hazardous situation which will result in death or serious injury if proper care is not taken.



Identifies a hazard which could lead to damage to the machine, damage to other equipment and/or environmental pollution if proper care is not taken or instructions are not followed.



Indicates a potentially hazardous situation which will result in possible injuries or damage to equipment if proper care is not taken.

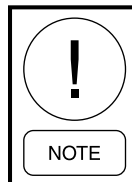

Highlights additional information useful to the technician in completing the work being performed properly.



External wiring, unless specified as an optional connection in the manufacturer's product line, is not to be connected inside the control cabinet. Devices such as relays, switches, transducers and controls and any external wiring must not be installed inside the micro panel. All wiring must be in accordance with Johnson Controls' published specifications and must be performed only by a qualified electrician. Johnson Controls will NOT be responsible for damage/problems resulting from improper connections to the controls or application of improper control signals. Failure to follow this warning will void the manufacturer's warranty and cause serious damage to property or personal injury.

CHANGEABILITY OF THIS DOCUMENT

In complying with Johnson Controls' policy for continuous product improvement, the information contained in this document is subject to change without notice. Johnson Controls makes no commitment to update or provide current information automatically to the manual owner. Updated manuals, if applicable, can be obtained by contacting the nearest Johnson Controls Service office or accessing the Johnson Controls QuickLIT website at <http://cgproducts.johnsoncontrols.com>.

Operating/service personnel maintain responsibility for the applicability of these documents to the equipment. If there is any question regarding the applicability of

these documents, the technician should verify whether the equipment has been modified and if current literature is available from the owner of the equipment prior to performing any work on the chiller.

CHANGE BARS

Revisions made to this document are indicated with a line along the left or right hand column in the area the revision was made. These revisions are to technical information and any other changes in spelling, grammar or formatting are not included.

LIST OF FIGURES

| | |
|--|----|
| FIGURE 1 - MV-VSD with UPS | 6 |
| FIGURE 2 - Installation Showing CASL UPS Cabinet located below the Optiview Control Panel | 7 |
| FIGURE 3 - CASL UPS Cabinet..... | 7 |
| FIGURE 4 - Electrical Connections | 8 |
| FIGURE 5 - “27” Relay and “PCTT” Relay Added to Terminal Rail | 9 |
| FIGURE 6 - Wiring of Coils on Added 27 and PCTT Relays | 9 |
| FIGURE 7 - Two NO Contacts on the PCTT Relay are Wired in Series | 10 |
| FIGURE 8 - The 13/14 NO Contact on Relay 27 is Wired Parallel to 10M1 Aux Contacts | 11 |
| FIGURE 9 - 120 VAC from the UPS to Terminal “L” Must Feed ONLY the Line Side of 15MCB2 – nothing else! .. | 11 |
| FIGURE 10 - Terminal Strip and UPS Feeding | 12 |
| FIGURE 11 - UPS Voltage Selection..... | 13 |
| FIGURE 12 - UPS Device | 13 |
| FIGURE 13 - Security Screen | 14 |
| FIGURE 14 - Home Screen..... | 14 |
| FIGURE 15 - Front Panel Selector Switch | 14 |
| FIGURE 16 - Motor Screen with CASL Enabled | 15 |
| FIGURE 17 - The MV-VSD Power Fault Recovery Screen..... | 15 |
| FIGURE 18 - Motor Screen Showing Power Fault Option Enabled | 16 |
| FIGURE 19 - Cable and Switch Wired in Series with Signal to PDM Board | 17 |

UPS CASL FIELD MODIFICATION PROCEDURE

CONCEPT

Losses of power lasting up to 10 seconds now have little impact on a YK chiller's ability to continue producing chilled water. JCI's new "Catch A Spinning Load" (CASL) option for YK Chillers with MV-VSD is a unique feature allowing the chiller to coast during a power interruption, enabling the chiller to resume cooling as soon as sufficient power is restored. This occurs even if the motor and compressor have reversed direction following a power loss or brown out. This feature is made possible by addition of a large Uninterruptible Power Supply (UPS) along with special software in the drive which is capable of identifying the speed and direction of the chiller motor at any given time. This system accelerates the motor back up to required speed, and in the proper direction, as soon as sufficient energy is available.

The hardware portion of this new feature requires the addition of a 6 kVA UPS device which becomes the source of 120 VAC to supply the logic in the MV-VSD, as well as the source of power for the Optiview chiller control panel. In addition, this UPS supplies 240 VAC which is stepped up to 480 VAC and then rectified to supply a constant source of DC bus voltage for the chiller's Variable Speed Oil Pump (VSOP). Therefore constant lubrication is maintained while the motor and compressor are coasting. *Figure 1 on page 6* is an illustration depicting this additional hardware.

SAFETY

This procedure should only be performed by a qualified technician certified in Medium Voltage Drive operation and maintenance. It is important that this instruction be read completely before starting the installation process.

In order to safely install the UPS, shutdown the chiller and remove incoming MV power to MV-VSD unit. Open the input power isolation switch and lock it out. Observe all normally required safety procedures.



The Control/VSD Cabinet contains lethal High AC and DC voltages. Before performing service inside the cabinet, remove the AC supply feeding the chiller and verify using a non-contact voltage sensor.

The DC Voltage on the VSD DC Bus will take 15 minutes to bleed off, after AC power is removed. Always check the DC Bus Voltage with a Voltmeter to assure the capacitor charge has bled off before working on the system.

- NEVER short out the DC Bus to discharge the filter capacitors.
- NEVER place loose tools, debris, or any objects inside the Control Panel/VSD Cabinet.
- NEVER allow the Control Panel VSD Cabinet doors to remain open if there is a potential for rain to enter the panel. Keep doors closed and assure all latches are engaged on each door unless the unit is being serviced.
- ALWAYS lockout the disconnect supplying AC to the chiller.

YK Chiller with Medium Voltage Variable Speed Drive and Power Reliability Option (Catch A Spinning Load)

- USA sourced YK Chiller may be ETL listed
- MVVSD is UL listed
- The UPS has UL listing, the UPS cabinet assembly does not have UL listing
- Cable and wire lengths vary by installation and configuration
- Refer to CASL Field Modification Procedure – 160.00-M9 for complete installation instructions

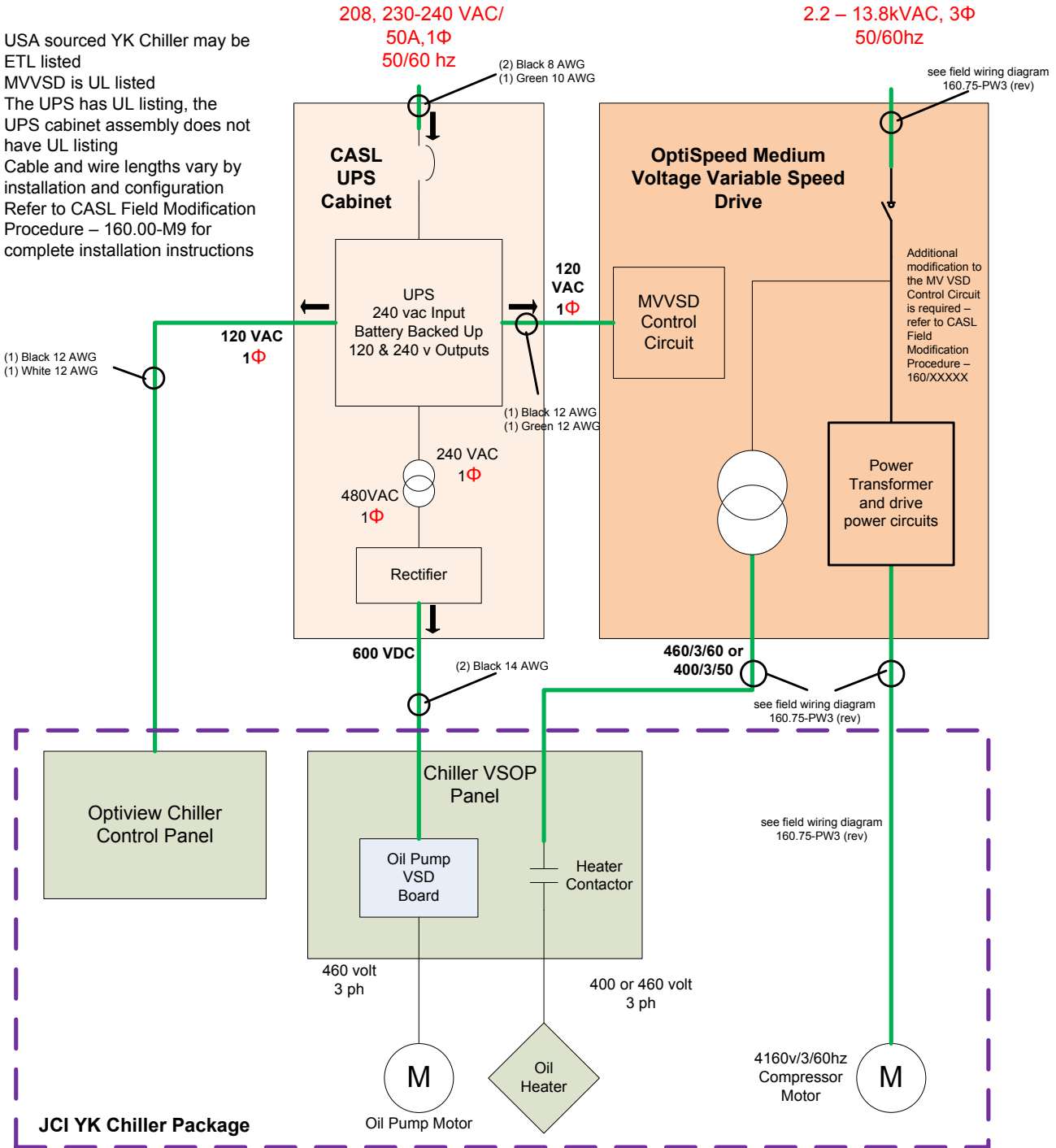

Refer to CASL Field Modification Procedure – 160.00-M9 for complete installation instructions

Red - Customer Supplied Voltage Source
Green - Field Wiring, Supplied by Others
Purple - JCI YK Chiller Package
 ← - Denotes connection from and to

KJE, Rev 1.1, 09/23/2014

FIGURE 1 - MV-VSD WITH UPS

Installing the CASL UPS Option Cabinet

1. Position the CASL UPS option cabinet close to the chiller and Optiview control panel.



LD18719

FIGURE 2 - INSTALLATION SHOWING CASL UPS CABINET LOCATED BELOW THE OPTIVIEW CONTROL PANEL

2. The CASL cabinet contains an Uninterruptible Power Supply (UPS) that contains batteries as shipped. Open the CASL cabinet by first removing the top cover. Then remove two bolts holding the front cover, and lift that cover up and out. Electrical connections are all made at the top, toward the rear of the cabinet. The UPS device has a hinged lower cover with magnetic latch which allows access to the internal batteries. There is also a keypad for setup of the UPS, and monitoring of its operation and history. At the top of the enclosure are components used to step up the 240 VAC to 480 VAC and to rectify that voltage to supply DC to the oil pump drive.

Figure 4 on page 8 shows a diagram of the electrical connections to be made between the additional CASL cabinet containing the UPS and the existing chiller and MV-VSD cabinets.

3. Connect the customer-supplied single phase 240 VAC/ 50 amp supply to the CASL cabinet. Use two black 8 AWG wires to make this connection. Also run one green 10 AWG (or larger) wire for the ground connection.



LD18720

FIGURE 3 - CASL UPS CABINET

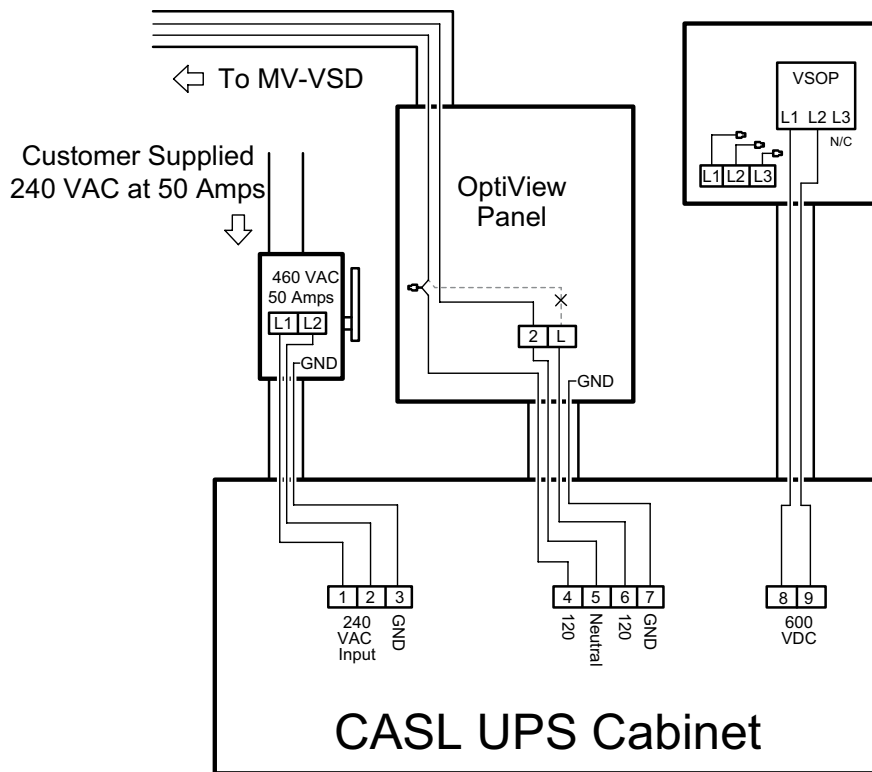

LD18764

FIGURE 4 - ELECTRICAL CONNECTIONS

4. Install flexible conduit or EMT from the CASL cabinet to the Oil Pump Enclosure on the chiller. Remove the existing wires from terminals L1, L2, and L3 on the variable speed oil pump (VSOP) drive, and cap these wires. Connect the CASL terminals #8 and #9 output of 600 VDC to the L1 and L2 terminals on the VSOP Drive, using two black 14 AWG wires. The polarity of these wires does not matter since this DC supply is passed through the input rectifier of the VSOP. The diodes in the rectifier automatically address the polarity of this supply.
5. Install a flexible conduit or EMT from the CASL cabinet to the Optiview panel enclosure. This conduit should contain four 12 gauge wires, as follows: one white, one green, and two black wires.
6. Normally the Optiview panel is powered by 120 VAC coming from the MV-VSD on wires “L” and “2”. The line-side “L” wire must be removed from terminal “L” on the Optiview terminal strip, and connected to the 120 VAC supply from terminal #4 in the CASL cabinet. The “L” and “2” wires between the Optiview panel and the MV-VSD are now used to supply 120 VAC to the MV-VSD logic, rather than receive 120 VAC from the MV-VSD.

7. Run a white neutral wire from terminal #5 in the CASL enclosure to terminal #2 in the Optiview. The existing #2 wire from the MV-VSD should remain on this terminal as this neutral is common to both the Optiview panel and the MV-VSD.
8. Run a black wire from terminal #6 in the CASL enclosure to terminal “L” in the Optiview panel. The UPS now becomes the source of 120 VAC for the Optiview panel.

Wiring Modifications to MV-VSD

1. It is necessary to add two additional control relays (relay 27, and relay PCTT as shown in *Figure 5 on page 9*) in the MV-VSD logic enclosure. In most cases it is possible to slide the existing wiring interface terminal strips to the left end of the existing rail on the bottom of the cabinet, making room to add these two relays to this rail. See photo.
2. All wiring to these relays may utilize black 16 AWG wire (or larger).
3. Connect +24 VDC to the A1 (+) coil terminals of both the 27 and PCTT relays by running a wire to the A1 (+) terminal of the INPC relay and to the A1(+) terminals of each relay.

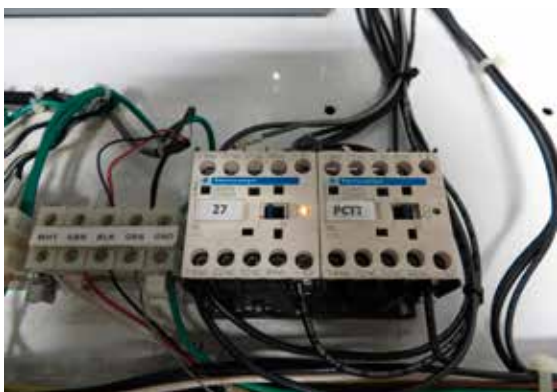

LD18722

FIGURE 5 - "27" RELAY AND "PCTT" RELAY ADDED TO TERMINAL RAIL

4. On the 27 relay A2 (-) coil terminal, run a wire to terminal TB2-10 on the I/O board as shown in *Figure 6 on page 9*.
5. Cut both wires connected to CN3 on the I/O board, and cap the ends of the wires from the harness. Attach butt-splices to the ends of the wires attached to the CN3 connector.

6. On the PCTT relay A2 (-) coil terminal, run a wire to the butt-splice at connector CN3, pin 3 on the I/O board.
7. Run a wire from the other butt-splice on CN3, pin 1 to Z24 (-24 VDC) at terminal TB2-30.
8. Locate the 10M1A Pre-Charge Contactor assembly (behind main contactor) in the transformer cabinet, and remove the jumper wire from terminal 3 to terminal 4 on the terminal strip on this contactor.
9. Attached a pair of black 16 gauge wires to terminals 3 and 4, and route this pair of wires through the cabinet to the logic section of the drive. Secure the wires to the framework inside the transformer section using wire-ties.
10. Remove the existing wire to terminal 1 on the 10M1A Pre-Charge contactor, cap this wire, and run a new wire from terminal 1 to the terminal 1 on the adjacent 10M1 Main Input contactor.

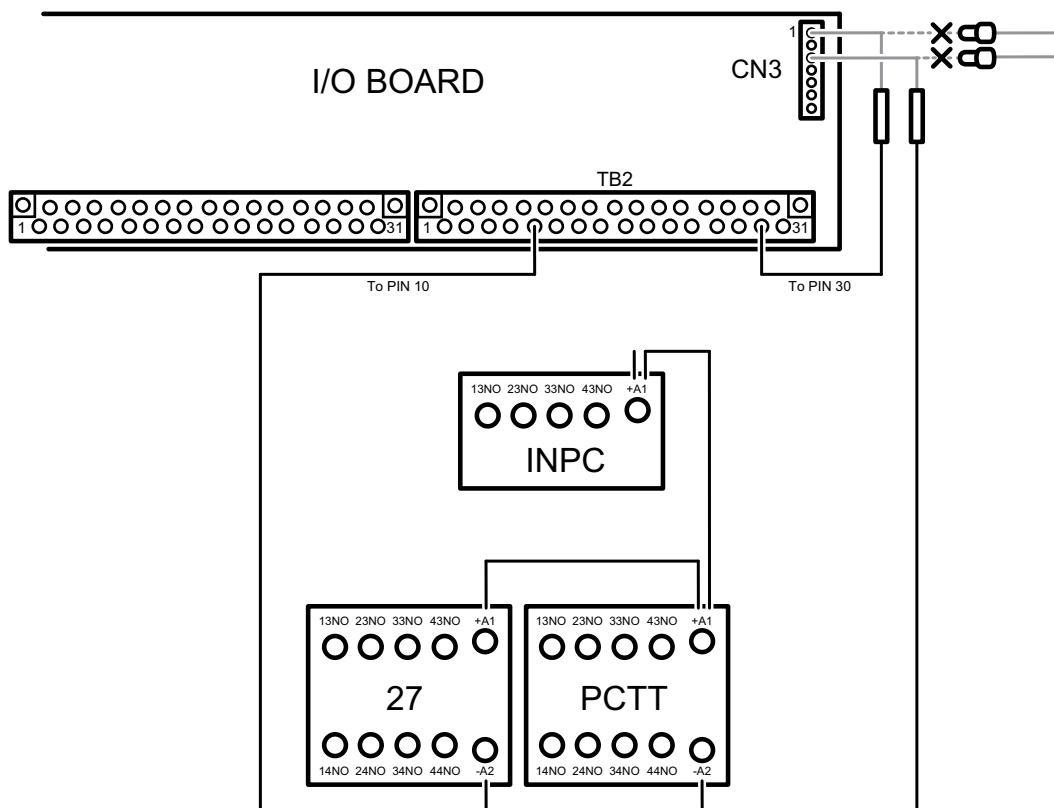

LD18766

FIGURE 6 - WIRING OF COILS ON ADDED 27 AND PCTT RELAYS

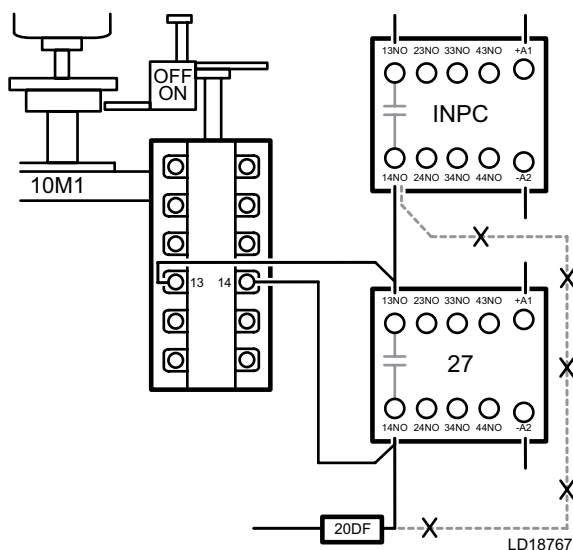

FIGURE 8 - THE 13/14 NO CONTACT ON RELAY 27 IS WIRED PARALLEL TO 10M1 AUX CONTACTS

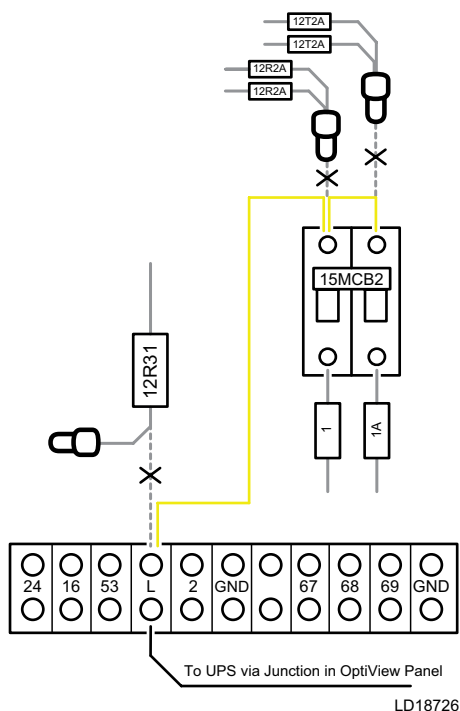

FIGURE 9 - 120 VAC FROM THE UPS TO TERMINAL "L" MUST FEED ONLY THE LINE SIDE OF 15MCB2 – NOTHING ELSE!

Software Required for MV-VSD and Optiview Panel

1. To function as a CASL drive, the MV-VSD must have firmware of version A3TF090 or later.
2. The MV-VSD also requires a special set-file program with additional features.
3. The Optiview panel requires version 26 or later YK software to enable this feature.

Procedure for Flashing the MV-VSD Controller Board with A3TF090 Firmware

1. Dip Switch SW1-1 on the Modbus board must be set to "1" prior to powering.
2. Save a copy of the firmware A3TF09G0_Y061g_2E1E.hex to your desktop.
3. Make certain the laptop's LAN settings are set to "Automatically Detect Settings".
 - a. Go to "Start", "Control Panel", "Network and Internet", "Internet Options", and then click the tab marked "Connections".
 - b. Click the button for "LAN Settings".
 - c. Place a checkmark in the box in front of "Automatically Detect Settings". You may also have a second checkmark in front of the box for the normal JCI connection, <http://autoconfig.jci.com:8080/>.
4. Turn off all other network connections – no Bluetooth, no wireless, no other Ethernet!
5. Connect the laptop to the MV-VSD through the "Tool" port on the keypad.
6. With Windows 7 wait while the blue swirl goes around and around. You should eventually see a yellow triangle with an exclamation point inside, or a park bench if the communications window is open.
7. Launch HexWrite using the HexWriteE1-8B1.exe file found in the SubProgram folder of Wi tool, the path is typically C:\Toshiba\Wi Tool\SubProgram.
8. At the top of the HexWrite program window, you should see:

Port Select = UDP (Ethernet), Host Port = 5757,
 Target IP = 255.255.255.255 Target Port = 5757



LD18727a



LD18727b

FIGURE 10 - TERMINAL STRIP AND UPS FEEDING

9. In the lower half of the HewWrite window, click the “Read File” select box and browse to the file containing the firmware A3TF09G0_Y061g_2E1E.hex. The selected file must appear in the Read File drop down box in this lower half of the window.
10. Next click the box labeled “Step 2 Start”. There may be a delay of a few seconds.
11. A small window should open stating ChkSum = 2E:1E Continue? Click “Yes”.
12. The Target IP should be displayed as 192.168.87.87
13. Near the bottom of the HexWrite window you will see “Sending Packet”. Initially this should read C/0, and should begin incrementing until it reads 1043/1043. It may pause briefly at certain values, such as 139/1043. This might take a little longer than you would expect, but it will eventually finish. Do not interrupt during this step.
14. Upon completion of step #13, another small window should open stating “Complete”. Click the OK button. This completes the flashing process.
15. **VERY IMPORTANT !** - Cycle power to the controller board and wait for communications to re-establish between your laptop and the drive. If you do not cycle power, the firmware will not be updated.
16. Set the Dipswitch SW1-1 back to “0”.

Updating the MV-VSD Setfile to Include CASL Features

The setfile saved to the MV-VSD controller board must contain additional parameters for the CASL feature. The setfile must also contain the specific voltage, HP, and CT ratios, etc, for the specific voltage and HP drive. Therefore it is not possible to have one setfile which works in any MV-VSD having this feature. The setfile must contain all the specific data for the unique drive, plus all the CASL features. In most cases this setfile will be pre-loaded to the drive on new equipment orders, however for retrofits it will be necessary to have the factory modify the existing drive setfile to contain the additional CASL parameters. Once you have obtained a copy of this updated setfile, you will need to use a laptop PC and WiTool software to copy the setfile to drive Ram, and then copy it from Ram to Eeprom 0. If you do not copy it to Eeprom 0, the program will be lost the next time drive power is cycled.

Updating the Optiview Software

The Optiview software must be updated through the normal process using an appropriate flash-card. CASL features are supported in Optiview YK software version 26 and later.

Programming and Enabling the UPS

The Toshiba UPS inside the CASL cabinet has ability to be powered by either 208 VAC or 230/240 VAC single phase. However, an internal jumper must be set to match the available input voltage. For 208 VAC the jumper must be from terminal #11 to terminal #12 on the UPS device (not upper terminal strip). For 230/240

VAC the jumper must be from terminal #12 to terminal #13 on the UPS device.

The Toshiba UPS must also be programmed for the appropriate input and output voltages as well as set to operate in the On-Line mode by default. The display on the front of the UPS device is a touch sensitive screen. Tap the “Settings” tab on the screen. The screen will display several boxes with parameter categories as seen below:

By touching the “Input” box, the screen will display the input settings. By touching the “Output” box, the screen will display the output settings. Verify the following settings are correct by selecting the appropriate submenu and viewing the value adjacent to the setting parameter.

Input:

111 Rated Vin = 208 V (or 240 as appropriate)

Output:

215 Rated Vout = 240 V

216 Rated Iout = 25 A

Ctrl/Cfg:

640 Startup Mode = On-Line

641 Startup Delay = 0 Sec

If any of the settings are found to be incorrect, it will be necessary to change the security level in order to make the changes. This is done by touching the security key which is the padlock symbol with the letters “USR” next to it, located near the top of the screen. When this button is touched, the “619 Change Security Level” screen will appear. Change the letters in the box to ADMIN, using the telephone-type keypad, tapping each key multiple times to get the desired letter, then touch the “Write” button. You will now be able to change settings. Be certain to change the security level back to USER after the changes are made.

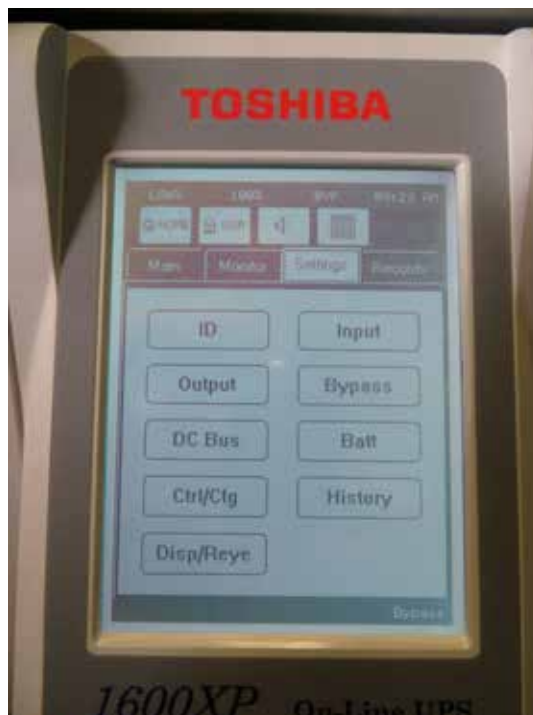

LD18729

FIGURE 12 - UPS DEVICE

208 Vin – Using provided jumper, connect terminals 11 – 12.

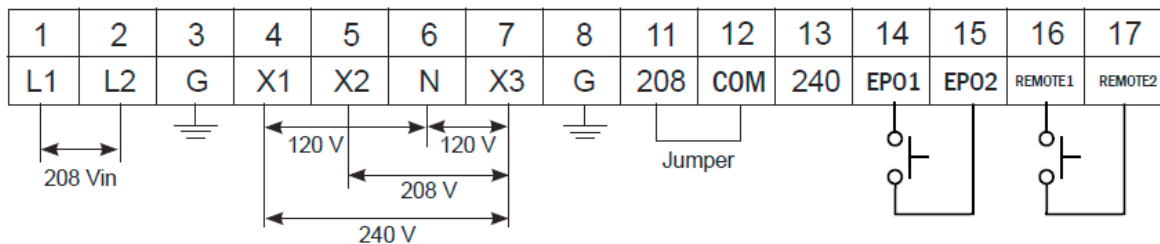

240 Vin – Using provided jumper, connect terminals 13 – 12.

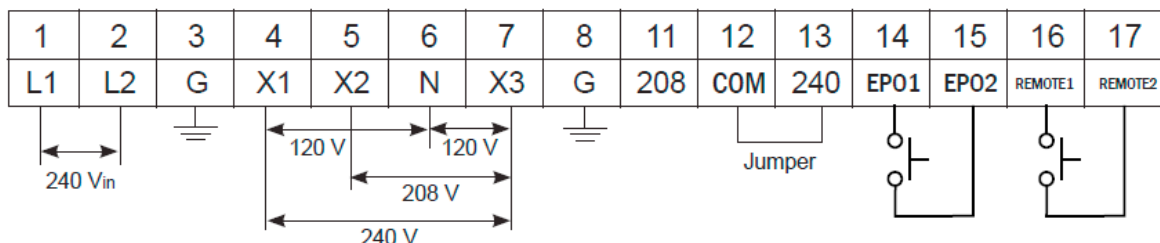

LD18728

FIGURE 11 - UPS VOLTAGE SELECTION

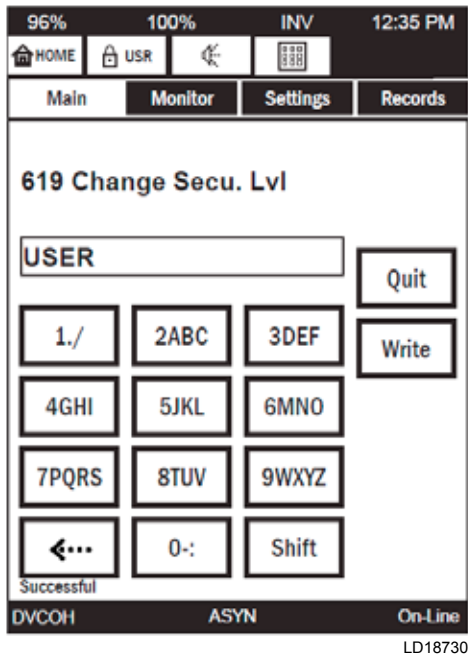

LD18730

FIGURE 13 - SECURITY SCREEN

Once all the UPS settings have been verified to be correct, and all wiring has been completed, the UPS may be enabled by moving the front panel selector switch from “Stop” to “Run”. Then go to the Home Screen on the UPS Keypad. Verify there is a dot in the box adjacent to RUN. If the dot shows up in the STOP box, press the RUN Button on the touch keypad until the dot is adjacent to RUN.



LD18730a

FIGURE 14 - HOME SCREEN

Enabling CASL Through the Optiview Panel

Optiview software of version 26 and later, automatically checks for the CASL feature when MV-VSD is selected as the starter type and the Optiview initializes communications with the MV-VSD. Data sent from the MV-VSD tells the Optiview panel whether the CASL feature is present. When CASL is detected, there are additional screens which may be viewed via the Optiview panel. *Figure 16 on page 15* is an example of the motor screen when CASL is enabled:



LD18731

FIGURE 15 - FRONT PANEL SELECTOR SWITCH

When the power fault recovery key is selected, it calls the power fault recovery screen as seen in *Figure 17 on page 15*, and as follows:

There is an LED on this screen which is illuminated when the Power Fault Control/CASL Control is active. Likewise two LEDs respond to signals from the MV-VSD whenever a power fault has been detected and/or the CASL feature is recovering the speed of the motor. Each time either LED is illuminated, the adjacent counter also increments.

In addition, there are settings to control how long the motor is allowed to be below the minimum speed threshold, as well as the CASL percent speed, which is the percentage of the normal speed command. These two values are adjustable only in the ADMIN mode, within the following ranges:



LD18732

Note the Power Fault Recovery Key along the right side of the screen

FIGURE 16 - MOTOR SCREEN WITH CASL ENABLED



LD18733

FIGURE 17 - THE MV-VSD POWER FAULT RECOVERY SCREEN

TABLE 1 - PROGRAM SETTINGS

| PROGRAM SETTING | SCREEN | MODE | LOW LIMIT | HIGH LIMIT | DEFAULT |
|------------------------------|---------------------------------|------|-----------|------------|---------|
| VSD Low Frequency Fault Time | Power Fault Recovery - Button 8 | * | 60 sec | 120 sec | 60 sec |
| CASL VSD Speed Percent | Power Fault Recovery - Button 9 | * | 80% | 100% | 93% |

This information can also be viewed as part of the history details screen in *Figure 18*:

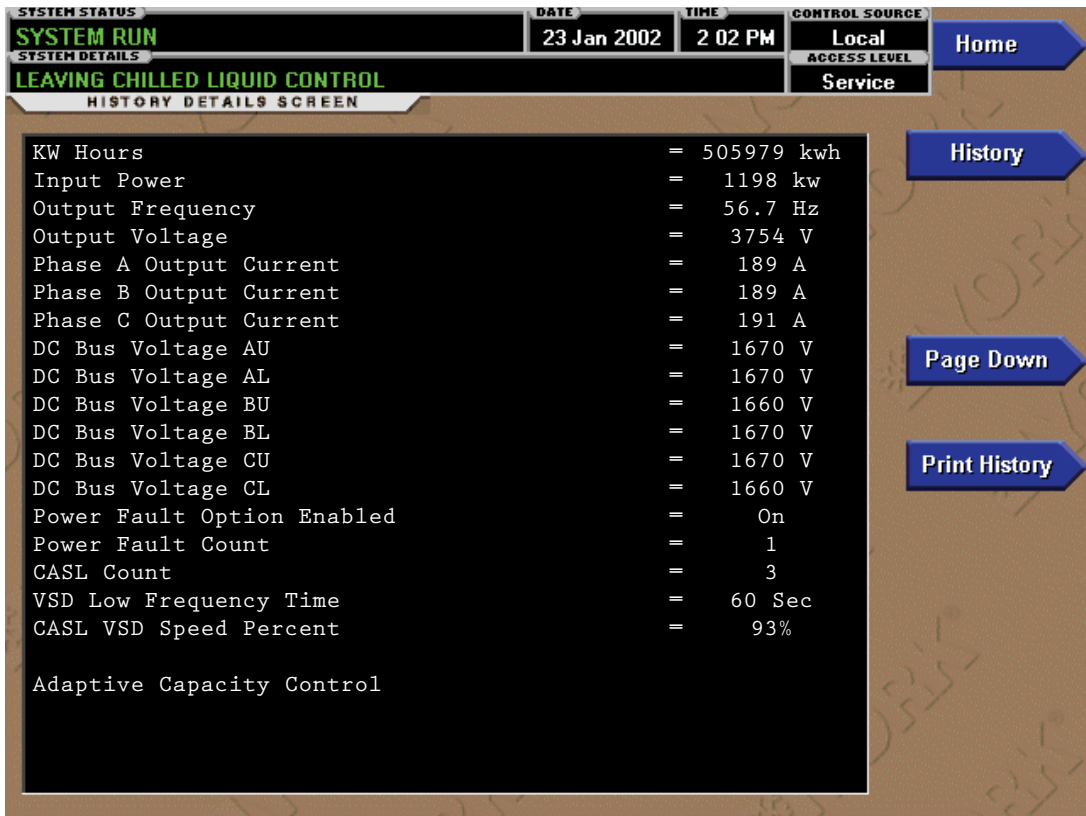

LD18769

FIGURE 18 - MOTOR SCREEN SHOWING POWER FAULT OPTION ENABLED

Testing the CASL Feature

Normally there is no need to make any adjustments to the CASL feature, and the feature operates automatically without any intervention. Should it become necessary to verify the operation of this CASL feature, this can be accomplished by simulating a power loss on one of the phases being monitored by the MV-VSD logic. This is most easily accomplished by wiring a switch in series with the 120 control power as sensed by the MV-VSD's PDM board. Wire 12T2A can be removed from terminal T3 on the PDM board, and an external switch wired in series with this wire and its normal connection at T3 on PDM. With the logic cabinet door closed and the chiller running, this switch contact can be manually opened for a period up to 10 seconds in duration. The chiller will respond as if there was a power loss on that phase and will recover as soon as the switch is re-closed, even if the motor has reversed direction by that time. If the head pressure on the machine is significant, the compressor may surge several times as it ramps up. However, it will ultimately overcome the pressure and return to normal speed.

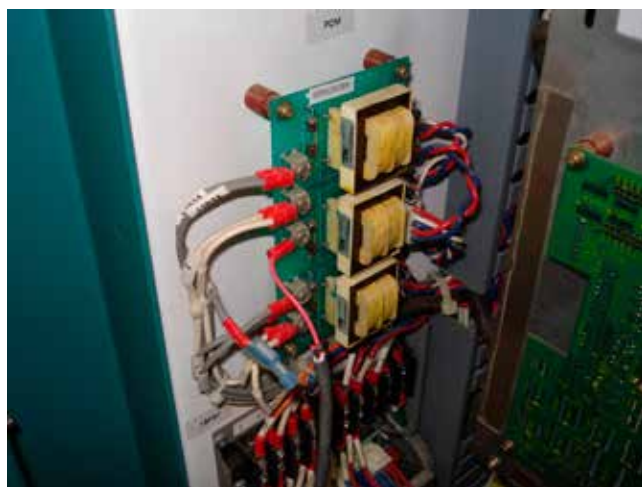

LD18735

FIGURE 19 - CABLE AND SWITCH WIRED IN SERIES WITH SIGNAL TO PDM BOARD



P.O. Box 1592, York, Pennsylvania USA 17405-1592
Copyright © by Johnson Controls 2014
Form 160.00-M9 (914)
Issue Date: September 30, 2014
New Release

800-861-1001
www.johnsoncontrols.com

Subject to change without notice. Printed in USA
ALL RIGHTS RESERVED