

 BY JOHNSON CONTROLS	<b>MEDIUM VOLTAGE VARIABLE SPEED DRIVE</b>	
SERVICE	NEW RELEASE	Form 160.00-M8 (810)

**MEDIUM VOLTAGE 500 - 2500 HP  
12,470V, 13,800v 60hz &  
10,000v, 11,000 50hz  
VARIABLE SPEED DRIVES for  
YK CHILLER APPLICATIONS**



LD14420

# IMPORTANT!

## READ BEFORE PROCEEDING!

### GENERAL SAFETY GUIDELINES

This equipment is a relatively complicated apparatus. During installation, operation maintenance or service, individuals may be exposed to certain components or conditions including, but not limited to: refrigerants, materials under pressure, rotating components, and both high and low voltage. Each of these items has the potential, if misused or handled improperly, to cause bodily injury or death. It is the obligation and responsibility of operating/service personnel to identify and recognize these inherent hazards, protect themselves, and proceed safely in completing their tasks. Failure to comply with any of these requirements could result in serious damage to the equipment and the property in

which it is situated, as well as severe personal injury or death to themselves and people at the site.

This document is intended for use by owner-authorized operating/service personnel. It is expected that this individual possesses independent training that will enable them to perform their assigned tasks properly and safely. It is essential that, prior to performing any task on this equipment, this individual shall have read and understood this document and any referenced materials. This individual shall also be familiar with and comply with all applicable governmental standards and regulations pertaining to the task in question.

---

## SAFETY SYMBOLS

The following symbols are used in this document to alert the reader to specific situations:



*Indicates a possible hazardous situation which will result in death or serious injury if not proper care is not taken.*

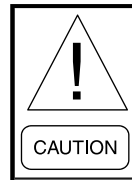

*Identifies a hazard which could lead to damage to the machine, damage to other equipment and/or environmental pollution if proper care is not taken or instructions and are not followed.*



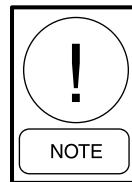

*Indicates a potentially hazardous situation which will result in possible injuries or damage to equipment if proper care is not taken.*





*Highlights additional information useful to the technician in completing the work being performed properly.*



*External wiring, unless specified as an optional connection in the manufacturer's product line, is not to be connected inside the OptiView cabinet. Devices such as relays, switches, transducers and controls and any external wiring must not be installed inside the micro panel. All wiring must be in accordance with Johnson Controls' published specifications and must be performed only by a qualified electrician. Johnson Controls will NOT be responsible for damage/problems resulting from improper connections to the controls or application of improper control signals. Failure to follow this warning will void the manufacturer's warranty and cause serious damage to property or personal injury.*

 <b>DANGER</b>	
DO NOT REMOVE, DESTROY OR COVER THIS LABEL	
DO NOT OPEN THIS DOOR WHILE THE UNIT IS RUNNING. THIS DOOR IS INTERLOCKED WITH EQUIPMENT OPERATION.	
	<b>HAZARDOUS VOLTAGE May Be Present</b>
	<ul style="list-style-type: none"><li>• Capacitors are Charged. Wait at Least 15 Minutes After Disconnecting Power Before Entry.</li><li>• Check For Charged Voltage to Dissipate To A Safe Level Before Working On Equipment.</li></ul>

 <b>DANGER</b>	
DO NOT REMOVE, DESTROY OR COVER THIS LABEL	
READ THE INSTRUCTION MANUAL CAREFULLY BEFORE INSTALLING, OPERATING OR SERVICING THIS EQUIPMENT.	
	<b>HAZARDOUS VOLTAGE Can Cause Severe Injury, Death, Fire, Explosion, and Property Damage</b>
	<ul style="list-style-type: none"><li>• Only Qualified Personnel Should Be Permitted To Operate Or Service This Equipment.</li><li>• Disconnect And Lock Out Primary And Control Circuit Power Before Servicing</li><li>• Keep All Panels And Covers Securely In Place</li><li>• Never Defeat, Modify or Bypass Any Safety Interlocks</li><li>• Unauthorized Modifications To This Equipment Will Result In Voiding The Warranty</li></ul>

LD12152

## CHANGEABILITY OF THIS DOCUMENT

In complying with Johnson Controls' policy for continuous product improvement, the information contained in this document is subject to change without notice. While Johnson Controls makes no commitment to update or provide current information automatically to the manual owner, that information, if applicable, can be obtained by contacting the nearest Johnson Controls Service office.

Operating/service personnel maintains the responsibility of the applicability of these documents to the competitive equipment the kit is installed on. If there is any question regarding the applicability of these documents, the technician should verify whether the equipment has been modified and if current literature is available with the owner of the equipment prior to performing any work on the chiller.

---

## ASSOCIATED LITERATURE

MANUAL DESCRIPTION	FORM NUMBER
MV VSD - Safety Instructions	160.00-S1
MV VSD - Installation Checklist	160.00-CL1
MV VSD - Installation	160.00-N8
MV VSD - Operation	160.00-O8
MV VSD - Renewal Parts	160.00-RP8
MV VSD - Wiring	160.00-PW8
MV VSD - Field Connections	160.75-PW3.5

---

### UNIT MODEL NUMBER NOMENCLATURE

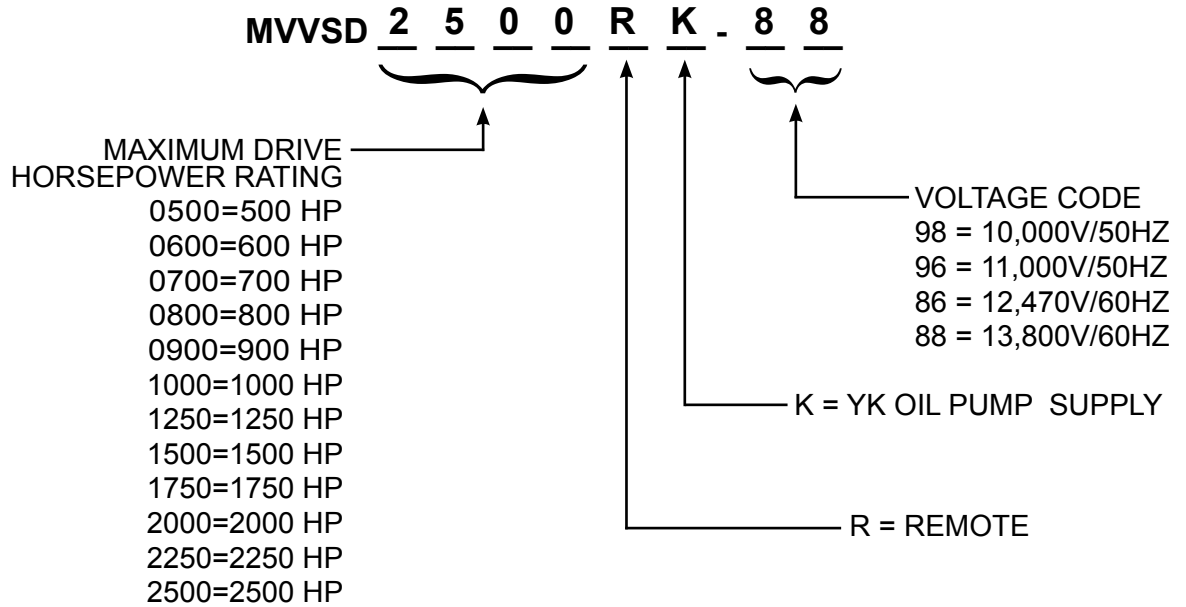

### MV VSD INPUT REQUIREMENTS

<b>Nominal Rated Input Voltage-</b>	10000	11000	12470	13800
<b>Maximum Continuous Input Voltage-</b>	11000	12100	13200	14520
<b>Minimum Continuous Input Voltage-</b>	9000	9900	10790	11880
<b>Maximum Voltage Input Dip-</b>	10%	10%	10%	10%
<b>Starting Min. Input Frequency-</b>	50Hz +/-2Hz	50Hz +/-2Hz	60Hz +/-2Hz	60Hz +/-2Hz
<b>Input Frequency Rate of Change-</b>	10Hz / sec.	10Hz / sec.	10Hz / sec.	10Hz / sec.
<b>Maximum Input Phase Unbalance-</b>	3%	3%	3%	3%
<b>Input Interrupting Capacity-</b>	50KA	50KA	50KA	50KA
<b>Output Voltage-</b>	4160	4160	4160	4160
<b>Maximum Output Frequency-</b>	60Hz	60Hz	60Hz	60Hz

### MV VSD REQUIREMENTS

**Overload** - 105% Full Load RMS current for 40 seconds.

**Anti-recycle Time** - 5 immediate restarts followed by a 10 minute delay.

**Efficiency** - 96% at rated input voltage and load.

**Code Approval** - cUL, UL, and CE.

**Environmental** - 32°F to 104°F (0°C to 40°C), max. 95% humidity, non-condensing, 5000 ft (1524 m) altitude.

**Vibration** - 0.5 G or less @ 10-60Hz

**Enclosure** - NEMA 1, IP20, IEC-529.

**THIS PAGE INTENTIONALLY LEFT BLANK**

## TABLE OF CONTENTS

<b>MEDIUM VOLTAGE VARIABLE SPEED DRIVE OVERVIEW .....</b>	<b>13</b>
<b>SECTION 1 - THEORY OF OPERATION .....</b>	<b>15</b>
General.....	15
<b>SECTION 2 - SYSTEM ARCHITECTURE .....</b>	<b>19</b>
General.....	21
Power Fuses .....	21
Isolation Switch .....	22
Main Vacuum Contactor .....	22
Control Power Transformer .....	23
Pre-Charge Reactor .....	23
Bypass Contactor .....	23
Special Control Power Transformer .....	23
Rectifier Assemblies .....	24
Inverter Section .....	24
Low Voltage Compartment.....	25
<b>SECTION 3 - INSTALLATION .....</b>	<b>31</b>
Inspection .....	31
General .....	31
Safety Precautions .....	31
Handling and Storage.....	31
Location.....	31
Drive Lifting and Assembly.....	32
Mounting Requirements .....	33
Mounting.....	33
Electrical Connection.....	34
Control Wiring.....	34
Power Wiring .....	35
Grounding.....	35
Oil pump Wiring .....	36
<b>SECTION 4 - COMMISSIONING .....</b>	<b>37</b>
Initial Commissioning .....	37
Upstream Protection.....	37
PRE-Energization Check.....	37
Confirmation of Wiring.....	37
Device/Mechanism Check.....	38
Electrical Checks .....	38
Initial Energization .....	38
Start-Up and Test.....	38
<b>SECTION 5 - MV VSD LOCK-OUT / TAG-OUT PROCEDURE .....</b>	<b>39</b>
Lock-out / Tag-out Procedure .....	39
<b>SECTION 6 - MAINTENANCE .....</b>	<b>41</b>
General.....	41
Maintenance Record .....	41
General Inspection .....	41
Daily Inspections .....	42
Regular Inspections.....	42

Main Components .....	42
Cautions on Handling Printed Circuit Boards .....	42
Electrical Joints .....	43
Main Fuses .....	43
Vacuum Contactor .....	43
Vacuum Interrupter .....	43
Bearing .....	44
Closing Coil .....	44
Latch Mechanism .....	44
Auxiliary Switch Contacts .....	44
Operation Checks .....	44
Isolation Switch .....	44
Switch Handle Mechanism and Interlock .....	44
Control Power Transformer .....	44
Power Module Removal / Installation .....	45
Power Module Removal .....	45
Power Module Installation .....	45
Maintenance After a Fault Condition .....	45
Enclosure .....	46
Isolation Switch .....	46
Power Fuse Cartridge .....	46
Terminals and Internal Conductors .....	46
Vacuum Contactor .....	46
Equipment Repair .....	46
Return to Service .....	46
<b>SECTION 7 - TROUBLESHOOTING</b> .....	<b>47</b>
If Power is Removed or Fuses are Blown .....	47
MV VSD Initiated System Shutdown .....	48
MV VSD Fault Messages .....	48
SI Metric Conversion .....	53
Temperature .....	53

## LIST OF FIGURES

<b>FIGURE 1</b> - Medium Voltage Variable Speed Drive – Interior Components.....	13
<b>FIGURE 2</b> - Output Waveforms.....	15
<b>FIGURE 3</b> - OptiView™ Display Screen.....	16
<b>FIGURE 4</b> - Basic Block Diagram.....	17
<b>FIGURE 5</b> - Transformer Assembly.....	19
<b>FIGURE 6</b> - Pre-Charge Reactor.....	19
<b>FIGURE 7</b> - Low Voltage Compartment.....	20
<b>FIGURE 8</b> - Control Display.....	20
<b>FIGURE 9</b> - E-Type Main Fuses.....	21
<b>FIGURE 10</b> - Isolation Switch.....	22
<b>FIGURE 11</b> - Main Vacuum Contactor.....	22
<b>FIGURE 12</b> - Control Power Transformer.....	23
<b>FIGURE 13</b> - Pre-Charge Reactor.....	23
<b>FIGURE 14</b> - Rectifier Assembly.....	24
<b>FIGURE 15</b> - Rectifier Series.....	24
<b>FIGURE 16</b> - Low Voltage Compartment.....	25
<b>FIGURE 17</b> - Phase Detection Module Board.....	26
<b>FIGURE 18</b> - Relays.....	27
<b>FIGURE 19</b> - Gate Signal Driver Board.....	28
<b>FIGURE 20</b> - Gate Signal Driver Board Outline.....	28
<b>FIGURE 21</b> - Logic Board.....	28
<b>FIGURE 22</b> - Logic Board Outline.....	28
<b>FIGURE 23</b> - Modbus Card.....	29
<b>FIGURE 24</b> - I/O Board.....	29
<b>FIGURE 25</b> - MV VSD Display/Keypad.....	29
<b>FIGURE 26</b> - Unit Clearances.....	32
<b>FIGURE 27</b> - Lifting and Assembly.....	33
<b>FIGURE 28</b> - Modbus Connections.....	34
<b>FIGURE 29</b> - Motor Lead Connections.....	35
<b>FIGURE 30</b> - Ground Bus Splice Connection.....	35
<b>FIGURE 31</b> - Oil Pump Connections.....	36
<b>FIGURE 32</b> - Access Panel.....	39
<b>FIGURE 33</b> - Power Module.....	45
<b>FIGURE 34</b> - Control Power Circuit Breaker.....	48

## LIST OF TABLES

<b>TABLE 1</b> - MV VSD Unit Model Reference Chart.....	10
<b>TABLE 2</b> - MV VSD Dimensional Data.....	11
<b>TABLE 3</b> - Over-Current Trip.....	50
<b>TABLE 4</b> - Analog Input Ranges (Low Pressure Chillers).....	53

**TABLE 1 - MV VSD UNIT MODEL REFERENCE CHART**

MVSD MODEL NUMBER	HP	INPUT VOLT-AGE	INPUT Hz	100% OUTPUT FLA Max. at 4160V 60Hz	INPUT CUBICAL WEIGHT (LBS/KG)	CPT CUBICAL WEIGHT (lbs/kg)	TRANSFORMER CUBICAL WEIGHT (lbs/kg)	INVERTER CUBICAL WEIGHT (lbs/kg)
MVSD0500RK-98	500	10000	50	62	2,500 / 1,134	1,400 / 635	7,300 / 3,311	2,500 / 1,134
MVSD0600RK-98	600	10000	50	74			7,500 / 3,401	
MVSD0700RK-98	700	10000	50	87			8,000 / 3,629	
MVSD0800RK-98	800	10000	50	99			8,600 / 3,901	
MVSD0900RK-98	900	10000	50	112			9,000 / 4,082	
MVSD1000RK-98	1000	10000	50	125			9,400 / 4,264	
MVSD1250RK-98	1250	10000	50	155			9,800 / 4,445	
MVSD1500RK-98	1500	10000	50	186			10,200 / 4,627	
MVSD1750RK-98	1750	10000	50	217			10,600 / 4,808	
MVSD2000RK-98	2000	10000	50	248			11,000 / 4,990	
MVSD2250RK-98	2250	10000	50	274			12,300 / 5,580	
MVSD2500RK-98	2500	10000	50	310			13,200 / 5,988	
MVSD0500RK-96	500	11000	50	62	2,500 / 1,134	1,400 / 635	7,300 / 3,311	2,500 / 1,134
MVSD0600RK-96	600	11000	50	74			7,500 / 3,401	
MVSD0700RK-96	700	11000	50	87			8,000 / 3,629	
MVSD0800RK-96	800	11000	50	99			8,600 / 3,901	
MVSD0900RK-96	900	11000	50	112			9,000 / 4,082	
MVSD1000RK-96	1000	11000	50	125			9,400 / 4,264	
MVSD1250RK-96	1250	11000	50	155			9,800 / 4,445	
MVSD1500RK-96	1500	11000	50	186			10,200 / 4,627	
MVSD1750RK-96	1750	11000	50	217			10,600 / 4,808	
MVSD2000RK-96	2000	11000	50	248			11,000 / 4,990	
MVSD2250RK-96	2500	11000	50	274			12,300 / 5,580	
MVSD2500RK-96	2500	11000	50	310			13,200 / 5,988	
MVSD0500RK-86	500	12470	60	62	2,500 / 1,134	1,400 / 635	7,300 / 3,311	2,500 / 1,134
MVSD0600RK-86	600	12470	60	74			7,500 / 3,401	
MVSD0700RK-86	700	12470	60	87			8,000 / 3,629	
MVSD0800RK-86	800	12470	60	99			8,600 / 3,901	
MVSD0900RK-86	900	12470	60	112			9,000 / 4,082	
MVSD1000RK-86	1000	12470	60	125			9,400 / 4,264	
MVSD1250RK-86	1250	12470	60	155			9,800 / 4,445	
MVSD1500RK-86	1500	12470	60	186			10,200 / 4,627	
MVSD1750RK-86	1750	12470	60	217			10,600 / 4,808	
MVSD2000RK-86	2000	12470	60	248			11,000 / 4,990	
MVSD2250RK-86	2250	12470	60	274			12,300 / 5,580	
MVSD2500RK-86	2500	12470	60	310			13,200 / 5,988	
MVSD0500RK-88	500	13800	60	62	2,500 / 1,134	1,400 / 635	7,300 / 3,311	2,500 / 1,134
MVSD0600RK-88	600	13800	60	74			7,500 / 3,401	
MVSD0700RK-88	700	13800	60	87			8,000 / 3,629	
MVSD0800RK-88	800	13800	60	99			8,600 / 3,901	
MVSD0900RK-88	900	13800	60	112			9,000 / 4,082	
MVSD1000RK-88	1000	13800	60	125			9,400 / 4,264	
MVSD1250RK-88	1250	13800	60	155			9,800 / 4,445	
MVSD1500RK-88	1500	13800	60	186			10,200 / 4,627	
MVSD1750RK-88	1750	13800	60	217			10,600 / 4,808	
MVSD2000RK-88	2000	13800	60	248			11,000 / 4,990	
MVSD2250RK-88	2250	13800	60	274			12,300 / 5,580	
MVSD2500RK-88	2500	13800	60	310			13,200 / 5,988	

**TABLE 2 - MV VSD DIMENSIONAL DATA**

<b>MVVSD MODEL NUMBER</b>	<b>SIZE IN (cm) W x D x H</b>	<b>MAX. INPUT CONDUIT</b>	<b>MAX. MOTOR CONDUIT</b>
MVVSD0500RK-98	236 x 44 x 104 (600 x 112 x 264)	(2) 4"	(2) 3" or (1) 4"
MVVSD0600RK-98			
MVVSD0700RK-98			
MVVSD0800RK-98			
MVVSD0900RK-98			
MVVSD1000RK-98			
MVVSD1250RK-98			
MVVSD1500RK-98			
MVVSD1750RK-98			
MVVSD2000RK-98			
MVVSD2250RK-98	278 x 50 x 104 (706 x 127 x 264)	(2) 4"	(2) 4"
MVVSD2500RK-98			
MVVSD0500RK-96	236 x 44 x 104 (600 x 112 x 264)	(2) 4"	(2) 3" or (1) 4"
MVVSD0600RK-96			
MVVSD0700RK-96			
MVVSD0800RK-96			
MVVSD0900RK-96			
MVVSD1000RK-96			
MVVSD1250RK-96			
MVVSD1500RK-96			
MVVSD1750RK-96			
MVVSD2000RK-96			
MVVSD2250RK-96	278 x 50 x 104 (706 x 127 x 264)	(2) 4"	(2) 4"
MVVSD2500RK-96			
MVVSD0500RK-86	236 x 44 x 104 (600 x 112 x 264)	(2) 4"	(2) 3" or (1) 4"
MVVSD0600RK-86			
MVVSD0700RK-86			
MVVSD0800RK-86			
MVVSD0900RK-86			
MVVSD1000RK-86			
MVVSD1250RK-86			
MVVSD1500RK-86			
MVVSD1750RK-86			
MVVSD2000RK-86			
MVVSD2250RK-86	278 x 50 x 104 (706 x 127 x 264)	(2) 4"	(2) 4"
MVVSD2500RK-86			
MVVSD0500RK-88	236 x 44 x 104 (600 x 112 x 264)	(2) 4"	(2) 3" or (1) 4"
MVVSD0600RK-88			
MVVSD0700RK-88			
MVVSD0800RK-88			
MVVSD0900RK-88			
MVVSD1000RK-88			
MVVSD1250RK-88			
MVVSD1500RK-88			
MVVSD1750RK-88			
MVVSD2000RK-88			
MVVSD2250RK-88	278 x 50 x 104 (706 x 127 x 264)	(2) 4"	(2) 4"
MVVSD2500RK-88			

**THIS PAGE INTENTIONALLY LEFT BLANK**

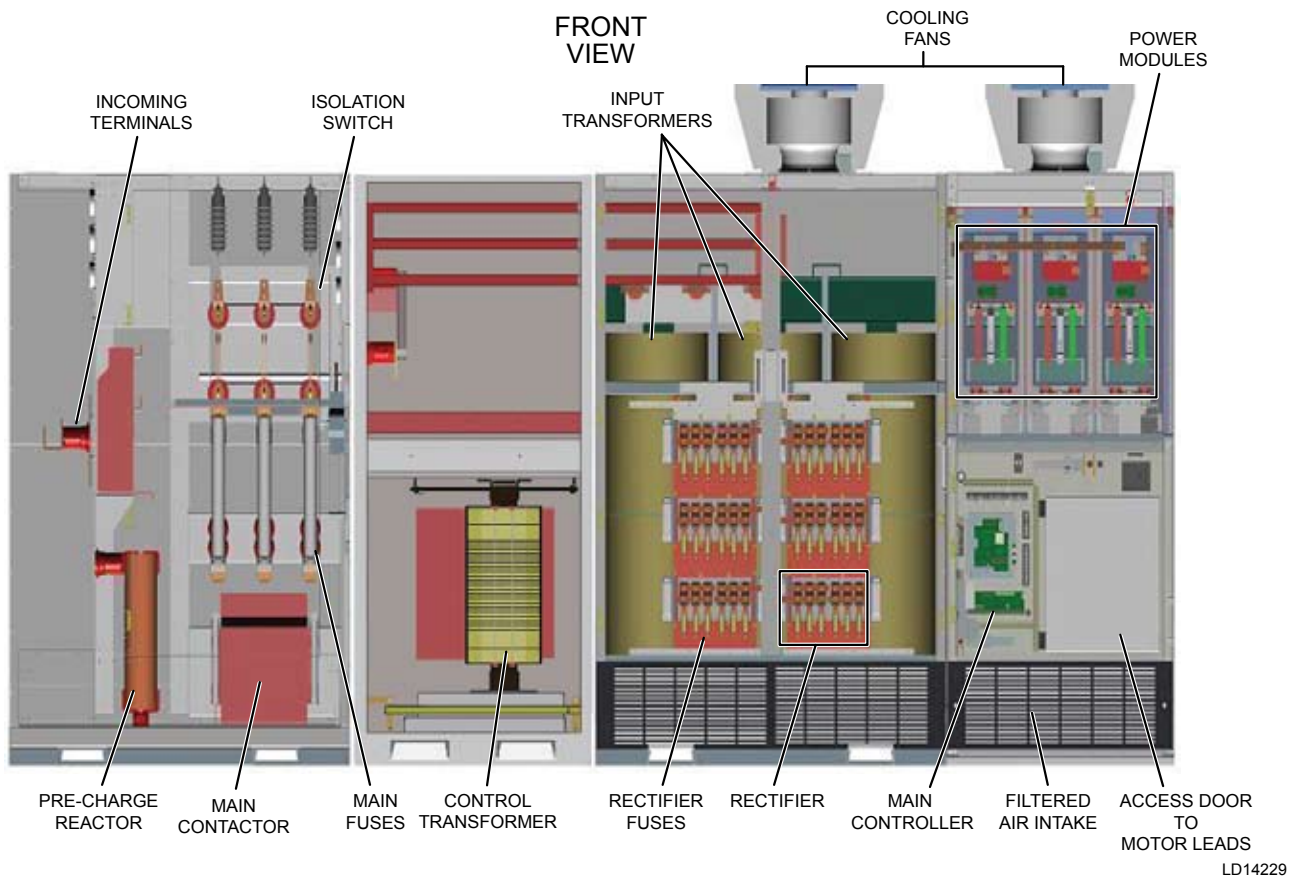

**FIGURE 1 - MEDIUM VOLTAGE VARIABLE SPEED DRIVE – INTERIOR COMPONENTS**

## MEDIUM VOLTAGE VARIABLE SPEED DRIVE OVERVIEW



***Safety is Number One! Voltages present within this drive enclosure may be lethal! Only “qualified” individuals are permitted to service this product!***

This instruction describes the operation, start-up, and troubleshooting of the YORK Medium Voltage Variable Speed Drive (MV VSD). Qualification in this case requires that the individual hold a certificate, proving satisfactory completion of formal training on proper procedures and safety requirements for working on equipment in the medium voltage (600 VAC to 35,000 VAC) class. The qualified individual furthermore is to be knowledgeable of, and adhere to, all safe work practices as required by such documents as: NEC, OSHA, and NFPA 70E. Because available fault current is determined largely due to sizing of the upstream transformers, wiring, and protective devices - available fault current and arc-flash hazard levels must be determined by personnel responsible for the electric

cal systems within the facility where this product is installed. Proper personal protective equipment (PPE) is to be utilized where and when required. This entire publication is to be read thoroughly before servicing this product. Proper lock-out and tag-out procedures are mandatory!



***Under no circumstances should any live testing be performed with the main cabinet doors open, exposing medium voltage components! The energized safe approach distance for this product is to be determined per NFPA 70E. Non-qualified personnel are not to be present within this boundary during energizing, de-energizing, or energized testing (even with cabinet doors closed) on this starter!***

**THIS PAGE INTENTIONALLY LEFT BLANK**

## SECTION 1 - THEORY OF OPERATION

### GENERAL

The YORK Medium Voltage Variable Speed Drive (MV VSD) is an integrated package that works together with the YORK OptiView™ control panel to provide the optimum voltage and frequency to the chiller motor, maintaining energy usage at the lowest possible level for the given chiller conditions. This system is built upon YORK's 10+ years of experience with adaptive capacity control for optimization of chiller motor speed. The control algorithms are the same as employed in YORK's low-voltage variable speed drive products. Customers can be assured this drive product will not just provide a slow ramping up of the chiller motor, but will seek out the lowest operating speed to achieve maximum chiller efficiency.

The MV VSD drive portion of the system is designed to take fixed frequency electrical current and convert this energy to variable voltage and frequency to control the speed of a standard induction motor. We emphasize "standard" induction motor at this point, because there is no need to employ special "inverter-duty" motors in this application. The YORK MV VSD has been designed to eliminate the concerns that often exist with respect to motors applied with variable speed drives.

The output voltage and frequency are maintained in proportion to keep the volts per hertz ratio the same at the motor at all times using a pulse-width-modulation (PWM) type of output. However, the PWM output of this MV VSD is very different from the PWM output of most low-voltage variable speed drives. The output waveform contains similar positive and negative pulses, but these groups of pulses are raised and lowered in amplitude in several steps. As a result, the worst-case instantaneous voltage change seen by the motor is only  $\frac{1}{4}$  the peak voltage. This assures no risk to the motor's insulation system.

Another common concern with induction motors on low-voltage VSDs is the potential for electrical discharge through motor bearings, causing bearing fluting which results in early bearing failure. This situation is eliminated in YORK's MV VSD through use of what is called neutral point clamp technology. What this means is that the output voltage of the MV VSD is developed with respect to a floating neutral and there is no path for currents to pass from the motor back to the source. This eliminates the possibility of any current passing through the motor bearings.

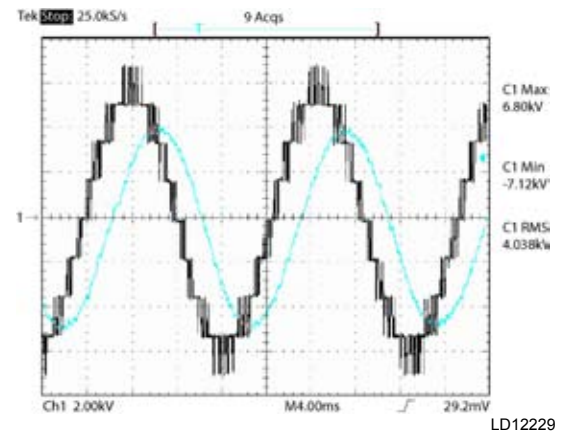

**FIGURE 2 - OUTPUT WAVEFORMS**

In testing conducted by YORK, it has been confirmed that the voltage potential across motor bearings with the MV VSD is even lower than what exists when the same motor is connected to 60 HZ sine wave current. In summary, there is no need for a special motor when applied with YORK's MV VSD.

All YORK MV VSDs contain an input transformer that takes the fixed frequency electrical supply and converts it to many individual secondary supplies. This offers several advantages. The standard offering for primary voltages from 10,000V to 13,800V will be an output of 4160V 60Hz to drive a 4160V motor.

Another advantage of this transformer is that it provides electrical isolation. Also, by shifting the phase angle of the secondary windings and utilizing multiple rectifiers for each phase, most of the harmonics typically associated with variable speed drives are eliminated. VSDs of this type are called "24-pulse" drives. Each input phase has 12 dual-pack diodes, each with its own power fuse. The phase shift between each of the rectifiers causes cancellation of harmonic frequencies. The YORK MV VSD meets the IEEE-519-1992 harmonic distortion guidelines without need for any addition of extra filters or hardware.

The output voltage and frequency to the motor are created by three identical power module assemblies located in the right-hand section of the MV VSD. Each power module is a complete inverter assembly for one phase. These power modules are mounted on tracks with rollers and slides, permitting each pole to be pulled out, away from the cabinet like a large desk drawer. This facilitates checking of components on each pole, and

makes it easier to replace solid-state output devices should a replacement become necessary. Each power module weighs more than 100 pounds, so special lifting hardware is required.

The control logic in the MV VSD governs all operations of hardware within the MV VSD, and passes all pertinent electrical data and system status to the OptiView™ control panel via a communications link. This permits the OptiView™ panel to display information such as the voltage and current in each phase, along with information such as output frequency – similar to the OptiView™ Variable Speed Drive screens that are available on chillers with low voltage VSD systems.

In addition, fault information and histories are available for viewing at the OptiView™ panel. There is no need to open any door on the MV VSD cabinet when the chiller is energized. All control and data display is handled by the OptiView™ control panel.

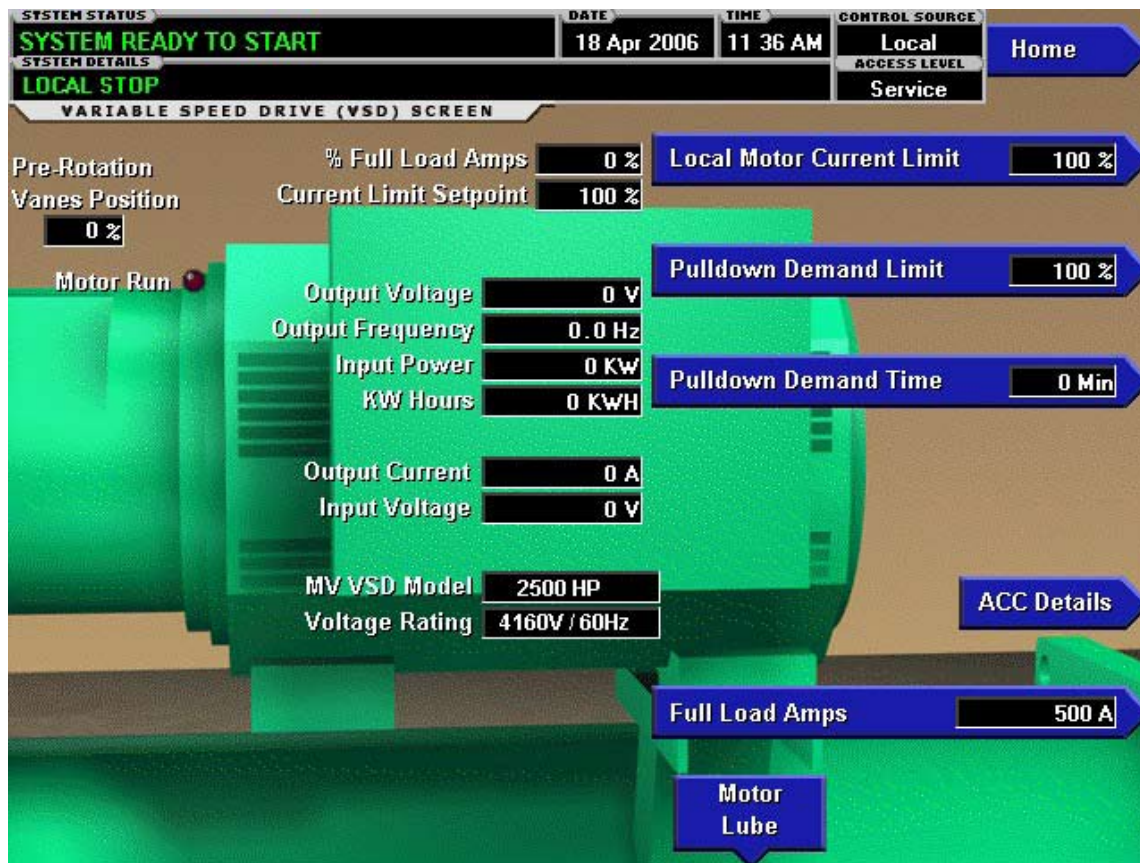

LD12286

FIGURE 3 - OPTIVIEW™ DISPLAY SCREEN

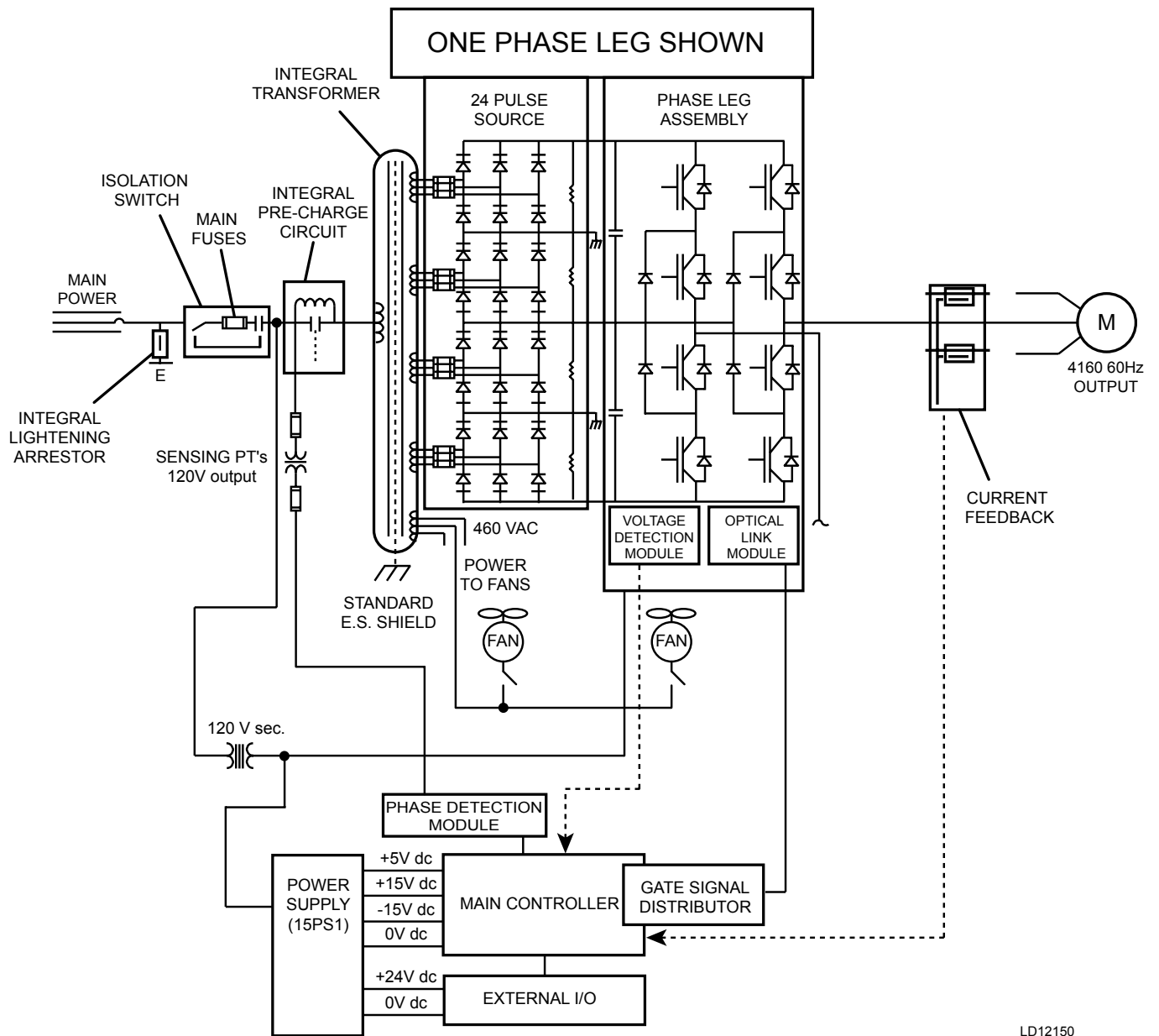
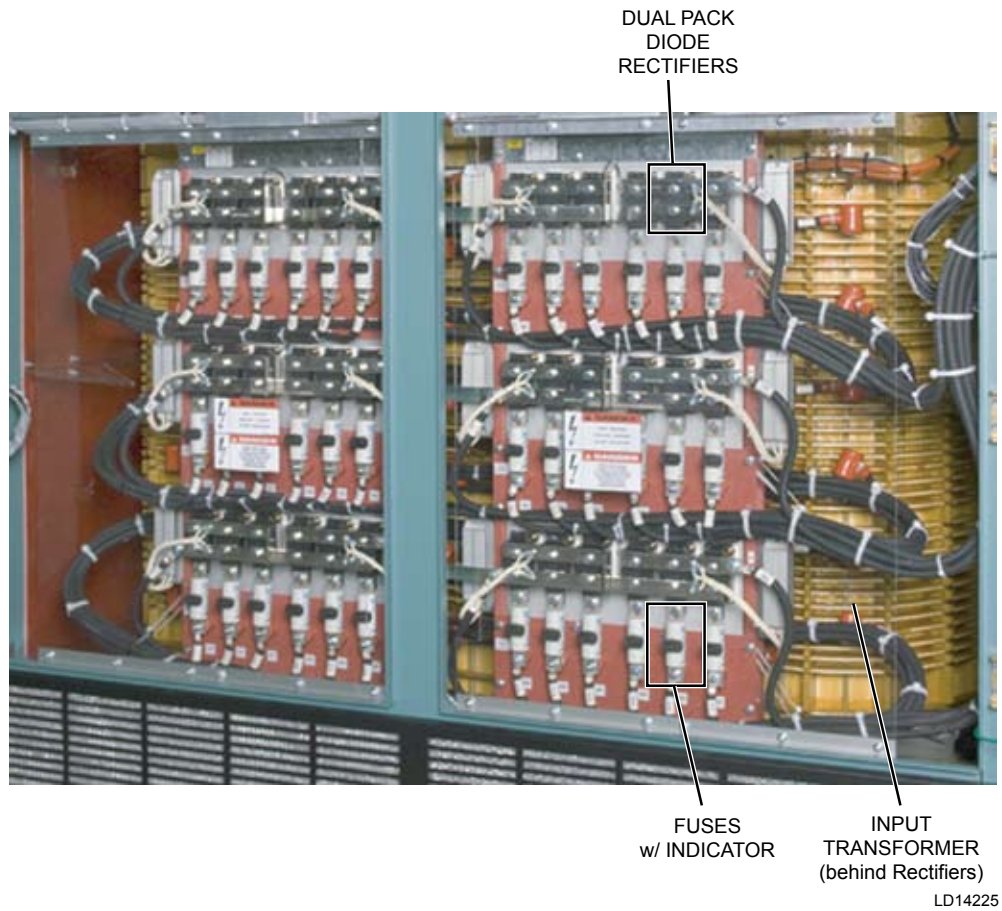

FIGURE 4 - BASIC BLOCK DIAGRAM

**THIS PAGE INTENTIONALLY LEFT BLANK**

## SECTION 2 - SYSTEM ARCHITECTURE



**FIGURE 5 - TRANSFORMER ASSEMBLY**

LD14225



LD14224

**FIGURE 6 - PRE-CHARGE REACTOR**

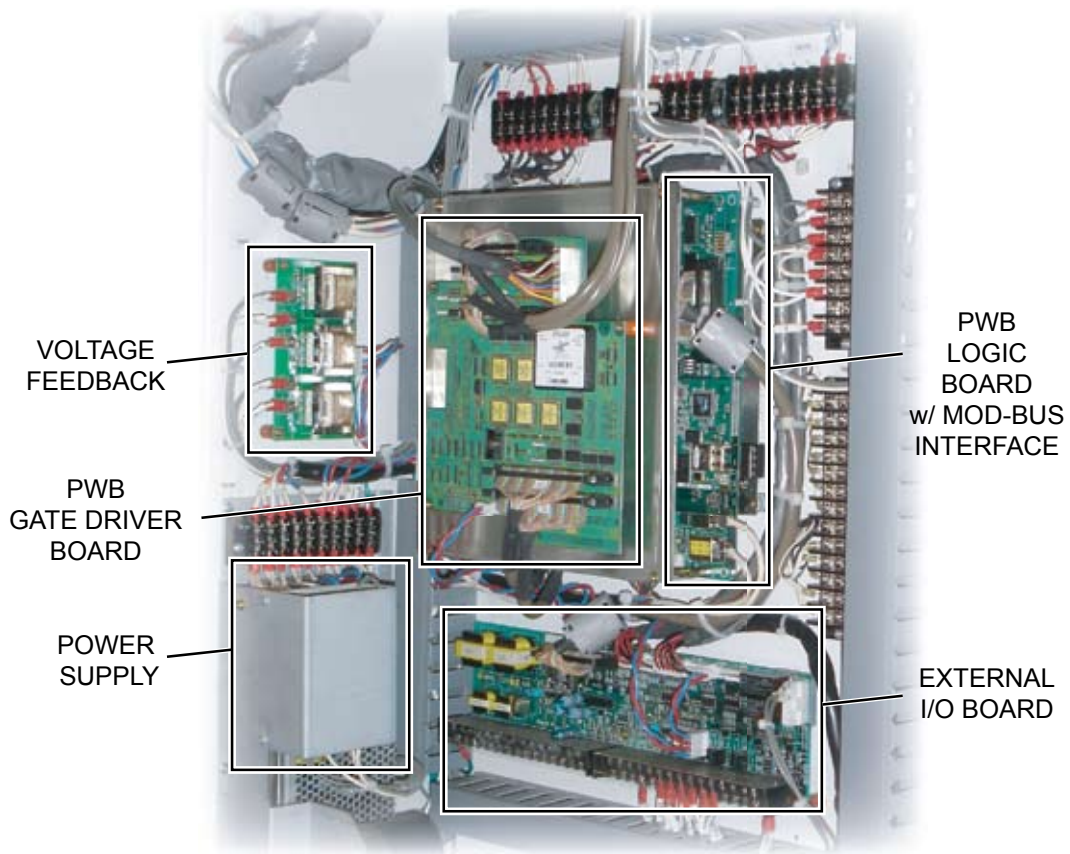

LD12170

**FIGURE 7 - LOW VOLTAGE COMPARTMENT**



LD12172

**FIGURE 8 - CONTROL DISPLAY**

## GENERAL

The YORK MV VSD is a floor-standing, air-cooled, self-contained motor drive for 10,000, 11,000, 12,470 and 13,800 volt 3-phase applications. The cabinet is NEMA 1 rated, and designed for temperatures from 32°F to 104°F (0°C to 40°C), with relative humidity of 20% to 95%, non-condensing. If the MV VSD is to be applied at greater than 5000' (1524m) it will need to be reviewed as a special quote. It is designed to interface to the YORK OptiView™ control panel. All setup parameters are entered through the OptiView™ panel, and all data and fault information from the drive are communicated back to the OptiView™ panel for display and access through history screens.

All components of the Medium Voltage Variable Speed Drive are contained within standard 236", or 278" wide enclosures.

Incoming power connections are made inside the top section of the enclosure to a three-phase load-break rated isolation switch. Main power supply wiring may enter at the top of the cabinet, adjacent to this switch – or may be brought into the cabinet from the floor. Conduit entrance plates are provided at the top and the bottom of the cabinet. There is also a wire path provided along the left cabinet wall for optional bottom-entry wiring. Tie-straps are provided to secure the wires if this option is chosen.

The main incoming power isolation switch is rated to open under load, although the number of operations under load is very limited.



***Do NOT open this switch as a normal means of shutting down the system.***

When the switch is open, all three contact blades should be resting against a metal bracket which assures the load-side circuits are de-energized and discharged. Visual confirmation of an open switch can be made through the viewing window in the cabinet door.



***Before opening the cabinet of the MV VSD, standard lock-out/tag-out procedures must be followed, and visual confirmation of an open incoming power switch must be made through the viewing window!***



***Additionally, it is necessary to wait a minimum of 15 minutes before opening the cabinet door to allow internal capacitors sufficient time to discharge.***

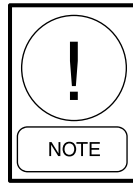

***The LEDs on the power module indicate voltages present on the DC bus and DC bus voltage can also be monitored on the keypad with the input isolation switch closed and the main contactor open.***

## POWER FUSES

From the load side of the incoming power isolation switch, power is routed to either three or six (depending on MV VSD size) E-type medium-voltage motor-starting power fuses inside the drive.

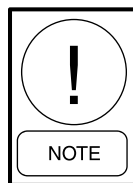

***Upstream customer fuses should be sized such that the starter's internal fuses should open first. Most often upstream fuses will be E-type fuses which have a different time/current characteristic compared to R-type fuses.***

The time/current characteristics of any fuses upstream of the drive must be selected to handle the inrush permitted by the E-type fuses in the drive input section. The load side of the MV VSD fuses supplies power to the main power transformer (T1), the 3-phase oil pump and control power transformer, the MV VSD potential transformer (10PT1 and 10PT2), and to the in-line and bypass contactors.



LD14226

**FIGURE 9 - E-TYPE MAIN FUSES**

## ISOLATION SWITCH

Power is switched ON and OFF to the MV VSD by a fixed-mounted, externally operated, three-pole isolation switch. When the switch is in the OFF position, incoming power is isolated from the transformer compartment in the HV input section.



*Live power is isolated behind a plexiglass shield when the input switch is in the open position.*

Three bolted-in current-limiting power fuses provide primary short-circuit protection for the MV VSD and load circuit.

These fuses are connected between the isolation switch and the vacuum contactor. When the switch is closed by operating the external handle, incoming power is applied to the line side of the power fuses. In this position, the motor or other load may be switched on and off by operating the vacuum contactor.

The Isolation Switch is mechanically interlocked with the compartment door. Thus, it is possible to have visual evidence through the viewing window that the power source is isolated before entering the medium voltage compartments. The switch is also provided with lock-out provisions.

Input Isolation Switch in the HV input section is load breaking although intended load-breaking operation is performed with main input contactor, except for emergency situations.



LD14227

**FIGURE 10 - ISOLATION SWITCH**



*Do NOT connect additional load to the isolation switch.*

## MAIN VACUUM CONTACTOR

The Vacuum Contactor used in these controllers is a compact, fixed mounted device. It is mounted on the floor of the components compartment of the HV input section directly behind the access door, below the isolation switch.

Switching occurs entirely within vacuum bottles which results in long life with virtually no maintenance. Input isolation switch is load-breaking and contactor will open if input switch is opened. The main input vacuum contactor also provides drive protection opening when a major fault is detected.



LD14230

**FIGURE 11 - MAIN VACUUM CONTACTOR**

When the Main Contactor closes, three-phase power is applied to the transformer primary through an air-core pre-charge reactor. This device limits the inrush of current into the transformer and bus capacitors to minimize stress of these devices when power is applied. The pre-charge reactor is in the circuit for only  $\frac{1}{2}$  a second and once the transformer and bus capacitors are energized, a second vacuum contactor closes to short out the pre-charge reactor and provides full current to the drive. The pre-charge reactor and shorting contactor are also referred to as the "Soft-charge Circuit" and is located on the left wall in the components compartment of HV input section.

## CONTROL POWER TRANSFORMER

A pair of Control Power Transformers are fixed mounted on the rear wall of the HV input section components compartment beneath the main input fuses and behind the main input contactor. Power is supplied through the fuses on the primary of the control power transformers from the load side of the main power fuses.

These transformers are used to supply power to the low voltage circuits of the MV VSD. This includes the power for the vacuum contactor operating coil and for various instrumentation.

An electrical interlock is provided to ensure that all load is disconnected from the control power transformer secondary winding before the power isolation switch can be opened or closed.



LD12184

**FIGURE 12 - CONTROL POWER TRANSFORMER**

## PRE-CHARGE REACTOR

When the main vacuum contactor closes, 3-phase power is applied to the transformer primary through one 3-phase Pre-charge Reactors which are large air-core reactors located adjacent to the main contactor. This device limits the inrush of current into the transformer primary to prevent an electrical surge. The Pre-charge Reactor is in the circuit for only  $\frac{1}{2}$  a second. Once the transformer is energized, a second vacuum contactor closes to bypass this reactor, permitting full voltage and current to be applied to the transformer primary.

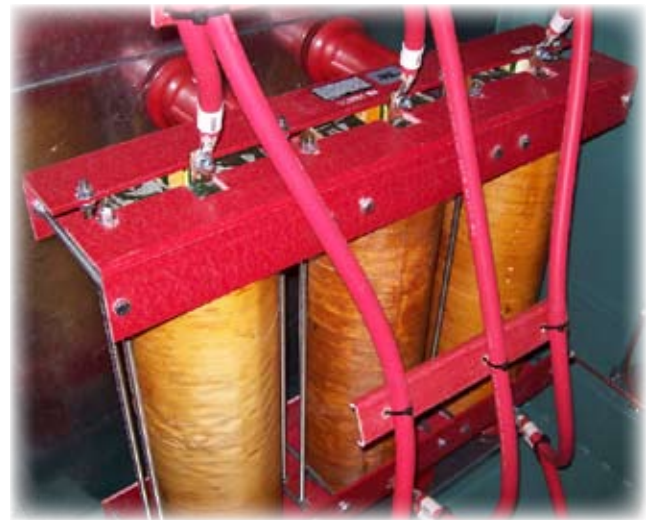

LD12237

**FIGURE 13 - PRE-CHARGE REACTOR**

## BYPASS CONTACTOR

There is a second vacuum contactor assembly that appears identical to the main vacuum contactor and is located above the pre-charge contactor on the left hand wall of the HV input section components compartment. Once voltage is detected on the output of the transformer, this contactor closes to bypass inductors that are in series with the transformer primary.

## SPECIAL CONTROL POWER TRANSFORMER

There is a special medium voltage step-down transformer located in a separate cubicle between the HV input and main transformer section. This transformer serves to supply 120 VAC control power to the YORK OptiView™ control panel, and three-phase 460 VAC power to the chiller oil pump. With this combination of secondary windings, you might note that there are five output connections which is a bit unusual for a transformer (three for 460/3, and two more for 120/1).

## RECTIFIER ASSEMBLIES

The Rectifier Assemblies are located immediately inside the doors to the transformer cabinet, behind clear plastic panels. There are a total of 12 three-phase rectifier groups, oriented four across and three down. The arrangement is such that the top row feeds the T1 inverter section, the middle row feeds T2, and the bottom row feeds T3. Looking at just one row, from left to right, we see that there are four identical three-phase rectifiers, wired in series. Each 3-phase group contains six diodes (2 per dual pack), with a total of 24 diodes in each output phase T1, T2, and T3.

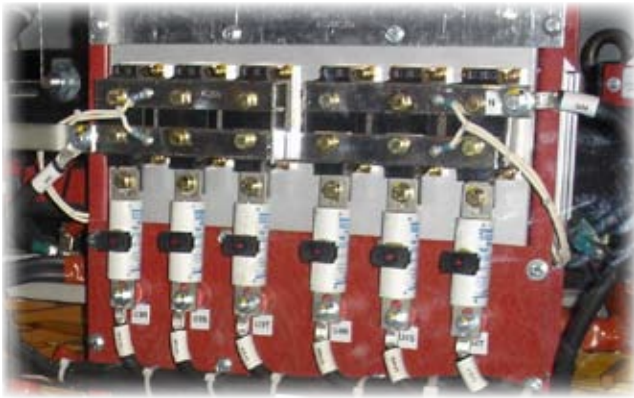

LD12228

**FIGURE 14 - RECTIFIER ASSEMBLY**

The following voltages are discussed with respect to a 4160 volts MV VSD. For 2300, and 3300 volts units, the values will appropriately lower.

The DC voltage output from each three-phase group of devices is 900 volts DC. If you are familiar with low-voltage VSDs, the DC link in most low-voltage drives has capacitors in series from the negative bus to a center point, and from the center point to the positive bus. In a similar manner, each phase of the rectifier section of the MV VSD has two 900 volt rectifiers in series to produce 1800 volts from the negative bus to the center point, and two more 900 volt rectifiers in series to produce 1800 volts from the center point to the positive bus. Therefore the total bus voltage is 3600 volts from the left side to the right side of each row of four devices.

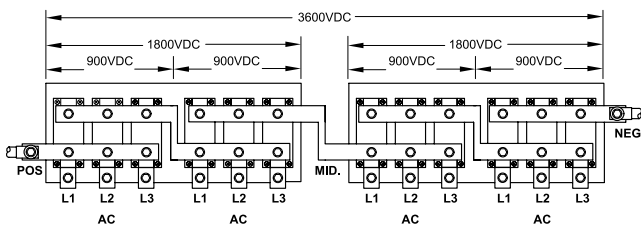

LD12227

**FIGURE 15 - RECTIFIER SERIES**

There are actually three separate, isolated 3600 volt DC supplies from top to bottom, feeding the three output phases, T1, T2, and T3. It is important to note that these supplies are isolated because 3600 volts DC is not enough to produce 4160 volts AC at the output of the drive. Isolated supplies permit the drive to not only switch the motor output between positive and negative as is done in low voltage drives, but also permits the drive to switch between positive and negative buses and isolated, floating neutral. This enables the phase to phase voltage to achieve 4160 volts, given three individual DC links of 3600 volts.

Note that each of the 12 rectifier sections is supplied by three AC phase connections labeled L1, L2, and L3. Each of these rectifiers is supplied from a dedicated three-phase secondary coming from the large transformer inside the drive. Each rectifier module contains two diodes, so each three-module section contains 6 solid-state rectifier devices. This arrangement is common in low-voltage drives, and is often referred to as a 6-pulse rectifier, or 6-pulse front end. Because there are four groups of rectifiers for each phase, it really has 6X4, or a 24-pulse front end.

In each phase, the four sets of windings are wound on the transformer in such a way that there is a slight phase-shift between each set of windings. This causes the current conducted by each 6-pulse rectifier to occur at a time slightly different from the other three 6-pulse rectifiers in the same phase. Current is conducted in 24 pulses instead of only 6 pulses. This makes the current conduction much more smooth and the harmonics produced are far lower. This 24 pulse drive is able to meet IEEE-519 guidelines without addition of any line reactors or filters.

## INVERTER SECTION

The inverter section is comprised of three output power modules - one for each phase. Each output power module includes the bus capacitors for its own DC link, a set of IGBT output transistors to switch voltage to the motor, and a set of output transistors to switch voltage between the power module and the floating neutral point, or bus. This floating neutral is physically a horizontal plated-copper bus bar that ties all three output power modules together. Other than this connection, each power module has connections for three cables coming from the rectifier section for that phase, and one cable that connects the power module to the output terminals that tie to the motor.

The three wires coming over from the rectifier section represent positive bus (P), negative bus (N), and mid bus, or common (C) for that phase. Having three separate wires for each phase, there is a total of nine wires that must pass from the rectifier section to the three poles of the inverter output section. These wires are routed through a very narrow opening between the rectifier and inverter output cabinets.

The wire that connects from the output pole to the motor is labeled (ACL). The wire that connects to the pole at this location is routed through the cabinet to the motor output terminals that are located behind a hinged access panel inside the low-voltage section of the MV VSD cabinet.

Note that each power module is mounted on red glastic insulators. The structure of each module itself is tied to the mid-bus connection to that module. The glastic standoffs on each power module isolates low voltage control circuit voltages from main power voltages preventing dangerous voltages from being present in the controls section of the drive. circuits are electrically isolated by means of fiber optic cables transmitting firing pulse commands to the power devices on the power module.

Each Power Module is also mounted on a set of slides and rollers that allows the module to be drawn out from the cabinet like a desk-drawer. These module are very heavy and lifting hardware is necessary to lower the module to the floor.

**LOW VOLTAGE COMPARTMENT**

The location and size of the low voltage compartment will vary depending on the particular MV VSD arrangement. The low voltage compartment contains components rated 600 volts maximum. These include such items as overload relays, pilot devices, control relays, etc.



***Hazardous voltage. Turn OFF and lock-out/tag-out circuit power before servicing.***

A subpanel is located behind the low voltage door. This subpanel is hinged in such a way it can be swung open if necessary to gain access to the motor output terminals which are located directly inside.

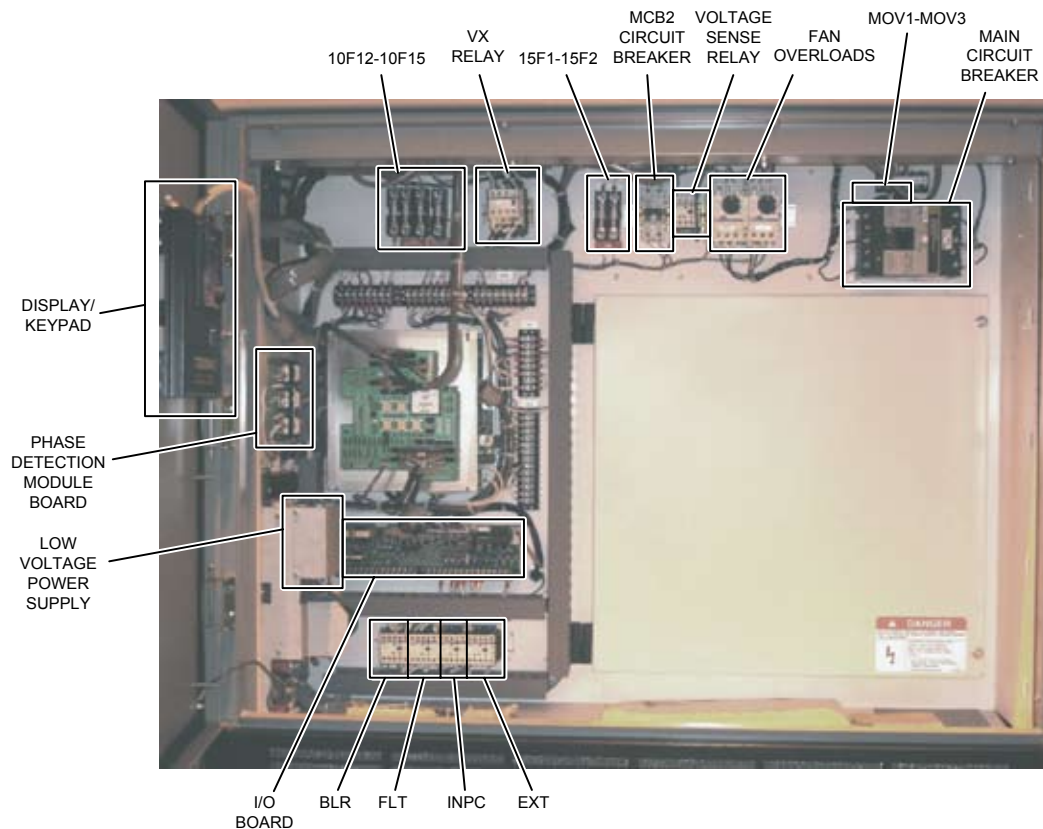

LD12185

**FIGURE 16 - LOW VOLTAGE COMPARTMENT**



***Do NOT open this subpanel at any time unless the MV VSD has had power removed and locked out! Additionally, 15 minutes must elapse after powering down to allow time for the internal capacitors to discharge prior to opening this panel!***

Low voltage vertical wiring routes into the upper and lower left hand corners of the low voltage compartment. A horizontal low voltage wireway is provided at the lower front of each low voltage compartment. At each end of the wireway there is an opening for inter-cubicle control wiring.

Because the low voltage compartment contains 3-phase 460 volt circuits in addition to 120 volt control power, it is important to take all safety precautions as would normally apply when working on energized 3-phase 460 volt equipment.



***Proper protective gear must be worn in accordance with NFPA 70E and OSHA requirements. Failure to adhere to the required safe work practices could result in serious injury or death.***

There are two separate sources of 3-phase 460 volt power that can be present inside the low voltage compartment:

The first is the 3-phase supply that comes from what is called a tertiary winding on the large input transformer. This extra 3-phase winding is connected to the line side of a 3-phase circuit breaker located in the upper right area of the compartment. This circuit breaker also can serve as a disconnect for this power source. The load side of this 3-phase breaker supplies power to each of the cabinet cooling fans on top of the enclosure. Each fan is protected by its own motor overload relay which is located adjacent to the circuit breaker.

A second 3-phase supply comes from the special transformer located in the auxiliary transformer section between the HV input and main transformer section. This transformer has an extra single phase 120 volt secondary in addition to its 3-phase 460 volt secondary. Both secondary windings are protected by fuses located in the low voltage compartment. Terminals are provided on the bottom area of the compartment for connection of wiring that is routed over to the OptiView™ panel and to the oil pump on the chiller.

There are also two additional sources of 120 volts from two control power transformers (10PT1 and 10PT2) located adjacent to the isolation switch and main contactor. Power from these two transformers is applied to the large DC power supply and to the “PDM” (phase detection module) board located within the low voltage compartment. There are only two transformer windings creating this supply, it is possible to detect all three phase since the third phase is the vector difference between the other two phases.

**Phase Detection Module (PDM drawing designation) Board** - This board is located along the left side wall of the low voltage compartment. On this board are three transformers that take 120 VAC and step it down to 12 VAC. Two of these transformers are wired to the two control power transformers mentioned above (10PT1 and 10PT2). The output from these two transformers is used by the logic at connector CN19 to measure the voltage of all three phases, with the third phase being calculated by the logic. The third transformer on the PDM board supplies a 12 VAC “control power healthy” signal to the Gate Signal Driver (GSD) at connector CN5 on the GSD. Note that each of these small transformers has an on-board fuse wired in series with its primary.



LD12240

**FIGURE 17 - PHASE DETECTION MODULE BOARD**

**Low Voltage Power Supply** - The low voltage power supply is a commercially manufactured supply that takes 120 VAC and provides supplies of +5, +15, -15, and +24 volts DC to power the logic circuits in the MV VSD. The common sides of each supply voltage are tied together internally, within the power supply.

Across the Top of the Low Voltage Section are several fuses, relays, circuit breakers, and overloads. Refer to *FIGURE 16* from left to right across the top are:

**Fuses 10F12 through 10F15** – These are fuses for the special transformer that supplies the chiller oil pump and OptiView™ control panel. The first three fuses (10F12, 10F13, and 10F14) are for the 3-phase 460 VAC/60Hz or 400VAC/50Hz oil pump supply. The fourth fuse (10F15) is on the hot side of the 120 VAC supply to the OptiView™ panel.

**VX Relay** – This relay is an unusual device having three contact sections stacked on top of each other. The purpose of this relay is to assure all control transformer loads are disconnected from incoming power prior to operating the isolation switch. The bottom section of this relay opens two of the phases of supply to the oil pump. The middle section opens the third phase of the oil pump supply and one of the circuits from the two 35:1 control transformers (10PT1 and 10PT2) that supply the MV VSD. The top contact section opens the remaining 35:1 transformer supply and the hot side of the 120 VAC supply to the OptiView™ panel.

**Fuses 15F1 and 15F2** – These fuses are on the 120 VAC secondary windings of the two 35:1 control power transformers (10PT1 and 10PT2) that supply the MV VSD.

**MCB2 Circuit Breaker** – This two-circuit breaker is in series with fuses 15F1 and 15F2, addressed above. It functions as a convenient MV VSD control power on/off switch.

**Voltage Sense Relay** – This relay is powered by 460 VAC across L1 and L3 of the 3-phase power to the MV VSD fans. It is connected to the load side of the fan circuit breaker, and its normally closed contacts are in series with the fan overloads and over-temperature detectors.

**Fan Overloads** – There is a separate fan overload for each fan on top of the MV VSD. The normally closed contacts of each overload relay are wired in series. Each overload must be field adjusted to the FLA for its individual fan.

**MCB1 Circuit Breaker** – This three-phase 460 VAC breaker is on the secondary of the 3-phase main-transformer tertiary windings that feed the fans on top of the MV VSD.

**MOV1 through MOV3** – These are 460 VAC rated metal oxide varistors that are on the load side of the MCB1 breaker. They serve to protect the devices on the load side of the breaker against voltage transients.

Across the Bottom of the Low Voltage Section are four relays:

**BLR** – This relay is referred to as the “hard-fault relay”. It is controlled by the logic to shut down the MV VSD in the event there is a fault condition detected. Its 24 VDC coil is supplied a constant 24 volts from P24, and the opposite side of this relay coil is pulled to ground by I/O digital output #5, in order to engage the relay.

**FLT** – This relay provides a set of dry contacts that are wired back to the OptiView™ panel to advise the panel of a motor controller shutdown (53 to 16 circuit in the panel). This relay is supplied a constant 24 volts from P24, and the opposite side of this relay coil is pulled to ground by I/O digital output #3, in order to engage the relay.

**INPC** – This relay controls the main input vacuum contactor device. Its contacts are in series with a set of BLR contacts to the coil of the main vacuum contactor. This relay is supplied a constant 24 volts from P24, and the opposite side of this relay coil is pulled to ground by I/O digital output #4, in order to engage the relay. Note that the MV VSD does not have a similar relay for controlling the pre-charge vacuum contactor. This vacuum contactor is controlled by a small relay (RY2) located on the I/O board and wired to connector CN3.

**EXT** – This is the start signal interposing relay to interface the OptiView™ panel start signal to the MV VSD. It has a 120 VAC coil that is wired back to the OptiView™ panel on terminals #2 and #24. The dry contacts of this relay are connected to digital input #1 on the I/O board. One side of the dry contacts is wired to logic common to pull the digital input low in order to start the MV VSD. Note that in addition to this start signal, the MV VSD also requires a software commanded run signal that is sent over the mod-bus serial communications cable. Both run commands must be initiated within 5 seconds of each other or a run relay fault will be generated.



LD12239

**FIGURE 18 - RELAYS**

**Gate Signal Driver Board (GSD drawing designation)** – This board is fully visible, mounted to a metal plate that holds it in place above the Logic Board and Mod-Bus Communications Board. This board takes the transistor firing signals from the logic board and provides isolated and buffered signals that are passed along to the gate drivers in each output pole assembly. The logic signals are applied at connectors CN1 and CN2 on this board. A “control power healthy” signal is applied at connector CN5, and DC operating voltages are supplied at connector CN4. The outputs to the three pole assemblies are provided at connectors CN3U, CN3V, and CN3W. Designators U, V, and W relate to output phases T1, T2, and T3 - in that order.



LD12186

**FIGURE 19 - GATE SIGNAL DRIVER BOARD**

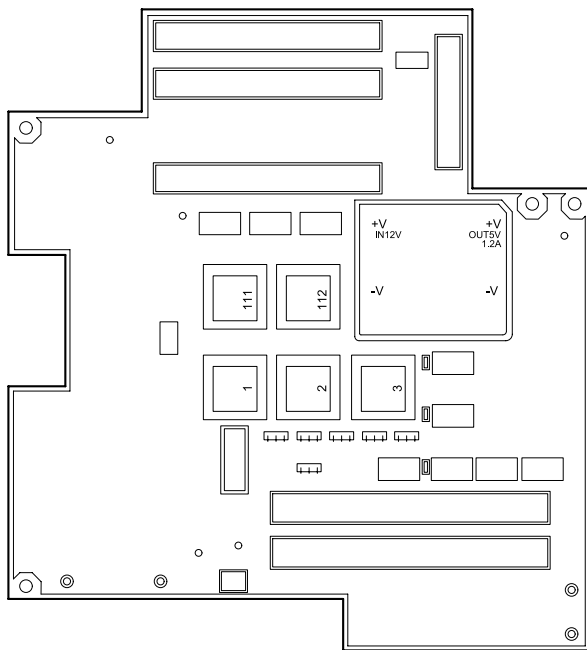

LD12175

**FIGURE 20 - GATE SIGNAL DRIVER BOARD OUTLINE**

**Logic Board (CTR drawing designation)** - The logic board is mounted to the back-wall of the low voltage section and is obscured by the Mod-Bus Communications board that is mounted piggy-back to the logic board, and by the Gate Driver Board that sits above the logic board on its own metal plate. The logic is the heart of the MV VSD. Non-volatile memory holds the program which is loaded into RAM memory upon power up of the MV VSD.

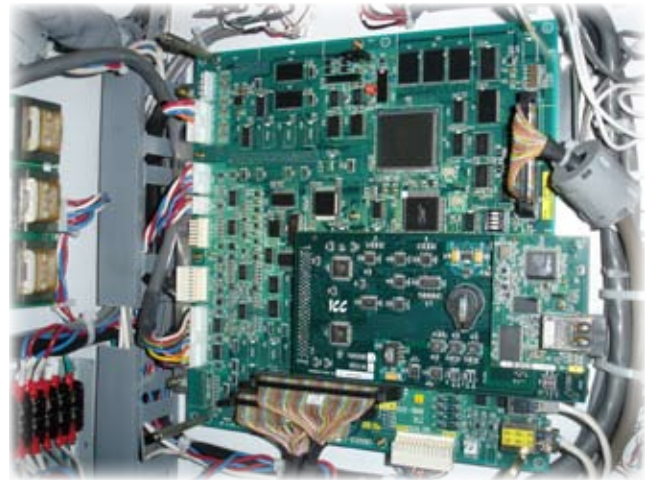

LD12285

**FIGURE 21 - LOGIC BOARD**

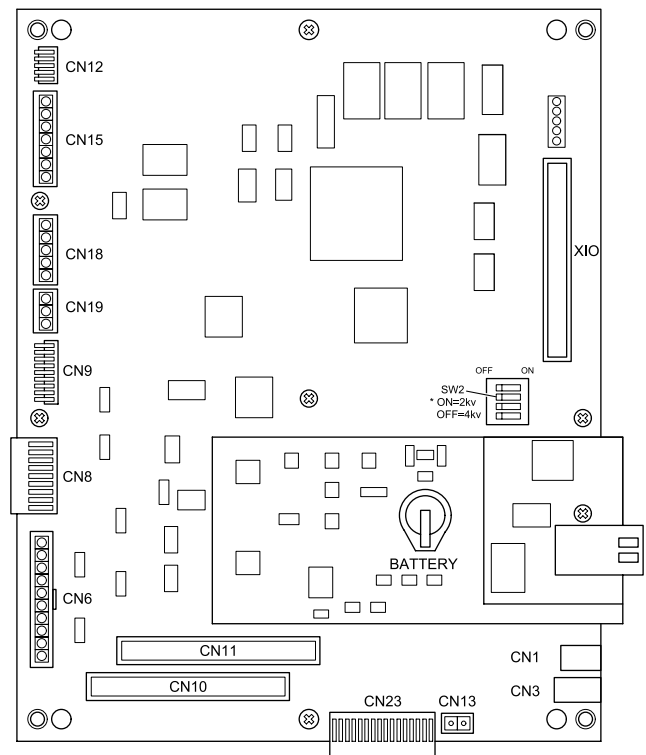

LD12284

**FIGURE 22 - LOGIC BOARD OUTLINE**

**Mod-Bus Communications Board (Modbus Card)** – This board is mounted in a piggy-back fashion to the logic board. Its purpose is to translate communications in mod-bus format to protocol that is recognized by the MV VSD logic. Communications wires from the OptiView™ panel connect to a terminal block within the low-voltage section and in turn are connected to the TB1 connector on this board. The screw terminal portion of this connector separates from the board by pulling the connector body to the right. Once wire connections are made, the connector body can be plugged back into the board. These four connections from top to bottom are A, B, signal ground (SG), and Shield. There is a two-position dip switch along the bottom edge of this board. Both switches should always be in the down, or off, position. Also note that there is a lithium “button” type battery cell on this board. The life-time of this battery is in excess of 5 years, and much longer in cases where control power is never removed for long periods of time.



LD12285

**FIGURE 23 - MODBUS CARD**

**I/O Board (XIO drawing designation)** – The I/O board is used to interface logic board inputs and outputs to the world of the MV VSD. Inputs to this board are 24 VDC logic level. There is one output that is controlled by a relay that resides on the I/O board itself – this is the precharge vacuum contactor signal at

connector CN3 from relay RY2 on this board. All other outputs are controlled through external relays (e.g. BLR, FLT, INPC) that are operated by 24 VDC logic outputs from this board.



LD12238

**FIGURE 24 - I/O BOARD**

**Display/Keypad (DISP/IPAD drawing designations)** – The display/keypad is mounted on the back of the door to the low voltage section. The main purpose of this device is to provide time stamp references for events logged within the MV VSD logic.

Additionally it provides an Ethernet connector to which a laptop PC can be connected for factory testing purposes. All other functions of the display/keypad are duplicated through the OptiView™ panel. Buttons on the keypad permit local control of MV VSD speed, however normally this keypad should be left in the remote mode to permit control to be governed by the OptiView™ panel. System status and fault information can be viewed on the device’s display screen, however this same information is communicated to the OptiView™ panel for display on the OptiView™ screen.



LD12187

**FIGURE 25 - MV VSD DISPLAY/KEYPAD**

This device operates on 24 VDC that is derived from the XIO board. Display data is sent from the logic board connector CN1 via a shielded cable. Control signals are passed to/from the logic board via a similar shielded cable plugged into CN3 of the logic board.



*Although these connectors look very much like standard Ethernet connections, DO NOT attempt to connect any type of PC hardware to these connectors. There are control signals present in these cables that are NOT compatible with Ethernet communications that could destroy the PC.*

The display/keypad has several characteristics defined as:

**Graphical LCD** - Displays user information in text and numerical form.

**Local/Remote LED** - This green LED is illuminated when in local mode, and extinguished while in remote mode. The display/keypad should be left in the remote mode for normal MV VSD operation.

**Status LED :**

- NOT illuminated - NOT ready and
- NOT running
- Green LED only - Ready and NOT running
- Red LED only - Ready and running
- Fast blinking Red LED - Fault
- Slow Red LED if running, slow Green if NOT running - Alarm
- Alternating Red and Green LED when ready or running

**Local/Remote Key** - Toggles between local and remote mode while the drive is not running. Press and hold the key for 2 seconds to toggle between modes.

**MON/PRG Key** - This key will cycle through the tabs.

**RUN Key** - Initiates a start command when the VSD is in local mode, and the display screen is in the main tab.

**ENTER Key** - Selects a menu item to be changed or accepts and writes the changed data of a selected field.

**ESCAPE Key** - This multi-function Escape key allows the user to cancel changes made to a programming field if pressed, while the field is selected (highlighted), returns the user to the previous level of the menu tree, and cycles through the display tabs.

**STOP Key** - This initiates a stop request when operating in local mode, and is functional in all screens. When double-pressed within 1.5 seconds, it initiates a (gate block) coast to stop. This function always works. The drive must reset after a double-press stop.

**UP Key** - Scrolls up a menu listing and increments a selected field's parameter data.

**DOWN Key** - Scrolls down a menu listing and decrements a selected field's parameter data.

**Encoder** - This multi-functional device scrolls up and down a menu listing, increments/decrements the data in a selected programming parameter field, and functions as the enter key when pressed.

**Commissioning Tool Port** - Ethernet port is used for communication to the commissioning and support tool.

**RESET Pushbutton** - This push button is used to clear inverter faults and alarms displayed on the LCD.

**INTERLOCK Pushbutton** - This pushbutton is used to disable the inverter via a hard-wired circuit. The pushbutton is illuminated while the inverter is interlocked, and extinguished for normal operation. Operating the INTERLOCK pushbutton will result in an inverter gate driver block and free-run deceleration of the load.

## SECTION 3 - INSTALLATION

### INSPECTION

Remove any transit packing and inspect the unit to ensure that all components have been delivered and that no damage has occurred during transit. If any damage is evident, it should be noted on the carrier's freight bill and a claim entered. Any major damage must be reported to your local YORK/Johnson Controls representative.

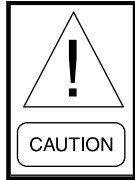

***Do NOT install or energize equipment that has been damaged. Damaged equipment may fail during operation resulting in further equipment damage or personal injury.***

### GENERAL

Before installing the drive, ensure:

- The drive is the correct voltage and current rating for the motor being started.
- All of the installation safety precautions are followed.
- The correct power source is available.
- The installation site meets all environmental specifications for NEMA 1.
- The chiller being started is in proper working condition and ready to be started.
- Any power factor correction capacitors (PFCCs) if installed, are located on the power source side of the drive and not on the motor side.
- Ensure that the drive will be positioned so that the cabinet door(s) has ample clearance, and all of the controls are accessible.



***Failure to remove power factor correction or surge capacitors from the load side of the drive will result in serious damage to the equipment which will not be covered by the equipment's warranty. The capacitors must be powered from the line side of the drive. An auxiliary contact can be used to energize the capacitors after the motor has reached full speed.***

### SAFETY PRECAUTIONS

To ensure the safety of the individuals installing the drive, and the safe operation of the drive, observe the following guidelines:

- Ensure that the installation site meets all of the required environmental conditions (see page 6).
- **LOCK-OUT/TAG-OUT ALL SOURCES OF POWER!**
- Follow all NEC (National Electrical Code) and/or C.S.A. (Canadian Standards Association) standards.
- Remove any foreign objects from the interior of the enclosure.
- Ensure that wiring is installed properly by an qualified electrician.
- Ensure that the individuals installing the drive have proper personal protective equipment (PPE).

### HANDLING AND STORAGE

- Use proper lifting techniques when moving the VSD; including properly sizing up the load, getting assistance, and using a forklift when required.
- Store in a well-ventilated covered location and preferably in the original shipping carton if the equipment will not be used upon receipt.
- Store in a cool, clean, and dry location. Avoid storage locations with extreme temperatures -4°F to 158°F (-20°C to 70°C), rapid temperature changes, high humidity, moisture, dust, corrosive gases, or metal particles.
- Do NOT store the unit in places that are exposed to outside weather conditions (i.e., wind, rain, snow etc.)
- Store in an upright position as indicated on the shipping carton.

### LOCATION

The standard YORK MV VSD is intended for indoor installations only. The cabinet is NEMA 1 rated. You should allow for 1" (2.54cm) of clearance across the back of the enclosure for units with top exhaust fans. You should allow for 18" (45.7cm) of clearance across the back of the enclosure for front/rear exhaust fans.

Ensure that the drive is positioned so that the cabinet door(s) has ample clearance, and all of the controls are accessible (72" (183cm) minimum). There should be 24" (61cm) of clearance above for top exhaust and 24" clearance across the back for front/rear exhaust.

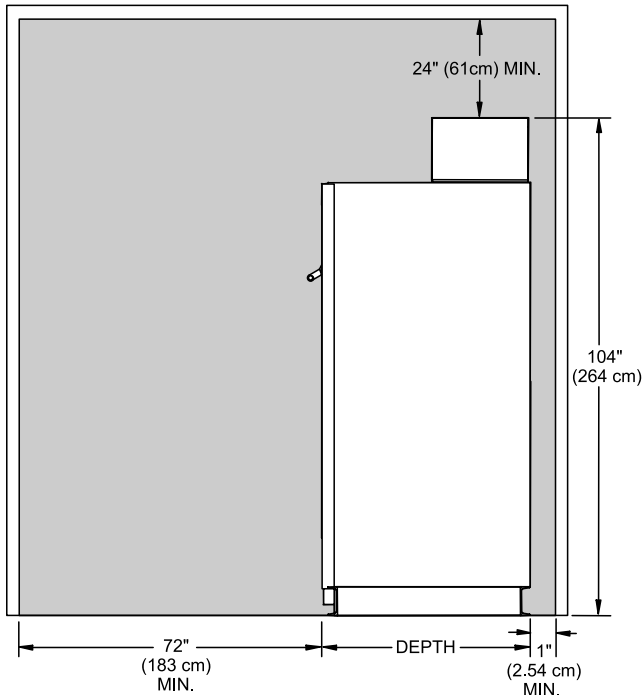

NOTES:  
See Table on Pgs. 7 & 8 for width and depth dimensions

LD12180

**FIGURE 26 - UNIT CLEARANCES**

The temperature range for operation is 32°F to 104°F (0°C to 40°C), with humidity not to exceed 95%, non-condensing. If the location is such that moisture could be permitted to condense on components inside the MV VSD, it will be necessary to add cabinet heaters to keep the moisture out. Failure to prevent condensation inside the drive cabinet could result in serious electrical failure which is NOT covered by warranty. In cases where the application is greater than 5000' (1524m) above sea level, the drive will need to be reviewed as a special quote. For additional details about de-rating the unit contact YORK marketing.

## DRIVE LIFTING AND ASSEMBLY

To move the sections use a forklift of adequate capacity. For unit weights refer to the unit model reference chart provided on pages 7 & 8. Lift the enclosure from the slots provided in the channel base on the transformer section. The inverter section is shipped with 4x4 posts attached to the bottom.

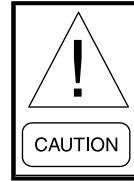

**Verify that the forks extend entirely through the section. A safety strap must be used when handling with a forklift.**

The enclosure that houses the input transformer is too heavy to be lifted by eye-bolts through the cabinet roof. For this reason the transformer cabinet is not supplied with lifting eye-bolts. This enclosure must be lifted by forks positioned under the cabinet and base of the transformer. Contact the YORK factory if there is a need to lift the transformer cabinet from above. On cabinets that are capable of being lifted from above, lifting angles and lifting eye-bolts are provided on top of the enclosure for this purpose.

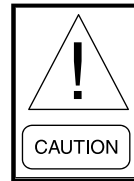

**Spreaders must be used to provide the vertical lift on single controllers to prevent eye-bolt failure. Always keep the controller upright while lifting.**

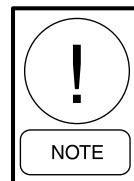

**Some enclosure sections may contain heavy or special equipment that will cause the center of gravity to be off center.**

Adjust rigging lengths to maintain the enclosure in an upright position. The angle between the lifting cables and vertical should NOT exceed 45 degrees. Ropes or cables should NOT pass through the holes in lifting angles or eye-bolts. Slings with safety hooks or shackles of adequate load rating should be used.

After the enclosure sections are in place, bolt together with 1/2" hardware, supplied then install and wire the fan assemblies. Connect the DC bus cables to the modules and plug in the control connector. Assemble the ground bus splice(s).

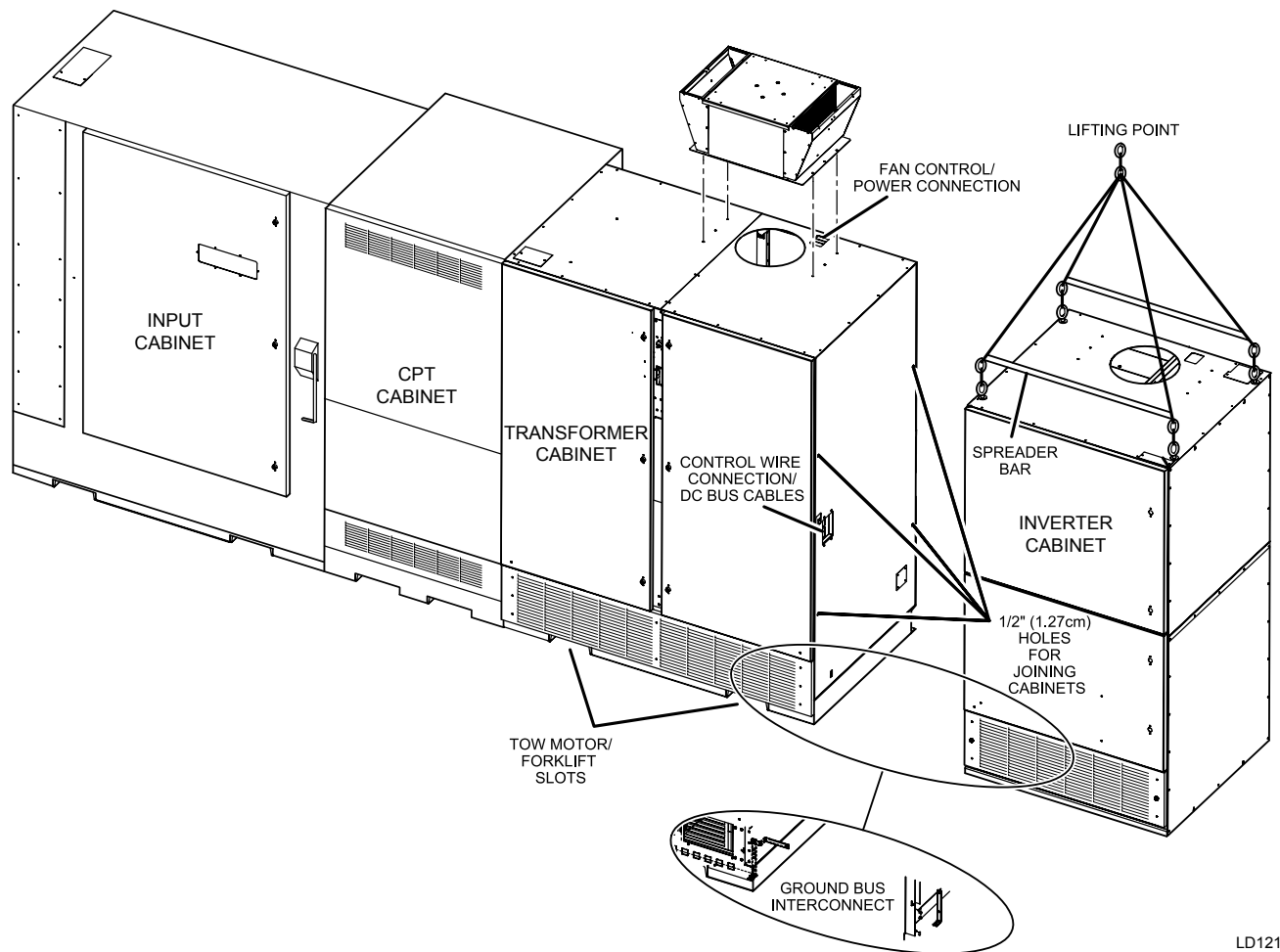

**FIGURE 27 - LIFTING AND ASSEMBLY**

### MOUNTING REQUIREMENTS

- Only qualified personnel should install this equipment.
- Install the unit in a secure upright position in a well ventilated area.
- A noncombustible insulating floor or mat should be provided in the area immediately surrounding the electrical system at the place where maintenance operations are to be performed.
- As a minimum, the installation of the equipment should conform to the NEC article 110 requirements for electrical installations, OSHA, as well as any other applicable national, regional, or industry codes and standards.
- Installation practices should conform to the latest revision of NFPA 70E Electrical Safety Requirements for Employee Workplaces.

### MOUNTING

Each shipping section must be leveled and firmly secured to a supporting foundation. Steel shims may be used for final leveling, if necessary. When three or more shipping sections are to be arranged in one continuous line-up, the center shipping section should normally be the first located.

Follow the equipment outline drawings provided with the unit to determine the location of the mounting bolt holes and any conduit locations.

Various methods may be used to anchor the enclosure to the foundation, including expandable inserts or "J" bolts embedded in concrete. The recommended size for anchor bolts is 1/2" (13mm).

## ELECTRICAL CONNECTION

The following connection recommendations are intended to ensure safe and satisfactory operation of the unit.

Cable and wire bundles that enter the MV VSD enclosure should be routed to avoid interference with moving parts. Minimum bending radius for the type of cable being used should be observed.

All access covers, barriers, partitions, etc. that are temporarily removed during installation must be replaced.



**Failure to follow the recommendations could cause harm to persons, or damage to the unit, and may invalidate the warranty.**



**Absolutely NO additional controls (relays, etc.) are to be mounted in the unit. Power and control wiring not connected to the unit should NOT be run through the unit. If these precautions are not followed electrical noise could cause malfunctions or damage the unit and its controls.**

## CONTROL WIRING

Wiring between the MV VSD and the York OptiView™ control panel consists of 6 conductors plus a shielded communications cable. The 6 conductors are for the following:

- GND – Ground
- L – 120 VAC control power line side
- 2 – 120 VAC control power neutral side
- 24 – Start signal from panel to MV VSD
- 16 – Motor controller fault signal from MV VSD contact back to control panel.
- 53 – Motor controller 120 VAC supply to dry contact in the MV VSD

In addition, the modbus cable is comprised of three conductors plus a shield. Standard 18 gauge shielded wire may be used.

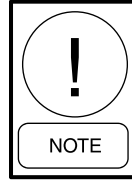

**Control wiring is NOT to be run in the same conduit with power wiring.**

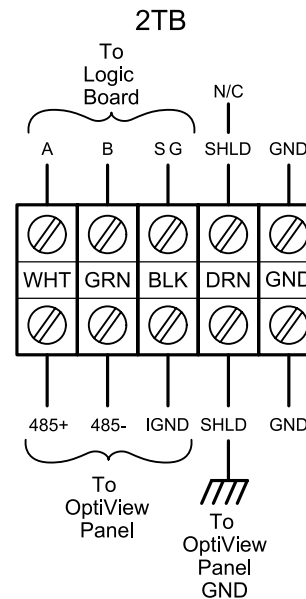

LD12236

**FIGURE 28 - MODBUS CONNECTIONS**

### POWER WIRING

Input power wiring terminals are designated L1, L2, and L3, and output power wiring terminals are designated T1, T2, and T3. Do NOT run input and output wiring in the same conduit. Connection cables must be of the correct current rating per NEC/CSA.

Input and output wiring connections are NEMA 2, which consists of two 3/8" (9.5mm) holes per phase. The contractor will need to provide crimped lugs on the ends of the wires to match the 3/8" bolt holes provided.

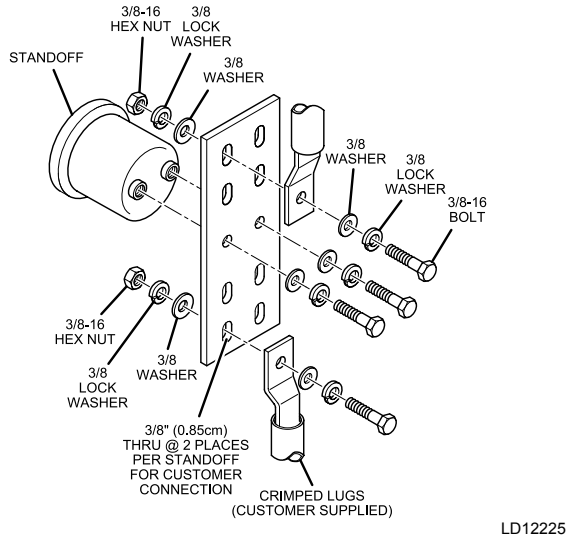

**FIGURE 29 - MOTOR LEAD CONNECTIONS**

### GROUNDING

The enclosure line-up must be grounded in accordance with the requirements of the National Electrical Code. Proper equipment grounding must be established before making any incoming power connection. The enclosure sections which are shipped separately should be connected in such a way as to ensure a continuous grounding path, using the ground bus located along the bottom of the enclosures.

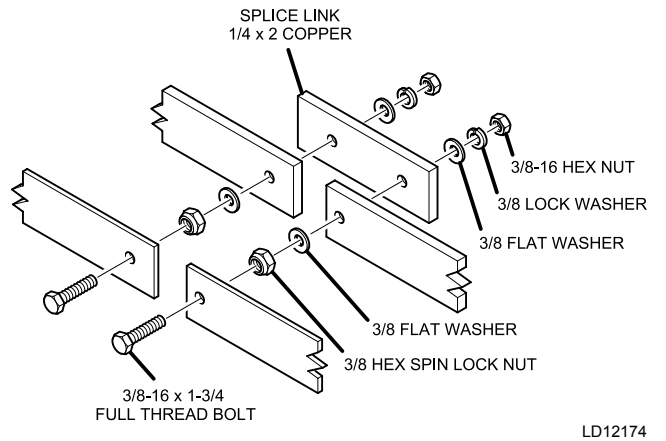

**FIGURE 30 - GROUND BUS SPLICE CONNECTION**

Each section contains a vertical ground bus extending from the main ground bus or ground pad to each controller compartment.

Special attention should be paid to protection for operating personnel, to protection of the equipment itself, and protection of sensitive transducers or control devices that are electronic in nature.

The following may be used as a general guide with regard to equipment grounding.

1. MV VSD used as service equipment for a grounded system or as a main section for separately derived system.

- The grounding electrode conductor (ground wire) sized in accordance with NEC should be run from the grounding electrode to the MV VSD ground bus or ground terminal.
  - If not already provided by the factory, a main bonding jumper should be installed from the incoming grounded connector bus (neutral) to the ground bus or designated grounding point. If a jumper is not furnished, one having size in accordance with NEC should be selected.
  - No Connection should be made to ground on the load side of any neutral disconnecting line or any sensor used for ground fault protection. No connections should be made between outgoing grounding connectors and the neutral.
  - In NO case should there be a second source of power to the MV VSD. The only source of power must be the 3-phase incoming wiring to the main isolation switch
2. MV VSD used as service equipment for an ungrounded system or as a main section for a separately derived system.
    - A grounding electrode conductor (ground wire) sized in accordance with NEC should be run from the controller ground bus or ground terminal. See also NEC Article 250 - Grounding and Bonding.
    - If the system is grounded at any point ahead of the controller, the grounded conductor should be run to the controller in accordance with NEC Article 250 and connected to the ground bus or ground terminal.
  3. MV VSD NOT used as service equipment or as a main section for a separately derived system, and used on either a grounded or ungrounded system.
    - The MV VSD frame and any ground bus should be grounded by means or equipment grounding conductors having size in accordance with NEC Article 250 and run with the main supply conductors or by bonding to the raceway enclosing the main supply conductors in accordance with NEC.
    - Ground leads should be connected to cable potheads/shields as specified by the cable manufacturer.

## OIL PUMP WIRING

Oil pump field wiring terminals are designated 67, 68, 69, and GND. Standard 14 gauge wire may be used. The following FIG. shows the connections for the Oil Pump. The 1TB terminals can be found located within the low voltage compartment at the bottom facing upwards.

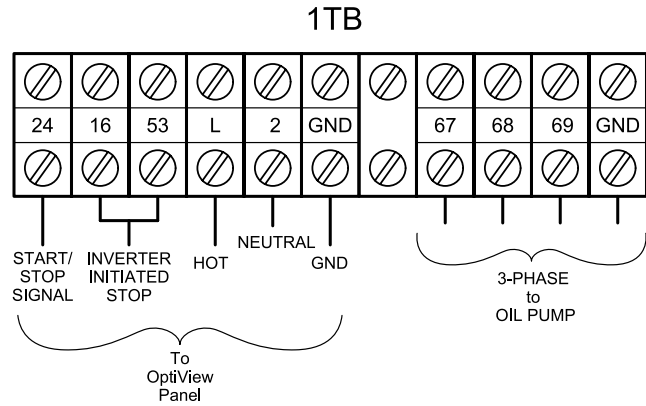

**FIGURE 31 - OIL PUMP CONNECTIONS**

## SECTION 4 - COMMISSIONING

### INITIAL COMMISSIONING



*Voltages present within this drive enclosure may be lethal! Only “qualified” individuals are permitted to commission this product!*



*The drive must be commissioned by qualified personnel only.*

### UPSTREAM PROTECTION

- Ensure that primary protection exists for the input wiring to the equipment. This protection must be able to interrupt the available fault current from the power line.
- All cable entry openings must be sealed to reduce the risk of entry by vermin and to allow for maximum cooling efficiency.
- Follow all warnings and precautions do NOT exceed equipment ratings.

### PRE-ENERGIZATION CHECK

After installation, but before energizing the MV VSD for the first time, follow the procedure below to verify that the equipment is properly installed and functional.

- There is a rating data label on the inside of each medium voltage compartment door. Verify that the MV VSD ratings properly match the system data by checking the following:
  1. Verify agreement of full load current and locked rotor current with the motor nameplate.
  2. Verify that input voltage, number of phases and frequency matches the MV VSD rating.
  3. Verify that available short circuit current of power system is less than the rated short circuit capacity of the MV VSD.
- Check connections - Although the equipment and devices have been completely tested at the factory, a final field check should be made that all electrical wiring and bus bar connections are correct and have not become loose in transit.

- All blocks or other temporary braces used for shipment must be removed.
- Before closing the enclosure, all metal chips, scrap wire and other debris left over from the installation must be cleaned out.
- If there is an appreciable accumulation of dust or dirt, the enclosure should be cleaned using a brush, vacuum cleaner, or a clean lint free brush.
- The integrity of all bus bar supports must be checked for secureness and damage.
- Care should be exercised that when covers are installed and the doors closed, no wires are pinched and that all enclosure parts are properly aligned and tightened.
- A supply of spare parts, fuses, etc. should be established.

### CONFIRMATION OF WIRING

Make the following final checks before applying power to the unit:

- Confirm that the source power is connected to terminals L1, L2, and L3. Connection of incoming source power to any other terminals will damage the unit. Refer to the equipment diagrams shipped with the unit for any special requirements.
- Verify that the power modules are properly connected and that there was no damage during shipping or handling.
- Verify that there is no loose connections or wires and that all of the required shipping split connections have been made.
- Verify all external control circuit wiring is complete and properly connected.
- The 3-phase source power should be within the correct voltage and frequency tolerances.
- The motor leads must be connected to terminals T1, T2, and T3.
- Verify that all grounding connections are properly connected.
- Make sure there are no short circuits or inadvertent grounds and tighten any loose connector terminal screws.

## DEVICE/MECHANISM CHECK

- All devices are to be checked for damage. All necessary repairs or replacements should be made.



***Do NOT energize damaged equipment that has not been properly repaired and verified.***

- Ensure that all safety signs are visible and NOT obscured.
- All switches, relays and other operating mechanisms should be manually exercised to make certain that they are properly aligned and operate freely.
- Operating mechanisms such as interlocks, switches, etc. should be checked for function as intended for protection of personnel and equipment.
- Fan overload relays should be checked to be sure they are selected and adjusted to the proper settings.
- Power circuit fuses should be verified to be selected and installed in accordance with the unit parts list. Fuses must be completely inserted in their holders.

## ELECTRICAL CHECKS

- An Electrical Insulation Test should be performed to ensure that the MV VSD and associated field wiring are free from short circuits and grounds. The preferred method is to perform a dielectric test at 2.25 times the nominal system voltage plus 2,000 volts. This should be done phase-to-ground, and phase-to-phase, with all switches and circuit breakers opened. Disconnect any devices which may have limited dielectric strength and that are not intended for this test, such as the input surge suppressors.
- The light or buzzer, or both, used to indicate breakdown should be calibrated to indicate failure with an output current between 1.5 and 2.0 milliamperes per 1,000 volts applied.



***Hazardous voltages are present during dielectric testing which can result in serious injury or death. High potential tests should be performed only by qualified personnel. Refer to safety instructions provided with the test equipment.***

- All devices must be set to their normal or OFF position before energizing incoming power.

## INITIAL ENERGIZATION

Energizing a MV VSD for the first time is potentially dangerous. Therefore only qualified personnel, as defined in the MV VSD overview section of this manual, should energize the equipment. If faults caused by damage or poor installation practices have not been detected in the pre-energization check section, major damage including personal injury can result when power is applied. Extra precaution is recommended on the initial energization of the equipment.



***Hazardous Voltage. Improperly installed, or damaged equipment will result in severe injury, death, and property loss. Correct all problems prior to energizing this equipment.***



***Only qualified personnel should energize this equipment. Proper arc-flash protective clothing and equipment must be worn when energizing medium voltage switchgear, including the isolation switch on the front of the MV-VSD.***

The equipment should be energized in sequence by starting at the source end of the system and working towards the main devices. First the main devices, then the feeder devices and then the branch circuit devices should be closed.

With all removable barriers in place and all doors closed and latched, the devices should be turned on with a firm, positive motion. Protective devices and switches that are not quick-acting should not be "teased" into the closed (or open) positions. The isolation switch handle should be moved between the OFF and ON positions in a single continuous smooth movement.

## START-UP AND TEST

Prior to releasing the drive system for regular operation after installation, the system must be adjusted and tested by qualified YORK personnel. This start-up labor is included in the sale of each MV VSD, to assure reliable and safe performance. It is important to make arrangements for such a check and that time is allowed for it.

## SECTION 5 - MV VSD LOCK-OUT / TAG-OUT PROCEDURE



*The only type of activity that may be performed on the MV VSD while the medium voltage equipment is energized involves the low voltage controls that are maintained in a cabinet section that is separate from the medium voltage section of the VSD.*



*Do not open drive output access door for any reason while drive is energized. Lethal voltages are present which may result in death or serious injury!*

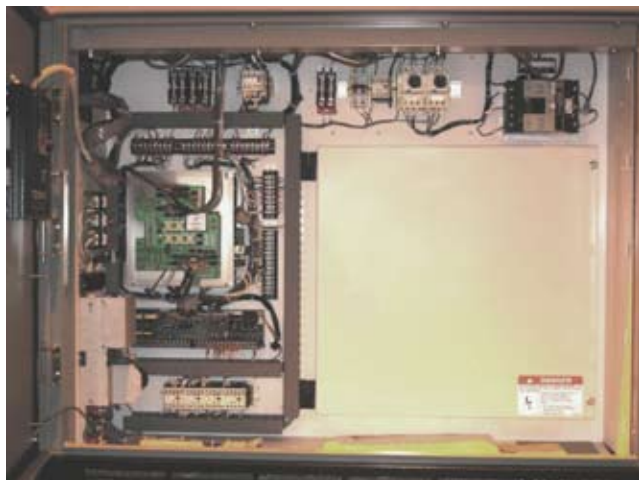

LD12185

**FIGURE 32 - ACCESS PANEL**

The VSD's low voltage section contains 120 VAC and 3-phase 480 volt circuits. If you are working on the low voltage section and there are energized 480 volts circuits, you must wear appropriate personal protective equipment (PPE) and protective clothing per NFPA 70E.

### LOCK-OUT / TAG-OUT PROCEDURE

1. **Chiller Shutdown** - Begin by locating the chiller on/off switch on the OptiView™ control panel, and turning this switch to the "OFF" position. Never turn the chiller off by the main disconnect.

If the chiller had been running, wait for the chiller to go through its shutdown sequence, including the completion of compressor post-lube. Make sure it shuts down completely.

Also, take a few minutes to examine the area surrounding the MV VSD to assure there is nothing located there that would prevent proper access or present a hazard. This includes inappropriate items that may have been stored adjacent to the MV VSD such as flammable liquids or gas, or items that may have been placed on top of the MV VSD cabinets. Be certain there is clear access to all the MV VSD cabinet doors.

2. **Disconnection of Upstream Power** - Ask an on-site electrician to de-energize power to the VSD. This is done at the upstream motor control center or power distribution panel.



*The on-site electrician will need to verify with a high voltage detector that the load side going to the VSD has been de-energized. Once this is done, the on-site electrician must place their lock, hasp and ID tag on the disconnect.*

After the lock-out has been completed, add your personal lock to the electrician's hasp attached to the upstream power source.

3. **Verify Equipment** - Before proceeding, verify that the high-voltage detector that you'll be using later in the procedure is working properly, by checking the detector in accordance with the manufacturer's test recommendation. Additionally, verify that the detector and Hot Stick are rated for the voltage that you'll be testing. Personal Protective Equipment (PPE) should also be checked to assure it is in good condition and that the expiration dates have NOT been exceeded.
4. **Approach MV VSD** - For the following steps you'll need to wear the Personal Protective Equipment (PPE) that is adequate for medium voltage and for the available fault current as determined by personnel responsible for the electrical systems within the facility where the unit is located. The PPE must conform to the requirements as set forth in NFPA 70E.

Verify that the chiller control panel is NO longer illuminated. If the control panel is still illuminated, contact the site electrician to determine if the correct distribution switch has been opened and locked out. It is also possible that a second source of power has been wired to the controls.

- This is NOT permitted, as it presents a serious danger. External power to the controls will back-feed through the unit's control power transformer and cause medium voltage to be present inside the unit even with the input isolation switch open! Do NOT proceed as long as the control panel is illuminated. The source power must be identified and disconnected.
5. **Open Isolation Switch** - Once the control panel is verified to be de-energized, proceed to open the incoming power isolation switch on the front of the MV VSD cabinet. This step continues to require medium voltage PPE as indicated in the above paragraph. Lift dent pin and pull the isolation switch handle downward in one continuous, swift motion. With the isolation switch open, use a flashlight to view the switch contacts through the window in the cabinet door, adjacent to the isolation switch. Visually verify that each leg of the input isolation switch is in the fully open position. Now lock the switch handle in the OFF position with a second hasp and padlock, place and additional lock-out tag on this lock.
  6. **Wait for Capacitors to Discharge** - Next, note the label on the cabinet that gives the discharge time for the capacitors. These capacitors keep a residual charge for a period of time after the VSD is shut down. Per , this is typically at least 15 minutes. But check the label to verify and then wait the required time. If you choose to leave the immediate area during the waiting period, be certain the area is secured so non-qualified personnel are NOT able to enter the area.
  7. **Opening Inverter Cabinet Door** - Once the required waiting time has elapsed, open the inverter section of the cabinet where the power modules are located. Do NOT remove the plastic shield that covers the internal components. Each of the three output pole assemblies has two red LED lights to identify whether or not the capacitors are charged. All six LED lights must be OFF before performing the next step. Visually inspect all of the surrounding electrical hardware in this cabinet and if anything does NOT look correct, close the cabinet door and contact your supervisor before proceeding.
  8. **Opening the Rectifier Section Doors** - Having verified the red LED's are OFF, open the side of the cabinet that contains the main disconnect, transformer, and rectifiers. Do NOT remove the plastic shield that covers the internal components. Visually inspect the location where the incoming power comes into the cabinet and verify that the sheet-metal cover is in place and that accidental contact can NOT occur. If the line side is NOT properly guarded, stop work, close the cabinet and contact your supervisor. Visually inspect all other hardware in this cabinet section, and if something does NOT look correct, close the cabinet and contact your supervisor before proceeding.
  9. **Check with "Tic-Tracer" and Hot Stick** - Using a connection less high voltage detector and Hot Stick that you tested earlier, verify that the three phases at the load side of the isolation switch are de-energized, by holding the probe end of the detector about 6 inches from each of the main fuses and then slowly moving the probe closer. If at any time the probe gives an indication of voltage being present, draw away from the unit, close the cabinet doors, and contact your supervisor. Once the 3 fuses are confirmed to be de-energized, check all other components in the cabinet to verify they are also de-energized.
  10. **Opening the Low-Voltage Cabinet Door** - Medium Voltage rated PPE may now be removed if desired, 480 VAC rated PPE is still required for the next step which involves opening the low-voltage cabinet section door. Wearing at minimum the required 480 VAC PPE, use a hand-held digital meter to check for presence of 480 VAC at the circuit breaker for the fans, and check for presence of 480 VAC at terminals 67, 68, and 69 which supply power to the oil pump on the chiller. Additionally check for presence of 120 VAC at the F1 and F2 cartridge fuses. Once all of these points are confirmed to be de-energized, the MV VSD is now locked out and the unit has been verified that it is no longer energized.

## SECTION 6 - MAINTENANCE

### GENERAL



***Voltages present within this drive enclosure may be lethal! Only qualified individuals are permitted to service this product!***

In order to ensure continued reliable and safe operation of the equipment, a program of periodic maintenance must be established. Operating and environmental conditions will dictate the frequency of inspection required. NFPA publication 70B "Electrical Equipment Maintenance" may be used as a guide for setting up the maintenance program.

### MAINTENANCE RECORD

A permanent record of all maintenance work should be kept. At a minimum, this record should include the following information on:

1. Items inspected
2. Test reports
3. Equipment condition
4. Corrective actions and/or adjustments
5. Date of work
6. Comments

The degree of detail will depend on the operating conditions.



***Contact with energized components can cause severe injury or death. Turn-off and lock-out/tag-out Primary and Control Circuit Power before servicing***

***Improper maintenance can cause serious injury, death, and extensive property damage. Only qualified personnel are to operate and service the equipment.***

***This equipment utilizes both low and high voltage for operation. Verify that all test equipment is suitable for the voltage being checked.***

### GENERAL INSPECTION

Follow the procedure outlined in section 5. After disconnecting and locking-out/tagging-out incoming power and before performing any maintenance, it is recommended that a safety ground be connected to the main power bus. After maintenance is complete, perform the checks in the Pre-Energization Check section of this manual before restoring power.

The following pages detail maintenance procedures recommended for fixed type medium voltage controllers. The information presented here is intended to cover preventive maintenance only. It does NOT cover major rework or repair. The following maintenance should be performed at least annually or more frequently depending on the operating conditions.

- Thoroughly clean the equipment, removing all dust, dirt and other accumulations. Wipe insulators clean using a clean, dry cloth. Do NOT use petroleum-based solvents or cleaners.
- Check for any signs of moisture inside the enclosure. If there are signs of water entering the enclosure, eliminate the source. Thoroughly dry any insulation which shows signs of wetness and repeat the dielectric test procedure. Replace insulators, if necessary.
- Checking and tightening of electrical connections
- Checking of fuses and fuse connections
- Proper installation of any removable barriers
- Check for any signs of rusted or corroded parts.
- Check for free movement of all moving parts and mechanisms. Lubricate if necessary with B9 grease (031-02777-000).
- Vacuum Contactor maintenance as outlined in this publication.



***Grease is conductive. Do NOT apply grease to electrical insulation.***

Maintenance and inspection is a particularly effective means to help prevent failures and reduce down time. Creating equipment specific inspection and maintenance checklists can help to perform maintenance and inspections effectively.

### Daily Inspections

Daily inspections consist mainly of visual inspections of the following items. These observations should be made with all of the cubicle doors closed and safety covers installed. Any abnormalities discovered should be immediately be repaired.

1. Check the temperature, the humidity, the presence of corrosive or explosive gases, and the presence of dust in the area.
2. Check for any abnormal sound or vibration of the reactor, transformer, or cooling fans.
3. Check for abnormal odors such as the smell of burning insulating materials.

### Regular Inspections

Carry out regular inspections with power off, locked-out/tagged-out, and with confirmation that the bus voltage is completely discharged. Use power lock-out/tag-out procedures on the disconnecting means in accordance with applicable electrical codes before performing any drive maintenance.

The first thing to do in maintenance is cleaning. Cleaning should be carried out according to the conditions of the equipment. Before starting, turn off power supply and check that the main circuit voltage is reduced to 0 as outlined in Section 5 of this manual. Clean dust with a vacuum, and clean dry cloths.



***Excessive air pressure when blowing out equipment may damage parts and wiring. Do NOT use solvent to clean the drive.***

Substances stuck to the circuits, which cannot be removed by blowing, should be wiped away using a clean cloth. As a basic rule, cleaning should start from the upper parts and end at the lower parts.

## MAIN COMPONENTS

1. Cooling Fan - Check for any abnormal airflow, increased fan noise, etc.
2. Air Filter - Visually check if the air filter is clogged. Gently tap outside the room to remove loose dust. To remove caked on dirt use water and a gentle detergent, rinse with clean water and dry. Otherwise replace with a new one. Cleaning with solvents is NOT permitted. After cleaning, allow filters to air-dry for 24 hours, and then check to assure that there is no droplets of water remaining which could get carried into the MV VSD by the fans.
3. Main Circuit Parts and entire Cubicle - Check to see if dust is stuck to the cubicle interior or if there is any discoloration, heat generation, abnormal sound, leakage, odor or damage with the reactor, transformer, contactors, cables and connections, fuses, capacitors, lightning arrestors, and resistors. Check to see that no wires or mounted parts are broken, disconnected, loose or damaged. High voltage standoffs, insulators and cable can be cleaned with isopropyl alcohol.
4. Check the protection functions for proper operation (door switches, interlocks, etc.)
5. Check the insulation resistance of the medium voltage circuits.

### Cautions on Handling Printed Circuit Boards

- All maintenance work on the board should be carried out at least 15 minutes after all power supplies are turned off to allow the capacitors on the board to discharge.
- When removing the board, disconnect all the connectors and wires and remove the mounting screws from the upper part of the board first. At this time, be careful not to drop the boards or screws. When setting the board down, place it on a static free surface. Be careful not to damage any components.
- When attaching the board, do so in the order opposite to the removal procedure. Be sure that all of the connectors and wires are connected correctly.
- New boards are shipped in an anti-static bag. Use this bag to properly store the boards. The anti-static coating is only applied to the interior of the bag.

## ELECTRICAL JOINTS

- Examine all visible terminals and joints for any signs of overheating. An overheated connection will appear discolored. Be suspicious of any conducting joint which has a darker color than other similar joints.
- Check all bolted connections for proper tightness. The proper torque is dependent on the size of the hardware and the materials used. As a general guide, use the following torque values:

Thread Size	Torque	
	(ft-lbs)	(kgf-cm)
1/4-20	4-6	55-83
5/16-18	10-15	138-207
3/8-16	20-30	276-415
1/2-13	40-50	553-691

The above values apply to metal-to-metal joints. When torquing a bolt threaded into an insert molded into a plastic part, use approximately 2/3 the torque value shown above.

## MAIN FUSES

- Check the condition of the back stab terminals on the cartridge for any signs of damage or discoloration. If there is any excessive build-up of dirt or other foreign material, wipe clean and lubricate with a light coat of B9 grease, making sure that no grease gets on the insulated fuse housing.
- Wipe off any dust or dirt which may have accumulated on the inside or outside of the power fuse cartridge or on the vacuum contactor housing.
- Check the power fuses for any signs of discoloration. A fuse barrel which appears darker than others indicates overheating. Possible causes of fuse overheating, other than load problems, are misapplication, loose fuse clips, or damaged fuses.
- Check the torque on the bolts which clamp the fuse clips to the fuse ferrules. The proper torque value is 4 ft-lbs.
- Check the fuse barriers for cleanliness and proper positioning. There are four vertical barriers located between and outside fuses. A fifth angle shaped barrier is positioned horizontally across the four barriers toward the back (See *FIGURE 5*).

## VACUUM CONTACTOR

The following maintenance and inspections are recommended to maintain the performance level and extend the operational life of the vacuum contactor.



***Before conducting any maintenance and inspections, make sure that all power is turned off.***

### Vacuum Interrupter

Check the upper and lower flanges and the interrupter shaft to see if they are contaminated or corroded. If contaminated, use a clean cloth and rubbing alcohol. If corroded, replace with a new interrupter.

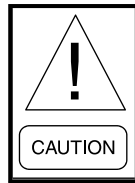

***Avoid touching the ceramic surface. Skin oils may harm the silicon varnish on the vacuum interrupter.***

Check the main contact wear in the vacuum interrupter. If the wear gauge (2.7mm) can be inserted, replace the interrupter.

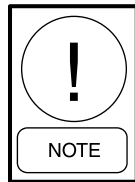

***This check is to be made with the contactor closed.***

Check vacuum in the Vacuum Interrupter. If there is a vacuum failure, this can be confirmed by pushing down on the insulating flange below the vacuum interrupter. If the interrupter shaft can be easily moved, then the interrupter has lost vacuum.

## Bearing

Check for any loose mounting bolts, tighten if necessary, and torque the M6 bolts to 4 ft-lbs (55 kgf-cm).

## Closing Coil

Check for any discoloration. If yellow (gold) the coil is acceptable for continued use. If the coil is dark brown or black, replace with a new coil.

## Latch Mechanism

Check that the holding latch reliably engages. To manually close the latch, hold the central area of the rotating shaft with a wrench and operate it.

Check the condition of the roller, it should be smooth. Lubricate the rotating parts with molybdenum disulfide or gear lubricant.

## Auxiliary Switch Contacts

Verify that there is remaining auxiliary shaft travel (approx. .090"-.098" (2.3-2.5mm)). Check for burnt or worn contacts, replace if burnt or worn.

Check if Auxiliary Switch is mounted at an incline or if mounting plate is loose. If inclined or loose, correct and tighten switch.

## OPERATION CHECKS

In a no-load situation, electrically operate the contactor through 20 operations to confirm normal operation.

## Isolation Switch

The Isolation Switch provided in each controller is a bolted pressure type device. It is designed to maintain proper adjustment and contact pressure over its mechanical life of 10,000 no-load close-open cycles. Under normal operating conditions, no maintenance is required other than periodic inspection and cleaning.

Open and close the switch and verify that no excessive force is required. Observe that the line terminal shutter opens and closes properly. Lubricate the moving parts of the handle mechanism and, if necessary, apply a light coat of grease (B9) to the inside contact surfaces of the switch blades.

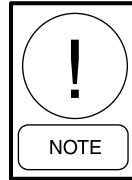

***Grease is conductive. Do NOT allow grease to contact the switch housing or the insulating shutter.***

Examine the current carrying switch blades for any sign of discoloration due to overheating.

Each bolted pressure switch blade assembly is pre-torqued and adjusted to the proper settings at the factory.

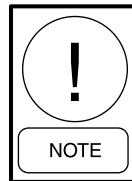

***Do NOT attempt to change the torque settings or replace individual parts of this assembly in the field.***

## Switch Handle Mechanism and Interlock

The handle mechanism which operates the isolation switch is adjusted at the factory and under normal operation requires no further adjustment.

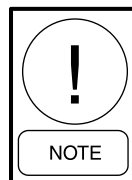

***Moving joints of all linkages should be occasionally lubricated with a light coat of grease (B9).***

## CONTROL POWER TRANSFORMER

- Wipe off the surface of the primary fuses mounting plate and the control power transformer.
- Check the condition of the primary fuses and fuse clips. Check all screws for tightness.

## POWER MODULE REMOVAL / INSTALLATION



*Disconnect power and wait 15 minutes to ensure the capacitors are discharged before performing inspection or maintenance.*

*Improper handling of the fiber optic cables and connectors may cause drive failure due to problem transmitting signals.*

*Take care not to disturb fiber optic cables when handling power modules.*

*Use module lifting attachment and a lifting device of adequate lifting capacity.*

### Power Module Removal

1. Disconnect and remove AC neutral bus.
2. Disconnect power cables ACL, P, C, & N.
3. Remove control wiring cover (two "A" bolts).
4. Disconnect control signal cable and 120VAC supply cable from module.
5. Free slide tray by removing the ("B") bolt located behind the control wiring cover.
6. Pull slide tray out until the slides lock.
7. Remove the 4 ("C") bolts which secure the module to the tray.
8. Using the module lifting attachment, lift module from tray.

### Power Module Installation

1. Pull slide tray out until slides lock.
2. Using module lifting attachment, place module on tray.
3. Secure module to tray with four ("C") bolts.
4. Press slide release buttons and slide module into compartment.
5. Reinstall ("B") bolt to secure tray into position.
6. Reconnect control signal cable and 120VAC supply cable to module connectors.
7. Reinstall control wiring cover and secure with two ("A") bolts .
8. Reconnect power cables ACL, P, C, & N.

9. Reinstall AC neutral bus.
10. Torque all power connections (5/16-18 thread) to 10-15 ft-lbs (138-207 kgf-cm).

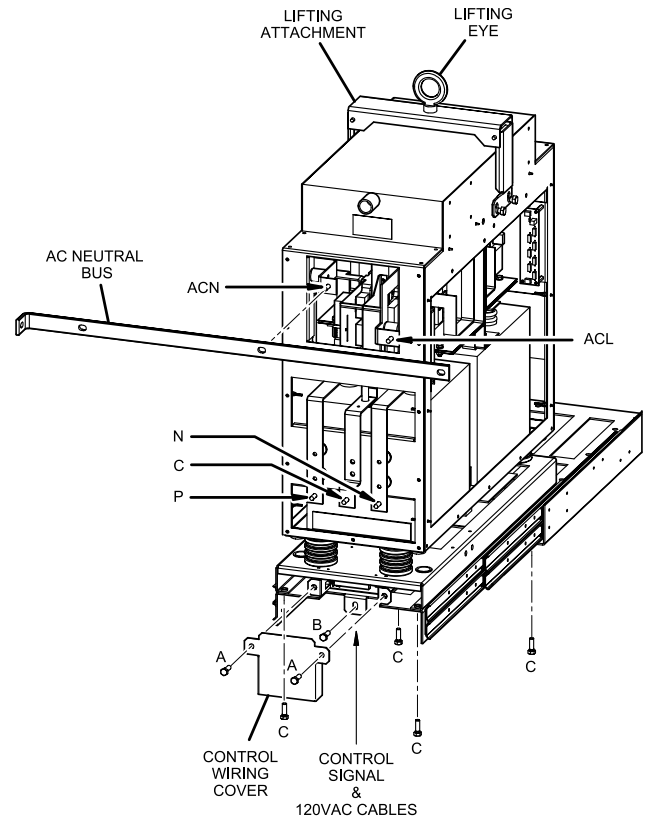

LD12159

**FIGURE 33 - POWER MODULE**

### MAINTENANCE AFTER A FAULT CONDITION

The following covers procedures to return to service a MV VSD which has been required to interrupt a load side short-circuit or ground fault. These procedures are not intended to cover devices such as wiring and motors, which may also require attention.

In an installation which has been properly coordinated and in service prior to a fault, the opening of the current limiting power fuses in the controller indicated a fault condition in excess of operating overload. This fault condition must be corrected and necessary repairs made to the load circuit before re-energizing the MV VSD.



*The following inspection and repair procedures should be carried out by qualified personnel only.*

***Hazardous voltage. Turn off and lock -out/tag-out primary and control circuit power before any inspection or testing.***

### Enclosure

Check the condition of the enclosure for any signs of bowing or deformation. Check the condition of the doors and latches for any damage.

Any substantial damage to the enclosure, such as deformation, displacement of any parts or burning, indicates a problem within the MV VSD which requires major reconditioning or complete replacement of the MV VSD components or assemblies.

### Isolation Switch

The external operating handle must be capable of opening the switch. If the handle fails to open the switch or if visual inspection after opening indicates deterioration beyond normal wear and tear, such as overheating, pitting of blades, insulation breakage or charring, the switch must be rebuilt or replaced.

### Power Fuse Cartridge

Check the condition of the power fuse clips, mounting hardware, bus stabs and insulating bases. Any deterioration of these components requires replacement of the damaged parts.

### Terminals and Internal Conductors

Indication of arcing damage or overheating, such as discoloration or melting of insulation, requires replacement of the damaged parts.

### Vacuum Contactor

Check for any signs of arcing damage to the insulating housing.

## EQUIPMENT REPAIR

Be sure to use only the renewal parts specified by YORK /Johnson Controls. Parts other than specified by YORK may not demonstrate the stipulated performance, but also effect the safety. If spare parts are not available, contact your local YORK/Johnson Controls representative to order them or ask for replacement of parts.

This equipment includes parts that need to be replaced periodically. It takes time to deliver the renewal parts, so order them as early as possible, to eliminate as much down time as possible.

1. The Power Modules have been designed for easy replacement as a unit. Individual parts should not be removed from or installed on the power module assemblies. Modules that have failed or are believed to have failed should be returned to the factory for evaluation, repair, and testing. Refer to the information label on the inside of the power module compartment door for instruction on replacing a power module.
2. Prepare necessary tools and drawings, etc. before starting the work.
3. Be careful not to damage any other parts when removing any parts.
4. Do NOT make wrong connections when changing parts. Put marking, etc. if necessary.
5. Before restarting the unit after changing any part(s) verify that all connections are correct.
6. Use the correct tools necessary when tightening screws, bolts, and nuts.
7. Special care is required when handling heavy equipment.
8. When the work is completed, make sure that no tools or other foreign materials are left in the equipment.

## RETURN TO SERVICE

Before returning the controller to service, repeat the procedure defined in the pre-energization check section of this manual.

## SECTION 7 - TROUBLESHOOTING

When a fault occurs, before resetting the MV VSD, seek to understand the cause of the fault message. It may be unsafe to restart if a component or motor has failed. Every effort should be made to determine the cause of the fault and to correct any problems before attempting to restart the system.

To do this, it is necessary to record and evaluate the phenomena and conditions of the fault in detail from both electrical and mechanical standpoints. Collect as much data as possible on the following items to determine the operational situation when the fault occurred.

1. If power is still applied to the MV VSD and OptiView™ panel record the fault message shown on the OptiView™ panel at the moment the fault occurred. Additionally, access and record the history details from the history screen of the OptiView™ panel. If power is NOT still applied to the panel, continue through the other items on this list, and then refer to the addendum below, titled "If power is removed or fuses are blown".
2. **Collect trace back data-** Record the trace back data by PC (option), if power is still applied.
3. **Operation different from ordinary operation-** Check if there was anything that affected the input power supply of the equipment at the moment the fault occurred (for example, powering-on of large-capacity equipment which is connected to the common AC power supply or short-circuits).
4. **Power failure-** Check if the input power supply of the equipment was disconnected at the moment the fault occurred (for example, if the line of the AC power supply was switched or if the breaker was turned off and back on again).
5. **Load condition-** Check if the load was drastically changed at the time of the fault.
6. **Operation-** Check to see if any changes in the process or chiller were made by the operator at the time of the fault.
7. **Installation environment-** Check if there was any abnormal ambient conditions present in the electrical room at the time of the fault or before the fault.
8. **Changes-** Check if there were any changes to other equipment around the drive or machinery.

For example, if some electrical work was carried out on or around the equipment.

9. **Lightning-** Check if there was any lightning strikes in the area.
10. **Abnormal sound, odor-** Check if there was any odor or abnormal sounds around the equipment at the time of the fault.

Understanding the conditions before and during the fault can help to determine whether the fault is attributable to factors inside or outside of the drive. Further, this information becomes an important clue to determine the cause of intermittent faults. It is important to keep a precise record of faults.

### IF POWER IS REMOVED OR FUSES ARE BLOWN

Before proceeding through this instruction, be certain you have followed through all the items on the 10-point list above, and have recorded answers to all the questions given.

It is possible to power-up the OptiView™ control panel alone by applying 120 VAC from a separate outside source.



*Extreme caution must be taken to assure that power does not back-feed through any step-down transformer, causing high voltage to be produced on the primary of any transformer!*

The power to the MV VSD must first be de-energized, locked out and tagged out. Furthermore the isolation switch on the MV VSD must be opened, locked out and tagged out.

In the OptiView™ control panel, locate wires L, 2, 16, 24, and 53 that go from the panel to the MV VSD, and remove each wire from the terminal block, pulling the wires back out of the way. Attach a 120 VAC line cord to terminals L, 2, and ground – with the black wire going to L, the white wire going to 2, and the green wire going to G or ground. Plug this cord into an extension cord and 120 VAC outlet. The OptiView™ panel should boot up upon application of 120 VAC. If it does not boot up, proceed to troubleshoot the panel.

With the OptiView™ panel powered up and initialized, the most recent fault will most likely be “Control Panel - Power Failure” as a result of the power being removed from the control panel. Review the most recent histories and determine which ones apply to the chiller shutdown, based on date and time. Select the details for the applicable fault or faults, and scroll down through the data. It is helpful to record this data, and if a printer is available, it is best to print out the data.

It is also possible to power up the logic of the MV VSD to optionally access the trace back data stored in the MV VSD logic at the time of the fault. The same extreme caution must be taken to assure there is no back-feed of power. Once again, upstream power must be disconnected as described above. The MV VSD isolation switch must be open, locked out and tagged out as well.

Locate the control power circuit breaker, MCB2, and open this breaker. Then locate connector CON1 on the low-voltage power supply mounted on the left wall of the low-voltage section of the MV VSD. Assure that there is NO voltage present at this connector. Disconnect the three wires at CON1, making sure the wire labels are clearly identified so that they can be properly re-connected later.

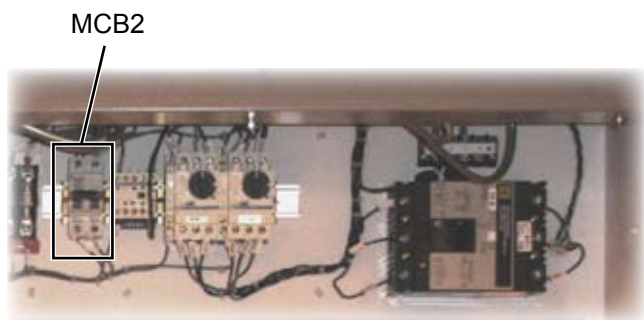

LD12185

**FIGURE 34 - CONTROL POWER CIRCUIT BREAKER**

Using a 120 VAC line cord, connect the hot wire to pin 3 of CON1, the neutral wire to pin 2 of CON1, and the ground wire to pin 1 of CON1 at the input to this power supply. Plug the line cord into an extension cord and wall outlet. This will power up the logic of the MV VSD, and will permit the data on the keyboard/display to be viewed.

## MV VSD INITIATED SYSTEM SHUTDOWN

The MV VSD may initiate a system shutdown. If a MV VSD initiated shutdown occurs, a snapshot of the MV VSD status parameters will be taken just prior to the shutdown, and this snapshot will be available for transmission to the control panel, together with the root cause of the MV VSD initiated shutdown as outlined in the communications map. Non-volatile memory, with a minimum lifetime of 5 years will be used to store status information in the event of a unit shutdown followed by power loss. An Inverter Initiated Stop (IIS) contact located within the MV VSD will open if a MV VSD initiated shutdown occurs.

## MV VSD FAULT MESSAGES

The MV VSD will initiate a shutdown of the system under the following conditions:

- **Initialization failed** - After power has been applied to the system the control panel will attempt to establish communications with the MV VSD using the 3-wire plus shield communications link. The control panel will attempt to establish communications with the MV VSD ten times during initialization. If establishment of the communications link is unsuccessful, the control panel will prohibit a system start, initiate a cycling shutdown and the control panel will display the message “MV VSD - INITIALIZATION FAILED”.

During initialization the MV VSD will transmit Hp and Voltage codes to the Control Panel. These codes will provide the Control Panel with the Hp and Input Voltage ratings for display purposes. If valid Hp and Voltage codes are not received upon initialization, the unit will prohibit a system start, initiate a cycling shutdown, and the control panel will display the message “MV VSD - INITIALIZATION FAILED”.

In addition, upon receipt of a Run signal from the control panel, the drive will perform an operational check of the DC Current transformers monitoring the current flow in the conductors attached to output terminals A and C.

If the drive determines that the transformers are not operational, the unit will prohibit a system start, initiate a cycling shutdown and the control panel will display the message “MV VSD - INITIALIZATION FAILED”.

- **Serial Communications** - The drive will initiate a cycling shutdown and the system control panel will display the message “MV VSD - SERIAL COMMUNICATIONS” if the drive does not receive legitimate communications packets from the control panel after ten successive attempts to communicate data, once initialization has been successfully completed. Similarly the System Control Panel will initiate a cycling shutdown and the System Control Panel will display the message “MV VSD - SERIAL COMMUNICATIONS” if the panel does not receive legitimate communications packets from the drive after ten successive attempts to communicate, once initialization has been successfully completed. All status data will display "XXX" during a serial communications loss.
- **Pre-charge Low DC Bus Voltage** – The System Control panel will provide a pre-charge signal to the drive via the serial communications link. Following receipt of the pre-charge command, the drive will enter the pre-charge interval. During the pre-charge interval the input Main Vacuum Contactor will close and the pre-charge contactor, which shunts an input inductor, will remain open. During the pre-charge interval, all of the DC Link voltages are monitored, and when the minimum value of all DC Link voltages reaches a level of 1238V (75% of 1650 VDC) the bypass contactor closes.

During the pre-charge interval all DC bus voltages will be compared to a voltage threshold level of 330VDC (20% of 1650VDC) 0.5 seconds after initiation of pre-charge. If all DC bus voltages do not meet or exceed the 330VDC threshold, the unit will prohibit a system start, initiate a cycling shutdown and the control panel will display the message “MV VSD – PRECHARGE – LOW DC BUS VOLTAGE”.

- **Pre-charge DC Bus Voltage Imbalance** – The System Control panel will provide a pre-charge signal to the drive via the serial communications link. Following receipt of the pre-charge command the drive will enter the pre-charge interval. During the pre-charge interval the input Main Vacuum contactor will close and the pre-charge contactor, which shunts an input inductor, will remain open.

During the pre-charge interval, all of the DC Link voltages are monitored, and when the minimum value of all DC Link voltages reaches a level of 1238V

(75% of 1650 VDC) the pre-charge contactor closes. During the pre-charge interval the absolute value of the difference between the positive and negative bus voltages on all phases must remain within a range of 0VDC to 248VDC (15% of 1650VDC). If the absolute value of this difference exceeds the range continuously for a time period of 3 milliseconds, the unit will prohibit a system start, initiate a cycling shutdown and the control panel displays the message “MV VSD – PRECHARGE – DC BUS VOLTAGE IMBALANCE - XY”, where X denotes the Power pole phase location (A, B or C) and Y denotes the location of the cell within that phase (U, upper or L, lower).

- **Pre-charge Lockout** - If the unit fails to make pre-charge, the pre-charge signal will be de-asserted for a time period of 10 seconds. Following this 10-second period, pre-charge will again be initiated. The unit will attempt to make pre-charge three consecutive times. If the unit fails to make pre-charge on three consecutive tries the unit initiates a safety shutdown and the control panel displays the message “MV VSD – PRECHARGE LOCKOUT”. In order to initiate pre-charge again, the control panel’s rocker switch must first be placed into the STOP/RESET position. This function is performed by the system Control Panel.
- **Run Signal** - Upon receipt of either of the two run commands (digital communications Run signal or hardwired 120 VAC Run signal), a 5 second timer commences timing. If the missing run signal is not asserted within the 5-second window the MV VSD unit initiates a cycling shutdown and the control panel displays the message “MV VSD – RUN SIGNAL”.

Although this message can be generated by either run signal being missing, it is almost always due to the loss of the hardwired signal. This is because the loss of the digital communications most likely will cause an initialization failure or serial communications message.

- **High DC Bus Voltage** – All DC bus voltages are continuously monitored and compared to an over-voltage trip level of 2063VDC (125% of 1650VDC). If any DC bus voltage exceeds this level, the unit initiates a cycling shutdown and the control panel displays the message “MV VSD – HIGH DC BUS VOLTAGE - XY”, where X denotes the Power pole phase location (A, B or C) and Y denotes the location of the cell within that phase (U, upper or L, lower).

- **LowDC Bus Voltage** - All DC bus voltages will be continuously monitored and if any one of the voltages drops below a threshold level of 1238VDC (75% of 1650VDC) continuously for a time period of 30 milliseconds, the unit will initiate a cycling shutdown and the control panel will display the message “VSD - LOW DC BUS VOLTAGE”.
- **DC Bus Voltage Imbalance** - The absolute value of the difference between the positive and negative bus voltages on all phases will remain within a range of 413VDC (25% of 1650VDC). If the absolute value of this difference exceeds the range continuously for a time period of 3 milliseconds, the unit initiates a cycling shutdown and the control panel will display the message “MV VSD – DC BUS VOLTAGE IMBALANCE - XY”, where X denotes the Power cell phase location (A, B or C) and Y denotes the location of the cell within that phase (U, upper or L, lower).
- **High Instantaneous Current** - Two of the three output lines (T1 & T3) to the motor are continuously monitored via two DC current transformers within the drive. The third phase (T2) is derived. The unit’s three phases of instantaneous output current are continuously compared to an instantaneous limit of 233% of the drive’s 100% FLA rating (see the following table). If this peak instantaneous current trip limit is exceeded, the unit will initiate a cycling shutdown and the control panel displays the message “MV VSD – HIGH INSTANTANEOUS CURRENT”.
- **Gate Driver** - The unit contains three inverter power poles, one per output phase. Each inverter power contains IGBT gate driver control boards. These boards monitor the saturation voltage appearing across IGBT’s #1 & #5 (two upper most in the cell) and #4 & #8 (two lower most in the cell) while gated on, and the isolated gate driver power supply. If the IGBT’s saturation voltage exceeds a prescribed limit, the gate driver will make the determination that a short circuit is present. This in turn will cause the unit to initiate a cycling shutdown.

In addition, if the isolated power supply level falls below a predetermined limit a cycling shutdown will be initiated. The control panel will display the message “MV VSD – GATE DRIVER - XYZ”, where X is either A, B or C corresponding to the unit’s inverter power cell connection to output terminals T1, T2 and T3 respectively, Y denotes the location of the IGBT in the pole in relation to its connection, either to the internal neutral connection of the poles or to the motor terminal (N, neutral, indicates connection to the neutral, M, motor, indicates connection to the motor terminal) and Z denotes the location of the device relative to the internal neutral connection (U, upper - #1 or #5 or L, lower - #4 or #8).

- **High Inverter Baseplate Temperature** - The unit will contain three heatsink assemblies within the three inverter power phase bank assemblies. The heatsinks will each contain a single Klixon® temperature sensor. All inverter heatsink temperatures are compared to a prescribed limit of 175°F (+/- 7°F) 79°C (+/-4°C) .

If this limit is exceeded the unit will initiate a safety shutdown and the control panel will display the message “MV VSD – HIGH PHASE X INVERTER BASEPLATE TEMPERATURE”, where X is either A, B or C corresponding to the power device connected to output terminals T1, T2 and T3 respectively. The units Klixons® resets when all inverter heatsink temperatures fall below their reset limit of 145°F (+/- 10°F) 63°C (+/-5.5°C). In order to initiate restart, the control panel’s rocker switch must first be placed into the STOP/RESET position.

**TABLE 3 - OVER-CURRENT TRIP**

HP RATING	PEAK INSTANTANEOUS OVER CURRENT TRIP 4160V OUTPUT MODELS
500	145
600	173
700	203
800	231
900	261
1000	289
1250	362
1500	434
1750	506
2000	579
2250	639
2500	723

- **Single Phase Input Power** - The drive monitors each of the three phase line-to-line voltages to the drives input terminals on a cycle-by-cycle basis. If the RMS voltage of any of the three inputs drops below 75% of the drives nameplate voltage rating, the unit initiates a cycling shutdown and the control panel shall display the message “MV VSD - SINGLE PHASE INPUT POWER”.
- **105% Motor Overload Current** - The overload threshold and timer functions reside in the drive. A comparator will compare the average of the three phase currents against 1.05 times the 100% Job FLA limit. If the average of the three phase currents exceeds the limit continuously for forty seconds, the unit initiates a safety shutdown and the control panel displays the message “MV VSD - 105% MOTOR OVERLOAD CURRENT”. In order to initiate restart, the control panel’s rocker switch must first be placed into the STOP/RESET position.
- **Input Power Supply** - The 120 VAC control supply that feeds the various DC power supplies powering the MV VSD controls circuitry will be continuously monitored. If the 120 VAC control supply drops to a nominal trip threshold of 84 VAC, the unit initiates a cycling shutdown and the control panel displays the message “MV VSD – INPUT POWER SUPPLY”.

In addition, the input voltage to the drive is monitored using two potential transformers connected line-to-line across the input of the unit’s power transformer. If the cycle-by-cycle RMS value of the transformers input voltage drops to a level of 70% of the nameplate voltage rating of the drive, the unit initiates a cycling shutdown and the control panel displays the message “MV VSD – INPUT POWER SUPPLY”.

- **Motor or Starter Current Imbalance** - When the average of the three output phase currents exceeds 40% of the 100% Job FLA/RLA, the % Output Current Imbalance is calculated using the following equations:

$$[\text{cIa-Iave c} + \text{cIb-Iave c} + \text{cIc-Iave c} / \{2\} \{\text{Iave}\}]$$

$$[100]; \text{Iave} = \{\text{Ia} + \text{Ib} + \text{Ic}\} / 3.$$

If the % Imbalance exceeds 30% continuously for 45 seconds the unit initiates a safety shutdown and the control panel displays the message “MOTOR OR STARTER – CURRENT IMBALANCE”. The imbalance fault is disabled when the

average of the three output phase currents drops below 40% FLA. This function resides in the System Control Panel.

- **Power Transformer High Temperature** – The input power transformer will be supplied with three temperature sensor Klixons® wired in series, set to trip at 200°F (Hammond as transformer manufacturer) or 190°F (Hitran as transformer manufacturer). If any one of the three input power transformer Klixons® open, the unit initiates a safety shutdown and the control panel displays the message “MV VSD – POWER TRANSFORMER HIGH TEMPERATURE”. In order to initiate restart, the control panel’s rocker switch must first be placed into the STOP/RESET position.
- **Main Control Board Fault** – If an internal fault is determined to be present on either the Master or Slave CPU’s located on the drives Main Control board (watchdog trip) or if the programmable logic device has failed (PLD trip) or if a system configuration or parameter error is detected or if a drive side communications board CPU error or a drive side communications board transmit error or a master station communication transmission error is detected, the unit initiates a safety shutdown and the control panel displays the message “MV VSD – MAIN CONTROL BOARD FAULT”.
- **High Output Frequency** – The fundamental frequency of the drives output voltage is measured by monitoring the fundamental frequency of the control signals being sent to the gate driver controls. The fundamental frequency detected will be compared to a threshold of 65 Hz for 60 Hz units and 55 Hz for 50 Hz units. If the frequency limit threshold is exceeded, the unit initiates a safety shutdown and the control panel will display the message “VSD – HIGH OUTPUT FREQUENCY”.
- **Ground Fault** – During startup and while running the drive will monitor the peak value of the current being conducted (via a DC current transformer) through a high impedance earth referencing resistor tied between the neutral connection of the three inverter power assemblies (which are connected in a WYE) and the earth (ground) lug. If the ground current continuously exceeds six milliamperes for 200 milliseconds, the control initiates a safety shutdown and the system control panel displays the message “MV VSD – GROUND FAULT”.

- **Contactors Fault** – Auxiliary contacts are supplied to both the input contactor and the input disconnect switch. If the auxiliary contact for the input contactor is not in the proper state (Pre-charge Contactor Open Fault), or if the auxiliary contact for the input disconnect switch is not in the proper state (Input Contactor Open Fault) the drive initiates a safety shutdown and the system control panel displays the message “MV VSD – CONTACTOR FAULT”.
- **Loss of Cooling Fan** – The unit contains dedicated fan motor thermal overloads for each of the cooling fan motors used within the drive. The drive also contains a voltage sensitive relay applied to the cooling fans power source. This relay contains a normally open contact, which closes when the fan voltage is above a minimum threshold (60% of nominal). The cooling fan’s motor starter also includes an auxiliary contact that opens when the starter is in the manual “off” position.

The motor starter also includes thermal overload protection that must be manually reset, and opens the motor starter auxiliary contact when tripped. If any one of the fan motor thermal overloads trip, the voltage supplied to the fans is below the minimum threshold or the manual fan motor starter is in the “off” mode or its thermal overload is tripped, the unit initiates a cycling shutdown and the control panel displays the message “MV VSD – LOSS OF COOLING FAN”.

The unit remains tripped while the motor starter overloads are tripped, the starter is in the manual “off” position, or the motor thermal overloads are tripped. The unit automatically resets following motor cool down, if tripped by the motors internal thermal protection, permitting the system to automatically restart.

- **Interlock Fault** – All doors that provide access to the areas that contain medium voltage are either mechanically interlocked via the input disconnect switch, or they contain micro-switches to detect an open door. The micro-switches act as door interlocks and drop out the input supply vacuum switch if the doors are opened with medium voltage applied to the unit.

In addition the drives display, which is mounted on the inside of the low voltage compartment, contains a display interlock switch that contains the capability to prohibit the unit from be started by an external run signal. If the micro-switches for the doors are not closed and control power is supplied or if the display interlock switch is not closed, the drive initiates a safety shutdown and the system control panel displays the message “MV VSD – INTERLOCK FAULT”.

## SI METRIC CONVERSION

The following factors can be used to convert from English to the most common SI Metric values.

**TABLE 4 - ANALOG INPUT RANGES (LOW PRESSURE CHILLERS)**

MEASUREMENT	MULTIPLY ENGLISH UNIT	BY FACTOR	TO OBTAIN METRIC UNIT
Capacity	Tons Refrigerant Effect (ton)	3.516	Kilowatts (kW)
Power	Horsepower	0.7457	Kilowatts (kW)
Flow Rate	Gallons / Minute (gpm)	0.0631	Liters / Second (l/s)
Length	Feet (ft)	304.8	Meters (m)
	Inches (in)	25.4	Millimeters (mm)
Weight	Pounds (lbs)	0.4538	Kilograms (kg)
Velocity	Feet / Second (fps)	0.3048	Meters / Second (m/s)
Pressure Drop	Feet of Water (ft)	2.989	Kilopascals (kPa)
	Pounds / Square Inch (psi)	6.895	Kilopascals (kPa)

### TEMPERATURE

To convert degrees Fahrenheit (°F) to degrees Celsius (°C), subtract 32° and multiply by 5/9 or 0.5556.

$$\text{Ex: } (45.0^{\circ}\text{F} - 32^{\circ}) \cdot 0.5556 = 27.2^{\circ}\text{C}$$

To convert a temperature range (i.e., a range of 10°F) from Fahrenheit to Celsius, multiply by 5/9 or 0.5556.

$$\text{Ex: } 10.0^{\circ}\text{F range} \cdot 0.5556 = 5.6^{\circ}\text{C range}$$



**BY JOHNSON CONTROLS**

P.O. Box 1592, York, Pennsylvania USA 17405-1592  
Copyright © by Johnson Controls 2010  
Form 160.00-M8 (810)  
New Release

Tele. 800-861-1001  
[www.york.com](http://www.york.com)

Subject to change without notice. Printed in USA  
ALL RIGHTS RESERVED