



**TWIN-TURBINE CENTRIFUGAL  
COMPRESSOR  
MODEL TT-300**



**SERVICE MONITOR USER MANUAL**

# Proprietary Notice

---

This publication contains information proprietary and confidential to Danfoss Turbocor Compressors Inc. Any reproduction, disclosure or unauthorized use of this publication is expressly prohibited without written approval from Danfoss Turbocor.

Danfoss Turbocor reserves the right to make changes without notice in product or component design as warranted by evolution in user needs or advancements in engineering or manufacturing technology.

Danfoss Turbocor has exercised its best efforts to ensure that the information contained in this manual is correct. However, no warranty of reliability or accuracy is given with respect to the information and Danfoss Turbocor shall not be responsible or liable for the correctness or suitability of the information or for any error or omission. If you encounter any difficulty in using this manual, please forward your query to Danfoss Turbocor or its authorized sales agent.

All brand names and product names used in this manual are trademarks, registered trademarks, or trade names of their respective holders.

**For product support issues, corrections, or enquiries, contact:**

**Product Support**  
**[product.support@turbocor.com](mailto:product.support@turbocor.com)**

**Danfoss Turbocor Compressors Inc.**  
**1850 Trans-Canada**  
**Dorval, Quebec**  
**Canada H9P 2N4**  
**Tel. (514) 421-0523**  
**Tel. (888) 440-0523**  
**Fax (514) 421-6490**  
**[www.turbocor.com](http://www.turbocor.com)**

# Contents

---

Introduction	1
System Requirements	2
Getting Started	3
Cable Connection	3
RS232 Connection	3
Modbus Connection	3
Monitor Program Installation	5
Starting the Monitor Program	5
User Interface	5
Monitor Program Toolbar	5
Entering User Input	6
Serial Port Connection	6
Compressor Configuration	7
Using the Setup Wizard	7
Start-up Settings	8
Electronics Valve Control	9
Analog Output Setup	11
Modbus Communications	12
Downloading and Saving Configuration Data	12
Using a Saved Configuration File	13
Controlling User Access	14
Starting and Stopping the Compressor	15
Analog Input	15
How to Start the Compressor	15
How to Stop the Compressor	15
Modbus Network	15
How to Start the Compressor	15
How to Stop the Compressor	16
Chiller Control	16
How to Start the Compressor	16
How to Stop the Compressor	16
Monitor Program Data and Controls	18
Main System	18
Bearing Calibration	20
Bearing Calibration Procedure	22
Calibration Data Interpretation	23
“Gain” Interpretation	23
“Offset” Interpretation	23
Compressor Control	23
Compressor Control Modes	26
Calibration	26
Manual Control	26
Analog Input	27
Modbus Network	27
Chiller Control	27
Compressor Faults/Alarms	27

# Contents

---

Motor Monitoring	28
Motor Monitoring Overview	28
Motor Faults / Alarms	30
Magnetic Bearing Monitoring	31
Bearing Monitoring Overview	31
Bearing Faults	33
Electronic Valve Data / Tuning	33
Chiller Control	36
System Information	38
Compressor Info	39
EEPROM Log Resets	39
EEPROM Settings	39
Compressor Controller Settings	40
Compressor Controller Alarms	41
Compressor Controller Fault Limits	43
Compressor Stepper Motor Settings	44
Stepper Motor Valve Controls	45
Analog Output Controls	47
Compressor Controller Impeller Specific Settings	49
Compressor Controller (CC) Critical Fault Lock Outs	50
Refrigerant	51
Compressor Event Log	51
History Data	52
Trending	53
Graphs	53
Trending & Data Acquisition	56
Compressor Map	57
Fault Captures	59
Data Capture	60
Appendix A: Determination of Actual Power Setting	65

# 1 Introduction

The Turbocor Service Monitor program is a rich, user-friendly, graphical user interface designed to control the Turbocor compressor and to provide status information about the compressor. Furthermore, it can be used as a tool for troubleshooting purposes.

This manual describes the functions provided by the Turbocor Service Monitor program.



## 2 System Requirements

The monitor program must be installed on a PC that meets the minimum requirements specified in Table 1. For optimum performance, a 533 MHz Pentium or higher CPU with 128 MB RAM running Windows 2000 (SP4) or XP is recommended.

The monitor program was developed for the .NET Framework and requires the .NET Framework to be installed on the PC where the program runs. Microsoft provides a re-distributable installer, Dotnetfx.exe, that

contains the common language runtime and .NET Framework components that are necessary to run the monitor program. Before installing the monitor program, the .NET framework 1.1 re-distributable must be installed. This can be downloaded from the Microsoft website.

The latest Windows service packs and security updates should also be installed on the PC.

**Table 1: Minimum Requirements**

<b>Processor</b>	533-MHz Intel Pentium-class processor
<b>Operating System</b>	<p>The .NET Framework 1.1 Re-distributable is supported on the following platforms:</p> <ul style="list-style-type: none"> <li>• Microsoft Windows® Server 2003 (.NET Framework 1.1 is installed as part of the operating system)</li> <li>• Windows XP Professional</li> <li>• Windows XP Home Edition</li> <li>• Windows 2000</li> <li>• Windows Millennium Edition (Windows Me)</li> <li>• Windows 98</li> <li>• Microsoft Windows NT® 4.0 Service Pack 6a</li> </ul> <p>The .NET Framework 1.1 Re-distributable cannot be installed on 64-bit computers; Windows NT 4.0 Terminal Server is not supported</p>
<b>Memory</b>	128 MB of RAM, 256 MB recommended
<b>Hard Disk</b>	110 MB of hard disk space required, 40 MB additional hard disk space required for installation (150 MB total)
<b>Display</b>	800 x 600 or higher-resolution display with 256 colors
<b>Input Device</b>	Microsoft mouse or compatible pointing device
<b>Other</b>	<p>Install the latest Windows service packs and critical updates from the Windows Update site.</p> <p>Installation of the .NET Framework 1.1 is split into two parts: the core and language packs. The core contains everything you need to run .NET Framework applications; all dialog boxes and error messages will be in English. If you want dialog boxes and error messages in another language, you must also install the corresponding language pack. For more information, see the .NET Framework Downloads page.</p>

## 3 Getting Started

### 3.1 Cable Connection

The monitoring program communicates with the compressor via the Modbus\* protocol using either the RS232 or RS485 connection at the Compressor Interface module. RS485 communication requires an RS485/RS232 adapter (user-supplied). RS232 communication is recommended for cable lengths not exceeding 15 meters (50 feet) between the PC and compressor. For cables that run up to 100 meters (328 feet), use the RS485 communication line. Always use shielded, twisted-pair cable for data communications

\*The Modbus protocol was originally developed to exchange information between products on the factory floor. This protocol has become a de facto standard for exchanging data and control between PLC systems. Modbus is a registered trademark of Modicon Corp.

#### 3.1.1 RS232 Connection

1. Connect one end of the RS232 cable (user-supplied) to the DB9 connector on the Compressor Interface module; see Figure 1.
2. Connect the other end of the cable to an available COM port on the PC.
3. Confirm that jumpers JP2 and JP7 are in proper positions before starting.

JP2 is the Modbus termination jumper. Install the jumper if the Modbus connection is at the end of a cable run.

Remove JP7 to enable RS-232 communication with the PC.

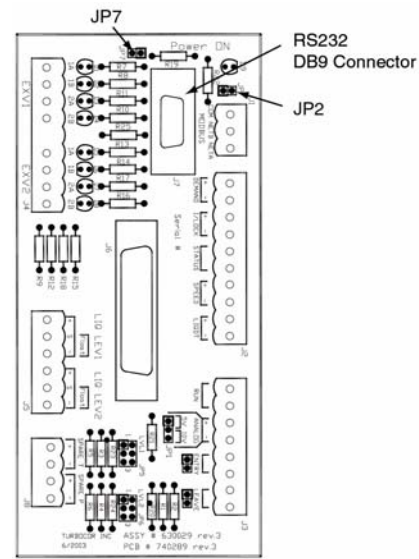

**Figure 1 RS232 Connector - Compressor Interface Module**

#### 3.1.2 Modbus Connection

1. Connect the RS485/RS232 adapter directly onto the PC COM port.

Connect the other side of the adapter to the Modbus. Figure 2 shows the PC and adapter connections to the Modbus for a single compressor application. Ensure that the termination jumper (JP2) on the Compressor Interface module is installed.

Figure 3 shows the PC and adapter connections to the Modbus for a multiple compressor application. In this case, set the termination jumper only on the Compressor Interface module that is connected at the end of the Modbus cable run.

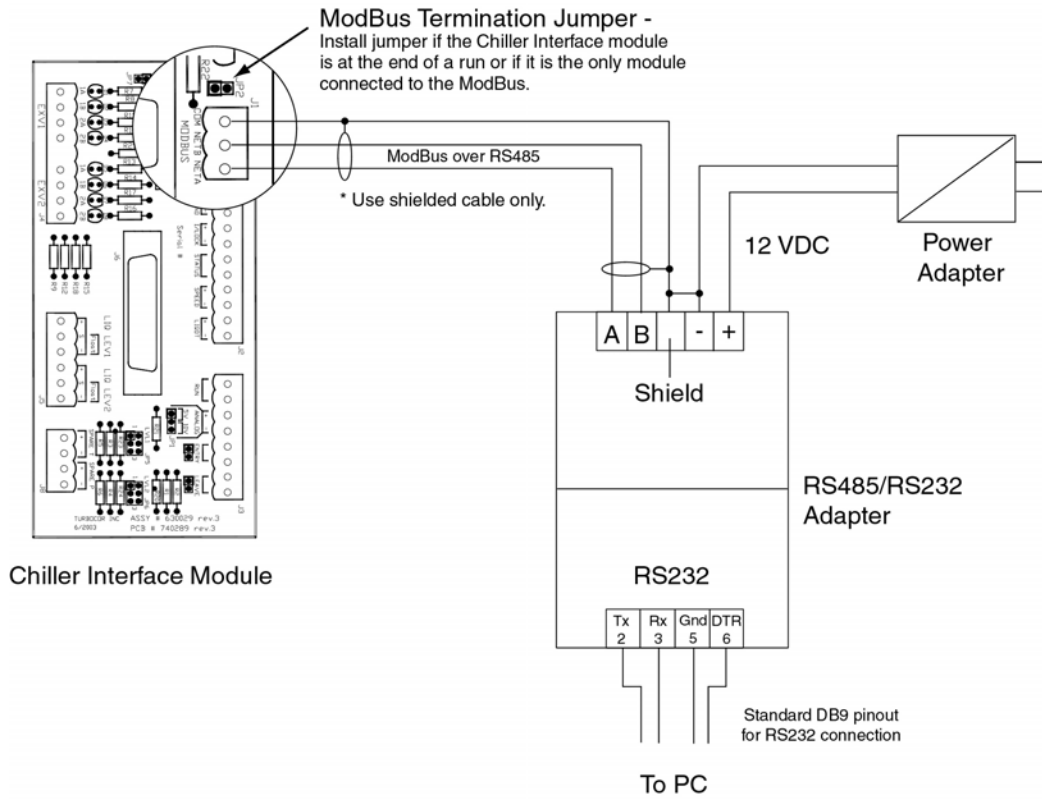

Figure 2 PC to Modbus Connection (single compressor with > 10 m cable length)

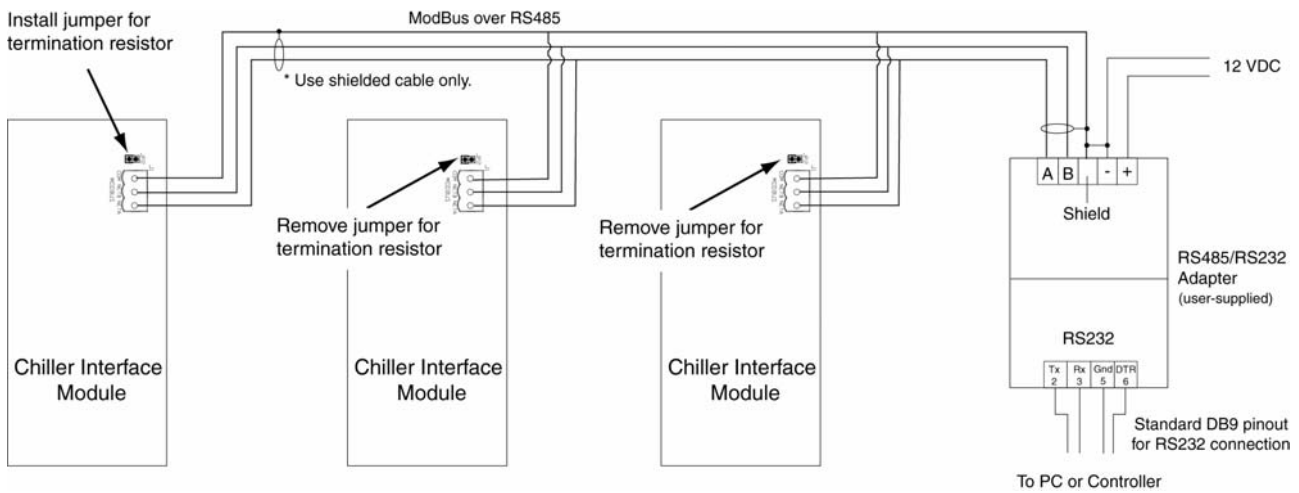

Figure 3 PC to Modbus Connection (multiple compressors with > 10 m cable length)

### 3.2 Monitor Program Installation

The monitor program is installed on the PC and communicates with the compressor using the ModBus protocol over a RS-232 or RS-485 serial link. Administrator privileges may be required to install and remove software on the PC.

**NOTE:**

If a previous version of the monitor program is already installed on the PC, it must be uninstalled before proceeding with the current installation. To uninstall the monitor program: from the “Start” menu, select “Settings” → “Control Panel”. Double-click “Add/Remove Programs”. From the list, select “Danfoss Turbocor Service Monitoring Tool” and then click the “Remove” button.

*Installation Procedure:*

1. Insert the monitor program CD into the drive.
2. In Windows Explorer, navigate to the Turbocor\_Service\_Tool\_Setup.msi file. Double-click the file to launch the setup wizard.
3. Follow the instructions provided by the wizard to complete the installation.
4. Click the Close button to exit the setup wizard.

### 3.3 Starting the Monitor Program

To start the monitor program: from the “Start” menu, select “Programs” → “Danfoss Turbocor Monitoring Tool”.

### 3.4 User Interface





#### 3.4.1 Monitor Program Toolbar

The toolbar (located under the menu bar) provides the user with easy access to the monitoring windows. Table 2 provides details for each icon on the toolbar.









**NOTE:**

Up to three windows can be displayed at one time. If three windows are already open, one must be closed before another window can be opened.

**Table 2 Monitor Program Toolbar Icons**

Icon	Name	Description
	Serial Port Connection	Clicking on the “Serial Port Connection” icon opens the “Serial Port Connection” window. Refer to section 3.5 "Serial Port Connection" on page 6.
	Compressor Controller Parameters	Clicking on the “Compressor Controller Parameters” icon opens the “Compressor Controller” window. Refer to section 6.3 "Compressor Control" on page 23.
	Motor Monitor	Clicking on the “Motor Monitor” icon opens the “Variable Speed Permanent Magnet Motor Monitoring” window. Refer to section 6.4 "Motor Monitoring" on page 28.
	Magnetic Bearings	Clicking on the “Magnetic Bearings” icon opens the “Magnetic Bearing Monitoring” window. Refer to section 6.5 "Magnetic Bearing Monitoring" on page 31.

**Table 2 Monitor Program Toolbar Icons (Continued)**

Icon	Name	Description
	Expansion Valves	Clicking on the “Expansion Valves” icon opens the “Electronic Valve / Data Tuning” window. Refer to section 6.6 "Electronic Valve Data / Tuning" on page 33.
	Event Log	Clicking on the “Event Log” icon opens the “Compressor Event Log” window. Refer to section 6.10 "Compressor Event Log" on page 51.
	EEPROM Settings	Clicking on the “EEPROM Settings” icon opens the “EEPROM Settings” window. Refer to section 6.9 "EEPROM Settings" on page 39.
	Load Profile Graphs	Clicking on the “Load Profile Graphs” icon opens the “Compressor History Data” window. Refer to section 6.11 "History Data" on page 52.
	Fault Captures	Clicking on the “Fault Captures” icon opens the “Fault Captures” window. Refer to section 6.14 "Fault Captures" on page 59.
	Trending	Clicking on down arrow next to the “Trending” icon, and selecting “Charts 1” opens the trending “Graphs” window; selecting on “Charts 2” opens the “Trending and Data Acquisition” window. Refer to section 6.12 "Trending" on page 53.
	Chiller Control	Clicking on the “Chiller Control” icon opens the “Chiller Control” window. Refer to section 6.7 "Chiller Control" on page 36.
	Compressor Envelope	Clicking on the “Compressor Envelope” icon opens the “Compressor Map” window. Refer to section 6.13 "Compressor Map" on page 57.

### 3.4.2 Entering User Input

When user input is required for the monitor program fields, perform the following sequence:

1. Double-click the variable field. (This activates the field for user input.)
2. Scroll or type in the new setting.
3. Press Enter. It is important to press Enter as this causes the user input to be validated.

### 3.5 Serial Port Connection

The Serial Port Connection window contains fields that must be filled in order to enable communication between the monitor program and the compressor; refer to Figure 4. The comm settings of the compressor must be known in order for the monitor program to communicate with the compressor.

To access the “Serial Port Connection” window, select “Window”→ “Connection” from the menu bar, or click on the “Serial Port Connection” icon located below the menu bar.

The following paragraphs describe the dialog box fields.

**Comm Port** - Serial communication port that the computer will use to connect to the compressor. Enter the COM port number such as COM1 or COM2, etc.

**Baud Rate** -19,200 or 38,400 baud (38,400: default)

**Stop Bits** - 1 or 2. (1: default)

**Slave Address** - 1-63. (1: default)

**Access Code** - The access code controls access to all adjustable parameters. The default user access level on power up is read only. Enter the code that corresponds to the access level you require. Contact Turbocor Product Support to obtain the required access code.

1. Once the serial port connection data has been set, click the Connect button. At this point, connection status, compressor details, and user access level appear in the right-hand pane of the dialog box.
2. If necessary, change the access level. Enter the access code in the “Access Code” parameter box, then click “Change Access Level”. Confirm that the correct access level has been set on the right-hand pane of the dialog box.

**NOTE:**

The access level connection *cannot* be changed prior to a establishing connection.

Entering the wrong access code more than 3 times will lock out all communications until a cycle of the power is performed.

3. Click the “OK to start monitoring” button.



**Figure 4 Serial Port Connection Dialog Box**

## 4 Compressor Configuration

### 4.1 Using the Setup Wizard

The monitor program features a commissioning setup wizard to guide the user through the complete compressor configuration process.

1. To launch the commissioning setup wizard, select “System Commissioning” from the “Advanced” menu item. The introduction screen for the commissioning setup wizard appears; refer to Figure 5. Click Next.

(To bypass the setup wizard and use a saved configuration file to setup the compressor, check the checkbox and click Next. Continue with 4.2 "Using a Saved Configuration File" on page 13.)

2. Select the appropriate units of measurement (metric or imperial). Refer to Figure 6.
3. Select the appropriate compressor control method. There are three modes available:

- Analog Input: compressor loading controlled using an analog demand signal of 0-10 VDC from an

external controller. The variable demand signal corresponds to the range of 0-100% maximum power available.

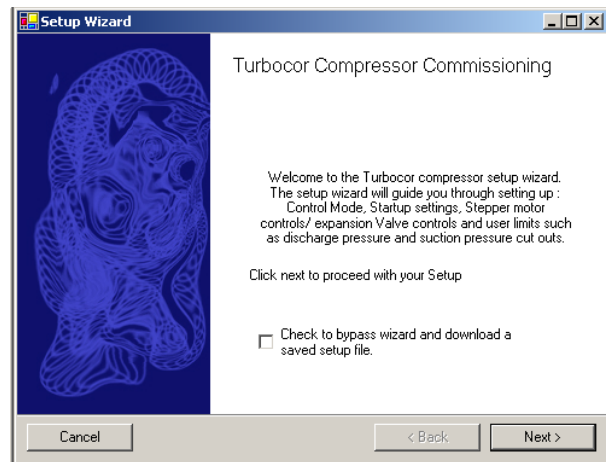

**Figure 5 Commissioning Set-up Wizard**

## Compressor Configuration

- Modbus Network: the compressor receives a demand from an external computer, PLC, or building management system using the Modbus protocol on a RS-232 or RS-485 communication link.
- Chiller Control: fully automatic; controls the chilled water temperature using a temperature sensor connected directly to the Compressor Interface module. This mode can also be used to control evaporating temperature which is derived from the suction pressure measurement

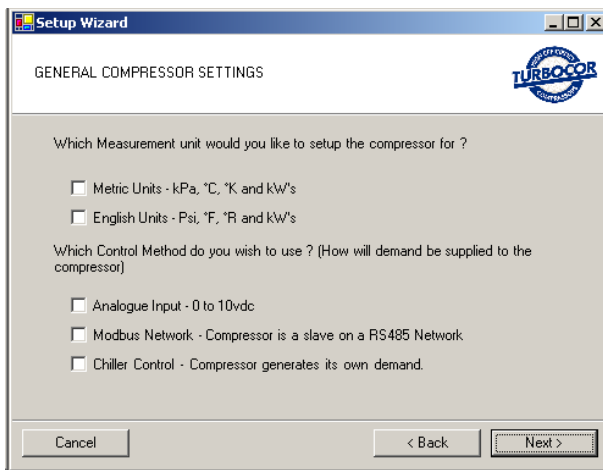

Figure 6 General Compressor Settings

### NOTE:

If the compressor is linked to an external controller, changes made to the compressor demand via the monitor program can conflict with controller-issued commands. This situation can lead to unexpected results. Before testing the demand input, isolate the compressor from the controller.

4. Click the Next button.

Steps 5 through 8 apply to the Chiller Control mode only.

5. Select the type of sensor that will control the chiller. If selecting Entering or Leaving Chiller Air/Water Temperature, connect an NTC temperature sensor (as specified in the compressor Application manual) to either the Entering- or Leaving Chilled Water temperature input on the Compressor Interface module.

6. Set the Chiller Control Set Point to the desired value.
7. Set the Proportional and Integral Gain values to obtain stable control (the Proportional and Integral Gain values will vary depending on the application).

### NOTE:

The Integral part of the internal chiller controller is switched off until the compressor reaches a speed of 18,500 RPM. Stopping the compressor and restarting also resets the Integral part to 0.

8. Click in the Chiller Enable checkbox if you would like to have the compressor start automatically. It is advised, however, to open the interlock contact (located on the Compressor Interface module) to prevent the compressor from starting before the commissioning sequence is complete.

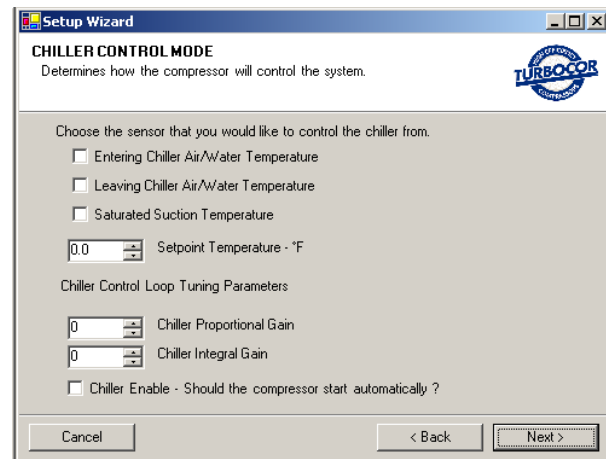
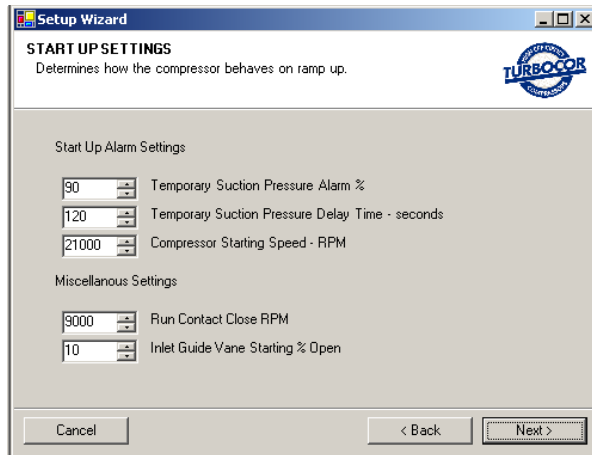

Figure 7 Chiller Control Commissioning

### 4.1.1 Start-up Settings

(Refer to Figure 8)

1. Enter the Temporary Suction Pressure Alarm %. The limit is set up as a % of the current suction pressure limit, e.g., if a suction pressure trip of 270 kPa was set and the temporary suction pressure alarm was set to 50%, the temporary suction pressure trip limit would be 135 kPa. This temporary alarm is only active while the Suction Pressure Delay timer is counting down.



**Figure 8 Start-up Settings**

2. Enter the Temporary Suction Pressure Delay Time. This parameter represents time in seconds that the temporary suction pressure alarm / fault limit should be enabled. The timer starts to count down once the shaft starts to rotate.
3. Enter the Compressor Starting Speed. If the estimated surge speed is greater than the starting speed setting, the compressor will ramp up to the surge speed. If the starting speed setting is greater than the estimated surge speed, the compressor will ramp up to the starting speed. In both cases, the compressor speed will increase at the full ramp rate. The minimum starting speed should be 18,500, although 21,000 is recommended.
4. Enter the Run Contact Close RPM. The compressor contains a NO relay contact that closes while the compressor is running. The speed at which the contact closes is determined by the Run Contact Close RPM.
5. Enter the Inlet Guide Vane Starting % Open. Typically, the vanes will be set to the closed or almost closed position at start-up. This is to minimize the possibility of liquid flood back and to reduce the compressor's start-up current draw.
6. Click Next to continue.

## 4.1.2 Electronics Valve Control

(Refer to Figure 9)

This section explains how to set up the expansion valves for various applications. Both valves can be operated independently or in parallel.

For Expansion Valve #1:

1. Enter the number of steps to drive the valve from fully closed to fully open. Expansion valves with different numbers of steps can be used.

### **WARNING**

If the incorrect number of steps is selected, the valves may not have enough travel to allow the required amount of mass flow or the valve may not be able to throttle down to the required amount of mass flow. This situation could cause liquid flood back and damage to the compressor.

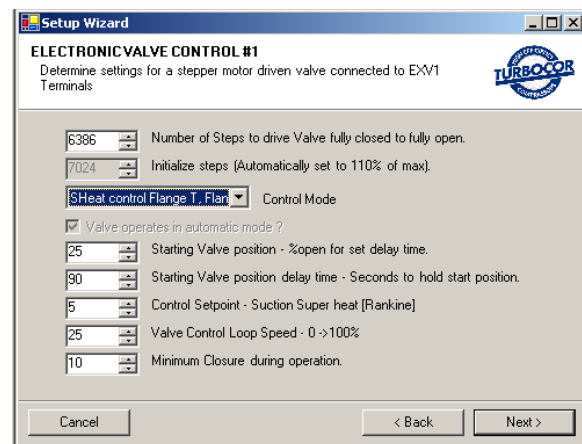

**Figure 9 Electronics Valve Control Setup**

2. Select the control mode for the expansion valve. Available options are: superheat, liquid level, or load balance. See Table 3 for a description of the modes.
3. Enter the Starting Valve Position. If desired, at compressor start-up, the valves can be set to open to a pre-start value for a given time. This value represents the percentage of maximum steps sent to the motor upon start-up of the compressor. The stepper motor will hold at this position until the stepper start delay timer has expired.
4. Enter the Valve Starting Position Delay Time. The delay is the amount of time (from compressor start-up)

## Compressor Configuration

---

- to hold the number of steps sent to the motor as determined by the Starting Valve Position %. Value is in seconds and starts to count down when the drive is enabled.
5. Enter the Control Setpoint, i.e., suction superheat or liquid level. (Not applicable to load balance control mode.)
  6. Enter the Valve Control Loop Speed. This value represents the reaction time of the control loop to a process error and replaces the PID controller gains (proportional, integral, and derivative).
  7. Enter the Minimum Closure During Operation. This is the minimum close position for the valve while the compressor is spinning.
  8. Click Next to continue. Repeat steps 1 through 7 for electronic expansion valve # 2.

**Table 3 Expansion Valve Control Modes**

Control Mode	Description
Superheat	<p>The calculation of superheat can be based on the temperature and pressure measurements from one of the following sources:</p> <ul style="list-style-type: none"> <li>• Superheat control using the compressor flange temperature and pressure (this mode is not recommended as the temperature at the compressor flange is influenced by external factors).</li> <li>• Superheat control using the compressor flange pressure and a 10K thermistor that is connected to the terminals labeled “ENTRY” on the Compressor Interface module.</li> <li>• Superheat control using the compressor flange pressure and a 10K thermistor that is connected to the terminals labeled “LIQT” on the Compressor Interface module.</li> <li>• Superheat control using an external temperature and pressure sensor connected to the terminals on the IO pcb labeled “SPARE T” &amp; “SPARE P”.</li> </ul>
Liquid Level	<p>Liquid level can be measured from one of the following sources:</p> <ul style="list-style-type: none"> <li>• Liquid Level 1 control using a level sensor connected to the terminals on the Compressor Interface module labeled “LIQ LEV1”.</li> <li>• Liquid Level 2 control using a level sensor connected to the terminals on the Compressor Interface module labeled “LIQ LEV2”.</li> </ul> <p>For liquid level sensing, two types of level sensors can be used: a level sensor with a supply of 15VDC and an output of 0-5VDC or a resistive-type level sensor, 0-90 Ohm. Refer to vendor documentation for wiring these types of sensors to the Compressor Interface module.</p>
Load Balance	<p>The Load Balance control mode uses the compressor’s own internal control algorithm to determine the best mix of speed control, inlet guide vane opening and load balance valve opening. Use this mode only if a load balancing valve is installed in the system. Since the load balancing valve is connected to the compressor’s capacity control algorithm, selecting this mode without a valve installed will add a delay to the loading/unloading process, i.e., the compressor will try to open and close the valve for 2 minutes rather than close the vane or change the speed.</p>

### 4.1.3 Analog Output Setup

The compressor features a universal analog output for load balancing valve, IGV position, discharge pressure, etc. The operating range can be set to 0-5V or 0-10V via jumpers on the Compressor Interface module.

Interface module is connected to a 3-way valve that channels chilled water to a cooling coil. A temperature sensor at the cooling coil is connected to the Leave terminals of the Compressor Interface module. The analog output controls the amount of chilled water entering the cooling coil based on the air temperature setpoint.

Figure 10 shows a typical application for the analog output. In this example, the analog output from the Compressor

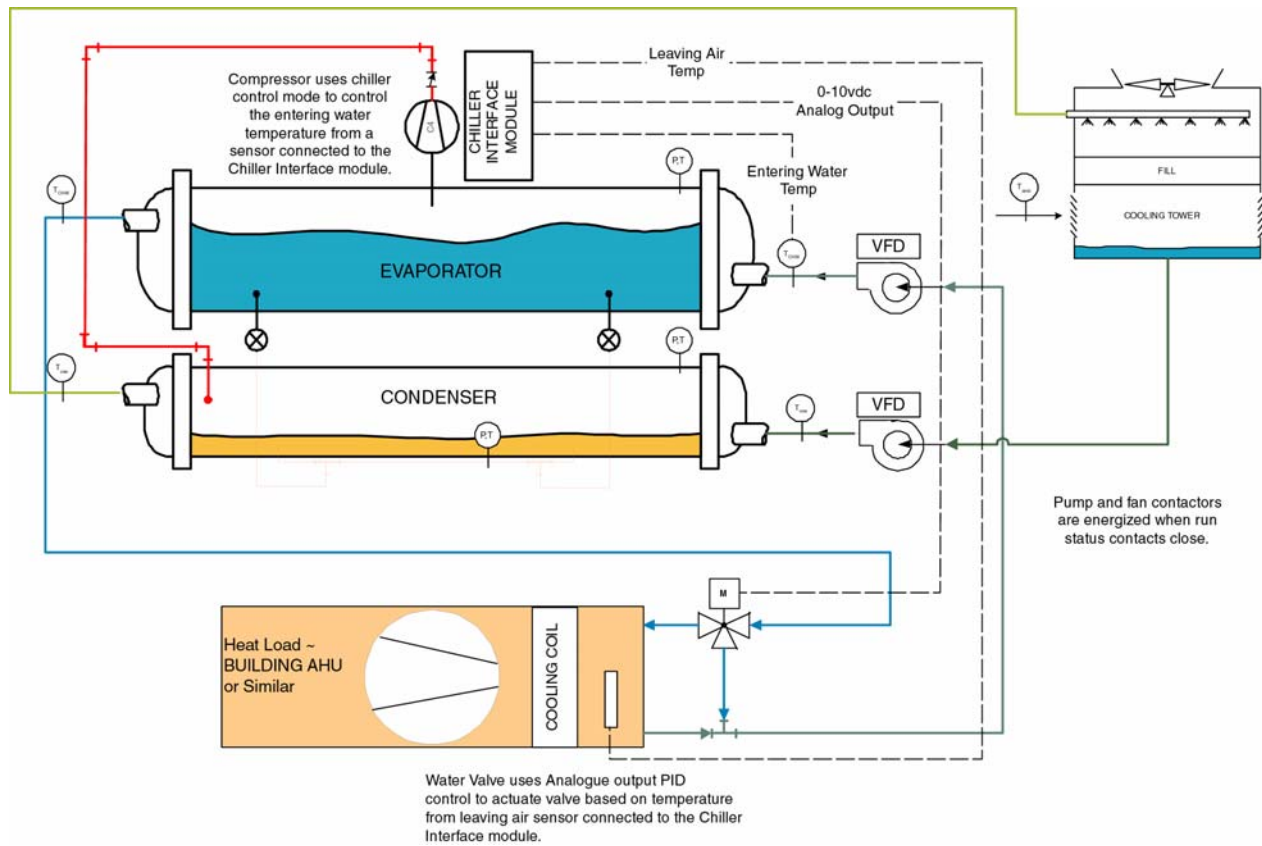

Figure 10 Analog Output Application Example

Configure the analog output as follows (Refer to Figure 11):

1. Select the control mode for the analog output. The selection determines which control variable will be the source for the 0-10vdc output (at the ANALOG output terminals on the Compressor Interface module). The options are:

- Load Balance
- HP
- IGV

- Auto
- Superheat - Flange TP
- Superheat - FlangeP, EWT
- Superheat - FlangeP, LIQT
- Suction Pressure.
- Leaving Temp
- Entering Temp
- Liquid Temp

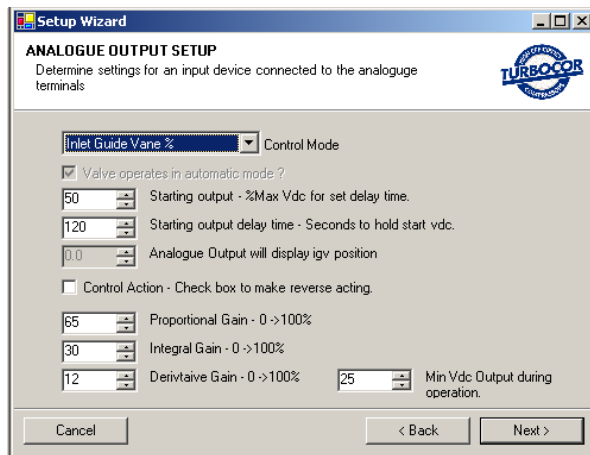

**Figure 11 Analog Output Setup**

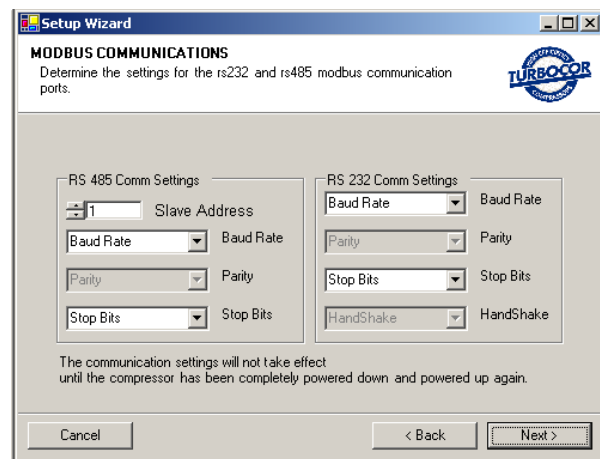

**Figure 12 Modbus Communications Setup**

2. Enter the Starting Output. This value equals the percentage of maximum voltage sent to the terminals of the Compressor Interface module on compressor start-up. The analog output will hold at this position until the start delay timer has expired.
3. Enter Starting Output Delay Time. This value is the amount of time from compressor start-up to hold the voltage at the start-up %. Value is in seconds and starts to count down when the drive is enabled.
4. Check the Control Action checkbox for reverse acting. Leaving the checkbox unchecked will enable direct acting.
5. Enter the Proportional, Integral, and Derivative gains to provide stable control.
6. Enter the minimum analog output (in DC volts) during operation, if required. This parameter can be used, for example, to maintain a minimum valve open position during operation.

## 4.1.4 Modbus Communications

(Refer to Figure 12)

Set up the RS-485 and RS-232 ports, as required, on the Compressor Interface module to enable communication with an external PLC, computer or building management system.

## 4.1.5 Downloading and Saving Configuration Data

At the end of the commissioning sequence, you have the choice of either downloading the configuration data to the compressor or saving it to a file for later use.

To save the data to a configuration file, click the Save to Configuration File button. In the Save As dialog box, name the file and save it in a designated location.

### NOTE:

If modifications are made to the configuration data after the commissioning is complete, the new values must be recorded in a new commissioning session if the data is to be saved to a file.

### WARNING

Never attempt a download while the compressor is running as it can lead to a loss of compressor control. Open interlock contacts on the Compressor Interface module before downloading configuration data.

For immediate downloading of the configuration data to the compressor, click the Download to Compressor button. To enable the new configuration data, perform the following steps:

1. Turn OFF power to the compressor. Wait at least 5 minutes, then check that the LEDs on the Backplane are OFF.
2. Turn ON power to the compressor.

**IMPORTANT:**

Record the comm settings before you close the monitor program since they will be necessary to communicate with the compressor when you restart the monitor program.

3. Close and then restart the Monitor program.

## 4.2 Using a Saved Configuration File

Follow the steps outlined here if you have bypassed the commissioning wizard in order to download a configuration file to the compressor.

configuration file has been successfully downloaded to the compressor.

**WARNING**

Never attempt a download while the compressor is running as it can lead to a loss of compressor control. Open interlock contacts on the Compressor Interface module before downloading configuration data.

1. Click the “Load configuration from file” button; refer to Figure 13.
2. In the Open File dialog box, browse to the location of the .ttc file.
3. Click Open.
4. On the Download Settings form, click “Download to compressor” button.
5. When the message “Done. Cycle power before running the compressor” appears, turn OFF power to the compressor; refer to Figure 14. Wait at least 5 minutes, then check that the LEDs on the Backplane are OFF.
6. Close the Monitor program.
7. Turn ON power to the compressor.
8. Restart the Monitor program.
9. Once reconnected, the text in the right-hand pane of the Serial Port Connection dialog box appears in red. When the text turns black, it indicates that the new

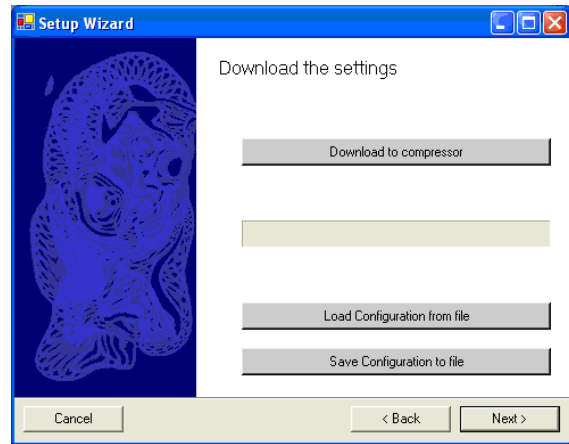

**Figure 13 Download Settings Screen**

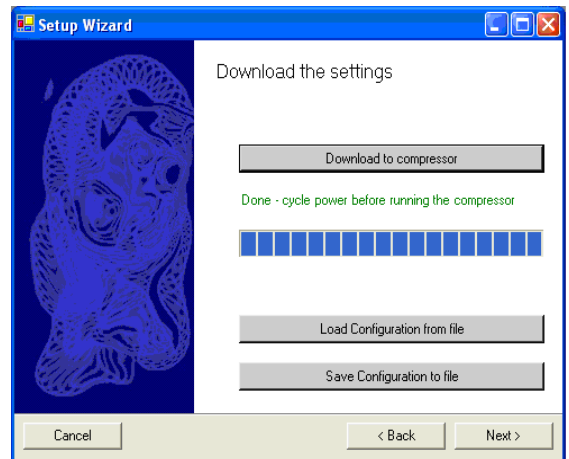

**Figure 14 Download Settings Screen (After Download)**

### 4.3 Controlling User Access

The access code system allows OEM customers to set their own unique pass codes thereby restricting access to company authorized personnel.

These access codes control access to all adjustable parameters via the Modbus communications layer. The access levels are:

- Read only ~ User may only view values across the Modbus layer.
- Low Level ~ User may only alter basic settings such as leaving chilled water temp, display units, chiller enable/disable, etc.
- Mid Level ~ User may alter all settings that are required for commissioning a compressor in the field. Values alterable, for example, are control mode, valve control settings, run status contact energize RPM, reset load profile data, and retrieve and save fault data.
- High level ~ User may alter all settings. This level of access is reserved for users that configure motor/compressor and bearing control only.

Upon power-up of the compressor, the access codes are calculated and stored in RAM memory. The default user access level on power up is read only.

To change the access code, select “Access Codes” from the “Advanced” menu item; refer to Figure 15.

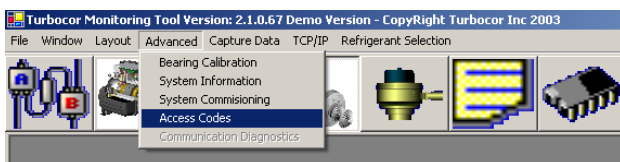

**Figure 15 Navigating to the Access Code Change Form**

The Access Code Change form appears. To change the access code for a specific user level:

1. Select the appropriate radio button.
2. Enter the current access code followed by the new access code for the selected user level (if you enter the incorrect access code nothing will be changed).
3. Re-enter the new access code in the Confirm Access Code field.
4. Click the Change Access Code button.

**NOTE:**

The new access code does not take effect until the compressor has been restarted.

**Figure 16 Access Code Change Form**

## 5 Starting and Stopping the Compressor

The following sections describes how to start and stop the compressor. Refer to the section corresponding to the

control method selected during configuration of the compressor.

### 5.1 Analog Input

The Analog Input mode controls the compressor loading using an analog demand signal of 0-10 VDC from an external controller. The variable demand signal corresponds to the range of 0-100% maximum power available.

**NOTE:**

The Compressor Interface interlock switch must be closed and no errors present for the compressor to start up and run.

2. Connect a 0-10VDC demand signal to the Compressor Interface module.
3. Apply a signal between 2 and 10VDC to the ‘Demand’ input. (2VDC = min kW/min speed, 10VDC = max kW according to model capacity.)

#### 5.1.1 How to Start the Compressor

1. Make sure the contact to the ‘Interlock’ input on the Compressor Interface module is closed.

---

 **WARNING**

Ensure that power to the compressor is OFF before connecting wiring to the Compressor Interface module.

---

#### 5.1.2 How to Stop the Compressor

Decrease the demand signal to 0VDC **or** open the contact connected to the ‘Interlock’ input on the Compressor Interface module. The compressor will ramp down to 0 RPM and de-levitate.

### 5.2 Modbus Network

In Modbus Network mode, the compressor receives a demand from an external computer, PLC, or building management system using the Modbus protocol on a RS232 or RS485 communication link.

**NOTE:**

The Compressor Interface interlock switch must be closed and no errors present for the compressor to start up and run.

#### 5.2.1 How to Start the Compressor

Open the “Compressor Controller” window. Click on the “Compressor Controller Parameters” icon located below the menu bar.

On the Compressor Control Data form, click in the Loading Demand field and enter a value representing a percentage of maximum power available. (The maximum power available is dependent on the compressor model.) The compressor will levitate and spin up. Refer to Figure 17

The screenshot shows a software window titled "Comp Control Te=4.8 Tc=39.1 SH=-2.4". It features several dropdown menus for "No Faults", "No Alarms", and "Chiller Control". A list of parameters is displayed with their current values: Loading Demand (79.1%), Inlet Guide Vane (110%), Suction Pressure (248 kPag), Common Discharge Pressure (-101.3 kPag), Discharge Pressure (888.7 kPag), Suction Temperature (2.4 °C), SCR Temperature (29.2 °C), Discharge Temperature (47 °C), Cavity Temperature (47 °C), Controller PCB Temperature (44.5 °C), Back-Plane Temperature (33 °C), Stepper PCB Temperature (42 °C), Entering Air/Water Temperature (15 °C), Leaving Air/Water Temperature (6.8 °C), Liquid Temperature (23.6 °C), InterLock Contact (Closed), External Pressure (-101.3 kPag), External Temperature (-61.2 °C), Total Compression Ratio (2.836), Estimated Minimum Speed (30208 RPM), Maximum Speed (34432 RPM), and Suction Pressure Delay Timer (30). A button at the bottom indicates "Compressor Display Units = Metric". A status box at the bottom shows "Normal Operation,".

Figure 17 Compressor Control Form

## 5.3 Chiller Control

The Chiller Control mode is fully automatic and controls the chilled water temperature using a temperature sensor connected directly to the Compressor Interface module. This mode can also be used to control evaporating temperature which is derived from the suction pressure measurement

### NOTE:

The Compressor Interface interlock switch must be closed and no errors present for the compressor to start up and run.

## 5.2.2 How to Stop the Compressor

To stop the compressor, enter '0' in the Loading Demand field.

## 5.3.1 How to Start the Compressor

Open the "Chiller Control" window. Select "Window" → "Chiller Control" from the menu bar, or click on the "Chiller Control" icon located below the menu bar.

On the Chiller Control form, check the Chiller Enable Status box. The compressor will ramp up and adjust its speed to reach and maintain the setpoint. Refer to Figure 18.

## 5.3.2 How to Stop the Compressor

On the Chiller Control form, uncheck the Chiller Enable Status box. The compressor will ramp down to 0 RPM and de-levitate.

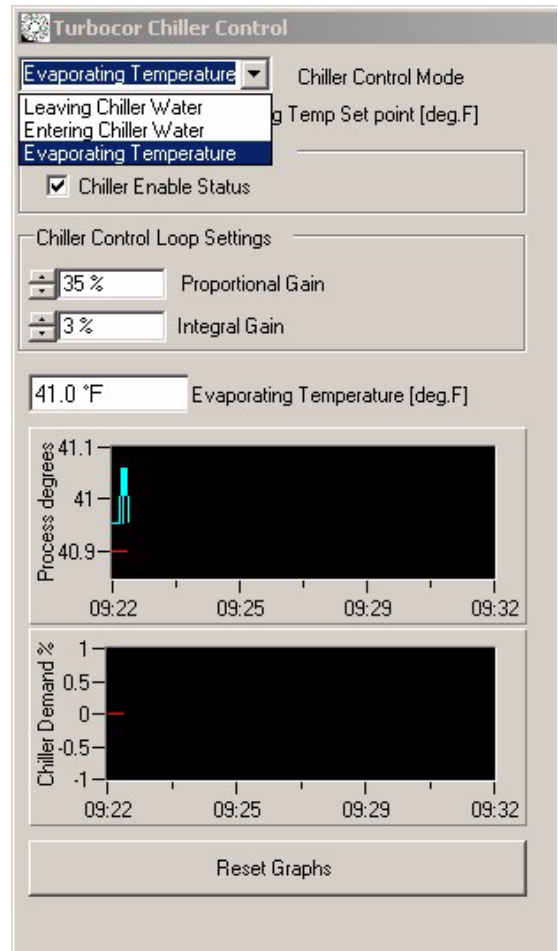

Figure 18 Chiller Control Form

# 6 Monitor Program Data and Controls

This section provides a detailed description of the forms and related data and controls that are accessible via the monitor program's user interface. The forms are organized as follows:

- main system
- bearing calibration
- compressor control
- motor monitoring
- magnetic bearing monitor
- electronic valve tuning
- chiller control
- system information
- EEPROM settings
- compressor event log
- history data
- trending
- compressor map
- fault captures
- data captures

## 6.1 Main System

The "General Data Page" allows the user to quickly view the following major compressor parameters:

- AC input power
- compressor demand
- shaft speed
- suction temperature/pressure
- discharge temperature/pressure
- IGV % open
- evaporating temperature
- condensing temperature
- power input
- shaft speed
- IGV % Open
- demand

To view the "General Data Page", select "Window" → "Main System" from the menu bar. Table 4 provides a description of the "General Data Page" parameters.

The "General Data Page" also plots the following parameters with respect to time:

The units used to display the temperature readings depend on the measurement unit set (Metric: °C; Imperial: °F). To verify or change the measurement unit, refer to section 6.3 "Compressor Control" on page 23. The time displayed corresponds to the PC system time, and is displayed in HH:MM format. To clear the graphs, click on the "Reset Graphs" button.

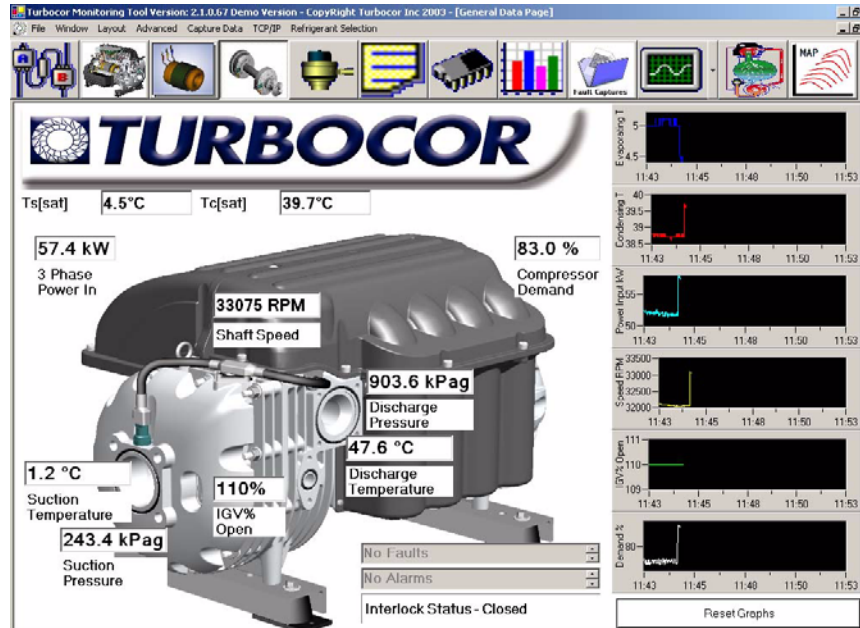

Figure 19 General Data Page

Table 4 General Data Page Parameters

Parameter	Description
Ts [sat]	Saturated suction temperature
Tc [sat]	Saturated discharge temperature
3 Phase Power In	3-phase AC input power (mains input)
Shaft Speed	Actual shaft speed in RPM
Compressor Demand	Requested motor power demand as a percentage of maximum motor power [kW].
Discharge Pressure	The actual discharge gauge pressure at the compressor flange as measured by the discharge pressure transducer.
Discharge Temperature	The actual discharge temperature at the compressor flange as measured by the discharge temperature/pressure transducer.
Suction Temperature	The actual suction temperature at the compressor flange as measured by the suction temperature/pressure transducer.
Suction Pressure	The actual suction pressure at the compressor flange as measured by the suction pressure transducer.
IGV % Open	% of Inlet guide vane opening, 0.0% means the vanes are at 90° to the pipe line (Fully closed). 110% means 10° over turned from fully open.
Fault Text Box	Displays the compressor's most recent active critical fault. Refer to 6.3.2 "Compressor Faults/Alarms" for fault details.
Alarm Text Box	Displays the compressor's most recent active alarm. Refer to 6.3.2 "Compressor Faults/Alarms" for alarm details.
Interlock Status	Displays the status of the interlock: either open or closed.

## 6.2 Bearing Calibration

The “Calibration Data” window allows the user to view and compare the data of the latest calibration performed with the latest stored calibration data, thus allowing the user to verify that the bearing calibration was performed successfully. It also allows the user to perform a manual bearing calibration.

To view the “Calibration Data” window: from the menu bar, select “Advanced”→ “Bearing Calibration” .

**NOTE:**

Bearing calibration is always automatically performed during compressor startup.

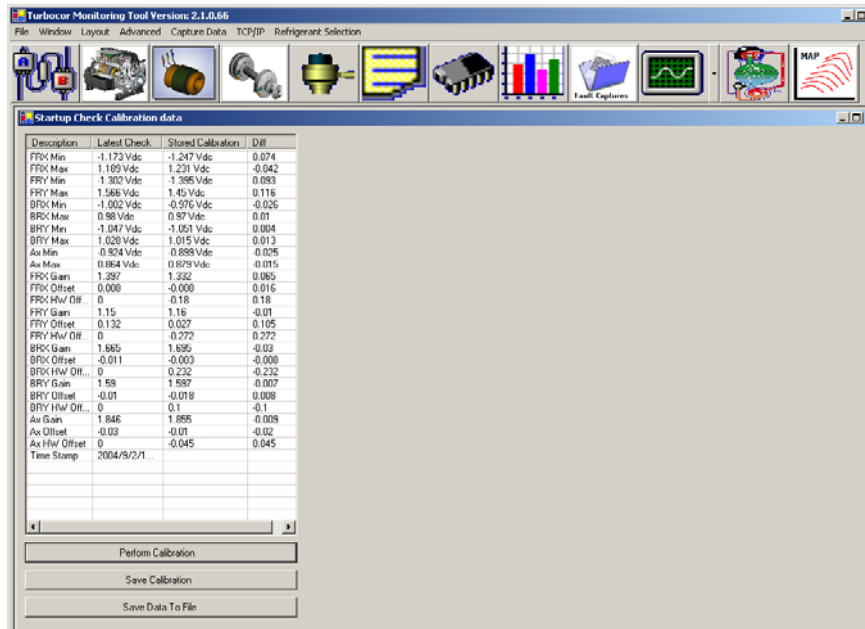

**Figure 20 Bearing Calibration Window**

The “Description” column lists the calibration data parameters. A more detailed description of the calibration data parameters is provided in Table 5.

The “Latest Check” column shows the calibration data of the latest calibration performed.

The “Stored Calibration” column shows the calibration data of the latest saved calibration data.

The “Diff” column shows the difference between the “Latest Check” value and the “Stored Calibration” value.

Clicking on the “Save Calibration” button stores the data from the “Latest Check” as the “Stored Calibration” data.

Clicking on the “Save Data To File” button saves the calibration data displayed on the “Calibration Data” screen to a .csv file, which may be viewed using a spreadsheet editor such as Microsoft® Excel.

Clicking on the “Perform Calibration” button, performs a manual bearing calibration.

**Table 5 Calibration Data Details**

Data Parameter	Description
FRX Min	Minimum DC voltage indicating minimum front radial x displacement.
FRX Max	Maximum DC voltage indicating maximum front radial x displacement.
FRY Min	Minimum DC voltage indicating minimum front radial y displacement.

**Table 5 Calibration Data Details**

<b>Data Parameter</b>	<b>Description</b>
FRY Max	Maximum DC voltage indicating maximum front radial y displacement.
BRX Min	Minimum DC voltage indicating minimum rear radial x displacement.
BRX Max	Maximum DC voltage indicating maximum rear radial x displacement.
BRY Min	Minimum DC voltage indicating minimum rear radial y displacement.
BRY Max	Maximum DC voltage indicating maximum rear radial y displacement.
Ax Min	Minimum DC voltage indicating minimum axial displacement.
Ax Max	Maximum DC voltage indicating maximum axial displacement.
FRX Gain	Gain Formula: Fixed Voltage / (FRX Min Voltage - FRX Max Voltage)
FRX Offset	Difference between the x-component of the front radial sensor center and the x-component of the front touchdown bearing center. Refer to Figure 22.
FRX HW Offset	Hardware offset.
FRY Gain	Gain Formula: Fixed Voltage / (FRY Min Voltage - FRY Max Voltage)
FRY Offset	Difference between the y-component of the front radial sensor center and the y-component of the front touchdown bearing center. Refer to Figure 22.
FRY HW Offset	Hardware offset.
BRX Gain	Gain Formula: Fixed Voltage / (BRX Min Voltage - BRX Max Voltage)
BRX Offset	Difference between the x-component of the rear radial sensor center and the x-component of the rear touchdown bearing center. Refer to Figure 22.
BRX HW Offset	Hardware offset.
BRY Gain	Gain Formula: Fixed Voltage / (BRY Min Voltage - BRY Max Voltage)
BRY Offset	Difference between the y-component of the rear radial sensor center and the y-component of the rear touchdown bearing center. Refer to Figure 22.
BRY HW Offset	Hardware offset.
Ax Gain	Gain Formula: Fixed Voltage / (Ax Min Voltage - Ax Max Voltage)
Ax Offset	Difference between the axial sensor zero and the touchdown axial center. Refer to Figure 23.
Ax HW Offset	Hardware offset.
Time Stamp	Date and time of calibration.

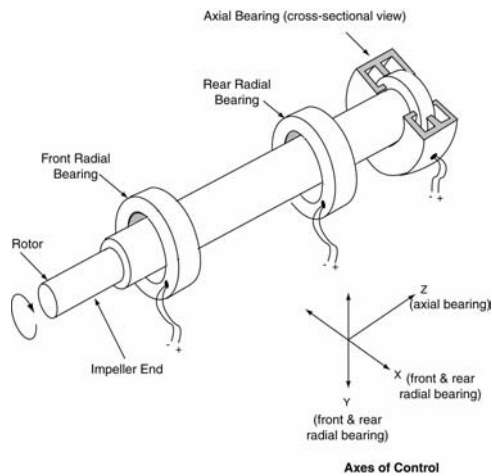

Figure 21 Magnetic Bearing Configuration

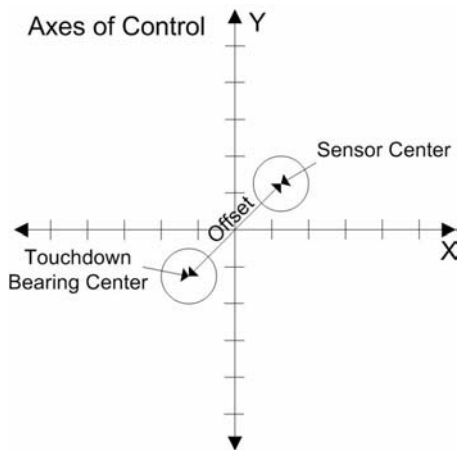

Figure 22 Front and Rear Bearing Offset

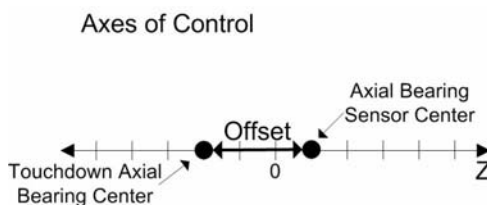

Figure 23 Axial Bearing Offset

### 6.2.1 Bearing Calibration Procedure

For the bearing calibration to be performed:

- The shaft must be de-levitated
  - The interlock connection on the Compressor Interface module must be open
1. Turn OFF the AC input power to the compressor and wait 3-5 minutes for the capacitors to discharge.
  2. Turn ON the AC input power to the compressor.
  3. Launch the monitor program. If the monitor program is already running, close it and open it again.
  4. Change the compressor control mode to “Calibration Mode”. Refer to 6.3 "Compressor Control" on page 23.

**NOTE:**

In Calibration mode, the compressor prepares itself for calibration. Any external demand will be blocked from the system, i.e., any external computer, PLC, building management system, or automatic control will *not* be able to write to the compressor.

5. From the menu bar, select “Advanced”→ “Bearing Calibration”. The “Startup Check Calibration Data” window appears, as shown in Figure 20.
6. Click on “Perform Calibration”. The message “Bearing Calibration in Progress” appears. Observe if the compressor makes a distinctive knocking noise; this confirms the calibration is in progress. Do *not* click on “Save Calibration”.
7. Open the “Compressor Event Log” window. From the menu bar, select “Window”→ “Event Log”, or click on the “Event Log” icon located below the menu bar.

Verify that the following message is displayed:  
- “Bearing Calibration Performed”

Verify that the following error is *not* displayed:  
- “Bearing Error: Calibration Failed”

If the bearing calibration is reported to have failed, try to perform the bearing calibration one more time. If the bearing calibration is still not successful, contact Turbocor technical support.

8. For the following parameters in the “Startup Check Calibration Data” window, compare the values between

the “Latest Check” and the “Stored Calibration”; see 6.2.2 "Calibration Data Interpretation":

- FRX Gain
- FRY Gain
- BRX Gain
- BRY Gain
- AX Gain

## 6.2.2 Calibration Data Interpretation

### “Gain” Interpretation

- **One or more of the gains are zero**

*Interpretation: There is an electrical fault.*

Refer to the Troubleshooting Manual for the appropriate troubleshooting procedure.

## 6.3 Compressor Control

The “Compressor Controller” window allows the user to:

- Control the suction pressure at compressor start-up
- Set the compressor control mode
- Set the compressor loading demand
- Set the inlet guide vane opening
- View the current temperature and pressure sensor readings
- View the compressor control faults and alarms
- View the system messages

- **The difference between the “Latest Check” and “Stored Calibration” is less than 20% of the “Stored Calibration” value**

*Interpretation: Bearing calibration was successful.*

- **The difference between the “Latest Check” and “Stored Calibration” is greater than 20% of the “Stored Calibration” value**

*Interpretation: Excess carbon obstructing the shaft.*

Refer to the Troubleshooting Manual for the appropriate troubleshooting procedure.

### “Offset” Interpretation

Only the difference between the “Latest Check” offset and the “Stored Calibration” offset is important. The “Latest Check” offset value or the “Stored Calibration” offset value by itself has no significance. The change between the offset values signifies a change in the area of shaft orbit.

To view the “Compressor Controller” window, click on the “Compressor Controller Parameters” icon located below the menu bar. Table 6 provides a description of the compressor controller parameters.

### **IMPORTANT:**

To change a parameter setting, double-click the variable field, scroll or type in the new setting, and *press Enter*. It is important to press Enter as this causes the user input to be validated.

# Monitor Program Data and Controls

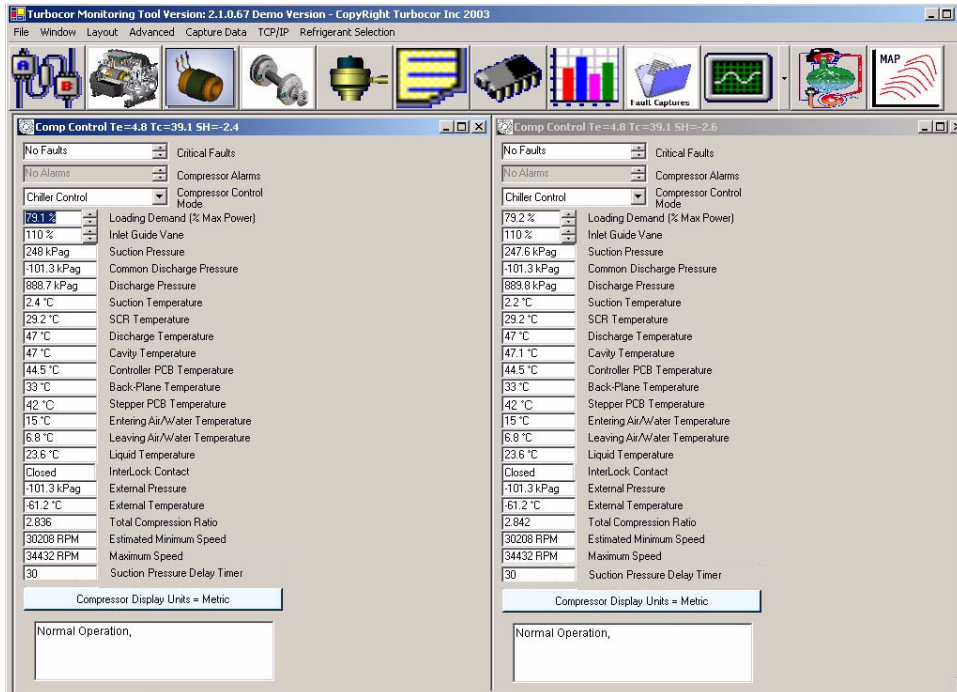

Figure 24 Compressor Controller Form

**Table 6 Compressor Controller Parameters**

Parameter	Description
Te (on title bar)	Evaporation Temperature
Tc (on title bar)	Condensation Temperature
SH (on title bar)	Superheat Calculation [Metric: °K; Imperial: °R] If the absolute superheat value is < 5, then the gas is wet and will cause the motor to overwork (as wet gas is heavier than dry gas).
Critical Faults	Displays the compressor's most recent active critical fault. Refer to 6.3.2 "Compressor Faults/Alarms" for further details.
Compressor Alarms	Displays the compressor's most recent active critical alarm. Refer to 6.3.2 "Compressor Faults/Alarms" for further details.
Compressor Control Mode	Selects the source of demand for the compressor: Calibration, Manual Control, Analog Input, Modbus Network, or Chiller Control. Refer to 6.3.1 "Compressor Control Modes" for further details.
Loading Demand (% max power)	Compressor Demand: requested motor power demand as a percentage of the maximum motor power [kW].
Inlet Guide Vane	% of Inlet guide vane opening, 0.0% means the vanes are at 90° to the pipe line (Fully closed). 110% means 10° over turned from fully open.
Suction Pressure	The actual suction gauge pressure at the compressor flange as measured by the suction pressure transducer.
Common Discharge Pressure	Used when an extra discharge pressure transducer is mounted to a common discharge line in the case of multiple compressors.
Discharge Pressure	The actual discharge gauge pressure at the compressor flange as measured by the discharge pressure transducer.
Suction Temperature	The actual suction temperature at the compressor flange as measured by the suction temperature/pressure transducer.
SCR Temperature	Temperature of the SCR heat sink plate.
Discharge Temperature	The actual discharge temperature at the compressor flange as measured by the discharge temperature/pressure transducer.
Cavity Temperature	Temperature of the superheated gas moving past the shaft.
Controller PCB Temperature	Temperature of the BMCC circuit board.
Backplane Temperature	Temperature of the backplane.
Stepper PCB Temperature	Temperature of the serial driver circuit board.
Entering Air/water Temperature	Temperature as measured by the 10K thermistor connected to the terminals marked "ENTRY" on the Compressor Interface module.
Leaving Air/water Temperature	Temperature as measured by the 10K thermistor connected to the terminals marked "LEAVE" on the Compressor Interface module.
Interlock Contact	Status of the digital input marked "I/LOCK" on the Compressor Interface module. Possible values are "OPEN" and "CLOSED". If condition is open the compressor will not run.
External Pressure	Gauge pressure as measured from a pressure transducer connected to the terminals marked "SPARE P" on the Compressor Interface module.

**Table 6 Compressor Controller Parameters (Continued)**

Parameter	Description
External Temperature	Temperature as measured from a thermistor connected to the terminals marked "SPARE T" on the Compressor Interface module.
Total Compression Ratio	Ratio of the absolute discharge pressure and the absolute suction pressure.
Estimated Minimum Speed	Estimated minimum RPM the compressor can run at with a fully open inlet guide vane.
Maximum Speed	Maximum RPM the compressor can run at for a given set of inlet and outlet conditions.
Suction Pressure Delay Timer	
Compressor Display Units Button	Changes the measurement unit used when button is pressed. The options are: <ul style="list-style-type: none"> <li>• Metric Units - kPa, °C, °K</li> <li>• Imperial Units - Psi, °F, °R</li> </ul>
System Messages	Describes the state of the system.
Start-up Settings - Suction Press Start Limit (% Trip)	Temporary alarm and trip limit for the suction pressure. The limit is set up as a % of the current suction pressure limit, e.g. if a suction pressure trip of 270 kPa was set and the suction pressure start limit was set to 50%, the temporary suction pressure trip limit would be 135 kPa. This temporary limit is only active while the Suction press start fault delay is timing down.
Start-up Settings - Suction Start Press Fault delay	Time in seconds that the temporary suction pressure alarm / fault limit should be enabled.
Start-up Settings - Suction Pressure Delay (Count down)	Current count down in seconds. The timer starts to count down once the shaft starts to rotate.

### 6.3.1 Compressor Control Modes

#### Calibration

In Calibration mode, the compressor prepares itself for calibration. Any external demand will be blocked from the system, i.e., any external computer, PLC, building management system, or automatic control will *not* be able to control the compressor.

In Calibration mode, the user may only calibrate the bearings. Refer to section 6.2 "Bearing Calibration" on page 20.

**NOTE:**

The compressor must be de-levitated, and the Compressor Interface interlock circuit must be open for the compressor to be calibrated.

#### Manual Control

In Manual Control mode, the user:

- Must set the "Loading Demand (% max power)" parameter from the "Compressor Control" window. Refer to 6.3 "Compressor Control".
- Must set the "Inlet Guide Vane" (% opening) from the "Compressor Control" window. Refer to 6.3 "Compressor Control".
- Must set the "Desired Shaft Speed (RPM)" parameter from the "Magnet Motor Monitoring" window. Refer to section 6.4 "Motor Monitoring" on page 28.
- May calibrate the bearings. Refer to section 6.2 "Bearing Calibration" on page 20.

Use Manual Control mode when servicing or troubleshooting the compressor.

**NOTE:**

In Manual Control mode, the Compressor Interface interlock switch has no effect on the compressor state.

**Analog Input**

The Analog Input mode controls the compressor loading using an analog demand signal of 0-10 VDC from an external controller. The variable demand signal corresponds to the range of 0-100% maximum power available.

**NOTE:**

The Compressor Interface interlock switch must be closed and no errors present for the compressor to start up and run.

**Modbus Network**

In Modbus Network mode, the compressor receives a demand from an external computer, PLC, or building management system using the Modbus protocol on a RS-232 or RS4-85 communication link.

In Modbus Network mode, the user may only set the "Loading Demand (% max power)" parameter from the "Compressor Controller" window. Refer to 6.3 "Compressor Control". All other parameters in the monitor program may only be viewed.

**NOTE:**

The Compressor Interface interlock switch must be closed and no errors present for the compressor to start up and run.

**Chiller Control**

The Chiller Control mode is fully automatic and controls the chilled water or air temperature using a temperature sensor connected directly to the Compressor Interface module. This mode can also be used to control evaporating

temperature which is derived from the suction pressure measurement.

**NOTE:**

The Compressor Interface interlock switch must be closed and no errors present for the compressor to start up and run.

**6.3.2 Compressor Faults/Alarms**

This section describes the possible "Critical Faults" and "Compressor Alarms" displayed in the "Compressor Controller" window. Table 7 provides a description of the possible cause of the fault/alarm.

If a compressor controller fault/alarm occurs, it is an indication that the EEPROM fault/alarm limit setting has been exceeded. Check that the EEPROM fault/alarm limit settings are adequate for the current compressor load. From the menu bar, select "Window" → "Eeprom Settings", or click on the "Eeprom Settings" icon located below the menu bar. Then select the "CC Trip Limits" tab to view the "Compressor General Fault Limits", or select the "CC Alarm Limits" tab to view the "Compressor General Alarm Limits". Refer to section 6.9 "EEPROM Settings" on page 39. If the current user access level does not permit viewing of the EEPROM settings, contact a service technician with a higher access level

If a fault or alarm occurs, refer to the Troubleshooting Manual for the appropriate procedure(s) to follow.

**NOTE:**

A "Compressor Alarm" will slow down the motor, whereas a "Critical Fault" will trip the motor. A "Compressor Alarm" occurs when a compressor parameter (e.g. temperature/pressure) has exceeded its alarm limit setting. A "Critical Fault" occurs when a compressor parameter has exceeded its fault limit setting.

**Table 7 Compressor Faults and Alarms**

Fault / Alarm	Possible Cause
Inverter Temperature Fault / Alarm	Insufficient motor cooling
Discharge Temperature Fault / Alarm	Insufficient charge (not enough gas)
Suction Pressure Fault / Alarm	Insufficient charge or insufficient system load
Discharge Pressure Fault / Alarm	Faulty condenser Note: A "Discharge Pressure" fault will lock out the compressor. The compressor will have to be powered down and restarted.

**Table 7 Compressor Faults and Alarms (Continued)**

Fault / Alarm	Possible Cause
3-Phase Over-Current Fault / Alarm	Excessive system load (usually due to compressor pumping liquid). Note: A "3 Phase Over Current" fault will lock out the compressor. The compressor will have to be powered down and restarted.
Cavity Temperature Fault / Alarm	Insufficient motor cooling
Leaving Water Temp Fault / Alarm	Insufficient water flow.
Compression Ratio Fault / Alarm	Faulty condenser or insufficient load on the evaporator.
BMC Fault	Faulty BMCC
Sensor Fault	Faulty sensor or faulty BMCC
SCR Temperature Fault / Alarm	Insufficient cooling to the SCR plate
Lock Out Fault	If any (or a combination of) the alarms listed below occurs more than 3 times within 30 minutes, a "Lock Out Fault" occurs: <ul style="list-style-type: none"> <li>• Inverter temperature alarm</li> <li>• Cavity temperature alarm</li> <li>• SCR temperature alarm</li> </ul>
Winding Temperature Fault	Motor winding temperature has exceeded 155°C

## 6.4 Motor Monitoring

### 6.4.1 Motor Monitoring Overview

The "Variable Speed Permanent Magnet Motor Monitoring" window allows the user to:

- View the actual shaft speed, and set the desired shaft speed
- View motor parameters such as current, voltage, and power
- View motor faults and alarms
- View the number of energized motor cooling solenoids
- View the Soft-Start Controller data

To view the "Variable Speed Permanent Magnet Motor Monitoring" window, select "Window" → "Motor" from the menu bar, or click on the "Motor Monitor" icon located

below the menu bar. Table 8 provides a description of the motor monitoring parameters.

**NOTE:**

The measurement unit (metric/imperial) displayed depends on the measurement unit previously set. To verify or change the measurement unit, refer to section 6.3 "Compressor Control" on page 23.

**IMPORTANT:**

To change a parameter setting, double-click the variable field, scroll or type in the new setting, and *press Enter*. It is important to press Enter as this causes the user input to be validated.

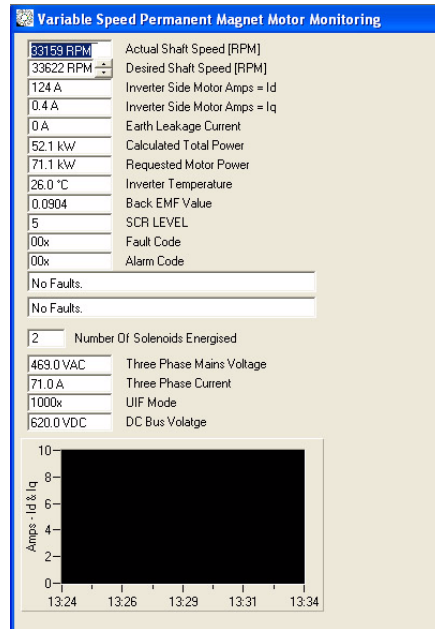
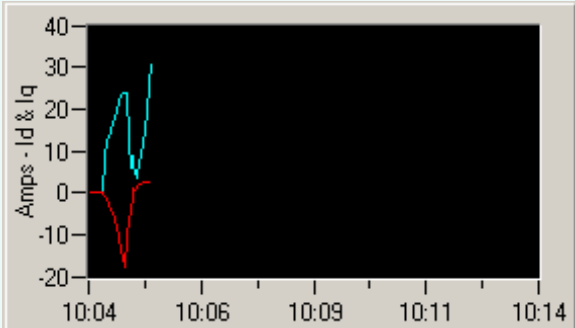

Figure 25 Motor Monitoring Form

Table 8 Motor Monitoring Parameters

Parameter	Description
<b>General Motor Data:</b>	
Actual Shaft Speed (RPM)	Actual shaft speed in RPM.
Desired Shaft Speed (RPM)	Commanding shaft speed in RPM (always higher than the actual shaft speed).
Inverter Side Motor Amps = Id	Current output from the IGBT Inverter to the motor. Torque-generating current component.
Inverter Side Motor Amps = Iq	Current output from the IGBT Inverter to the motor. Flux-generating current component.
Earth Leakage Current	Motor current that leaks to ground due to an insulation fault.
Calculated Total Power	Calculated 3-phase input power in kW.
Requested Motor Power	Requested motor power in kW. Value is a function of the compressor model designation and demand percentage. The demand percentage is set through the "Loading Demand (% max power)" in the "Compressor Controller" window. Refer to section 6.3 "Compressor Control" on page 23.
Inverter Temperature	Inverter temperature as measured by thermistor mounted under the IGBT Inverter.
Back EMF Value	Internal motor voltage
SCR Level	
Fault Code	Hexadecimal motor fault code from the bearing motor control.
Alarm Code	Hexadecimal motor alarm code from the bearing motor control.

**Table 8 Motor Monitoring Parameters (Continued)**

Parameter	Description
Fault Text Box	Displays the motor's most recent active fault. Refer to 6.4.2 "Motor Faults / Alarms" for alarm details.
Alarm Text Box	Displays the motor's most recent active alarm. Refer to 6.4.2 "Motor Faults / Alarms" for fault details.
<b>Motor Cooling:</b>	
Number of solenoids energized	Indicates the number of motor-cooling solenoids that are open.
<b>Soft Start Data:</b>	
Three-Phase Mains Voltage	Calculated three phase mains voltage.
Three-Phase Current	Calculated three phase mains current.
DC Bus Regulation	Percentage of maximum DC Bus output voltage.
DC Bus Voltage	DC Bus Voltage as measured at the inverter
Graph: Amps Id & Iq	<p>Graphical representation of the torque-generating current (Id) and the flux-generating current (Iq) versus time.</p> <p>Under normal conditions, when the motor is driving, Iq should decrease to at least -1 during compressor start-up, and the "Amps - Id &amp; Iq" graph should look like:</p>  <p>The turquoise line represents Id, and the red line represents Iq.</p> <p>Notice that the red line (Iq) dips to negative values. If Iq does not decrease to negative values during compressor start-up, then there is no motor drive.</p> <p>Id should stabilize towards the torque value; Iq should stabilize towards zero at medium motor speeds, and increase with positive values at high motor speeds.</p>

**6.4.2 Motor Faults / Alarms**

This section describes the possible faults displayed in the "Variable Speed Permanent Magnet Motor Monitoring"

window. Table 9 provides a description of the possible cause of the fault/alarm. If a fault or alarm occurs, refer to the Troubleshooting Manual for the appropriate procedure(s) to follow.

**NOTE:**

A motor alarm will slow down the motor, whereas a motor fault will trip the motor.

**Table 9 Motor Faults and Alarms**

Fault / Alarm	Possible Cause
Motor Single Phase Over-Current Detected	Excess liquid at the suction valve, thus causing the motor to overwork and generate too much current.
DC Bus Over-Voltage Detected	DC bus voltage exceeds acceptable voltage range.
Motor High Current Warning	The AC input voltage is too low, or the compressor is overloaded (due to wet gas or exceeded compressor capacity).
Motor High Current Fault	The AC input voltage is too low, or the compressor is overloaded (due to wet gas or exceeded compressor capacity).
Inverter Error Signal	Faulty IGBT Inverter
Over-Current During Startup - Rotor May Be Locked	Too much current output to the shaft (rotor) during compressor start-up.
Bearing Warning Active	The shaft is out of orbit, the compressor communication is affected by noise, or there is excessive compressor load.
Bearing Error Active	Shaft is blocked or the bearings are faulty.
Output voltage on the motor	Faulty IGBT Inverter.
Soft Start Error Detected	Faulty Soft Start Controller.
24Vdc Fault	Faulty 24VDC supply.
Motor back EMF is low.	Motor magnet strength is weak, possibly caused by insufficient motor cooling.
EEPROM checksum error.	Faulty BMCC.
Generator mode active	Compressor is coasting down due to loss of power supply.
SCR phase loss	Excessive imbalance may exist between the phases.

## 6.5 Magnetic Bearing Monitoring

### 6.5.1 Bearing Monitoring Overview

The “Magnetic Bearing Monitoring” window allows the user to:

- Change the shaft levitation state
- View the shaft unbalance percentage
- View the current required to counteract the shaft unbalance
- View bearing faults and alarms

To view the “Magnetic Bearing Monitoring” window, select “Window”→ “Bearing” from the menu bar, or click on the “Magnetic Bearings” icon located below the menu bar. Table 10 provides a description of the bearing monitoring parameters.

**IMPORTANT:**

To change a parameter setting, double-click the variable field, scroll or type in the new setting, and *press Enter*. It is important to press Enter as this causes the user input to be validated.

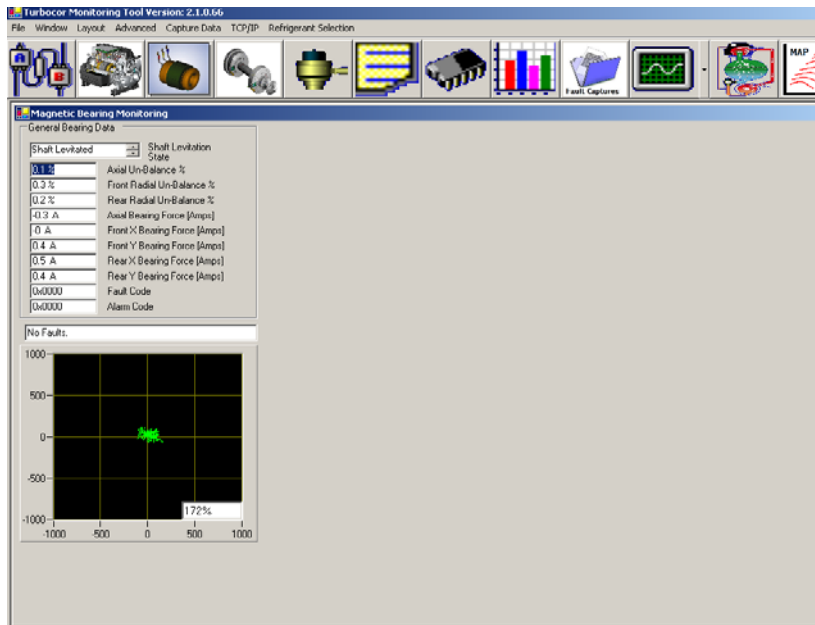

Figure 26 Magnetic Bearing Monitoring Form

Table 10 Bearing Monitoring Parameters

Parameter	Description
Shaft Levitation State	<p>Shaft state control.</p> <p>When in the “Shaft Levitated” state, click the up arrow to change to the “Shaft De-Levitated” state</p> <p>When in the “Shaft De-Levitated” state, click the down arrow to change to the “Shaft Levitated” state</p> <p><i>Note:</i> Shaft state may only be changed while in Manual Control Mode. Refer to section 6.3 "Compressor Control" on page 23.</p>
Axial Unbalance %	Percentage unbalance of total allowable axial displacement.
Front Radial Unbalance %	Percentage unbalance of total allowable front radial displacement.
Rear Radial Unbalance %	Percentage unbalance of total allowable rear radial displacement.
Axial Bearing Force (Amps)	Current required to counteract axial unbalance force.
Front X Bearing Force (Amps)	Current required to counteract front x unbalance force.
Front Y Bearing Force (Amps)	Current required to counteract front y unbalance force.
Rear X Bearing Force (Amps)	Current required to counteract rear x unbalance force.
Rear Y Bearing Force (Amps)	Current required to counteract rear y unbalance force.
Fault Code	Hexadecimal bearing fault code from the bearing motor control.

**Table 10 Bearing Monitoring Parameters (Continued)**

Parameter	Description
Alarm Code	Hexadecimal bearing alarm code from the bearing motor control.
Fault Text Box	Displays the most recent active bearing fault. Refer to 6.5.2 "Bearing Faults" for fault details.
Graph	Graphical representation of the front radial orbit of the shaft.  Percentile shown at the bottom right-hand corner indicates the average front orbit displacement.  <i>Note:</i> The domain of the graph shows half of the allowable area of shaft displacement. However, if the shaft orbit is shown to exceed 500 units in any direction, then there is excessive shaft vibration, possibly caused by a surge of gas flow.

### 6.5.2 Bearing Faults

This section describes the possible faults displayed in the “Magnetic Bearing Monitoring” window. Table 11 provides a description of the possible cause of the fault. If a fault occurs, refer to the Troubleshooting Manual for the appropriate procedure(s) to follow.

**Table 11 Bearing Faults**

Fault	Possible Cause
Calibration Failed	Manual calibration performed on compressor failed.
Startup Check Failed	Automatic calibration during compressor startup failed.
Axial Displacement Fault	Current force exerted on the axial bearing exceeds 60% of the calibration value.
Front Radial Displacement Fault	Current force exerted on the front radial bearing exceeds 60% of the calibration value.
Rear Radial Displacement Fault	Current force exerted on the rear radial bearing exceeds 60% of the calibration value.
Axial Static Load	Current force exerted on the axial bearing exceeds 2.5 amps.
Front Radial Static Load	Current force exerted on the front radial bearing exceeds 2.5 amps.
Back Radial Static Load	Current force exerted on the back radial bearing exceeds 2.5 amps.

### 6.6 Electronic Valve Data / Tuning

The “Electronic Valve Data / Tuning” window allows the user to:

- Control the electronic expansion valve stepper motors
- Control the analog output

To view the “Electronic Valve Data / Tuning” window, select “Window”→ “Expansion Valves” from the menu bar, or click on the “Expansion Valves” icon located below the menu bar.

To access the stepper motor control settings, select the “Stepper Motor” tab. The “EXV#1 Control Settings” controls the stepper motor connected to “EXV1” on the

## Monitor Program Data and Controls

Compressor Interface module. Similarly, the “EXV#2 Control Settings” controls the stepper motor connected to “EXV2” on the Compressor Interface module. Table 12 describes the stepper motor control parameters.

To access the analog output controls, select the “Analogue Output” tab. The “Analog Output Controls” controls the output labeled “Analog” on the Compressor Interface module. Table 13 describes the analog output control parameters.

### NOTE:

The measurement unit (metric/imperial) displayed depends on the measurement unit previously set. To verify or change

the measurement unit, refer to section 6.3 "Compressor Control" on page 23.

### IMPORTANT:

To change a parameter setting, double-click the variable field, scroll or type in the new setting, and *press Enter*. It is important to press Enter as this causes the user input to be validated.

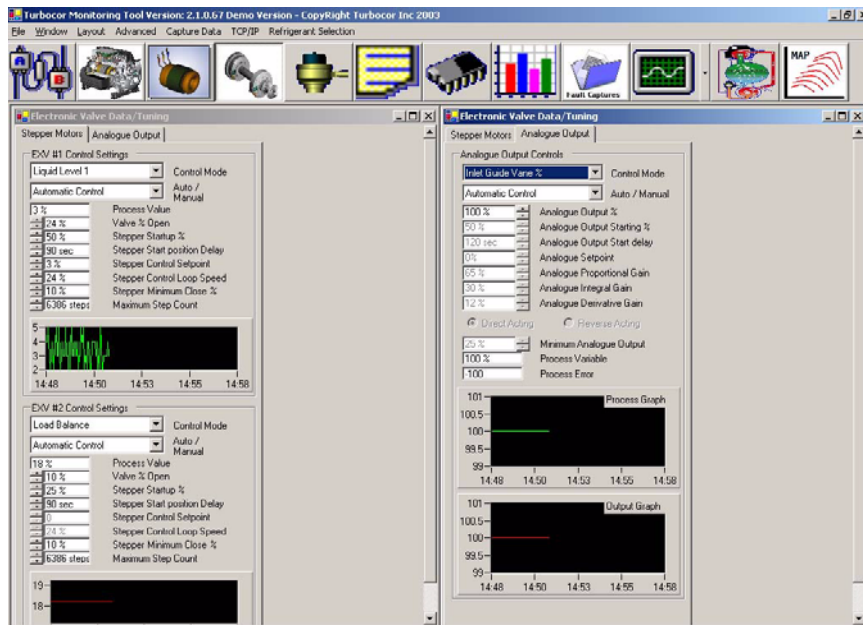

Figure 27 Electronic Valve Data / Tuning Form

**Table 12 Electronic Valve Data / Tuning Parameters (Stepper Motors)**

Parameter	Description
Control Mode	Selects which control variable will be maintained by the stepper motor output. The options are: <ol style="list-style-type: none"> <li>1. Superheat control using the compressor flange temperature and pressure (this mode is not recommended as the temperature at the compressor flange is influenced by external factors).</li> <li>2. Superheat control using the compressor flange pressure and a 10K thermistor that is connected to the terminals labeled "ENTRY" on the Compressor Interface module.</li> <li>3. Superheat control using the compressor flange pressure and a 10K thermistor that is connected to the terminals labeled "LIQT" on the Compressor Interface module.</li> <li>4. Superheat control using an external temperature and pressure sensor connected to the terminals labeled "SPARE T" &amp; "SPARE P" on the Compressor Interface module.</li> <li>5. Liquid Level 1 control using a level sensor connected to the terminals on the Compressor Interface module labeled "LIQ LEV1".</li> <li>6. Liquid Level 2 control using a level sensor connected to the terminals on the Compressor Interface module labeled "LIQ LEV2".</li> <li>7. Load Balance control uses the compressor's own internal control algorithm to determine the best mix of speed control, inlet guide vane opening and load balance valve opening.</li> </ol>
Auto/Manual	In automatic mode the compressor has complete control over the stepper motor output. In Manual mode the user is able to enter the valve position.
Process Value	Value of the controlled variable selected from the Control Mode.
Valve % Open	Ratio of the actual number of steps sent to the stepper motor over the maximum number of steps the motor is allowed to drive.
Stepper Startup %	Percentage of maximum steps sent to the motor on start of the compressor. The stepper motor will hold at this position until the stepper start delay timer has expired.
Stepper Start Position Delay	Amount of time from compressor start to hold the number of steps sent to the motor at the stepper startup %. Value is in seconds and starts to count down when the drive enables.
Stepper Control Setpoint	Desired value of the controlled variable.
Stepper Control Loop Speed	Reaction time of the control loop to a process error.
Stepper Minimum Close %	The minimum close position for the valve while the compressor is spinning.
Maximum Step Count	Number of steps from fully closed to fully open for the installed stepper motor driven device.
Graph	Displays the "Process Value" parameter with respect to time. The time corresponds to the PC system time, and is displayed in HH:MM format.

**Table 13 Electronic Valve Data / Tuning Parameters (Analog Output)**

Parameter	Description
Control Mode	Selects which control variable will be maintained by the 0 -10 VDC output labeled "ANALOG" on the Compressor Interface module. The options are: <ul style="list-style-type: none"> <li>• Load Balance Valve</li> <li>• Discharge Pressure</li> <li>• Inlet Guide Vane %</li> <li>• Superheat – Flange TP</li> <li>• Superheat – FlangeP, EWT</li> <li>• Superheat – FlangeP, LIQT</li> <li>• Suction Pressure</li> <li>• Leaving Temp</li> <li>• Entering Temp</li> <li>• Liquid Temp</li> </ul>
Auto/Manual	Selects the compressor control mode. In automatic mode the compressor has complete control over the stepper motor output. In Manual mode the user is able to enter the valve position.
Analog Output %	Actual percentage of the maximum voltage sent to the output.
Analog Output Starting %	Percentage of maximum voltage sent to the terminals on start of the compressor. The analog output will hold at this position until start delay timer has expired.
Analog Output Start Delay	Amount of time from compressor start to hold the voltage at the startup percentage. Value is in seconds and starts to count down when the drive enables.
Analog Setpoint	Desired value of the controlled variable.
Analog Proportional Gain	Controller Proportional Gain
Analog Integral Gain	Controller Integral Gain
Analog Derivative Gain	Controller Derivative Gain
Direct Acting/ Reverse Acting	Control action. Direct Acting: output increases as process variable increases. Reverse Acting: output decreases as process variable increases.
Minimum Analog Output	The minimum voltage output while the compressor is spinning.
Process Variable	Value of the controlled variable.
Process Error	Difference between the analog setpoint and the process variable.
Process Graph	Plots the process variable (selected from the Control Mode) versus time. Time is the PC system time, and is displayed in HH:MM format.
Output Graph	Plots the percentage of the maximum output voltage versus time. Time is the PC system time, and is displayed in HH:MM format.

## 6.7 Chiller Control

The "Chiller Control" window allows the user to control one of the following:

- Leaving chiller water or air temperature
- Entering chiller water or air temperature
- Evaporating (saturated suction) temperature

To view the “Chiller Control” window, select “Window”→ “Chiller Control” from the menu bar, or click on the “Chiller Control” icon located below the menu bar. Table 14 provides details about the chiller controller parameters.

**NOTE:**

The measurement unit (metric/imperial) displayed depends on the measurement unit previously set. To verify or change the measurement unit, refer to section 6.3 "Compressor Control" on page 23.

**IMPORTANT:**

To change a parameter setting, double-click the variable field, scroll or type in the new setting, and *press Enter*. It is important to press Enter as this causes the user input to be validated.

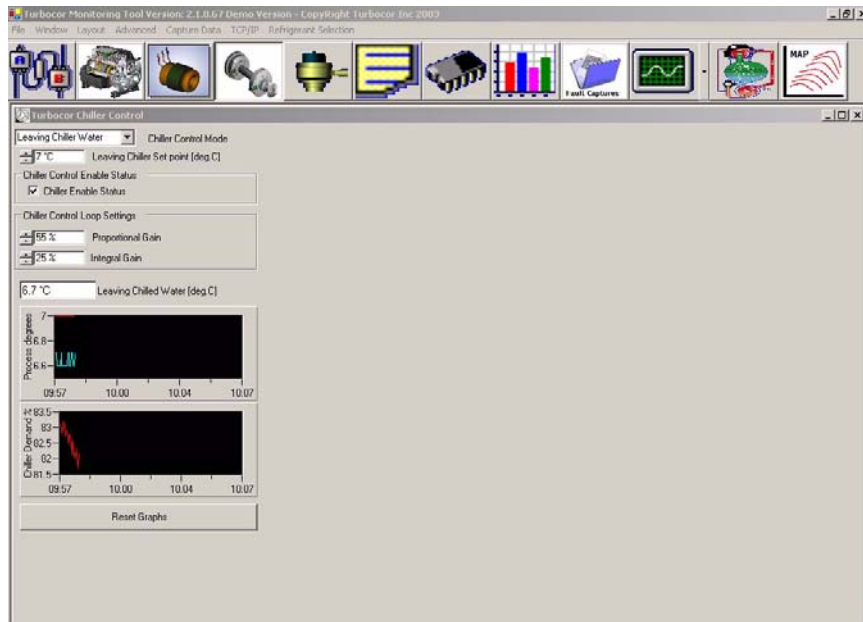

Figure 28 Chiller Control Form

**Table 14 Chiller Controller Parameters**

Parameter	Description
Chiller Control Mode	Selection of the sensor that the chiller control will try to maintain the value of. The options are: <ul style="list-style-type: none"> <li>• Leaving Chiller Water: Controls the water or air temperature leaving the chiller.</li> <li>• Entering Chiller Water: Controls water or air temperature entering the chiller.</li> <li>• Evaporating Temperature: Controls the evaporating (saturated suction) temperature.</li> </ul>
Chiller Control Set Point	The control set point is the value at which the controlled variable shall be maintained. The controlled variable depends on the Chiller Control Mode selected: <ul style="list-style-type: none"> <li>• Leaving Chiller Set Point [deg.C / deg.F]: the controlled variable is either the leaving chiller water or air temperature.</li> <li>• Entering Chiller Set Point [deg.C / deg.F]: the controlled variable is either the entering chiller water or air temperature.</li> <li>• Evaporating Temperature Set Point [deg.C / deg.F]: the controlled variable is the evaporating (saturated suction) temperature.</li> </ul>
<b>Chiller Control Enable Status</b>	
Chiller Enable Status	Checked: chiller able to run Unchecked: chiller will not run.
<b>Chiller Control Loop Settings:</b>	
Proportional Gain	Control loop - Proportional gain, 0 to 100%.
Integral Gain	Control loop - Integral gain or reset, 0 to 100%.
Control Variable Temperature	Indication of the current value of the controlled variable. Controlled variable depends on the Chiller Control Mode selected: <ul style="list-style-type: none"> <li>• Leaving Chiller Water [deg.C / deg.F]</li> <li>• Entering Chiller Water [deg.C / deg.F]</li> <li>• Evaporating Temperature [deg.C / deg.F]</li> </ul>
Graph: Process	Graphical representation of the current value of the controlled variable (turquoise line) and the control set point (red line).
Graph: Chiller Demand %	Graphical representation of the current demand output from the chiller control algorithm.
Reset Graphs Button	Clears all data in the charts.

## 6.8 System Information

To access the “System Information” window, select “Advanced”→ “System Information” from the menu bar.

The “System Information” window displays the current DSP time (i.e. real time) and the current system time (i.e.

PC system time). Clicking on the “Reset Real Time Clock to System Time” synchronizes the DSP time with the system time.

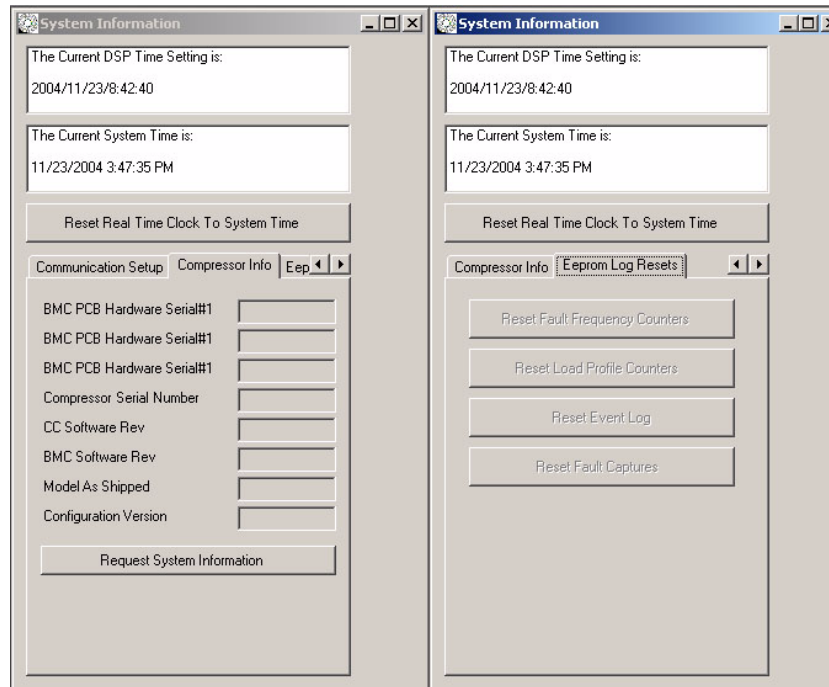

Figure 29 System Information

### 6.8.1 Compressor Info

Selecting the “Compressor Info” tab allows the user to view the system information. Specifically, it allows the user to view the:

- Compressor model and serial #
- BMC PCB hardware serial #
- Software revision installed
- Configuration version

Click on the “Request System Information” button to obtain the system information.

### 6.8.2 EEPROM Log Resets

Selecting the “Eeprom Log Resets” tab allows the user to:

- Reset the fault frequency counters
- Reset the fault captures
- Reset the load profile counters (i.e. the power demand counters)
- Reset the event log

The “Eeprom Log Resets” is only accessible by authorized service personnel.

## 6.9 EEPROM Settings

To access the “EEPROM Settings”, select “Window” → “Eeprom Settings” from the menu bar, or click on the “Eeprom Settings” icon located below the menu bar.

#### NOTE:

Viewing and/or modifying the EEPROM settings is restricted to users with mid level or high level access codes.

### 6.9.1 Compressor Controller Settings

Select the “CC\_Control” tab to view the following:

- Monitor program measurement unit selected
- Compressor Control Mode

- Chiller Control Parameters
- Compressor Startup Parameters

The compressor controller parameters are described in Table 15.

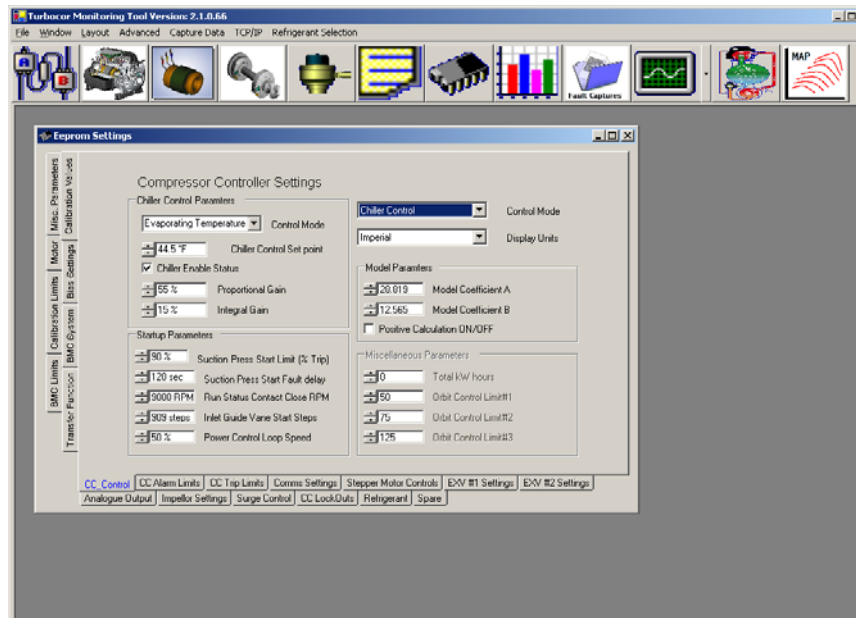

Figure 30 EEPROM Settings - Compressor Controller Settings

Table 15 EEPROM Settings - Compressor Controller Parameters

Parameter	Description
Control Mode	Displays the source of demand for the compressor: Calibration, Manual Control, Analog Input, Modbus Network, or Chiller Control. Refer to 6.3.1 "Compressor Control Modes" on page 26 for further details.
Display Units	Displays the measurement unit used. The options are: <ul style="list-style-type: none"> <li>• Metric Units - kPa, °C, °K</li> <li>• Imperial Units - Psi, °F, °R</li> </ul> Refer to 6.3.1 "Compressor Control Modes" for details on how to change the measurement unit.
<b>Chiller Control Parameters:</b>	Refer to 6.7 "Chiller Control" on page 36 for further details.

**Table 15 EEPROM Settings - Compressor Controller Parameters (Continued)**

Parameter	Description
Control Mode	Displays the sensor that the chiller control will try to maintain the value of. The options are: <ul style="list-style-type: none"> <li>Leaving Chiller Water: Controls the water or air temperature leaving the chiller.</li> <li>Entering Chiller Water: Controls water or air temperature entering the chiller.</li> <li>Evaporating Temperature: Controls the evaporating (saturated suction) temperature.</li> </ul>
Chiller Control Set Point	Value at which the controlled variable (selected through “Control Mode”) shall be maintained.
Chiller Enable Status	Checked: chiller able to run Unchecked: chiller will not run
Proportional Gain	Control loop - Proportional gain, 0 to 100%.
Integral Gain	Control loop - Integral gain or reset, 0 to 100%.
<b>Startup Parameters:</b>	<b>Refer to 6.3 "Compressor Control" on page 23 for further details.</b>
Suction Press Start Limit (% Trip)	Temporary alarm and trip limit for the suction pressure. The limit is set up as a percentage of the current suction pressure limit, e.g. if a suction pressure trip of 270 kPa was set and the suction pressure start limit was set to 50% the temporary suction pressure, trip limit would be 135 kPa. This temporary alarm is only active while the Suction press start fault delay is timing down.
Suction Press Start Fault Delay	Time in seconds that the temporary suction pressure alarm / fault limit should be enabled.
Run Status Contact Close RPM	Speed at which the “Run” contact on Compressor Interface module closes.
Inlet Guide Vane Start Steps	Number of Inlet Guide Vane steps at compressor startup.
Power Control Loop Speed	PID loop gain for control of motor power.

### 6.9.2 Compressor Controller Alarms

Select the “CC Alarm Limits” tab to view the compressor general alarm limits. Table 16 describes the general alarm limits.

The limits represent the maximum temperature and/or pressure values the compressor will tolerate before activating an alarm.

Once an alarm is activated, the compressor motor will slow down, and the alarm will be reported in the “Compressor Controller” window as well as in the “Event Log” window.

An authorized user may change the temperature and/or pressure limits to adapt to the application needs. Note however, that the “Inverter Temperature” and the “SCR Temperature” alarm limits cannot be altered, as changing these limits may cause the compressor to malfunction.

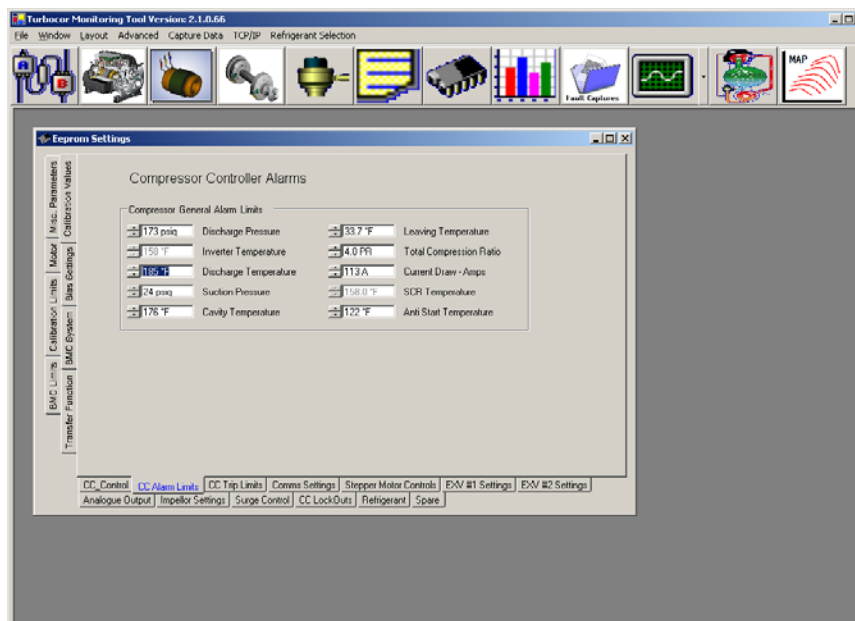

**Figure 31 EEPROM Settings - Compressor Controller Alarm Limits**

**Table 16 EEPROM Settings - Compressor Controller Alarm Limit Parameters**

Parameter	Description
Discharge Pressure	The actual discharge gauge pressure at the compressor flange as measured by the discharge pressure transducer.
Inverter Temperature	Inverter temperature as measured by thermistor mounted under the IGBT Inverter.
Discharge Temperature	The actual discharge temperature at the compressor flange as measured by the discharge temperature/pressure transducer.
Suction Pressure	The actual suction gauge pressure at the compressor flange as measured by the suction pressure transducer.
Cavity Temperature	Temperature of the superheated gas moving past the shaft.
Leaving Temperature	Leaving water temperature as measured from the 10K thermistor connected to the terminals marked "LEAVE" on the Compressor Interface module.
Total Compression Ratio	Ratio of the absolute discharge pressure and the absolute suction pressure.
Current Draw - Amps	3-phase mains input current.
SCR Temperature	Temperature of the SCR heat sink plate.
Anti Start Temperature	IGBT Inverter temperature limit at compressor startup.

### 6.9.3 Compressor Controller Fault Limits

Select the “CC Trip Limits” tab to view the compressor general fault limits. Table 17 describes the general trip limits.

The limits represent the maximum temperature and/or pressure values the compressor will tolerate before activating a fault.

Once a fault occurs, the compressor motor will trip and the fault will be reported in the “Compressor Controller” window as well as in the “Event Log” window.

An authorized user may change the following fault limits to adapt to the application needs:

- Suction Pressure
- Leaving Temperature
- Total Compression Ratio

All other fault limits cannot be altered, as changing these limits may cause the compressor to malfunction.

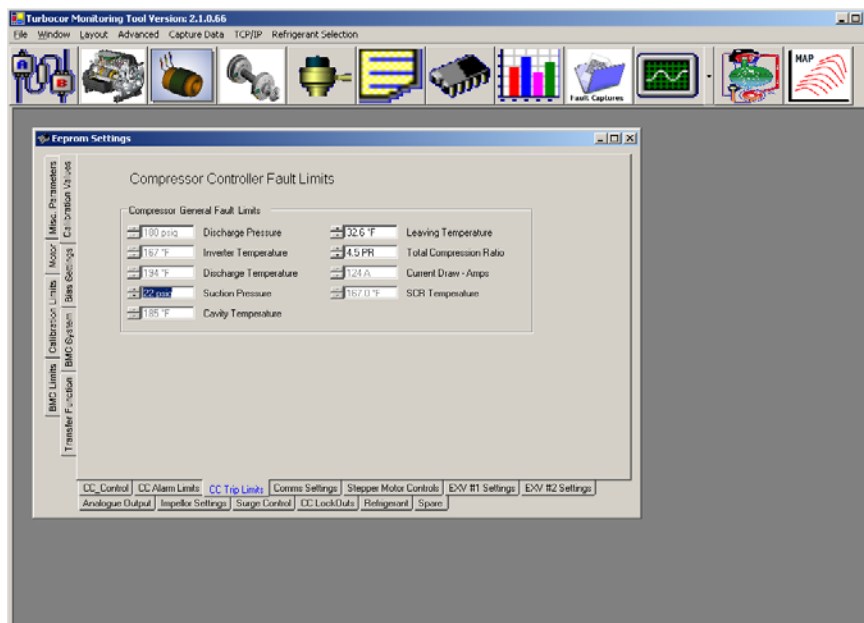

Figure 32 EEPROM Settings - Compressor Controller Fault Limits

**Table 17 EEPROM Settings - Compressor Controller Fault Limit Parameters**

Parameter	Description
Discharge Pressure	The actual discharge gauge pressure at the compressor flange as measured by the discharge pressure transducer.
Inverter Temperature	Inverter temperature as measured by thermistor mounted under the IGBT Inverter.
Discharge Temperature	The actual discharge temperature at the compressor flange as measured by the discharge temperature/pressure transducer.
Suction Pressure	The actual suction gauge pressure at the compressor flange as measured by the suction pressure transducer.
Cavity Temperature	Temperature of the superheated gas moving past the shaft.
Leaving Temperature	Leaving water temperature as measured from the 10K thermistor connected to the terminals marked "LEAVE" on the Compressor Interface module.
Total Compression Ratio	Ratio of the absolute discharge pressure and the absolute suction pressure.
Current Draw - Amps	3-phase mains input current.
SCR Temperature	Temperature of the SCR heat sink plate.
Anti Start Temperature	Temperature limit at which the compressor will start up. If the inverter temperature, cavity temperature, or SCR temperature exceeds the anti-start temperature, then the compressor will not start up until the temperature has been reduced.

### 6.9.4 Compressor Stepper Motor Settings

Select the "Stepper Motor Controls" tab to view and change the compressor's stepper motor settings. Specifically, it allows the user to view the maximum motor steps and the initial motor steps at compressor startup. For the electronic

expansion valves, the user may adjust the settings to meet the application needs.

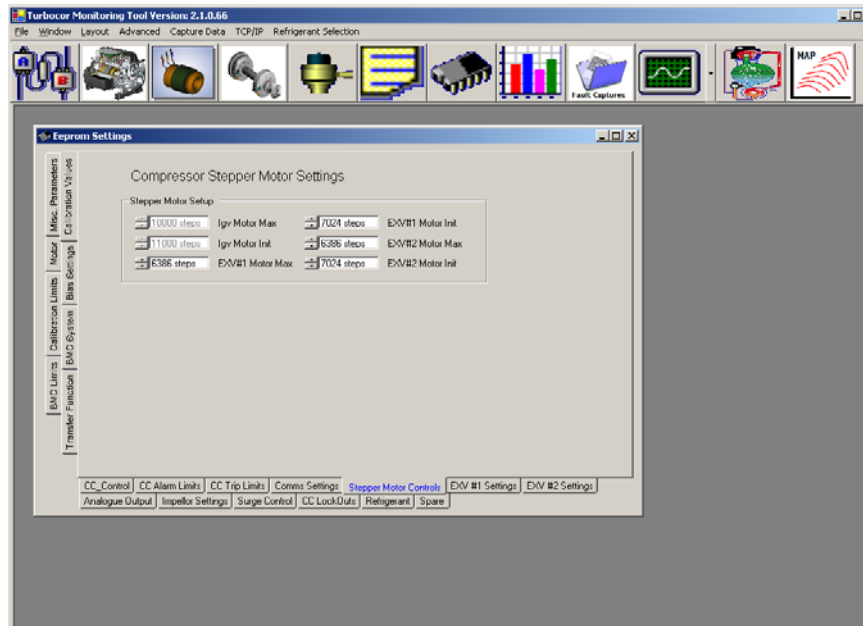

**Figure 33 EEPROM Settings - Stepper Motor Settings**

### 6.9.5 Stepper Motor Valve Controls

Select the “EXV#1 Settings” tab to view the control settings for the electronic expansion valve #1 (EXV#1). EXV#1 refers to the electronic expansion valve connected to “EXV1” at the Compressor Interface module.

Similarly, select the “EXV#2 Settings” tab to view the control settings for the electronic expansion valve #2 (EXV#2). EXV#2 refers to the electronic expansion valve connected to “EXV2” at the Compressor Interface module.

Table 18 describes the EXV settings. To update the EXV settings, refer to section 6.6 "Electronic Valve Data / Tuning" on page 33.

# Monitor Program Data and Controls

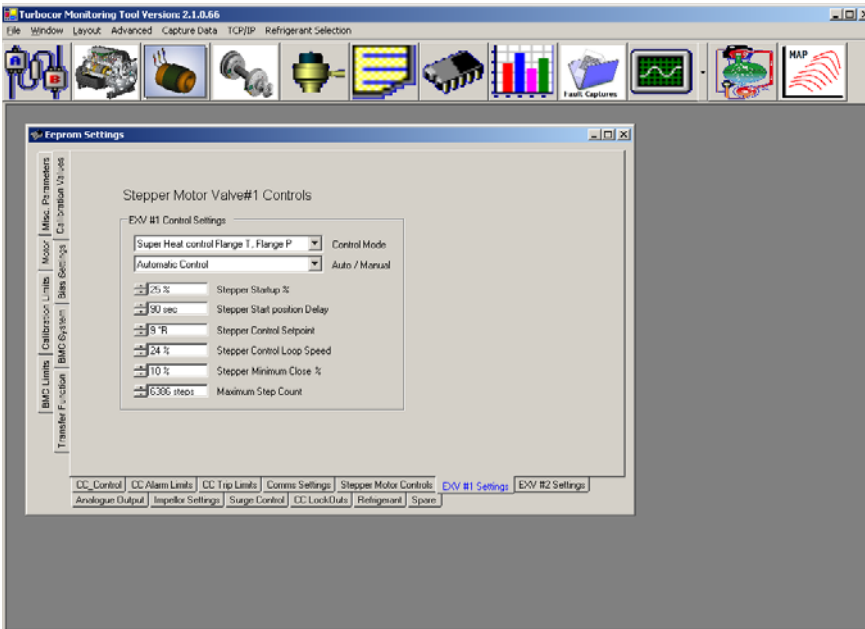

Figure 34 EEPROM Settings - Stepper Motor Valve #1 Controls

**Table 18 EEPROM Settings - EXV Parameters**

Parameter	Description
Control Mode	Displays which control variable will be maintained by the stepper motor output. The options are: <ol style="list-style-type: none"> <li>1. Superheat control using the compressor flange temperature and pressure (this mode is not recommended as the temperature at the compressor flange is influenced by external factors).</li> <li>2. Superheat control using the compressor flange pressure and a 10K thermistor that is connected to the terminals labeled "ENTRY" on the Compressor Interface module.</li> <li>3. Superheat control using the compressor flange pressure and a 10K thermistor that is connected to the terminals labeled "LIQT" on the Compressor Interface module.</li> <li>4. Superheat control using an external temperature and pressure sensor connected to the terminals on the IO pcb labeled "SPARE T" &amp; "SPARE P".</li> <li>5. Liquid Level 1 control using a level sensor connected to the terminals on the Compressor Interface module labeled "LIQ LEV1".</li> <li>6. Liquid Level 2 control using a level sensor connected to the terminals on the Compressor Interface module labeled "LIQ LEV2".</li> <li>7. Load Balance control uses the compressors own internal control algorithm to determine the best mix of speed control, inlet guide vane opening and load balance valve opening.</li> </ol>
Auto/Manual	Displays the compressor control mode. In automatic mode the compressor has complete control over the stepper motor output. In Manual mode the user is able to enter the valve position.
Stepper Startup %	Percentage of maximum steps sent to the motor on start of the compressor. The stepper motor will hold at this position until stepper start delay timer has expired.
Stepper Start Position Delay	Amount of time from compressor start to hold the number of steps sent to the motor at the stepper startup %. Value is in seconds and starts to count down when the drive enables.
Stepper Control Setpoint	Desired value of the controlled variable.
Stepper Control Loop Speed	Reaction time of the control loop to a process error.
Stepper Minimum Close %	The minimum close position for the valve while the compressor is spinning.
Maximum Step Count	Number of steps from fully closed to fully open for the installed stepper motor driven device.

### 6.9.6 Analog Output Controls

Select the "Analog Output" tab to view the analog output control settings. The Analog Output Control Settings control the output labeled "Analog" on the Compressor Interface module.

Table 19 provides details about the analog output control settings. To update the settings, refer to section 6.6 "Electronic Valve Data / Tuning" on page 33.

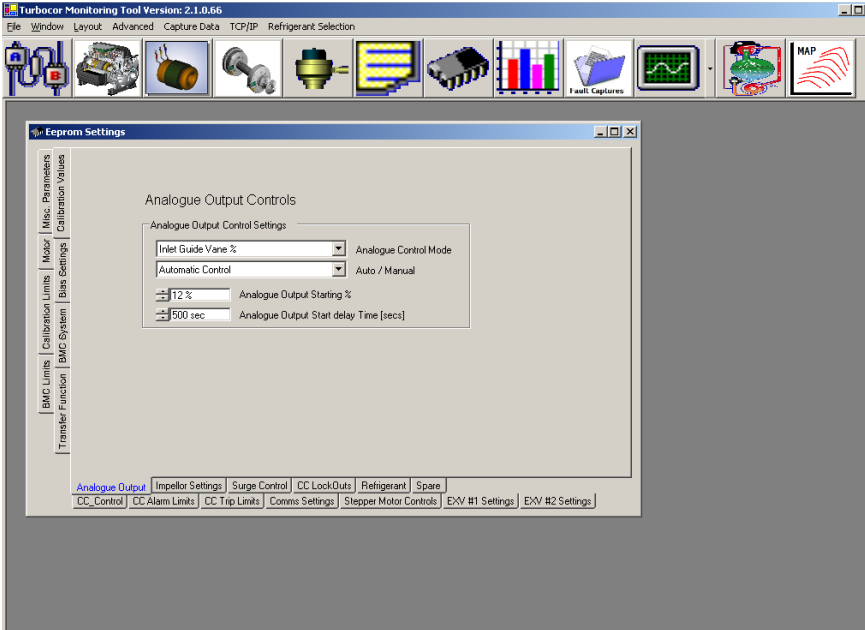

Figure 35 EEPROM Settings - Analog Output Controls

**Table 19 Electronic Valve Data / Tuning Parameters (Analog Output)**

Parameter	Description
Analog Control Mode	Selects which control variable will be maintained by the 0-10VDC output labeled "ANALOG" on the Compressor Interface module. The options are: <ul style="list-style-type: none"> <li>• Load Balance Valve</li> <li>• Discharge Pressure</li> <li>• Inlet Guide Vane %</li> <li>• Superheat – Flange TP</li> <li>• Superheat – FlangeP, EWT</li> <li>• Superheat – FlangeP, LIQT</li> <li>• Suction Pressure</li> <li>• Leaving Temp</li> <li>• Entering Temp</li> <li>• Liquid Temp</li> </ul>
Auto/Manual	Selects the compressor control mode. In automatic mode the compressor has complete control over the stepper motor output. In Manual mode the user is able to enter the valve position.
Analog Output Starting %	Percentage of maximum voltage sent to the terminals on start of the compressor. The analog output will hold at this position until start delay timer has expired.
Analog Output Start Delay	Amount of time from compressor start to hold the voltage at the startup percentage. Value is in seconds and starts to count down when the drive enables.

### 6.9.7 Compressor Controller Impeller Specific Settings

are those that define the operational envelope of the specific compressor model.

Select the "Impeller Settings" tab to view the compressor controller impeller specific settings. The parameters shown

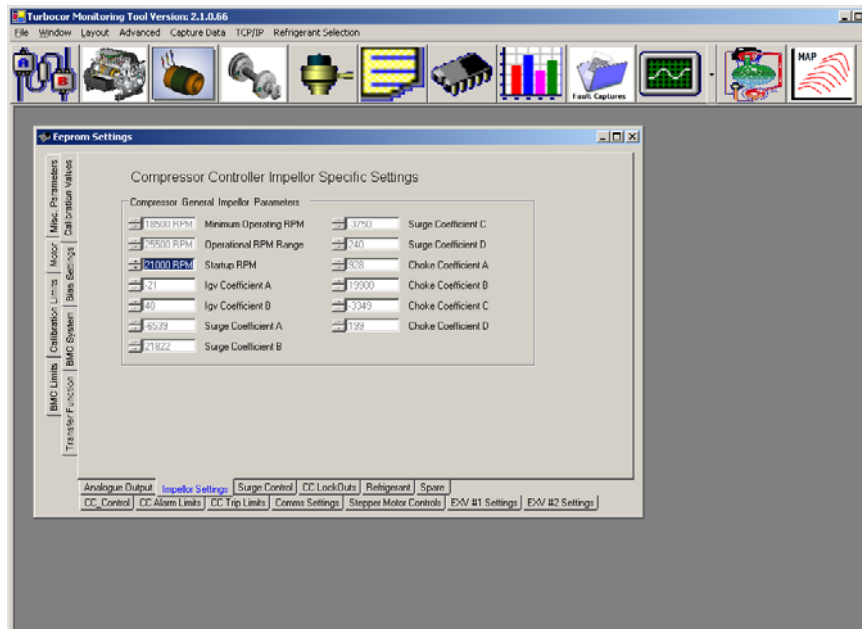

**Figure 36 EEPROM Settings - Compressor Controller Impeller Specific Settings**

### 6.9.8 Compressor Controller (CC) Critical Fault Lock Outs

Select the “CC LockOuts” tab to view the setup for the CC critical fault lock outs.

The “Number of Drive Cooling System Alarms In Buffer” represents the number of times the following alarms have occurred within the “Moving Window Hold Time” of 30 minutes:

- Anti-start temperature alarm

- Inverter temperature alarm
- Cavity temperature alarm
- SCR temperature alarm

The compressor will continue to operate even if the aforementioned alarms occur.

However, if any (or a combination of) the aforementioned alarms occurs more than the allowable “Limit of Alarms in Buffer”, within the “Moving Window Hold Time” of 30 minutes, then a “Lock Out Fault” occurs and the motor will trip.

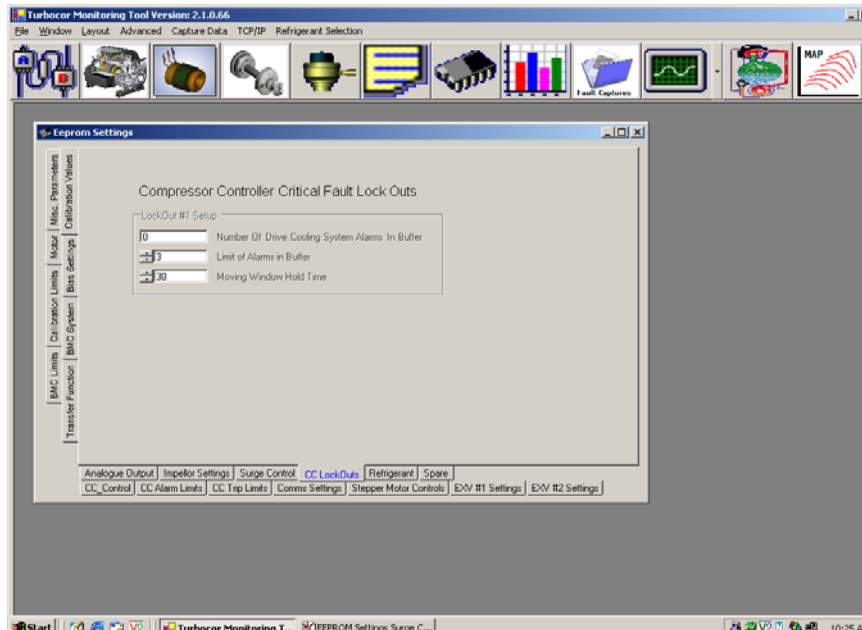

Figure 37 EEPROM Settings - CC Critical Fault Lock Outs

## 6.9.9 Refrigerant



TBD

## 6.10 Compressor Event Log

The compressor event log provides the user with details about the compressor events and faults.

To view the “Compressor Event Log” window, select “Window”→“Event Log” from the menu bar, or click on the “Event Log” icon located below the menu bar.

The “Type” column describes the type of event or fault logged:

- The  icon indicates that the compressor controller has started
- The  icon denotes information about the compressor events.
- The  icon denotes a compressor fault.

The “Time” column indicates the date and time at which the event or fault occurred, and the “Description” column provides details about the event or fault.

In the case of a compressor fault, check the timestamp of the fault. To help in troubleshooting the compressor fault, look at all the events and faults that occurred before the fault (i.e. events and faults logged with an earlier timestamp). Particularly, pay attention to the information logged immediately before the fault occurred, as it provides hints to the possible events that caused the fault.

To start downloading the compressor events, click on the “Start Download” button. The events with an index between the “Start Index” and the “Stop Index” will be downloaded. Click on the “Stop Download” button anytime to stop the download. The downloaded events may be saved to a file by clicking on the “Save Data to File” button. The “Current

Fault” parameter box indicates the current event being displayed.

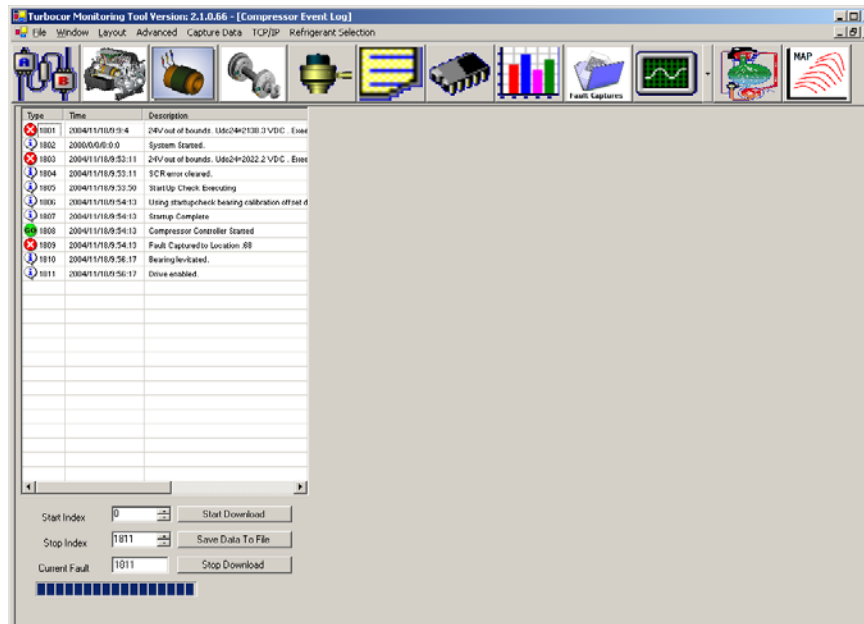

Figure 38 Event Log Window

## 6.11 History Data

The “Compressor History Data” window provides the user with information about the compressor energy usage.

To view the “Compressor History Data” window, select “Window”→ “Load Profile” from the menu bar, or click on the “Load Profile Graphs” icon located below the menu bar.

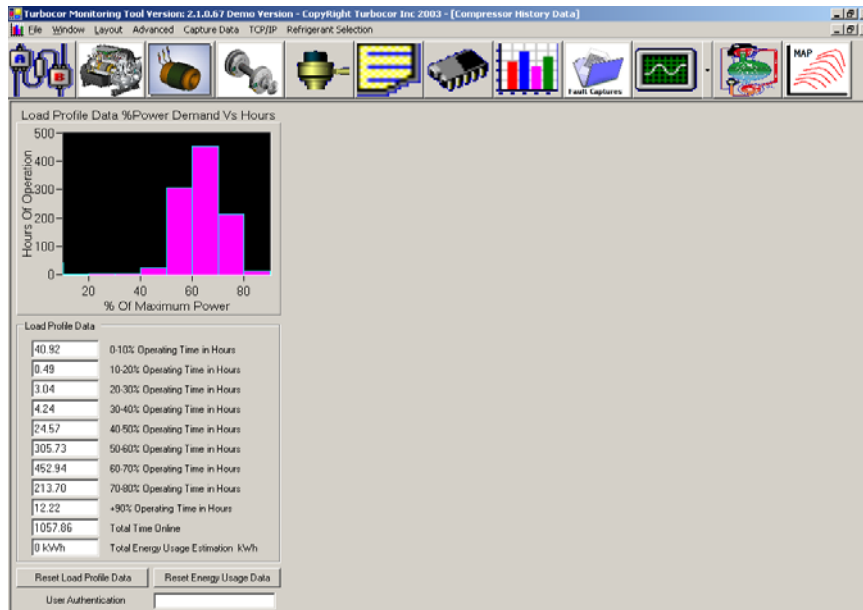

Figure 39 Compressor History Data

Table 20 Compressor History Data Parameters

Parameter	Description
Graph: %Power Demand vs. Hours	The graph shows the number of hours the compressor has been in operation for a given power demand. The statistical values of operating hours for each 10% of power demand is displayed in the “Load Profile Data” section.
Total Time Online	Total time the compressor has been running.
Total Energy Usage Estimation kWh	The estimated total energy used in an hour.
Reset Load Profile Data button	Reset the operating hours.
Reset Energy Usage Data button	Reset the energy usage counter.
User Authentication	Access code to use resets. The access code is the same as that used for the serial port connection, and must be a mid-level access code or higher.

## 6.12 Trending

### 6.12.1 Graphs

The trending graphs allow the user to view the individual “trends” of the parameters listed in Table 21 with respect to time. The time displayed is the PC system time, and is shown in HH:MM format.

To view the trending “Graphs”, as shown in Figure 40, click on the down arrow next to the “Trending” icon, and select “Charts 1”.

For each graph, the parameter plotted may be changed at any time by selecting a different parameter from the drop-

## Monitor Program Data and Controls

down menu. All graphs may be cleared simultaneously by clicking on “Reset Graphs” located on the menu bar.

When the “Graphs” window is closed, all parameters selected for graphing are automatically saved to a .csv data file, and may be viewed using a spreadsheet editor such as Microsoft® Excel. Each data file is limited by a maximum file size of 32,768 (2<sup>15</sup>) lines of data. The data file is named “TurboCor Service Monitoring Software#.csv”, where # is a unique file number automatically assigned. The data file is stored in the “\$TurboCor\_Install\_Dir\TurboCor Inc” directory (typically “C:\Program Files\TurboCor Inc”). Data files left in the “\$TurboCor\_Install\_Dir\TurboCor Inc” for more than 15 days are automatically deleted.

The parameters plotted may be played back by loading the stored data file. From the “File” menu, select “Open”. Go to the “\$TurboCor\_Install\_Dir\TurboCor Inc” directory, select the desired .csv data file to be loaded, and click on “Open”. The stored data begins to playback on the graphs. The playback speed may be adjusted from the “PlayBackSpeed” menu.

### NOTE:

The measurement unit (metric/imperial) displayed depends on the measurement unit previously set. To verify or change the measurement unit, refer to section 6.3 "Compressor Control" on page 23.

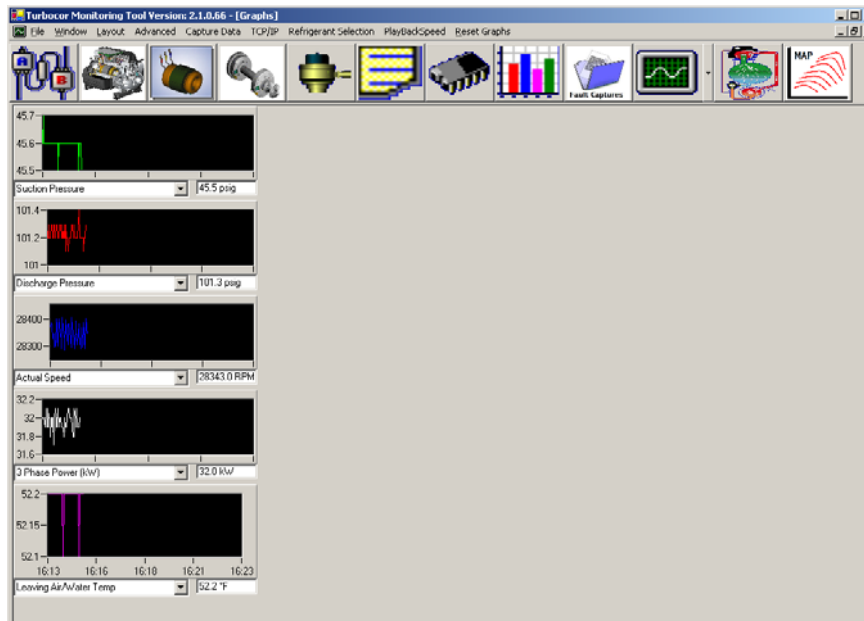

**Figure 40 Trending (Chart 1)**  
**Table 21 Trending Parameters**

Parameter	Description
3 Phase Voltage	3-phase AC input voltage (mains input)
3 Phase Amps	3-phase AC input current (mains input)
DC Bus Voltage	DC Bus Voltage as measured at the inverter
Compressor Demand	Requested motor power demand as a percentage of the maximum motor power [kW].
IGV Position	% of Inlet guide vane opening, 0.0% means the vanes are at 90° to the pipe line (Fully closed). 110% means 10° over turned from fully open.
Suction Pressure	The actual suction gauge pressure at the compressor flange as measured by the suction pressure transducer.

Table 21 Trending Parameters (Continued)

Parameter	Description
Discharge Pressure	The actual discharge gauge pressure at the compressor flange as measured by the discharge pressure transducer.
Suction Temperature	The actual suction temperature at the compressor flange as measured by the suction temperature/pressure transducer.
Discharge Temperature	The actual discharge temperature at the compressor flange as measured by the discharge temperature/pressure transducer.
Cavity Temperature	Temperature of the superheated gas moving past the shaft.
Entering Air/Water Temp	Temperature as measured from the 10K thermistor connected to the terminals marked "ENTRY" on the Compressor Interface module.
Leaving Air/Water Temp	Temperature as measured from the 10K thermistor connected to the terminals marked "LEAVE" on the Compressor Interface module.
24VDC Supply	Regulated 24V DC voltage as measured from the Backplane.
InterLock Status	Interlock status: either opened (denoted by 1.0) or closed (denoted by 0.0).
Surge Speed	Minimum compressor speed [RPM].
Choke Speed	Maximum compressor speed [RPM].
Stepper #1 PV	Controlled variable maintained by the stepper motor #1 output.
Stepper #1 Position	Ratio of the actual number of steps sent to the stepper motor over the maximum number of steps the motor is allowed to drive. Range: 0%-100%.
Stepper #2 PV	Controlled variable maintained by the stepper motor #2 output.
Stepper #2 Position	Ratio of the actual number of steps sent to the stepper motor over the maximum number of steps the motor is allowed to drive. Range: 0%-100%.
Cooling Solenoid Status	Cooling solenoid status: either open (denoted by 1.0) or closed (denoted by 0.0).
Axial Force	Current required to counteract axial unbalance force [Amps].
FX Force	Current required to counteract front x unbalance force [Amps].
FY Force	Current required to counteract front y unbalance force [Amps].
BX Force	Current required to counteract rear x unbalance force [Amps].
BY Force	Current required to counteract rear y unbalance force [Amps].
Actual Speed	Actual shaft speed in RPM.
Desired Speed	Commanding shaft speed in RPM (always higher than the actual shaft speed).
Motor Amps (Inverter Side)	Current output from the IGBT Inverter to the motor (torque-generating current component).
3 Phase Power (kW)	3-phase AC input power (mains input)
Inverter Temperature	Inverter temperature as measured by thermistor mounted under the IGBT Inverter.
Front Orbit Average	Percentile indicating the average front orbit displacement.

### 6.12.2 Trending & Data Acquisition

The “Trending & Data Acquisition” window allows the user to view and compare the trends of:

- Multiple temperature readings on one graph;
- Multiple energy demand and usage parameters on one graph
- Multiple compressor speed parameters on one graph

To view the “Trending & Data Acquisition” window, as shown in Figure 41, click on the down arrow next to the “Trending” icon, and select “Charts 2”.

For the “Temperatures” graph, the trends of the following parameters may be viewed simultaneously:

- Suction Temperature
- Discharge Temperature
- Liquid Temperature
- Entering Air/Water Temperature

- Leaving Air/Water Temperature
- Evaporating Temperature
- Condensing Temperature

For the “Energy Demand & Usage” graph, the trends of the following parameters may be viewed simultaneously:

- Actual (Mains) Power Input [kW]
- Requested (Motor) Power Input [kW]
- Compressor Demand %
- Inlet Guide Vane Opening %

For the “Compressor Speeds” graph, the trends of the following parameters may be viewed simultaneously:

- Actual Compressor Speed [RPM]
- Minimum Compressor Speed [RPM] (estimated surge)
- Maximum Compressor Speed [RPM] (choke)

For each parameter, check the checkbox next to the parameter to plot the parameter. Uncheck the checkbox to stop plotting the parameter. To clear the graphs, click on the “Clear Graphs” button.

To the right of the graphs, the compressor event log is displayed. However, the only events shown are those that occur after the “Trending & Data Acquisition” window is opened. To clear the event log, click on the “Clear Event Log” button.

Samples of the trends may also be saved to a log file. Select the time interval (from 10-1800 seconds) at which to capture the values. Click on the “Save” button to create the log file. The log file is saved in .csv format and may be viewed using a spreadsheet editor such as Microsoft® Excel. After creating the log file, the “Save” button becomes a “Stop” button. Click on the “Stop” button anytime to stop recording the trends to the log file. The trending log file records the date and time when the parameters are logged, and it records all parameters regardless if they are selected to be plotted or not. See Figure 42 for a sample trending log file.

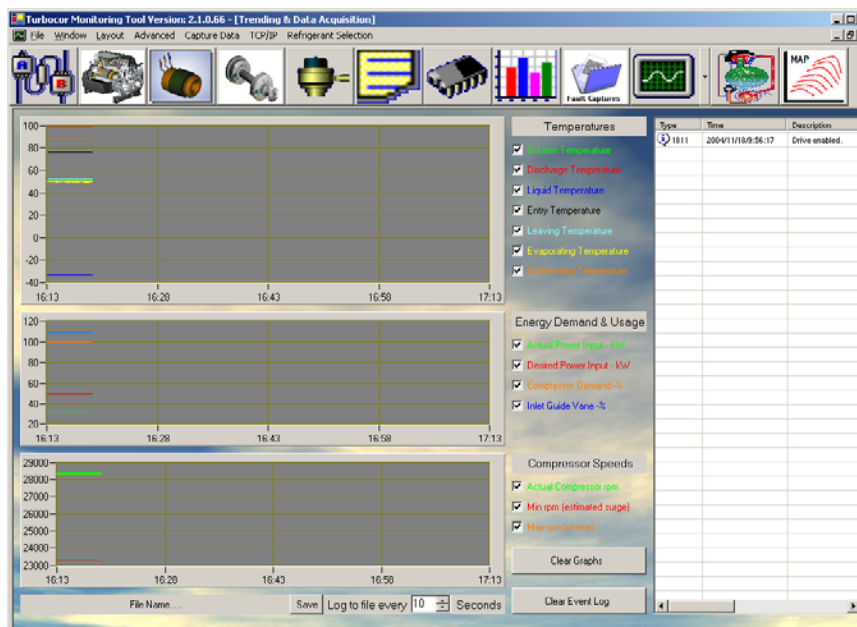

Figure 41 Trending (Chart 2)

	A	B	C	D	E	F	G	H	I	J	K	L	M	N	O
1	Time	Suction Temp	Discharge Temp	Liquid Tem	Entry Temp	Leaving Tem	SST	SCT	Power In	Desired Power	Demand%	Igv%	act Rpm	Surge	Choke
2	15:12:25	-186.7	-140.3	-163	-171.6	-179.8	11.4121	42.1892	53	52.8	78	110	32236	29952	34176
3	15:12:35	-183.2	-139.9	-163	-171.6	-179.7	11.3564	42.1869	52.5	53	78.3	110	32240	30208	34432
4	15:12:46	-187.2	-140.4	-163	-171.6	-179.8	11.4052	42.1161	52.9	52.4	77.7	110	32207	30077	34303
5	15:12:56	-184.3	-140.2	-163	-171.7	-179.8	11.4469	42.0629	52.6	52	77.3	110	32185	29952	34240
6	15:13:07	-186.6	-140.4	-163	-171.7	-179.8	11.4747	41.9847	52.6	51.7	77.1	110	32145	29951	34175
7	15:13:17	-187.5	-140.6	-163	-171.7	-179.7	11.4817	41.9634	52.7	52	77.5	110	32108	29823	34061

Figure 42 Trending Log

### 6.13 Compressor Map

The “Compressor Map” allows the user to view the operating envelope of the compressor, and to estimate its capacity and performance.

To view the “Compressor Map” window, select “Window” → “Performance Map” from the menu bar, or click on the “Compressor Envelope” icon located below the menu bar.

## Monitor Program Data and Controls

---

The graph, as shown in Figure 43, displays the saturated discharge temperature (SDT) versus the evaporator capacity. For a given evaporator capacity, the red lines mapped on the graph represents the constant compressor speed (in RPM) required to bring the saturated discharge temperature to the desired level. The mapping outline represents the compressor operational envelope, limited to the left by the minimum operational capacity, and to the right by the maximum operational capacity. The compressor cannot operate for load capacities outside the operational envelope. The blue dot on the compressor map represents the current operating point.

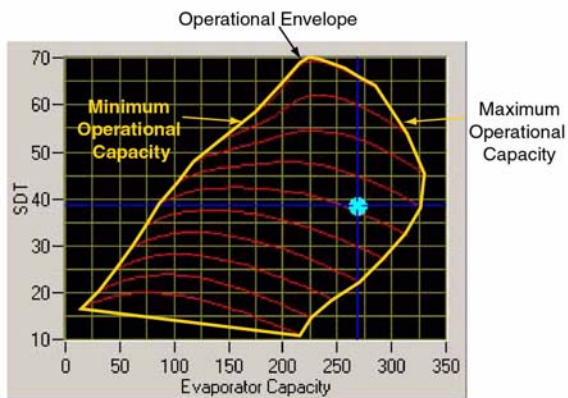

**Figure 43 Compressor Map**

The outputs section shows the estimated capacity and performance of the compressor, given the set of inputs. The

inputs are generated automatically when the serial port connection has been established (refer to 3.5 "Serial Port Connection" on page 6).

However, if the compressor is offline (i.e. the serial port connection has not been established), then it is possible to calculate the estimated compressor capacity and performance. To do so, input the following parameters in the input section:

- Suction pressure [kPa/Psi]
- Suction temperature [°C/°F]
- Discharge pressure [kPa/Psi]
- Mains (3-phase AC) power input [kW]
- Shaft speed [RPM]
- Subcooling temperature [°K/°R]

If the metric values (kPa, °C, °K) were inputted, set the "Check for Metric" checkbox. If imperial values (Psi, °F, °R) were inputted, ensure the checkbox is clear.

Click on the "Calculate" button. The graph and "outputs" section shows the estimated compressor capacity and performance.

### NOTE:

The measurement unit (metric/imperial) displayed depends on the measurement unit previously set. To verify or change the measurement unit, refer to section 6.3 "Compressor Control" on page 23.

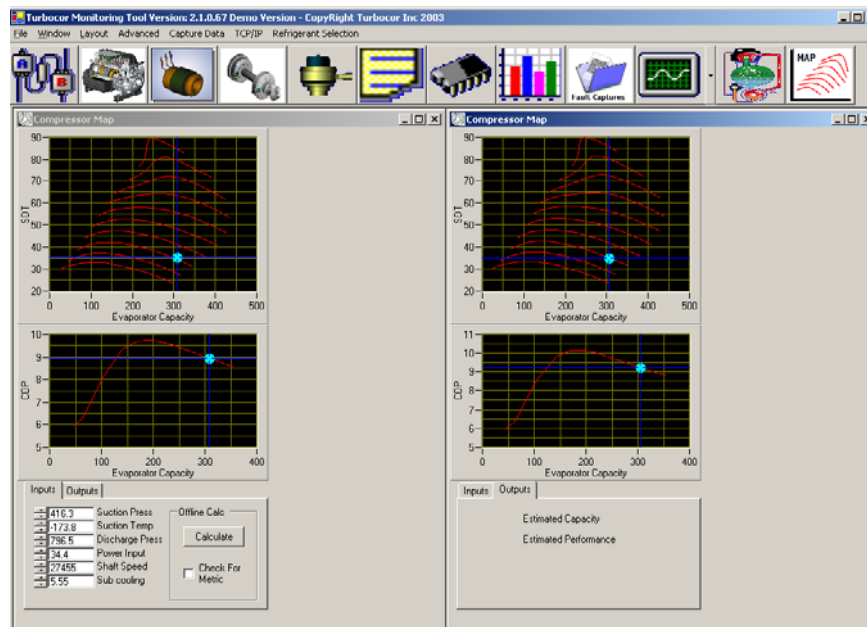

Figure 44 Compressor Map Window

## 6.14 Fault Captures

The “Fault Captures” window allows the user to view all the compressor faults, and the state of the compressor at the time the fault occurred.

To view the “Fault Captures” window, select “Window”→ “Fault Captures” from the menu bar, or click on the “Fault Captures” icon located below the menu bar.

Click on the “Download All Faults” button. A list of the most recent faults will be shown below the button.

The “Descriptive Fault Information” box shows the state of the compressor, under which the fault occurred, 10ms before the compressor shut down. The information can be used to determine the cause of the fault.

The “Current Index”, located above the “Descriptive Fault Information” box, is the index of the fault that occurred, for which the compressor state is being described.

The timestamp when the “Current Index” fault occurred is also shown above the “Descriptive Fault Information” box.

For a description of the fault that occurred, look under the descriptive fault information ID 47 to 51, where the motor, bearing, and compressor alarms and faults are described. See Figure 45.

To view the “Descriptive Fault Information” for another fault, change the current index. Select a number from 0 to the maximum index indicated - 1. Another option is to select one of the faults listed in the right-hand pane.

The “Descriptive Fault Information” may be saved by clicking on the “Save Fault Information” button. The data is saved to a .csv file, which may be viewed using a spreadsheet editor such as MS Excel.

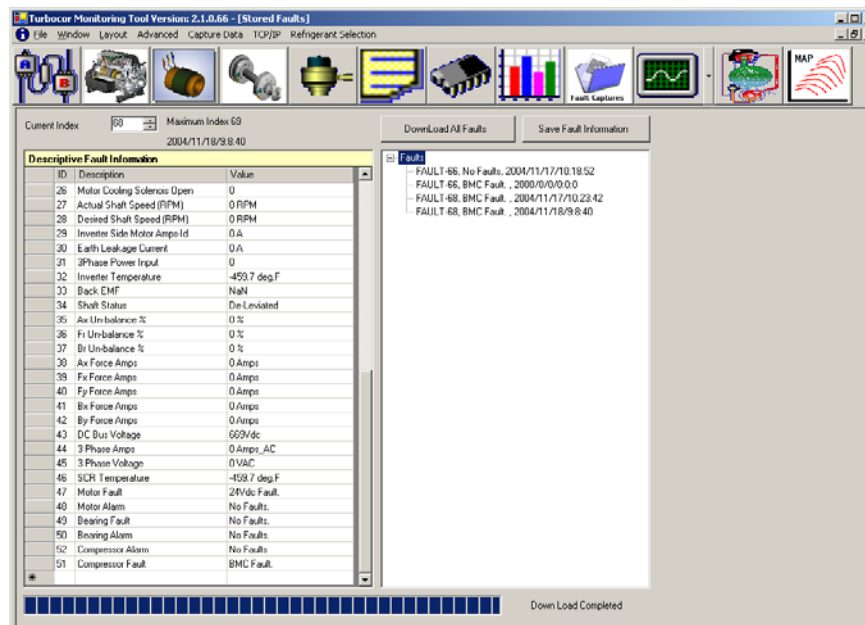

Figure 45 Stored Faults Window

## 6.15 Data Capture

The “Compressor Data Capture Screen” allows the user to view the compressor data, listed in Table 22, at a particular instant in time.

To capture the data, click on “Capture Data” from the menu bar. An “Acquiring Data” message box appears. After the “Acquiring Data” message box disappears, click on the “Data Preview” button to view the compressor data. The acquired data may be saved to file by clicking on the “Save Data to File” button.

### NOTE:

The measurement unit (metric/imperial) displayed depends on the measurement unit previously set. To verify or change the measurement unit, refer to section 6.3 “Compressor Control” on page 23.

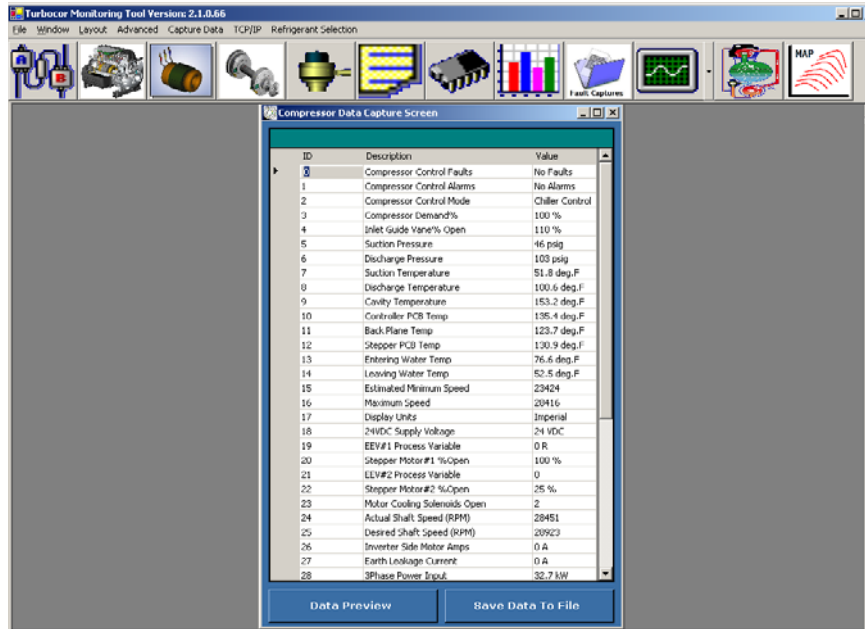

Figure 46 Compressor Data Capture Screen

**Table 22 List of Compressor Data Captured**

Data Parameter		Description
0	Compressor Control Faults	Displays the compressor's most recent active critical fault. Refer to 6.3.2 "Compressor Faults/Alarms" for further details.
1	Compressor Control Alarms	Displays the compressor's most recent active critical alarm. Refer to 6.3.2 "Compressor Faults/Alarms" for further details.
2	Compressor Control Mode	Selects the source of demand for the compressor: either Calibration, Manual Control, Analog Input, Modbus Network, or Chiller Control. Refer to 6.3.1 "Compressor Control Modes" for further details.
3	Compressor Demand %	Requested motor power demand as a percentage of the maximum motor power [kW].
4	Inlet Guide Vane % Open	% of Inlet guide vane opening, 0.0% means the vanes are at 90° to the pipe line (Fully closed). 110% means 10° over turned from fully open.
5	Suction Pressure	The actual suction gauge pressure at the compressor flange as measured by the suction pressure transducer.
6	Discharge Pressure	The actual discharge gauge pressure at the compressor flange as measured by the discharge pressure transducer.
7	Suction Temperature	The actual suction temperature at the compressor flange as measured by the suction temperature/pressure transducer.
8	Discharge Temperature	The actual discharge temperature at the compressor flange as measured by the discharge temperature/pressure transducer.
9	Cavity Temperature	Temperature of the superheated gas moving past the shaft.
10	Controller PCB Temperature	Temperature of the BMCC board.
11	Backplane Temperature	Temperature of the Backplane.
12	Stepper PCB Temperature	Temperature of the Serial Driver.
13	Entering Water Temperature	Temperature as measured from the 10K thermistor connected to the terminals marked "ENTRY" on the Compressor Interface module.
14	Leaving Water Temperature	Temperature as measured from the 10K thermistor connected to the terminals marked "LEAVE" on the Compressor Interface module.
15	Estimated Minimum Speed (compressor speed in RPM)	Estimated minimum RPM the compressor can run at with a fully open inlet guide vane.
16	Maximum Speed (compressor speed in RPM)	Maximum RPM the compressor can run at for a given set of inlet and outlet conditions.
17	Display Units	Metric / Imperial units displayed.
18	24VDC supply voltage	Voltage outputted by 24VDC voltage supply.
19	EEV#1 Process Variable	Controlled variable maintained by the stepper motor #1 output.
20	Stepper Motor #1 % Open	Ratio of the actual number of steps sent to the stepper motor over the maximum number of steps the motor is allowed to drive. Range: 0%-100%.
21	EEV#2 Process Variable	Controlled variable maintained by the stepper motor #2 output.
22	Stepper Motor #2 % Open	Ratio of the actual number of steps sent to the stepper motor over the maximum number of steps the motor is allowed to drive. Range: 0%-100%.
23	Motor-Cooling Solenoids Open	Number of motor-cooling solenoids open.

**Table 22 List of Compressor Data Captured (Continued)**

Data Parameter		Description
24	Actual Shaft Speed (RPM)	Actual rotational shaft speed.
25	Desired Shaft Speed (RPM)	Desired rotational shaft speed.
26	Inverter Side Motor Amps	Current outputted from the IGBT Inverter to the motor (torque-generating current component).
27	Earth Leakage Current	Motor current that leaks to ground due to an insulation fault.
28	3-Phase Power Input	Mains (AC) input power [kW].
29	Inverter Temperature	Inverter temperature as measured by thermistor mounted under the IGBT Inverter.
30	Back EMF	Internal motor voltage
31	Shaft Status	Shaft state. Either levitated or de-levitated.
32	Ax Un-balance %	Percentage unbalance of total allowable axial displacement.
33	Fr Un-balance %	Percentage unbalance of total allowable front radial displacement.
34	Br Un-balance %	Percentage unbalance of total allowable rear radial displacement.
35	Ax Force [Amps]	Current required to counteract axial unbalance force.
36	Fx Force [Amps]	Current required to counteract front x unbalance force.
37	Fy Force [Amps]	Current required to counteract front y unbalance force.
38	Bx Force [Amps]	Current required to counteract rear x unbalance force.
39	By Force [Amps]	Current required to counteract rear y unbalance force.
40	3 Phase Amps	Mains (AC) input current.
41	3 Phase Voltage	Mains (AC) input voltage.
42	Compressor Real Time Clock	Time of data capture.

## Appendix A: Determination of Actual Power Setting

The BMC\CC holds four variables in the EPROM that determine the input power capability of the compressor based on the model number of the compressor. These four variables define the straight-line equation for the maximum referred power ( $y=mx+c$ ) as a function of total flange to flange pressure ratio, see graph below. The referred power is the power absorbed at the reference pressure and temperature.

Next the power-reset factor may be calculated from the absolute suction pressure (referred power).

To obtain the actual maximum power input, the referred power input is multiplied by the power reset factor

The next step is to calculate the percentage of the maximum power that is required based on the analogue input voltage level, modbus set demand or chiller control supplied demand.

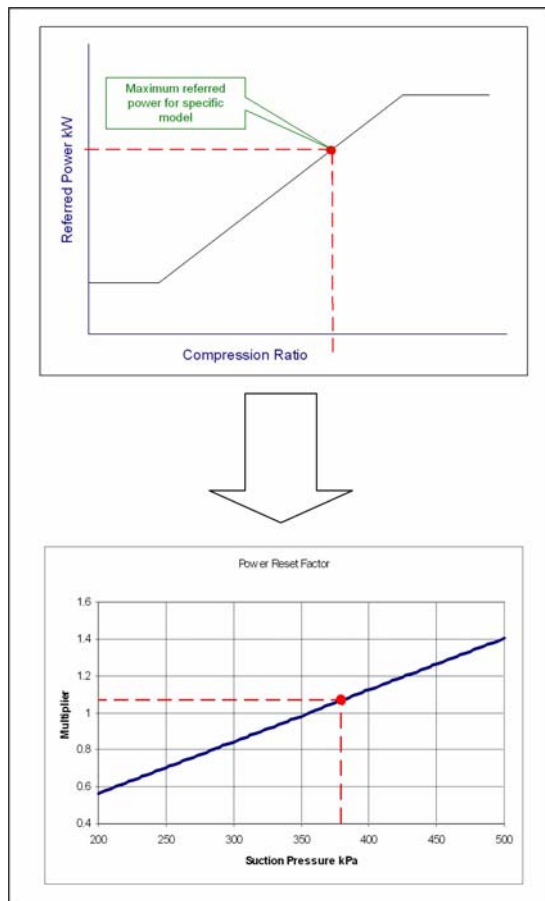

### Analog Input Mode Example:

Calculate the actual 3ph power set point for a 75ton (TT300W-75TR-460-480V) compressor running with a suction pressure of 340 kPa, a compression ratio of 2.80 and an input voltage level of 6.50 VDC.

Recall that for analogue input mode, the input voltage range is 0-10VDC, with a deadband of 2VDC.

Thus, the demand % for a 6.50 VDC input is:

$$\%demand = (6.5-2)/(10-2) = 0.562 \text{ or } 56.2\%$$

*For a reference pressure of 356kPa at 283°K:*

The referred power is determined to be:

$$PWR_{ref} = 24.783 * 2.80 - 14.06 = 55.32 \text{ kW}$$

The actual maximum power is:

$$PWR_{max} = 55.32 * (340 / 356) = 52.83 \text{ kW}$$

The desired 3 phase power input is then :

$$\text{Desired power} = 52.83 * .562 = 29.69 \text{ kW}$$

### ModBus Network Input Mode Example:

Calculate the actual 3ph power set point for a 75ton (TT300W-75TR-460-480V) compressor running with a suction pressure of 340 kPa, a compression ratio of 2.80 and an input voltage level of 6.50 VDC.

The demand % for a 6.50 VDC input is:

Recall that in Modbus network input mode, the demand is manually set through the Monitor program.

In this case, the demand is set to 56.2%.

---

*For a reference pressure of 356kPa at 283°K:*

The referred power is determined to be:

$$PWR_{ref} = 24.783 * 2.80 - 14.06 = 55.32 \text{ kW}$$

The actual maximum power is:

$$PWR_{max} = 55.32 * (340 / 356) = 52.83 \text{ kW}$$

The desired 3 phase power input is then :

$$\text{Desired power} = 52.83 * .562 = 29.69 \text{ kW}$$



Danfoss Turbocor Compressors Inc., 1850 Trans-Canada Highway, Dorval, Quebec H9P 2N4  
Phone: 888-440-0523 Fax: 514-421-4277 [www.turbocor.com](http://www.turbocor.com)