



**TWIN-TURBINE CENTRIFUGAL
COMPRESSOR
MODEL TT300/TT400 (R134a)**



APPLICATION MANUAL

Proprietary Notice

This publication contains information proprietary and confidential to Danfoss Turbocor Compressors Inc. Any reproduction, disclosure or unauthorized use of this publication is expressly prohibited without written approval from Danfoss Turbocor.

Danfoss Turbocor reserves the right to make changes without notice in product or component design as warranted by evolution in user needs or advancements in engineering or manufacturing technology.

Danfoss Turbocor has exercised its best efforts to ensure that the information contained in this manual is correct. However, no warranty of reliability or accuracy is given with respect to the information and Danfoss Turbocor shall not be responsible or liable for the correctness or suitability of the information or for any error or omission. If you encounter any difficulty in using this manual, please forward your query to Danfoss Turbocor or its authorized sales agent.

All brand names and product names used in this manual are trademarks, registered trademarks, or trade names of their respective holders.

For product support issues, corrections, or enquiries, contact:

Product Support
product.support@turbocor.com

Danfoss Turbocor Compressors Inc.
1850 Trans-Canada
Dorval, Quebec
Canada H9P 2N4
Tel. (514) 421-0523
Tel. (888) 440-0523
Fax (514) 421-6490
www.turbocor.com

List of Acronyms

CE	Conformance European
CSA	Canadian Standards Association
EMC	electromagnetic compatibility
EMI	electromagnetic interference
ETL	ETL Testing Laboratories, now a mark of Intertek Testing Services
EXV	electronic expansion valve
FLA	full load current
IEEE	Institute of Electrical and Electronic Engineers
IGBT	insulated gate bipolar transistor
IGV	inlet guide vane
LBV	load balance valve
LLS	liquid line solenoid
LRA	locked rotor current
NTC	negative temperature coefficient
PWM	pulse width modulation
TXV	thermal expansion valve
UL	Underwriters Laboratories
VFD	variable frequency drive

Contents



Introduction	1
Product Certification	1
General Specifications	1
Construction	1
Refrigerant Type	1
Environment	1
Noise	1
Accessories	1
Line Reactor Kit	2
Service Valve, Non-return Valve, and Flange Kits	2
Suction Strainer Kit (TT300 only)	2
Compressor Mounting Kit	2
EMI/EMC Filter (non-CE version)	2
EMI/EMC Filter (CE version)	2
Harmonic Filter	2
Operating Range	3
Minimum Unloading Capacity	5
Control Logic Guidelines For Multiple Compressors	7
Parallel Control	7
Staged Control	7
Electrical Specification	8
Supply Voltage and Frequency	8
Disconnects	8
AC Input Line Protection	9
Power Line Contactor	9
CE Compliance and EMI/EMC Filtering	9
Surge Protection	9
Harmonic Filtering (IEEE 519)	9
Earth Connections	10
Equipment Panel	11
Mains Input Cable Specification	11
Control Interface Wiring	14
Control Wiring Connection Guidelines	15
Interface Cable	15
Compressor Interface Module Mounting Details	16
Piping Considerations	17
Environmental Considerations	18
Humidity	18
Vibration	18
Shipping Considerations	18
Vibration	18
Water Temperature Thermistor Specification	19
Combined Temperature/Pressure Thermistor Specification	21
Appendix A: Danfoss Turbocor Product Ordering Guide	
Model Nomenclature	23
TT300 Compressors:	23
TT400 Compressors:	24
TT300 Accessories:	25
TT400 Accessories:	25

Appendix B: Physical Data	
Mounting Base	27
Clearance	27
Valve Flanges	27
Piping Expanders	27
Appendix C: TT300 and TT400 Centrifugal Compressor Guide Specification	
General	35
Refrigerant	35
Compressor Bearings	35
Capacity Control	35
Compressor Motor	35
Compressor Electronics	36
Ancillary Devices	36
Appendix D: System Design Guidelines (R134a)	
General Requirements	37
Electrical Requirements	38
Control Requirements	38
Application-specific Requirements	39
Medium Evaporating Temperature Application	39
Air-Cooled Units	39
Multiple Compressors on Common Circuit Using One Evaporator and One Condenser	39
Packaged Air-side With D-X Type Evaporator and Multiple Evaporator Coils	40
Sample Refrigeration Circuits	40
Appendix E: Accessory Specifications	
Suction Service Valve (TT300)	49
Suction Flange (TT400)	51
Discharge Service/Non-return Valve (TT300)	52
Discharge Flange	54
Discharge Flange (TT400)	55
Discharge Flange/Non-return Valve (TT300)	56
Suction Flange	58
Economizer Service Valve (TT300)	59
Economizer Flange	60
Line Reactor 140A (10% impedance, TT300 only)	61
Line Reactor 140A (5% impedance, TT300 only)	63
Line Reactor 180A (10% impedance)	65
Line Reactor 180A (5% impedance)	67
Suction Strainer (TT300)	69
EMI/EMC Filter (UL)	70
EMI/EMC Filter (CE)	72
Harmonic Filter (TT300)	74
Appendix F: Compressor Specifications	
TT300 Sound Power Measurements	77
TT400 Sound Power Measurements	79

Introduction

This manual is intended as a reference for application engineers, consultants, sales personnel, and HVAC designers.

Product Certification

The TT300 compressor is ETL  and CE  listed and has been tested in accordance with UL standard 984 and CSA standard C22.2.

General Specifications

The maximum designed high-side pressure is 278 psig (1917 kPa).

Construction

- **Compressor** - Semi-hermetic design
- **Main Housing** - Dimensionally-stabilized aluminum
- **Covers** - High-impact, UV stabilized, flame-resistant polymer
- **Shaft** - High-strength alloy
- **Impellers** - High-strength aluminum
- **Motor** - Permanent magnet, synchronous
- **Bearings** - Integrated, digitally-controlled, magnetic
- **Compressor Control** - Integrated, digital capacity control
- **Enclosure** - IP54 rating as per UL 984 requirement

Environment

The compressor should be stored and operated within the following ambient temperature ranges:

- storage: -30°C to 50°C (14°F to 122°F)
- operation: -1°C to 50°C (30°F to 122°F).

NOTE:

Contact Danfoss Turbocor for lower ambient temperature operations.

NOTE:

Refer to “Operating Range” on page 3 for details of the operating conditions.

Noise

Refer to Appendix F for sound power measurements of the TT300 and TT400 compressors

Refrigerant Type

The TT compressor is totally oil-free and optimized for use with refrigerant HFC-134a. Do not use recycled refrigerant as it may contain oil, which can affect system performance. The refrigerant should be pure and stored in virgin containers.

Accessories

Refer to Appendix E for product specifications pertaining to the accessories described in this section.

Line Reactor Kit

The line reactor acts like an input buffer between the motor drive power circuits and the AC line power. Line reactors provide additional circuit impedance that improves power factor, reduces line current harmonics and dampens the transient voltages on the power line thereby protecting the electronic motor drive components.

NOTE:

Failure to install a line reactor will result in a higher than rated current draw, larger cabling requirements, and lower power factor.

Service Valve, Non-return Valve, and Flange Kits

Danfoss Turbocor offers a variety of valve and flange kits for the TT300 compressor to suit most application requirements. For the TT400 compressor, Danfoss Turbocor offers flange kits only.

Service valves isolate the refrigerant from the compressor when it is necessary to remove the compressor for servicing.

Non-return valves prevent reverse flow of refrigerant into the discharge port during compressor shutdown.

IMPORTANT: Reverse flow of refrigerant into the compressor discharge port can cause damage to compressor components. The non-return valve does not provide a positive seal, and therefore certain applications may also require the installation of a check valve.

NOTE:

If Danfoss Turbocor valves and flanges are not used, refer to the flange specifications in Appendix B.

Suction Service Valve Kit (TT300 only)

The suction service valve is a 3-1/8 inch ball valve installed at the compressor inlet port.

Discharge Service/Non-return Valve Kit (TT300 only)

The discharge service valve is a 2-1/8 inch ball valve with integral non-return valve installed at the compressor outlet port.

Discharge Non-return Flange Kit (TT300 only)

Flange kit part includes an integral non-return valve.

Economizer Service Valve Kit (TT300 only)

The economizer service valve, if fitted, is a 7/8-inch ball valve installed at the compressor interstage port.

Flange Kits

3-1/8-inch, 2-1/8-inch and 7/8-inch flange kits are available for connection to the suction, discharge, and economizer compressor ports, respectively. The flanges are suitable for brazed copper pipe connections.

Suction Strainer Kit (TT300 only)

The suction strainer prevents foreign particles from entering the compressor. It should be located as close as possible to the suction port of the compressor.

NOTE:

Warranty is void if components returned to Danfoss Turbocor contain foreign particles.

Compressor Mounting Kit

The mounting kit consists of four rubber mounts that support the compressor base rails. They are designed to minimize the transfer of vibration from the compressor's supporting structure to the compressor.

EMI/EMC Filter (non-CE version)

This filter minimizes harmonics in the higher frequency domain (typically above 1kHz). It should be located between the disconnect switch and the line reactor.

EMI/EMC Filter (CE version)

In order for the compressor to be CE compliant, this EMI/EMC filtering device must be connected between the disconnect switch and the line reactor.

Harmonic Filter

The harmonic filter operates in conjunction with the line reactor to minimize low-frequency harmonics on the power line emanating from the switching devices on the compressor. It is required for IEEE 519 compliance and should be connected between the line reactor and the compressor, in parallel with the compressor.

Operating Range

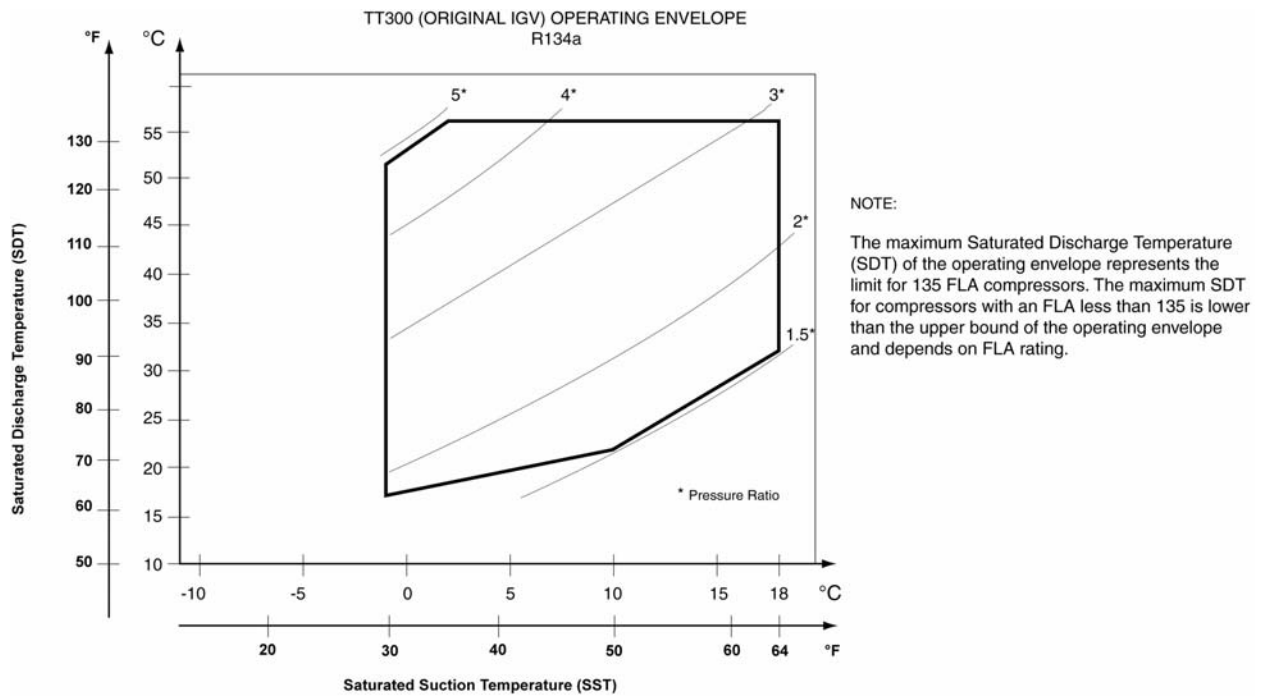

Figure 1 TT300 Operating Envelope (Original IGV)

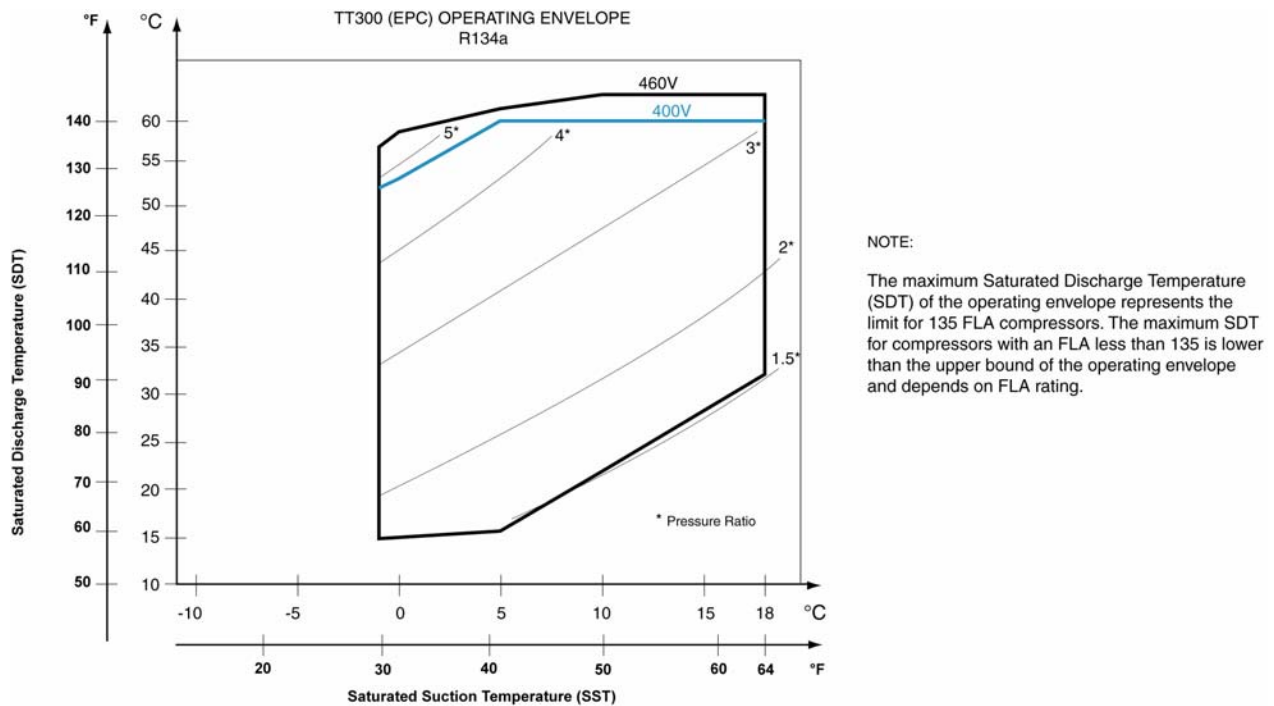

Figure 2 TT300 Operating Envelope (Extended Performance Compressor)

Operating Range

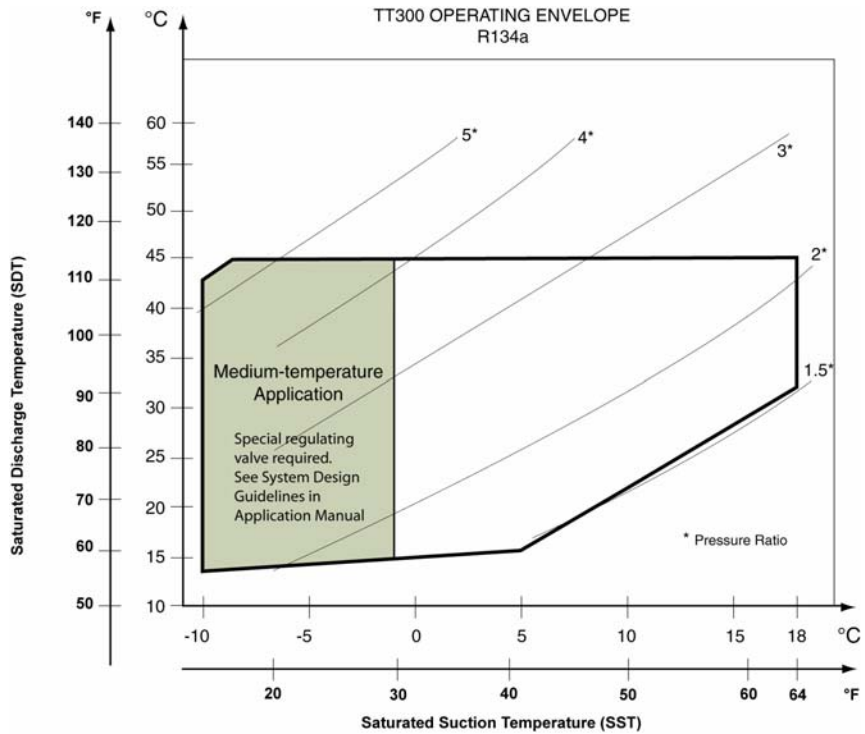

Figure 3 TT300 Operating Envelope (Medium-Temperature Compressor)

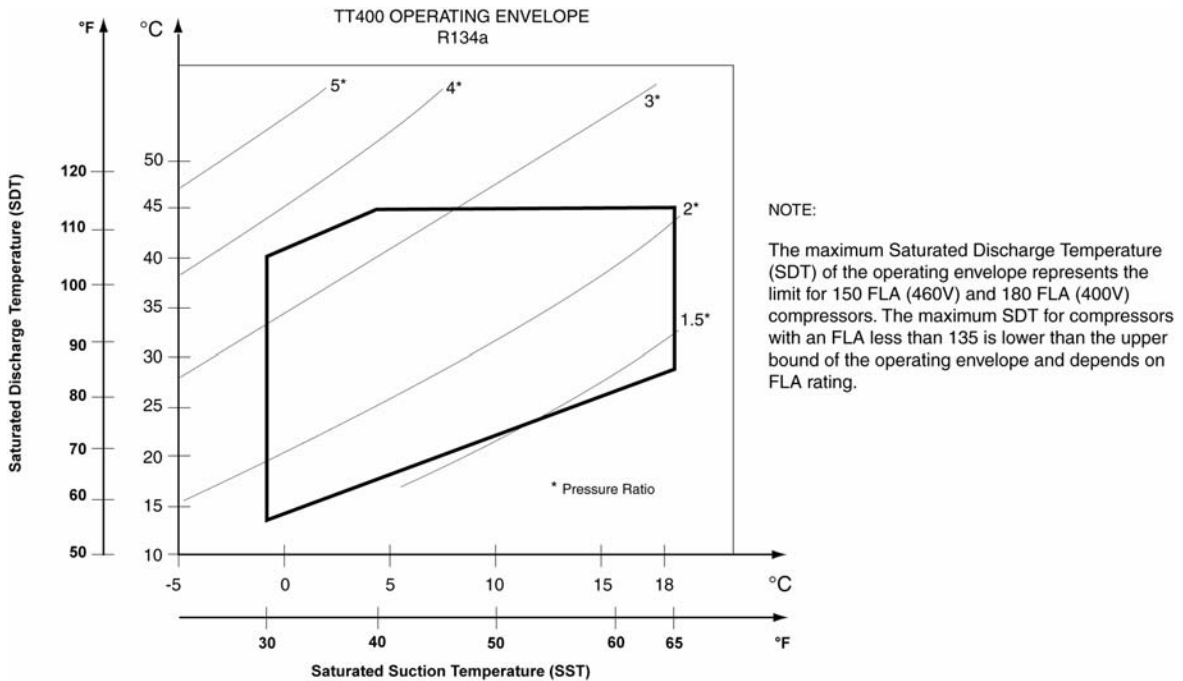

Figure 4 TT400 Operating Envelope

Minimum Unloading Capacity

Due to the centrifugal compression nature of the Turbocor compressors, the minimum unloading capacity depends on the operating pressure ratio. The lower the pressure ratio, the lower the minimum unloading capability. For a quick and easy reference, the following graphs have been created to determine the minimum unloading capacity versus the saturated discharge temperature (SDT) for given saturated

suction temperatures (SST). The following graphs are intended as a guide that should be considered in the system design. Refer to the relevant selection program for more accurate values.

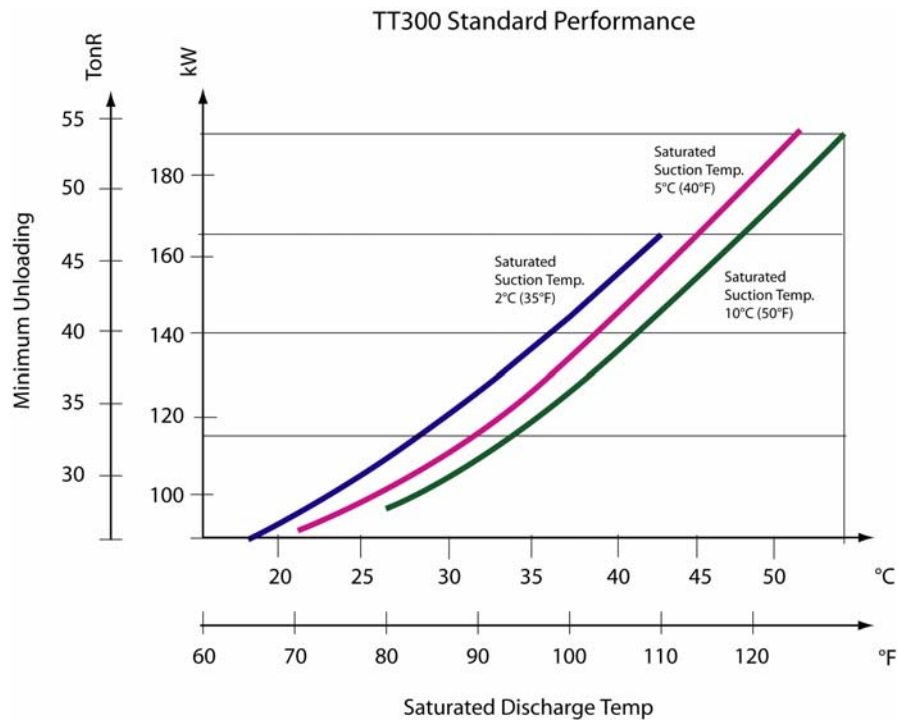

Figure 5 TT300 Compressor, Minimum Unloading Capacity (original IGV)

Minimum Unloading Capacity

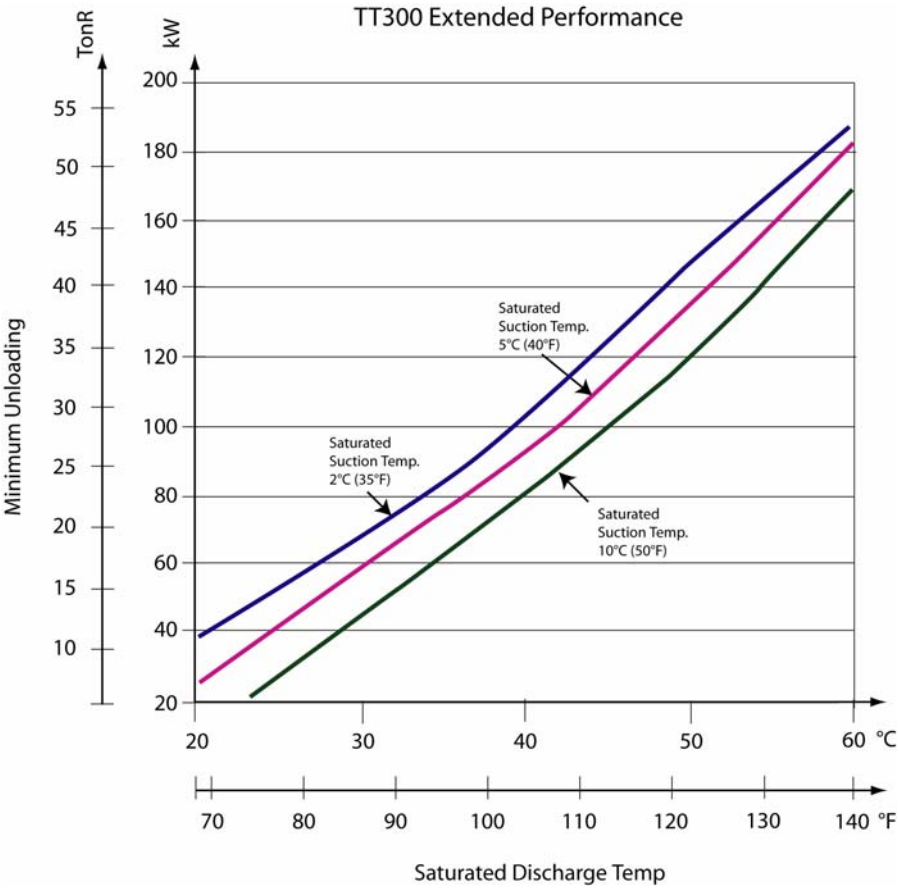

Figure 6 TT300 Compressor, Minimum Unloading Capacity (extended performance compressor)

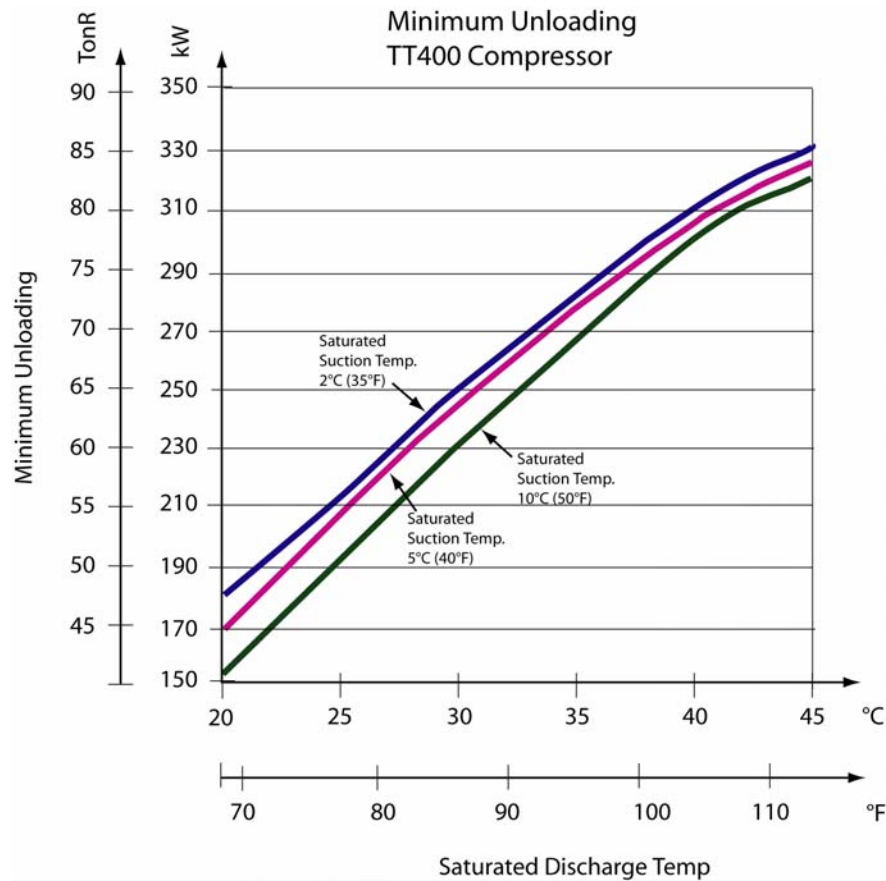

Figure 7 TT400 Compressor, Minimum Unloading Capacity

Control Logic Guidelines For Multiple Compressors

Due to the nature of centrifugal compression, special control logic must be implemented for proper staging of multiple Turbocor compressors when installed on a common circuit. This section is intended as only guide without going into details. Control details are specific to each OEM's individual control strategy.

The Turbocor centrifugal compressors can be controlled in two ways: parallel control and staged control.

Parallel Control

This method of control provides smoother and more efficient system operation. However, there needs to be enough minimum load to keep all compressors on line for extended period without going into surge.

The external controller provides identical demand for all the compressors as load varies and cycles off the lag compressors when load is less than the minimum unloading. To bring these compressors back on line, de-energize the running compressors and re-start all using the same demand signal.

Staged Control

Compressors can be staged one by one depending on the demand. Using this approach to compressor control, the lead compressor starts and loads up to approximately close to its full capacity before the next compressor is brought on line. Prior to energizing any lag compressor, the lead compressor should run in a stable condition for a few minutes, and demand checked to see if there is still enough load to justify running another compressor. The load must

Electrical Specification

be high enough insuring that the compressor(s) on line plus the compressor being added would not operate in surge.

If additional compressors need to be brought on line after going through the above process, then the operating compressor(s) must be unloaded (slowed down) to decrease the discharge pressure and increase the suction pressure. Continue to reduce the pressure ratio to less than 2.5, then start the next compressor. Operate all energized compressors in parallel as described above (load them equally so all running compressors can pass through surge boundaries).

A compressor should be cycled off when insufficient load causes the operating compressor(s) to go into surge, then the remaining operating compressors can speed up to meet the demand.

To improve operating efficiency during part loads in a multiple compressor system, maximize the number of compressors in operation without allowing them to go into surge.

During the lag compressor staging, if the operating compressors can not be unloaded down to less than 2.5 pressure ratio before starting the lag compressor, then Load Balancing valve needs to be activated. We recommend installing Load Balancing Valve upstream of the non-return valve to help the lag compressor at the start up.

However, if the pressure ratio still stays higher than 2.5 the operating compressor(s) may need to be cycled off and then started them and the lag in parallel .

NOTE:

These control guidelines are specifically written for single circuited (multiple compressors on a common refrigerant circuit) applications. Individually circuited applications have similar staging requirements. However, the ramping down before adding additional compressors is not required.

NOTE:

Pressure Ratio is the ratio of absolute discharge to absolute suction pressures.

Electrical Specification

Supply Voltage and Frequency

Turbocor compressors are designed to operate with a power supply that is within an acceptable tolerance for each nominally rated voltage and frequency. The tables below specifies the acceptable supply voltage and frequency ranges. Using a supply voltage/frequency at or beyond the range limit will cause the compressor to shut down.

Nominal Voltage	Acceptable Voltage Range
400V (50Hz)	400V \pm 10% (360V - 440V)
460V (60Hz)	460V \pm 10% (414V - 506V)
575V (60Hz)	575V \pm 10% (518V - 633V)

Nominal Frequency	Acceptable Frequency Range
50Hz	50Hz \pm 5% (47Hz - 53Hz)
60Hz	60Hz \pm 5% (57Hz - 63Hz)

Disconnects

An input disconnect (for example, a switch or circuit breaker) must be installed in the line before the compressor in accordance with applicable local, national, and international codes (e.g., NEC/CEC). Size the disconnect according to the full-load current.

WARNING

The full-load current rating is based on insertion of a line reactor in the power line; refer to Appendix E for specifications. Failure to use a line reactor will result in poor power factor and higher full-load current.

Refer to Figure 8 for interconnection details.

AC Input Line Protection

WARNING

Most codes require that upstream branch protection be provided to protect input power wiring. To guard against personal injury and/or equipment damage caused by improper line fusing, use only properly rated, fast-acting fuses. Branch circuit breakers or disconnect switches cannot provide this level of protection for compressor components.

User-supplied branch circuit protection fuses must be installed according to the applicable local, national, and international codes (e.g., NEC/CEC). The fuses must be installed in the line before the compressor AC input terminals.

Power Line Contactor

The power line contactor is optional. Consult local codes to determine if a power line contactor is necessary for your application.

CE Compliance and EMI/EMC Filtering

Although the TT300 and TT400 compressors are CE listed, the compliance of the compressor with the EMC directive depends on the use of the CE EMI/EMC filter provided by Danfoss Turbocor; refer to Figure 8 and to TPS-00021 in Appendix E for further details. If for some reason or due to the nature of your application and or installation, the use of this component is not possible, an alternative component with the same attenuation characteristics must be used to maintain compliance with the EMC Directive. It is the responsibility of the user to maintain compliance with the Directives. Contact a Danfoss Turbocor sales engineer for further details.

To strictly address EMI/EMC problems, Danfoss Turbocor recommends the installation of UL-approved EMI/EMC

filter device on the input power line; refer to TPS-00020 in Appendix E for further details.

Proper installation of the EMI/EMC filter can have a dramatic effect on overall performance. Although the filter reduces electrical noise on the power lines (conducted emissions), it should be located as close as possible to the compressor to reduce broadcasting of the noise (radiated emissions) from the power lines themselves. The capacitors within the filter short the noise to ground, so it is imperative that the filter maintains a good ground. A short, heavy, stranded conductor from the filter chassis to the main ground bus is recommended for top performance. A battery braid, litz wire, or flexible welding cable with many fine strands is recommended for best grounding performance. The multiple strand cabling provides more surface area in order to conduct the high frequencies that are on the grounding cable.

Radiation of noise is also a concern for power line routing, as it can effectively bypass the filter. Input and output filter leads should be separated by a maximum practical distance within enclosures and should be routed separately in interconnecting conduits when used.

Surge Protection

The TT300 and TT400 compressors have been tested in accordance with IEC Standard 1000-4-4. Electrical Fast Transient/Burst Requirement, section 6.1.1 and figures 2 and 3.

For additional protection, a surge suppressor can be installed between the line reactor and the compressor.

Harmonic Filtering (IEEE 519)

Danfoss Turbocor recommends the installation of a harmonic filter device between the line reactor and the compressor in order to comply with IEEE 519 requirements, as shown in Figure 8.

Electrical Specification

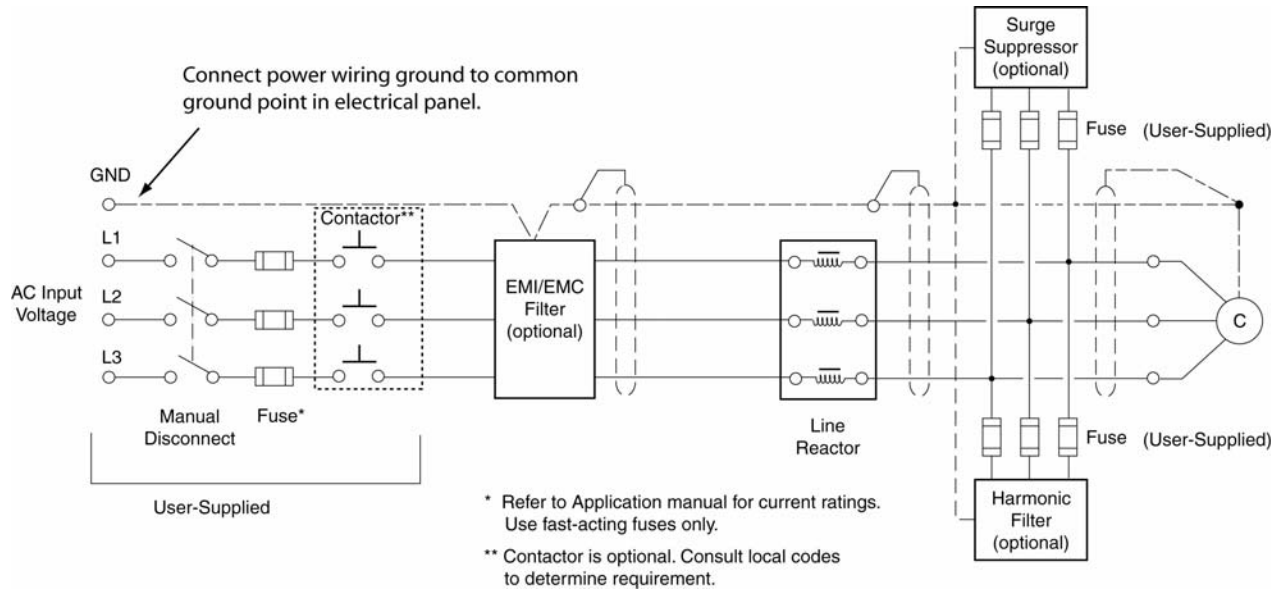

Figure 8 Typical Electrical Connections

Earth Connections

Grounding Guidelines

1. All metal parts should be connected to ground, including the shields of electrical cables.
2. Verify continuity of all ground connections.
3. Ensure solid ground connections (both mechanical and electrical).

At one point, usually the entrance of the power supply panel, all grounds should be connected together; refer to “Equipment Panel” on page 11.

From an EMC standpoint it is best to categorize different types of grounds and treat them independently:

- Safety ground (PE) and shields of mains cables
- Analog grounds, shielding of interface cables
- Digital grounds
- Reference ground (panel doors, backplate, etc.)

Refer to Figure 9.

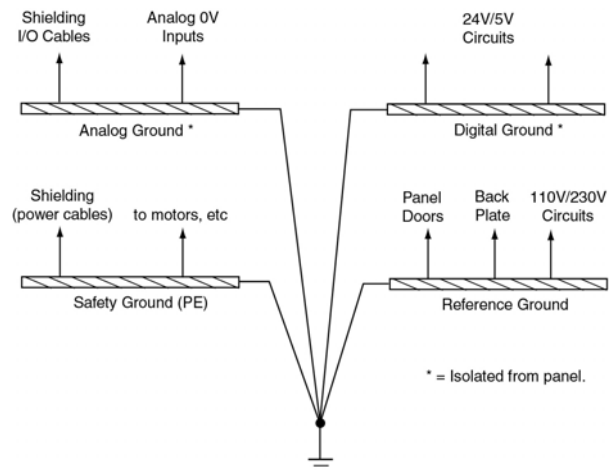

Figure 9 Typical Ground Connections

Equipment Panel

Normally, the line reactor, EMI/EMC filter(s), and the harmonic filter will be installed in a panel. This could be the same panel where the controls are located. When designing a panel, attention should be given to the following recommendations:

- All metal parts should be properly connected to insure an electrical connection. Connect panel doors with braided cable.
- Separate panel into sections for power, and interface/control functions.
- Keep power cables and interface cables separate. Use metal cable glands for shielded cables.
- In case of a wire-loom going to the panel door, shield it using a metal-braided hose that is connected to ground at both ends.
- Electrical panel must have a dedicated ground conductor as per relevant electrical codes. See Figure 10.
- Verify that the panel ground conductor is sized in accordance with relevant electrical codes.

NOTE:

The installing electrical contractor is responsible for connecting the panel ground to the facility ground in accordance with relevant electrical codes and standards such as NEC section 250 in the US or equivalent for other countries.

Mains Input Cable Specification

The aim of electrical cables is to be a carrier (conductor) for electrical power. The influence of the power source on the environment, or the influence of the environment on the power source, should be such that neither the proper functioning of the compressor nor equipment in its environment is adversely affected. Therefore, Danfoss Turbocor advises to use some type of shielded cable for the mains input.

When using shielded cable, select a cable with an effective shield. A cable with an aluminum foil will be far less effective than a specially designed conductive braid. It is best to connect both ends of the cable shield to ground, since the shield is not part of the signal path.

The mains input cable should be CSA, UL, or CE approved, 3-wire with a common shield and single ground. The cable must be rated for 90° C (194 °F) minimum and maximum current according to the applicable model; refer to Table 1. It is recommended that the cable be double-jacketed, i.e., teck cable type. Refer to Table 3 for cable gland specifications.

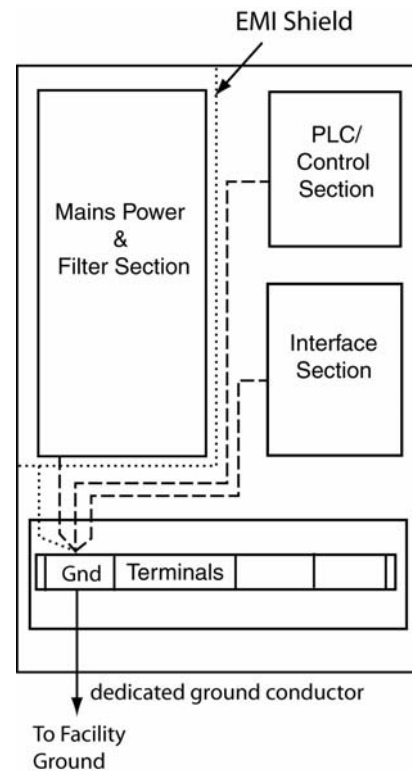

Figure 10 Recommended Panel Layout

Table 1 Maximum Current Ratings for TT300 Compressors

Model Number	Voltage	Current	
		FLA	LRA
TT300-G2-1-ST-N-O-NC	460V	72	80
TT300-G3-1-ST-N-O-NC	460V	80	88
TT300-G4-1-ST-N-O-NC	460V	100	110
TT300-G6-1-ST-N-O-NC	460V	120	132
TT300-G7-1-ST-N-O-NC	460V	135	145
TT300-G2-1-ST-P-O-NC	460V	72	80
TT300-G3-1-ST-P-O-NC	460V	80	88
TT300-G4-1-ST-P-O-NC	460V	100	110
TT300-G6-1-ST-P-O-NC	460V	120	132
TT300-G7-1-ST-P-O-NC	460V	135	145
TT300-G7-1-MT-P-O-NC	460V	135	145
TT300-H6-1-ST-N-O-NC	400V	135	145
TT300-H6-1-ST-P-O-NC	400V	135	145
TT300-H6-1-MT-P-O-NC	400V	135	145
TT300-H6-1-ST-N-O-CE	400V	135	145
TT300-H6-1-ST-P-O-CE	400V	135	145
TT300-H6-1-MT-P-O-CE	400V	135	145
TT300-F2-1-ST-N-O-NC	575V	64	71
TT300-F3-1-ST-N-O-NC	575V	72	80
TT300-F4-1-ST-N-O-NC	575V	80	88

Notes:
 FLA: Full Load Amps
 LRA: Locked Rotor Amps

FLA and LRA are referenced for wire, overload, and disconnect sizing purposes. Actual design operating currents, which are usually lower than FLA values, can be provided by the Danfoss Turbocor Selection Program.

Underwriters’ Laboratories (UL) certification authorities require compressor manufacturers to specify the Locked Rotor Amps (LRA) rating for their equipment. For the Turbocor compressor, LRA is a hypothetical value that generates a critical alarm leading to compressor shutdown.

Table 1 Maximum Current Ratings for TT300 Compressors

Model Number	Voltage	Current	
		FLA	LRA
TT300-F5-1-ST-N-O-NC	575V	90	99
TT300-F6-1-ST-N-O-NC	575V	100	110
TT300-F7-1-ST-N-O-NC	575V	110	121
TT300-F2-1-ST-P-O-NC	575V	64	71
TT300-F3-1-ST-P-O-NC	575V	72	80
TT300-F4-1-ST-P-O-NC	575V	80	88
TT300-F5-1-ST-P-O-NC	575V	90	99
TT300-F6-1-ST-P-O-NC	575V	100	110
TT300-F7-1-ST-P-O-NC	575V	110	121
TT300-F7-1-MT-P-O-NC	575V	110	121

Table 2 Maximum Current Ratings for TT400 Compressors

Model Number	Voltage	Current	
		FLA	LRA
TT400-G4-1-ST-P-O-NC	460V	100	110
TT400-G5-1-ST-P-O-NC	460V	110	121
TT400-G6-1-ST-P-O-NC	460V	120	132
TT400-G8-1-ST-P-O-NC	460V	140	154
TT400-G9-1-ST-P-O-NC	460V	150	165
TT400-H10-1-ST-P-O-NC	400V	180	200
TT400-H10-1-ST-P-O-CE	400V	180	200

Full Load Amps (FLA) refers to the maximum current draw during normal compressor operation. The detection of FLA generates a warning alarm that causes the compressor to adjust its operating conditions so as not to exceed the alarm value.

Table 3 Cable Gland Hole Size Using Teck Cable (TT300 Compressors)

Model Number	Trade Size	Actual Size
TT300-G2-1-ST-N-O-NC	1.5 (38 mm)	1.97" (50 mm)
TT300-G3-1-ST-N-O-NC	1.5 (38 mm)	1.97" (50 mm)
TT300-G4-1-ST-N-O-NC	2.0 (51 mm)	2.48" (63 mm)
TT300-G6-1-ST-N-O-NC	2.0 (51 mm)	2.48" (63 mm)
TT300-G7-1-ST-N-O-NC	2.0 (51 mm)	2.48" (63 mm)
TT300-G2-1-ST-P-O-NC	1.5 (38 mm)	1.97" (50 mm)
TT300-G3-1-ST-P-O-NC	1.5 (38 mm)	1.97" (50 mm)
TT300-G4-1-ST-P-O-NC	2.0 (51 mm)	2.48" (63 mm)
TT300-G6-1-ST-P-O-NC	2.0 (51 mm)	2.48" (63 mm)
TT300-G7-1-ST-P-O-NC	2.0 (51 mm)	2.48" (63 mm)
TT300-G7-1-MT-P-O-NC	2.0 (51 mm)	2.48" (63 mm)
TT300-H6-1-ST-N-O-NC	2.0 (51 mm)	2.48" (63 mm)
TT300-H6-1-ST-P-O-NC	2.0 (51 mm)	2.48" (63 mm)
TT300-H6-1-MT-P-O-NC	2.0 (51 mm)	2.48" (63 mm)
TT300-H6-1-ST-N-O-CE	2.0 (51 mm)	2.48" (63 mm)
TT300-H6-1-ST-P-O-CE	2.0 (51 mm)	2.48" (63 mm)
TT300-H6-1-MT-P-O-CE	2.0 (51 mm)	2.48" (63 mm)
TT300-F2-1-ST-N-O-NC	1.5 (38 mm)	1.97" (50 mm)
TT300-F3-1-ST-N-O-NC	1.5 (38 mm)	1.97" (50 mm)
TT300-F4-1-ST-N-O-NC	1.5 (38 mm)	1.97" (50 mm)

Table 3 (Continued) Cable Gland Hole Size Using Teck Cable (TT300 Compressors)

Model Number	Trade Size	Actual Size
TT300-F5-1-ST-N-O-NC	1.5 (38 mm)	1.97" (50 mm)
TT300-F6-1-ST-N-O-NC	2.0 (51 mm)	2.48" (63 mm)
TT300-F7-1-ST-N-O-NC	2.0 (51 mm)	2.48" (63 mm)
TT300-F2-1-ST-P-O-NC	1.5 (38 mm)	1.97" (50 mm)
TT300-F3-1-ST-P-O-NC	1.5 (38 mm)	1.97" (50 mm)
TT300-F4-1-ST-P-O-NC	1.5 (38 mm)	1.97" (50 mm)
TT300-F5-1-ST-P-O-NC	1.5 (38 mm)	1.97" (50 mm)
TT300-F6-1-ST-P-O-NC	2.0 (51 mm)	2.48" (63 mm)
TT300-F7-1-ST-P-O-NC	2.0 (51 mm)	2.48" (63 mm)
TT300-F7-1-MT-P-O-NC	2.0 (51 mm)	2.48" (63 mm)

Table 4 Cable Gland Hole Size Using Teck Cable (TT400 Compressors)

Model Number	Trade Size	Actual Size
TT400-G4-1-ST-P-O-NC	2.0 (51 mm)	2.48" (63 mm)
TT400-G5-1-ST-P-O-NC	2.0 (51 mm)	2.48" (63 mm)
TT400-G6-1-ST-P-O-NC	2.0 (51 mm)	2.48" (63 mm)
TT400-G8-1-ST-P-O-NC	2.0 (51 mm)	2.48" (63 mm)
TT400-G9-1-ST-P-O-NC	2.0 (51 mm)	2.48" (63 mm)
TT400-H10-1-ST-P-O-NC	2.5 (64 mm)	3.0" (76 mm)
TT400-H10-1-ST-P-O-CE	2.5 (64 mm)	3.0" (76 mm)

Control Interface Wiring

The Compressor Interface module is the entry point for control wiring from the chiller/plant to the compressor.

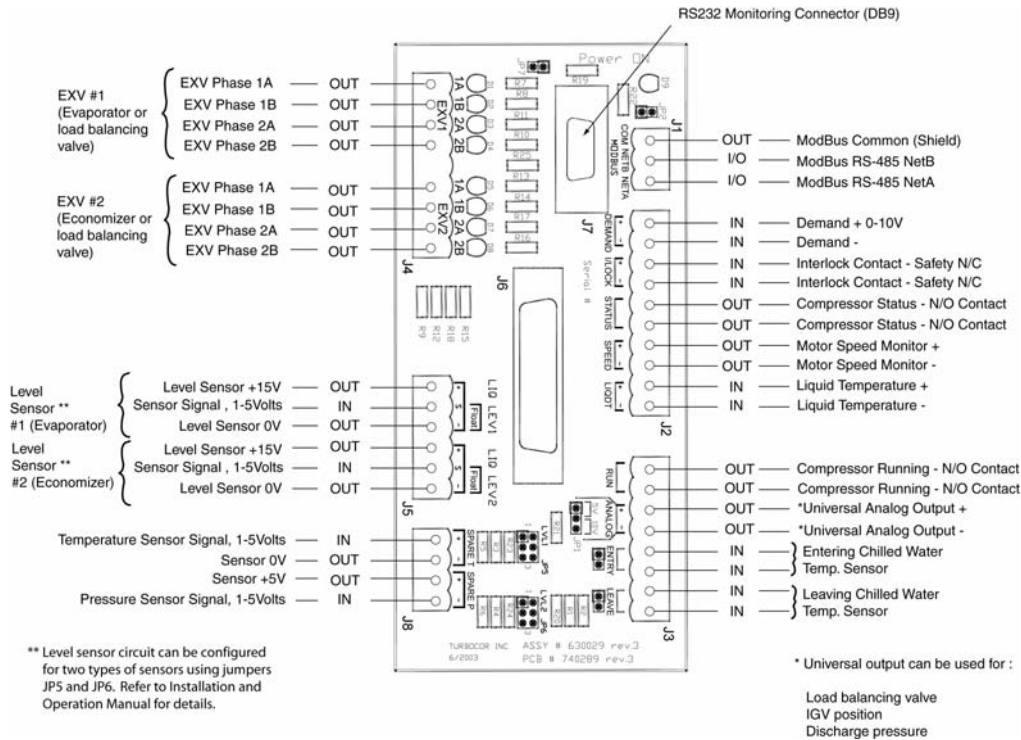

Figure 11 Typical Control Wiring

Table 5 Control Wiring Details

I/O	Description
COM (shield)	Shield for RS-485 communication.
ModBus RS-485 NetB/NetA	ModBus over RS-485 communication port.
EXV Phase 1A, 1B, 2A, 2B (Evaporator)	Optional output connections for controlling the main electronic expansion valve (evaporator).
EXV Phase 1A, 1B, 2A, 2B (Economizer)	Optional output connections for controlling the auxiliary electronic expansion valve (economizer or load balancing valve).
Level Sensor +15V (Evaporator)	Power supply for level sensor #1.
Sensor Signal (Evaporator)	Input from a level sensor to control the main expansion valve (evaporator).
Level Sensor +15V (Economizer)	Power supply for level sensor #2.
Sensor Signal (Economizer)	Input from a level sensor to control the auxiliary expansion valve (economizer).
Demand 0 - 10V	Analog input from customer-supplied controller to drive the compressor, i.e., 0 - max. kW input for the respective compressor model.

Table 5 Control Wiring Details

I/O	Description
Interlock	Connects to a set of external N/C contacts that typically open in the event of loss of chilled water or air flow.
Status	An internal N/O contact that is closed during normal operation and opens in the event of a compressor fault. With circuit open, compressor will not restart until demand signal has been reset to 0 (via chiller/unit controller). Circuit rated at 1A @ 30 VDC/24VAC.
Motor Speed Monitor	Analog output indicating compressor RPM. 0 to 5.0V = 0 to 50,000 RPM.
Liquid Temperature	Reserved for future use.
Run	An internal N/O contact that is closed while the compressor is running. The speed at which the contact closes is user-configurable via the monitor program. Circuit rated at 1A @ 30 VDC/24VAC.
Analog	Universal analog output for load balancing valve, IGV position, or discharge pressure. Operating range can be set to 0-5V or 0-10V via onboard jumpers.
Entering Chilled Water Temp.	Analog input indicating water temperature. The temperature sensor must be an NTC type 10K @ 25°C thermistor. Refer to "Water Temperature Thermistor Specification" on page 19.
Leaving Chilled Water Temp.	Analog input indicating water temperature. The temperature sensor must be an NTC type 10K @ 25°C thermistor. Refer to "Water Temperature Thermistor Specification" on page 19.
Spare T +/-	Reserved for future use. Refer to Table 7 for thermistor specification.
Spare P +/-	Reserved for future use.

Control Wiring Connection Guidelines

To ensure proper control wiring techniques, follow these guidelines:

1. The ground reference of the external circuit connected to the Compressor Interface Module must be at the same potential as the ground reference on the Compressor Interface Module.
2. The Interlock circuit should be voltage-free, i.e., all external contactors/switches must not introduce current into the circuit.
3. Analog outputs (such as Motor Speed) must be received by the external circuit without sending current back to the Compressor Interface Module.
4. All interlock and analog output cables should be shielded with one end of the shield connected to the Compressor Interface Module ground. The other end of the shield must not be grounded as this would create a ground loop.

Interface Cable

The cable that carries the I/O communication to the compressor is 5 meters (16.4 feet) in length and is equipped with high-density 44-pin connectors (female at one end and male at the other end). An extension cable is available from your local supplier.

NOTE:

If an I/O extension cable is used, heat-shrink tubing should be applied to the mating cable connectors to maintain good conductivity and protect the connection from heat and humidity.

For RS-485 communication, the maximum cable length should not exceed 100 meters (328 feet). If using RS-232 communication, the cable length should not exceed 15 meters (50 feet) between the PC and the compressor. Refer to Figure 12.

Compressor Interface Module Mounting Details

The Compressor Interface module (Figure 13) must be installed in an approved electrical enclosure equipped with DIN EN 50022, 50035, or 50045 mounting rails.

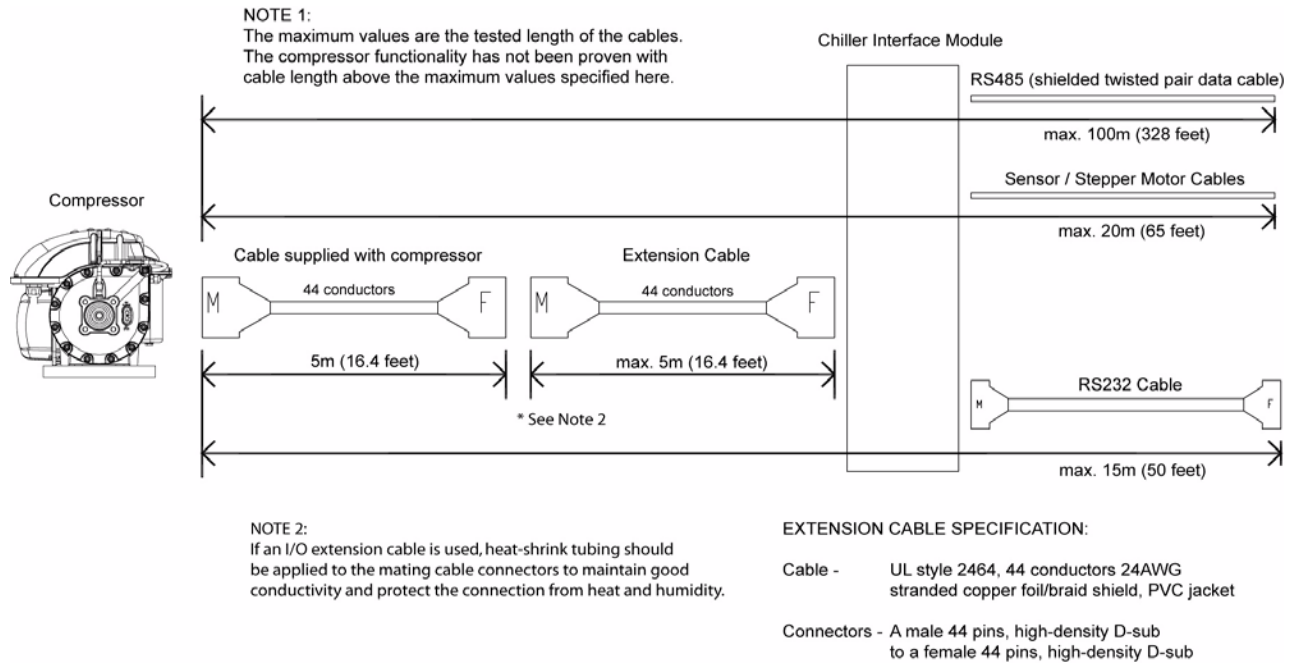

Figure 12 I/O Wiring Specifications

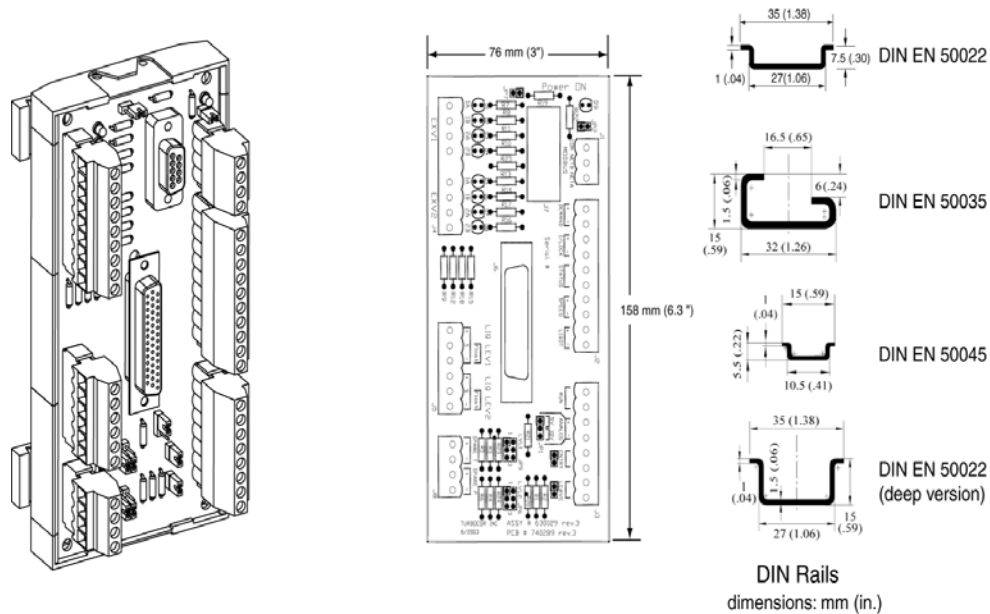

Figure 13 Interface Module

Piping Considerations

Care should be exercised when selecting pipe sizes as they will vary according to their application. *Appendix D: System Design Guidelines (R134a)* provides examples of compressor piping arrangements for the most common applications.

The motor-cooling line should be channeled from the liquid line; refer to paragraph 1.12 of *Appendix D: System Design Guidelines (R134a)* for more information. The motor-cooling port is equipped with an integral strainer to protect the cooling circuit from blockage. Danfoss Turbocor recommends the installation of a sight glass in the motor-cooling line.

NOTE:

Applications may require alternative arrangements. Contact Danfoss Turbocor for further assistance, if required.

⚠ WARNING

The discharge line must be fitted with a non-return valve to prevent reverse flow into the discharge port, which can cause damage to compressor components.

It is recommended that a strainer be installed in the suction line for the first 100 hours of operation, at 80-100% load, to prevent the ingress of foreign particles into the compressor. Impeller damage caused by foreign particles will void the warranty.

All pipework should be carried out in accordance with industry standards. Brazing without the use of nitrogen will result in debris being deposited in the pipes, potentially leading to blockage or damage.

Environmental Considerations

Humidity

If the compressor is installed in a humid environment, drip trays may be required to collect condensate. Insulation should be installed on the suction valve/piping and the end cap as this is where condensation is most likely to form.

Condensate drain holes are provided at the service side and capacitor side of the compressor; refer to Figure 14.

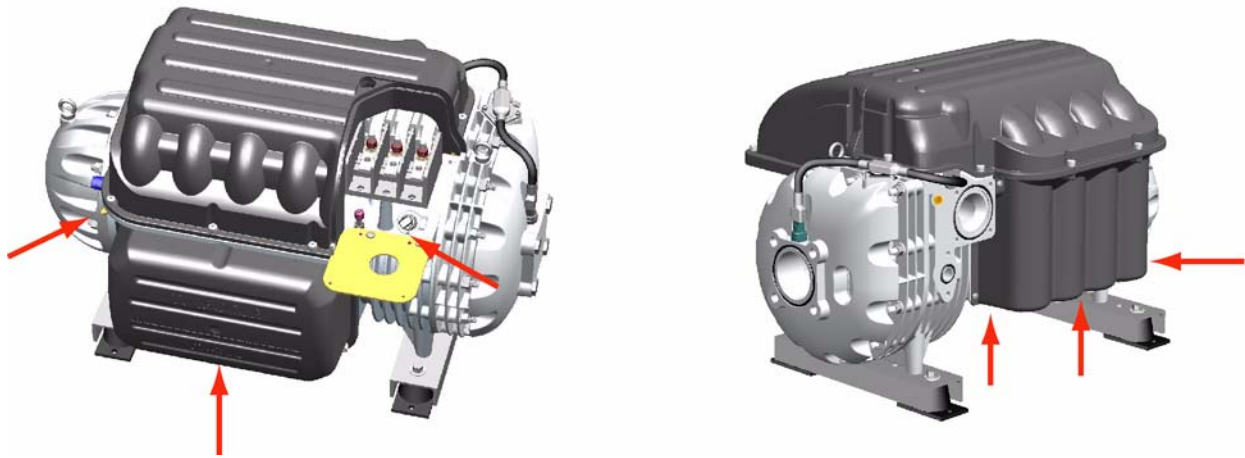

Figure 14 Drain Hole Locations

Vibration

External copper piping should be braced to minimize the transfer of vibration to the compressor.

Shipping Considerations

Vibration

When shipping the compressor as an integral part of a chiller unit, precautions should be taken to protect the compressor motor-cooling line from excessive vibration. Due to the flexibility of the compressor's isolation mounts, compressor vibration during transit can fracture the motor-cooling line's rigid piping. Danfoss Turbocor suggests the temporary installation of an anti-vibration bracket between the compressor's base frame and mounting rail during transit, as shown in Figure 15.

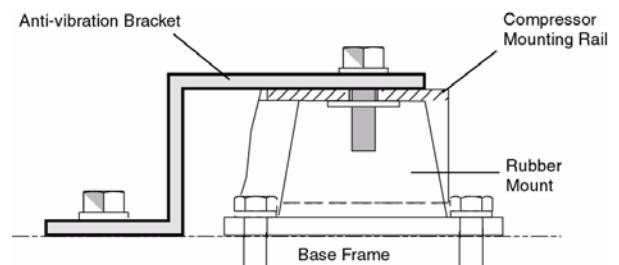

Figure 15 Anti-vibration Bracket

Water Temperature Thermistor Specification

The compressor controller software that monitors the chilled water temperature is based on the NTC thermistor characteristic (10K @ 25°C, curve type F) shown in Figure

16. Detailed resistance vs temperature data is given in Table 6.

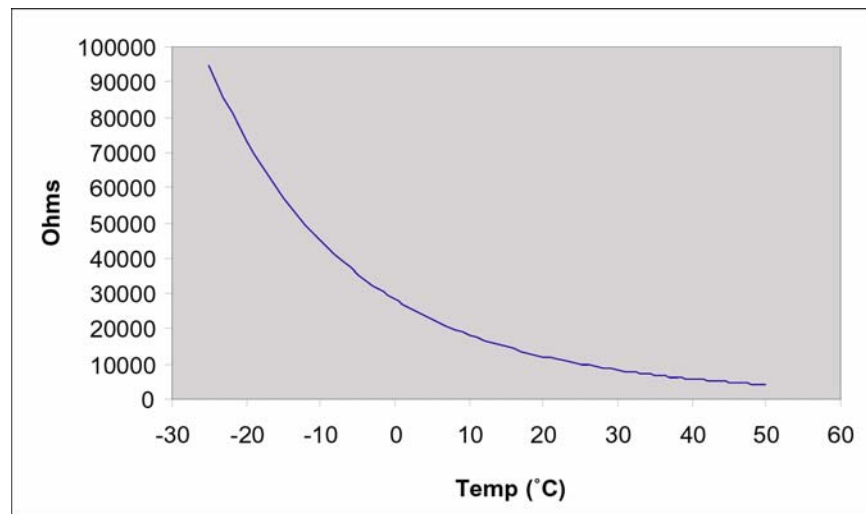

Figure 16 Water Temperature Thermistor Characteristic

Water Temperature Thermistor Specification

Table 6 Thermistor Resistance vs. Temperature

Temp. °C (°F)	Resistance Value			Temp. °C (°F)	Resistance Value			Temp. °C (°F)	Resistance Value		
	Max. kΩ	Standard kΩ	Min. kΩ		Max. kΩ	Standard kΩ	Min. kΩ		Max. kΩ	Standard kΩ	Min. kΩ
-50 (-58)	344.4	329.2	314.7	1 (33.8)	26.64	26.13	25.52	56 (132.8)	3.49	3.42	3.35
-49 (-56.2)	324.7	310.7	297.2	2 (35.6)	25.51	25.03	24.55	57 (134.6)	3.39	3.31	3.24
-48 (-54.4)	306.4	293.3	280.7	3 (37.4)	24.24	23.99	23.54	58 (136.4)	3.28	3.21	3.14
-47 (-52.6)	289.2	277	265.3	4 (39.2)	23.42	22.99	22.57	59 (138.2)	3.18	3.11	3.04
-46 (-50.8)	273.2	261.8	250.6	5 (41)	22.45	22.05	21.66	60 (140)	3.09	3.02	2.95
-45 (-49)	258.1	247.5	237.2	6 (42.8)	21.52	21.15	20.78	61 (141.8)	2.99	2.92	2.86
-44 (-47.2)	244	234.1	224.6	7 (44.6)	20.64	20.29	19.95	62 (143.6)	2.9	2.83	2.77
-43 (-45.4)	230.8	221.6	212.7	8 (46.4)	19.8	19.4	19.15	63 (145.4)	2.81	2.75	2.69
-42 (-43.6)	218.5	209.8	201.5	9 (48.2)	19	18.7	18.4	64 (147.2)	2.73	2.66	2.6
-41 (-41.8)	206.8	198.7	191	10 (50)	18.24	17.96	17.67	65 (149)	2.65	2.58	2.52
-40 (-40)	195.9	188.4	181.1	11 (51.8)	17.51	17.24	16.97	66 (150.8)	2.57	2.51	2.45
-39 (-38.2)	185.4	178.3	171.59	12 (53.6)	16.8	16.55	16.31	67 (152.6)	2.49	2.43	2.37
-38 (-36.4)	175.5	168.9	162.5	13 (55.4)	16.13	15.9	15.87	68 (154.4)	2.42	2.36	2.3
-37 (-34.6)	166.2	160.1	154.1	14 (57.2)	15.5	15.28	15.06	69 (156.2)	2.35	2.29	2.24
-36 (-32.8)	157.5	151.8	146.1	15 (59)	14.89	14.68	14.48	70 (158)	2.28	2.22	2.17
-35 (-31)	149.3	144	138.8	16 (60.8)	14.31	14.12	13.93	71 (159.8)	2.21	2.16	2.1
-34 (-29.2)	141.6	136.6	131.8	17 (62.6)	13.75	13.57	13.4	72 (161.6)	2.15	2.1	2.04
-33 (-27.4)	134.4	129.7	125.2	18 (64.4)	13.22	13.06	12.89	73 (163.4)	2.09	2.04	1.98
-32 (-25.6)	127.6	123.2	118.9	19 (66.2)	12.72	12.56	12.41	74 (165.2)	2.03	1.98	1.93
-31 (-23.8)	121.2	117.1	113.1	20 (68)	12.23	12.09	11.95	75 (167)	1.97	1.92	1.87
-30 (-22)	115.1	111.3	107.5	21 (69.8)	11.77	11.63	11.57	76 (168.8)	1.92	1.87	1.82
-29 (-20.2)	109.3	105.7	102.2	22 (71.6)	11.32	11.2	11.07	77 (170.6)	1.86	1.81	1.78
-28 (18.4)	103.8	100.4	97.16	23 (73.4)	10.9	10.78	10.6	78 (172.4)	1.81	1.76	1.71
-27 (-16.6)	98.63	95.47	92.41	24 (75.2)	10.49	10.38	10.27	79 (174.2)	1.76	1.71	1.68
-26 (-14.8)	93.75	90.8	87.93	25 (77)	10.1	10	9.9	80 (176)	1.71	1.66	1.62
-25 (-13)	89.15	86.39	83.7	26 (78.8)	9.73	9.63	9.52	81 (177.8)	1.66	1.62	1.57
-24 (-11.2)	84.82	82.22	79.71	27 (80.6)	9.38	9.28	9.18	82 (179.6)	1.62	1.57	1.53
-23 (-9.4)	80.72	78.29	75.93	28 (82.4)	9.04	8.94	8.84	83 (181.4)	1.57	1.53	1.49
-22 (-7.6)	76.85	74.58	72.36	29 (84.2)	8.72	8.62	8.52	84 (183.2)	1.53	1.49	1.44
-21 (-5.8)	73.2	71.07	68.99	30 (86)	8.41	8.31	8.21	85 (185)	1.49	1.45	1.4
-20 (-4)	69.74	67.74	65.8	31 (87.8)	8.11	8.01	7.91	86 (186.8)	1.45	1.41	1.37
-19 (-2.2)	66.42	64.54	62.72	32 (89.6)	7.82	7.72	7.62	87 (188.6)	1.41	1.37	1.33
-18 (-0.4)	63.27	61.52	59.81	33 (91.4)	7.55	7.45	7.35	88 (190.4)	1.37	1.33	1.29
-17 (1.4)	60.3	58.66	57.05	34 (93.2)	7.28	7.19	7.09	89 (192.2)	1.34	1.3	1.26
-16 (3.2)	57.49	55.93	54.39	35 (95)	7.03	6.94	6.84	90 (194)	1.3	1.26	1.22
-15 (5)	54.83	53.39	51.97	36 (96.8)	6.79	6.69	6.6	91 (195.8)	1.27	1.23	1.19
-14 (6.8)	52.31	50.96	49.83	37 (98.6)	6.56	6.46	6.37	92 (197.6)	1.23	1.2	1.16
-13 (8.6)	49.93	48.65	47.12	38 (100.4)	6.33	6.24	6.15	93 (199.4)	1.2	1.16	1.13
-12 (10.4)	47.67	46.48	45.31	39 (102.2)	6.12	6.03	5.94	94 (201.2)	1.17	1.13	1.1
-11 (12.2)	45.53	44.41	43.32	40 (104)	5.92	5.82	5.73	95 (203)	1.14	1.1	1.07
-10 (14)	43.5	42.25	41.43	41 (105.8)	5.72	5.63	5.54	96 (204.8)	1.11	1.08	1.04
-9 (15.8)	41.54	40.56	39.59	42 (107.6)	5.53	5.43	5.35	97 (206.6)	1.08	1.05	1.01
-8 (17.6)	39.68	38.76	37.85	43 (109.4)	5.34	5.25	5.17	98 (208.4)	1.05	1.02	0.99
-7 (19.4)	37.91	37.05	36.2	44 (111.2)	5.16	5.08	4.99	99 (210.2)	1.03	0.99	0.96
-6 (21.2)	36.24	35.43	34.02	45 (113)	4.99	4.91	4.82	100 (212)	1	0.97	0.94
-5 (23)	34.65	33.89	33.14	46 (114.8)	4.83	4.74	4.66	101 (213.8)	0.98	0.94	0.91
-4 (24.8)	33.14	32.43	31.73	47 (116.6)	4.67	4.59	4.51	102 (215.6)	0.95	0.92	0.89
-3 (26.6)	31.71	31.04	30.39	48 (118.4)	4.52	4.44	4.36	103 (217.4)	0.93	0.9	0.87
-2 (28.4)	30.35	29.72	29.09	49 (120.2)	4.38	4.3	4.22	104 (219.2)	0.91	0.87	0.84
-1 (30.2)	30	28.47	27.89	50 (122)	4.24	4.16	4.08	105 (221)	0.88	0.85	0.82
0 (32)	27.83	27.28	26.74	51 (123.8)	4.1	4.02	3.95	106 (222.8)	0.86	0.83	0.8
				52 (125.6)	3.97	3.9	3.82	107 (224.6)	0.84	0.81	0.78
				53 (127.4)	3.84	3.77	3.69	108 (226.4)	0.82	0.79	0.76
				54 (129.2)	3.72	3.65	3.57	109 (228.2)	0.8	0.77	0.74
				55 (131)	3.61	3.53	3.46	110 (230)	0.78	0.75	0.73

Combined Temperature/Pressure Thermistor Specification

The compressor controller software that monitors the combined pressure/temperature sensor at the suction port

and spare input on the Compressor Interface module is based on the NTC thermistor data detailed in Table 7.

Table 7 Thermistor Resistance vs Temperature

Temp. (°C)	Temp. (°F)	Resistance (ohms)	Temp. (°C)	Temp. (°F)	Resistance (ohms)
-20	-4	94143	20	68	12474
-15	5	71172	25	77	10000
-10	14	54308	30	86	8080
-5	23	41505	35	95	6569
0	32	32014	40	104	5372
5	41	25011	45	113	4424
10	50	19691	50	122	3661
15	59	15618			

Appendix A: Danfoss Turbocor Product Ordering Guide

Model Nomenclature

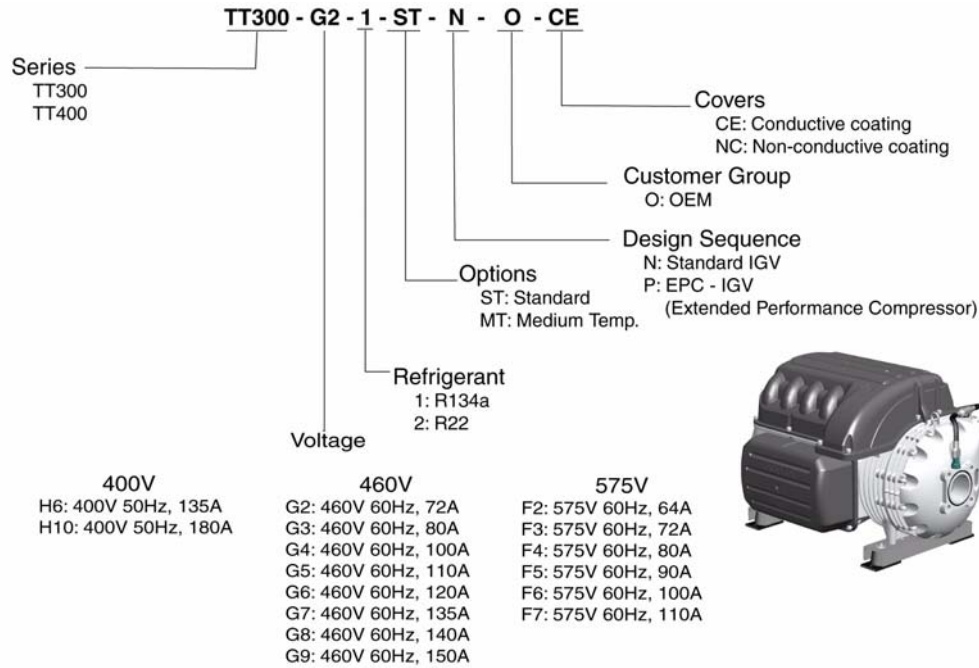

TT300 Compressors:

Model Number	Part Number	Discharge Pressure Limit kPa (psi)	Input Voltage
TT300-F2-1-ST-N-O-NC	170201	1240 (180)	575V
TT300-F3-1-ST-N-O-NC	170202	1240 (180)	575V
TT300-F4-1-ST-N-O-NC	170203	1240 (180)	575V
TT300-F5-1-ST-N-O-NC	170204	1240 (180)	575V
TT300-F6-1-ST-N-O-NC	170205	1600 (232)	575V
TT300-F7-1-ST-N-O-NC	170206	1600 (232)	575V
TT300-F2-1-ST-P-O-NC	170208	1240 (180)	575V
TT300-F3-1-ST-P-O-NC	170209	1240 (180)	575V
TT300-F4-1-ST-P-O-NC	170210	1240 (180)	575V
TT300-F5-1-ST-P-O-NC	170211	1240 (180)	575V
TT300-F6-1-ST-P-O-NC	170212	1800 (260)	575V
TT300-F7-1-ST-P-O-NC	170213	1800 (260)	575V
TT300-F7-1-MT-P-O-NC	170214	1240 (180)	575V
TT300-G2-1-ST-N-O-NC	170001	1240 (180)	460V

Model Number	Part Number	Discharge Pressure Limit kPa (psi)	Input Voltage
TT300-G3-1-ST-N-O-NC	170002	1240 (180)	460V
TT300-G4-1-ST-N-O-NC	170003	1240 (180)	460V
TT300-G6-1-ST-N-O-NC	170004	1600 (232)	460V
TT300-G7-1-ST-N-O-NC	170005	1600 (232)	460V,
TT300-G2-1-ST-P-O-NC	170008	1240 (180)	460V
TT300-G3-1-ST-P-O-NC	170009	1240 (180)	460V,
TT300-G4-1-ST-P-O-NC	170010	1240 (180)	460V,
TT300-G6-1-ST-P-O-NC	172000	1800 (260)	460V
TT300-G7-1-ST-P-O-NC	170012	1800 (260)	460V
TT300-G7-1-MT-P-O-NC	170013	1240 (180)	460V
TT300-H6-1-ST-N-O-NC	170104	1600 (232)	400V
TT300-H6-1-ST-N-O-CE	170115	1600 (232)	400V
TT300-H6-1-ST-P-O-NC	170109	1800 (260)	400V
TT300-H6-1-ST-P-O-CE	170121	1800 (260)	400V
TT300-H6-1-MT-P-O-NC	170110	1240 (180)	400V
TT300-H6-1-MT-P-O-CE	170123	1240 (180)	400V

TT400 Compressors:

Model Number	Part Number	Discharge Pressure Limit kPa (psi)	Input Voltage
TT400-G4-1-ST-P-O-NC	170014	1240 (180)	460V
TT400-G5-1-ST-P-O-NC	170015	1240 (180)	460V
TT400-G6-1-ST-P-O-NC	170016	1240 (180)	460V
TT400-G8-1-ST-P-O-NC	170017	1240 (180)	460V
TT400-G9-1-ST-P-O-NC	170018	1240 (180)	460V,
TT400-H10-1-ST-P-O-NC	170129	1240 (180)	400V
TT400-H10-1-ST-P-O-CE	170134	1240 (180)	400V

TT300 Accessories:

Description	Part Number	Notes
Valve Kits		
Suction service valve kit	100412	Kit includes one 3-1/8" suction valve with o-ring, lubrication, and attaching hardware.
Suction flange kit (flat face)	100402	Kit includes one 3-1/8" brass flange with o-ring, lubrication, and attaching hardware.
Discharge service valve/non-return valve kit	100413	Kit includes one straight 2-1/8" discharge valve with integral non-return valve, o-ring, lubrication, and attaching hardware.
Non-return valve/flange kit	100479	Kit includes one 2-1/8" discharge non-return valve, o-ring, lubrication, and attaching hardware.
Economizer service valve kit	100014	Kit includes one 7/8" economizer valve with o-ring, lubrication, and attaching hardware.
7/8" flange kit (economizer)	100400	Kit includes one 7/8" flange with o-ring, lubrication, and attaching hardware.
Suction flange kit (grooved face)	100401	Kit includes one 3-1/8" brass flange with o-ring, lubrication, and attaching hardware.
Insulated end bell cover	100147	Kit includes installation instructions.
Suction strainer kit	100472	Kit includes strainer, 3-1/8" housing, o-ring, lubrication, and attaching hardware.
Mounting kit	100066	Kit includes four rubber mounts with attaching hardware. Attaching hardware includes four sets of 3/8" screws, spring washers, and flat washers.
Line reactor	901453 (140A)	10% impedance. Order this part number when line reactor is used in conjunction with Harmonic Filter. Kit includes installation instructions.
Line reactor	901974 (140A)	5% impedance. Kit includes installation instructions.
EMI/EMC Filter	901665 (UL)	185A, 480V or below, UL compliant. Kit includes installation instructions.
EMI/EMC Filter	901666 (CE)	185A, 480V or below, CE compliant. Kit includes installation instructions.
Harmonic Filter	901887 (140A, 60Hz)	Kit includes installation instructions.

TT400 Accessories:

Description	Part Number	Notes
Valve Kits		
Discharge flange kit, 2" brass	100152	Kit includes flange, o-ring, lubrication, and attaching hardware.
Discharge flange kit, 2" steel	100153	Kit includes flange, o-ring, lubrication, and attaching hardware.
Suction flange kit	100151	Kit includes flange, o-ring, lubrication, and attaching hardware.

Description	Part Number	Notes
Suction flange kit (flat face)	100402	Kit includes one 3-1/8" brass flange with o-ring, lubrication, and attaching hardware.
Insulated end bell cover	100147	Kit includes installation instructions.
Mounting kit	100066	Kit includes four rubber mounts with attaching hardware. Attaching hardware includes four sets of 3/8" screws, spring washers, and flat washers.
Line reactor	901454 (180A)	10% impedance. Order this part number when line reactor is used in conjunction with Harmonic Filter. Kit includes installation instructions.
Line reactor	901975 (185A)	5% impedance. Kit includes installation instructions.
EMI/EMC Filter	901665 (UL)	185A, 480V or below, UL compliant. Kit includes installation instructions.
EMI/EMC Filter	901666 (CE)	185A, 480V or below, CE compliant. Kit includes installation instructions.
Harmonic Filter	TBC	(TBC) Contact DTCL for availability and technical info.

Appendix B: Physical Data

This section contains data relative to compressor mounting, service clearance, and piping connections.

1 Mounting Base

The compressor must be mounted on a rigid surface of sufficient structural integrity to support the weight of the compressor and valves. A mounting kit is available to isolate the compressor from the supporting structure and to

minimize vibration from other rotating equipment. The compressor mounting rails should be level $\pm 3/16$ " (5mm) in the lateral and longitudinal planes.

2 Clearance

Adequate clearance around the compressor is essential to facilitate maintenance and service. Removal of the

compressor top and service-side covers requires a minimum clearance of 12" (300mm) and 8" (203mm), respectively.

3 Valve Flanges

 **WARNING**

The discharge valve must be fitted with a check valve to prevent reverse flow into the discharge port which can cause damage to compressor components.

Compressor valve flange details are shown in Figure B-6 and Figure B-7.

Danfoss Turbocor offers 7/8-inch and 3-1/8-inch flanges as compressor accessories. Refer to the product specifications in Appendix E for further details.

4 Piping Expanders

Suggested piping expander details for the TT400 suction and discharge ports are shown in Figure B-8, Figure B-9, and Figure B-10.

Suction/Front View of Compressor

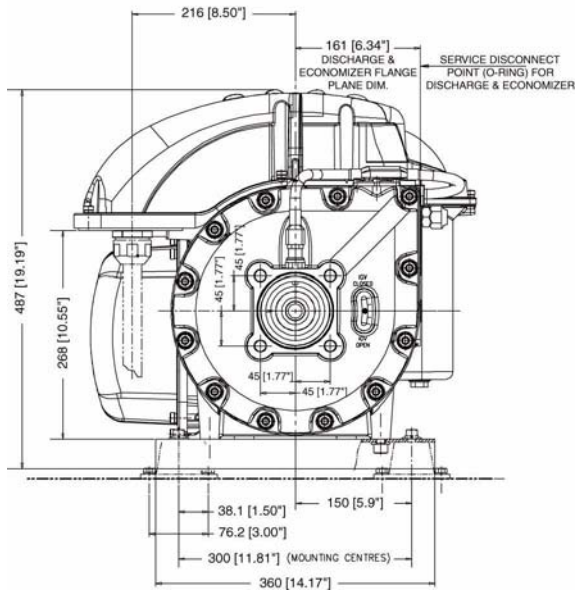

Figure B-1

Service/AC Main Power Side of Compressor

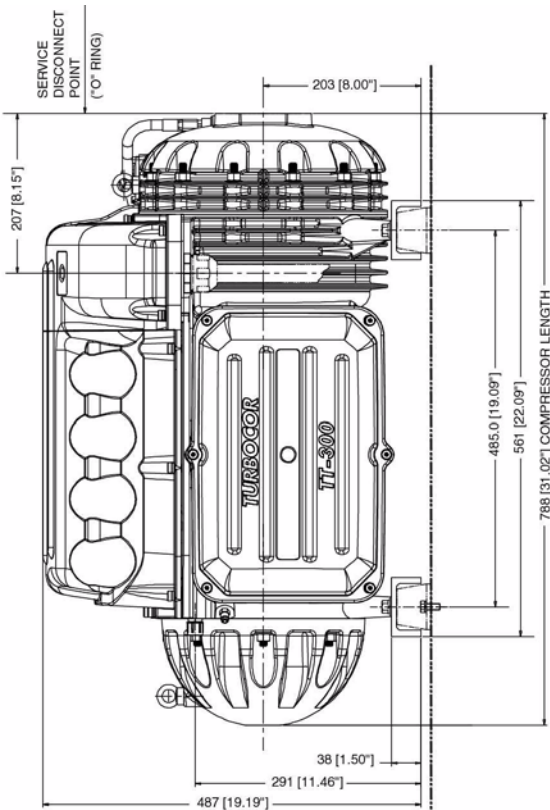

Figure B-2

Length 31.02" (788 mm)
(excludes suction service valve)

Width 20.4" (518 mm)

Height 19.17" (487 mm)

Shipping weight TT300: 265 lbs. (120 kg),
TT400: 300 lbs. (136 kg)

Refrigerant R-134a

Discharge Side View of Compressor (TT300 only)

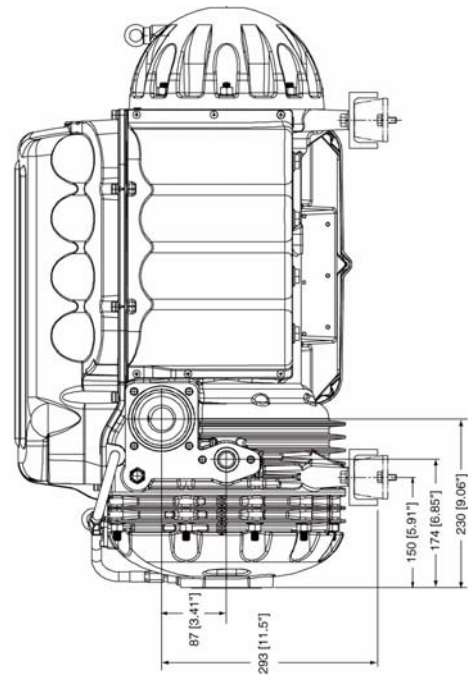

Figure B-3

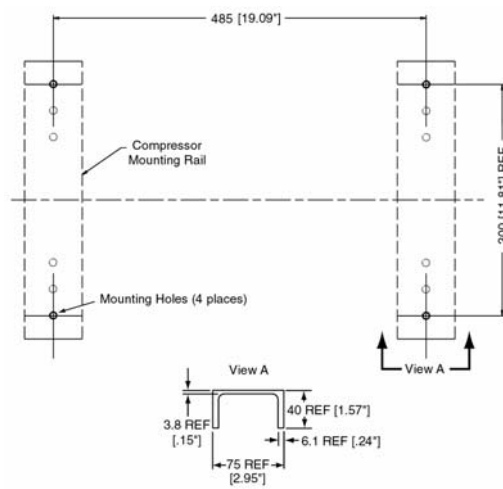

Figure B-4

Discharge Side View of Compressor (TT400 only)

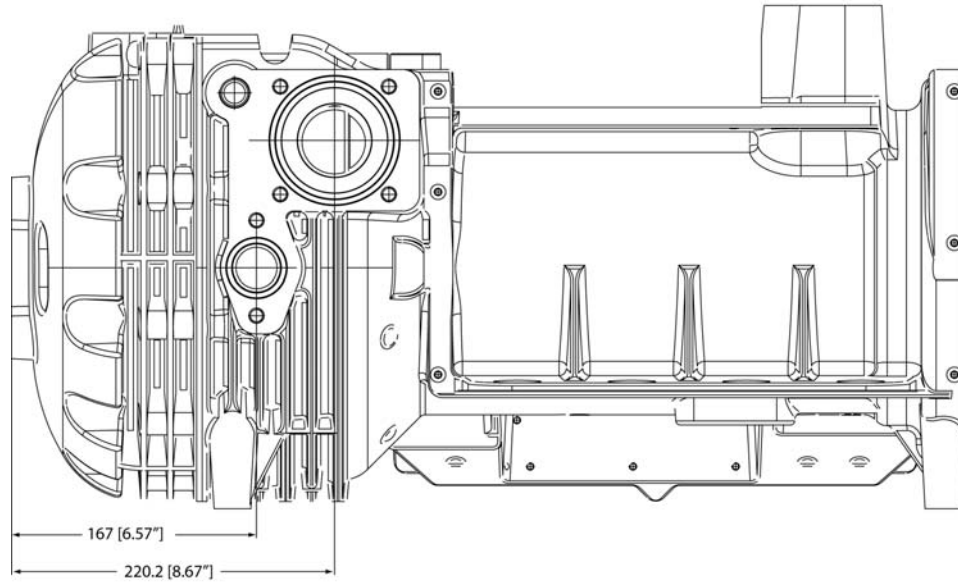

Figure B-5

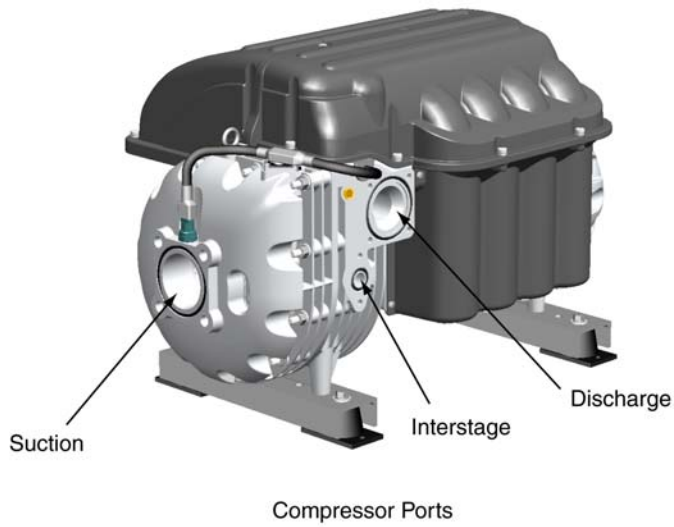
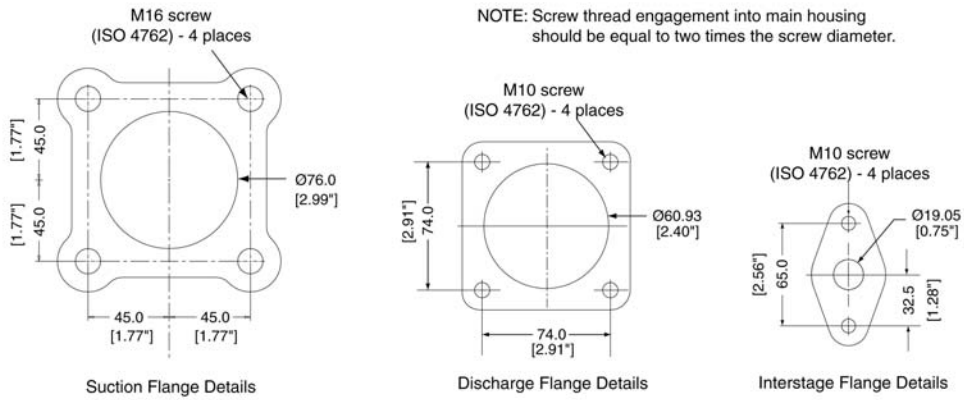

Figure B-6 TT300 Valve Flange Details

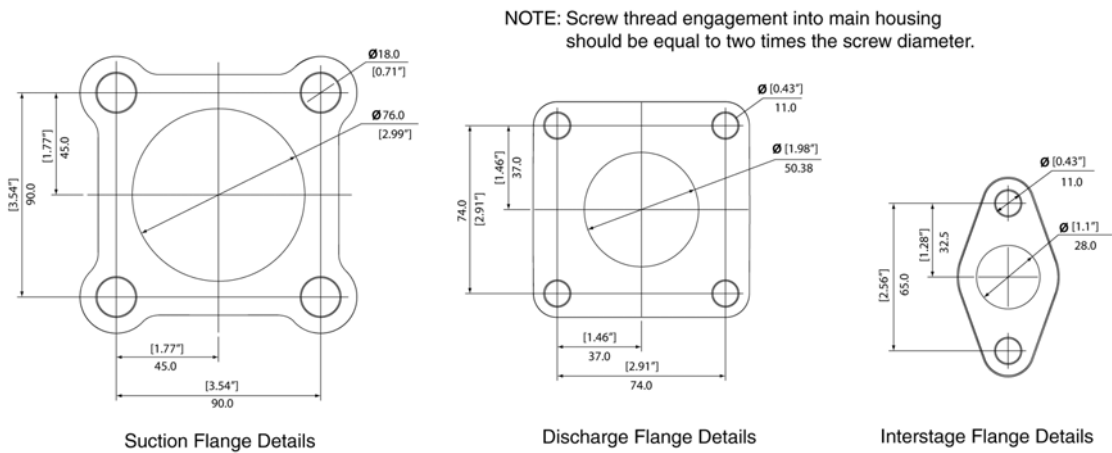

Figure B-7 TT400 Valve Flange Details

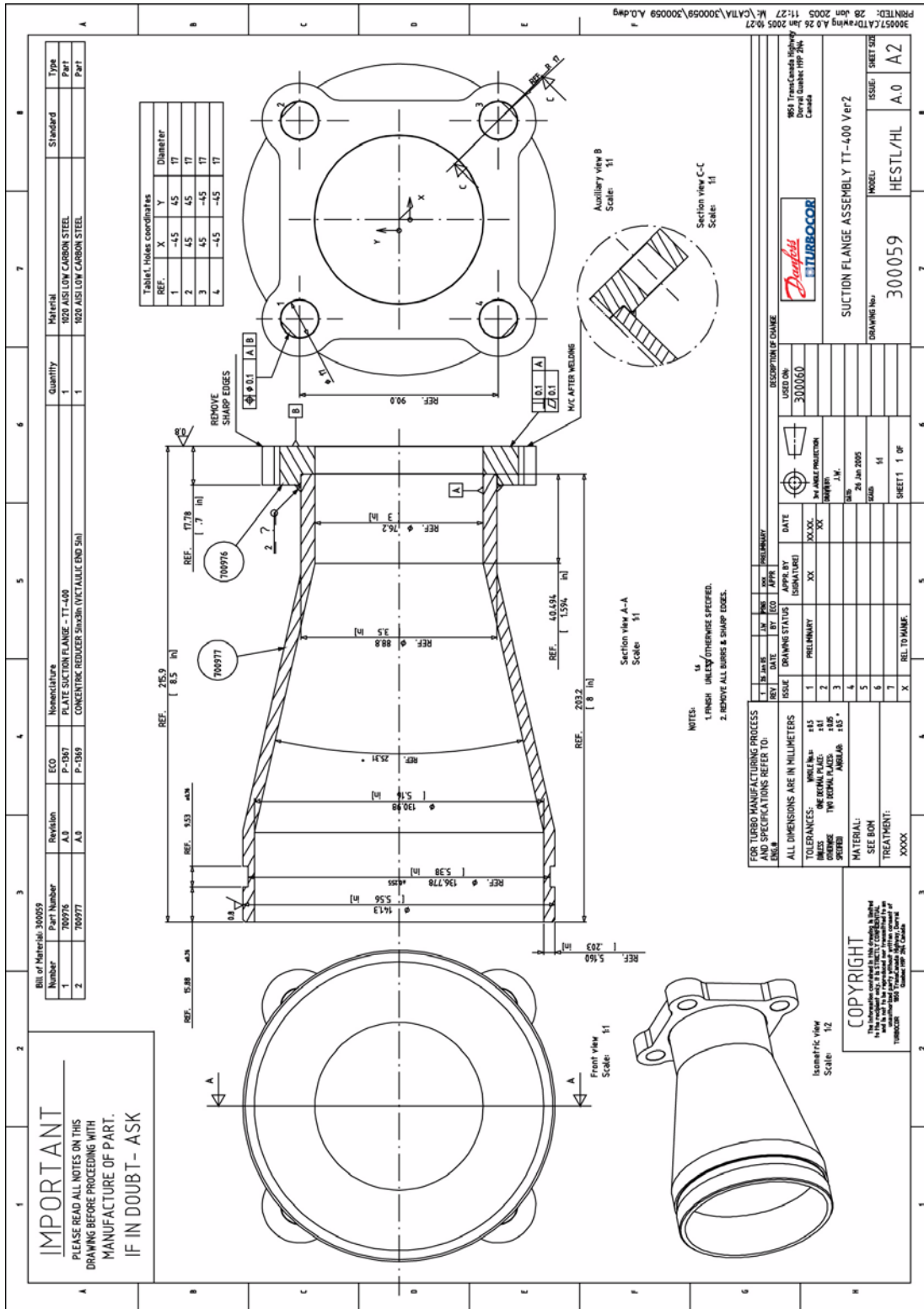

Figure B-8 Suggested TT400 Suction Expander Details

Appendix C: TT300 and TT400 Centrifugal Compressor Guide Specification

1 General

Construction shall utilize a two stage, variable speed, centrifugal compressor design requiring no oil for lubrication. Compressor shall be constructed with cast aluminum casing and high-strength thermoplastic

electronics enclosures. The two-stage centrifugal impellers shall consist of cast and machined aluminum. The motor rotor and impeller assembly shall be the only major moving parts.

2 Refrigerant

Compressors shall be designed for use with HFC-134a.

3 Compressor Bearings

The compressor shall be provided with radial and axial magnetic bearings to levitate the shaft thereby eliminating metal to metal contact, and thus eliminating friction and the need for oil. The magnetic bearing system shall consist of front, rear, and axial bearings. Both the front and the rear

bearings are to levitate the shaft at X and Y directions, and the axial at Z direction. Each bearing position shall be sensed by position sensors to provide real-time repositioning of the rotor shaft, controlled by on-board digital electronics.

4 Capacity Control

The compressor shall have a Variable Frequency Drive (VFD) for linear capacity modulation, high part-load efficiency and reduced in-rush starting current under 2 amps at 460V. It shall include an IGBT (Insulated Gate Bipolar Transistor) type inverter that converts the DC voltage to an adjustable three-phase AC voltage. Signals from the compressor controller shall determine the inverter output frequency, voltage and phase, thereby regulating the motor speed. In case of power failure, the compressor shall be capable of allowing for a normal de-levitation and shutdown.

Compressor speed shall be reduced as condensing temperature and/or heat load reduces, optimizing energy performance through the entire range from 100% to 30% or below of full-load capacity of each compressor given ARI unloading conditions. Capacity modulates infinitely as motor speed is varied across the range. Inlet Guide Vanes (IGV) shall be built-in to further trim the compressor capacity in conjunction with the variable-speed control, to optimize compressor performance at low loads.

5 Compressor Motor

The compressor shall be provided with a direct drive, high efficiency, permanent-magnet synchronous motor powered by pulse-width-modulating (PWM) voltage supply. The motor shall be compatible with high-speed variable

frequency operation that affords high speed efficiency, compactness and soft start capability. Motor cooling shall be by liquid refrigerant injection.

6 Compressor Electronics

The compressor shall include a microprocessor controller capable of controlling magnetic bearings and speed control. Controller shall be capable of providing monitoring

including commissioning assistance, energy outputs, operation trends, and fault codes via a Modbus interface.

7 Ancillary Devices

A non-return valve shall be installed on the discharge port of the compressor to protect against backflow of refrigerant

during coastdown. The system shall also be provided with an appropriately-sized line reactor.

Appendix D: System Design Guidelines (R134a)

In addition to the instructions detailed in the TT300 and TT400 technical documentation set, this section provides basic guidelines and requirements for the design and manufacture of R134a systems equipped with Danfoss Turbocor compressors.

Refer to the applicable Danfoss Turbocor technical manual for applications, operating, installation and commissioning instructions.

This document applies to the following systems:

- Water-cooled Unit
- Evaporative-cooled Unit
- Low Evaporating Temperature Application
- Air-cooled Unit
- One compressor on multiple evaporators system
- Multiple compressors on common circuit using one evaporator and one condenser
- Packaged air-side unit with D-X type evaporator and multiple evaporator coils

NOTE:

The compressor internal protection devices are for the compressor purposes only, which is only one component in the system. While the internal protection devices may be used to enhance system protection, the system should be equipped with its own protection means. DTCI shall not be made responsible for any system related fault or damage.

1 General Requirements

- | | |
|--|---|
| <p>1.1 Check all installation, operating, commissioning and service steps, as outlined in the TT300 and TT400 documentation set. Check the operating envelope and minimum unloading capacity for compressor application limits, typical main power input schematic, and the typical refrigerant piping schematic.</p> <p>1.2 We strongly suggest fitting Danfoss Turbocor recommended accessories.</p> <p>1.3 System components such as evaporators, condensers, valves, etc., should be properly selected and sized for performance and compatibility to suit R134a refrigerant.</p> <p>1.4 The system suction and discharge piping should be properly designed and selected for minimum pressure drop. R134a refrigerant vapour has high specific volume and a high rate of corresponding saturated temperature change for a given pressure change. This requirement is more critical with the suction line.</p> | <p>1.5 For improved efficiency, smoother control, and better unloading, electronic expansion valves (EEV/EXVs) are strongly recommended. Thermal expansion valves (TXVs) are not recommended due to the minimum pressure differential required to operate, hence reduced unloading capability and efficiency of the compressor.</p> <p>1.6 Take all the necessary precautions to prevent any possibility of liquid floodback. Install a specially designed accumulator if liquid floodback is of concern. Standard accumulators must be modified to suit and be fitted with a fine strainer.</p> <p>1.7 A suction strainer is advised for applications where a clean system cannot be assured. For the TT300, a recommended suction strainer is available from Danfoss Turbocor. Refer to the Suction Strainer Product Spec. Sheet.</p> <p>1.8 Check all pipes and pipe connections to ensure that all are clean and free of any debris</p> |
|--|---|

-
- 1.9 For outdoor installations, a weather-proof enclosure is recommended to house the compressor in order to protect the electronics from moisture and dust during operation and servicing.
 - 1.10 Liquid lines must be fitted with solenoid valves before the expansion valve.
 - 1.11 To ensure sub-cooled liquid where the system is not equipped with a liquid receiver, it is important that the condenser is fitted with a subcooler (integrated or separate).
 - 1.12 The motor-cooling liquid line must be connected to the downward leg of a tee fitting after the liquid line dryer and before the solenoid valve and then continue upward; this is to ensure that the motor-cooling line is fed with liquid refrigerant at all times. Recommended pipe size is 5/8".

NOTE:

Filter dryer, sight glass and service valve should be fitted in the motor cooling liquid line as per the relevant refrigeration piping schematic.

- 1.13 Check condenser position and discharge gas piping for possible liquid backflow from the condenser and/

or pipeline, particularly if the condenser is located at a higher position than the compressor.

- 1.14 A Load Balancing Valve (LBV) must be installed to ensure stable unloaded operation and aid the lag compressor start-up in multiple compressor systems.
- 1.15 Charge only vapour refrigerant through suction line. Do not charge liquid through the suction line.
- 1.16 The system control should not be designed based on pumpdown at shutting down. The system cannot be completely pumped down due to the surge constraint of this compressor.
- 1.17 For the TT300, the recommended suction and discharge copper pipe sizes are 3-1/8" and 2-5/8" respectively. For long pipe runs and/or more than one 90° bend (elbow) on the suction line, use 3-5/8" or 4-1/8" pipe to avoid excessive pressure drop.

For the TT400, the recommended discharge and suction pipe sizes are 3-1/8" and 5", respectively. Proper expander trumpets with smooth transitions must be used to connect the compressor flanges to the pipelines.

- 1.18 In humid environments, the bell housing of the compressor should be insulated. An insulated cover is available as an accessory.

2 Electrical Requirements

- 2.1 Reactor enclosure or box should be properly ventilated to avoid overheating.

- 2.2 Danfoss Turbocor strongly recommends installation of a properly selected surge suppressor on the power supply to the compressor. Refer to wiring diagram.

3 Control Requirements

 **WARNING**

The thermal expansion of liquid trapped between the Electronic Expansion Valve (EXV) and the Liquid Line Solenoid (LLS) can rupture the liquid line during off-cycle periods. To safeguard against this hazard, ensure that the EXV closes a few seconds **after** closing the LLS during system shutdown.

- 3.1 It is recommended to implement a minimum 3 minute start up time delay with minimum 5 minute run time to ensure that motor cooling is present.

- 3.2 Each evaporator expansion system should be controlled independently using its suction line pressure and temperature.
- 3.3 Special control logic for the multiple compressors.
- 3.4 When an external EXV controller is used, minimum valve opening at start-up and unloading is required in the control algorithm. The suggested minimum opening is approximately 10%.
- 3.5 Proper loading and unloading time delays should be implemented on all the above stages.
- 3.6 Main liquid line solenoid valve opens/closes at 12,000 - 15,000 RPM.

- 3.7 Economizer liquid solenoid valve opens/closes at 20,000 RPM.
- 3.8 External suction temperature sensor must be fitted when superheat control of the electronic expansion valve is used.

NOTE:

The factory-installed temperature sensor on the compressor suction port should not be used for this purpose.

4 Application-specific Requirements

4.1 Medium Evaporating Temperature Application

- 4.1.1 Check operating envelope for limits, required compressor version, and accessories.

- 4.1.2 For medium-temperature applications, a motor-cooling regulating valve must be installed. Recommended valve: Sporlan ORIT-10 7/8". Set at 200 kPa (30 psi) for R134a.

4.2 Air-Cooled Units

- 4.2.1 Air-cooled condensers must be properly installed to avoid any possible air flow restriction or recycling.
- 4.2.2 For improved efficiency and smooth operation in conjunction with electronic expansion valve installations, condenser fan staging needs to be checked, i.e., lower the pressure settings and widen

the differential. First-stage fans with variable speed are highly recommended if the unit operates in cold ambient temperatures. Minimum fan pressure setting should be at least 150 kPa (20 psi) above the suction pressure; this value should be increased if an excessive pressure drop across the condenser and liquid line is experienced.

4.3 Multiple Compressors on Common Circuit Using One Evaporator and One Condenser

- 4.3.1 Motor-cooling liquid should be fed from the common liquid line. Follow the instructions in paragraph 1.12.
- 4.3.2 It is recommended to apply similar, or ideally the same, suction and discharge piping layout for all individual compressors so that the pressure drop on the lines is equal or least close to equal.
- 4.3.3 Install positive-seal one-way valve on each compressor discharge line to protect the compressor from possible liquid back flow.
- 4.3.4 Compressor suction and discharge ports should be connected to the vessels. In cases where this is not practical, large diameter headers must be used to connect multiple suction and discharge pipes. Header size depends on the number of compressors connected. As a guide, the minimum header size for two compressors should be 15 cm (6 inches) by 2 meters (6 feet) for discharge and 20 cm (8 inches) by 2.5 meters (8 feet) for suction.

- 4.3.5 Special control algorithm is required if multiple compressors are to be installed in parallel in a single circuit.
- 4.3.6 During the compressor staging process, to get the lag compressor on line, the system pressure ratio should be below a maximum level of 2.5.
- 4.3.7 Load Balancing Valve (LBV) is required for staging multiple compressors at high-pressure ratio. Take-off point from the discharge line should be upstream of the non-return valve.
- 4.3.8 Maximum pressure ratio at start-up is about 2.4. If the pressure ratio is higher than 2.4, an LBV is required to reduce the pressure ratio before starting the compressor.
 $\text{Pressure ratio} = \frac{\text{absolute discharge pressure}}{\text{absolute suction pressure}}$

NOTE:

Contact Danfoss Turbocor for compressor selection and technical advice.

4.4 Packaged Air-side With D-X Type Evaporator and Multiple Evaporator Coils

- 4.4.1 Each evaporator must be controlled by an independent expansion system, using its outlet header for superheat control reference. Common suction temperature or pressure should not be used for individual evaporator superheat control reference points. Also, refer to paragraph 1.5.
- 4.4.2 Each evaporator liquid line should be equipped with a solenoid valve.
- 4.4.3 Connection of a generously-sized header to the suction line of the evaporators is recommended to minimize pressure drop differences.
- 4.4.4 It is highly recommended to install a suction line accumulator as detailed in paragraph 1.6.
- 4.4.5 Motor-cooling liquid should be fed from the common liquid line. Follow the instructions in paragraph 1.12.

5 Sample Refrigeration Circuits

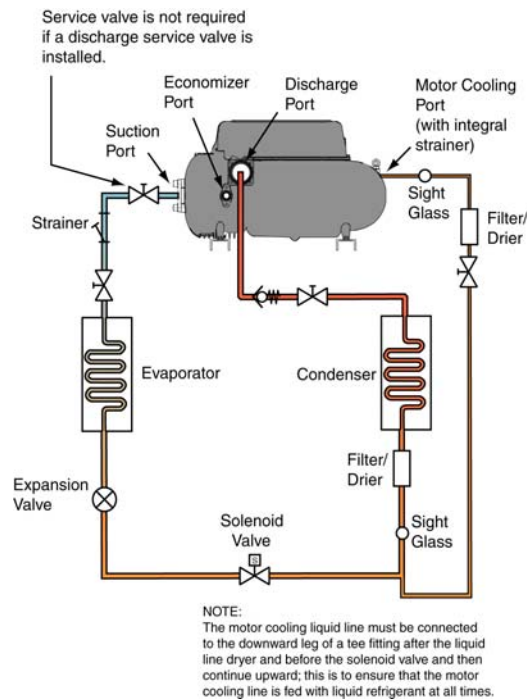
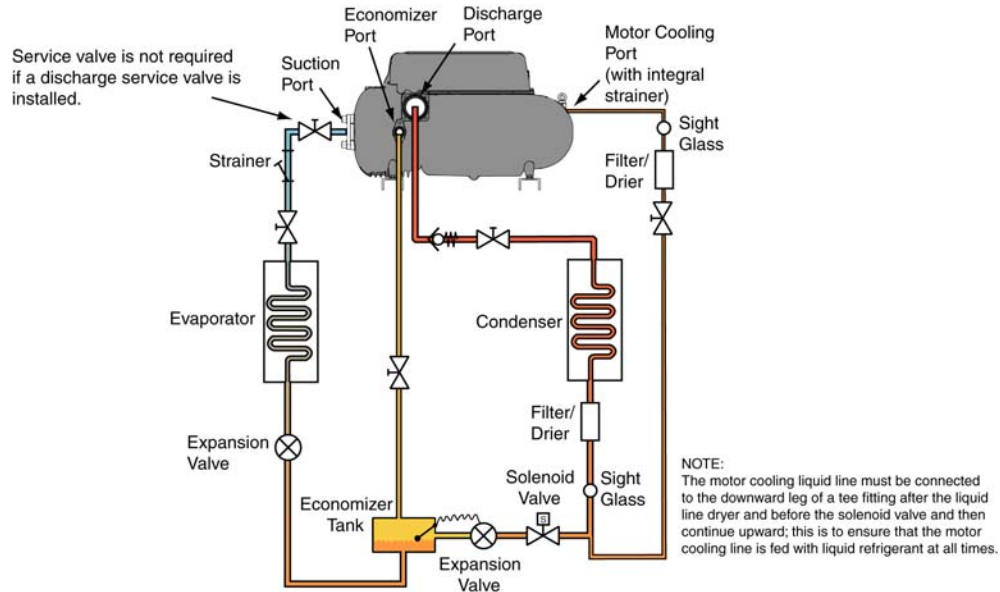
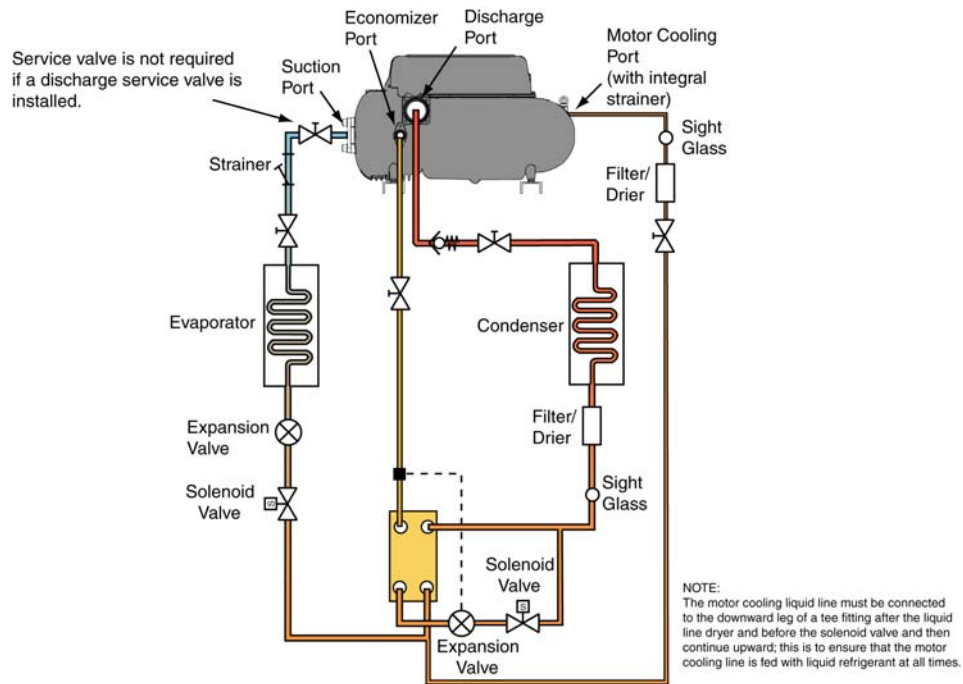

Figure D-1



Typical Refrigeration Piping Schematic with Flash Tank Economizer

Figure D-2



Typical Refrigeration Piping Schematic with Sub-cooler Circuit Economizer

Figure D-3

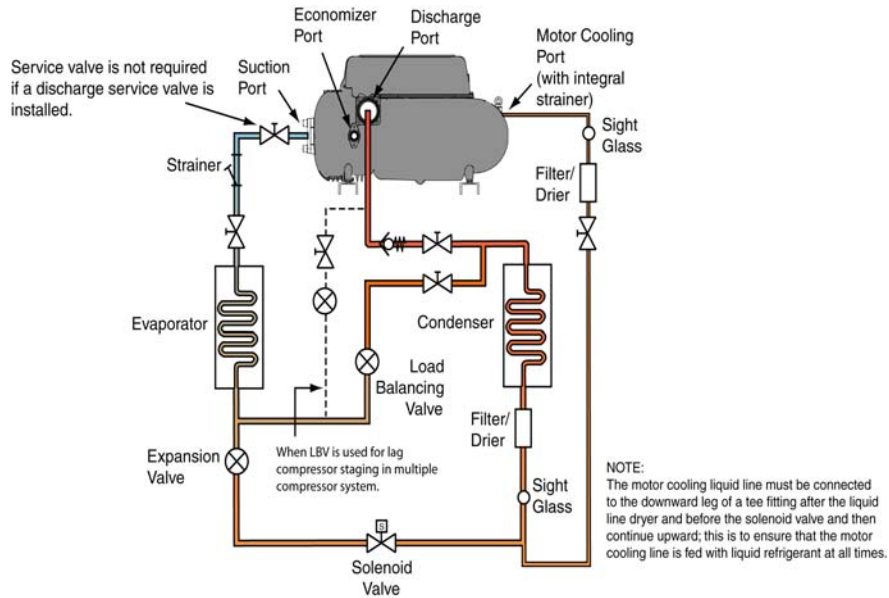

Typical Refrigeration Piping Schematic with Load Balancing Valve (for systems without a distributor)

Figure D-4

NOTE:

It is recommended to use proper distributors with auxiliary side connections such as Sporlan 1650R Series.

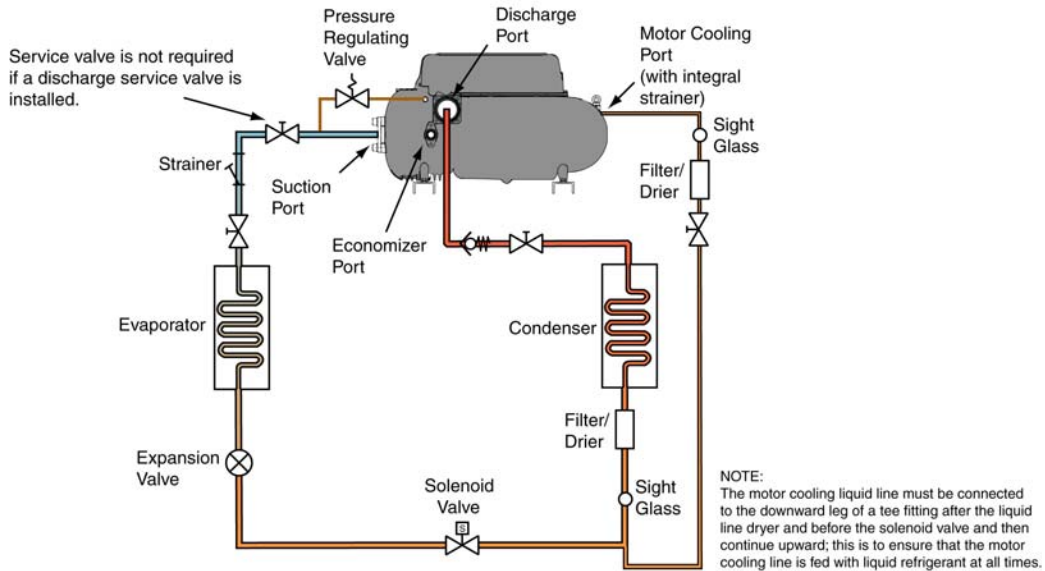

Typical Refrigeration Piping Schematic using Motor-cooling Pressure-regulating Valve for Medium Temperature Applications

Figure D-5

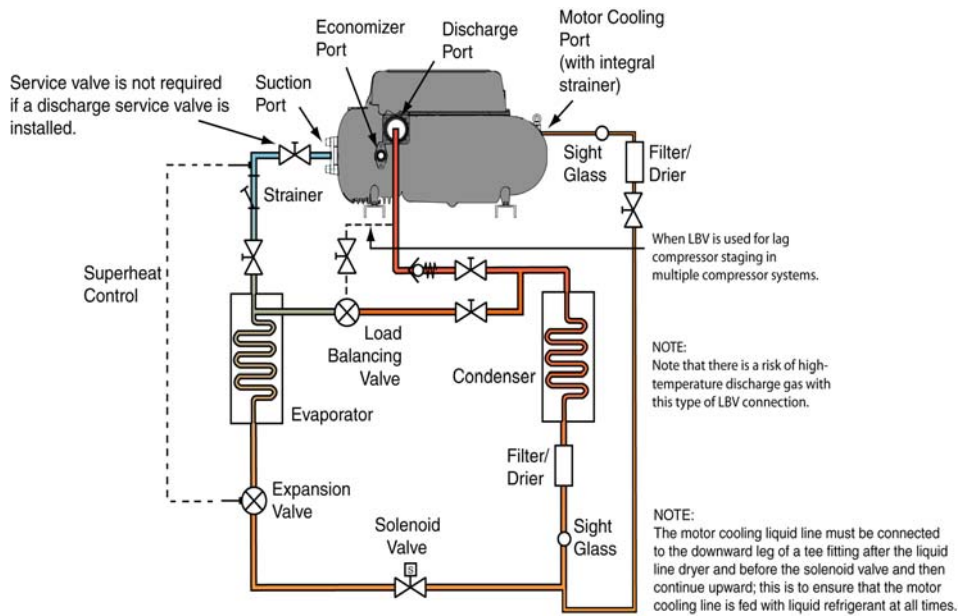

Typical Refrigeration Piping Schematic with Load Balancing Valve
(DX coils fitted with a distributor)

Figure D-6

NOTE:

It is recommended to use proper distributors with auxiliary side connections such as Sporlan 1650R Series and connect the load balance valve as per Figure D-4.

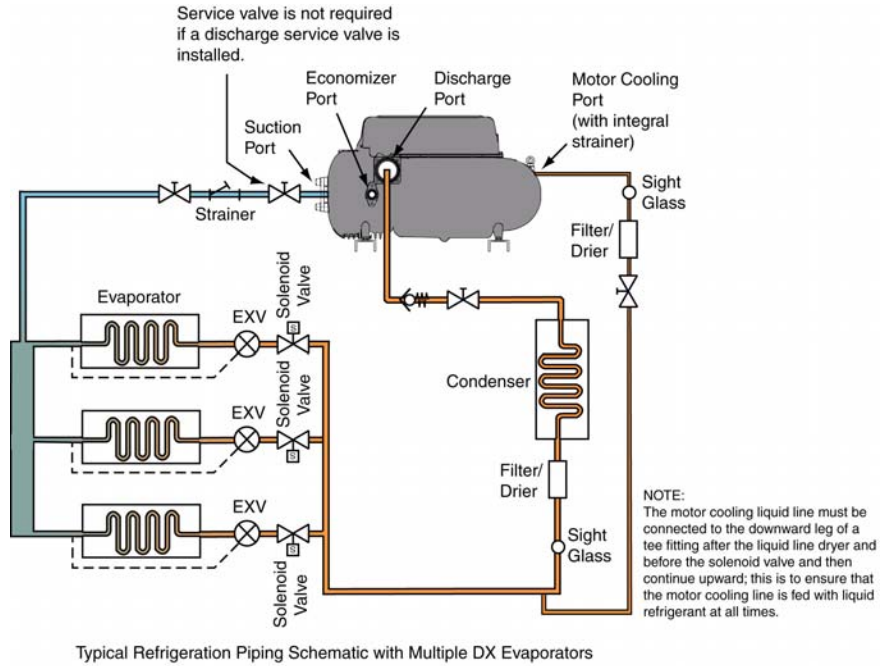
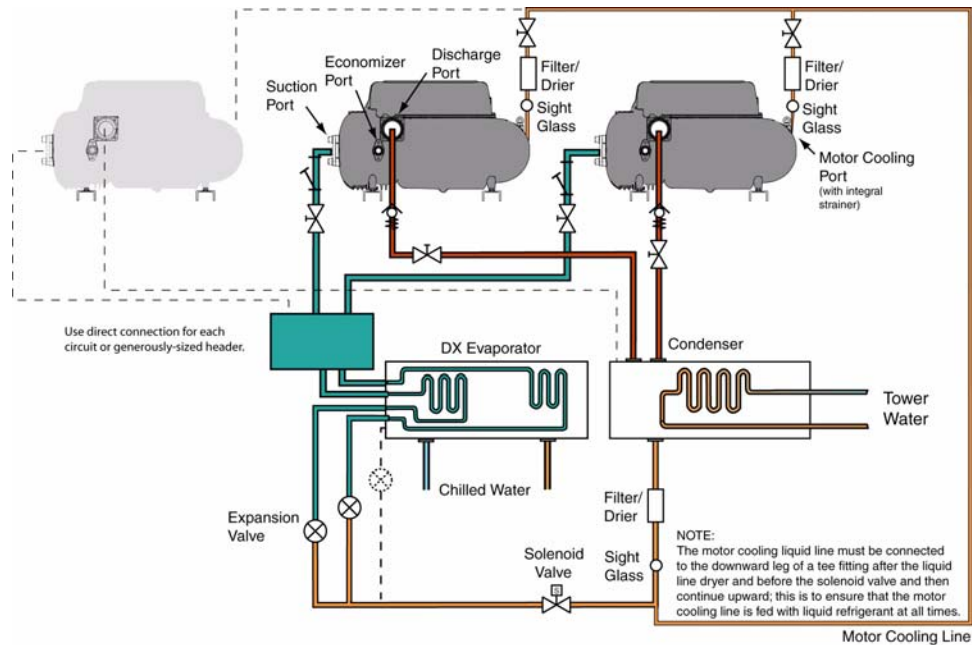

Figure D-7



Typical Refrigeration Piping Schematic Using Multiple Compressors on a Common Circuit With a DX Evaporator

Figure D-8

NOTE:
Contact Danfoss Turbocor for compressor selection and technical advice.

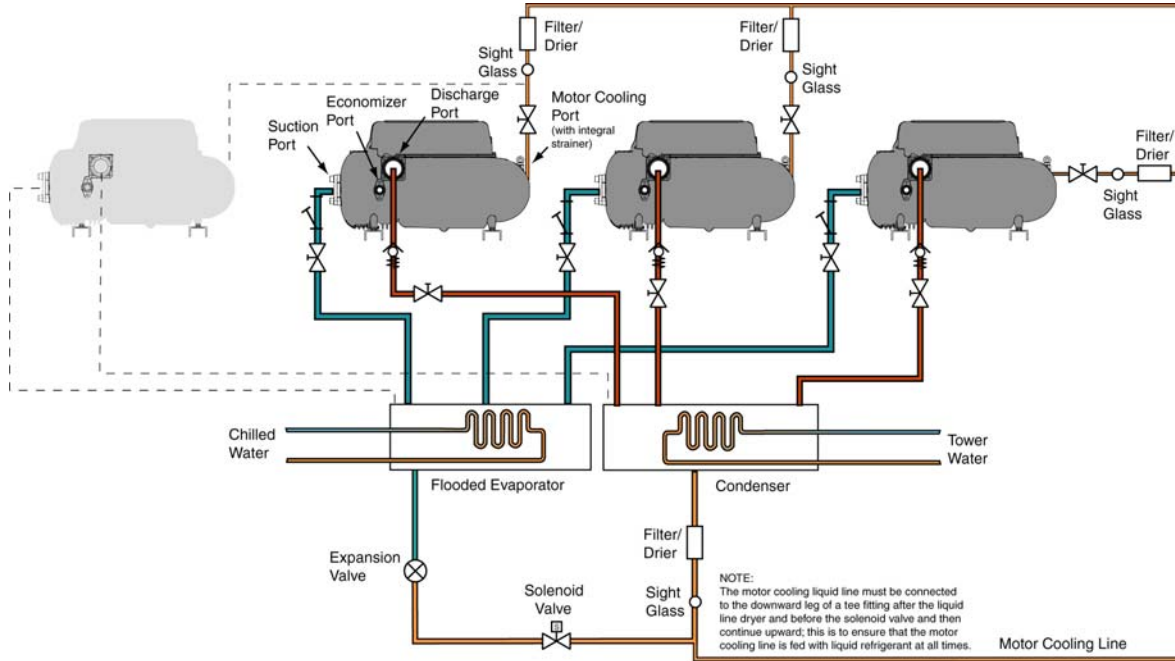

Typical Refrigeration Piping Schematic Using Multiple Compressors on a Common Circuit With a Flooded Evaporator

Figure D-9

NOTE:
Contact Danfoss Turbocor for compressor selection and technical advice.

Appendix E: Accessory Specifications

Suction Service Valve (TT300)

- Inlet size: 3-1/8"
- Materials:
 - Flange: Brass
 - Ball: Stainless steel
 - Seal: Teflon
 - Pipe: Copper
- UL/cUL listed and meets CE requirements (PED 97/23/EC)
- Tested per UL 1995, Section 61A for 700 psig working pressure
- Compatible with R134a and R22 refrigerants
- Fastening torque: 75 Nm.
- Weight: 11.75 kg (25.85 lbs)



Ordering Info

Suction Valve Kit	Part No. 100412	Kit includes one 3-1/8" suction valve with o-ring, lubrication, attaching hardware (four sets of M16 x 45 HTS screws and spring washers).
-------------------	-----------------	---

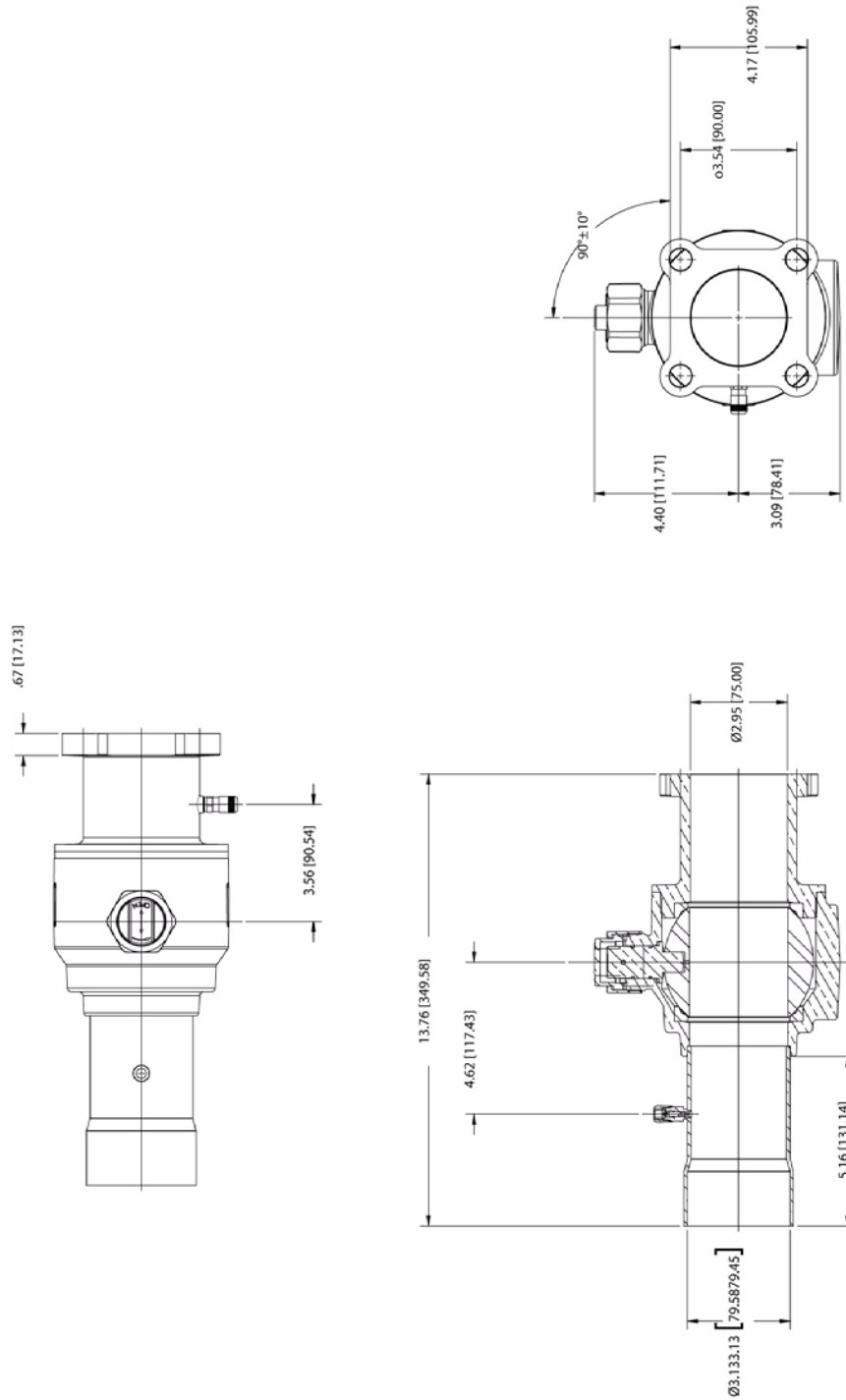

Suction Flange (TT400)

- Inlet size: 3"
- Design pressure rating: 1890 kPa (274 psi)
- Compatible with R134a and R22 refrigerant
- Materials: Steel
- Fastening torque: 75 Nm.
- Weight: 2.3 kg (5 lbs)

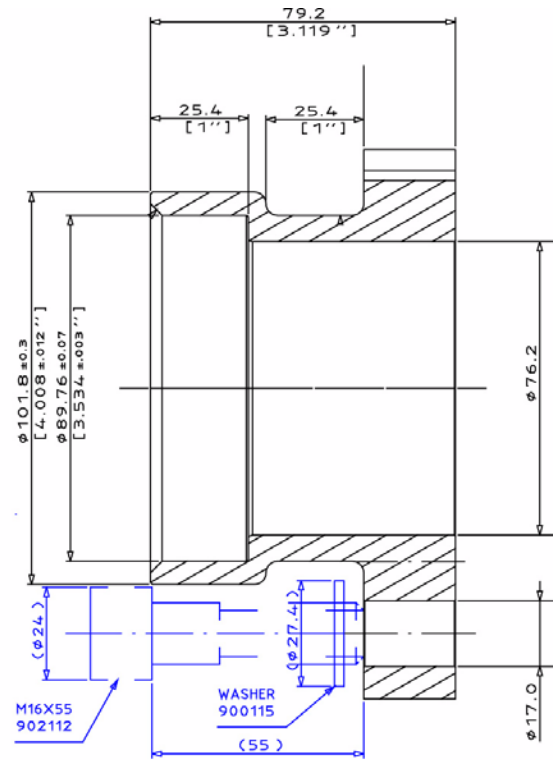
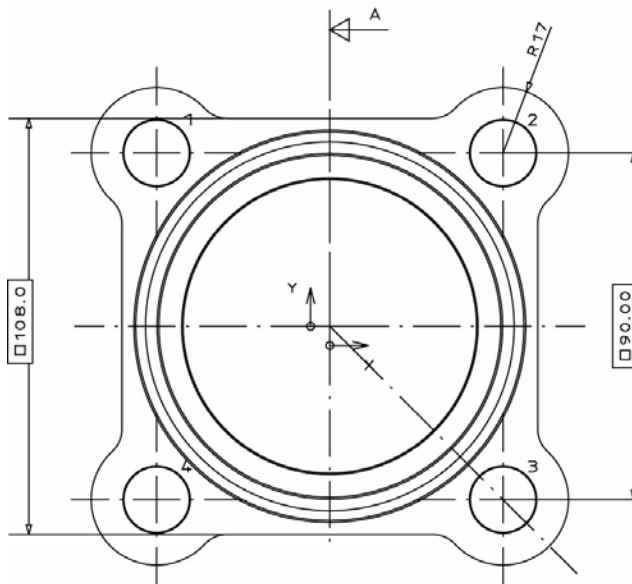

Section view A-A

Ordering Info

Suction Flange Kit	Part No. 100151	Kit includes one 3" flange, o-ring, lubrication, attaching hardware (four sets of M16 x 45 HTS screws and spring washers).
--------------------	-----------------	--

Discharge Service/Non-return Valve (TT300)

- Outlet size: 2-1/8"
- Integral, spring-loaded non-return valve
- Materials:
 - Flange: Brass
 - Ball: Stainless steel
 - Seal: Teflon
 - Pipe: Copper
 - Non-return valve (R134a): Delrin poppet, o-ring, and steel spring
 - Non-return valve (R22): Tedur poppet, o-ring, and steel spring
- UL/cUL listed and meets CE requirements (PED 97/23/EC)
- Tested per UL 1995, Section 61A for 700 psig working pressure
- Fastening torque: 22 Nm.
- Weight: 4.85 kg (10.68 lbs)



Ordering Info

Discharge Service/Non-return Valve Kit (R134a)	Part No. 100413	Kit includes one 2-1/8" discharge valve with integral non-return valve, o-ring, lubrication, attaching hardware (four sets of M10 x 30 HTS screws and spring washers).
Discharge Service/Non-return Valve Kit (R22)	Part No. 100513	Kit includes one 2-1/8" discharge valve with integral non-return valve, o-ring, lubrication, attaching hardware (four sets of M10 x 30 HTS screws and spring washers).

Discharge Flange

- Inlet size: 2-1/8"
- Design pressure rating: 1890 kPa (274 psi)
- Compatible with R134a and R22 refrigerant
- Materials: Brass
- Fastening torque: 22 Nm.
- Weight: 1.8 kg (4 lbs)

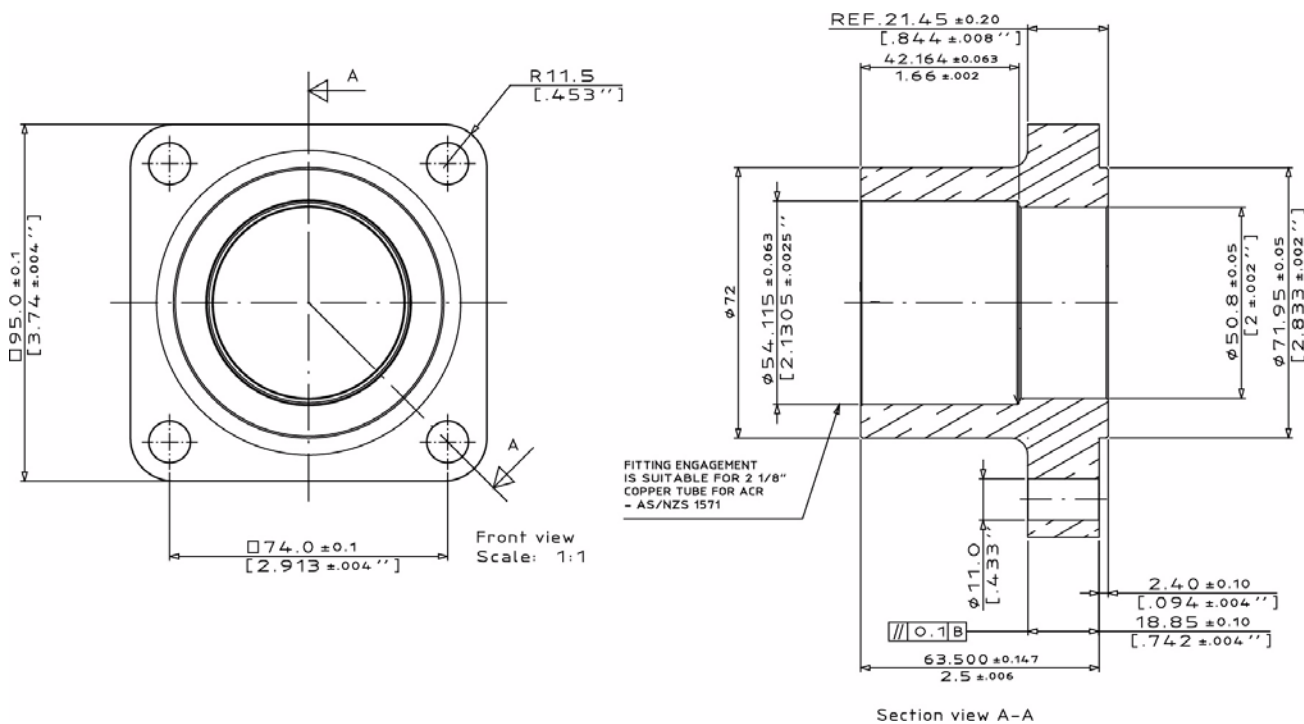
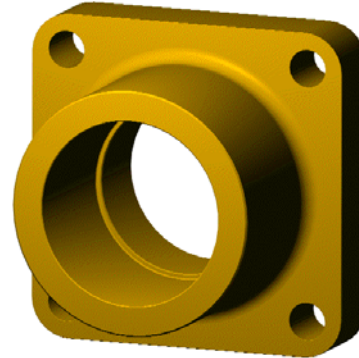

Ordering Info

Discharge Flange Kit	Part No. 100152	Kit includes one 2-1/8" flange, o-ring, lubrication, attaching hardware (four sets of M10 x 30 HTS screws and spring washers).
----------------------	-----------------	--

Discharge Flange (TT400)

- Inlet size: 2-1/8"
- Design pressure rating: 1890 kPa (274 psi)
- Compatible with R134a and R22 refrigerant
- Materials: Steel
- Fastening torque: 22 Nm.
- Weight: 1.1 kg (2.4 lbs)

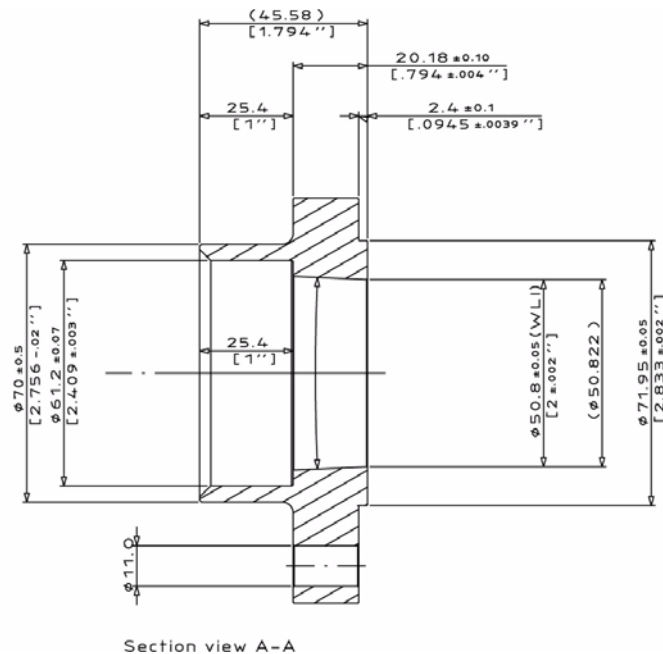
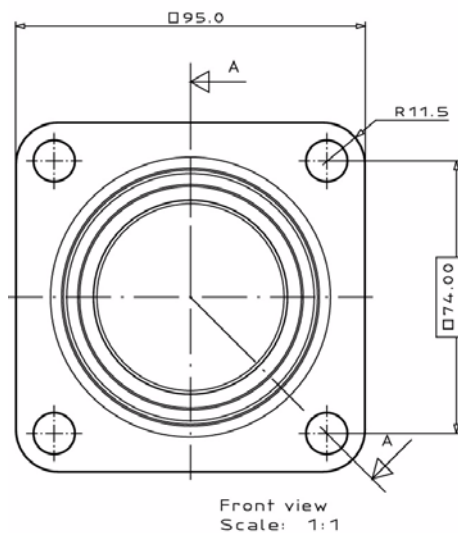

Ordering Info

Discharge Flange Kit	Part No. 100153	Kit includes one 2-1/8" flange, o-ring, lubrication, attaching hardware (four sets of M10 x 30 HTS screws and spring washers).
----------------------	-----------------	--

Discharge Flange/Non-return Valve (TT300)

- Inlet size: 2-1/8"
- Design pressure rating: 1890 kPa (274 psi)
- Materials:
 - Flange: Brass
 - Non-return valve (R134a): Delrin poppet, o-ring, and steel spring
 - Non-return valve (R22): Tedur poppet, o-ring, and steel spring
- Fastening torque: 22 Nm.
- Weight: 1.8 kg (4 lbs)



NOTE:

Follow proper pipe brazing guidelines. Remove the plastic poppet or use a wet rag to keep the flange cool.

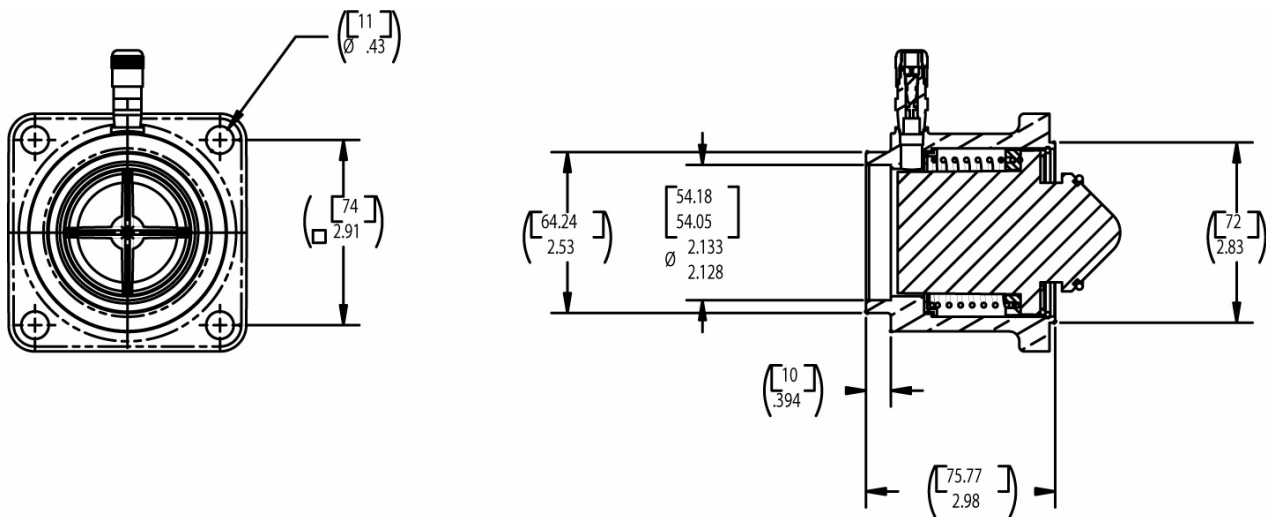

Ordering Info

Discharge Flange/Non-return Valve Kit (R134a)	Part No. 100479	Kit includes one 2-1/8" non-return valve, o-ring, lubrication, attaching hardware (four sets of M10 x 30 HTS screws and spring washers).
Discharge Flange/Non-return Valve Kit (R22)	Part No. 100579	Kit includes one 2-1/8" non-return valve, o-ring, lubrication, attaching hardware (four sets of M10 x 30 HTS screws and spring washers).

Suction Flange

- Inlet size: 3-1/8"
- Design pressure rating: 1890 kPa (274 psi)
- Compatible with R134a and R22 refrigerants
- Materials: Brass
- Fastening torque: 75 Nm.
- Weight: 1.7 kg (3.75 lbs)

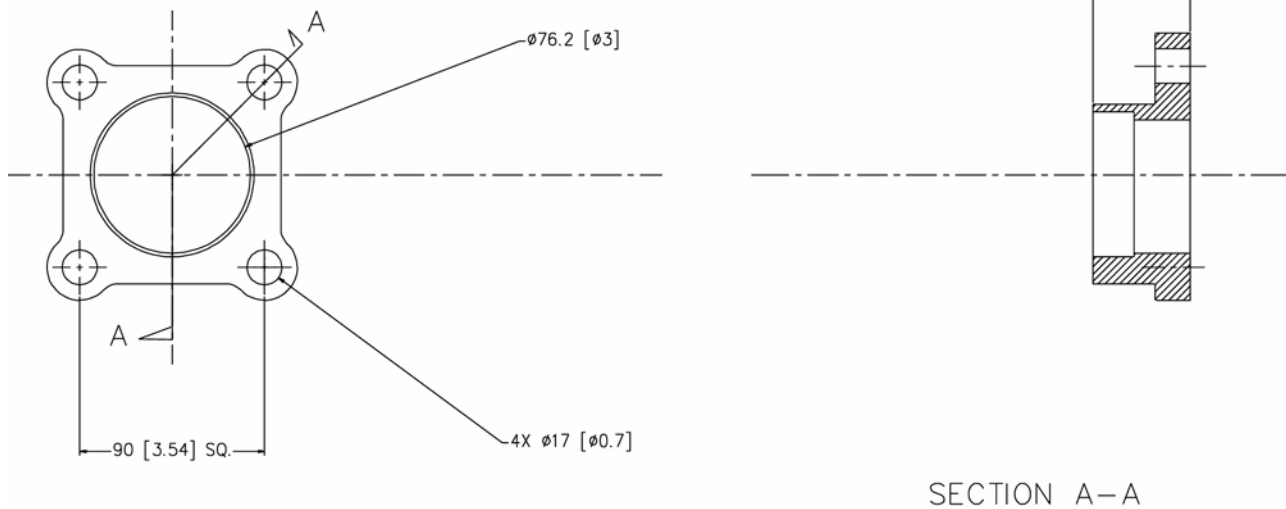

Ordering Info

Suction Flange Kit	Part No. 100402	Kit includes one 3-1/8" flange, o-ring, lubrication, attaching hardware (four sets of M16 x 45 HTS screws and spring washers).
--------------------	-----------------	--

Economizer Service Valve (TT300)

- Inlet size: 7/8"
- Design pressure rating: 1890 kPa (274 psi)
- Materials:
 - Body: Brass
 - Ball: Stainless steel
 - Seal: Teflon
 - Pipe: Copper
- Fastening torque: 22 Nm
- Weight: 0.77 kg (1.69 lbs)

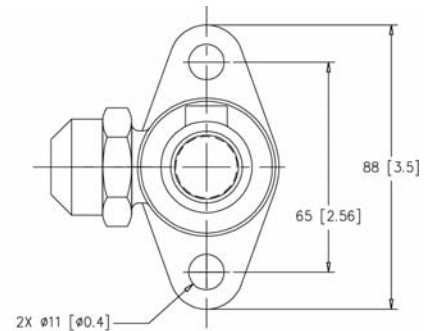
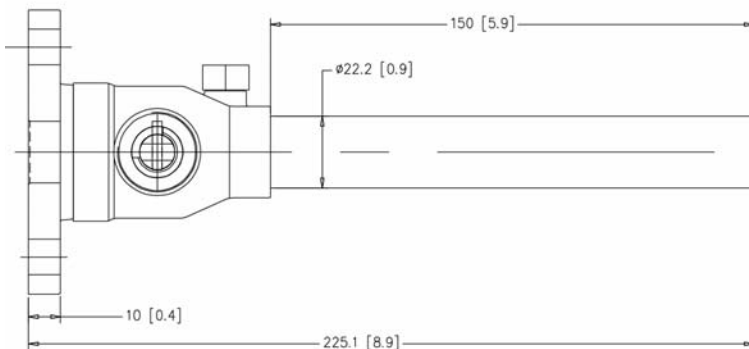

IMPORTANT: Refer to Technical Bulletin PSS-00059B for revised dimensions of the copper pipe.

Ordering Info

Economizer Valve Kit	Part No. 100014	Kit includes one 7/8" economizer valve, o-ring, lubrication, attaching hardware (two sets of M10 x 30 HTS screws and spring washers).
----------------------	-----------------	---

Economizer Flange

- Inlet size: 7/8"
- Design pressure rating: 1890 kPa (274 psi)
- Compatible with R134a and R22 refrigerants
- Materials: Brass
- Fastening torque: 22 Nm.
- Weight: 0.35 kg (0.75 lbs)

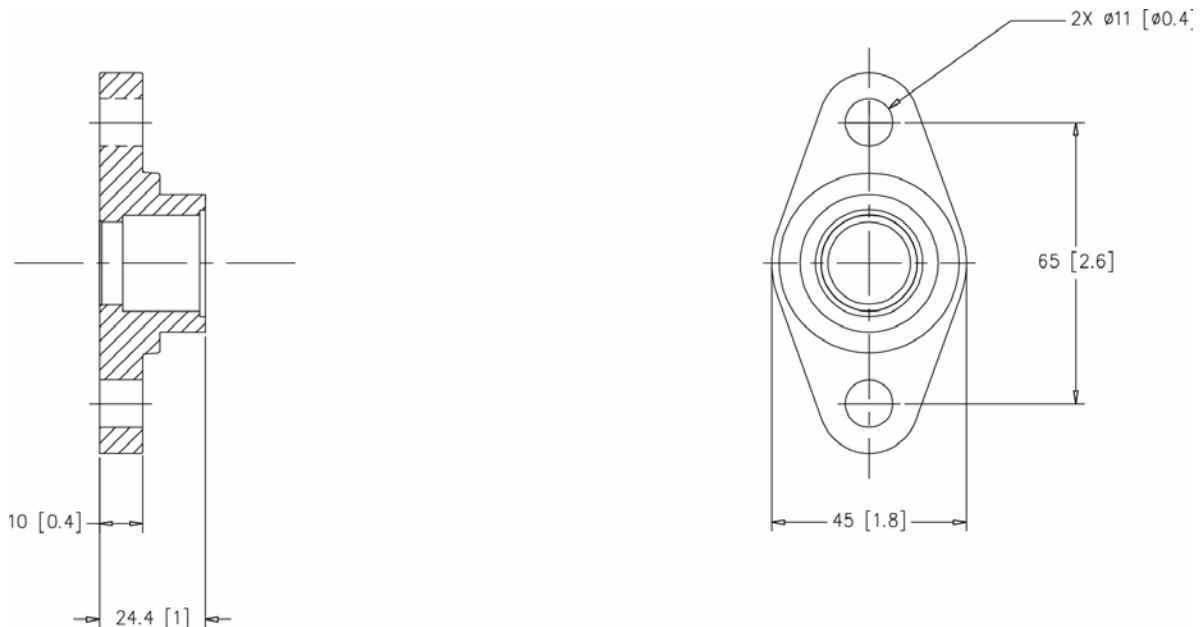

Ordering Info

Economizer Flange Kit	Part No. 100400	Kit includes one 7/8" flange, o-ring, lubrication, attaching hardware (two sets of M10 x 30 HTS screws and spring washers).
-----------------------	-----------------	---

Line Reactor 140A (10% impedance, TT300 only)

- Type: dry, air-cooled, open terminals
- Manufactured to standard: UL508
- Phase/Frequency: 3-phase/ 60 Hz
- Supply voltage: 480Vac (600V Max.)
- Rated current: 140A
- Inductance: 0.50mH \pm 10%
- Flux density @ rated current: <1.6 tesla
- Core type: high permeability silicon, non-grain-oriented (N.G.O.), laminated core
- Cooling type: air-cooled
- Q factor at rated current, 60 Hz: approx. 22
- Insulation class: H-220
- Dielectric strength tested @: 2.2kVac for 1 minute according to UL508
- Total losses, basic current: approx. 500 W
- Temp rise @ rated current: <155°C (<279°F)
- Dimensions: 229H x 279W x 236D (in mm)
9H x 11W x 9.3D (in inches)

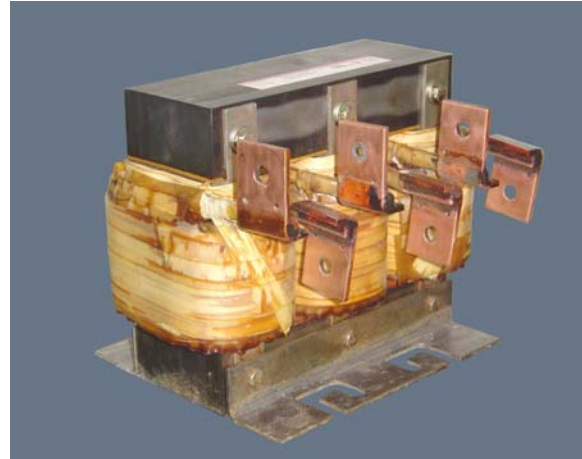

- Mass: 43 kg (95 lbs)
- Impregnation: dip and bake process to varnish, class H insulation standard
- Terminals: copper bus bar, hole to suit M8 bolt

NOTE:

Order this part number when line reactor is used in conjunction with Harmonic Filter.

Ordering Info

Line Reactor 140A	Part No. 901453	Kit includes installation instructions.
-------------------	-----------------	---

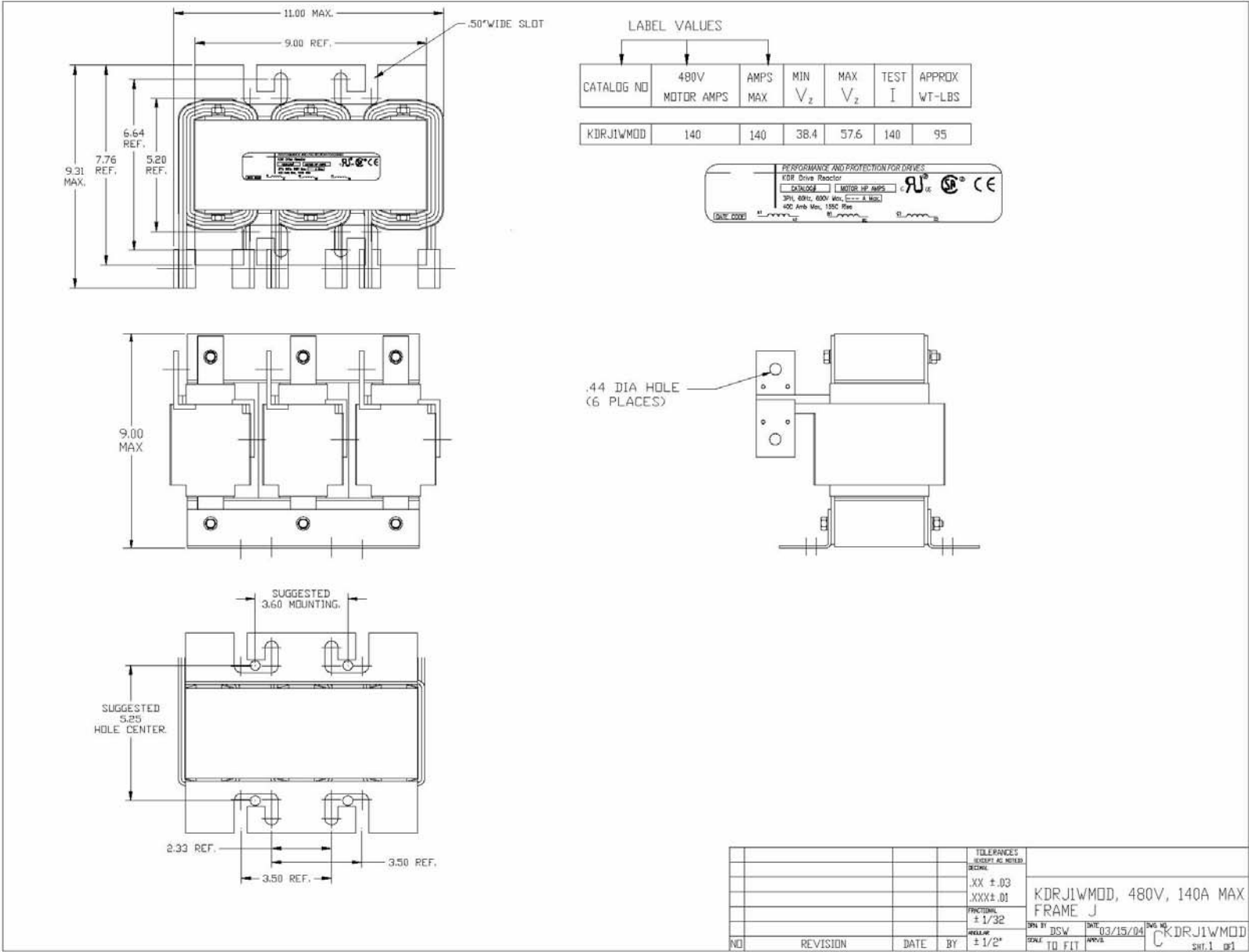

Line Reactor 140A (5% impedance, TT300 only)

- Type: dry, air-cooled, open terminals
- Agency approvals:
Manufactured to UL Standard 508
UL recognized to file # E116124
CSA certified - LR86011
CE marked
- Phase/Frequency: 3-phase/ 60 Hz
- Supply voltage: 480Vac (600V Max.)
- Rated current: 140A
- Inductance: 0.202mH $\pm 20\%$
- Percent impedance @ rated current: 5% $\pm 20\%$
- Flux density @ rated current: 15 kG
- Core type: high permeability silicon, non-grain-oriented (N.G.O.), laminated core steel
- Cooling type: air-cooled
- Q factor at rated current, 60 Hz: approx. 25
- Insulation class: H-220
- Dielectric strength tested @: 2.2kVac for 1 minute according to UL508
- Total losses @ rated current: 274 W
- Ambient temp max.: 40°C (104°F)
- Temp rise @ rated current: <155°C (<279°F)



- Dimensions: 229H x 279W x 203D (in mm)
9H x 11W x 8D (in inches)
- Weight: 25 kg (55 lbs)
- Impregnation: dipped and baked with 100% solids epoxy polymer
- Terminals: copper bus bar with 11mm (0.34") diameter hole

Ordering Info

Line Reactor 140A	Part No. 901974	Kit includes installation instructions.
-------------------	-----------------	---

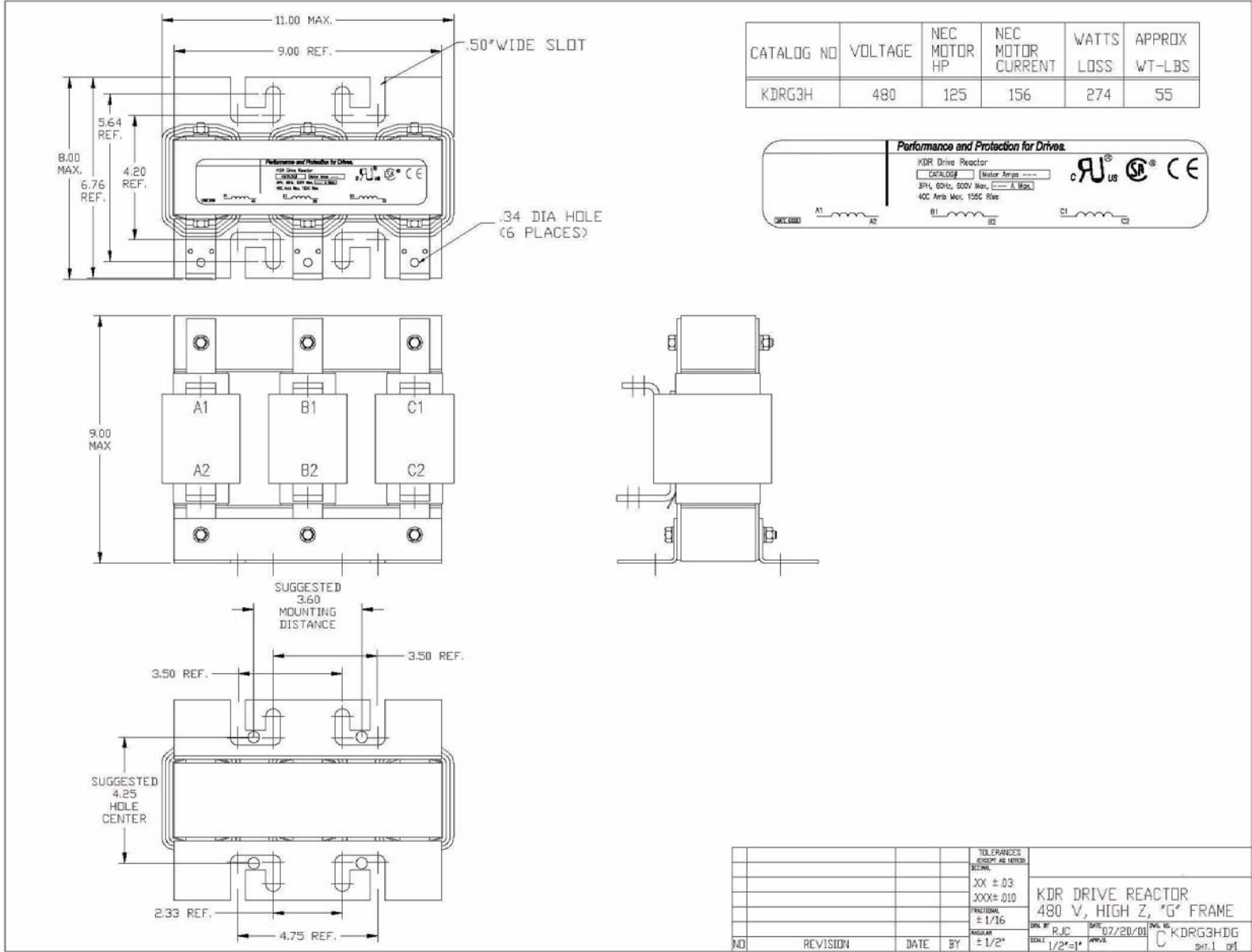

Line Reactor 180A (10% impedance)

- Type: dry, air-cooled, open terminals
- Manufactured to standard: UL508
- Phase/Frequency: 3-phase/ 60 Hz
- Supply voltage: 480Vac (600V Max.)
- Rated current: 180A
- Inductance: 0.50mH \pm 10%
- Flux density @ rated current: <1.7 tesla
- Core type: high permeability silicon, non-grain-oriented (N.G.O.), laminated core
- Cooling type: air-cooled
- Q factor at rated current, 60 Hz: approx. 20
- Insulation class: H - 220
- Dielectric strength tested @: 2.2kVac for 1 minute according to UL508
- Total losses, basic current: approx. 775 W
- Temp rise @ rated current: <155°C (<279°F)
- Dimensions: 317H x 376W x 236D (in mm)
12.5H x 14.8W x 9.3D (in inches)

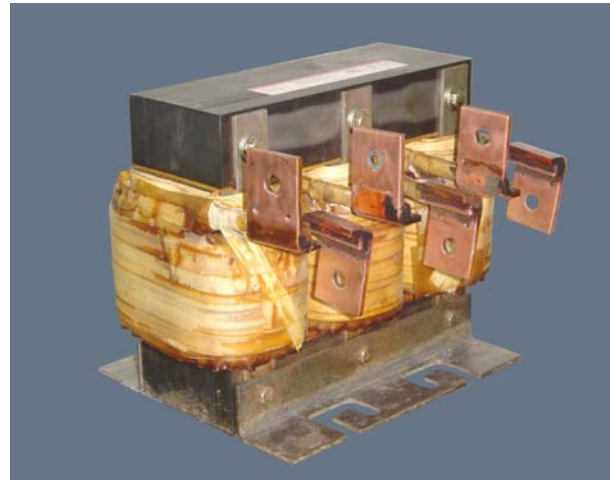

- Mass: 57 kg (125 lbs)
- Impregnation: dip and bake process to varnish, class H
- Terminals: copper bus bar, hole to suit M8 bolt

NOTE:

Order this part number when line reactor is used in conjunction with Harmonic Filter.

Ordering Info

Line Reactor 180A	Part No. 901454	Kit includes installation instructions.
-------------------	-----------------	---

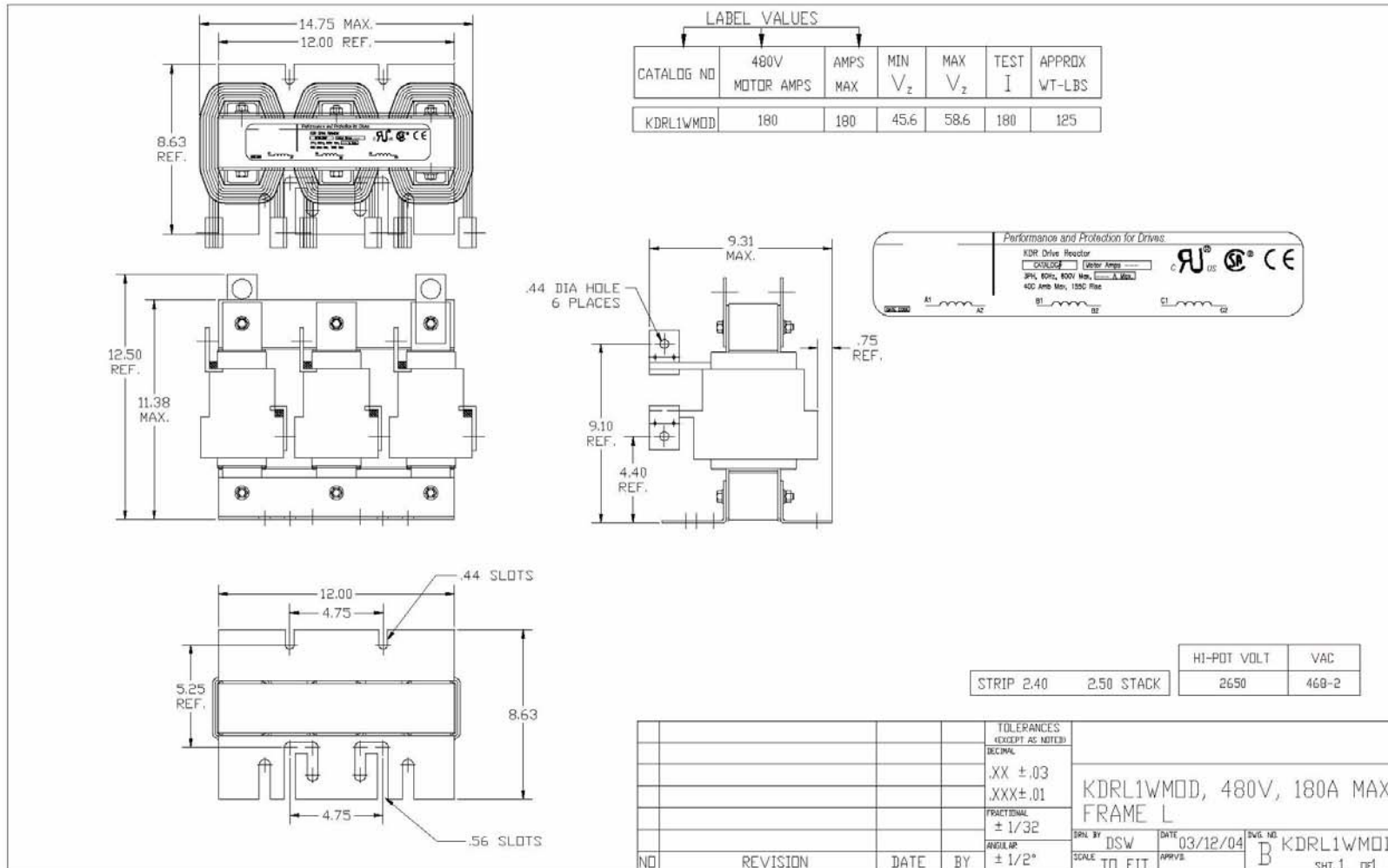

Line Reactor 180A (5% impedance)

- Type: dry, air-cooled, open terminals
- Agency approvals:
 Manufactured to UL Standard 508
 UL recognized to file # E116124
 CSA certified - LR86011
 CE marked
- Phase/Frequency: 3-phase/ 60 Hz
- Supply voltage: 480Vac (600V Max.)
- Rated current: 180A
- Inductance: 0.172mH $\pm 10\%$
- Percent impedance @ rated current: 5% $\pm 20\%$
- Flux density @ rated current: 15 kG
- Core type: high permeability silicon, non-grain-oriented (N.G.O.), laminated core steel
- Cooling type: air-cooled
- Q factor at rated current, 60 Hz: approx. 28
- Insulation class: H-220
- Dielectric strength tested @: 2.2kVac for 1 minute according to UL508
- Total losses @ rated current: 274 W
- Ambient temp max.: 40°C (104°F)
- Temp rise @ rated current: <155°C (<279°F)



- Dimensions: 229H x 279W x 203D (in mm)
 9H x 11W x 8D (in inches)
- Weight: 25 kg (55 lbs)
- Impregnation: dipped and baked with 100% solids epoxy polymer
- Terminals: copper bus bar with 11mm (0.44") diameter hole

Ordering Info

Line Reactor 180A	Part No. 901975	Kit includes installation instructions.
-------------------	-----------------	---

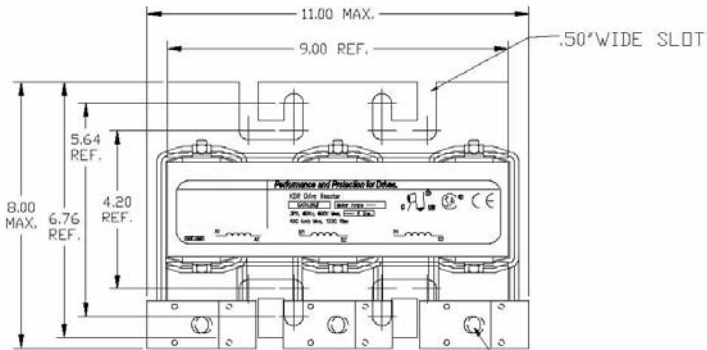

CATALOG NO	VOLTAGE	NEC MOTOR HP	NEC MOTOR CURRENT	WATTS LOSS	APPROX WT-LBS	TORQUE (LB-IN)
KDRG1H	480	150	180	359	60	--

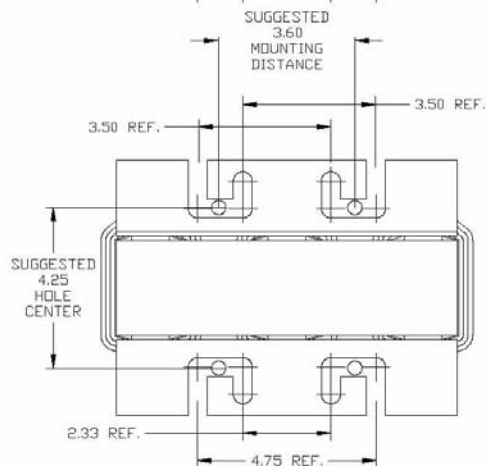
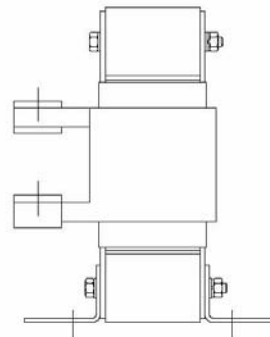
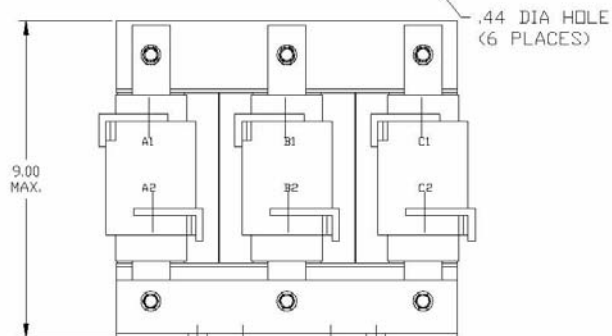

NO	REVISION	DATE	BY	TOLERANCES UNLESS AS NOTED	SCALE	DATE	APPROV	DWG NO
				DECIMAL				
				.XX ± .03				
				.XXX ± .010				
				FRACTIONS				
				± 1/16				
				ANGULAR				
				± 1/2°				
					1/2"=1"	07/30/01		KDRG1HDG
								SHT. 1 of 1

Suction Strainer (TT300)

- Inlet/outlet size: 3-1/8"
- Design pressure rating: 1890 kPa (274 psi)
- Compatible with R134a and R22 refrigerants
- Materials:
 - Body: Brass and copper
 - Strainer: Stainless steel mesh
- Fastening torque: 75 Nm.
- Weight: 3.5 kg (7.68 lbs)

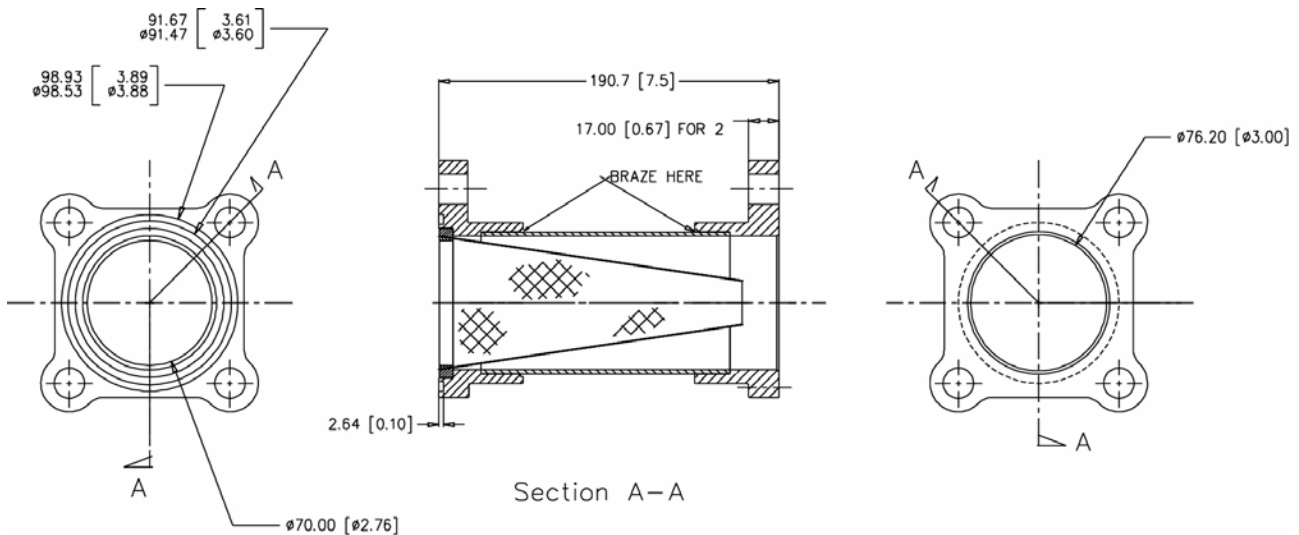
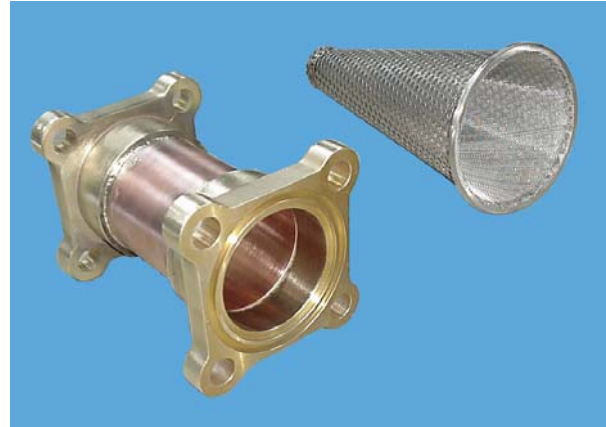

Ordering Info

Suction Strainer	Part No. 100472	Kit includes one conical mesh strainer, 3-1/8" strainer housing, o-ring, lubrication, and attaching hardware (four sets of M16 x 45 HTS screws and spring washers, and four sets of M16 x 65 HTS screws, spring washers, and nuts),
------------------	-----------------	---

EMI/EMC Filter (UL)

- Approved to UL 1283
- Designed to comply to EN 133200. CSA 22.2 No. 8
- Rated voltage: 480VAC max., 50/60Hz
- Rated current:
 - 185A @ 40°C operating ambient temp.
 - 165A @ 50°C operating ambient temp.
- Power dissipation @ rated current: 20W max
- Max leakage current each line to ground:
 - 90mA @ 250VAC 60Hz
 - 180mA @ 480VAC 60Hz
- Humidity range: 0-95% R.H.
- Weight: 20 lbs max



Ordering Info

EMI Filter (UL) 185A	Part No. 901665	Kit includes installation instructions.
----------------------	-----------------	---

SCHEMATIC DIAGRAM

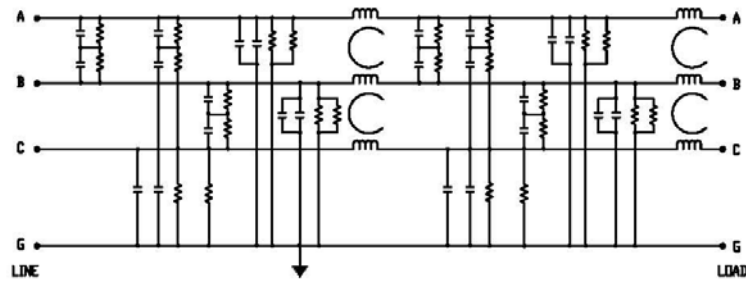

NOTE: TORQUE WIRE LUGS TO 150 LB-IN

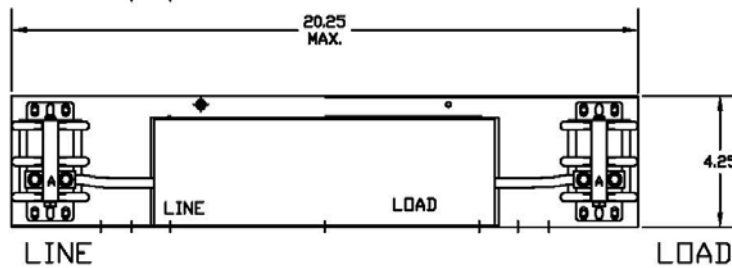
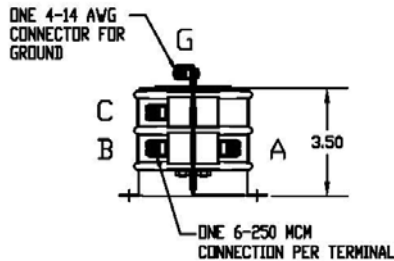
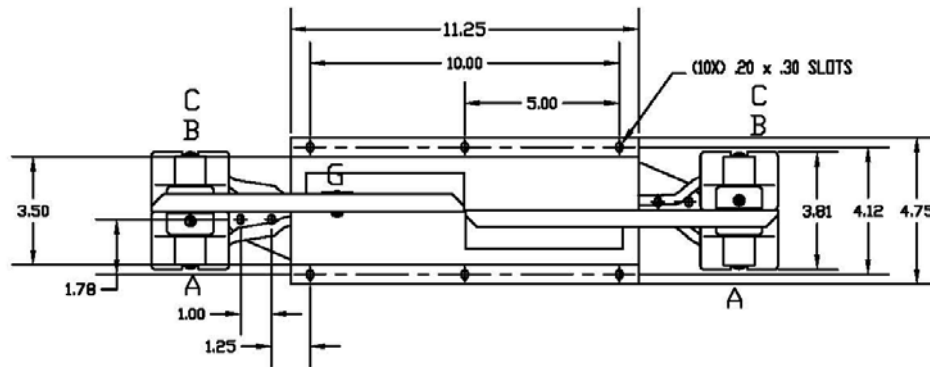

MINIMUM INSERTION LOSS 50 Ω CIRCUIT			
COMMON MODE		DIFFERENTIAL MODE	
mHz	min. I.L. (dB)	mHz	min. I.L. (dB)
.01		.01	
.05		.05	
.15	60	.15	30
0.5	60	0.5	35
1.0	60	1.0	35
5.0	60	5.0	30
10	50	10	30
30	40	30	20
100		100	

TEST SPECIFICATIONS

WEIGHT: 20 LBS MAX.

POWER DISSIPATION @ RATED CURRENT: 20W MAX

DESIGNED TO COMPLY TO EN 133200. CAN NO.8
APPROVED TO UL 1283

MAX LEAKAGE CURRENT EACH LINE TO GROUND
90 mA AT 250 VAC 60 Hz
180 mA AT 480 VAC 60 Hz

HI-POT(1 MIN) HI-POT(1 MIN)
L/G 2210 VDC A-G, B-G, C-G (3 TESTS).
L/L 2780 VDC A-B, B-C, A-C, (3 TESTS).

RATED VOLTAGE: 480VAC MAX, 50/60Hz (3-PHASE)
RATED CURRENT AT: 480VA, 185A
MAX OPERATING AMBIENT TEMPERATURE AT RATED CURRENT: 40°C
HUMIDITY RANGE: 0-95% R.H.
PATENT #6218913

(REV 2)

				TOLERANCES UNLESS OTHERWISE SPECIFIED	
				XX ± .03	KRF185APT 185 AMP, 3PH, 480V RFI
				XXX ± .01	
				± 1/32	
				± 1/2"	
NO	REVISION	DATE	BY	± 1/2"	DESIGNED BY DSV DRAWN BY 3/8"=1" DATE 02-01-02 PART NO C KRF185APT SHEET 1 OF 1

EMI/EMC Filter (CE)

- Approved to UL 1283
- Designed to comply to EN 133200. CSA 22.2 No. 8
- Rated voltage: 480VAC max., 50/60Hz
- Rated current:
 - 185A @ 40°C operating ambient temp.
 - 165A @ 50°C operating ambient temp.
- Power dissipation @ rated current: 20W max
- Max leakage current each line to ground:
 - 150mA @ 250VAC 60Hz
 - 300mA @ 480VAC 60Hz
- Insulation resistance: 1000M ohms min. @ 250VDC
- Humidity range: 0-95% R.H.
- Weight: 20 lbs max



Ordering Info

EMI Filter (CE) 185A	Part No. 901666	Kit includes installation instructions.
----------------------	-----------------	---

MINIMUM INSERTION LOSS		50 Ω CIRCUIT	
COMMON MODE		DIFFERENTIAL MODE	
mHz	min. IL (dB)	mHz	min. IL (dB)
.01		.01	
.05		.05	
.15	80	.15	35
0.5	95	0.5	45
1.0	100	1.0	35
5.0	100	5.0	45
10	95	10	40
30	80	30	25
100		100	

TEST SPECIFICATIONS

WEIGHT: 20 LBS MAX.

POWER DISSIPATION @ RATED CURRENT: 20W MAX

DESIGNED TO COMPLY TO EN 133200. CAN 22.2 NO.8 AND UL 1283

MAX LEAKAGE CURRENT EACH LINE TO GROUND
 150 mA AT 250 VAC 60 Hz
 300 mA AT 480 VAC 60 Hz

HI-POT(1 MIN) HI-POT(1 MIN)
 L/G 2210 VDC A-G, B-G, C-G (3 TESTS).
 L/L 2780 VDC A-B, B-C, A-C, (3 TESTS).

RATED VOLTAGE: 480VAC MAX, 50/60Hz (3-PHASE)
 RATED CURRENT AT: 480VAC, 185A
 MAX OPERATING AMBIENT TEMPERATURE AT RATED CURRENT: 40°C
 HUMIDITY RANGE: 0-95% R.H.
 INSULATION RESISTANCE: 1000 MEGOHMS MIN. AT 250VDC.

SCHEMATIC DIAGRAM

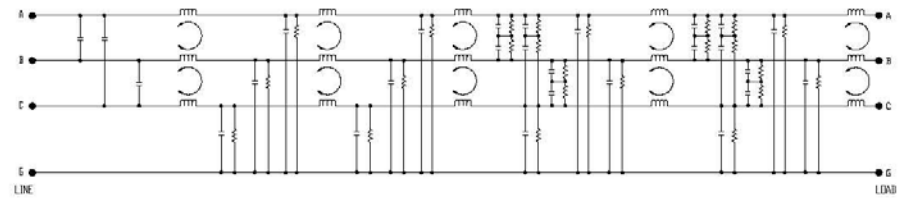

NOTE: TORQUE TERMINALS TO 50 IN-LBS MAX.

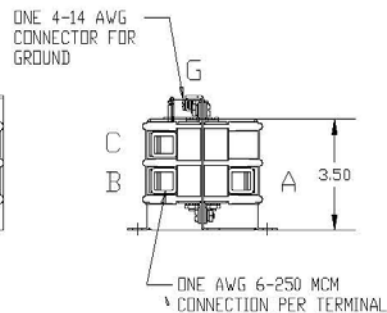
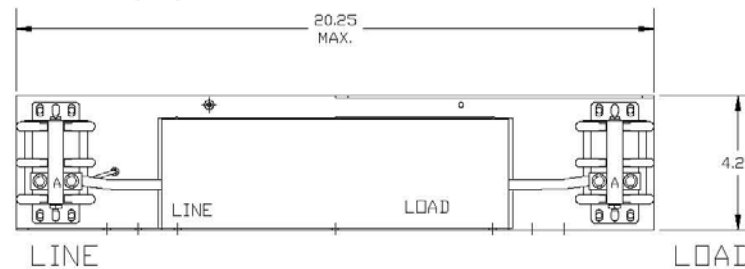
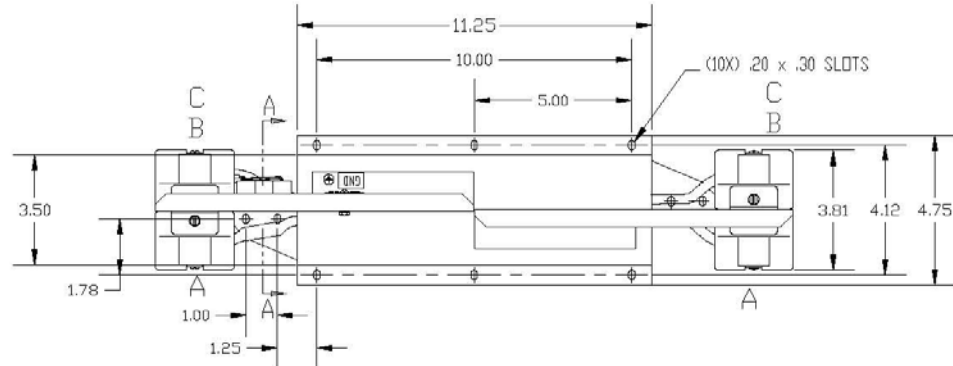
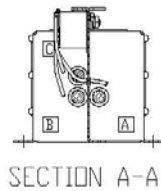

TOLERANCES UNLESS AS NOTED			
GENERAL	XX ± .03	KRF186APT 185 AMP, 3PH, 480V RFI	DWN BY DSW DATE 06/03/04 DWS NO 102195
	XXX ± .01		
FRACTIONAL	± 1/32		
REGULAR	± 1/2"	SCALE 3/8"=1"	REVISED C SHI.1 (P1)
NO	REVISION	DATE	BY

Harmonic Filter (TT300)

This filter reduces harmonic current in the AC power supply for Danfoss Turbocor compressors equipped with a line reactor.

- Rated Voltage: 480V
- Rated Frequency: 60Hz
- Max. Current of Compressor: 140A
- Total Harmonic Current Distortion: 12%
- Current Protection: Fuse
- Max. Operating Ambient Temperature: 40 °C.
- Humidity range: 0 - 95% R.H
- Enclosure: EN4SD242412GY
- Installation Type: Floor Mounted
- Dimensions: 610H x 610W x 305D (in mm)
24H x 24W x 12D (in inches)



Ordering Info

Harmonic Filter 480V	Part No. 901887	Kits include installation instructions.
----------------------	-----------------	---

Appendix F: Compressor Specifications

TT300 Sound Power Measurements

The sound power measurements for the TT300 have been established by CRIQ (Centre de Recherche Industrielle Quebec), which is ISO 9001 registered, certificate no. 008999. The Test Division is also accredited by the National Council of Canada, certificate no. 138.

- 250kW (70 ton) Refrigeration capacity
- 350kW (100 ton) Refrigeration capacity

Below are the results taken from the report "Sound Power Measurements on a Turbocor TT300 Compressor", file no. 29976.

The sound power levels on the TT300 compressor are measured in compliance with ISO 9614-1 (1993) and are given in decibels and in A-scale dB(A).

Two series of sound power measurements were performed on the unit while in two different modes:

Results

The sound power measured under each operational mode is presented in Table 1.

Table 1 Sound Power Measurements

Operation Mode	Sound Power (A-Scale)	Sound Power (Linear Scale)	Dominant Frequency
250 kW	81.5 dB(A)	81.5 dB(Lin)	1070 Hz
350 kW	86.0 dB(A)	85.5 dB(Lin)	1180 Hz

Table 2 presents the results of sound pressure calculations for various distances while the compressor is installed on top of a building.

Table 2 Sound Pressure Calculation

Distance in Relation to Compressor (meters)	Operational Mode of Compressor (Capacity)	
	250 kW (70 ton)	350 kW (100 ton)
1	72.5 dB(A)	78.0 dB(A)
2.5	65.5 dB(A)	70.0 dB(A)
5	59.5 dB(A)	64.0 dB(A)
8	55.5 dB(A)	60.0 dB(A)
30	43.0 dB(A)	48.5 dB(A)

Table 2 Sound Pressure Calculation

Distance in Relation to Compressor (meters)	Operational Mode of Compressor (Capacity)	
	250 kW (70 ton)	350 kW (100 ton)
100	32.5 dB(A)	38.0 dB(A)

Table 3 presents the results of sound power spectrum measurements for each operational mode.

Table 3 Sound Power Spectrum

Frequency	Operational Mode of Compressor			
	250 kW (70 ton)		350 kW (100 ton)	
64 Hz	38 dB(A)	48 dB(Lin)	38 dB(A)	48 dB(Lin)
125 Hz	48 dB(A)	57 dB(Lin)	54 dB(A)	60 dB(Lin)
250 Hz	48 dB(A)	55 dB(Lin)	53 dB(A)	57 dB(Lin)
500 Hz	48 dB(A)	51 dB(Lin)	54 dB(A)	56 dB(Lin)
1 kHz	56 dB(A)	56 dB(Lin)	58 dB(A)	58 dB(Lin)
2 kHz	52 dB(A)	51 dB(Lin)	56 dB(A)	55 dB(Lin)
4 kHz	54 dB(A)	52 dB(Lin)	57 dB(A)	56 dB(Lin)

TT400 Sound Power Measurements

The sound power measurements for the TT400 have been established by CRIQ (Centre de Recherche Industrielle Quebec), which is ISO 9001 registered, certificate no. 008999. The Test Division is also accredited by the National Council of Canada, certificate no. 138.

The sound power levels on the TT400 compressor are measured in compliance with ISO 9614-1 (1993) and are given in decibels and in A-scale dB(A).

The sound power measurements were performed under two sets of operating conditions:

- 422 kW (120 ton) refrigeration capacity
- 563 kW (160 ton) refrigeration capacity

Below are the results taken from the report "Acoustic Power Measurement on Turbocor TT400 Compressor", file no. 35709.

Results

Sound power measured with the discrete point method under two operational modes is presented in Table 1.

Table1 Sound Power Measurements

Operation Mode	Sound Power (A-Scale)	Sound Power (Linear Scale)
422 kW (120T)	88.4 dB(A)	89.1 dB(Lin)
563 kW (160T)	88.1 dB(A)	89.2 dB(Lin)

Table 2 presents the results of sound pressure calculations for various distances while the compressor is installed on top of a building.

Table2 Sound Pressure Calculation

Distance in relation to compressor (meters)	Noise level based on maximum power generated between 120 and 160 tons of refrigeration	
	dB(A)	dB(Lin)
1	81 dB(A)	82 dB(Lin)
1.5	77 dB(A)	78 dB(Lin)
3	71 dB(A)	72 dB(Lin)
5	68 dB(A)	69 dB(Lin)
30	52 dB(A)	53 dB(Lin)
100	41 dB(A)	42 dB(Lin)

Table 3 presents the results of sound intensity measurements for each operational mode.

Table3 Sound Power Spectrum

Frequency	Operational Mode of Compressor					
	422 kW (120 ton)		492 kW (140 ton)		563 kW (160 ton)	
125 Hz	42 dB(A)	60 dB(Lin)	39 dB(A)	54 dB(Lin)	45 dB(A)	61 dB(Lin)
250 Hz	55 dB(A)	61 dB(Lin)	52 dB(A)	60 dB(Lin)	55 dB(A)	62 dB(Lin)
500 Hz	58 dB(A)	59 dB(Lin)	55 dB(A)	58 dB(Lin)	58 dB(A)	59 dB(Lin)
1000 Hz	75 dB(A)	75 dB(Lin)	87 dB(A)	75 dB(Lin)	77 dB(A)	76 dB(Lin)
2000 Hz	70 dB(A)	69 dB(Lin)	67 dB(A)	67 dB(Lin)	68 dB(A)	68 dB(Lin)
4000 Hz	65 dB(A)	63 dB(Lin)	64 dB(A)	62 dB(Lin)	68 dB(A)	67 dB(Lin)

Index**A**

accessories, 1, 2-25

C

cable

- AC input - see specification, cable
- gland size, 13
- interface, 15

CE compliance, 9

certification, 1

Chiller Interface Module mounting, 16

compressor

- model nomenclature, 2-23
- part numbers, 2-23, 2-24
- sound data, 75
- weight, 28

contactor

- power line, 9

control wiring, 14

D

design guidelines, D-37

- application-specific requirements, D-39
- control requirements, D-38
- electrical requirements, D-38
- general requirements, D-37

dimensions

- compressor, B-28
- flanges, B-30, B-31, B-32, B-33
- mounting base, B-28

DIN rail, 17

discharge service/non-return valve kit, 2

disconnects, 8

drain holes, 18

E

earth connections, 11

economizer service valve kit, 2

environmental considerations, 18

ETL certification, 1

F

filter

- EMI/EMC, 2, 9
- harmonic, 2, 9

FLA, 12

flange kits, 2

G

guide specification

- compressor, 35

H

humidity, 18

I

isolation pads, 2

L

line protection, 9

line reactor, 2

LRA, 12

M

maximum current ratings, 12

motor cooling line, 17

mounting base, B-27

O

operating range

- extended performance compressor, 3
- medium temperature compressor, 4
- original IGV, 3

P

panel

- equipment, 11

physical data, 27

pipng considerations, 17

R

refrigerant type, 1

refrigeration circuits, D-40

S

shipping considerations, 18

specification

- accessories, 47
- cable, 11
- I/O wiring, 16
- supply voltage, 8
- temperature/pressure thermistor, 21
- water temperature thermistor, 19

suction filter kit, 2

suction service valve kit, 2

surge protection, 9

T

thermistor characteristics

- see specification

V

vibration, 18



Danfoss Turbocor Compressors Inc., 1850 Trans-Canada Highway, Dorval, Quebec H9P 2N4
Phone: 888-440-0523 Fax: 514-421-4277 www.turbocor.com