

# CHILLER SYSTEM INTERFACE

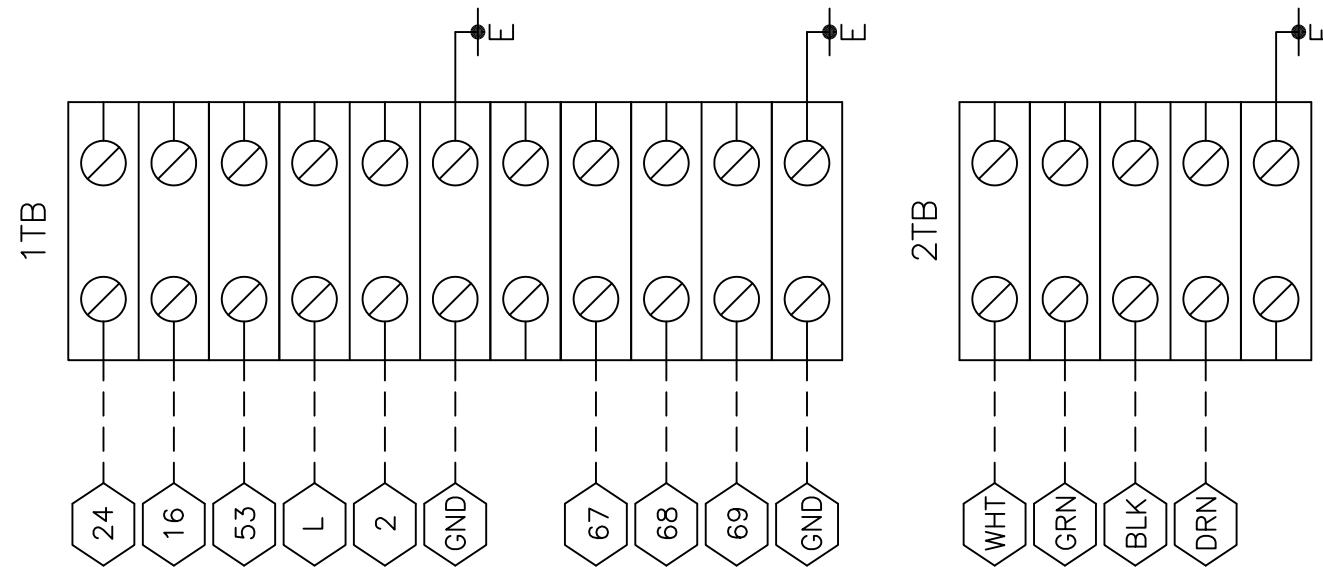

CUSTOMER TERMINAL BLOCK

|  |  |  |   |
|--|--|--|---|
| <b>YORK INTERNATIONAL CORPORATION</b><br>YORK, PA . 17405  |  |  |   |
| DIMENSIONS ARE IN INCHES<br>DO NOT SCALE<br>TOLERANCES PER ENG. STD. M-282<br>WELDING PER ENG. STD. M-30<br>REF. DWG.  |  | <b>CHILLER SYSTEM<br/>                 TERMINAL<br/>                 CONNECTIONS</b> |   |
| *ALL PROPRIETARY RIGHTS<br>IN THE SUBJECT MATTER<br>HEREOF ARE RESERVED,<br>AND NO PERMISSION IS<br>GRANTED TO REPRODUCE<br>THIS PRINT IN WHOLE<br>OR IN PART, OR DISCLOSE<br>ANY OF THE INFORMATION<br>UPON IT TO OTHERS<br>WITHOUT WRITTEN RELEASE<br>BY YORK INTERNATIONAL<br>CORPORATION*. |  | MATERIAL<br>TYPE _____ ENG. STD. _____<br>PART NO. _____<br>CUT SIZE _____           |   |
| DR. _____<br>APPR. _____<br>SCALE: _____   | NAME _____ DATE _____<br>SIZE <b>D</b> | CAGE NO _____<br>ORIG. NO. _____   | DRAWING NUMBER<br><b>1808K328</b><br>SHEET 14 of 15 |
| WT. = _____ LBS.   |  |  |   |

| REV. LEV. | DATE     | REVISION RECORD    | CHG. NO. | DR. | CK. | REV. LEV. | DATE | REVISION RECORD | CHG. NO. | DR. | CK. | REV. LEV. | DATE | REVISION RECORD | CHG. NO. | DR. | CK. |
|-----------|----------|--------------------|----------|-----|-----|-----------|------|-----------------|----------|-----|-----|-----------|------|-----------------|----------|-----|-----|
| 6         |          |                    |          |     |     | 13        |      |                 |          |     |     | 20        |      |                 |          |     |     |
| 5         |          |                    |          |     |     | 12        |      |                 |          |     |     | 19        |      |                 |          |     |     |
| 4         |          |                    |          |     |     | 11        |      |                 |          |     |     | 18        |      |                 |          |     |     |
| 3         |          |                    |          |     |     | 10        |      |                 |          |     |     | 17        |      |                 |          |     |     |
| 2         |          |                    |          |     |     | 9         |      |                 |          |     |     | 16        |      |                 |          |     |     |
| 1         | 02/05/08 | REMOVED 2TB JUMPER |          | OB  | AL  | 8         |      |                 |          |     |     | 15        |      |                 |          |     |     |
| 0         | 08/22/06 | FIRST ISSUE        |          | OB  | AL  | 7         |      |                 |          |     |     | 14        |      |                 |          |     |     |