

**TOSHIBA**  
Leading Innovation >>>

---

---

**T300MVi<sup>®</sup>/MTX<sup>®</sup>**

MEDIUM VOLTAGE 

**ADJUSTABLE SPEED MOTOR DRIVE**

---

---

# INSTRUCTION MANUAL

**TOSHIBA INTERNATIONAL CORPORATION**

Document Number: IF08CZ00  
November, 2015

TOSHIBA INTERNATIONAL CORPORATION  
13131 WEST LITTLE YORK  
HOUSTON, TEXAS 77041  
Tel: 1-713-466-0277  
1-800-231-1412

Printed in U.S.A.

## Important Notice

The instructions contained in this manual are not intended to cover all details or variations in equipment types, nor may it provide for every possible contingency concerning the installation, operation, or maintenance of this equipment. Should additional information be required contact your Toshiba representative.

The contents of this manual shall not become a part of or modify any prior or existing agreement, commitment, or relationship. The sales contract contains the entire obligation of Toshiba International Corporation. The warranty contained in the contract between the parties is the sole warranty of Toshiba International Corporation and any statements contained herein do not create new warranties or modify the existing warranty.

**Any electrical or mechanical modifications to this equipment without prior written consent of Toshiba International Corporation will void all warranties and may void the UL/CUL listing or other safety certifications. Unauthorized modifications may also result in a safety hazard or equipment damage.**

**Misuse of this equipment could result in injury and equipment damage. In no event will Toshiba Corporation be responsible or liable for either indirect or consequential damage or injury that may result from the misuse of this equipment.**

### TOSHIBA INTERNATIONAL CORPORATION

#### Adjustable Speed Drive

Please complete the Warranty Card supplied with the ASD and return it to Toshiba by prepaid mail. This will activate the 12 month warranty from the date of installation; but, shall not exceed 18 months from the date of purchase.

Complete the following information about the drive and retain it for your records.

Model Number: \_\_\_\_\_

Serial Number: \_\_\_\_\_

Project Number (if applicable): \_\_\_\_\_

Date of Installation: \_\_\_\_\_

Inspected By: \_\_\_\_\_

Name of Application: \_\_\_\_\_

## Manual's Purpose and Scope

This manual provides information on how to safely install, operate, and maintain your TIC power electronics product. This manual includes a section of general safety instructions that describes the warning labels and symbols that are used throughout the manual. Read the manual completely before installing, operating, or performing maintenance on this equipment.

This manual and the accompanying drawings should be considered a permanent part of the equipment and should be readily available for reference and review. Dimensions shown in the manual are in metric and/or the English equivalent.

Toshiba International Corporation reserves the right, without prior notice, to update information, make product changes, or to discontinue any product or service identified in this publication.

TOSHIBA is a registered trademark of the Toshiba Corporation. All other product or trade references appearing in this manual are registered trademarks of their respective owners.

**Toshiba International Corporation (TIC) shall not be liable for direct, indirect, special, or consequential damages resulting from the use of the information contained within this manual.**

This manual is copyrighted. No part of this manual may be photocopied or reproduced in any form without the prior written consent of Toshiba International Corporation.

© Copyright 2012 Toshiba International Corporation.

All rights reserved.

Printed in the U.S.A.

## Contacting Toshiba's Customer Support Center

Toshiba's Customer Support Center can be contacted to obtain help in resolving any **Adjustable Speed Drive** system problem that you may experience or to provide application information.

The center is open from 8 a.m. to 5 p.m. (CST), Monday through Friday. The Support Center's toll free number is US (800) 231-1412/Fax (713) 466-8773 — Canada (800) 527-1204.

You may also contact Toshiba by writing to:

Toshiba International Corporation  
13131 West Little York Road  
Houston, Texas 77041-9990  
Attn: ASD Product Manager.

For further information on Toshiba's products and services, please visit our website at [www.toshiba.com/ind](http://www.toshiba.com/ind).

## General Safety Instructions

**DO NOT** attempt to install, operate, maintain or dispose of this equipment until you have read and understood all of the product safety information and directions that are contained in this manual.

### Safety Alert Symbol

The **Safety Alert Symbol** indicates that a potential personal injury hazard exists. The symbol is comprised of an equilateral triangle enclosing an exclamation mark.



### Signal Words

Listed below are the signal words that are used throughout this manual followed by their descriptions and associated symbols. When the words **DANGER**, **WARNING** and **CAUTION** are used in this manual they will be followed by important safety information that must be adhered to.

The word **DANGER** preceded by the safety alert symbol indicates that an imminently hazardous situation exists that, if not avoided, will result in death or serious injury to personnel.



**DANGER**

The word **WARNING** preceded by the safety alert symbol indicates that a potentially hazardous situation exists that, if not avoided, could result in death or serious injury to personnel.



**WARNING**

The word **CAUTION** preceded by the safety alert symbol indicates that a potentially hazardous situation exists which, if not avoided, may result in minor or moderate injury.



**CAUTION**

The word **CAUTION** without the safety alert symbol indicates a potentially hazardous situation exists which, if not avoided, may result in equipment and property damage.

**CAUTION**

## Special Symbols

To identify special hazards, other symbols may appear in conjunction with the **DANGER**, **WARNING** and **CAUTION** signal words. These symbols indicate areas that require special and/or strict adherence to the procedures to prevent serious injury to personnel or death.

### Electrical Hazard Symbol

A symbol which indicates a hazard of injury from electrical shock or burn. It is comprised of an equilateral triangle enclosing a lightning bolt.



### Explosion Hazard Symbol

A symbol which indicates a hazard of injury from exploding parts. It is comprised of an equilateral triangle enclosing an explosion image.



### Arc Flash Hazard Symbol

A symbol which indicates a hazard of injury from arc flash. It is comprised of an equilateral triangle enclosing an arc flash image.



# Equipment Labels (Safety, Rating, Information)

**DO NOT** attempt to install, operate, perform maintenance, or dispose of this equipment until you have read and understood all of the product labels and user directions that are contained in this manual.

Shown below are examples of safety labels that may be found attached to the equipment. **DO NOT** remove or cover any of the labels. If the labels are damaged or if additional labels are required, contact your Toshiba representative for additional labels.

Labels attached to the equipment are there to provide useful information or to indicate an imminently hazardous situation that may result in serious injury, severe property and equipment damage, or death if the instructions are not followed.

**SAFETY labels that will be found on the equipment are shown below:**

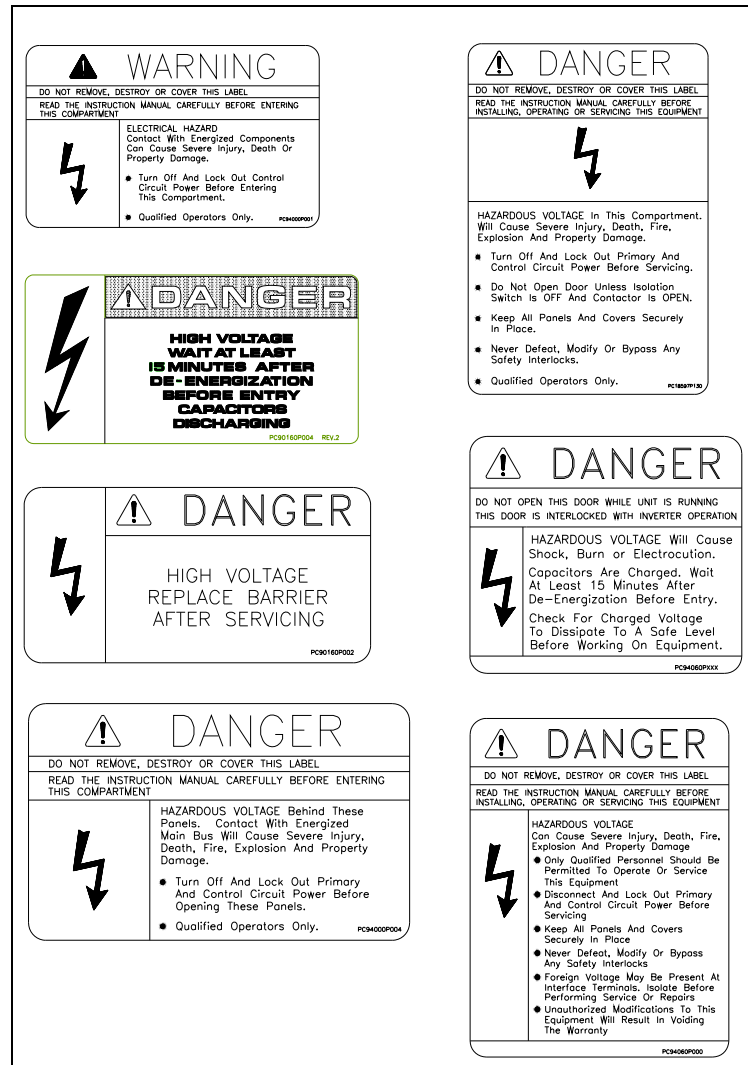

Additional SAFETY labels that will be found on the equipment or in the manual that has the CE mark applied are shown below:



Electrical hazard.



Electrical hazard with a minimum discharge time listed below.

xxx MIN



Electrical hazard with the system rated voltage listed below.

xxxxxxV



Do not remove covers or panels when energized.



Burn hazard from high surface temperatures.



Use and follow lock out tag out procedures



Read the manual.

RATING labels that will be found on the equipment are shown below:

**TOSHIBA INTERNATIONAL CORPORATION**  
**INPUT CONTROLLER FOR MV  
ADJUSTABLE SPEED MOTOR DRIVE**

Controller Type: \_\_\_\_\_ Mfg. Date: \_\_\_\_\_  
 JK SERIES NEMA CLASS E2  
U.S. PATENT NO. 5,481,075  
(2.4-6.9kV INPUT)  
 FUSED LOAD BREAK SWITCH/  
 CONTACTOR  
(7.2-13.8kV INPUT)

---

Controller Interrupting Capacity: 50,000A RMS Sym.  
 Contactor Interrupting Capacity: \_\_\_\_\_ A RMS Sym.  
 Impulse Test Voltage (BIL): \_\_\_\_\_ kV

**This Controller Equipped For:**  
 Utilization Voltage: \_\_\_\_\_ V Freq: \_\_\_\_\_ Hz  
 Max. Short Circuit Capacity: \_\_\_\_\_ MVA \_\_\_\_\_ Phase  
 Transformer Capacity: \_\_\_\_\_ kVA  
 Full Load A: \_\_\_\_\_ Overload: \_\_\_\_\_ %

**This Controller Configured As Follows:**  
 Power Fuse Type: \_\_\_\_\_  
 Power Fuse Current Rating: \_\_\_\_\_ Max. Voltage: \_\_\_\_\_ kV  
 CT Type: \_\_\_\_\_ Ratio: \_\_\_\_\_ Ampe  
 Control Voltage: \_\_\_\_\_ V Freq: \_\_\_\_\_ Hz  
 Contactor Type: \_\_\_\_\_  
 CPT-1 Size: \_\_\_\_\_ kVA Pri/Sec. Volts: \_\_\_\_\_  
 CPT-2 Size: \_\_\_\_\_ kVA Pri/Sec. Volts: \_\_\_\_\_

Schematic Diagram: \_\_\_\_\_  
 Optional Features: \_\_\_\_\_  
 \_\_\_\_\_  
 \_\_\_\_\_

---

Unit No. \_\_\_\_\_  
 Job No. \_\_\_\_\_

PC34060P16

Input Controller Rating Label

Note: If no input controller is supplied, this label will not be present. Refer to label on upstream equipment for rating data.

PROJ#/DWG#: \_\_\_\_\_  
 TYPE FORM: \_\_\_\_\_  
 CAPACITY: \_\_\_\_\_ kVA \_\_\_\_\_ kW \_\_\_\_\_ HP  
 INPUT: \_\_\_\_\_ kV \_\_\_\_\_ A \_\_\_\_\_ Hz \_\_\_\_\_  $\phi$   
 OUTPUT: \_\_\_\_\_ kV \_\_\_\_\_ A \_\_\_\_\_ Hz \_\_\_\_\_  $\phi$   
 CONTROL: \_\_\_\_\_ V \_\_\_\_\_ A \_\_\_\_\_ Hz \_\_\_\_\_  $\phi$   
 SERIAL #: \_\_\_\_\_ MFD. DATE: \_\_\_\_\_  
 Suitable For Use On a Circuit Capable of Delivering Not More  
 Than \_\_\_\_\_ RMS Sym. Amperes \_\_\_\_\_ kV Maximum.  
 IMPULSE TEST VOLTAGE (BIL): \_\_\_\_\_ kV

TOSHIBA INTERNATIONAL CORPORATION  
13131 W.LITTLE YORK RD., HOUSTON, TEXAS  
TELEPHONE (713)466-0277 PC34060P024

Adjustable Speed Drive Rating Label

TYPE-FORM : \_\_\_\_\_  
 RATING : \_\_\_\_\_  
 MFG. DATE : \_\_\_\_\_  
 SERIAL NO. : \_\_\_\_\_

**TOSHIBA INTERNATIONAL CORPORATION**

Inverter Power Module Rating Label

Note:

The above labels are shown blank. The labels affixed to the equipment will be filled in with rating data specific to the actual unit(s) furnished. Complete rating data is also provided on the rating sheet included in the supplementary drawing packet. Ensure that all rating data matches the power system and the driven load connected to the equipment.

**INFORMATION labels that will be found on the equipment are shown below:**

<i>TORQUE VALUES</i>		
HARDWARE SIZE	TORQUE (ft-lb)	TORQUE (kgf-cm)
1/4-20	4~6	55~83
5/16-18	10~15	138~207
3/8-16	20~30	276~415
1/2-13	40~50	553~691
USE ONLY 75°C COPPER CONDUCTORS		

Torque Label



Service Label



UL Label  
(for UL Listed drives)



CE Label  
(for drives designed  
for use in the  
European Union)

## Qualified Personnel

Installation, operation, and maintenance shall be performed by **Qualified Personnel Only**. A **Qualified Person** is one that has the skills and knowledge relating to the construction, installation, operation, and maintenance of the electrical equipment and has received safety training on the hazards involved. In the U.S., refer to the latest edition of NFPA 70E for additional safety requirements. Outside the U.S., follow all applicable national and local safety practices.

**Qualified Personnel** shall:

- Have read the entire operation manual.
- Be familiar with the construction and function of the ASD, the equipment being driven, and the hazards involved.
- Able to recognize and properly address hazards associated with the application of motor-driven equipment.
- Be trained and authorized to safely energize, de-energize, ground, lockout/tagout circuits and equipment, and clear faults in accordance with established safety practices.
- Be trained in the proper care and use of protective equipment such as safety shoes, rubber gloves, hard hats, safety glasses, face shields, flash clothing, etc., in accordance with established safety practices.
- Be trained in rendering first aid.

For further information on workplace safety in the U.S. visit [www.osha.gov](http://www.osha.gov). Outside the U.S., refer to your existing plant safety regulations.

## Equipment Inspection

- Upon receipt of the equipment inspect the packaging and equipment for shipping damage.
- Carefully unpack the equipment and check for parts that were damaged from shipping, missing parts, or concealed damage. If any discrepancies are discovered, it should be noted with the carrier prior to accepting the shipment, if possible. File a claim with the carrier if necessary and immediately notify your Toshiba representative.
- **DO NOT** install or energize equipment that has been damaged. Damaged equipment may fail during operation resulting in further equipment damage or personal injury.
- Check to see that the rated capacity and the model number specified on the nameplate conform to the order specifications.
- Modification of this equipment is dangerous and must not be performed except by factory trained representatives. When modifications are required contact your Toshiba representative.
- Inspections may be required before and after moving installed equipment.
- Keep the equipment in an upright position as indicated on the shipping carton.
- Contact your Toshiba representative for assistance if required.

## Handling and Storage

- Use proper lifting techniques when moving the ASD; including properly sizing up the load, getting assistance, and using a forklift if required.
- Store in a well-ventilated covered location and preferably in the original carton if the equipment will not be used upon receipt.
- Store in a cool, clean, and dry location. Avoid storage locations with extreme temperatures, rapid temperature changes, high humidity, moisture, dust, corrosive gases, or metal particles.
- Do not store the unit in places that are exposed to outside weather conditions (i.e., wind, rain, snow, etc.).
- Store in an upright position as indicated on the shipping carton.
- Include any other product-specific requirements.

## Disposal

Never dispose of electrical components via incineration. Contact your state environmental agency for details on disposal of electrical components and packaging in your area.

# Installation Precautions

## Location and Ambient Requirements

- Adequate personnel working space and adequate illumination must be provided for adjustment, inspection, and maintenance of the equipment. In the U.S., refer to NEC Article 110-34 for requirements. Outside the U.S., follow applicable local electrical code requirements.
- Avoid installation in areas where vibration, heat, humidity, dust, fibers, steel particles, explosive/corrosive mists or gases, or sources of electrical noise are present.
- Do not install the ASD where it may be exposed to flammable chemicals or gasses, water, solvents, or other fluids.
- The installation location shall not be exposed to direct sunlight .
- MTX drives are designed for outdoor use with exposure to rain and direct sunlight.
- Allow proper clearance spaces for installation. Do not obstruct the ventilation openings. Refer to the recommended minimum installation dimensions as shown on the enclosure outline drawings.
- The ambient operating temperature shall be between 0 and 40 °C (32 and 105 °F), unless stated otherwise.

## Mounting Requirements

- Only **Qualified Personnel** should install this equipment.
- Install the unit in a secure upright position in a well-ventilated area.
- A noncombustible insulating floor or mat should be provided in the area immediately surrounding the electrical system at the place where maintenance operations are to be performed.
- Equipment should be installed according to all applicable national, regional, and industry codes and standards. In the U.S., installation of the equipment should conform to NEC Article 110 Requirements For Electrical Installations and to OSHA requirements.
- In the U.S., installation practices should conform to the latest revision of NFPA 70E Electrical Safety Requirements for Employee Workplaces. Outside the U.S., applicable national and local installation safety practices should be followed. In the EU refer to section 6.5 of HD 637 and its sub clauses.

---

## Conductor Routing and Grounding

- Use separate metal conduits for routing the input power, output power, and control circuits.
- A separate ground cable should be run inside the conduit with the input power, output power, and control circuits.
- **DO NOT** connect control terminal strip return marked LG to earth ground.
- Always ground the unit to prevent electrical shock and to help reduce electrical noise.
- It is the responsibility of the person installing the ASD or the electrical maintenance personnel to provide proper grounding and branch circuit protection in accordance with all applicable national and local electrical codes (in the U.S. refer to the current version of NEC).



**WARNING**



**The Metal Of Conduit Is Not An Acceptable Ground.**

## Connections



**WARNING**



**Contact With Energized Wiring Will Cause Severe Injury Or Death.**

- Turn off, lockout, and tagout all power sources before proceeding to connect the power wiring to the equipment.
- After ensuring that all power sources are turned off and isolated in accordance with established lockout/tagout procedures, connect three-phase power source wiring of the correct voltage to the correct input terminals and connect the output terminals to a motor of the correct voltage and type for the application. In the U.S., refer to NEC Article 300 – Wiring Methods and Article 310 – Conductors For General Wiring and size the branch circuit conductors in accordance with NEC Table 310.16. Outside the U.S., follow your national and local electrical codes.
- If multiple conductors that are smaller than the recommended sizes are used in parallel for the input or output power, each branch of the parallel set shall have its own conduit and not share its conduit with other parallel sets (i.e., place U1, V1, and W1 in one conduit and U2, V2, and W2 in another) (refer to NEC Article 300.20 and Article 310.4 for U.S. requirements). National and local electrical codes should be referenced if three or more power conductors are run in the same conduit (in the U.S. refer to 2002 NEC Article 310 adjustment factors on page 70-142). Outside the U.S., consult your national and local electrical codes for additional requirements for running multiple conductors.
- Ensure that the 3 phase input power is **Not** connected to the output of the ASD. This will damage the ASD and may cause injury to personnel.
- Do not install the ASD if it is damaged or if it is missing any component(s).
- Turn the power on only after attaching and/or securing the front cover.
- Ensure the correct phase sequence and the desired direction of motor rotation in the **Bypass** mode (if applicable).

## Protection

- Ensure that primary protection exists for the input wiring to the equipment. This protection must be able to interrupt the available fault current from the power line. The equipment may or may not be equipped with an input disconnect (option).

When sizing and installing the upstream cabling and protection equipment:

- Consult the Manufacturer's Nameplate for Equipment Voltage and Current Requirements.
  - The equipment must be installed to meet the National Electrical Code rules of the country where installed as a branch circuit protector;
  - The equipment must bear a safety mark accepted by the country where installed;
  - The equipment must be installed by a qualified electrician.
- All cable entry openings must be sealed to reduce the risk of entry by vermin and to allow for maximum cooling efficiency.
  - Follow all warnings and precautions and do not exceed equipment ratings.
  - If using multiple motors provide separate overload protection for each motor and use V/f control.
  - External dynamic braking resistors, if supplied, must be thermally protected.
  - It is the responsibility of the person installing the ASD or the electrical maintenance personnel to setup the **Emergency Off** braking system of the ASD. The function of the **Emergency Off** braking function is to remove output power from the drive in the event of an emergency. A supplemental braking system may also be engaged in the event of an emergency.

**Note:** A supplemental emergency stopping system should be used with the ASD.

*Emergency stopping should not be a task of the ASD alone.*

## System Integration Precautions

The following precautions are provided as general guidelines for the setup of the ASD within the system.

- The Toshiba ASD is a general-purpose product. It is a system component only and the system design should take this into consideration. Please contact Toshiba for application-specific information and for training support.
- The Toshiba ASD is part of a larger system and the safe operation of the device will depend on observing certain precautions and performing proper system integration.
- A detailed system analysis and job safety analysis should be performed by the systems designer and/or systems integrator before the installation of the ASD component. Contact Toshiba for options availability and for application-specific system integration information if required.

## Personnel Protection

- Installation, operation, and maintenance shall be performed by **Qualified Personnel Only**.
- A thorough understanding of the ASD will be required before the installation, operation, or maintenance of the ASD.



- Rotating machinery and live conductors can be hazardous and shall not come into contact with humans. Personnel should be protected from all rotating machinery and electrical hazards at all times.
- Insulators, machine guards, and electrical safeguards may fail or be defeated by the purposeful or inadvertent actions of workers. Insulators, machine guards, and electrical safeguards are to be inspected (and tested where possible) at installation and periodically after installation for potential hazardous conditions.
- Do not allow personnel near rotating machinery. Warning signs to this effect shall be posted at or near the machinery.
- Do not allow personnel near electrical conductors. Human contact with electrical conductors can be fatal. Warning signs to this effect shall be posted at or near the hazard.
- Personal protection equipment shall be provided and used to protect employees from any hazards inherent to system operation.

## System Setup Requirements

- When using the ASD as an integral part of a larger system, it is the responsibility of the ASD installer or maintenance personnel to ensure that there is a fail-safe in place, i.e., an arrangement designed to switch the system to a safe condition if there is a fault or failure.
- System safety features should be employed and designed into the integrated system in a manner such that system operation, even in the event of system failure, will not cause harm or result in personnel injury or system damage (i.e., E-Off, Auto-Restart settings, System Interlocks, etc.).
- The programming setup and system configuration of the ASD may allow it to start the motor unexpectedly. A familiarity with the Auto-restart settings is a requirement to use this product.
- Improperly designed or improperly installed system interlocks may render the motor unable to start or stop on command.
- The failure of external or ancillary components may cause intermittent system operation, i.e.; the system may start the motor without warning.
- There may be thermal or physical properties, or ancillary devices integrated into the overall system that may allow for the ASD to start the motor without warning. Signs at the equipment installation must be posted to this effect.
- If a secondary magnetic contactor (MC) is used between the ASD and the load, it should be interlocked to halt the ASD before the secondary contact opens. If the output contactor is used for bypass operation, it must be interlocked such that commercial power is never applied to the ASD output terminals (U, V, and W).
- Power factor improvement capacitors or surge absorbers must not be installed on the output of the ASD.
- Use of the built-in system protective features is highly recommended (i.e., E-Off, Overload Protection, etc.).
- The operating controls and system status indicators should be clearly readable and positioned where the operator can see them without obstruction.
- Additional warnings and notifications shall be posted at the equipment installation location as deemed required by **Qualified Personnel**.

## Operational and Maintenance Precautions



**WARNING**



- Turn off, lockout, and tagout the main power, the control power, and instrumentation connections before inspecting or servicing the drive, or opening the door of the enclosure.
- Turn off, lockout, and tagout the main power, the control power, and instrumentation connections before proceeding to disconnect or connect the power wiring to the equipment.
- The capacitors of the ASD maintain a residual charge for a period of time after turning the ASD off. The required time for each ASD typeform is indicated with a cabinet label and a **Charge LED**. Wait for at least the minimum time indicated on the label and ensure that the **Charge LED** has gone out before opening the door of the ASD once the ASD power has been turned off.
- **Do Not** attempt to disassemble, modify, or repair the ASD. Call your Toshiba sales representative for repair information.
- Do not place any objects inside of the ASD.
- Turn the power on only after attaching (or closing) the front cover and **Do Not** remove the front cover of the ASD when the power is on.
- If the ASD should emit smoke or an unusual odor or sound, turn the power off immediately.
- The heat sinks, magnetics, and other components may become extremely hot to the touch. Allow the unit to cool before coming in contact with these items.
- Remove power from the ASD during extended periods of non-use.
- The system should be inspected periodically for damaged or improperly functioning parts, cleanliness, and to ensure that the connectors are tightened securely.
- Ensure that the **Run** functions (**F**, **R**, **Preset Speed**, etc.) of the ASD are off before performing a **Reset**. The post-reset settings may allow the ASD to start unexpectedly.
- In the event of a power failure, the motor may restart after power is restored.
- **Retry** or **Reset** settings may allow the motor to start unexpectedly. Warnings to this effect should be clearly posted near the ASD and motor.

**DO NOT** install, operate, perform maintenance, or dispose of this equipment until you have read and understood all of the product warnings and user directions. Failure to do so may result in equipment damage, operator injury, or loss of life.

This page intentionally left blank.

---

## CONTENTS

INTRODUCTION.....	1
INITIAL COMMISSIONING .....	2
Confirmation of Wiring .....	2
Start-Up and Test .....	2
Cautions on Changing Setting Parameters .....	3
INSPECTIONS AND MAINTENANCE .....	4
Daily Inspections .....	4
Regular Inspections.....	4
Main Components .....	5
Cautions on Handling Printed Wiring Boards .....	5
Parts to be Regularly Renewed.....	6
Recommended Spare Parts .....	7
Preparations for Inspection and Maintenance of Equipment (Powering-Off) .....	8
Recovery after Inspection and Maintenance of Equipment (Powering-On) .....	9
OVERVIEW.....	10
Display/Keypad (MVi-EOi).....	10
<i>MVi-EOI Diagram</i> .....	10
How to Handle Faults .....	12
Description of Terminology.....	12
General Specifications (Structure).....	13
Altitude and Temperature De-rating .....	14
Motor Cable Length .....	14
General Specifications (Electrical).....	15
General Specifications (Control).....	16
Rating Specifications .....	18
Protective Functions .....	21
General Cubicle Structure .....	23
Cubicle Structure and Dimensions .....	23
Dimensions and Weights of Equipment.....	24
INTERFACE.....	27
Power Supply Interface and Ground .....	27
Grounding .....	27
Motor Interface .....	28
Speed Sensor Interface (Option).....	28
Resolver .....	28
PG (Pulse Generator).....	28
Pulse Signal Output.....	29
Digital Input .....	29
Digital Output.....	32
Analog Input .....	32
Analog Output .....	33
General-purpose Analog Output.....	33
Additional Analog Outputs .....	34
Motor Mounted Fan Circuit .....	34
CIRCUIT OPERATION .....	35
Main Circuit Configuration .....	35

---

Control.....	39
Vector Control Block Diagram .....	39
V/f Control Block Diagram .....	39
Speed Reference .....	40
Vector Control Speed Control.....	41
Vector Control Simulator Follower Control (SFC, optional control used with a speed sensor) .....	42
Vector Control Torque Reference and Current Reference .....	42
Vector Control IQ Limit (Torque current limit) .....	43
Vector Control D-Q Axis Current Control.....	44
V/f Control .....	45
Control Circuit for SM (Synchronous Motor) control .....	46
SM Control Block Diagram .....	47
Speed Feedback (Option) .....	48
Resolver .....	48
PG .....	48
OPERATION .....	49
Pre-Operation Check Points.....	50
Powering-On .....	50
Operation.....	50
Normal Operation .....	50
Powering-Off .....	50
DATA CONTROL .....	51
Setting Data.....	51
FAULT AND RECOVERY .....	51
Cautions when Handling Fault.....	51
Repair.....	52
Cautions on Repair.....	52
DRIVE INSTALLATION DRAWINGS .....	53
Frame 0 4160V module lifting and installation.....	53
Frame 1 4160V drive lifting and assembly.....	53
Frame 1 drive lifting and assembly (cont'd).....	54
Frame 1 2400V module lifting and installation.....	55
Frame 1 4160V module lifting and installation .....	55
Frame 2 drive lifting and assembly .....	56
Frame 2 drive main cable installation .....	57
Frame 2 module lifting.....	58
Frame 2 4160V module installation .....	59
Frame 3 drive lifting and assembly .....	60
Frame 3 drive main cable installation .....	61
Frame 3 2400V module installation .....	63
Frame 3 4160V module installation .....	64
Frame 4 drive lifting and assembly.....	65
Frame 4 drive main cable installation .....	66
Frame 4 module lifting.....	67
Frame 4 2400V module installation .....	68
Frame 4 4160V module installation .....	69

---

---

Frame G4P drive main cable installation .....	71
Frame G4P module lifting and installation .....	72
Frame G4P module lifting and installation continued .....	73
Frame H4P drive lifting and assembly .....	74
Frame H4P drive main cable installation .....	75
Frame H4P module lifting and installation .....	76
Frame H4P module lifting and installation continued .....	77
Frame A2 module lifting and installation .....	78
Frame A2 drive lifting and assembly .....	79
Frame B2 2400V module lifting and installation Type 1 .....	80
Frame B2 module lifting and installation Type 2 .....	81
Frame B2 drive lifting and assembly .....	82
Frame D2 module lifting and assembly .....	83
Frame D2 drive lifting and assembly .....	84
Frame D2 drive main terminal locations .....	85
Frame A4 $\mu$ module lifting and installation .....	86
Frame A4 $\mu$ drive lifting and assembly .....	87
Frame A4 module lifting and installation .....	88
Frame A4 drive lifting and assembly .....	89
Frame B4 module lifting and installation .....	90
Frame B4 drive lifting and assembly .....	91
Frame B6S module lifting and installation .....	92
Frame B6S drive lifting and assembly .....	93
Frame B6S drive main terminal locations .....	94
Frame C6S module lifting and installation .....	95
Frame C6S drive lifting and assembly .....	96
Frame C6S drive main terminal locations .....	97
Frame D6S module lifting and installation .....	98
Frame D6S drive lifting and assembly .....	99
Frame D6S drive main terminal locations .....	100
Frame F6S & F6S+ module lifting and installation .....	101
Frame F6S drive lifting and assembly .....	102
Frame F6S+ drive lifting and assembly .....	103
Frame F6S & F6S+ drive main terminal locations .....	104
Frame MTX15 drive lifting and assembly .....	105
Frame MTX30 drive lifting and assembly .....	106

## INTRODUCTION

Thank you for purchasing the T300MVi/MTX Medium Voltage ASD. This adjustable frequency, solid-state AC drive features a 3 $\phi$  input isolation transformer with a 24/36-pulse converter design, a 32-bit CPU, and a three-unit power module inverter section providing a 7 level output for 6600V drives, a 5 level output for 4160/3300V drives and 3 level output for 2400V drives. These drives also feature as standard, an 8 key Control Panel with a LCD screen and 2 discrete LED lamps to indicate Ready, Run, Local, Remote and Alarm/Fault.

On most power systems, this drive will meet IEEE-519-1992 harmonic regulation guidelines without installing additional harmonic filters. The input power factor is typically 0.95. The multi-level output produces a more sinusoidal voltage and reduces stress on the motor winding insulation. This drive uses high capacity 3300V IGBTs to improve reliability, reduce switching losses, and improve control performance. The PP7 control processor and 6-layer control board achieves high integration and reliability.

**INITIAL COMMISSIONING**



**CAUTION**

The drive should be commissioned by qualified personnel only. Below are some general steps required for commissioning.

**Confirmation of Wiring**



**CAUTION**

Make the following final checks before applying power to the unit:

- 1) Confirm that source power is connected to terminals L1, L2, L3 (R, S, T). **Connection of incoming source power to any other terminals will damage the drive. Other control voltages may be required. Consult your custom equipment diagrams shipped with the drive for any other requirements.**
- 2) Verify that the power modules are properly installed and that there was no damage during shipping or handling.
- 3) Verify that there are no loose connections or wires and that all of the required shipping split connections have been made.
- 4) Verify all external control circuit wiring is complete and properly connected.
- 5) The 3-phase source power should be within the correct voltage and frequency tolerances.
- 6) The motor leads must be connected to terminals T1, T2, T3 (U, V, W).
- 7) Make sure there are no short circuits or inadvertent grounds and tighten any loose connector terminal screws.

**Start-Up and Test**



**CAUTION**

**Prior to releasing the drive system for regular operation after installation, the system must be adjusted and tested by qualified personnel.** This assures correct operation of the equipment for reasons of reliable and safe performance. It is important to make arrangements for such a check and that time is allowed for it.

### Cautions on Changing Setting Parameters



### CAUTION

The setting data of the T300MVi/MTX MV is saved in an EEPROM, non-volatile memory. When the micro controller initializes at power-up, it reads the EEPROM data and copies it to the RAM (Random Access Memory). From then on, the micro controller controls the drive using the values in the RAM.

When the setting parameters are changed, by the display-keypad or personal computer ("support tool"), only the execution parameters in RAM are changed. If they need to be stored, they must be manually written to the EEPROM. Without this operation, the next initialization or power up will cause them to be replaced by the old data.

When a write to the EEPROM is performed, write processing may take 30 seconds. Turning off the control power supply during write processing will make both the RAM and EEPROM data abnormal. When the power is turned on again, this abnormal data will result in an error ("CHECK ERROR") preventing the drive from running. If such an error occurs, the settings must be reloaded from a saved file. If no setting file exists, the drive must be re-commissioned.

**Do not turn off the control power supply under any circumstances while writing data to the EEPROM.**

## INSPECTIONS AND MAINTENANCE



**CAUTION**



**DANGER**



Maintenance and inspection is a particularly effective means to help prevent failures and reduce down time. Creating equipment specific inspection and maintenance check sheets can help to perform maintenance and inspection effectively. Detailed inspections and regular maintenance should be carried out in short cycles initially until a schedule reflecting the site-specific conditions can be determined.

For items that are too high to reach, use a step ladder to gain access. Do not attempt to climb on the equipment.

### Daily Inspections

Daily inspections consist mainly of **visual** inspections on the following items. These observations should be made with all of the cubicle doors closed and safety covers installed. Any abnormalities discovered should immediately be repaired.

- 1) Check the temperature, the humidity, the presence of corrosive or explosive gases, and the presence of dust in the area.
- 2) Check for any abnormal sound or vibration of the reactor, transformer, or cooling fans.
- 3) Check for abnormal odors such as the smell of burning insulating materials.

### Regular Inspections



**CAUTION**



**DANGER**



Carry out regular inspections **with power off, locked out, and with confirmation that the bus voltage is completely discharged**. Use power **lockout/tagout procedure** on the disconnecting means in accordance with applicable local electrical codes (in the U.S., see 2002 NEC Article 430-101) before performing any drive maintenance.

The first thing to do in maintenance and inspection is cleaning. Cleaning should be carried out according to the conditions of the equipment. Before starting cleaning, turn off the power supply and check that the main circuit voltage is reduced to 0. Clean dust with a vacuum, dry compressed air, and clean dry cloths. Note that excessive air pressure when blowing out equipment may damage parts and wiring. **Do not use solvents to clean the drive**. Substances stuck to the circuits, which cannot be removed by blowing, should be wiped away using a cloth. As a basic rule, cleaning should start from the upper parts and end at the lower parts. Cleaning of the lower parts last will allow proper removal of substances that could drop from the upper parts.

**INSPECTIONS AND MAINTENANCE**  
(cont'd)



**CAUTION**



**Main Components**

- 1) Cooling fan - Check to see if there is any abnormality with airflow, increased fan noise, etc.
  
- 2) Air filter - Visually check if the air filter is clogged. Gently tap it outside the room to remove loose dust. To remove caked on dirt use water and a gentle detergent, rinse it with clean water and dry it. Otherwise replace it with a new one. **Cleaning with solvents is not recommended.**
  
- 3) Main circuit parts and entire cubicle - Check to see if dust is stuck to the cubicle interior or if there is any discoloration, heat generation, abnormal sound, leakage, odor or damage with the reactor, transformer, contactors, cables and connections, fuses, capacitors, lightning arrestors, and resistors. Check to see that no wires or mounted parts are broken, disconnected, loose or damaged. High voltage standoffs, insulators, and cable can be cleaned with isopropyl alcohol.
  
- 4) Printed Wiring Boards - The boards, which are made up of ICs and electronic components, must be protected from dust, corrosive gases and extreme temperatures. Pay attention to the installation environment of the equipment. Regular inspections, the proper cleaning, and maintenance in an optimal environment is essential for circuit boards. Since most of the components and parts are small and vulnerable to external forces, when cleaning them, use a brush to carefully wipe off dust. Inspect the boards for signs of component damage, heating, and corrosion.

**Cautions on Handling Printed Wiring Boards**

- a) All maintenance work on the board should be carried out at least 15 minutes after all power supplies are turned off to allow the capacitors on the boards to discharge.
  
- b) When removing the board, disconnect all the connectors and wires and remove the mounting screws from the upper part of the board first. At this time, be careful not to drop the boards or screws. When setting the board down, place it on a static free surface. Be careful not to damage any components.
  
- c) When attaching the board, do so in the order opposite to the removing procedure. Be sure that all of the connectors and wires are connected correctly.
  
- d) New boards are shipped in an anti-static bag. Use this bag to store them.

**Note that the anti-static coating is only on the inner side of the bag.**

- 5) Check the protection functions for proper operation (Door switches, OH, E-stop...)
  
- 6) Check the insulation resistance of the medium voltage circuits.

**INSPECTIONS AND MAINTENANCE**  
**(cont'd)**



**CAUTION**

**Parts to be Regularly Renewed**

To use the T300MVi/MTX for a maximum period of time, it is necessary to regularly renew (replace) components whose characteristics have deteriorated. The table below shows the parts used for the inverter equipment whose regular renewal is recommended for critical applications and their recommended renewal period. We always recommend that spares be on hand to reduce down time.

**Parts to be Regularly Renewed**

Product name	Recommended renewal period	Remarks
Cooling fan	7 years	Sooner if dust or dirt damages bearings
Air filter	6 months	Can also be cleaned.
Aluminum Electrolytic Capacitors On Circuit Boards	7 years	Contact Toshiba for replacement of these devices
Oil-filled capacitor Main circuit	20 years	
Control power supply	7 years	
Fuse	Main circuit	7 years
	Control circuit	7 years

## Recommended Spare Parts

Spare parts are an important part of downtime reduction. When parts in the drive have failed, on-hand spare parts are necessary to shorten the mean time to repair (MTTR). Since replacement of discrete components is time consuming, it is recommended that entire assemblies be replaced. Recommended spare parts common to all drives are shown in the following tables. The recommended spare rate and minimum amount can serve as references for the minimum number of spare parts relative to the total number of drives on site. It is recommended that the quantity be determined in accordance with the number drives on site. Many other parts are job specific. It is up to the end user to determine what other parts may be needed.

### Recommended Common Spare Parts \*\*

Product name	Model/Rating		Number of parts per drive	Recommended spare parts	
			4160V/2300V	Spare rate	Recommended Min Q'ty
CTR	Control board	ARND-3110(*)	1 each	10%	1
GSD	Gate signal distribution board	ARND-3126B	1 each	10%	1
OLB	Optical gate signal board	ARND-8205(*)	3 each	10%	1
XIO	External input/output board	ARND-8120(*)	1 each	10%	1
VDET	Voltage detection board	ARND-3127(*)	3 each	10%	1
IPAD	Keypad interface board	PC61910PP114A	1 each	10%	1
DISP	Display/keypad	PC61910P116	1 each	10%	1
PS1	Control power supply	FYX900/63T-BGEE	1 each	10%	1
GDI	Earth fault detection	ARND-8126A	1 each	10%	1
TEX	Twin expansion board	PC61910P123(*)	1/0	10%	1
Control Fuses	*	*	2 each	10%	2
Main Fuses	*	*	3 each	10%	3
Pt fuses	*	*	4 each	10%	4
Rectifier fuses	*	*	36/12	10%	6/3
Power modules***	*	*	3	10%	1
Cooling Fans	*	*	*	10%	1

\* This data is job/inverter specific. Check the drawings for the specific inverter for this information.

\*\* This is a general list of spares. Check the specific job drawings for other components that may need to be spared.

\*\*\* It is recommended that failed power modules be replaced as a unit and that the failed modules be returned to Toshiba for repair and testing. (T300MVi). For Twin drives, there are 6 modules. For 6600V drives there 3x2400V modules and 3x4160V modules. The MTX series requires field repair of the module by factory trained personnel.

**Preparations for Inspection and Maintenance of Equipment (Powering-Off)**

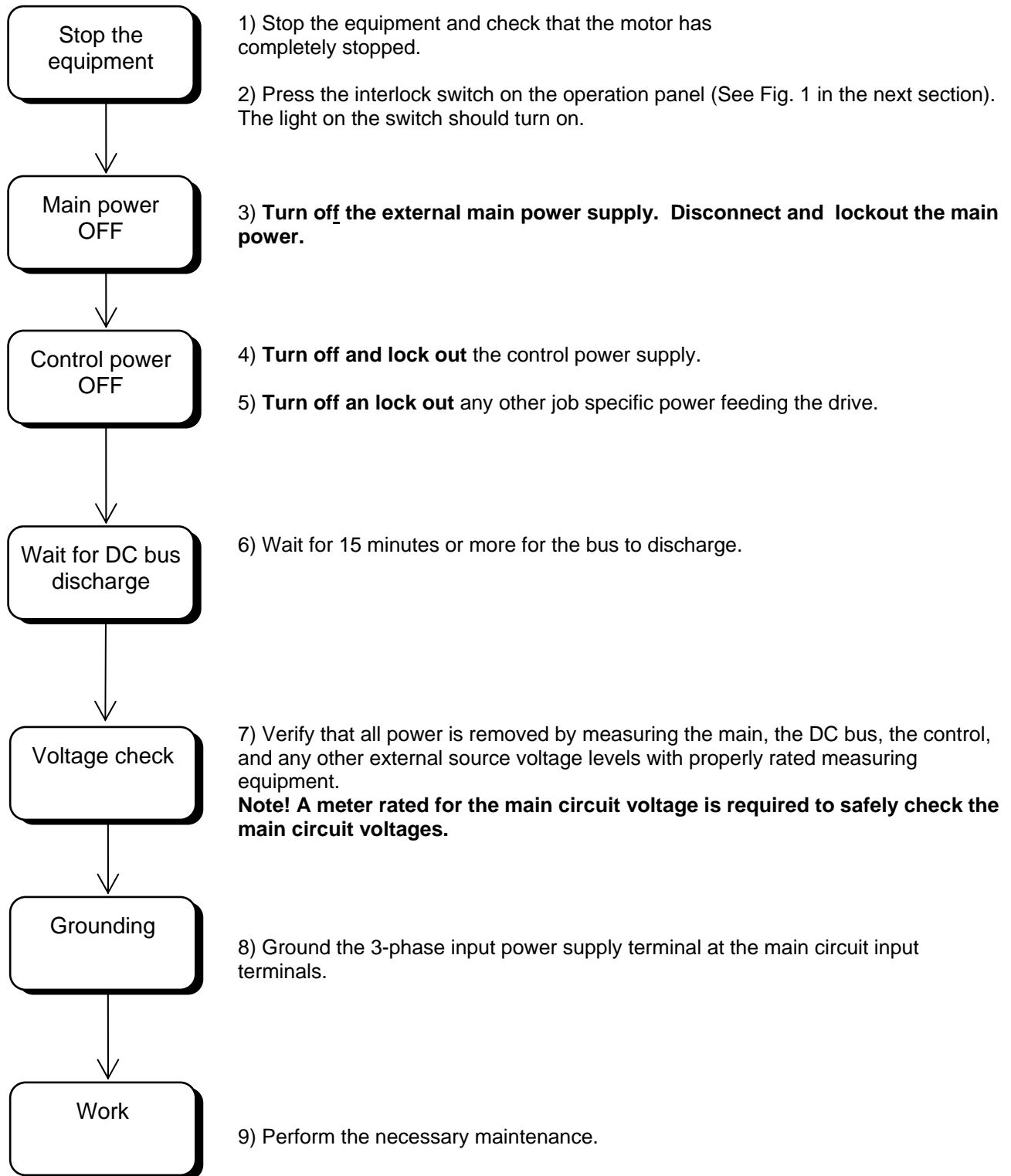

### Recovery after Inspection and Maintenance of Equipment (Powering-On)

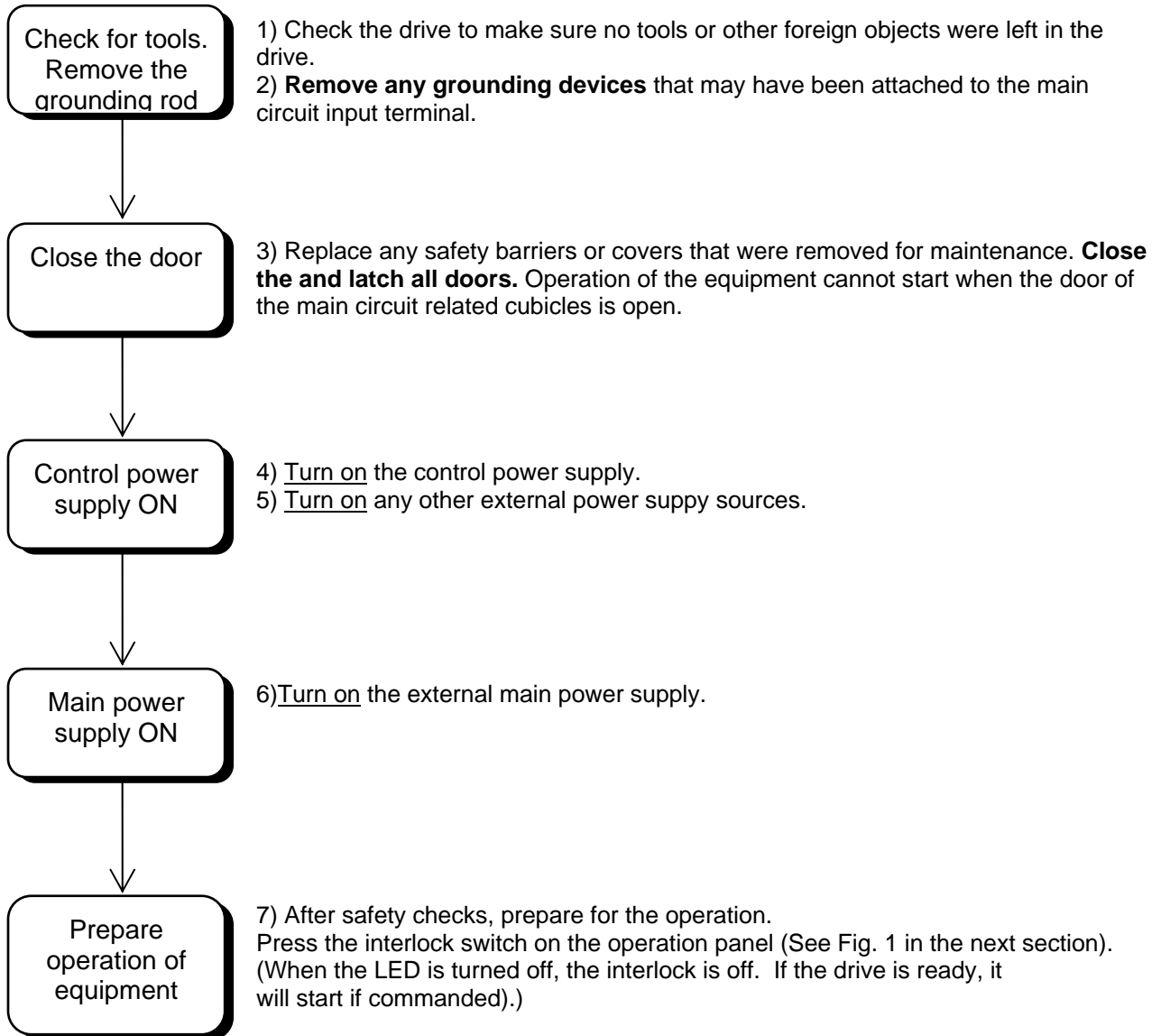

**OVERVIEW**

**Display/Keypad (MVi-EOi)**

The following figure shows the display/keypad of the equipment. Refer to the keypad operation manual for more details on its use.

*MVi-EOI Diagram*

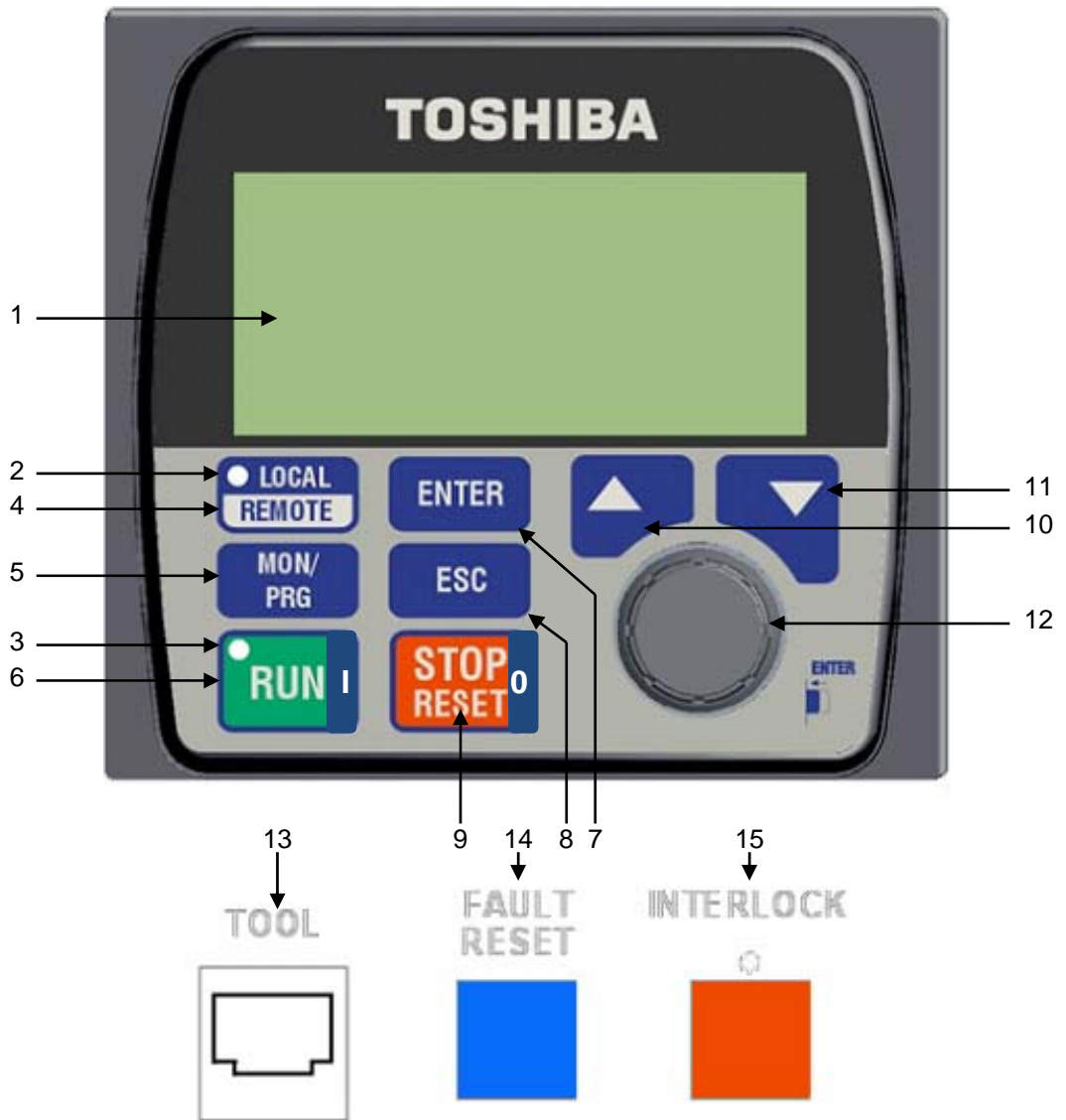

**Figure 1.**

1. Graphical LCD – Displays user information in text and numerical form.
2. Local/Remote LED – This green LED is illuminated when in local mode, and extinguished while in remote mode.
3. Status LED:
  - Not ready and not running – Both Red and Green off.
  - Ready and not running – Green LED only
  - Ready and running – Red LED only.
  - Fault – Fast blinking Red LED. (2.0 Hz).
  - Alarm – Slow blinking red if running or, green if not running. (0.67 Hz).
  - Test mode – Alternating red and green when in ready or running condition. (2.0 Hz).
4. LOCAL/REMOTE Key – Toggles between Local and Remote mode while the drive is not running. Press and hold the key for two seconds to toggle modes.
5. MON/PRG Key – This key will cycle through the tabs (see figure 2).
6. RUN Key – Initiates a start command when the ASD is in local mode, and the MVi-EOI is in the Main Tab.
7. ENTER Key – Selects a menu item to be changed or accepts and writes the changed data of a selected field. While in the Main Tab, press and hold this key for two seconds to toggle the direction of the motor.
8. ESCAPE Key – This multi-function Escape key allows the user to cancel changes made to a programming field if pressed while the field is selected (highlighted), returns the user to the previous level of the menu tree, and cycles through the display tabs.
9. STOP key – This initiates a stop request when operating in local mode, and is functional in all screens. When double pressed within 1.5 seconds, it initiates a (gate block) coast to stop. This function always works. The drive must be reset after a double-press stop.
10. UP key – Scrolls up a menu listing and increments a selected field's parameter data.
11. DOWN key – Scrolls down a menu listing and decrements a selected field's parameter data.
12. Encoder – This multi-function device scrolls up and down a menu listing, increments/decrements the data in a selected programming parameter field, and functions as the Enter key when pressed.
13. Commissioning Tool Port – Ethernet port used for communication to the commissioning and support tool (Wi-Tool).
14. RESET Pushbutton – This pushbutton is used to clear inverter faults and alarms displayed on the LCD.
15. INTERLOCK Pushbutton – This pushbutton is used to disable the inverter via a hard-wired circuit. The pushbutton is illuminated while the inverter is interlocked, and extinguished for normal operation. Operating the INTERLOCK pushbutton will result in an inverter gate block and free-run deceleration of the load.

## How to Handle Faults

In the event of a fault, the following measures should be taken:

- (1) Record the fault message shown on the display on the operation panel.
- (2) Collect the trace back data, if the commissioning software package was purchased.
- (3) See the Fault and Recovery section.

## Description of Terminology

This section describes the special terms used in this manual.

### Description of Terminology

Term	Meaning
Power module	A single-phase DC-fed inverter module using IGBTs.
IGD board	IGBT Gate Driver Board. Converts gate signals sent in optical signal form to electric signals.
OLB board	Optical Link Board. Converts gate signals from electric to optical signals for isolation.
VDET board	Voltage Detection Board. Board that measures analog voltage signals and converts them to optical signals.
GSD board	Gate Signal Distributor. Board that distributes gate signals to each output phase.
CTR board	Inverter main control board
TEX board	Twin Expansion Board. Distributes the gate signals to the power modules for twin drives.
EEPROM	Electrical Erasable Programmable Read Only Memory
IGBT	Insulated Gate Bipolar Transistor
LCD	Liquid Crystal Display
LED	Light Emitting Diode
MCCB	Molded Case Circuit Breaker
PP7	Power electronics Processor for Various Inverter control Integration (VII=7). Toshiba dedicated power electronics control 32-bit micro-controller.
PSM	Switching power supply that providing $\pm 15$ VDC and +5 VDC for boards.
RAM	Random Access Memory
Initialize	Act of initialization. When the control power switch is turned from OFF to ON the inverter equipment initializes data and circuits.
Interface	Means by which this equipment transfers signals to/from external devices.
Inverter	Inverse converter that converts DC power to AC power. (DC $\rightarrow$ AC conversion)
Overload	Operation at a current output that exceeds the continuous rating of the equipment.
Display-keypad	Operational panel installed on the cubicle surface that is used for data display and basic operations.
Load	Refers to a motor that receives power from this equipment.

**General Specifications (Structure)**

The general specifications (structure) of the equipment are shown in the following table.

General Specifications (Structure)

Item		Standard specification	Additional optional specification	Remarks	
Applicable standard		UL, NEMA			
Ambient conditions	Temperature	0 to 40°C for T300MVi -20 to 50C for MTX series	50C operation for T300MVi with a derate.		
	Humidity	Max 95%, no condensation		At no time should the drive be subjected to conditions that would allow condensation to form on the components.	
	Altitude	1000 m Max. above sea level	Higher altitudes with a derate and special magnetics.		
	Installation location	Indoors Outdoors for MTX series			
	Vibration	10 to 60 Hz, 0.5 G or less			
	Corrosive factors	Hydrogen Sulfide (H <sub>2</sub> S) ≤ 0.001 PPM			This is a list of corrosive agents know to attack the drive components. Other agents may also have adverse effects on the drive.
		Sulfur Dioxide (SO <sub>2</sub> ) ≤ 0.05 PPM			
Chlorine gas (Cl <sub>2</sub> ) ≤ 0.1 PPM					
Ammonia gas (NH <sub>3</sub> ) ≤ 0.1 PPM					
Nitrogen Dioxide (NO <sub>2</sub> ) ≤ 0.02 PPM					
Nitrogen Oxide (NO <sub>x</sub> ) ≤ 0.02 PPM					
Ozone (O <sub>3</sub> ) ≤ 0.002 PPM					
Hydrochloric acid mist (HCl <sub>1</sub> ) ≤ 0.1 mg/m <sup>3</sup>					
Paint color	Cubicle surface	ANSI 61 Gray (T300MVi) White (MTX)	Consult factory for optional colors		
Cubicle structure		Front maintenance (T300MVi) MTX requires back access			
Cubicle protective structure		NEMA 1, Forced ventilated (T300MVi) N3R (MTX series) With channel base			
Air filter		Front mounted (T300MVi)			

**Altitude and Temperature De-rating**

Altitude Derate Chart \*\*

Altitude	% Amp Output Derate
3,300'	0.0%
4,000'	2.0%
4,500'	3.3%
5,000'	4.7%
6,000'	7.5%
7,000'	10.2%
8,000'	12.9%
9,000'	15.7%
10,000'	18.4%

\*\* Applications above 5000 feet, require special consideration regarding both the magnetics and the available voltages. Consult Toshiba Engineering.

Temperature Derate Chart (T300MVi only)

Ambient Temperature	% Amp Output Derate
40 °C	0.0%
45 °C	7.5%
50 °C	15.0%

**Motor Cable Length**

Below are cable length guidelines for use with most standard industrial motors.

**Suggested Maximum Output Cable Distances**

AC Motor Voltage	Drive Output Voltage	Max lead length without filter
2300	2400V	0-1000 ft
2300/4000	2400V	0-1000 ft
4000V or 2300/4000	4160V	0-1000 ft
6600V	6600V	0-1000 ft



**CAUTION**

(1) Older motors, or motors with marginal insulation systems, may require filters to help reduce the stress on the insulation system. Consult Toshiba application engineering.

(2) Exceeding the peak voltage and allowable rise time of the motor insulation system will reduce motor life expectancy. To insure good insulation life, consult with the motor supplier to determine motor insulation ratings and allowable maximum output lead distance. Long lead lengths between the motor and drive may require that filters be added to the drive output.

**General Specifications (Electrical)**

The general (electrical) specifications of the equipment are shown in the following table.

General (Electrical) Specifications

Item		Standard specification	Standard Optional Specification	Additional Optional Specification	Remarks	
Frame Sizes		2400V	0, A2, 1, B2, 3, D2, 4		See ratings table for specific kVA ratings available	
		4160V	0, A4 $\mu$ , A4,1, 2, 3, 4, G4P, H4P, MTX15, MTX30			
		6600V	B6S,C6S,D6S,F6S ,F6S+			
Motor driven by this equipment		Squirrel-cage induction motor	Synchronous motor			
Main power supply	Input supply voltage and range of fluctuation	Rated Voltage $\pm 10\%$ Rated Frequency $\pm 5\%$				
	Output voltage	0 ~ Rated Voltage				
Control power supply	Supply voltage frequency	Internally supplied 480 V, 60 Hz T300MVi and MTX30. Internally supplied 240 V, 60 Hz MTX15.	Internally supplied 480 V, 50 Hz T300MVi and MTX30. Internally supplied 240 V, 50 Hz MTX15.		MTX series requires externally supplied space heater power.	
Main circuit	PWM frequency	1024Hz 2400V 2048Hz 4160V 1024Hz 6600V				
	Regeneration system	Not available				
Others	Overload capacity	100% - continuous 110-115% - 60 sec (Depends upon frame size and drive rating)		125%,150%, 175%,200% 225%,250%	The higher OL ratings require a reduction in continuous capacity	
	Ground protection	Yes				
	Receptacle	No		Yes		
	Motor cooling fan control	No		Yes		
	Cabinet space heater	No		Yes		
	Cabinet internal light	No				
	Typical operating sound levels measured at a distance of 1m x 1.5m high	LpAm (Operator)	78 dBA			
		LpAm (Bystander)	78 dBA			
LpC (Operator)		79 dBC				

**General Specifications (Control)**

The general (control) specifications are shown in the following table.

General Control Specifications

Item		Standard specification	Additional optional specification	Remarks
Maximum output frequency		75 Hz	90Hz all drives 120 Hz for 4160V drives only	90 Hz max with a sinewave filter
Speed sensor (PG pulse output)		No	Yes	
Basic control performance	Basic control system	Induction Motor Volts/Hertz	Induction Motor Sensor Type Vector	Sensor type vector control uses a1x resolver or a PG. The maximum PG freq. is 10kHz.
			Induction Motor Sensorless Vector	
			Synchronous Motor	
	Operation control range	3%-100%	1%-100%	Limited by motor heating
	Field weakening control	1:1.5	1:5	Vector Control
	Speed accuracy	±0.5%	±0.01%	
	Speed resolution	1/25000 (Digital setting)	Analog setting 1/1000. Isolation transducer recommended.	
Acceleration/deceleration time	0.1 – 3276.7 sec, acceleration/deceleration independent setting		Drive cannot regenerate	
Operation specification	Restart after instantaneous interruption	Possible (more than 5 cycles interruption causes shut down)	Under-voltage trip at 75% level	

**General Control Specifications Continued:**

General Control Specifications

Item		Standard specification	Option	Remarks
Communications	Serial interface	None	MODBUS DEVICE_NET PROFIBUS TL-S20	Requires optional board.
	Commissioning /Maintenance Tool	Ethernet (with modular jack attached to keypad)		
Cubicle display/operation	LED 1 lamp	READY: Operation preparation completed (Green) RUN: Inverter in operation (Red) ALARM/FAULT: Alarm slow flashing/Fault fast flashing	READY and RUN light colors can be reversed by changing an EIO parameter	
	LED 2 lamp	ON - Keypad control OFF - Other than keypad control		
	LCD display	128x64 Pixel Graphical LCD display		
	Operation apparatus	Backlit type interlock switch: 1 Unlit reset switch: 1 Operation via 8 key keypad and a 15pulse/30detent incremental encoder		
	Connector	Personal computer connection Ethernet modular jack		
Analog signal output		± 10VDC x 3 programmable channels on XIO board ± 10VDC x 5 programmable channels on terminal strip ± 10VDC x 2 fixed channels on terminal strip		Connected measuring equipment must be isolated from ground
Analog signal input		± 10VDC x 2 channels		Connected source equipment must be isolated from ground
Digital input/output		Input: 8 dry contact inputs 7 Programmable: 1 dry contact 24-110Vdc 48-120Vac 6 dry contact 24Vdc 1 Fixed: 1 dry contact 24-110Vdc 48-120Vac		Fixed contact is always used for interlocking control function
		Output: Programmable 1 open collector 24VDC-50mA max 5 open collector 24/50VDC-50mA max		24V contact always used for internal control functions
Commissioning and Maintenance Tool			Parameter setting, fault data display, etc.	Optional Software Package

## Rating Specifications

**NEMA Type 1 Standard Ratings Table (T300MVi)**

Standard Model	Input Voltage	Motor Hp	Output kW	Output KVA	Output Current 100%	Overload Current 110~115%-60 s.	Frame	Output Voltage & Frequency
M3A22030S	2400 V	300	233	268	64	74	0	0~2400 V 0~75 Hz
M3A22035S		350	272	313	75	86	0	
M3A22040S		400	311	357	86	99	0	
M3A22045S		450	350	402	97	111	0	
M3A22050S		500	389	447	107	124	0	
M32A22030S		300	233	268	64	74	A2	
M32A22035S		350	272	313	75	86	A2	
M32A22040S		400	311	357	86	99	A2	
M32A22045S		450	350	402	97	111	A2	
M32A22050S		500	389	447	107	124	A2	
M3A22060S		600	466	536	129	148	1	
M3A22070S		700	544	625	150	173	1	
M3A22080S		800	622	715	172	198	1	
M3A22090S		900	699	804	193	222	1	
M3A22100S		1000	777	893	215	247	1	
M32A22060S		600	466	536	129	148	B2	
M32A22070S		700	544	625	150	173	B2	
M32A22080S		800	622	715	172	198	B2	
M32A22090S		900	699	804	193	222	B2	
M32A22100S		1000	777	893	215	247	B2	
M3A22125S		1250	971	1116	269	309	3	
M3A22150S		1500	1166	1340	322	371	3	
M3A22175S		1750	1360	1563	376	432	3	
M3A22200S		2000	1554	1786	430	494	3	
M32A22125S		1250	971	1116	269	309	D2	
M32A22150S		1500	1166	1340	322	371	D2	
M32A22175S		1750	1360	1563	376	432	D2	
M32A22200S		2000	1554	1786	430	494	D2	
M3A22225S		2250	1748	2010	483	556	4	
M3A22250S		2500	1943	2233	537	618	4	
M3A22300S	3000	2331	2680	645	741	4		

Specifications subject to change without notice. Inverter performance data is based on a typical 4 pole motor operating at 0.87 pf and 0.96 efficiency.

NEMA Type 1 Standard Ratings Table (T300MVi) Continued

Standard Model	Input Voltage	Motor Hp	Output kW	Output KVA	Output Current 100%	Overload Current 110~115%-60 s.	Frame	Output Voltage & Frequency
M3A44030S	4160 V	300	233	268	37	43	0	0~4160 V 0~75 Hz
M3A44035S		350	272	313	43	50	0	
M3A44040S		400	311	357	50	57	0	
M3A44045S		450	350	402	56	64	0	
M3A44050S		500	389	447	62	71	0	
M3A44060S		600	466	536	74	86	0	
M32A44030S		300	233	268	37	43	A4μ	
M32A44035S		350	272	313	43	50	A4μ	
M32A44040S		400	311	357	50	57	A4μ	
M32A44045S		450	350	402	56	64	A4μ	
M32A44050S		500	389	447	62	71	A4μ	
M32A44060S		600	466	536	74	86	A4μ	
M3A44070S		700	544	625	87	100	0	
M3A44080S		800	622	715	99	114	0	
M3A44090S		900	699	804	112	128	0	
M3A4410ES		1000	777	893	124	136	0	
M32A44070S		700	544	625	87	100	A4	
M32A44080S		800	622	715	99	114	A4	
M32A44090S		900	699	804	112	128	A4	
M32A4410ES		1000	777	893	124	136	A4	
M3A44100S	1000	777	893	124	143	1		
M3A44125S	1250	971	1116	155	178	1		
M3A44150S	1500	1166	1340	186	214	1		
M3A44175S	1750	1360	1563	217	249	1		
M3A44200S	2000	1554	1786	248	273	1		
M32A44100S	1000	777	893	124	143	B4		
M32A44125S	1250	971	1116	155	178	B4		
M32A44150S	1500	1166	1340	186	214	B4		
M32A44175S	1750	1360	1563	217	249	B4		
M32A44200S	2000	1554	1786	248	273	B4		
M3A44225S	2250	1748	2010	279	321	2		
M3A44250S	2500	1943	2233	310	356	2		
M3A44300S	3000	2331	2680	372	409	2		
M3A44300S	3000	2331	2680	372	428	3		
M3A44350S	3500	2720	3126	434	499	3		
M3A44400S	4000	3108	3573	496	546	3		
M3A44400S	4000	3108	3573	496	570	4		
M3A44450S	4500	3497	4019	558	642	4		
M3A44500S	5000	3885	4466	620	713	4		
M3A44550S	5500	4274	4913	682	784	4		
M3A44600S	6000	4663	5359	744	818	4		
M3AP44700S	7000	5440	6252	868	998	G4P		
M3AP4480ES	8000	6217	7146	992	1091	G4P		
M3AP44800S	8000	6217	7146	992	1141	H4P		
M3AP44900S	9000	6994	8039	1116	1283	H4P		
M3AP4410KS	10000	7771	8932	1240	1426	H4P		

Specifications subject to change without notice. Inverter performance data is based on a typical 4 pole motor operating at 0.87 pf and 0.96 efficiency.

### NEMA Type 1 Standard Ratings Table (T300MVi) Continued

Standard Model	Input Voltage	Motor Hp	Output kW	Output KVA	Output Current 100%	Overload Current 110~115%-60 s.	Frame	Output Voltage & Frequency
M3AS66175S	6600 V	1750	1360	1563	137	158	B6S	0~6600 V 0~75 Hz
M3AS66200S		2000	1554	1786	156	179	B6S	
M3AS66225S		2250	1748	2010	176	321	B6S	
M3AS66250S		2500	1943	2233	195	202	B6S	
M3AS66300S		3000	2331	2680	234	269	B6S	
M3AS66350S		3500	2720	3126	273	314	C6S	
M3AS66400S		4000	3108	3573	313	360	C6S	
M3AS66450S		4500	3497	4019	352	405	D6S	
M3AS66500S		5000	3885	4466	391	450	D6S	
M3AS66550S		5500	4274	4913	430	495	F6S	
M3AS66600S		6000	4663	5359	469	539	F6S	
M3AS66700S		7000	5440	6252	547	629	F6S	
M3AS66800S		8000	6217	7146	625	719	F6S+	
M3AS66900S		9000	6994	8039	703	808	F6S+	

Specifications subject to change without notice. Inverter performance data is based on a typical 4 pole motor operating at 0.87 pf and 0.96 efficiency.

### N3R Standard Ratings Table (MTX) Continued

Standard Model	Input Voltage	Motor Hp	Output kW	Output KVA	Output Current 100%	Overload Current 110~115%-60 s.	Frame	Output Voltage & Frequency
MTXA44050SA	4160 V	500	389	447	62	71	MTX15	0~4160 V 0~75 Hz
MTXA44100SA		1000	777	893	124	136	MTX15	
MTXA44150SA		1500	1166	1340	186	214	MTX15	
MTXA44200SA		2000	1554	1786	248	273	MTX30	
MTXA44250SA		2500	1943	2233	310	356	MTX30	
MTXA44300SA		3000	2331	2680	372	428	MTX30	

Specifications subject to change without notice. Inverter performance data is based on a typical 4 pole motor operating at 0.87 pf and 0.96 efficiency.

## Protective Functions

The main protective functions are shown in the following table. For other faults or more details, refer to the troubleshooting and EOI manuals.

Protective Function Table

Item	Abbreviation	Hardware Detection	Software Detection	Heavy Fault		Medium Fault	Light Fault	Start Interlock
				Coast to stop	Decel stop	Stop request	Alarm	
Input main switch open	AC_MCCB		○	○				
No load connected	AC_NL		○	○				
Output main switch closed without signal (Welded)	ACSW_C							○
Output main switch opened during operation	ACSW_F		○	○				
Output main switch open timer	ACSW_T		○					○
Brake healthy	B_HLTY		○	○				
External trip from input breaker	BLA		○	○				
Brake release fault	BR_F		○		○			
Equipment ventilation fan stop	C_FN		○			○	○	
Equipment ventilation fan stop timer	C_FN_T		○	○				
Current limit timer	CL_T		○	○				
Current limit alarm	CL_TA		○			○		
Control power supply loss	CPSF		○	○*				
CPU error	CPU_A or M	○		○*				
U or W phase feedback error	CURU or W		○	○*				
Door open	DS_T		○	○*				
Encoder feedback error	ENCODER_F		○	○*				
Rectifier fuse fault	FUSE_xP FUSE_xN		○	○*				
Ground fault alarm	GR_A_		○			○	○	
Ground fault trip	GR_T_		○	○				
External interlock	IL		○	○				
Motor cooling fan stop timer	M_FN_T		○		○			
Motor cooling fan stop	M_FN		○			○	○	○
Motor overheat	M_OH		○	○		○	○	
Motor overheat alarm	M_OH_A		○			○	○	
Main power supply loss	MPSF		○	○*				
Main power supply loss	MPSF_MV		○	○*				
Motor temperature sensor error	MTMP_S		○			○	○	
AC over-current	OCA		○	○*				
Power Module phase over-current	OCD_x		○	○*				
Power Module IGBT over-current	OCD_xA1 OCD_xA4 OCD_xB1 OCD_xB4	○		○*				
Power Module overheat	OH_T_x		○	○*				
Transformer over heat	OH_TR		○	○*				
Overload alarm	OL_A					○	○	

Overload (5 minutes)	OL5		○	○				
Overload (20 minutes)	OL20		○	○				
Over speed	OSS		○	○*				
Output frequency high	OSS_F0		○	○*				
DC bus over-voltage positive/negative	OV_xP OV_xN		○	○*				
Panel safety switch	P_SW	○		○				
Parameter setting error	PARA_ERR		○	○				
PLL phase error	PHASE_ERR		○	○				
PLD error	PLD_ERR		○	○*				
PLL error	PLL		○	○*				
Pre-charge CTT trip	PRE_CTT		○	○				
Pre-charge CTT alarm	PRE_CTT_F					○	○	○
Rectifier failure	REC_F		○	○*				
Reverse rotation failure	REV_ROT_F		○	○*				
Rotation/start failure	ROTATE_FAIL		○	○*				
Soft stall	SOFT_STL						○	
Speed feedback error	SP_ERR		○	○*				
Speed feedback error2	SP_ERR2		○	○*				
Speed reference lost	SP_LOST		○	○	○			
Speed reference lost alarm	SP_LOST_A					○	○	○
Motor turning start interlock	SP_SIL							○
Spare input 1-4	SPA1-4		○	○*	○	○		
Spare input 1-4 timer	SPA1-4_T		○	○*	○	○		
System configuration error	SYS_ERR		○		○			
Communication error 1-4	TL_F1-4		○	○	○			
Main under-voltage	UV_MPSF		○	○				
DC under-voltage start interlock	UV_SIL		○	○				○
DC under-voltage trip	UVD		○	○				
External safety switch	UVS	○		○				
Input voltage phase loss	VAC_PH_LOSS		○	○				
Output current phase loss	VINV_PH_LOSS		○	○				

(Note 1) Hardware Detection: Items for which all IGBTs are directly turned off by hardware. Software Detection: Items for which protective interlock operation is performed by detecting errors via software.

(Note 2) "○" marks in the interlock operation fields can be selected by parameter setting.  
 "\*" indicates that the equipment outputs the trip signal to input main circuit breaker.  
 "x" indicates the phase (U,V,W).

## General Cubicle Structure

The configuration and dimensions of the equipment are described below.

## Cubicle Structure and Dimensions

The equipment is made up of one or more cabinets containing the transformer, incoming terminals, converter section, and the inverter section. All components can all be accessed from the front.

This outline is for the standard Frame 1 model. For details of this and other ratings, see the outline drawing of each product.

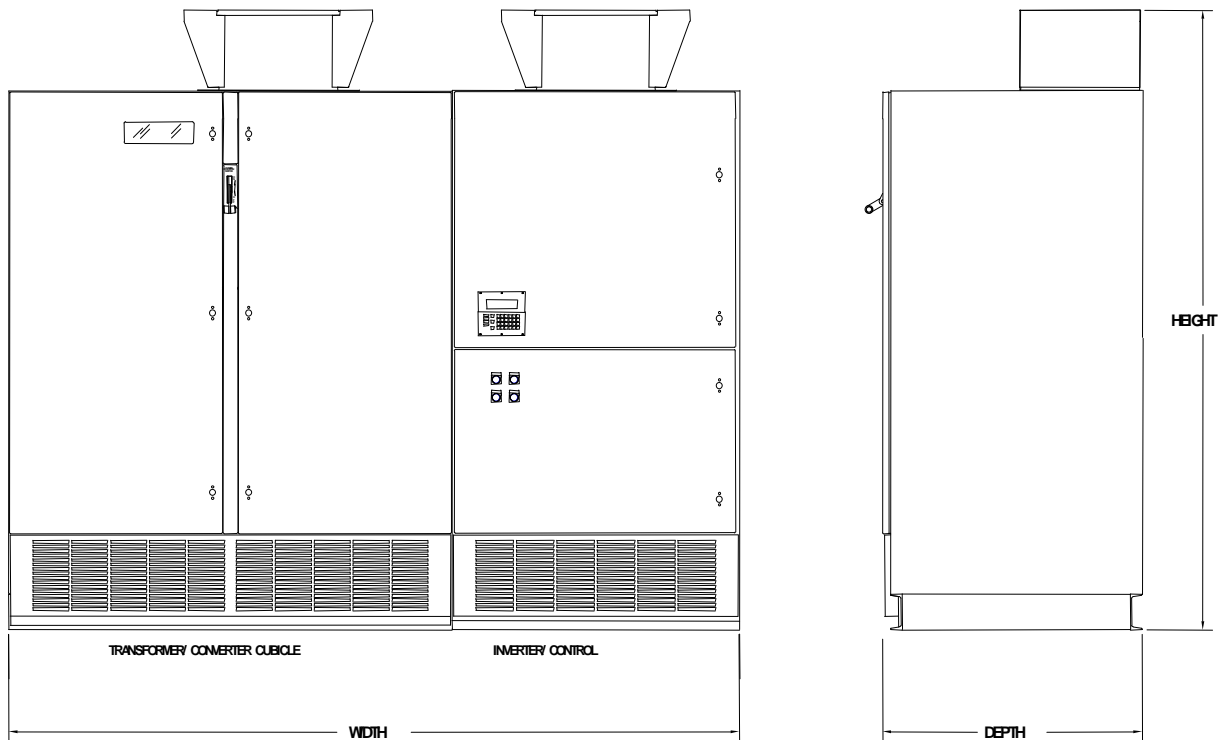

### Dimensional Outline of 4160V- Frame 1 Cubicle (See the following page for dimensions)

#### General structure

- 1) All cubicles have a structure that allows maintenance from the front. Rear maintenance access is not required. The cubicles may be placed within 1" of the rear wall. (T300MVi) Refer to the outline drawings for the MTX series as this varies with the frame size.
- 2) Provide a maintenance space of at least 72 inches (1829 mm) in front of the cubicles.
- 3) Provide a clearance of at least 24 inches (610 mm) above the exhaust fans. (T300MVi)
- 4) The following are not included in the dimensions on the next page:
  - a) Handle projections
  - b) Door mounted device projections
  - c) Fastener projections

**Dimensions and Weights of Equipment**

**Dimensions of the complete drive, including the power modules**

Standard Model Number	Dimensions – inches (mm)							
	H	W Input Sect	W Conv Sect 1	W Conv Sect 2	W Inv Sect	W Output Sect	W total	D
M3A22030-050S	103.7 (2634)	N/A	74 (1880)	N/A	*	N/A	74 (1880)	43.4 (1102)
M32A22030-050S	103.7 (2634)	N/A	48 (1219)	N/A	*	N/A	48 (1219)	48 (1219)
M3A22060-100S	103.7 (2634)	N/A	74 (880)	N/A	48 (1219)	N/A	122 (3099)	43.4 (1102)
M32A22060-100S	103.7 (2634)	N/A	74 (1880)	N/A	*	N/A	74 (1880)	43.4 (1102)
M3A22125-200S	103.7 (2634)	N/A	90 (2286)	N/A	84 (2134)	N/A	174 (4420)	49.5 (1257)
M32A22125-200S	103.7 (2634)	N/A	74 (880)	N/A	48 (1219)	N/A	122 (3099)	49.5 (1257)
M3A22250-300S	103.7 (2634)	N/A	111 (2819)	N/A	111 (2819)	N/A	222 (5639)	49.5 (1257)
M3A44030-10ES	103.7 (2634)	N/A	74 (1880)	N/A	*	N/A	74 (1880)	43.4 (1102)
M32A44030-60S	103.7 (2634)	N/A	48 (1219)	N/A	*	N/A	48 (1219)	48 (1219)
M32A44070-10ES	103.7 (2634)	N/A	60 (1524)	N/A	*	N/A	48 (1219)	48 (1219)
M3A44100-200S	103.7 (2634)	N/A	74 (1880)	N/A	48 (1219)	N/A	122 (3099)	43.4 (1102)
M32A44100-200S	103.7 (2634)	N/A	90 (2286)	N/A	*	N/A	90 (2286)	48 (1219)
M3A44225-30ES	103.7 (2634)	N/A	90 (2286)	N/A	74 (1880)	N/A	164 (4166)	49.5 (1257)
M3A44300-40ES	103.7 (2634)	N/A	90 (2286)	N/A	84 (2134)	N/A	174 (4420)	49.5 (1257)
M3A44400-600S	103.7 (2634)	N/A	111 (2819)	N/A	111 (2819)	N/A	222 (5639)	49.5 (1257)
M3AP44700-80ES	103.7 (2634)	51 (1295)	118.5 (3010)	N/A	90 (2286)	48 (1219)	307.5 (7811)	60 (1524)
M3AP44800-10KS	103.7 (2634)	51 (1295)	92.5 (2350)	100 (2540)	111 (2819)	48 (1219)	402.5 (10224)	60 (1524)
M3AS66175-300S	103.7 (2634)	30 (762)	74 (1880)	N/A	48 (1219)	24 (610)	176 (4470)	48 (1219)
M3AS66350-400S	103.7 (2634)	36 (914)	100 (2540)	N/A	74 (1880)	24 (610)	234 (5944)	60 (1524)
M3AS66450-500S	103.7 (2634)	36 (914)	100 (2540)	N/A	90 (2286)	24 (610)	265 (6731)	60 (1524)
M3AS66550-700S	103.7 (2634)	51 (1295)	118.5 (3010)	N/A	111 (2819)	24 (610)	304.5 (7734)	60 (1524)
M3AS66800-900S	103.7 (2634)	51 (1295)	92.5 (2350)	100 (2540)	111 (2819)	24 (610)	378.5 (9614)	60 (1524)
MTXA44050-150S	107.2 (2723)	N/A	84 (2134)	N/A	97 (2464)	N/A	181 (4597)	63 (1600)
MTXA44200-300S	107.2 (2723)	N/A	104 (2642)	N/A	133.5 (3391)	N/A	237.5 (6033)	72 (1829)

**Dimensions and weights of equipment (cont'd)**

Weights of the complete drive, including the power modules

Standard Model Number	Weight Input lbs (kg)	Weight Conv1** lbs (kg)	Weight Conv2** lbs (kg)	Weight Inv** lbs (kg)	Weight Output lbs (kg)
M3A22030-050S	N/A	6000 (2727)	N/A	*	N/A
M32A22030-050S	N/A	5500 (2500)	N/A	*	N/A
M3A22060-100S	N/A	6500 (2949)	N/A	2500 (1134)	N/A
M32A22060-100S	N/A	8600 (3909)	N/A	*	N/A
M3A22125-200S	N/A	10500 (4763)	N/A	4500 (2041)	N/A
M32A22125-200S	N/A	10000 (4545)	N/A	2800 (1273)	N/A
M3A22250-300S	N/A	13000 (5897)	N/A	6000 (2722)	N/A
M3A44030-10ES	N/A	8000 (3636)	N/A	*	N/A
M32A44030-60S	N/A	6600 (3000)	N/A	*	N/A
M32A44070-10ES	N/A	7600 (3447)	N/A	*	N/A
M3A44100-200S	N/A	10500 (4763)	N/A	2500 (1134)	N/A
M32A44100-200S	N/A	12500 (5681)	N/A	*	N/A
M3A44225-30ES	N/A	12800 (5818)	N/A	4500 (2041)	N/A
M3A44300-40ES	N/A	14300 (6500)	N/A	6000 (2722)	N/A
M3A44400-600S	N/A	24000 (10909)	N/A	6300 (2858)	N/A
M3AP44700-80ES	3000 (1364)	25500 (11591)	N/A	8300 (3772)	3000 (1364)
M3AP44800-10KS	3100 (1409)	20500 (9318)	20500 (9318)	9600 (4364)	3500 (1591)
M3AS66175-300S	1400 (636)	12500 (5682)	N/A	3900 (1773)	1000 (455)
M3AS66350-400S	1800 (818)	18000 (8182)	N/A	6000 (2727)	1500 (682)
M3AS66450-500S	3000 (1364)	20000 (9090)	N/A	7500 (3409)	1700 (773)
M3AS66550-700S	3000 (1364)	23000 (10545)	N/A	9500 (4318)	2000 (909)
M3AS66800-900S	3000 (1364)	16000 (7273)	16000 (7273)	9500 (4318)	2000 (909)
MTXA44050-150S	N/A	10000 (4545)	N/A	5000 (2273)	N/A
MTXA44200-300S	N/A	18000 (8182)	N/A	6500 (2955)	N/A

“\*” Inverter and converter sections combined into one cubicle.

“\*\*\*” Maximum weight for the frame size with the standard transformer and no options. Consult the factory for weights for non-standard inverters, as they are job specific.

**Dimensions and weights of equipment (cont'd)**

**Dimensions and weights of the inverter power modules for T300MVi drives**

Drive Model Number	Module Voltage Class	Module Dimensions – inches (mm)			Weight lbs (kg)
		Width	Depth	Height	
M3A22030-050S	2400	9.6 (244)	27.0 (686)	24.2 (615)	120 (54)
M32A22030-050S	2400	6.6 (168)	15.4 (391)	21.0 (533)	31 (14)
M3A22060-100S	2400	11.6 (295)	30.2 (767)	31.6 (803)	235 (107)
M32A22060-100S	2400	9.9 (251)	26.8 (681)	11.1 (282)	71 (32)
M3A22125-200S	2400	24.0 (610)	38.0 (965)	35.3 (897)	512 (232)
M23A22125-200S	2400	13.3 (338)	24.7 (627)	12.8 (325)	105 (48)
M3A22250-300S	2400	31.2 (792)	35.4 (899)	38.6 (980)	650 (295)
M3A44030-10ES	4160	9.6 (244)	27.0 (686)	24.2 (615)	140 (64)
M32A44030-60S	4160	7.1 (181)	31.8 (808)	24.1 (613)	120 (55)
M32A44070-10ES	4160	9.6 (244)	27.0 (686)	24.2 (615)	140 (64)
M3A44100-200S	4160	11.6 (295)	30.2 (767)	31.6 (803)	260 (118)
M32A44100-200S	4160	11.6 (295)	30.2 (767)	31.6 (803)	260 (118)
M3A44225-250S	4160	16.7 (424)	35.4 (899)	38.6 (980)	400 (181)
M3A44300-350S	4160	24.0 (610)	38.0 (965)	35.3 (897)	580 (263)
M3A44400-600S	4160	31.2 (792)	35.4 (899)	38.6 (980)	800 (363)
M3AP44700S	4160	24.0 (610)	38.0 (965)	35.3 (897)	580 (263)
M3AP44800-10KS	4160	31.2 (792)	35.4 (899)	38.6 (98)	800 (363)
M3AS66175-300S	2400	11.6 (295)	31.4 (798)	31.6 (803)	265 (120)
	4160	11.6 (295)	33.0 (838)	31.6 (803)	290 (132)
M3AS66350-400S	2400	16.7 (424)	35.4 (899)	38.6 (980)	280 (127)
	4160	16.7 (424)	35.4 (899)	38.6 (980)	400 (181)
M3AS66450-500S	2400	24.0 (610)	38.0 (965)	35.3 (897)	512 (233)
	4160	24.0 (610)	38.0 (965)	35.3 (897)	580 (263)
M3AS66550-900S	2400	15.7 (399)	35.4 (899)	38.6 (980)	329 (150)
	4160	31.2 (792)	35.4 (899)	38.6 (980)	800 (363)

## INTERFACE

The interface between the drive system and external devices is divided into two categories: power supply system and control system.

### Power Supply Interface and Ground

The standard power supplies required are the main circuit input of 2400/4160V 3~ and (optional) control power supplies of 120V 1~ and AC480V 3~.

The following figure shows a recommended grounding circuit for the related equipment. Grounding is intended not only for safety but also to reduce noise problems. The control ground bus is mounted on insulated standoffs. It may be separated from the power ground and run separately to the earth ground with insulated cable if noise problems are encountered with auxiliary control devices.

**Grounding must follow local and national codes** by attaching a properly sized ground conductor to the drive equipment.

#### Recommended Ground Circuit

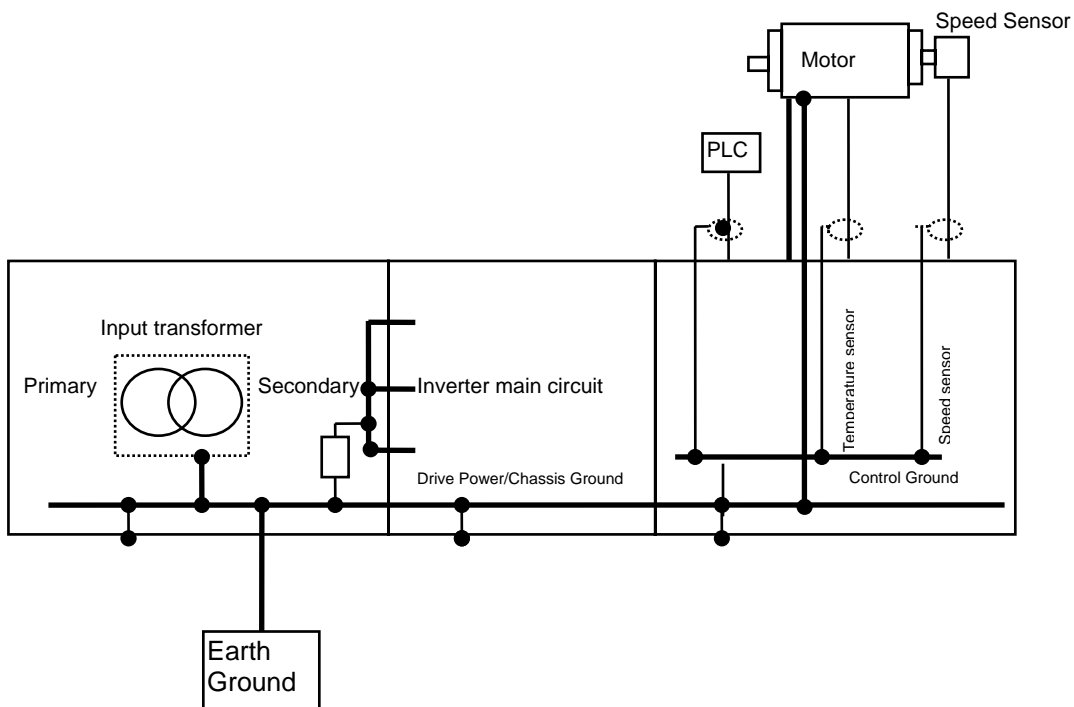

#### Grounding

## INTERFACE (cont'd)

### Motor Interface

If armored and shielded cables are to be used, be sure to connect the shield drain or armor to the ground bus provided in the drive equipment near the output terminals (U, V, W). It is not recommended that both ends be grounded. Ensure that the motor is connected properly at the junction box and properly insulated to protect against accidental shorting or grounding.

### Speed Sensor Interface (Option)

In addition to open loop control, it is also possible to use a speed sensor to perform high precision speed control. Speed sensor selection explained below

### Resolver

The drive is capable of accepting both 1x and 4x resolver feedback. The excitation can be either 1 or 4kHz. For resolver feedback, the following parameters need to be set:

CS\_RES\_TYPE=1or4 (Set to match the resolver)  
CS\_PG\_OUT= Set to desired PG output count. (Minimum setting for resolver use is 64)  
(See parameter manual for exact settings)  
CS\_PG\_CNT=64  
FLG\_RES\_EX4= 0 for 1kHz, 1 for 4kHz

### PG (Pulse Generator)

This drive can only read single ended PG signals. The maximum frequency that the PG input can read is 10kHz. The PG should be selected so that this limit is never exceeded. It is recommended that a 10% margin be allowed for overspeed. The following is an example of how to select your PG.

PG pulse count (ppr) = (maximum frequency $\times$ 0.9) / (application top motor speed ( $\text{min}^{-1}$ ) / 60)

<Example> When 100% speed is  $1800 \text{ min}^{-1}$   
Max PG pulse count =  $(10000 \times 0.9) / (1800 / 60) = 300 \text{ ppr}$   
Therefore, PG of 300 ppr or less is used.

The following settings should be used:

CS\_RES\_TYPE=1  
CS\_PG\_OUT=0  
CS\_PGCNT = 256 (Set to the PPR of the PG.)

## INTERFACE (cont'd)

### Pulse Signal Output

If a speed sensor is used, speed feedback signals can be output as pulse signals. The PG pulse output circuit is shown in the following figure. The power supply for the pulses should be supplied from an outside source in a range of 12 V to 24 V. The number of pulses per revolution output can be set using the parameter CS\_PGOUT when a resolver is used. See the parameter setting manual for exact settings. Otherwise, set to zero when using a PG. With a PG, the number of pulses out equals the number of pulses in. **This output is limited to 10kHz.**

The PG pulse output consists of two phases of PGA and PGB at 90° separation. These pulse signals (at the level of the power supplied from an outside source) are isolated from the control power supply of the drive through photo-couplers.

#### Pulse Output Circuit

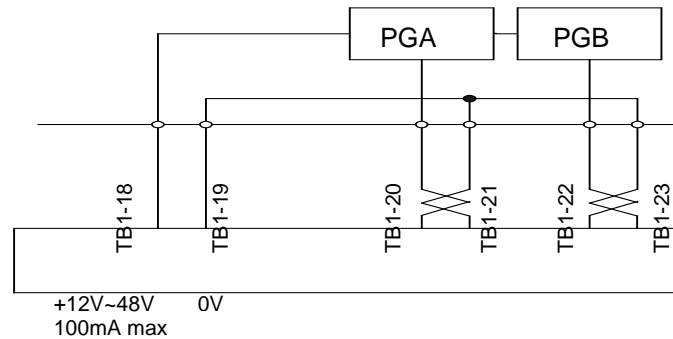

### Digital Input

A total of 7 programmable digital inputs (DI1 to DI7) are provided. Only DI1 is capable of accepting an external voltage input (24VDC) DI2-7 are hard connected to the drive's internal 24VDC power supply and should only be connected to dry contacts. These input signals can be individually assigned to bits in the DI\_EX1, 2, 3, or 4 words. The available input assignments are shown below. For more detail refer to the parameter setting manual.

Digital Input Options

Bit	DI_EX1	DI_EX2	DI_EX3	DI_EX4	DI_EX5
15	IL	NU	QSTOP	MV_JOG_B3	RATE_CHG
14	UVS	NU	UVS	MV_JOG_B2	NU
13	EXT0	NU	EXT0	MV_JOG_B1	NU
12	SPA1	SPA4	NU	MV_JOG_B0	NU
11	BRTST	SPA3	NU	EX_LMT_I1	NU
10	ST	SPA2	ST	EX_LMT_TR	NU
9	F	BLA	F	SP_UP_DI	NU
8	R	M_FN	R	SP_DN_DI	NU
7	3S	OH_ACL	3S	SEL_DI	NU
6	2S	E_DRIVE	2S	DIR0_DI	NU
5	B	HOLD	NU	DIR1_DI	ASD
4	FLD	QSTOP	FLD	START0_DI	IM_MUN_B1
3	BC	F_LMT	LATCH_PG_POS	START1_DI	IM_NUM_B0
2	SPA0	R_LMT	SPA0	STOP0_DI	XFR_CHK
1	EXRST	B_HLT	EXRST	STOP1_DI	CPT
0	R_TEN	BA	R_TEN	EXT1	XFR

“\*\*” Not used “\*\*\*” Available with 03C and up software only

## INTERFACE (cont'd)

### Digital Input Descriptions \*\*

Name	Description	Description
ASD	Adjustable speed drive	Start stop command for sync- transfer operation
B	Brake release command issued	1:Brake release sent, 0:Brake release not sent (Use when open command sent by other equipment)
BA	Brake answer back	1: Brake is open, 0: Brake is closed
BC	Brake closed	1: Brake function normal, 0:Brake forced closed
BLA	Input breaker state	0:Breaker open, 1:Breaker closed (“a” aux contact)
BRTST	Brake test	1:Brake forced open, 0:Brake function normal
B_HLTY	Brake healthy	1:Healthy, 0:Not healthy
CPT	Capture command	Used for sync-capture.
DIR0_DI	Direction select 0	0:Forward, 1:Reverse
DIR1_DI	Direction select 1	(Operates only when keypad is in remote mode.)
EXRST	External reset	1:External reset (Momentary input must be used) 0:No reset
EXT0	Two wire start/stop 0	1:Start, 0: Stop (Refer to SEL_DI)
EXT1	Two wire start/stop 1	1:Start, 0: Stop (Refer to SEL_DI)
EX_LMT_I1	Total output current limit selection	0:Use LMT_I1, 1:Use LMT_I1_EX
EX_LMT_TR	Torque reference limit selection	0:Use LMT_TRQ & LMT_TRQ_INV 1:Use LMT_TRQ_EX & LMT_TRQ_INV_EX
E_DRIVE	Drive emergency command	0:Normal operation, 1:Emergency operation
F	Forward jogging command	(F,R)=(1,0) :Forward jogging start (F,R)=(0,0) :Forward jogging stop (F,R)=(0,1) :Reverse jogging start (F,R)=(0,0) :Reverse jogging stop (F,R)=(1,1) :First received jogging start (EXT must be off)
R	Reverse jogging command	See above
FLD	Field current command	1:Field current on when READY 0:Field current off until start command received
F_LMT	Forward speed limit	1:Use LMT_SP_F, 0:Set forward speed limit to 0
R_LMT	Reverse speed limit	1:Use LMT_SP_R, 0:Set reverse speed limit to 0
HOLD	Emergency speed hold	0:Normal operation, 1:Maintain speed reference
IL	Interlock	1:Interlock released, 0: Interlocked
IM_NUM_B0	Motor selection bit 0	Used when operating motors of different ratings
IM_NUM_B1	Motor selection bit 1	Used when operating motors of different ratings
LATCH_PG_POS	Latch the PG/shaft position input	Stores the PG/shaft position at the time the input goes to 1 in PG_POS_RLATCH and in PG_POS_FLATCH at the time the input goes to 0.
MV_JOG_B3	Speed select bit 3	(B3,B2,B1,B0)=(0000): Speed0 select (B3,B2,B1,B0)=(0001): Speed1 select (B3,B2,B1,B0)=(0010): Speed2 select (B3,B2,B1,B0)=(0011): Speed3 select (B3,B2,B1,B0)=(0100): Speed4 select (B3,B2,B1,B0)=(0101): Speed5 select (B3,B2,B1,B0)=(0110): Speed6 select (B3,B2,B1,B0)=(0111): Speed7 select (B3,B2,B1,B0)=(1000): Speed8 select (B3,B2,B1,B0)=(1001): Speed9 select (B3,B2,B1,B0)=(1010): Speed10 select (B3,B2,B1,B0)=(1011): Speed11 select (B3,B2,B1,B0)=(1100): Speed12 select (B3,B2,B1,B0)=(1101): Speed13 select (B3,B2,B1,B0)=(1110): Speed14 select (B3,B2,B1,B0)=(1111): Speed15 select (Used in conjunction with F and R inputs and CR_SP0-15)
MV_JOG_B2	Speed select bit 2	
MV_JOG_B1	Speed select bit 1	
MV_JOG_B0	Speed select bit 0	

M_FN	Motor cooling fan state	1:Cooling fan running, 0:Cooling fan stopped
NU	Not used	Do not use
OH_ACL	AC reactor overheat	1:Not overheated, 0:Overheated
QSTOP	Quick stop command	1:Quick stop, 0:Normal stop
R-TEN	Reverse tension command	1:Reverse tension control on, 0:Forward tension control on
RATE_CHG	Acell Decell rate change	0: Use standard rate 1: Use OP rate
SEL_DI	Start/Stop/Reference/direction select	0:Use EXT0,START0,STOP0,SP_REF_AIN1,DIR0_DI 1:Use EXT1,START1,STOP1,SP_REF_AIN2,DIR1_DI
SPA0	Spare 0	Spare 0 (For future use)
SPA1	Spare 1	Spare 1
SPA2	Spare 2	Spare 2
SPA3	Spare 3	Spare 3
SPA4	Spare 4	Spare 4
SP_UP_DI	Raise speed reference	0:no change, 1:Raise speed reference (Operates only when keypad is in remote mode. Use in conjunction with CR_RATE_MRH)
SP_DN_DI	Lower speed reference	0:No change, 1:Lower speed reference (Operates only when keypad is in remote mode. Use in conjunction with CR_RATE_MRH)
START0_DI	Start command for three wire control 0	0:No start, 1:Start
START1_DI	Start command for three wire control 1	(Must be momentary. Refer to SEL_DI)
STOP0_DI	Stop command for three wire control 0	0:No stop, 1:Stop
STOP1_DI	Stop command for three wire control 1	(Refer to SEL_DI)
ST_CLUTCH	Torque control selection	1:Tension control, 0: Speed control (when torque control is selected)
UVS	Operation interlock	1:Interlock released, 0: Interlocked
3S	3 <sup>rd</sup> jogging speed command	(3S, 2S)=(0,0) :Jog speed 1 used
2S	2 <sup>nd</sup> logging speed command	(3S, 2S)=(0,1) :Jog speed 2 used (3S, 2S)=(1,0) :Jog speed 3 used (3S, 2S)=(1,1) :No jog speed used
XFR	Transfer command	Used for sync-transfer.
XFR_CHK	25 relay input	May be used for 25 relay input. Currently not used.

“\*\*\*” The function of many operation signals can be reversed via sign bit settings if needed.

## INTERFACE (cont'd)

### Digital Output

There are 6 programmable digital outputs (DO0-5). DO5 is used internally for control of the input contactor and should not be changed. The other 5 outputs are available for optional control or indication functions. These relays can be programmed to any bit in any word in the drive. The most commonly used bits can be found in the SSEQ\_OUT1 and SSEQ\_OUT2 words. The word assignment is made via DO0\_AS - DO4\_AS parameters. The bit number is set via DO0\_BN – DO4BN.

### Analog Input

The drive has two general-purpose analog input channels (AIN1, AIN2). They are fixed at  $\pm 10$ VDC. The analog signals are converted to digital values through a 12-bit A/D converter. A  $\pm 10$  Vdc input is converted to counts by software and is stored in the target data register. Since this signal is directly connected to the control circuit, it is recommended that an isolation transducer be used. The data register, the gain and the offset are set with the following parameters:

AIN#_AS	Target register – set by symbol name
AIN#_GS	Gain setting – defines the number of counts for 10V input
AIN#_OS	Offset setting – offsets the input

The "#" of each parameter name denotes the AD channel number. The following figure shows the input circuit:

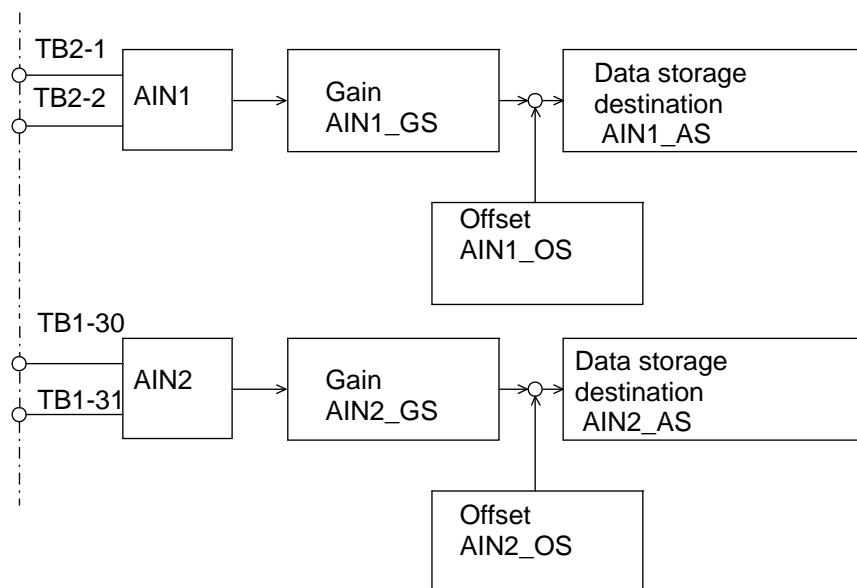

**Analog Input Circuit**

## INTERFACE (cont'd)

[Setting examples]

- **Example 1:** When a 0~8V (0 to 100%) speed reference is input to AIN1.

Set the input jumpers as per the drawings for single ended voltage input.

Set a 0 to 100% (count 0 to 25000) speed reference signal at 0 to +8 V so that it is stored in SP\_REF\_AIN1.

The input characteristic is shown in the right hand figure.

Set as follows:

AIN1\_GS =  $[25000\text{count} \times 10\text{v}/(10\text{v}-2\text{v})] = 31250$   
 AIN1\_OS = 0  
 AIN1\_AS = SP\_REF\_AIN1 or 2  
 AIN1\_TYPE = 1

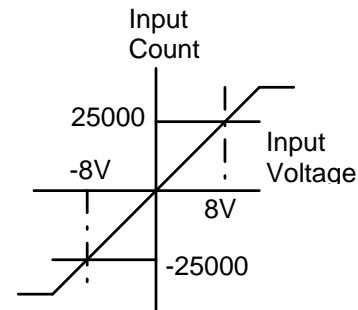

### Input Characteristic Example

**Example 2** When a 4~20 mA (0 to 100%) speed reference is input to AIN1, it is recommended that a 4-20mA/0-10VDC transducer be used. If the source is isolated, a 510Ohm burden resistor may also be used. This would give 2V at 4mA. In this case an offset would need to be set in the drive as follows:

AIN1\_GS =  $[25000\text{count} \times 10\text{v}/(10\text{v}-2\text{v})] = 31250$   
 AIN1\_OS =  $-[31250\text{counts} \times 2\text{v}/10\text{v}] = -6250$   
 AIN1\_AS = SP\_REF\_AIN1 or 2  
 AIN1\_TYPE = 1

When using 4-20mA input and a burden resistor, it is possible that the reference will become negative if the input falls below 4mA. If this happens, the drive could run in reverse. To stop this, the reverse speed limit (LMT\_SP\_R) should be set to zero, if possible. If this can not be done due to the need for reverse jogging, the parameter LMT\_SP\_MIN should be set to 0 or higher. This limit fixes the speed reference from the keypad or the analog inputs to a minimum value.

## Analog Output

### General-purpose Analog Output

Three channels (AOUT1, 2, and 3) are provided as general-purpose,  $\pm 10\text{VDC}$  analog output from the XIO board. These outputs are directly output from the control board. The device reading these signals must be isolated. To insure this, it is recommended that signal isolators be used. The output can be selected from a list shown in the parameter setting manual by using the parameters AOUT1-3\_CODE. They may also be set to any function in the drive by the use of the parameters AOUT1-3\_OP\_AS, AOUT1-3\_OP\_GS, and AOUT1-3\_OP\_OS. When using the optional settings, care must be taken to set the output up so that the output signal does not exceed  $\pm 10\text{V}$ . Exceeding this value will cause overflow problems.

## INTERFACE (cont'd)

### Additional Analog Outputs

Six channels (D/A1 to D/A5 and Amp A) are provided as additional analog outputs. These outputs are wired out to terminal block TB-AO. Channel A is direct current feedback from the U phase Hall CT. The other five channels are programmable  $\pm 10\text{VDC}$  outputs. The data to be output, the gain, and the offset, can be set from the display/keypad or a personal computer by use of the parameters DA1-5\_AS, DA1-5\_GS, and DA1-5\_OS.

### Motor Mounted Fan Circuit

A main motor may require a motor mounted blower fan circuit as an option. When using an external motor fan, be sure to check the rotation direction of the fan and change its phase rotation if necessary.

You can make a fan interlock for the operation of the drive by connecting an "a" auxiliary contact of the fan MCCB/starter to one of the digital inputs on the XIO board and programming it as M\_FAN.

This function is available in drives with 03C and up software versions only. If the drive has software version 03A, one of the spare inputs must be used instead.

**CIRCUIT OPERATION**

**Main Circuit Configuration**

The following circuit shows some typical configurations of the T300MVi drive. Input AC is supplied through an input controller to transformer T1. The transformer has multiple phase shifted secondaries connected to full wave diode rectifier bridges. The output of the rectifiers is connected to three inverter power modules that produce 3-phase AC power at the frequency and voltage required by the motor. For 6600V drives, a combination of three 2400V modules and three 4160V modules are used in series to produce 6600V.

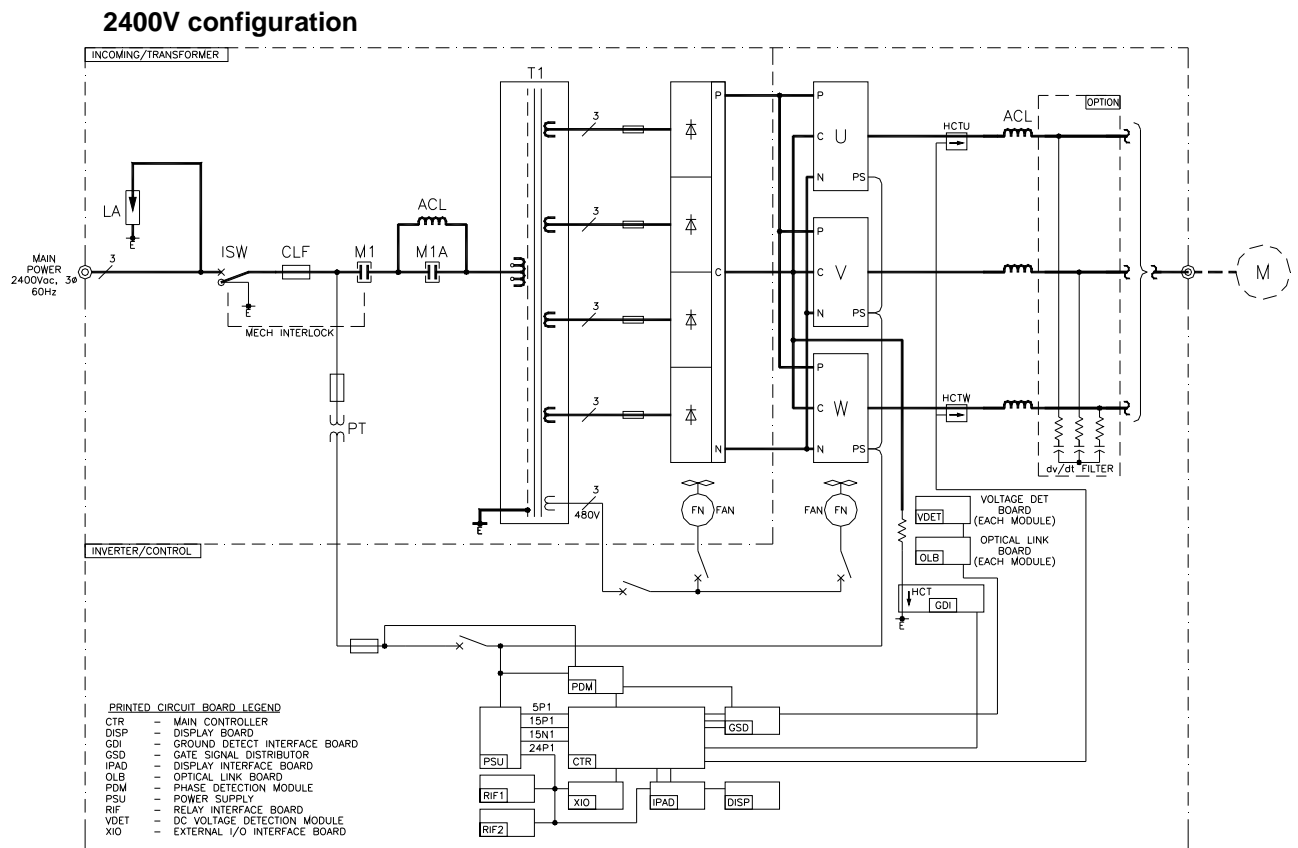

## CIRCUIT OPERATION (cont'd)

### 4160V configuration

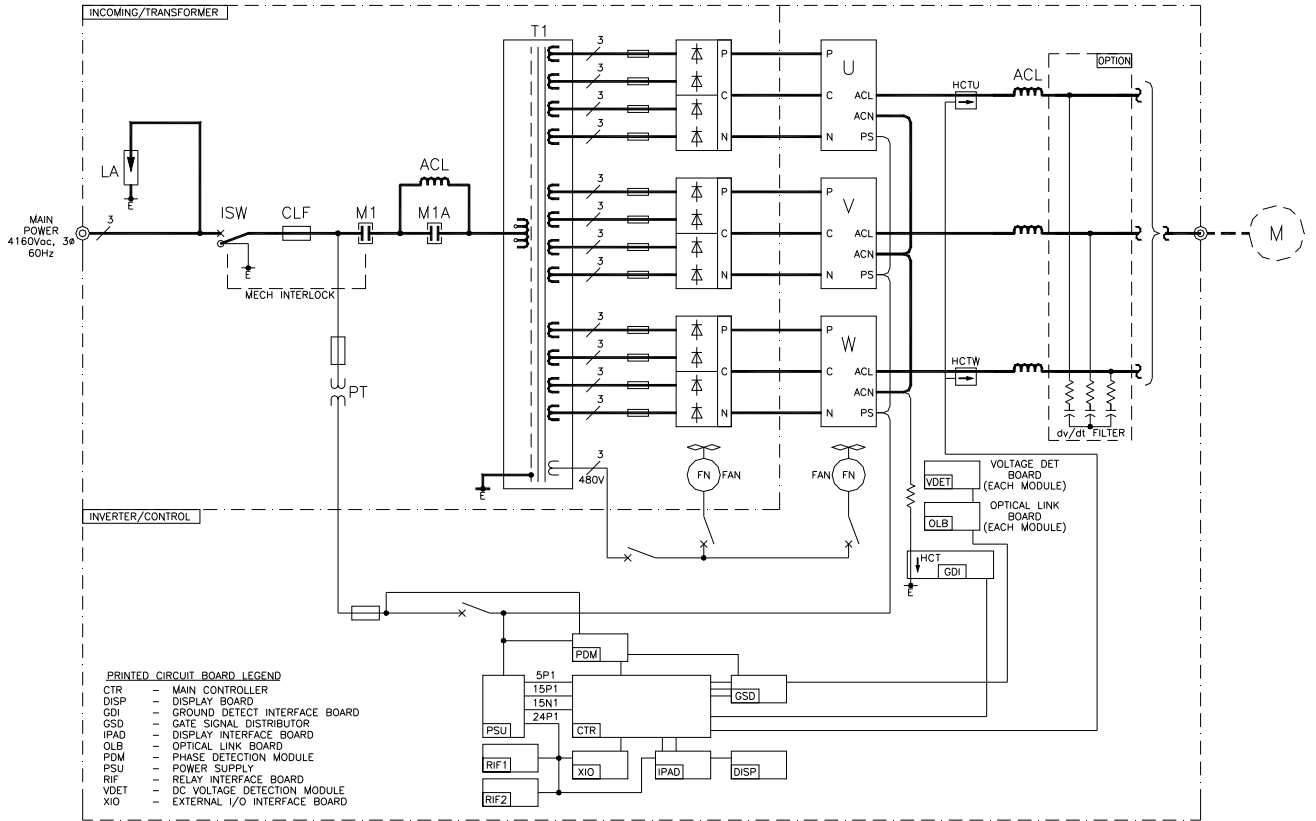

## CIRCUIT OPERATION (cont'd)

### 6600V configuration

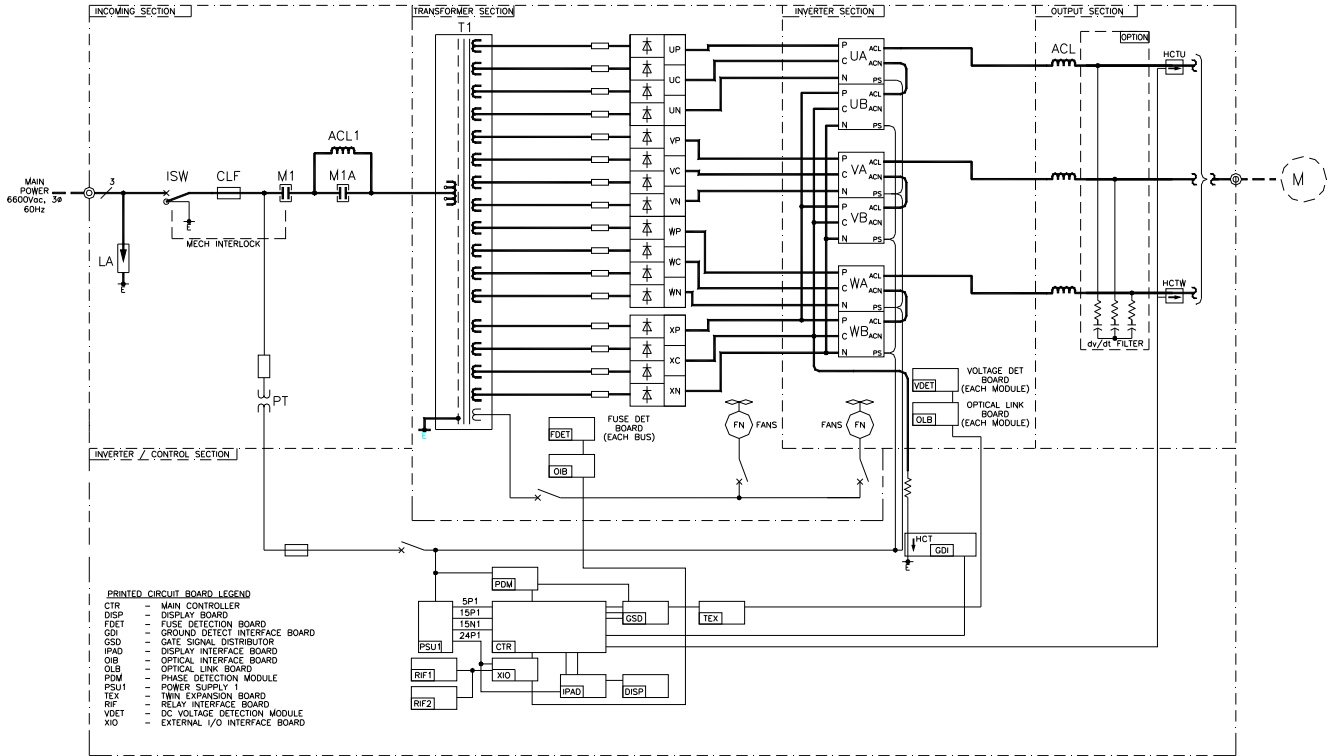

**CIRCUIT OPERATION (cont'd)**

The AC output voltage of the each inverter power module, for the 4160V drive, is 2400V line to neutral. With phase voltages shifted 120° from one other, an output voltage of 4160V between phases is generated. The output voltage closely approximates a sine wave. This is shown in the output waveform below. This produces a sine wave motor current with low distortion.

**Generation of High Voltage by Wye Connection**

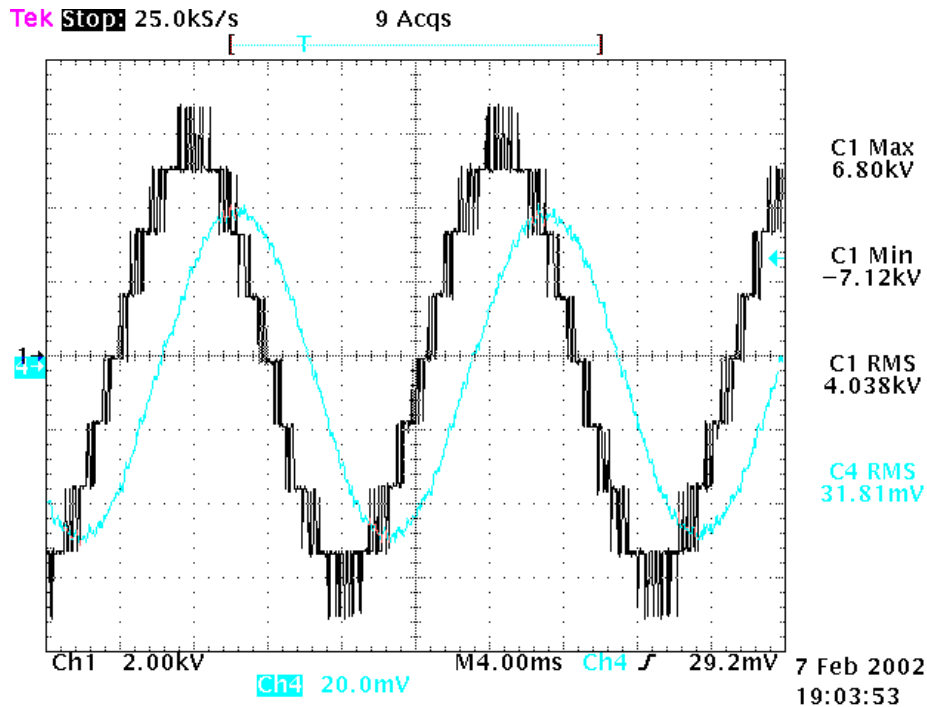
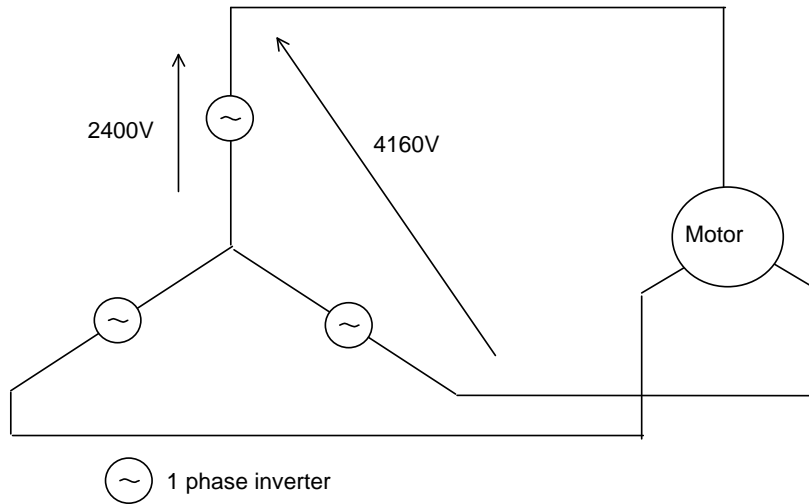

**Output Voltage and Current Waveforms**

**CIRCUIT OPERATION (cont'd)**

**Control**

The following figures show the overall T300MV/MTX Control block diagrams for IM (Induction Motor) control.

**Vector Control Block Diagram**

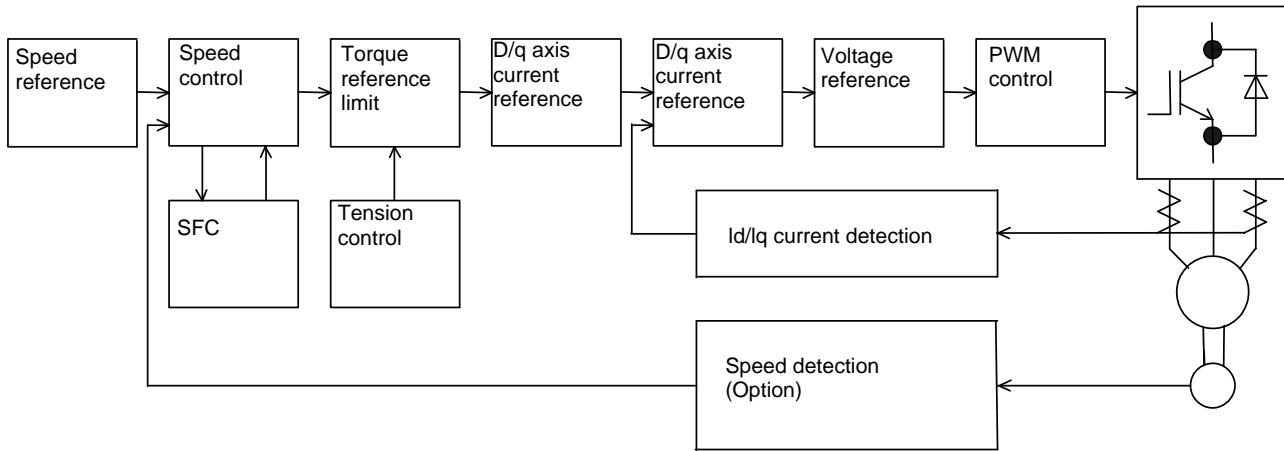

**V/f Control Block Diagram**

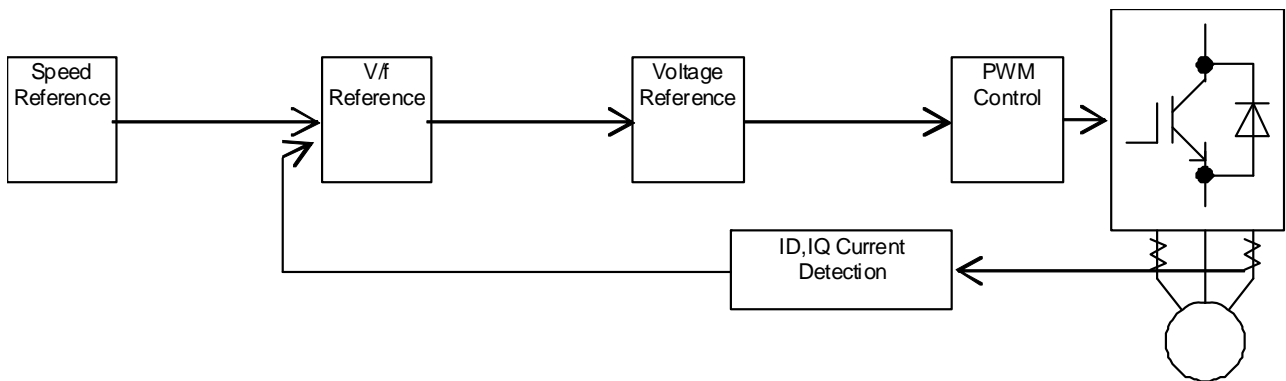

**CIRCUIT OPERATION (cont'd)**

**Speed Reference**

An external speed reference with count 25000/100% weighting is input by serial transmission or analog input and subjected to rate processing and limit processing to output an SP\_R signal. The sign of the speed reference signal is "+" for normal rotation and "-" for reverse rotation.

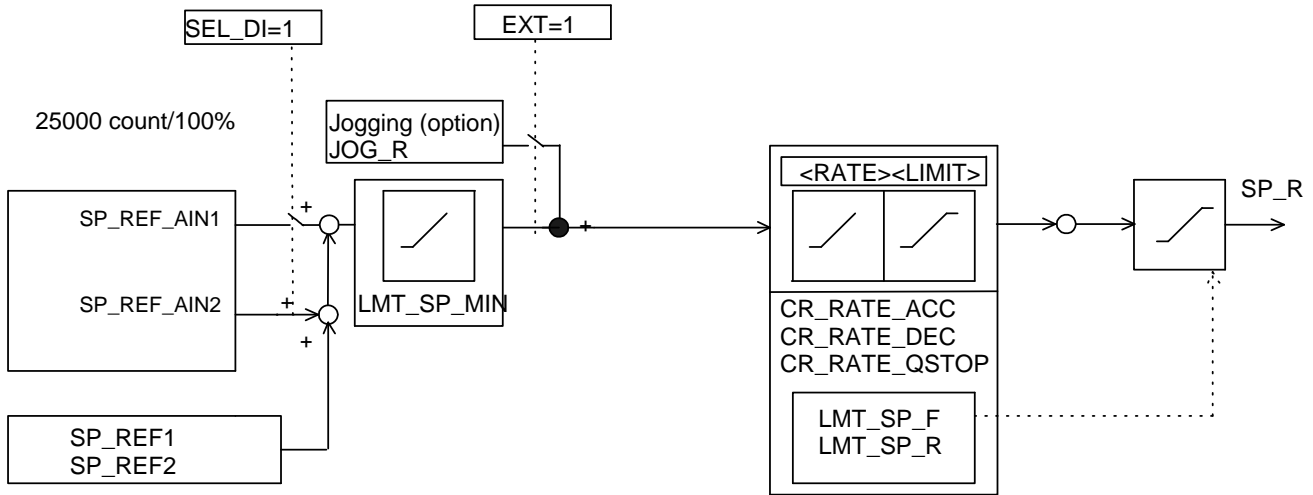

**Speed Reference**

(1) Speed references

SP\_REF1 or SP\_REF2 can be used when the drive speed is to be controlled from one location only. When using local and remote control or there is a need for selection between two separate inputs SP\_REF\_AIN1 and SP\_REF\_AIN2 should be used. To select between references, one of the digital inputs should be programmed as SEL\_DI and the selection switch connected.

SP\_REF\_AIN1 is used when the SEL\_DI input is 0 (Open). SP\_REF\_AIN2 is used when SEL\_DI is 1 (Closed). The start commands (EXT) are also different for this application. When SEL\_DI is 0, EXT0 should be used and when SEL\_DI is 1, EXT1 should be used.

(2) LMT\_SP\_MIN

LMT\_SP\_MIN is used as a minimum speed. The drive will run at this speed anytime the start command is on and the speed reference is less than LMT\_SP\_MIN.

**CIRCUIT OPERATION (cont'd)**

**Vector Control Speed Control**

The following figure shows the speed control block diagram.

The speed reference signal SP\_R and the filtered speed feedback are input and the deviation between these two is subjected to proportional/integral operations and output. After this signal is subjected to torque filtering and torque limit processing, a torque reference SFC\_T\_R is output.

Control response is performed with the following parameter settings.

- ASPR\_A: Anti-overshoot gain
- ASPR\_AT: Anti-overshoot gain time constant
- ASPR\_P: Proportional gain
- ASPR\_W1: Response target

Note that if the  $GD^2$  of the machine is extremely large compared to  $GD^2$  of the motor or if there is torsional resonance, the control response may need to be slow.

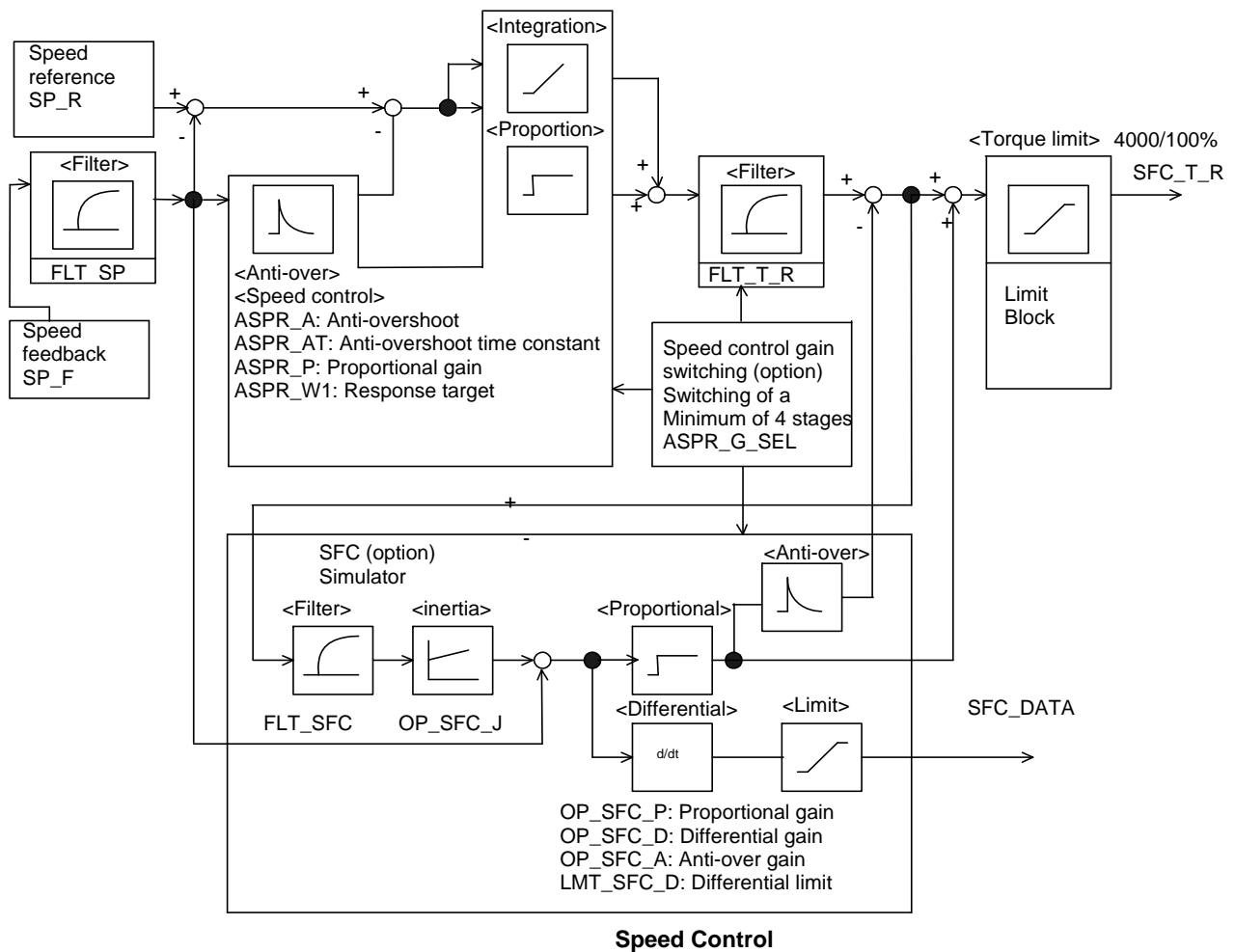

**CIRCUIT OPERATION (cont'd)**

**Vector Control Simulator Follower Control (SFC, optional control used with a speed sensor)**

When the machine has torsional resonance, the (SFC) function may be used to try to reduce the torsional vibration and increase the speed response.

With SFC, the speed regulator output signal is input to an inertia compensation block. This block produces an estimated speed signal. The speed feedback is then subtracted from this value to create a speed deviation signal. This signal is then sent through a proportional block and added to the output of the speed regulator. The speed deviation signal is also sent through an anti-overshoot block and subtracted from the speed regulator output. The combination of these two functions can be used to help improve the recovery of the system during shock loading.

The speed deviation signal is also sent to a differential block and added to the torque reference (see below). This signal is effective for torsional vibration control. When the SFC function is not used, set all of the gains to 0.

**Vector Control Torque Reference and Current Reference**

Signal SFC\_T\_R, the result of speed control, which is equivalent to the torque reference is input and subjected to torque limit operation and di/dt processing. The differential output of the SFC control is then added (if used). This is the torque reference that is sent to the current regulator.

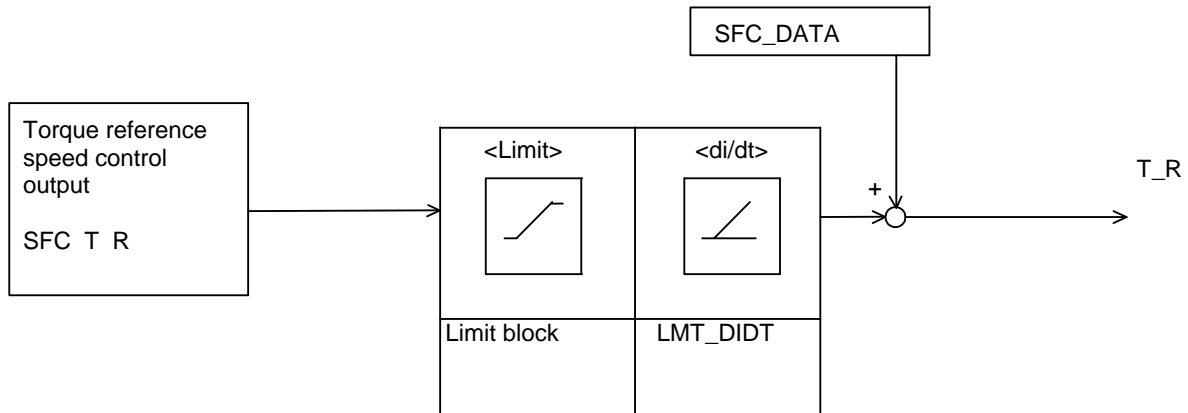

**Torque Reference**

**CIRCUIT OPERATION (cont'd)**

**Vector Control IQ Limit (Torque current limit)**

The IQ limit has a flat characteristic from 0 to base speed and tapers from base to top speed. The following settings are used to adjust the limits.

- LMT\_IQ\_BAS: Base speed torque current limit. Set 110%, 115%, etc. according to OL specification of the drive.
- LMT\_IQ\_TOP: Top speed torque current limit. Set as required by the application or set the same as the base limit when field weakening is not used.
- LMT\_IQ\_INV: Regeneration torque current limit. Set to 1 or 2%. This Drive cannot regenerate.
- LMT\_SP\_BASE: The upper speed of the drive at which LMT\_IQ\_BASE is used. Set 125% for applications that do not use field weakening. Otherwise set as required by the application.
- LMT\_TRQ: Torque reference motoring absolute limit. The maximum motoring torque reference allowed regardless of speed. Set to the base speed torque current limit.
- LMT\_TRQ\_INV: Torque reference regeneration absolute limit. The maximum regeneration torque reference allowed regardless of speed. Set to 2%.

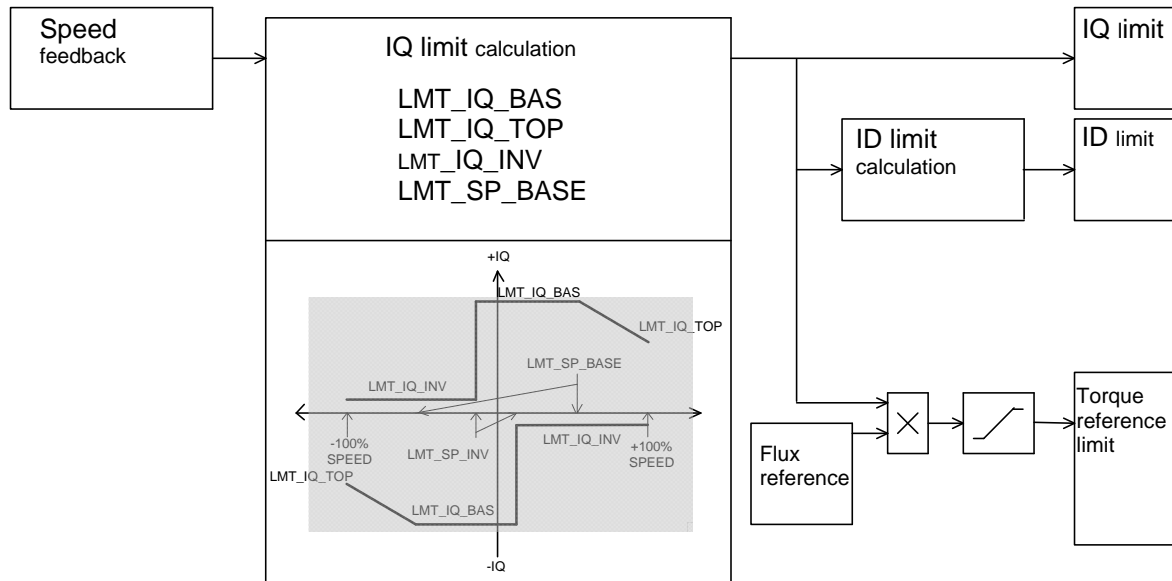

**IQ Limit**

**CIRCUIT OPERATION (cont'd)**

**Vector Control D-Q Axis Current Control**

The figure on the following page shows the block diagram of D-Q axis current control.

This system controls the current of an induction motor by separating it into a magnetic flux (Field) component and a torque component. This drive controls the current on the D-Q coordinates. It can control the current to an AC motor as a DC value, achieving high performance control irrespective of output frequencies.

**(1) ID (Field current) control**

A magnetic flux reference is generated based upon the speed reference. This and the field current setting (MI\_ID\_BASE) are used to generate an ID reference. This ID reference and the ID feedback signal are input into a PI controller. The output of this controller is the ED\_R (Field voltage reference). Optional Inductance (L) compensation can also be used (ACR\_WL). If used, this value is combined with the PI controller output to create the ED\_R.

**(2) IQ (Torque current) control**

The torque reference, which is the result of the previously mentioned speed control, is input and divided by magnetic flux to obtain an IQ reference. This IQ reference and IQ feedback signal are input into a PI controller. The output of this controller is the EQ\_R (Torque voltage reference). An induction voltage compensation (ACR\_E2) and L compensation (ACR\_WL) may also be used. If used these values are combined with the output of the PI controller to create the EQ\_R.

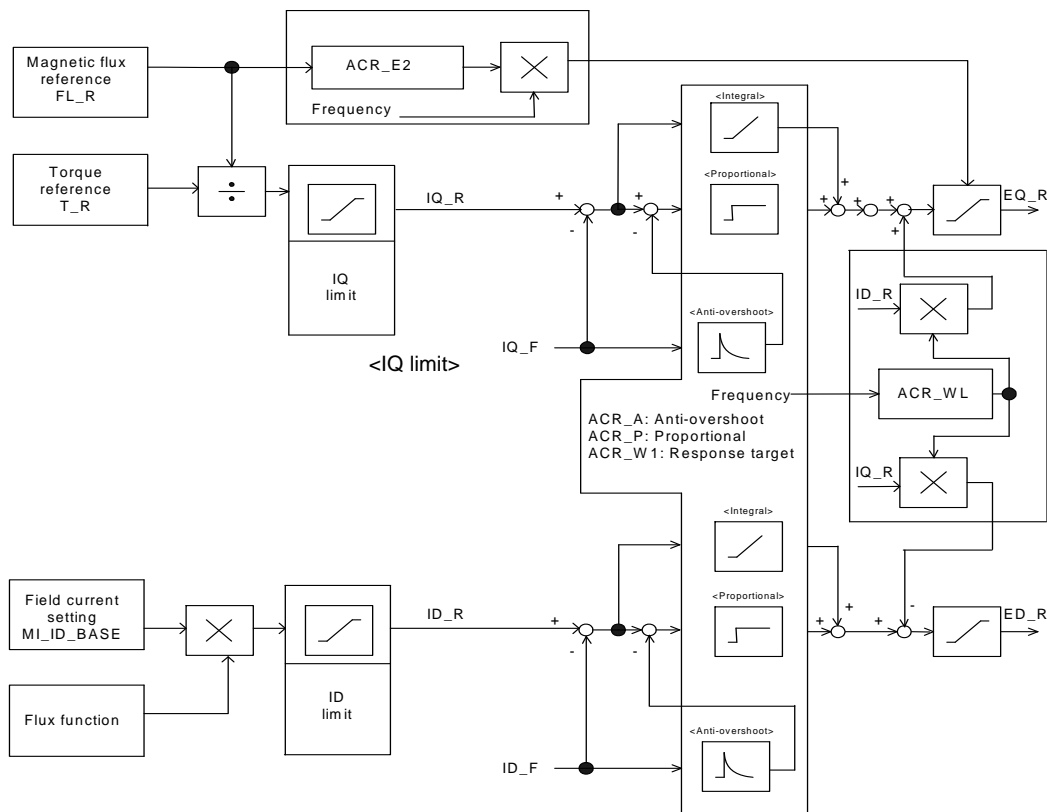

**D-Q Axis Current Control**

**CIRCUIT OPERATION (cont'd)**

**V/f Control**

(1) Frequency reference (F<sub>P</sub>)

The frequency reference is determined by the speed reference signal(SP<sub>R</sub>) and the slip frequency, when slip compensation is used. The frequency is compensated by the change of the Q axis current for the control stability.

(2) Q axis voltage reference (EQ<sub>R</sub>)

The Q axis voltage reference is proportional to the frequency reference and flux reference. This voltage may be compensated by the Q axis current for auto torque boost, when advanced V/f control is used. The V/f rate can be changed by the selected V/f pattern. The Q axis voltage is compensated by the change of the D axis current for the control stability.

(3) D axis voltage reference (ED<sub>R</sub>)

The D axis voltage reference is used for low speed torque boost normally. This voltage can also be compensated based upon Q axis current, when advance V/f control is used.

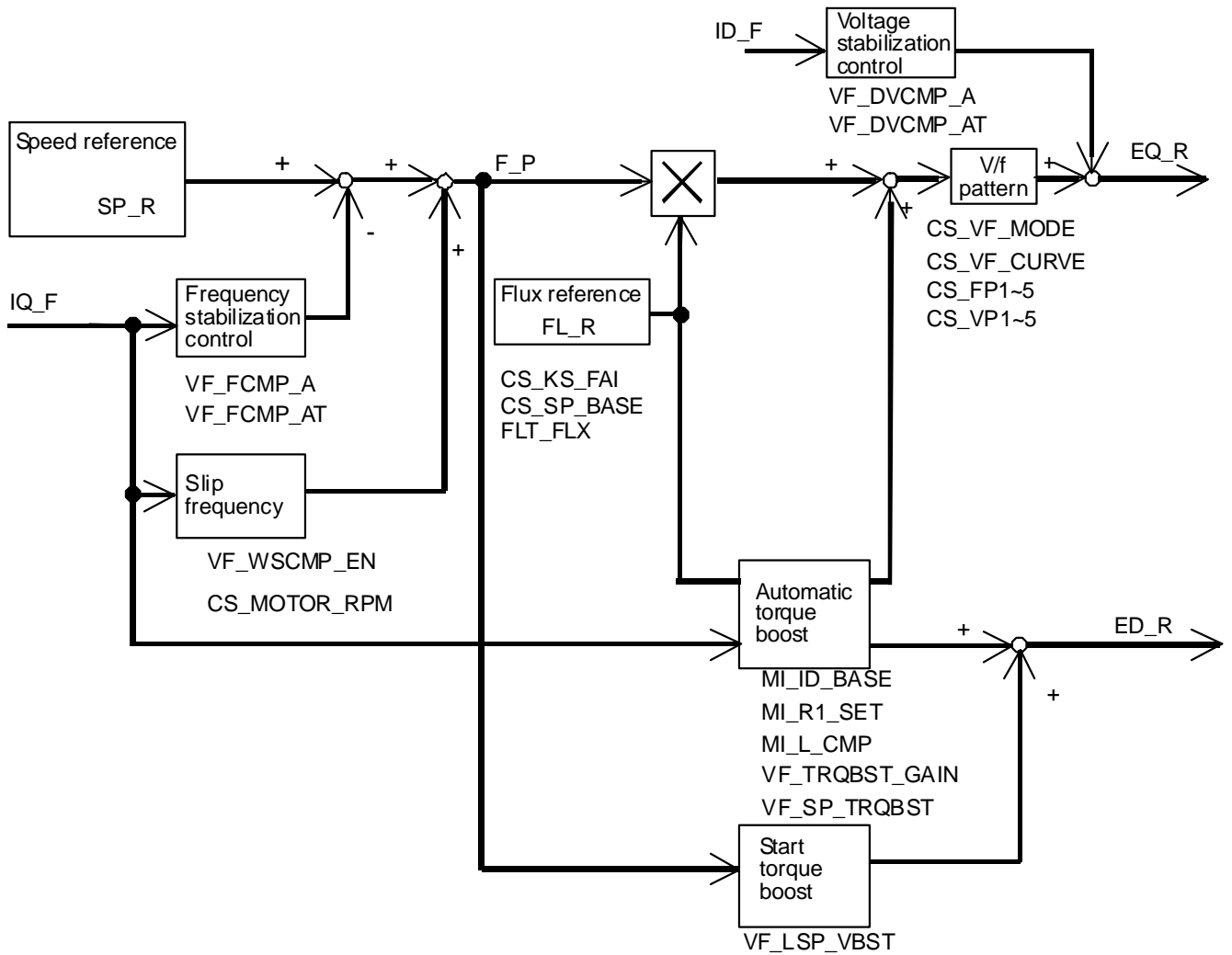

**CIRCUIT OPERATION (cont'd)**

**Control Circuit for SM (Synchronous Motor) control**

(1) Interface

SM control requires the use of an exciter. The exciter may be internal or external to the drive. The interface to the exciter is shown below.

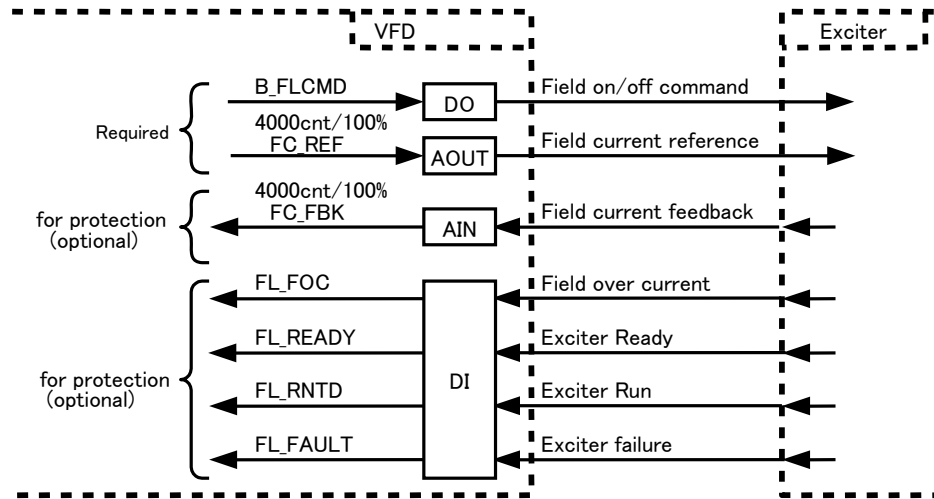

(2) Timing chart

There are 3 control modes.

Mode1 "Initial position detection" : Initial position is detected when motor is stopped.

Mode2 "Constant IQ starting": This mode starts the motor without speed control. It uses the initial position and current control with pre-set speed reference rate and current.

Mode3 "0PS control" (zero-PS): Speed and phase angle are estimated by the motor voltage PLL. Once the drive enters this mode it is in speed control and will follow the external speed reference.

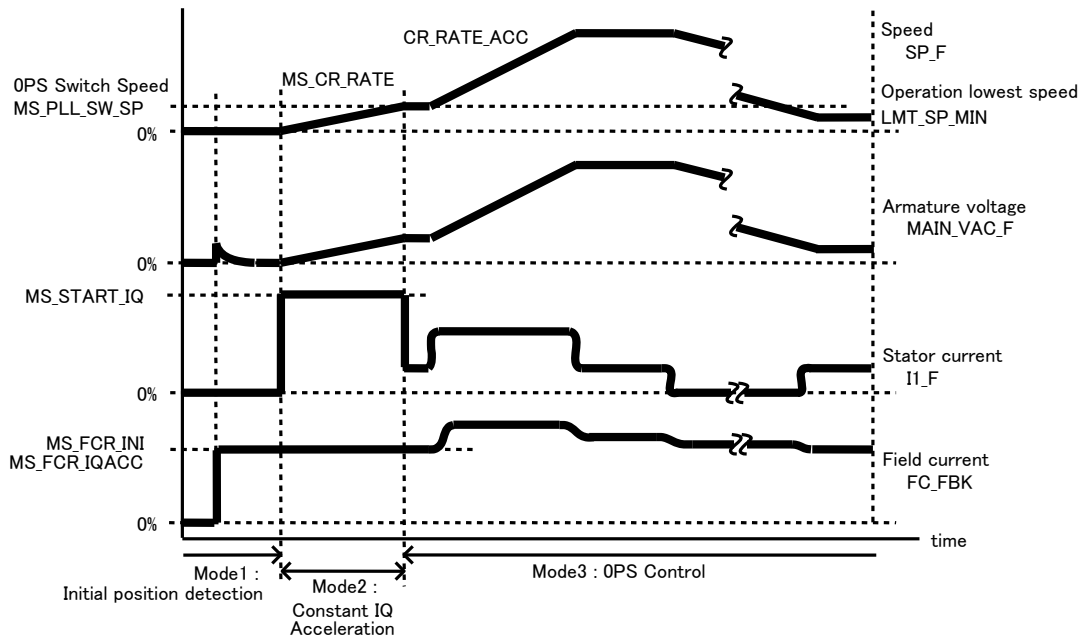

**CIRCUIT OPERATION (cont'd)**

**SM Control Block Diagram**

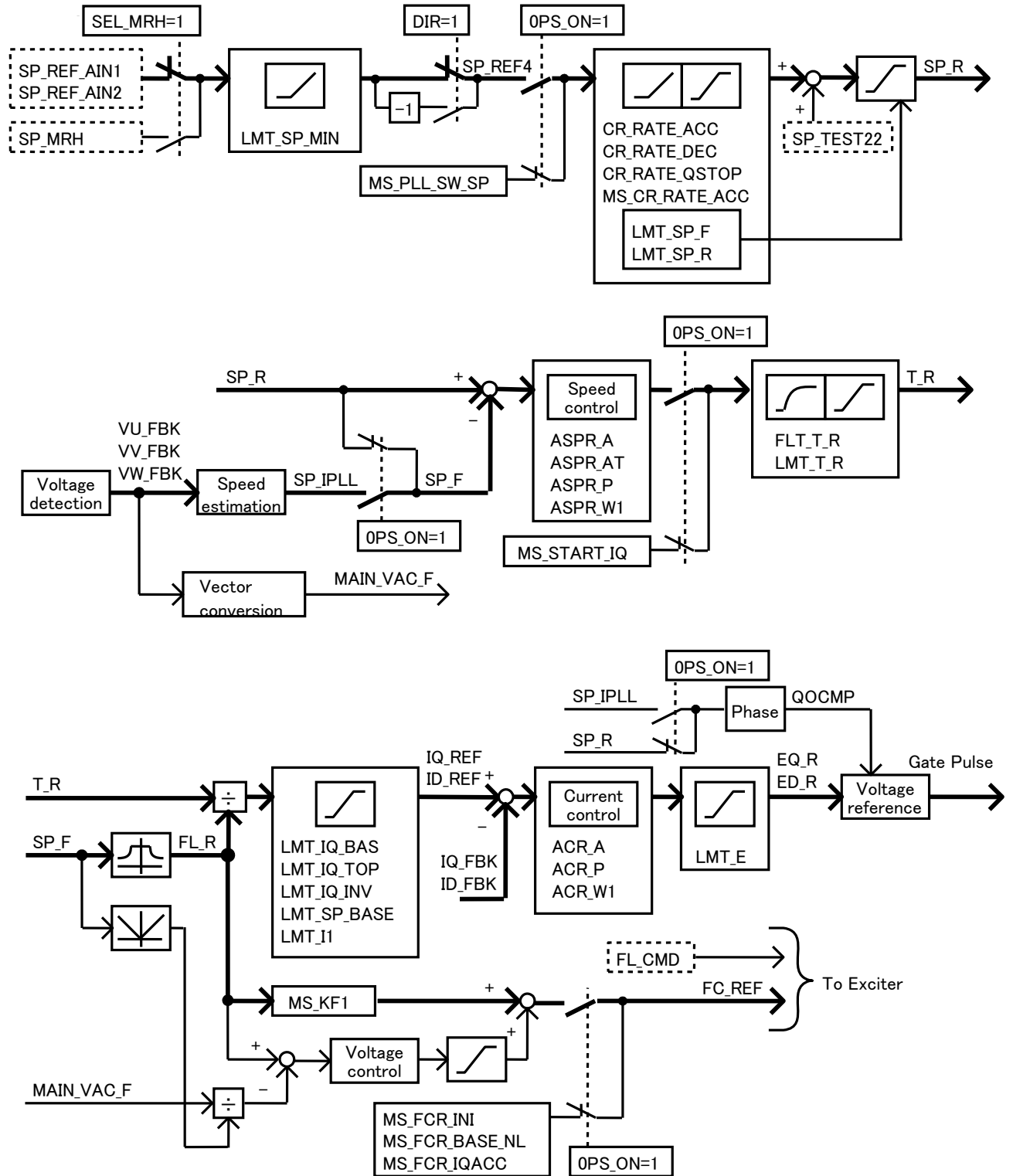

**CIRCUIT OPERATION (cont'd)**

**Speed Feedback (Option)**

As an option, a Resolver or a Pulse Generator (PG) can be selected for speed feedback. Speed control with a Tach Generator is not available because Tach Generator performance is poor.

**Resolver**

A resolver is an analog feedback device that used for speed feedback. Two sinewave excitation signals (sine and cosine) are sent to the resolver and two signals (sine and cosine) are returned to the drive. The use of these two phase shifted signals allows the direction rotation to be determined. The position of the motor rotor is determined by the phase difference between the excitation and return signals. The speed is found from the change in this position over time.

**PG**

A signal is detected from a single ended PG attached to the motor and converted to a speed. Detection is performed according to the pulse interval measurement system. This system converts a signal to a speed based on the fact that the interval (time) between pulses input is inversely proportional to the speed. The maximum input frequency is 10kHz.

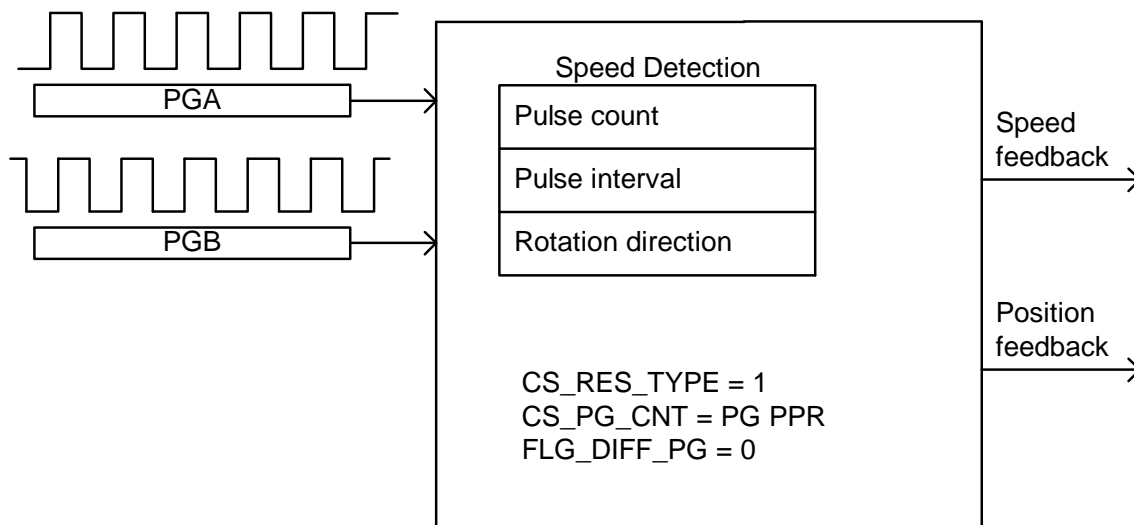

**PG Speed Detection**

**OPERATION**

The powering-on operation must follow a certain sequence. Failing to observe the powering-on sequence described here may cause unnecessary stress on the equipment. **Be sure to observe the powering-on sequence.**



**WARNING**



**While the equipment is in operation and the motor is running, do not turn off the main circuit power supply or control power supply under any circumstances. Do not open the cubicle doors or remove any covers.**

When the operation of the equipment is completely stopped, use the following basic procedure to turn on/off the power.

NOTE: On some drives, the control power supply is internally derived from the main circuit power supply. In this case, disregard the steps below involving the 480 Vac control power supply.

***General power-on and power-off sequence.***

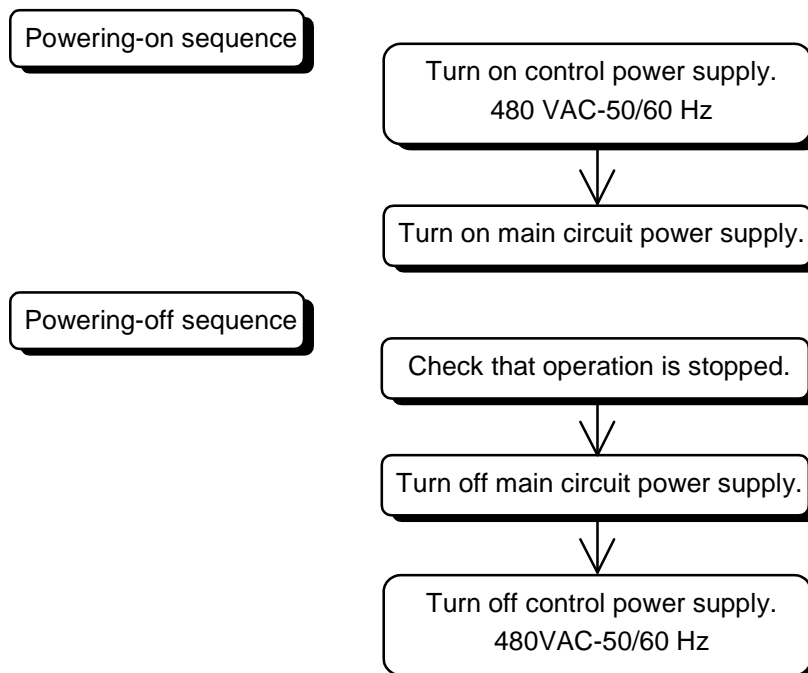

## OPERATION (cont'd)

### Pre-Operation Check Points

Check the following points before starting the operation.

- 1) Wiring is correct.
- 2) A voltage of 2400 V, or 4160 V,  $\pm 10\%$  can be supplied as the input power supply voltage.
- 3) A voltage of 480 VAC  $\pm 10\%$  can be supplied as the control power supply voltage.
- 4) The ground bus and any shielded wires are grounded.
- 5) The motor frame is also grounded.
- 6) The motor main circuit wire is not grounded.

### Powering-On

The power should be turned on when the motor is completely stopped.

- 1) Turn on the control power supply MCCB "CONTROL."
- 2) Interlock the drive with the interlock switch on the keypad.
- 3) Turn on the main power supply.
- 4) Release the interlock switch on the keypad.

### Operation

This section shows a typical operation procedure. You are also required to observe your own safety rules to prevent accidents.

### Normal Operation

When carrying out a normal operation using the digital interface (refer to the keypad manual for keypad operation), check that the necessary interface signals are correctly connected and then follow the procedure below.

- 1) Set the frequency command signal.
- 2) Turn on the IL (interlock) input signal if used.
- 3) Turn on the UVS input.
- 4) Turn on the EXT (start command) input signal.
- 5) Vary the frequency command as needed. Do not run the drive at zero speed unless you have a speed sensor.
- 6) Turning off the EXT signal during operation ramps the motor to a stop.
- 7) Removing the UVS signal or the IL signal during operation turns off the output of the drive and the motor coasts to a stop. If these signals are removed during operation, the EXT command must be removed and the UVS and/IL restored before the drive will restart.

### Powering-Off

- 1) Stop the motor by removing the EXT, the IL, or the UVS command.
- 2) After the motor has stopped, interlock the drive with the interlock button on the keypad.
- 3) Turn off the external main power supply.
- 4) Turn off the control power supply MCCB "CONTROL."

## DATA CONTROL

### Setting Data

The parameter setfile is stored in the EEPROM on the main control board. This is non-volatile memory and will not generally be lost when the drive is powered down. However, this data could be lost if there is a board failure. If this data is lost, the drive will need to be re-commissioned. For this reason, it is recommended that the parameter setfile data be backed up in a file stored on a personal computer. This requires the use of the optional commissioning software. The software and training is available through Toshiba.

## FAULT AND RECOVERY

### Cautions when Handling Fault



## CAUTION

When a fault occurs, before resetting, understand the fault code. It may be unsafe to restart if a component or motor has failed. Every effort should be made to determine the cause of the fault and to correct any problems before attempting to restart the drive.

To do this, it is necessary to record and evaluate the phenomena and conditions of the fault in detail from both electrical and mechanical standpoints. Collect as much data as possible on the following items to determine the operation situation when the fault occurred.

- 1) Record the fault message (fault display) shown on the display/keypad at the moment the fault occurred.
- 2) Collection of trace back data. Record the trace back data by PC(option).
- 3) Operation different from ordinary operation  
Check if there was anything that affected the input power supply of the equipment at the moment the fault occurred (for example, powering-on of large-capacity equipment which is connected to the common AC power supply or short-circuits, etc.).
- 4) Power failure  
Check if the input power supply of the equipment was disconnected at the time of the fault (for example, if the line of the AC power supply was switched or if the breaker was turned on or off).
- 5) Load condition  
Check if the load was drastically changed at the time of the fault.
- 6) Operation  
Check to see if any changes in the process or load machinery were made by the operator at the time of the fault.
- 7) Installation environment  
Check if there was any abnormal ambient conditions present in the electrical room at the time of the fault or before the fault. (Fault of air-conditioner or ventilation system, water leakage into the room, intrusion of dirt or chemicals, etc...)
- 8) Changes  
Check if there were any recent changes to other equipment around the drive or load machinery. For example, if some electrical work was carried out on or around the equipment.
- 9) Lightning  
Check if there were any lightning strikes in the area.
- 10) Abnormal sound, odor  
Check if there was any odor or abnormal sound around the equipment at the time of the fault or after.

Understanding the conditions before and during the fault can help to determine whether the fault is attributable to factors inside or outside of the drive. Further, this information becomes an important clue to determine the cause of intermittent faults. It is important to keep a precise record.

## Repair



## CAUTION

### Cautions on Repair

- **Be sure to use only the renewal parts specified by Toshiba. Parts other than those specified by Toshiba may not only not demonstrate the stipulated performance but also affect the safety. If spare parts are not available, contact Toshiba to order them or ask for replacement of parts.**
  - **This equipment includes parts that need to be replaced periodically. It takes time to deliver parts, so order them as early as possible.**
- 1) The power modules have been designed for easy replacement as a unit. They are sold as units and should be replaced as units. Individual parts should not be removed from or installed on the power module assemblies. Modules that have failed or are believed to have failed should be returned to the factory for evaluation, repair, and testing. Refer to the information label on the inside of the power module compartment door for instructions on replacing a power module.
  - 2) Prepare necessary tools and drawings, etc. before starting the work.
  - 3) Be careful not to damage other parts when removing some parts.
  - 4) Do not make wrong connections when changing parts. Put markings, etc., if necessary.
  - 5) Before restarting after changing any part verify all connections are correct.
  - 6) Use the right tools (torque wrench, etc.) when handling screws and bolts.
  - 7) Special care is required when handling heavy articles.
  - 8) When the work is completed, make sure that no tools or other foreign material is left in the drive.

**DRIVE INSTALLATION DRAWINGS**

**Frame 0 4160V module lifting and installation**

**WARNINGS**  
Disconnect power and wait 15 minutes to ensure capacitors are discharged before performing inspection or maintenance.

Improper handling of the fiber optic cables and connectors may cause drive failure due to problems transmitting signals. Take care not to disturb fiber optic cables when handling power module.

Use module lifting attachment GC16720G055 and a lifting device rated 250 lbs minimum for removal and installation of modules.

**Power Module Removal**

1. Disconnect and remove AC neutral bus.
2. Disconnect power cables ACL, P, C & N.
3. Remove control wiring cover (two "A" bolts)
4. Disconnect control signal cable and 120VAC supply cable from module.
5. Free slide tray by removing bolt "B".
6. Pull slide tray out until slides lock.
7. Remove four "C" bolts which secure module to tray.

**Power Module Removal (cont'd)**

8. Using module lifting attachment and lifter, lift module from tray.

**Power Module Installation**

1. Pull slide tray out until slides lock.
2. Using module lifting attachment and lifter, place module on tray.
3. Secure module to tray with four "C" bolts.
4. Press slide release buttons and slide module into compartment (use caution).
5. Reinstall bolt "B" to secure tray in position.
6. Reconnect control signal cable and 120VAC supply cable to module connectors.
7. Reinstall control wiring cover and secure with two "A" bolts.
8. Reconnect power cables ACL, P, C & N.
9. Reinstall AC neutral bus.
10. Torque all power connections (5/16-18 hdwr) to 10-15 ft-lbs.

PC94060P086

**Frame 1 4160V drive lifting and assembly**

! DANGER

TOP HEAVY EQUIPMENT

Cabinet Can Tip Over Causing Serious Injury or Death.

Do Not Attempt to Withdraw Power Modules Without First Securely Anchoring Equipment to Floor.

PC94060P007

DANGER

**When the service drawer is withdrawn, the power modules have sufficient weight to tip over the Frame 1 inverter cabinet if it is not firmly anchored to the mounting floor, resulting in severe injury or death.**

**DO NOT attempt to install or withdraw the Frame 1 power modules before first securely anchoring the cabinet to the floor.**

**DRIVE INSTALLATION DRAWINGS (cont'd)**

**Frame 1 drive lifting and assembly (cont'd)**

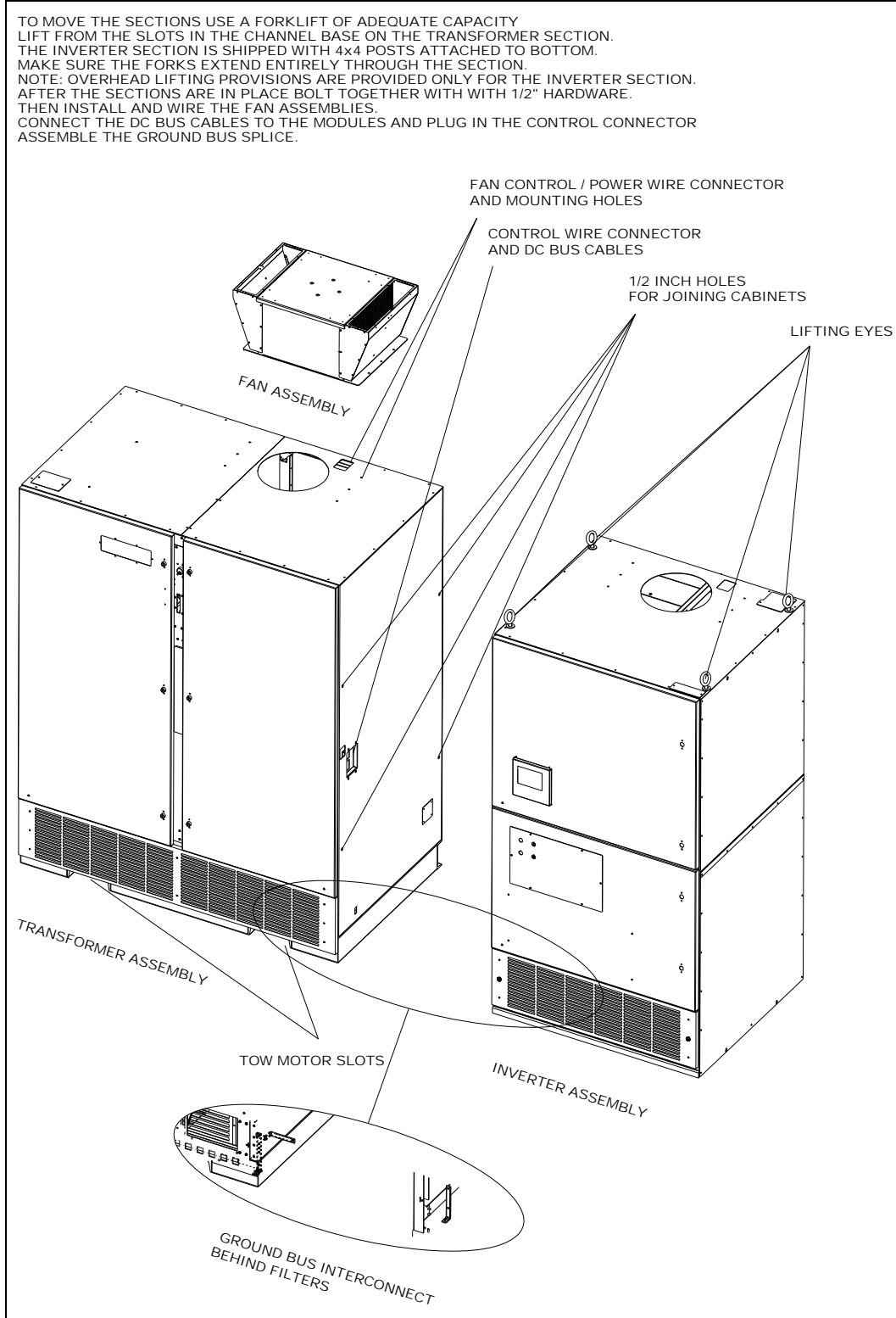

## DRIVE INSTALLATION DRAWINGS (cont'd)

### Frame 1 2400V module lifting and installation

**WARNINGS**  
Inverter cabinet is top heavy. Cabinet must be anchored to floor before withdrawing power modules to prevent tipping.

Disconnect power and wait 15 minutes to ensure capacitors are discharged before performing inspection or maintenance.

Improper handling of the fiber optic cables and connectors may cause drive failure due to problems transmitting signals. Take care not to disturb fiber optic cables when handling power module.

Use module lifting attachment GC16721G055 and a lifting device rated 350 lbs minimum for removal and installation of modules.

**Power Module Removal**

1. Disconnect power cables ACL, P, C & N (P, C & N on right-hand module only).
2. Disconnect and remove bus bars P, C & N.
3. Remove control wiring cover (two "A" bolts)
4. Disconnect control signal cable and 120VAC supply cable from module.
5. Free slide tray by removing bolt "B".

**Power Module Removal (cont'd)**

6. Pull slide tray out until slides lock.
7. Remove four "C" bolts which secure module to tray.
8. Using module lifting attachment and lifter, lift module from tray.

**Power Module Installation**

1. Pull slide tray out until slides lock.
2. Using module lifting attachment and lifter, place module on tray.
3. Secure module to tray with four "C" bolts.
4. Press slide release buttons and slide module into compartment (use caution).
5. Reinstall bolt "B" to secure tray in position.
6. Reconnect control signal cable and 120VAC supply cable to module connectors.
7. Reinstall control wiring cover and secure with two "A" bolts.
8. Reinstall bus bars P, C & N.
9. Reconnect power cables ACL, P, C & N (P, C & N on right-hand module only).
10. Torque all power connections (5/16-18 hdwr) to 10-15 ft-lbs.

### Frame 1 4160V module lifting and installation

**WARNINGS**  
Inverter cabinet is top heavy. Cabinet must be anchored to floor before withdrawing power modules to prevent tipping.

Disconnect power and wait 15 minutes to ensure capacitors are discharged before performing inspection or maintenance.

Improper handling of the fiber optic cables and connectors may cause drive failure due to problems transmitting signals. Take care not to disturb fiber optic cables when handling power module.

Use module lifting attachment GC16721G055 and a lifting device rated 350 lbs minimum for removal and installation of modules.

**Power Module Removal**

1. Disconnect and remove AC neutral bus.
2. Disconnect power cables ACL, P, C & N.
3. Remove control wiring cover (two "A" bolts)
4. Disconnect control signal cable and 120VAC supply cable from module.
5. Free slide tray by removing bolt "B".

**Power Module Removal (cont'd)**

6. Pull slide tray out until slides lock.
7. Remove four "C" bolts which secure module to tray.
8. Using module lifting attachment and lifter, lift module from tray.

**Power Module Installation**

1. Pull slide tray out until slides lock.
2. Using module lifting attachment and lifter, place module on tray.
3. Secure module to tray with four "C" bolts.
4. Press slide release buttons and slide module into compartment (use caution).
5. Reinstall bolt "B" to secure tray in position.
6. Reconnect control signal cable and 120VAC supply cable to module connectors.
7. Reinstall control wiring cover and secure with two "A" bolts.
8. Reconnect power cables ACL, P, C & N.
9. Reinstall AC neutral bus.
10. Torque all power connections (5/16-18 hdwr) to 10-15 ft-lbs.

**DRIVE INSTALLATION DRAWINGS (cont'd)**

**Frame 2 drive lifting and assembly**

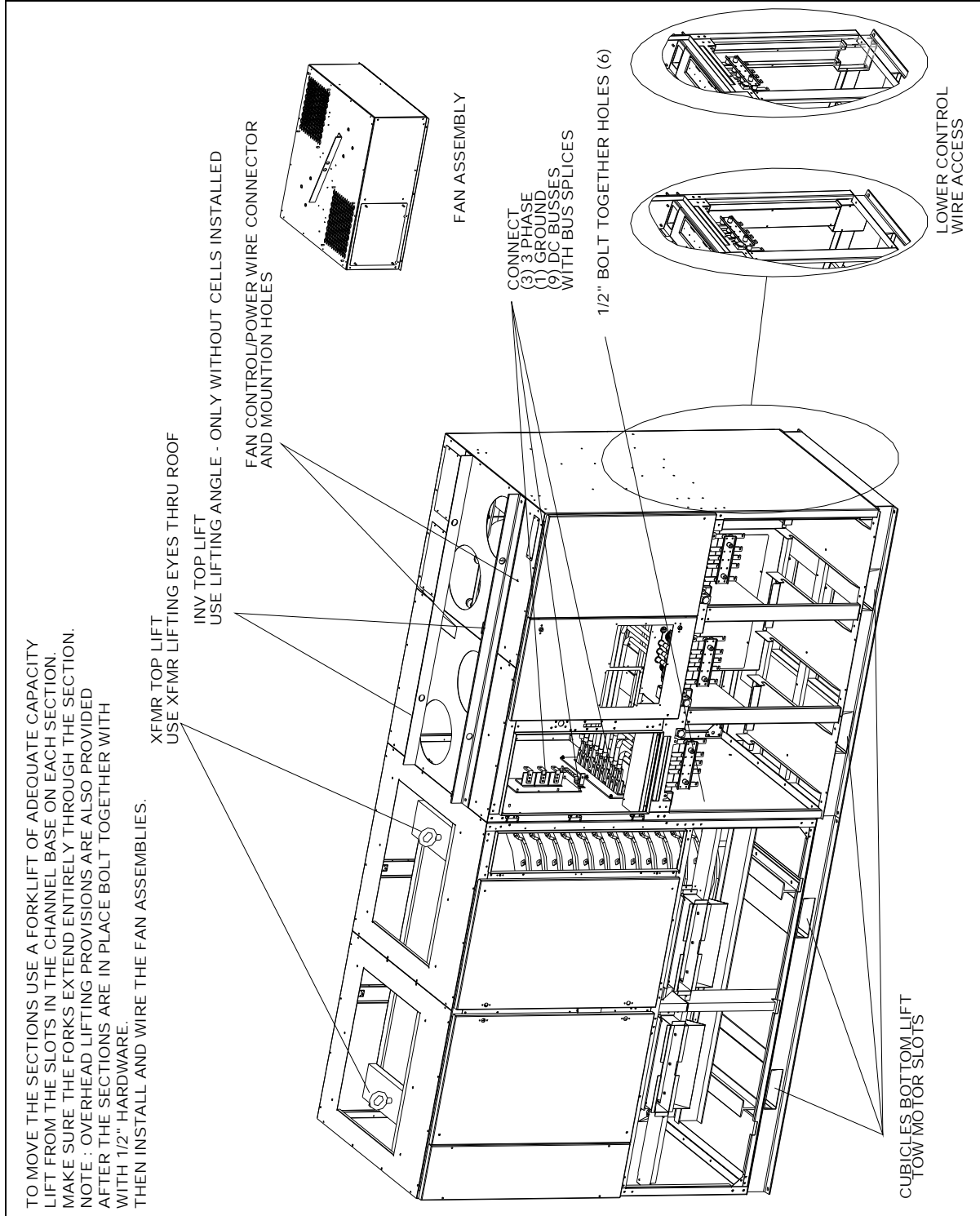

**DRIVE INSTALLATION DRAWINGS (cont'd)**

**Frame 2 drive main cable installation**

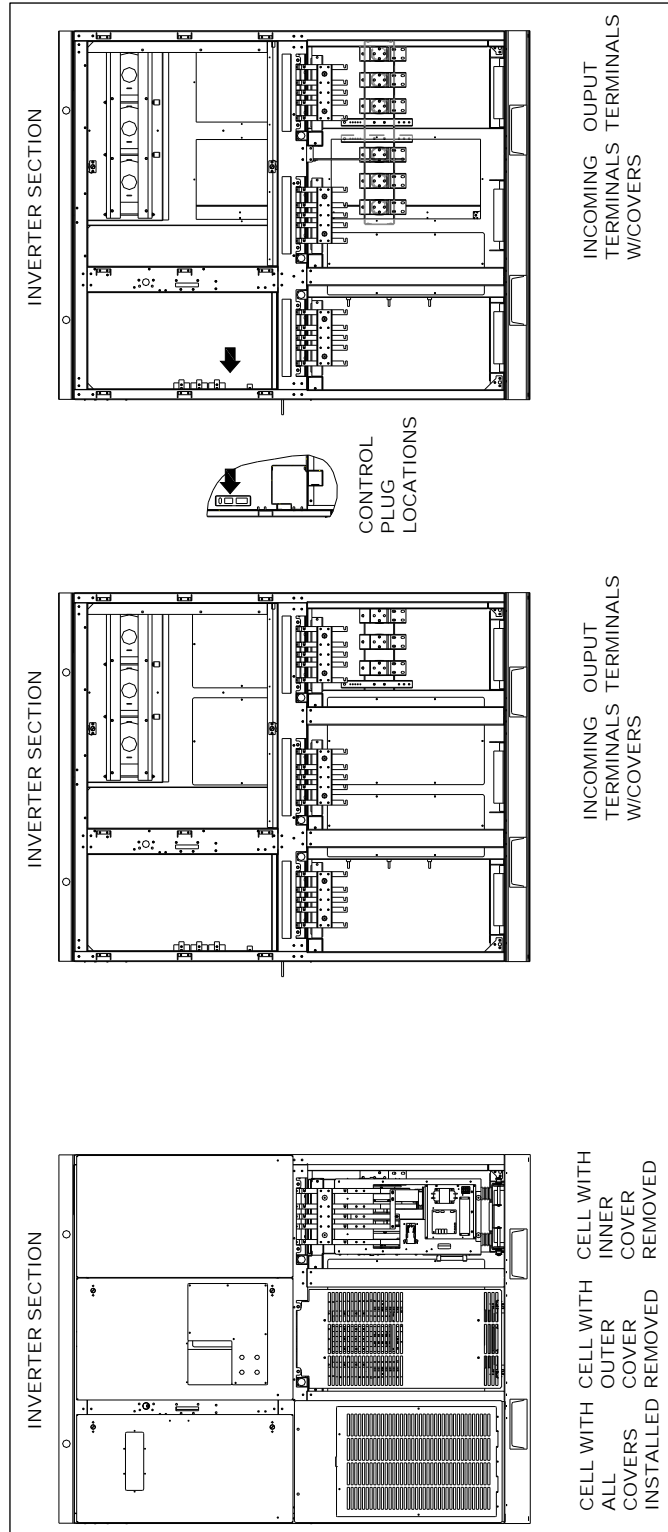

**DRIVE INSTALLATION DRAWINGS (cont'd)**

**Frame 2 module lifting**

**LIFTING PROVISIONS**  
2 LIFTING PROVISIONS ARE AVAILABLE

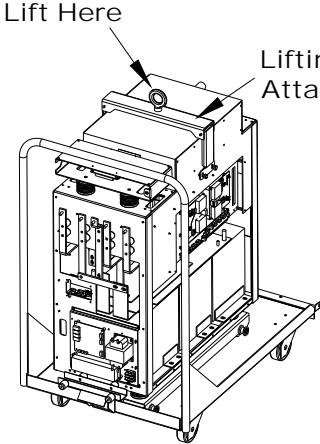

1. Load or remove power module from truck GCI6723G055 using lifting attachment GCI6722G055 and a lifting device rated for 750 lbs or more.

Secure lifting attachment to power module using (4) 3/8-16 bolts provided.

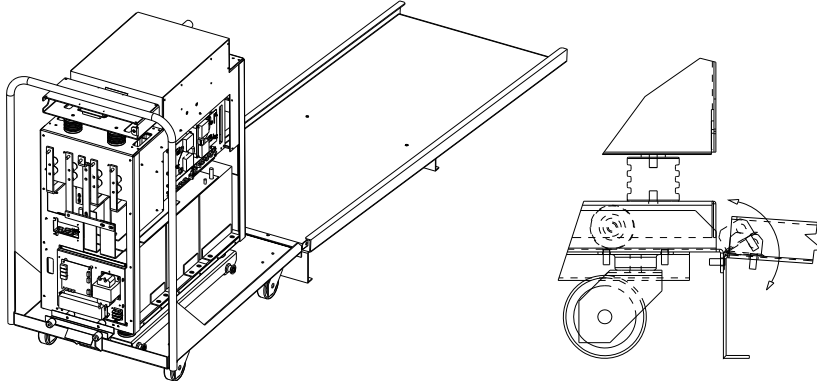

2. Load or remove power module from truck GCI6723G055 using ramp assembly GCI6723G053.

Lock truck to ramp by inserting truck pins into ramp holes.

Set brakes on truck before carefully rolling power module up or down ramp.

PC94060P098

## DRIVE INSTALLATION DRAWINGS (cont'd)

### Frame 2 4160V module installation

<p>Control Wiring Cover</p> <p>Control Signal Cable &amp; 120VAC Supply Cable</p> <p>Bus Link Assembly</p> <p>Front Barrier</p> <p><b>POWER MODULE DISCONNECTION</b></p>	<p>Engage Latch</p> <p>Set Wheel Brakes</p> <p>Power Module Truck GCI6723G055</p> <p>Secure Truck to Cubicle</p> <p><b>POWER MODULE REMOVAL</b></p>		
<p><b>WARNINGS</b> Disconnect power and wait 15 minutes to ensure capacitors are discharged before performing inspection or maintenance.</p> <p>Improper handling of the fiber optic cables and connectors may cause drive failure due to problems transmitting signals. Take care not to disturb fiber optic cables when handling power module.</p>	<p><b>Power Module Disconnection</b></p> <ol style="list-style-type: none"> <li>1. Remove front barrier (four bolts).</li> <li>2. Loosen ten nuts and remove bus link assembly by sliding sideways and off.</li> <li>3. Remove control wiring cover (two bolts)</li> <li>4. Disconnect control signal cable and 120VAC supply cable from module.</li> </ol>	<p><b>Power Module Removal</b></p> <ol style="list-style-type: none"> <li>1. Align truck GCI6723G055 with front of cubicle.</li> <li>2. Secure truck to cubicle by inserting two studs into holes in base.</li> <li>3. Set wheel brakes on truck.</li> <li>4. Roll power module onto truck until front latch engages.</li> <li>5. Refer to additional instruction label for moving power module on and off of truck.</li> </ol>	<p><b>Power Module Reinstallation</b></p> <ol style="list-style-type: none"> <li>1. Reverse the procedure followed during disconnection and removal of power module.</li> <li>2. Ensure that control signal cable and 120VAC supply cable are properly reconnected.</li> <li>3. Reinstall all hardware previously removed.</li> <li>4. Torque bus link connections (5/16-18 hdwr) to 10-15 ft-lbs.</li> </ol> <p style="text-align: right;">PC94060P097</p>

**DRIVE INSTALLATION DRAWINGS (cont'd)**

**Frame 3 drive lifting and assembly**

TO MOVE THE SECTIONS USE A FORKLIFT OF ADEQUATE CAPACITY LIFT FROM THE SLOTS IN THE CHANNEL BASE ON EACH SECTION. MAKE SURE THE FORKS EXTEND ENTIRELY THROUGH THE SECTION. NOTE OVERHEAD LIFTING PROVISIONS ARE ALSO PROVIDED AFTER THE SECTIONS ARE IN PLACE, BOLT TOGETHER WITH WITH 1/2" HARDWARE. INSTALL THE MAIN AND DC BUS LINKS AND THE CONTROL CONNECTOR THEN INSTALL AND WIRE THE FAN ASSEMBLIES.

FOR LIFTING THE SECTION USE THE TRANSFORMER LIFTING EYES.

CONTROL CONNECTOR  
 MAIN AND DC BUS LINKS

1/2" BOLT TOGETHER HOLES (6)  
 FOR LIFTING USE THE LIFTING ANGLES  
 (WITH CELLS REMOVED)

FAN CONTROL/POWER WIRE CONNECTOR  
 AND MOUNTING HOLES

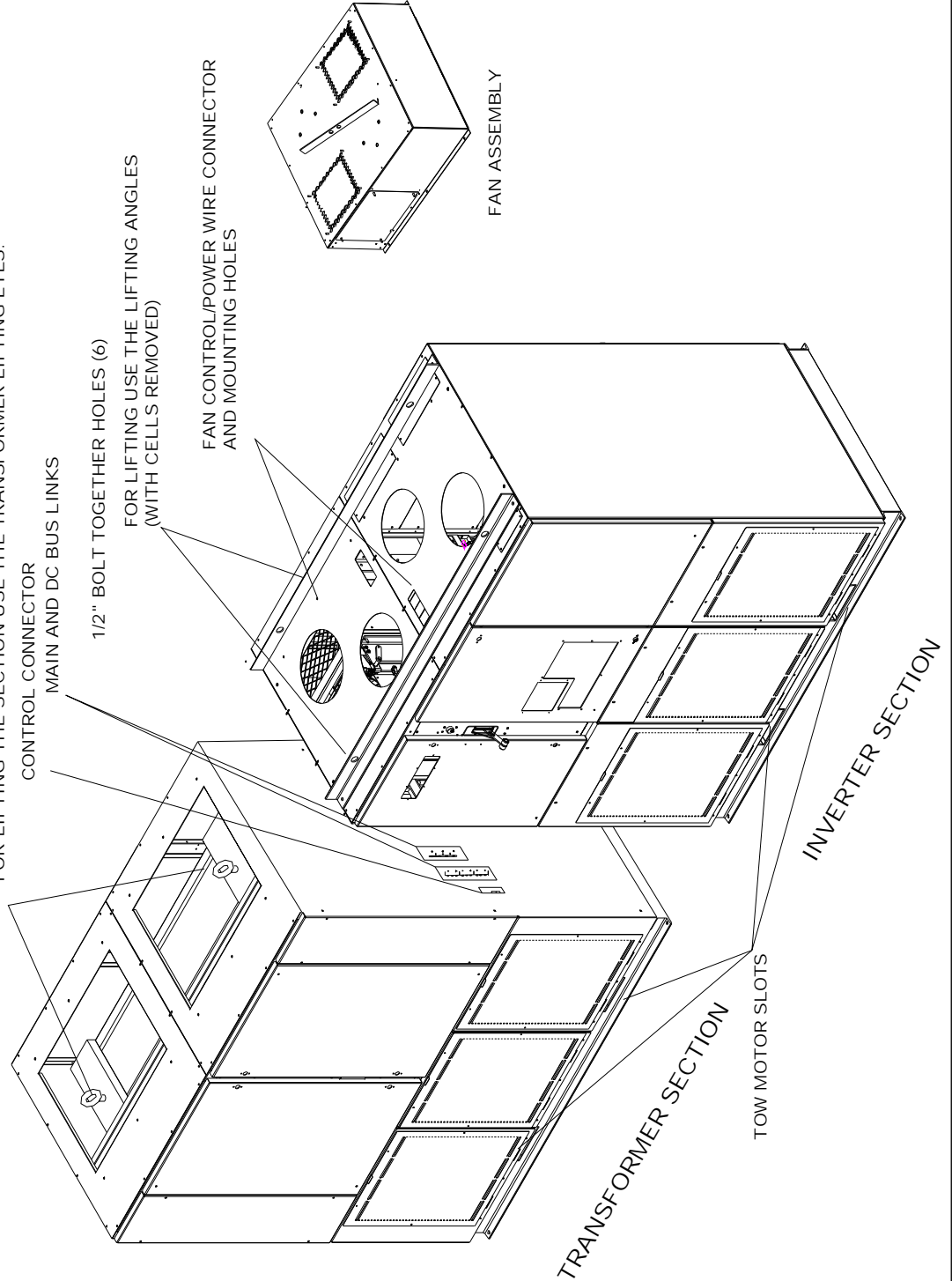

**DRIVE INSTALLATION DRAWINGS (cont'd)**

**Frame 3 drive main cable installation**

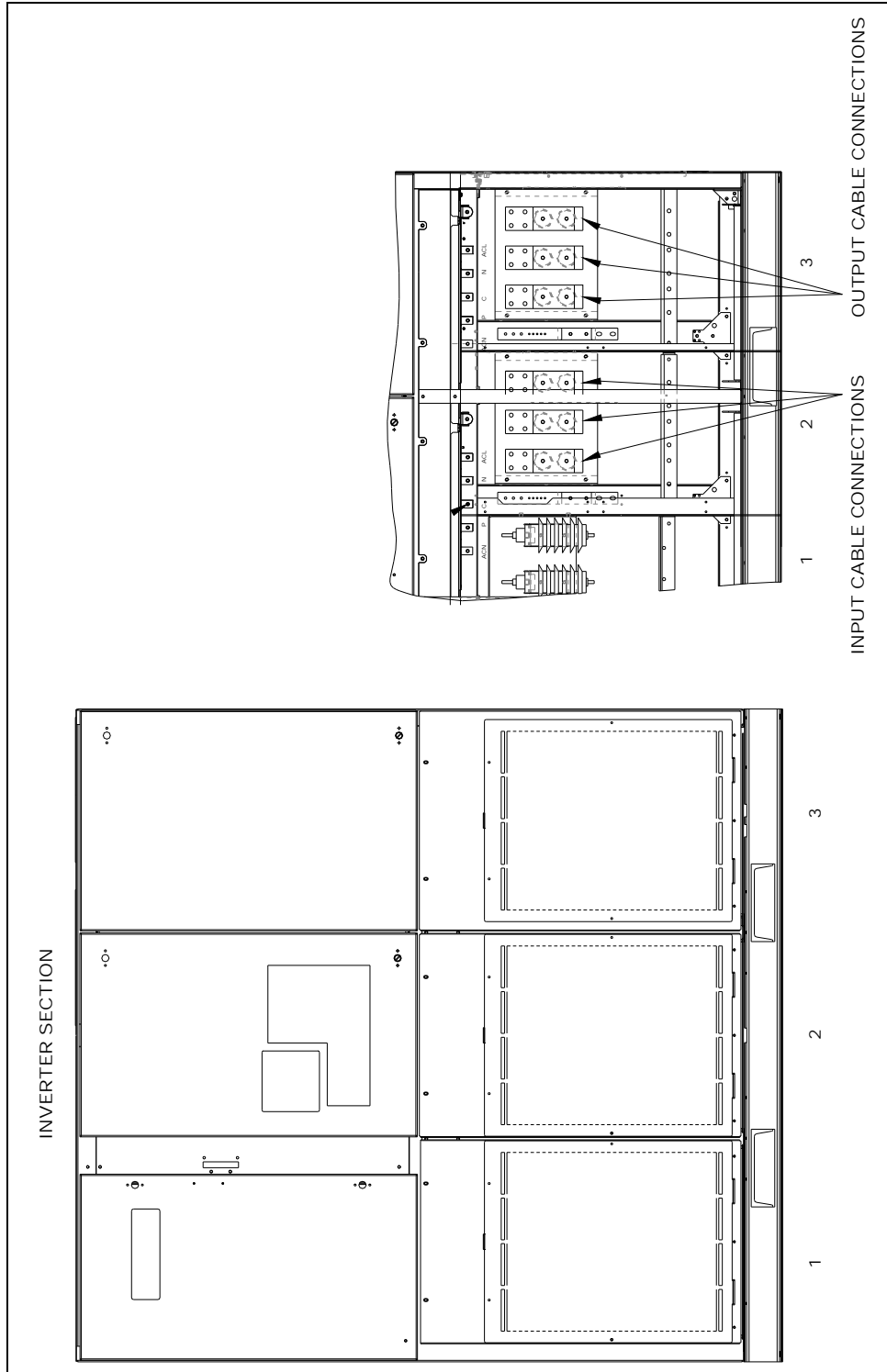

**DRIVE INSTALLATION DRAWINGS (cont'd)**

**Frame 3 module lifting**

**LIFTING PROVISIONS**

LIFT HERE      2 LIFTING PROVISIONS ARE AVAILABLE

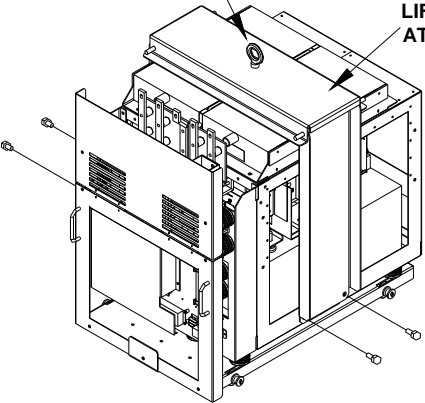

LIFTING ATTACHMENT

**1. LOAD OR REMOVE POWER MODULE FROM TRUCK GCI6723G055 USING LIFTING ATTACHMENT GCI6723G054 AND A LIFTING DEVICE RATED FOR 1000 LBS. OR MORE.**

**SECURE BRACKET TO POWER MODULE USING (4) 1/2-13 BOLTS.**

---

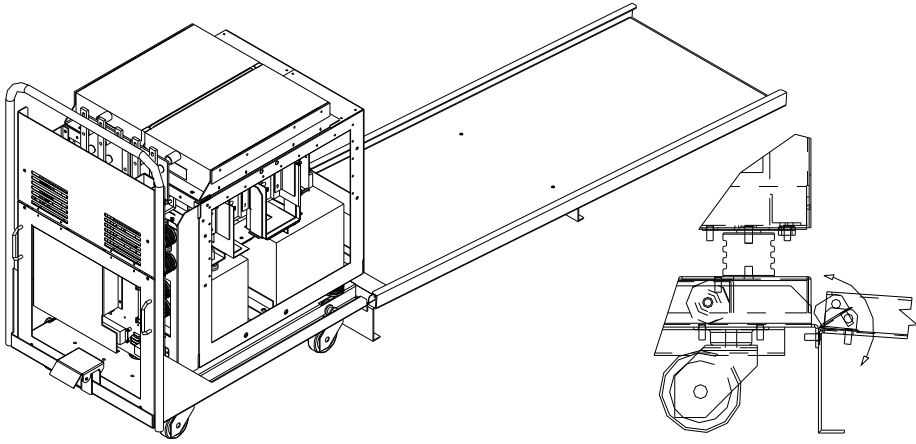

**2. LOAD OR REMOVE POWER MODULE FROM TRUCK USING RAMP ASSEMBLY GCI6723G053.**

**LOCK TRUCK TO RAMP BY INSERTING TRUCK PINS INTO RAMP HOLES.**

**SET BRAKE ON TRUCK BEFORE CAREFULLY ROLLING POWER MODULE UP OR DOWN RAMP**

**PC94060P093**

## DRIVE INSTALLATION DRAWINGS (cont'd)

### Frame 3 2400V module installation

<p><b>WARNINGS</b></p> <p>Disconnect power and wait 15 minutes to ensure capacitors are discharged before performing inspection or maintenance.</p> <p>Improper handling of the fiber optic cables and connectors may cause drive failure due to problems transmitting signals. Take care not to disturb fiber optic cables when handling power module.</p> <p>Use Truck GC16723G055 for removal &amp; installation of modules.</p>	
<p><b>Power Module Removal</b></p> <ol style="list-style-type: none"> <li>1. After capacitor discharge, open upper Power Module cover.</li> <li>2. Disconnect Control Cable from PCB 'A' and lay in wireway above Power Module.</li> <li>3. Disconnect Control Power Cable 'B', lay in wireway above Power Module.</li> <li>4. Remove (4) bolts 'C' from bus stabs P, C, N &amp; ACL</li> <li>5. Remove (1) bolt 'D' from back of Power Module cableway.</li> <li>6. Lock Truck GC16723G055 to enclosure, insert truck pins into holes in front edge of lower pan 'E'. Set truck brake.</li> <li>7. Withdraw Power Module by handles onto truck until latch engages 'F'. Unlock truck.</li> </ol>	<p><b>Power Module Installation</b></p> <ol style="list-style-type: none"> <li>1. Load Power Module onto Truck. Engage truck latch 'F'.</li> <li>2. Lock Truck GC16723G055 to front of enclosure, inserting truck pins into holes in front edge of lower pan 'E'.</li> <li>3. Unlatch Power Module 'F'. Roll Power Module by handles from truck onto enclosure rail until enclosure and Power Module bus stabs touch.</li> <li>4. Install (1) bolt 'D' at back of cableway. Unlock, remove truck.</li> <li>5. Install (4) bolts 'C' through bus stabs P, C, N &amp; ACL. Torque all power connections (5/16-18 hdwr) to 10-15 ft-lbs.</li> <li>6. Connect Control Power Cable from wireway as shown at 'B'.</li> <li>7. Connect Control Cable from wireway to PCB as shown at 'A'.</li> <li>8. Close upper Power Module cover. Secure with 2 bolts.</li> <li>9. Replace outside filter cover.</li> </ol> <p style="text-align: right;">PC94060P100</p>

## DRIVE INSTALLATION DRAWINGS (cont'd)

### Frame 3 4160V module installation

#### WARNINGS

Disconnect power and wait 15 minutes to ensure capacitors are discharged before performing inspection or maintenance.

Improper handling of the fiber optic cables and connectors may cause drive failure due to problems transmitting signals.

Take care not to disturb fiber optic cables when handling power module.

Use Truck GCI6723G055 for removal & installation of modules.

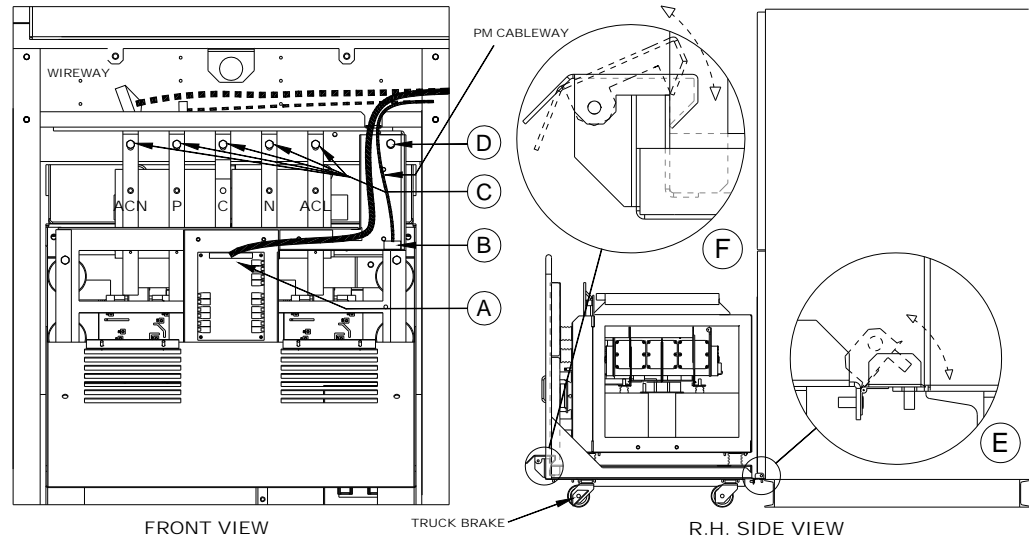

#### Power Module Removal

1. After capacitor discharge, open upper Power Module cover.
2. Disconnect Control Cable from PCB 'A' and lay in wireway above Power Module.
3. Disconnect Control Power Cable 'B', lay in wireway above Power Module.
4. Remove (5) bolts 'C' from bus stabs ACN, P, C, N & ACL.
5. Remove (1) bolt 'D' from back of Power Module cableway.
6. Lock Truck GCI6723G055 to enclosure, insert truck pins into holes in front edge of lower pan 'E'. Set truck brake.
7. Withdraw Power Module by handles onto truck until latch engages 'F'. Unlock truck.

#### Power Module Installation

1. Load Power Module onto Truck. Engage truck latch 'F'.
2. Lock Truck GCI6723G055 to front of enclosure, inserting truck pins into holes in front edge of lower pan 'E'.
3. Unlatch Power Module 'F'. Roll Power Module by handles from truck onto enclosure rail until enclosure and Power Module bus stabs touch.
4. Install (1) bolt 'D' at back of cableway. Unlock, remove truck.
5. Install (5) bolts 'C' through bus stabs ACN, P, C, N & ACL. Torque all power connections (5/16-18 hdwr) to 10-15 ft-lbs.
6. Connect Control Power Cable from wireway as shown at 'B'.
7. Connect Control Cable from wireway to PCB as shown at 'A'.
8. Close upper Power Module cover. Secure with 2 bolts.
9. Replace outside filter cover.

PC94060P092

**DRIVE INSTALLATION DRAWINGS (cont'd)**

**Frame 4 drive lifting and assembly**

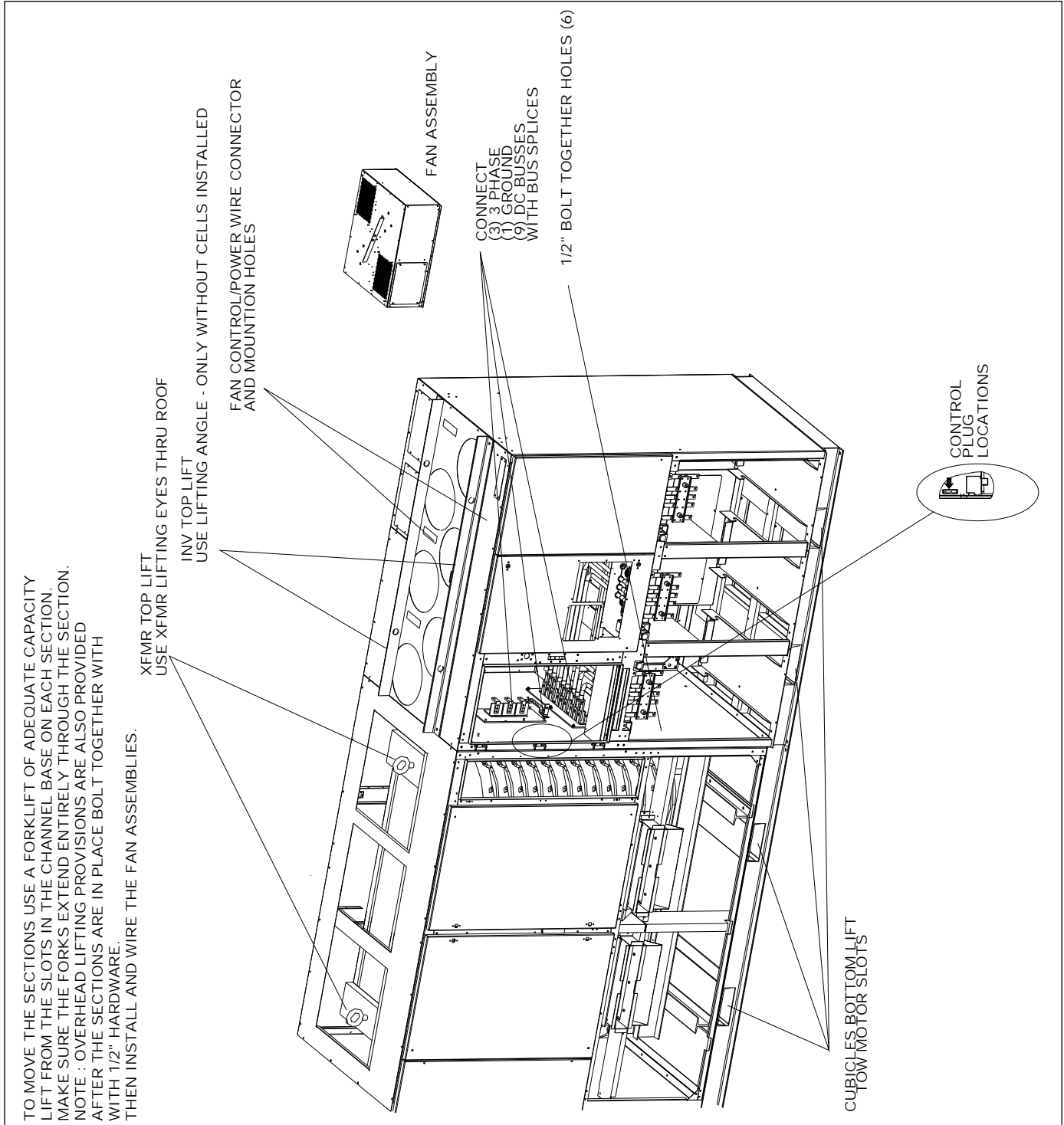

**DRIVE INSTALLATION DRAWINGS (cont'd)**

**Frame 4 drive main cable installation**

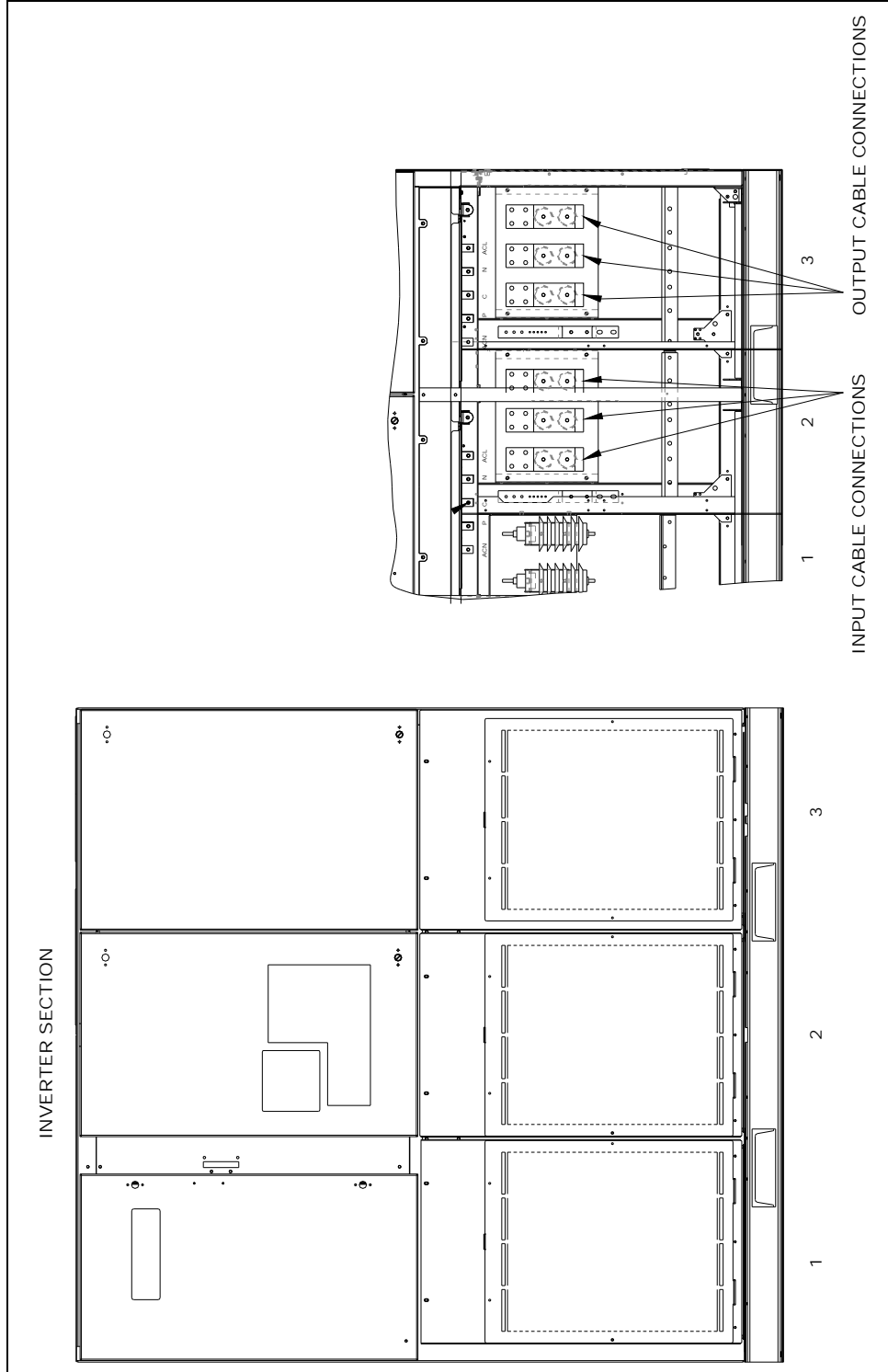

**DRIVE INSTALLATION DRAWINGS (cont'd)**

**Frame 4 module lifting**

**LIFTING PROVISIONS**  
2 LIFTING PROVISIONS ARE AVAILABLE

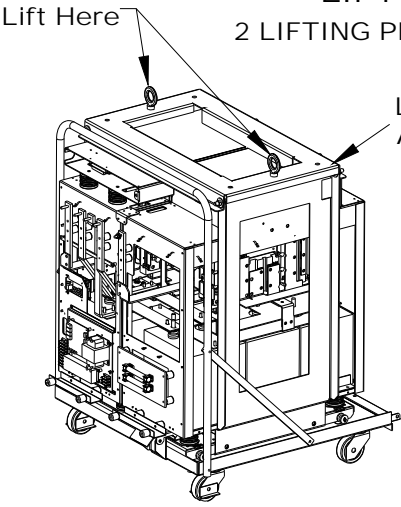

1. Load or remove power module from truck GCI6724G054 using lifting attachment GCI6724G055 and a lifting device rated for 1000 lbs or more.

Secure lifting attachment to power module using (4) 1/2-13 bolts provided.

---

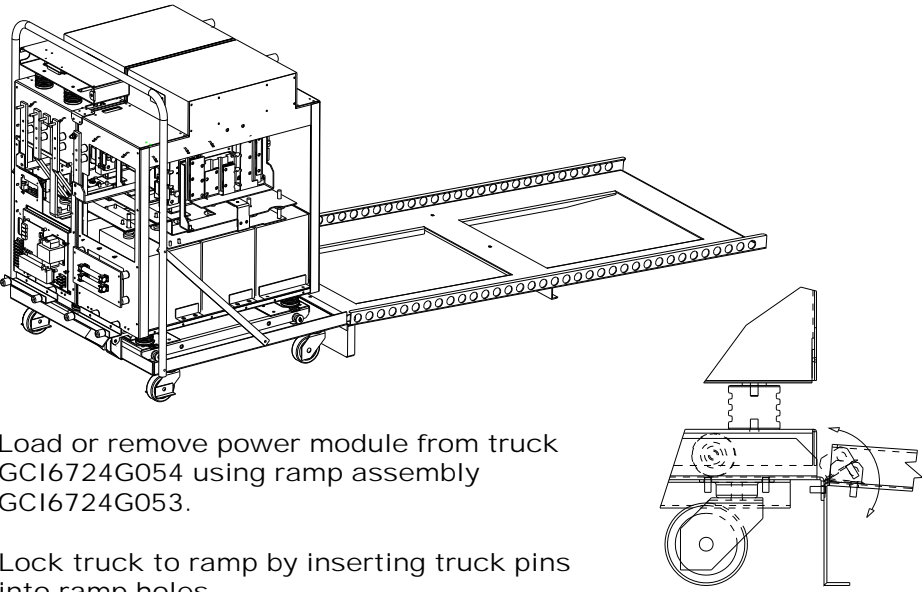

2. Load or remove power module from truck GCI6724G054 using ramp assembly GCI6724G053.

Lock truck to ramp by inserting truck pins into ramp holes.

Set brakes on truck before carefully rolling power module up or down ramp.

PC94060P121

**DRIVE INSTALLATION DRAWINGS (cont'd)**

**Frame 4 2400V module installation**

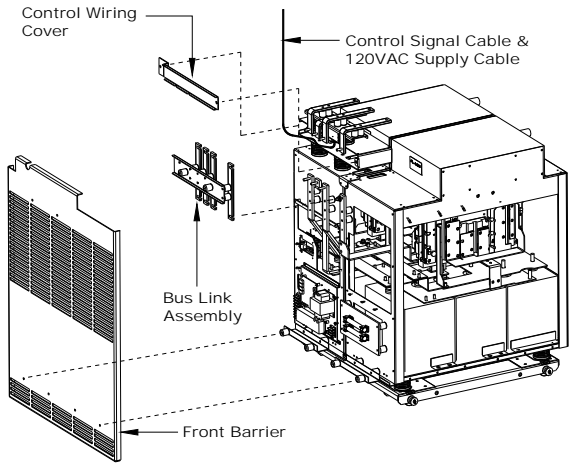
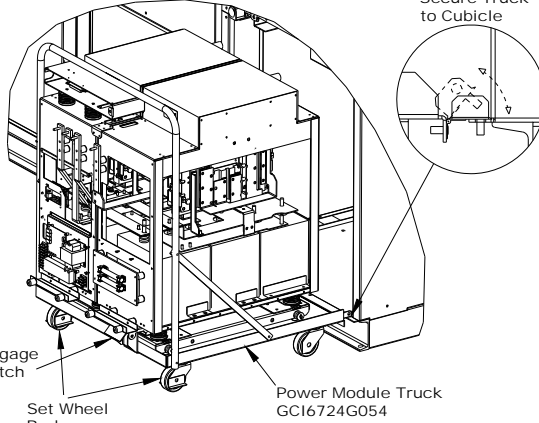
 <p>Control Wiring Cover</p> <p>Control Signal Cable &amp; 120VAC Supply Cable</p> <p>Bus Link Assembly</p> <p>Front Barrier</p> <p><b>POWER MODULE DISCONNECTION</b></p>	 <p>Secure Truck to Cubicle</p> <p>Engage Latch</p> <p>Set Wheel Brakes</p> <p>Power Module Truck GCI6724G054</p> <p><b>POWER MODULE REMOVAL</b></p>		
<p><b>WARNINGS</b> Disconnect power and wait 15 minutes to ensure capacitors are discharged before performing inspection or maintenance.</p> <p>Improper handling of the fiber optic cables and connectors may cause drive failure due to problems transmitting signals. Take care not to disturb fiber optic cables when handling power module.</p>	<p><b>Power Module Disconnection</b></p> <ol style="list-style-type: none"> <li>1. Remove front barrier (six bolts).</li> <li>2. Loosen eight nuts and remove bus link assembly by sliding sideways and off.</li> <li>3. Remove control wiring cover (two bolts)</li> <li>4. Disconnect control signal cable and 120VAC supply cable from module.</li> </ol>	<p><b>Power Module Removal</b></p> <ol style="list-style-type: none"> <li>1. Align truck GCI6724G054 with front of cubicle.</li> <li>2. Secure truck to cubicle by inserting two studs into holes in base.</li> <li>3. Set wheel brakes on truck.</li> <li>4. Roll power module onto truck until front latch engages.</li> <li>5. Refer to additional instruction label for moving power module on and off of truck.</li> </ol>	<p><b>Power Module Reinstallation</b></p> <ol style="list-style-type: none"> <li>1. Reverse the procedure followed during disconnection and removal of power module.</li> <li>2. Ensure that control signal cable and 120VAC supply cable are properly reconnected.</li> <li>3. Reinstall all hardware previously removed.</li> <li>4. Torque bus link connections (5/16-18 hdwr) to 10-15 ft-lbs.</li> </ol> <p>PC94060P174</p>

**DRIVE INSTALLATION DRAWINGS (cont'd)**

**Frame 4 4160V module installation**

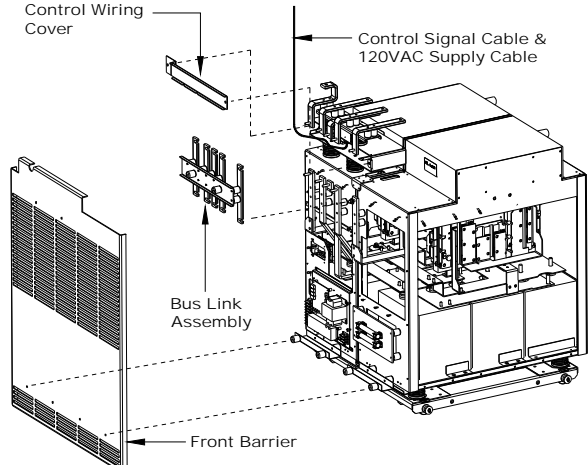
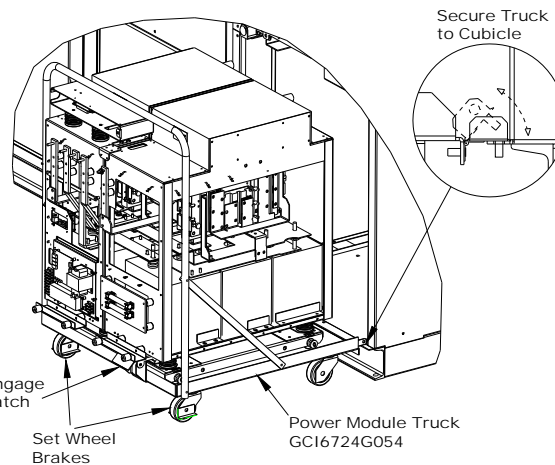
 <p>Control Wiring Cover</p> <p>Control Signal Cable &amp; 120VAC Supply Cable</p> <p>Bus Link Assembly</p> <p>Front Barrier</p> <p><b>POWER MODULE DISCONNECTION</b></p>	 <p>Engage Latch</p> <p>Set Wheel Brakes</p> <p>Power Module Truck GCI6724G054</p> <p>Secure Truck to Cubicle</p> <p><b>POWER MODULE REMOVAL</b></p>		
<p><b>WARNINGS</b> Disconnect power and wait 15 minutes to ensure capacitors are discharged before performing inspection or maintenance.</p> <p>Improper handling of the fiber optic cables and connectors may cause drive failure due to problems transmitting signals. Take care not to disturb fiber optic cables when handling power module.</p>	<p><u>Power Module Disconnection</u></p> <ol style="list-style-type: none"> <li>1. Remove front barrier (six bolts).</li> <li>2. Loosen ten nuts and remove bus link assembly by sliding sideways and off.</li> <li>3. Remove control wiring cover (two bolts)</li> <li>4. Disconnect control signal cable and 120VAC supply cable from module.</li> </ol>	<p><u>Power Module Removal</u></p> <ol style="list-style-type: none"> <li>1. Align truck GCI6724G054 with front of cubicle.</li> <li>2. Secure truck to cubicle by inserting two studs into holes in base.</li> <li>3. Set wheel brakes on truck.</li> <li>4. Roll power module onto truck until front latch engages.</li> <li>5. Refer to additional instruction label for moving power module on and off of truck.</li> </ol>	<p><u>Power Module Reinstallation</u></p> <ol style="list-style-type: none"> <li>1. Reverse the procedure followed during disconnection and removal of power module.</li> <li>2. Ensure that control signal cable and 120VAC supply cable are properly reconnected.</li> <li>3. Reinstall all hardware previously removed.</li> <li>4. Torque bus link connections (5/16-18 hdwr) to 10-15 ft-lbs.</li> </ol> <p style="text-align: right;">PC94060P120</p>

## DRIVE INSTALLATION DRAWINGS (cont'd)

### Frame G4P drive lifting and assembly

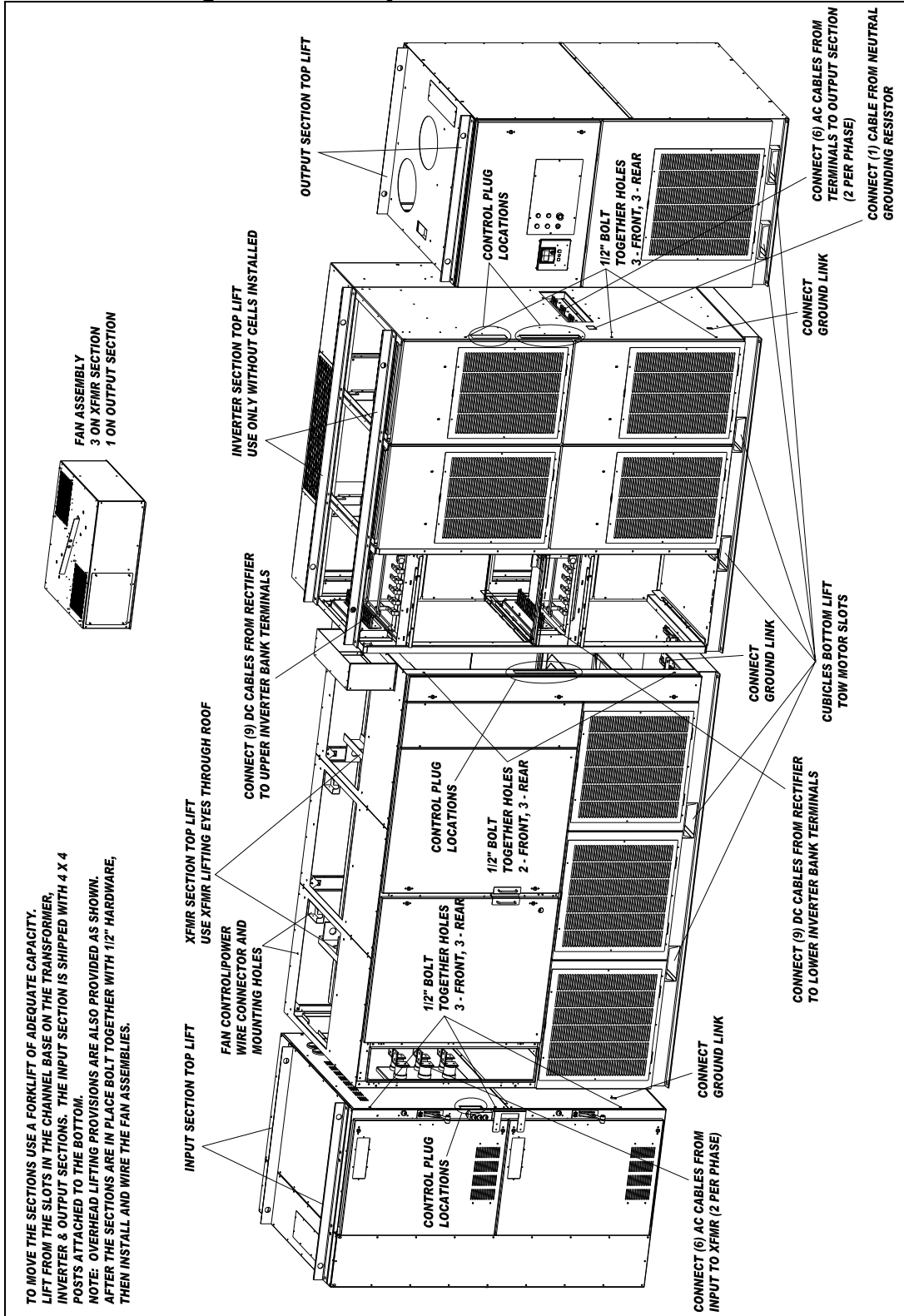

## DRIVE INSTALLATION DRAWINGS (cont'd)

### Frame G4P drive main cable installation

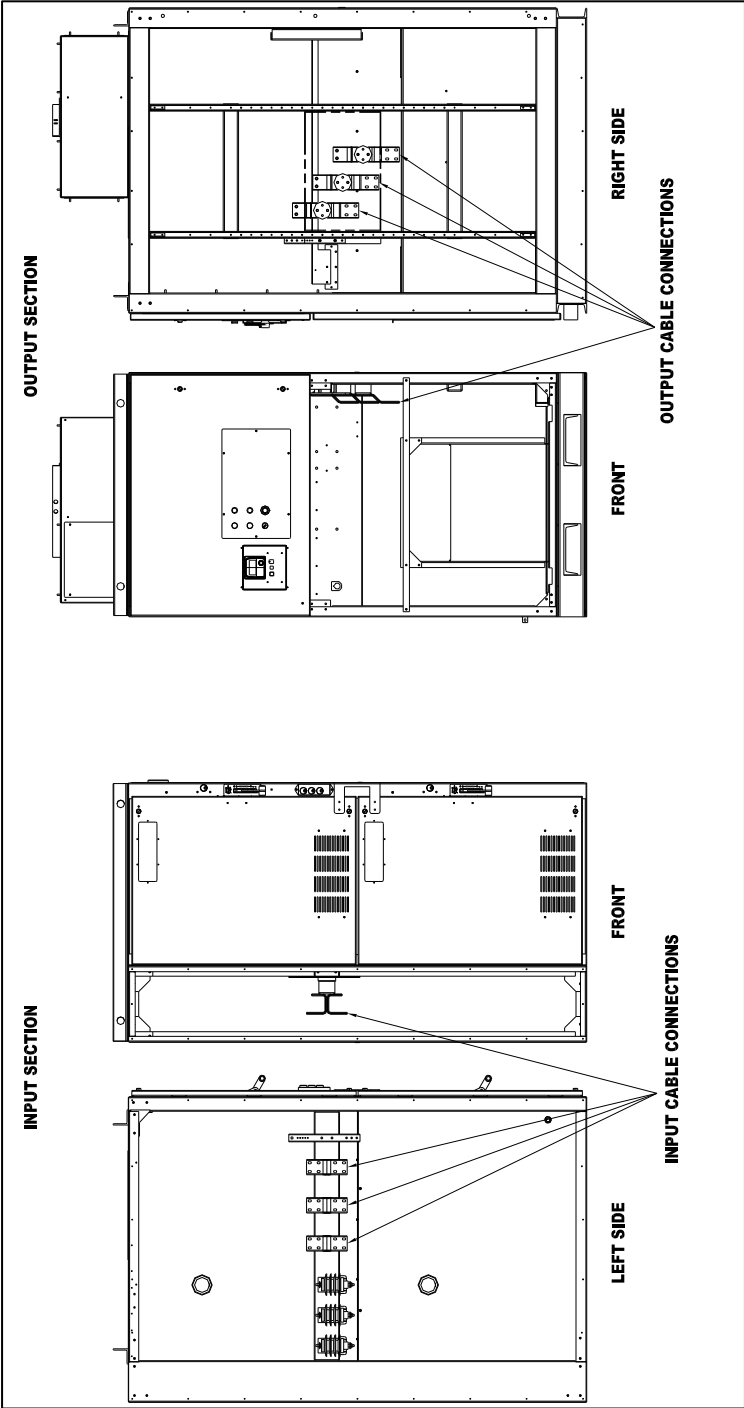

## DRIVE INSTALLATION DRAWINGS (cont'd)

### Frame G4P module lifting and installation

#### WARNINGS

Disconnect power and wait 15 minutes to ensure capacitors are discharged before performing inspection or maintenance.

Improper handling of the fiber optic cables and connectors may cause drive failure due to problems transmitting signals. Take care not to disturb fiber optic cables when handling power module.

Use Lift PC10480P910 for removal & installation of modules

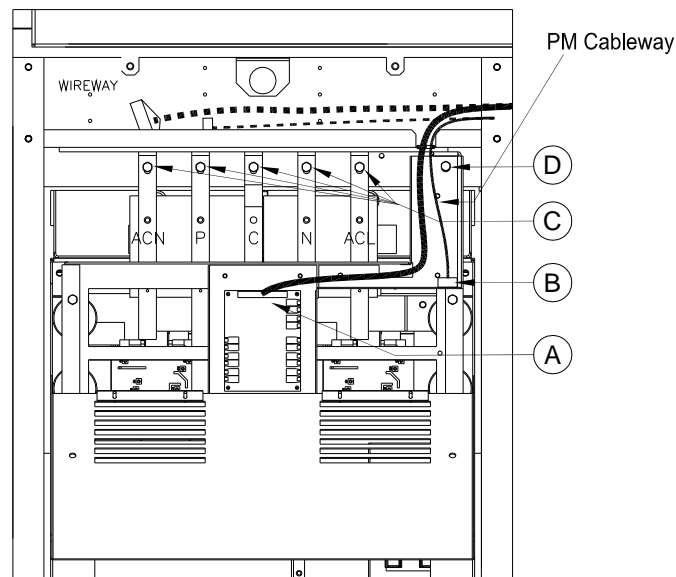

#### Power Module Removal

1. After capacitor discharge, open upper Power Module cover.
2. Disconnect Control Cable from PCB 'A' and lay in wireway above Power Module.
3. Disconnect Control Power Cable 'B', lay in wireway above Power Module.
4. Remove (5) bolts 'C' from bus stabs ACN, P, C, N & ACL
5. Remove (1) bolt 'D' from back of Power Module cableway.
6. Raise tray of lifter PC10480P910 above Power Module support pan. Lower tray inserting tray pins into holes in front edge of support pan. (E) Set truck brake.
7. Withdraw Power Module by handles onto tray. Secure Power Module to tray by connecting chains to Power Module handles.(F)
8. Raise tray to until pins are clear of mounting pan. Slowly move lifter back, away from cubicle. Use crank to slowly lower Power Module to the floor.

PC94060P191

**DRIVE INSTALLATION DRAWINGS (cont'd)**

**Frame G4P module lifting and installation continued**

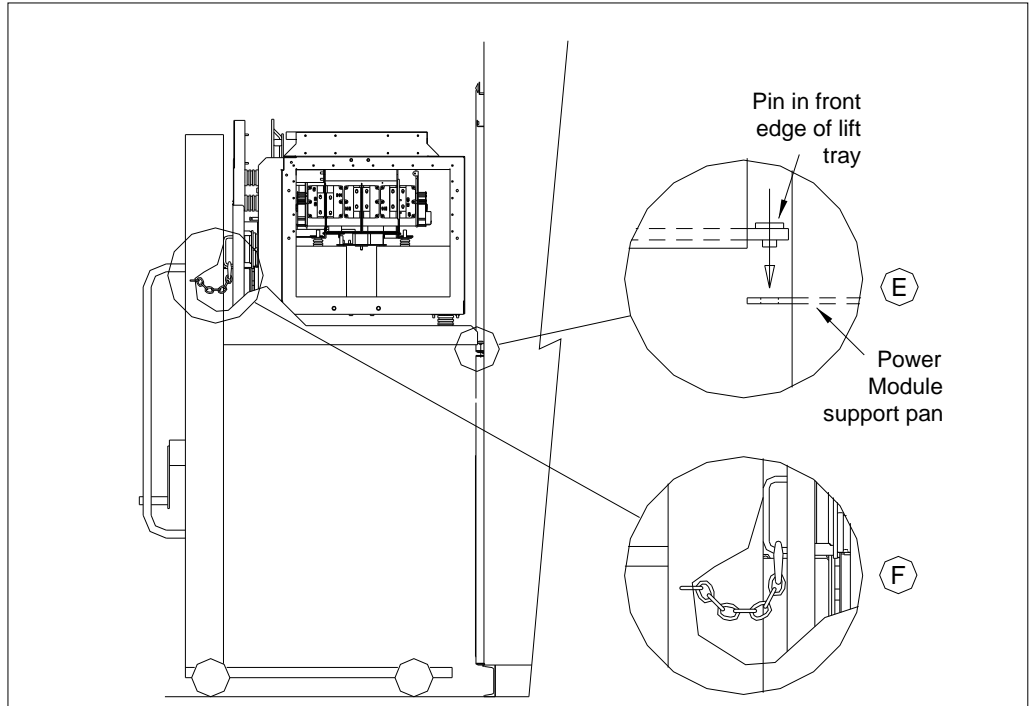

**Power Module Installation**

1. Lower lifter tray to ground. Roll Power Module onto tray. Secure with chains.(F)
2. Raise tray above Power Module support pan. Lower tray, inserting pins into holes in front edge of support pan. (E) Set truck brake.
3. Unlatch chains. Roll Power Module by handles from truck onto enclosure rail until enclosure and Power Module bus stabs touch.
4. Install (1) bolt 'D' at back of cableway. Unlock, remove truck.
5. Install (5) bolts 'C' through bus stabs ACN, P, C, N & ACL. Torque all power connections (5/16-18 hdwr) to 10-15 ft-lbs.
6. Connect Control Power Cable from wireway as shown at 'B'.
7. Connect Control Cable from wireway to PCB as shown at 'A'.
8. Close upper Power Module cover. Secure with 2 bolts.
9. Replace outside filter cover.

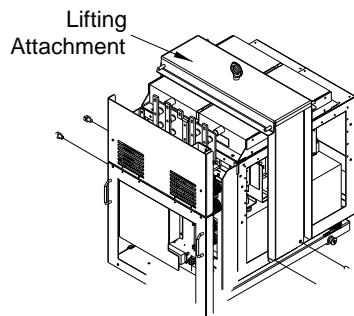

For lifting the Power Module after it is out of the Cubicle use Lifting Attachment GCI6723G054 and a lifting device rated at 1000 lbs. or more.

Secure Lifting Attachment to Power Module with (4) ½-13 Bolts.

## DRIVE INSTALLATION DRAWINGS (cont'd)

### Frame H4P drive lifting and assembly

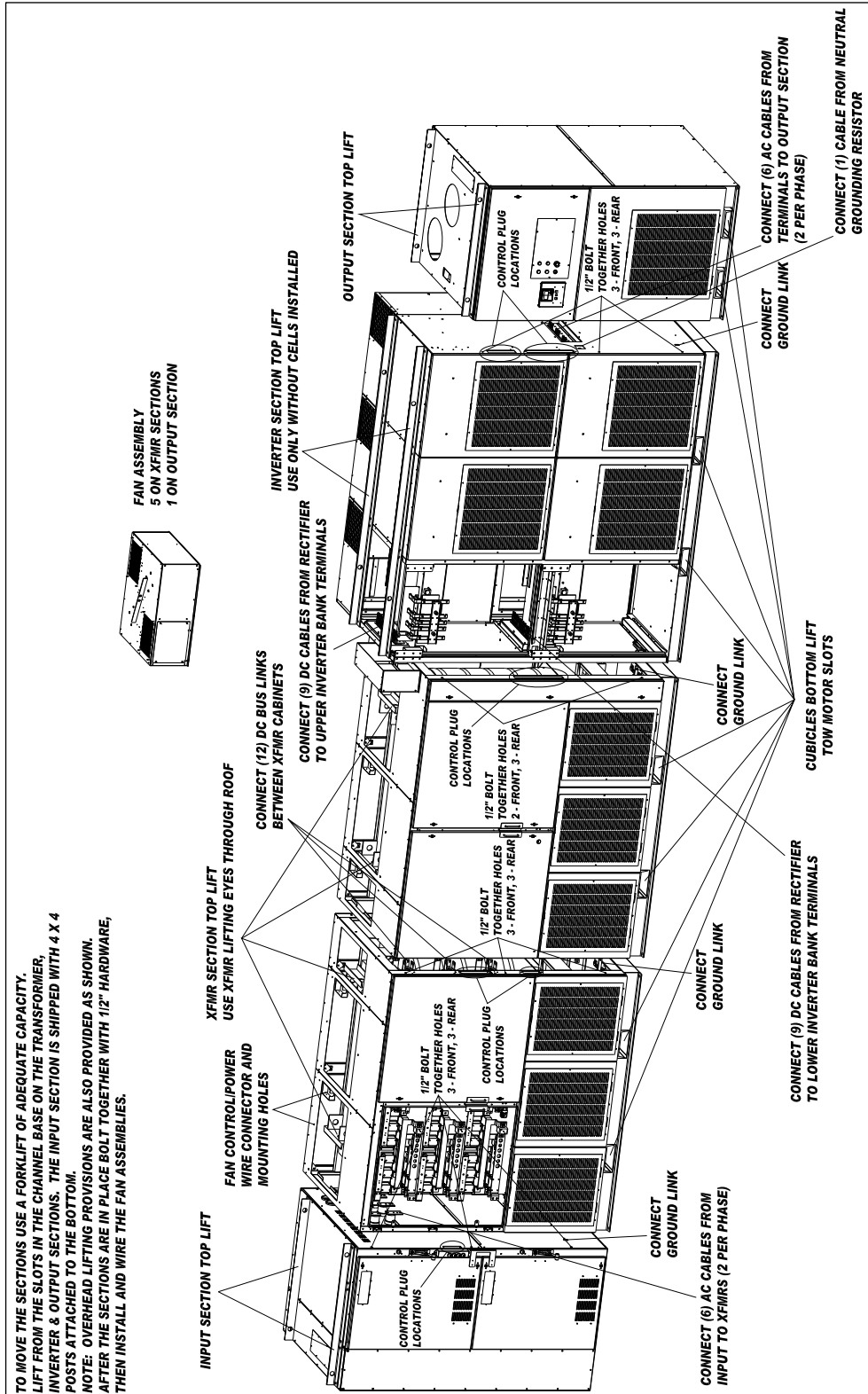

**DRIVE INSTALLATION DRAWINGS (cont'd)**

**Frame H4P drive main cable installation**

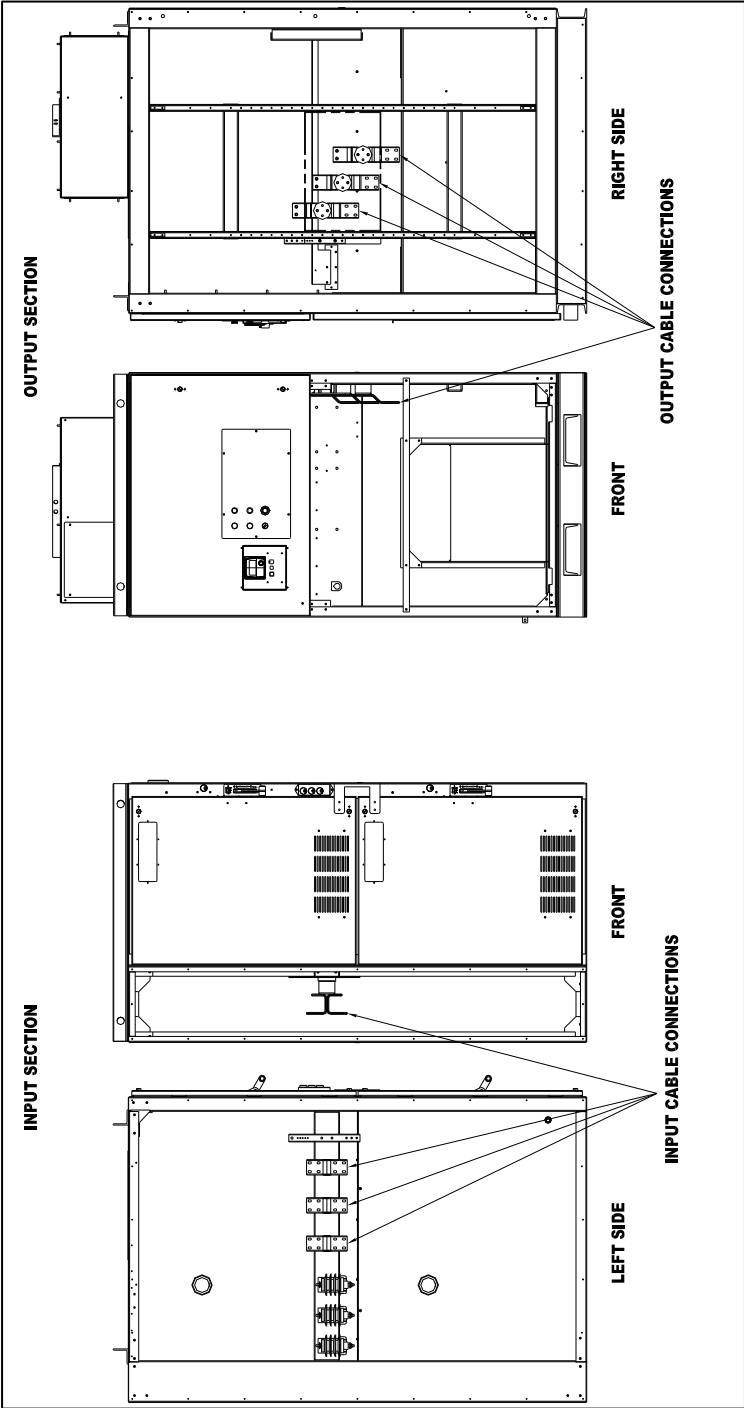

## DRIVE INSTALLATION DRAWINGS (cont'd)

### Frame H4P module lifting and installation

#### WARNINGS

Disconnect power and wait 15 minutes to ensure capacitors are discharged before performing inspection or maintenance.

Improper handling of the fiber optic cables and connectors may cause drive failure due to problems transmitting signals. Take care not to disturb fiber optic cables when handling power module.

Use Lift PC10480P910 for removal & installation of modules

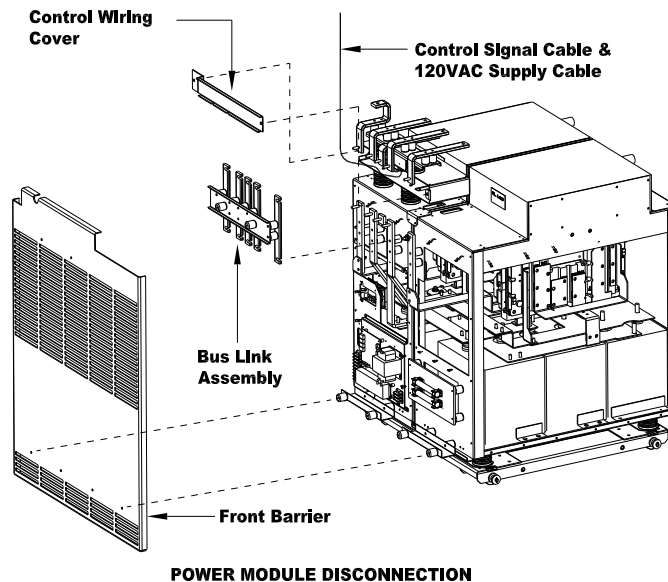

#### Power Module Disconnection

1. Remove front barrier (six bolts).
2. Loosen ten nuts and remove bus link assembly by sliding sideways and off.
3. Remove control wiring cover (two bolts)
4. Disconnect control signal cable and 120VAC supply cable from module.

#### Power Module Removal

1. Position lifter squarely in front of cubicle. Raise tray of lifter PC10480P910 above Power Module support pan. Lower tray inserting tray pins into holes in front edge of support pan. (A) Set truck brake.
2. Withdraw Power Module onto lifter tray. Secure Power Module to tray by looping and latching chain or cable through right side of chassis.(B)
3. Raise tray to until pins are clear of support pan. Slowly move lifter back, away from cubicle. Use crank to slowly lower Power Module to the floor.

PC94060P193

**DRIVE INSTALLATION DRAWINGS (cont'd)**

**Frame H4P module lifting and installation continued**

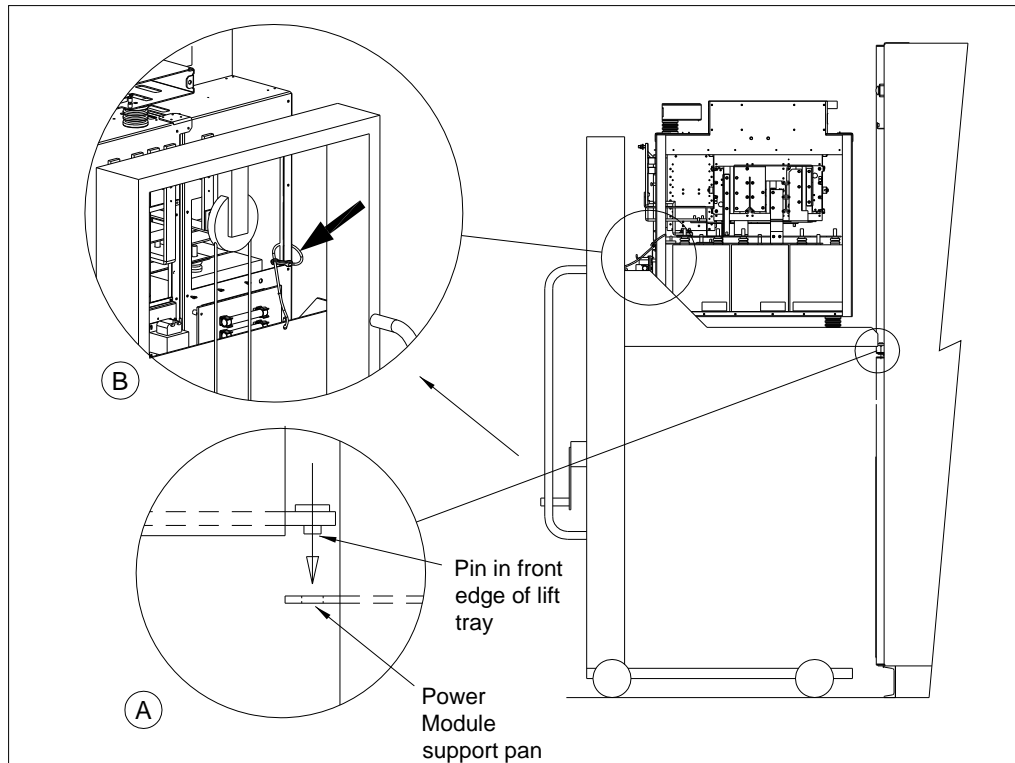

**Power Module Installation**

1. Lower lifter tray to ground. Roll Power Module onto tray. Secure Power Module.(B)
2. Raise tray above Power Module support pan. Lower tray, inserting pins into holes in front edge of support pan. (A) Set truck brake.
3. Unlatch Power Module (B). Roll Power Module from truck onto enclosure rails.

**Power Module Reconnection**

1. Reverse the procedure followed during disconnection and removal of Power Module.
2. Ensure that control signal cable and 120VAC supply cable are properly reconnected.
3. Reinstall all hardware previously removed.
4. Torque bus link connections (5/16-18 hdwr) to 10-15 ft-lbs.

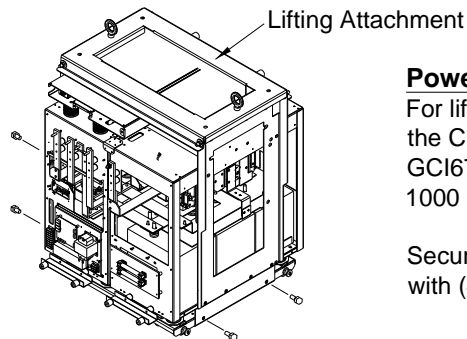

**Power Module Lifting**

For lifting the Power Module after it is out of the Cubicle use Lifting Attachment GCI6724G055 and a lifting device rated at 1000 lbs. or more.

Secure Lifting Attachment to Power Module with (4) ½ -13 Bolts.

PC94060P194

**DRIVE INSTALLATION DRAWINGS (cont'd)**

**Frame A2 module lifting and installation**

**WARNINGS:**

Disconnect power and wait 15 minutes to ensure capacitors are discharged before performing inspection or maintenance.

Improper handling of the fiber optic cables and connectors may cause drive failure due to problems transmitting signals. Take care when handling fiber optic cables.

**REMOVING A SINGLE PHASE POWER MODULE**

1. After 15 minute capacitor discharge time, remove front barrier, (4) bolts. Figure 1.
2. Disconnect OLB Cable from bottom of Cell. Access from below through LV Compartment. Figure 2.
3. Disconnect PCB connectors marked CN1 and CN5. Figure 3. Set wires up on support rail to avoid snagging during cell removal.
4. Remove bus connection bolts (4). Figure 3.
5. Remove cell mounting nuts (2). Figure 3.
6. Slide cell forward and remove from cabinet. Figure 4.
7. Replace cell by following the steps above in reverse order.

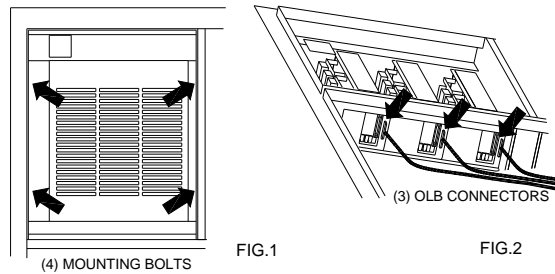

**REMOVING THE THREE PHASE CELL ASSEMBLY**

Use lifting attachment GCI673AG055 and a lifting device rated 300 lbs minimum for removal and installation of Three Phase Cell Assembly.

1. After 15 minute capacitor discharge time, remove front barrier, (4) bolts. Figure 1.
  2. Disconnect (3) OLB Cables from bottom of the Cells. Access from below through LV Compartment. Figure 2.
  3. Remove bus connection bolts (6) on top of assembly. Figure 6.
  4. Disconnect AC power connector (1). Slide wires down access cutout into L.V. compartment before proceeding to the next step. Fig. 4 and 6.
  5. Remove slide release bolts (2). Figure 6.
  6. Slide assembly forward until slides lock. Figure 7.
  7. Install Lifting Attachment GCI673AG055. Bolt (4) places. Fig. 7.
  8. Remove assembly mounting bolts (4). (2) in front edge, (2) behind cells through base panel. Figure 7.
  9. Lift assembly off tray with a lifting device rated for 300 lbs or more.
- Replace cell by following the steps above in reverse order.  
Release all slide locks before sliding assembly back into cubicle.

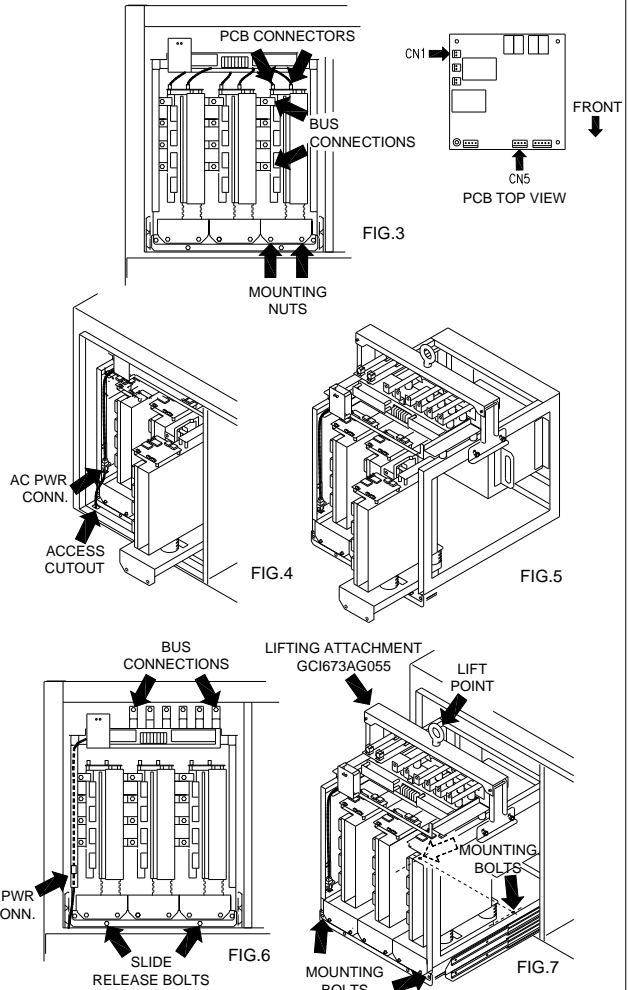

**DRIVE INSTALLATION DRAWINGS (cont'd)**

**Frame A2 drive lifting and assembly**

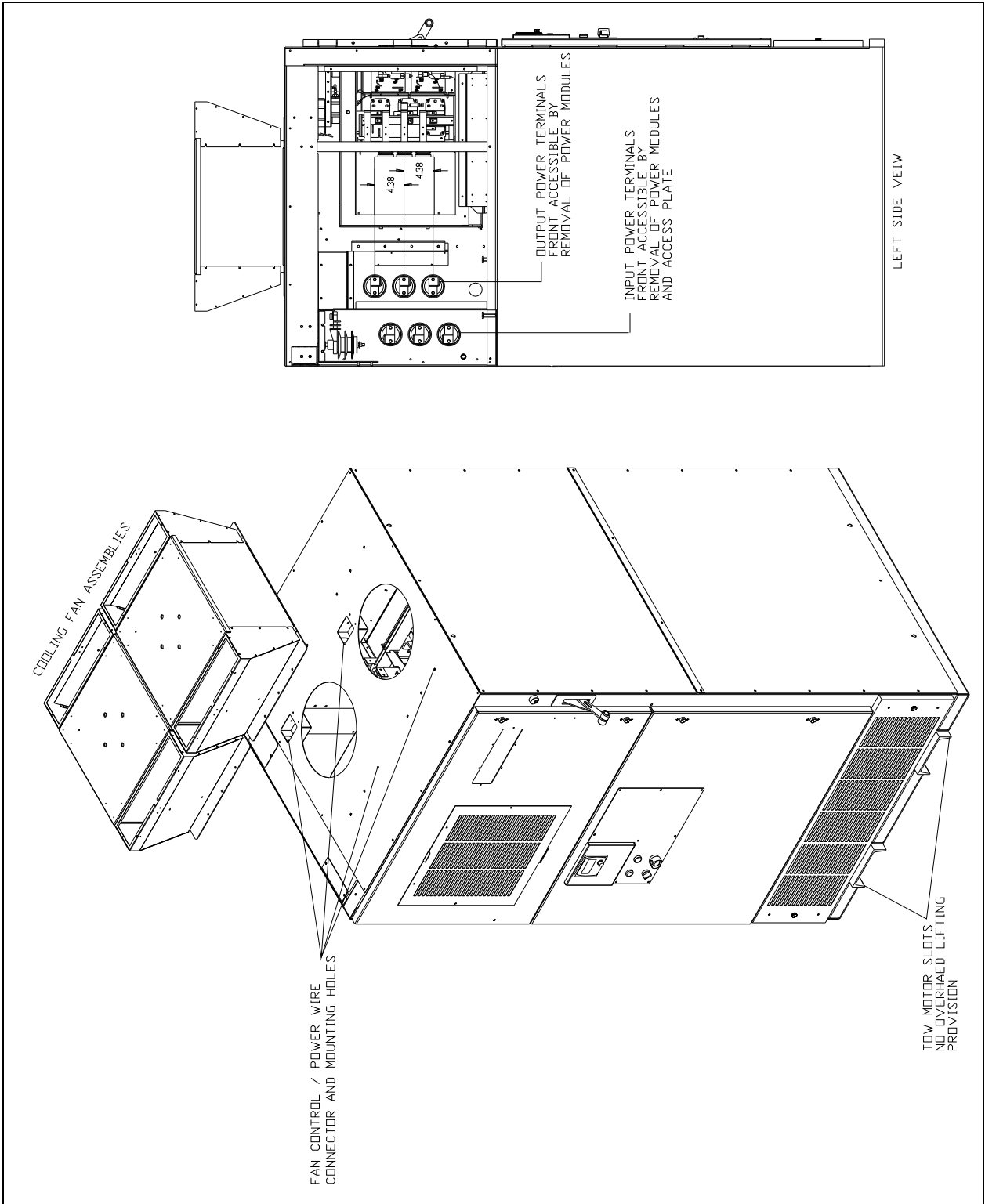

## DRIVE INSTALLATION DRAWINGS (cont'd)

### Frame B2 2400V module lifting and installation Type 1

<p><b>WARNINGS</b></p>	<p>Disconnect power and wait 15 minutes to ensure capacitors are discharged before performing inspection or maintenance.</p>	<p>Improper handling of the fiber optic cables and connectors may cause drive failure due to problems transmitting signals. Take care when handling fiber optic cables.</p>	<p>Use module lifting attachment GC1673BG055 and a lifting device rated 125 lbs minimum for removal and installation of modules.</p>
<p><b>Power Module Removal</b></p> <ol style="list-style-type: none"> <li>1. Lift latch and lower shelf to service position.</li> <li>2. Disconnect ACL power cable.</li> <li>3. Disconnect control plug.</li> <li>4. Disconnect P, C &amp; N bus bars by removing hardware "A".</li> <li>5. Remove bolt "B".</li> <li>6. Slide module out of compartment and onto shelf.</li> <li>7. Disconnect four (4) fiber optic cables from module.</li> <li>8. Using module lifting attachment and lifter, lift module from shelf.</li> </ol> <p><b>Power Module Installation</b></p> <ol style="list-style-type: none"> <li>1. Lower shelf to service position.</li> <li>2. Using module lifting attachment and lifter, place module on shelf.</li> <li>3. Reconnect four (4) fiber optic cables to module.</li> <li>4. Align module and push into compartment until it stops.</li> <li>5. Reinstall bolt "B".</li> <li>6. Install previously removed hardware "A" to connect P, C &amp; N bus bars.</li> <li>7. Reconnect control plug.</li> <li>8. Reconnect ACL power cable.</li> <li>9. Torque P, C, N &amp; ACL connections (5/16-18 hdwr) to 10-15 ft-lbs.</li> <li>10. Push shelf back up and latch in stowed position.</li> </ol>			

PC94060P198

**DRIVE INSTALLATION DRAWINGS (cont'd)**

**Frame B2 module lifting and installation Type 2**

<p><u>WARNINGS</u></p>	<p>Disconnect power and wait 15 minutes to ensure capacitors are discharged before performing inspection or maintenance.</p>	<p>Improper handling of the fiber optic cables and connectors may cause drive failure due to problems transmitting signals. Take care when handling fiber optic cables.</p>	<p>Use module lifting attachment GC1673BG055 and a lifting device rated 125 lbs minimum for removal and installation of modules. Lifting attachment is stored inside the Power Module Compartment.</p>
<div style="display: flex;"> <div style="flex: 1;"> <p><u>Power Module Removal</u></p> <ol style="list-style-type: none"> <li>1. Disconnect ACL power cable.</li> <li>2. Disconnect control plug.</li> <li>3. Disconnect P, C &amp; N bus bars by removing hardware "A".</li> <li>4. Remove bolt "B".</li> <li>5. Slide lifting attachment into module extension guide and fasten lifting attachment using bolt "C".</li> <li>6. Pull module out into lifting attachment.</li> <li>7. Latch module (see "LATCH DETAIL").</li> <li>8. Disconnect four (4) fiber optic cables from module.</li> <li>9. Couple lifting device to lifting attachment.</li> <li>10. Unfasten bolt "C".</li> <li>11. Using lifting device, slide power module and lifting attachment together out of module extension guide.</li> </ol> <p><u>Power Module Installation</u></p> <ol style="list-style-type: none"> <li>1. Using lifting device, insert module with lifting attachment into module extension guide.</li> <li>2. Fasten bolt "C".</li> <li>3. Reconnect four (4) fiber optic cables to module.</li> <li>4. Lift latch, align module and push into compartment until module bus bars are flush with P, C, &amp; N bus bars.</li> <li>5. Unfasten bolt "C".</li> <li>6. Remove lifting attachment by sliding it out of module extension guide.</li> <li>7. Reinstall bolt "B".</li> <li>8. Install previously removed hardware "A" to connect P, C &amp; N bus bars.</li> <li>9. Reconnect control plug.</li> <li>10. Reinstall previously removed ACL cable.</li> <li>11. Torque P, C, N &amp; ACL connections (5/16-18 hdwr) to 10-15 ft-lbs.</li> </ol> </div> <div style="flex: 2;"> </div> </div>			

**DRIVE INSTALLATION DRAWINGS (cont'd)**

**Frame B2 drive lifting and assembly**

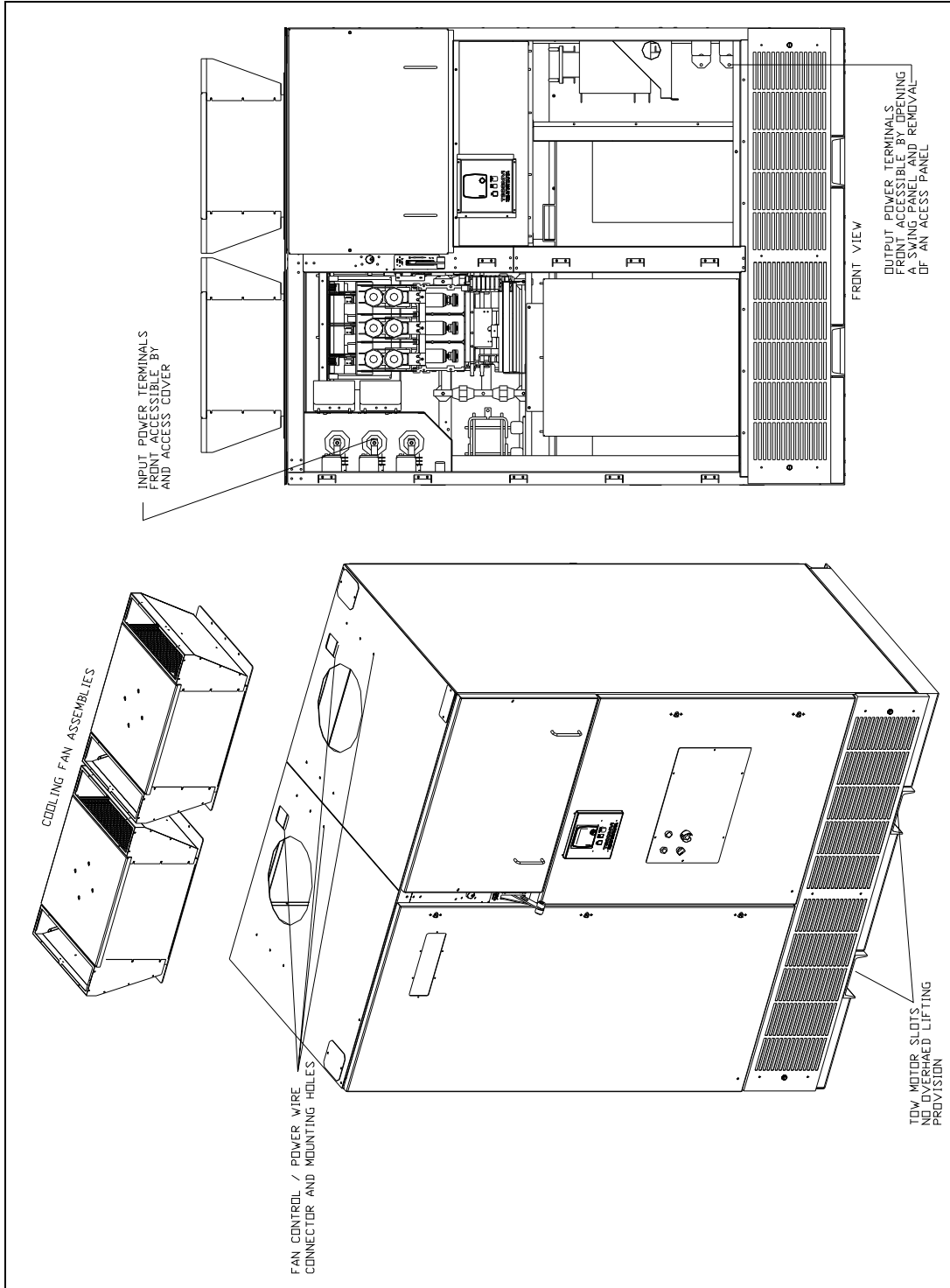

**DRIVE INSTALLATION DRAWINGS (cont'd)**

**Frame D2 module lifting and assembly**

**! DANGER**



**TOP HEAVY EQUIPMENT**

Cabinet Can Tip Over Causing Serious Injury or Death.

Do Not Attempt to Withdraw Power Modules Without First Securely Anchoring Equipment to Floor.

PC94060P007

**! DANGER**

When the service drawer is withdrawn, the power modules have sufficient weight to tip over the Frame D2 inverter cabinet if it is not firmly anchored to the mounting floor, resulting in severe injury or death.

**DO NOT** attempt to install or withdraw the Frame D2 power modules before first securely anchoring the cabinet to the floor.

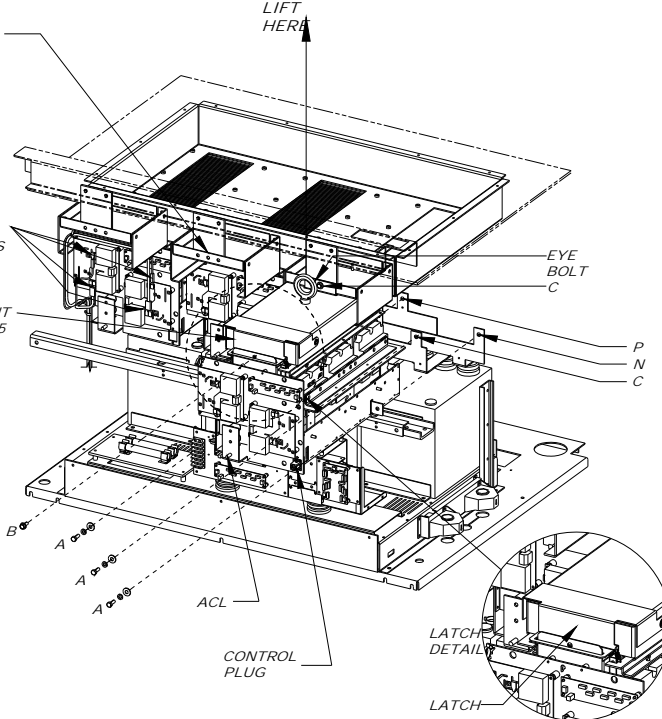
<p><b>WARNINGS</b></p>	<p>Disconnect power and wait 15 minutes to ensure capacitors are discharged before performing inspection or maintenance.</p>	<p>Improper handling of the fiber optic cables and connectors may cause drive failure due to problems transmitting signals. Take care when handling fiber optic cables.</p>	<p>Use module lifting attachment GC1673DG055 and a lifting device rated 200 lbs minimum for removal and installation of modules. Lifting attachment is stored inside low voltage compartment door.</p>
<p><b>Power Module Removal</b></p> <ol style="list-style-type: none"> <li>1. Disconnect ACL power cable.</li> <li>2. Disconnect control plug.</li> <li>3. Disconnect P, C &amp; N bus bars by removing hardware "A".</li> <li>4. Remove bolt "B".</li> <li>5. Disconnect four (4) fiber optic cables from module.</li> <li>6. Slide lifting attachment into module extension guide and fasten lifting attachment using bolt "C".</li> <li>7. Pull module out into lifting attachment.</li> <li>8. Latch module (see "LATCH DETAIL").</li> <li>9. Couple lifting device to lifting attachment using "EYE BOLT".</li> <li>10. Unfasten bolt "C".</li> <li>11. Using lifting device, slide power module and lifting attachment together out of module extension guide.</li> </ol>			
<p><b>Power Module Installation</b></p> <ol style="list-style-type: none"> <li>1. Using lifting device, insert module with lifting attachment into module extension guide.</li> <li>2. Fasten bolt "C".</li> <li>3. Lift latch, align module and push into compartment until module bus bars are flush with P, C, &amp; N bus bars.</li> <li>4. Unfasten bolt "C".</li> <li>5. Remove lifting attachment by sliding it out of module extension guide.</li> <li>6. Reinstall bolt "B".</li> <li>7. Reconnect four (4) fiber optic cables to module.</li> <li>8. Install previously removed hardware "A" to connect P, C &amp; N bus bars.</li> <li>9. Reconnect control plug.</li> <li>10. Reinstall previously removed ACL cable.</li> <li>11. Torque P, C, N &amp; ACL connections (5/16-18 hwdr) to 10-15 ft-lbs.</li> </ol>		<p><small>PC94060P199</small></p>	

**DRIVE INSTALLATION DRAWINGS (cont'd)**

**Frame D2 drive lifting and assembly**

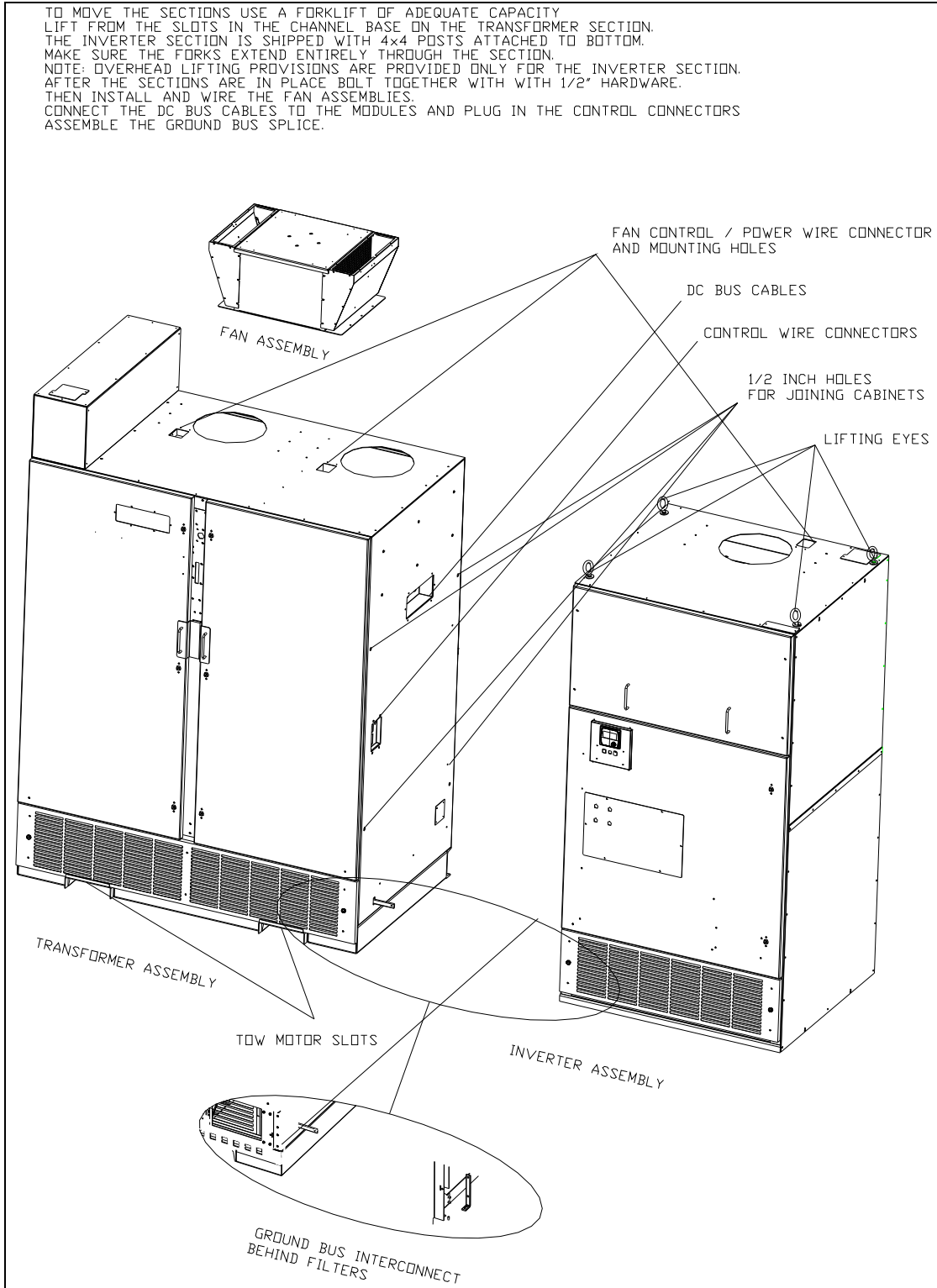

**DRIVE INSTALLATION DRAWINGS (cont'd)**

**Frame D2 drive main terminal locations**

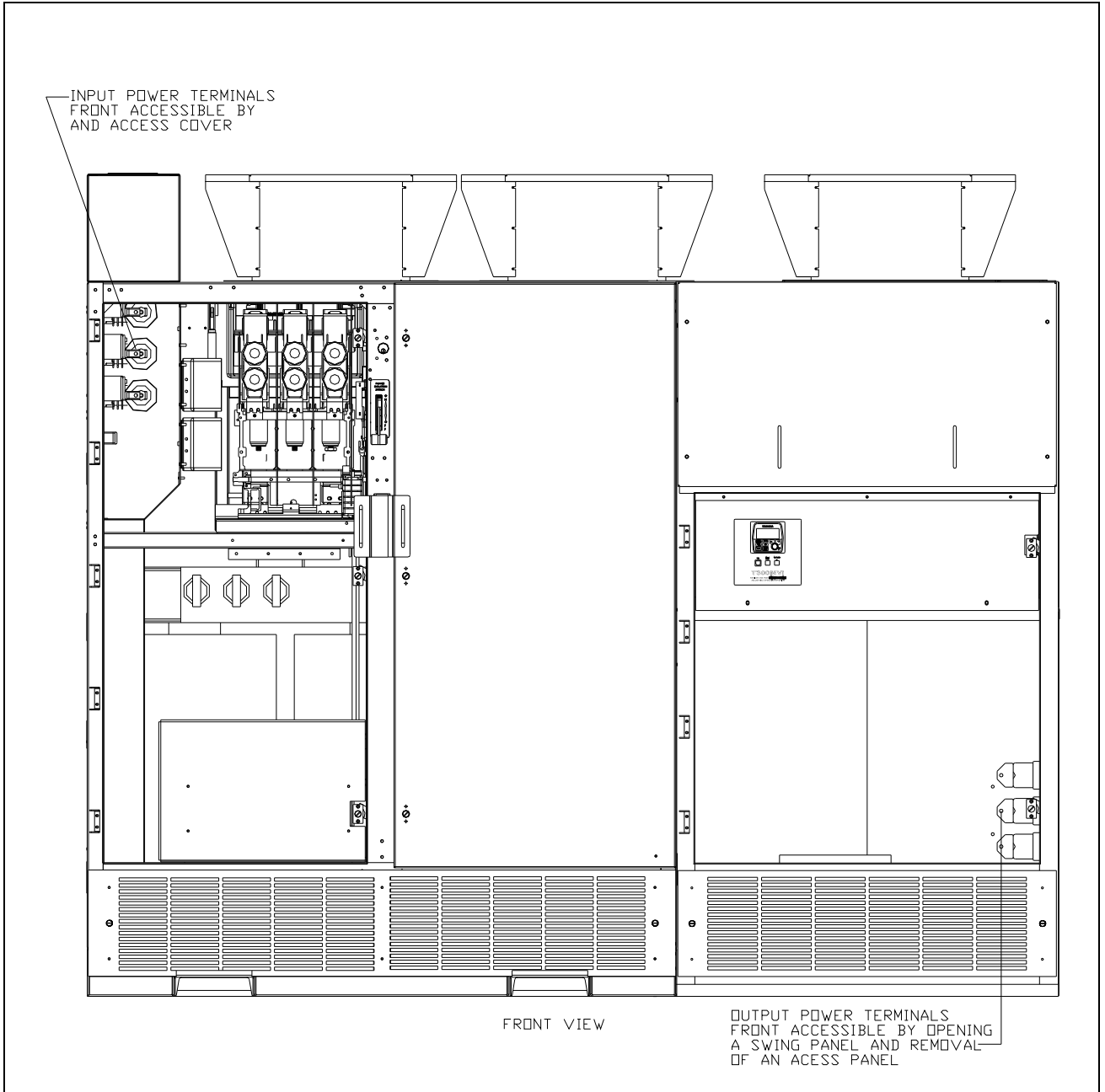

**DRIVE INSTALLATION DRAWINGS (cont'd)**

**Frame A4μ module lifting and installation**

**WARNINGS:**

Disconnect power and wait 15 minutes to ensure capacitors are discharged before performing inspection or maintenance.

Improper handling of the fiber optic cables and connectors may cause drive failure due to problems transmitting signals. Take care when handling fiber optic cables.

**REMOVING/REPLACING POWER MODULE**

1. After 15 minute capacitor discharge time, remove front barrier, four "A" bolts. Figure 1.
2. Disconnect AC Neutral Cable. Disconnect and remove AC Neutral Bus. Figure 2.
3. Disconnect Power Cables P,C,N & ACL. Figure 2.
4. Disconnect Control Signal Cable and 120VAC Supply Cable from bottom of Cell. Access from below through LV Compartment. Figure 3.
5. Free slide tray by removing two "B" bolts. Figure 4.
6. Pull slide tray out until slides lock. Figure 4.
7. Remove four "C" bolts which secure module to tray.
8. Use a lifting device rated for 200 pounds or more to lift module from tray by module lifting hole.
9. Replace module by following the steps above in reverse order. Press buttons on inside slide surfaces to slide tray back. Torque power connections (10-32 nuts) to 30 inch-lbs.

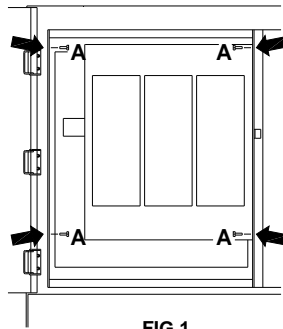

FIG.1

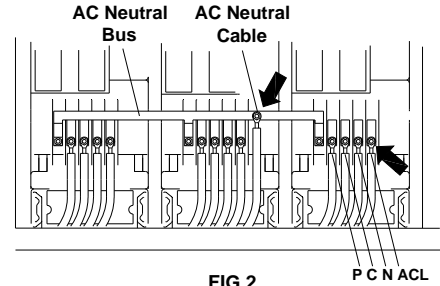

FIG.2

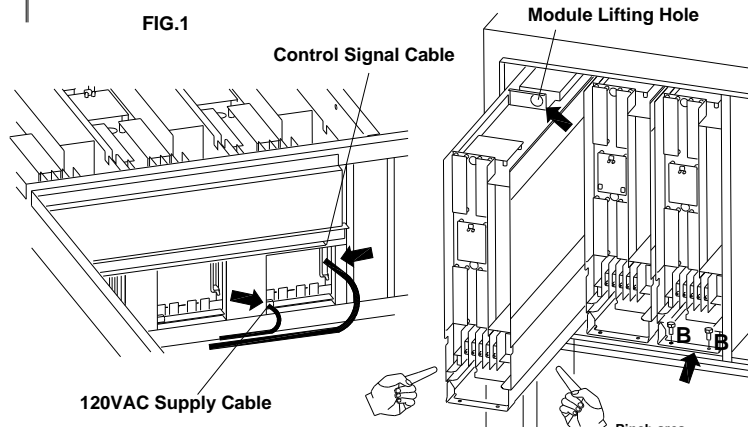

FIG.3

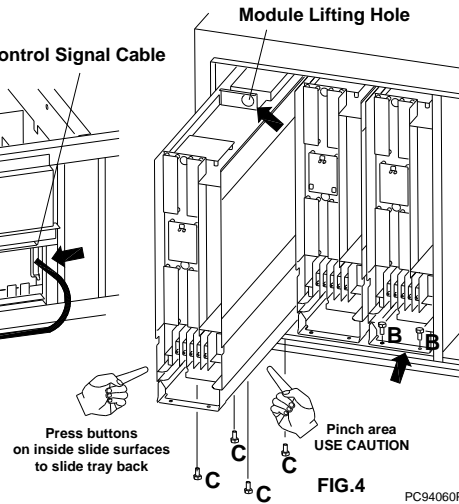
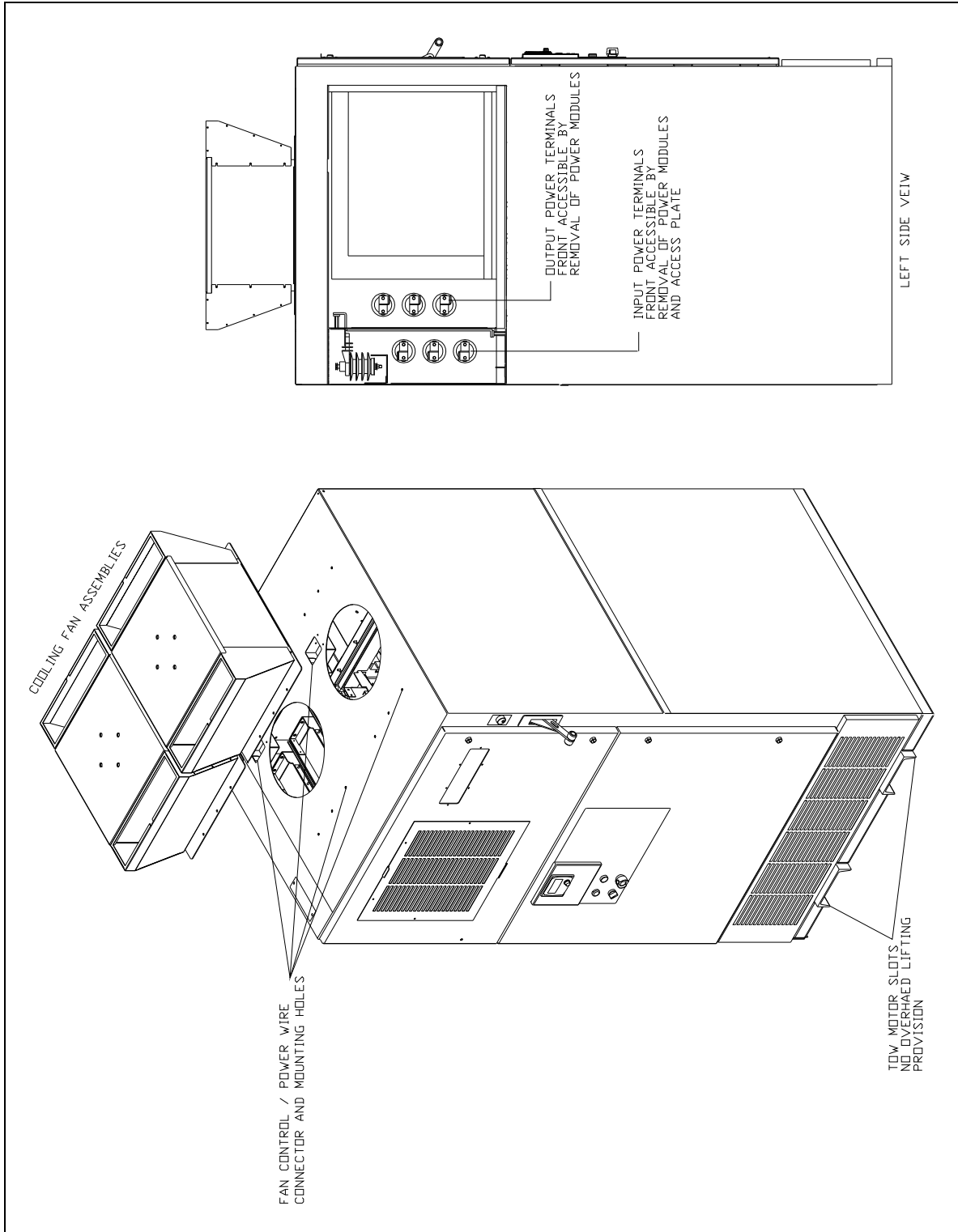

FIG.4

PC94060P214

**DRIVE INSTALLATION DRAWINGS (cont'd)**

**Frame A4 $\mu$  drive lifting and assembly**



**DRIVE INSTALLATION DRAWINGS (cont'd)**

**Frame A4 module lifting and installation**

**WARNINGS**

Disconnect power and wait 15 minutes to ensure capacitors are discharged before performing inspection or maintenance.

Improper handling of the fiber optic cables and connectors may cause drive failure due to problems transmitting signals. Take care not to disturb fiber optic cables when handling power module.

Use module lifting attachment GC16720G055 and a lifting device rated 250 lbs minimum for removal and installation of modules.

**Power Module Removal**

1. Disconnect and remove AC neutral bus.
2. Disconnect power cables ACL, P, C & N.
3. Remove control wiring cover (two "A" bolts)
4. Disconnect control signal cable and 120VAC supply cable from module.
5. Free slide tray by removing bolt "B".
6. Pull slide tray out until slides lock.
7. Remove four "C" bolts which secure module to tray.

**Power Module Removal (cont'd)**

8. Using module lifting attachment and lifter, lift module from tray.

**Power Module Installation**

1. Pull slide tray out until slides lock.
2. Using module lifting attachment and lifter, place module on tray.
3. Secure module to tray with four "C" bolts.
4. Press slide release buttons and slide module into compartment (use caution).
5. Reinstall bolt "B" to secure tray in position.
6. Reconnect control signal cable and 120VAC supply cable to module connectors.
7. Reinstall control wiring cover and secure with two "A" bolts.
8. Reconnect power cables ACL, P, C & N.
9. Reinstall AC neutral bus.
10. Torque all power connections (5/16-18 hdwr) to 10-15 ft-lbs.

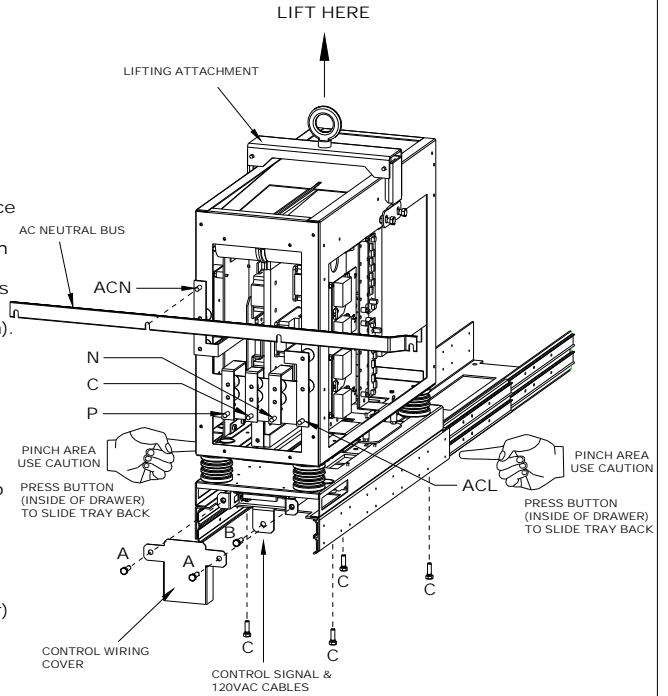

PC94060P086

**DRIVE INSTALLATION DRAWINGS (cont'd)**

**Frame A4 drive lifting and assembly**

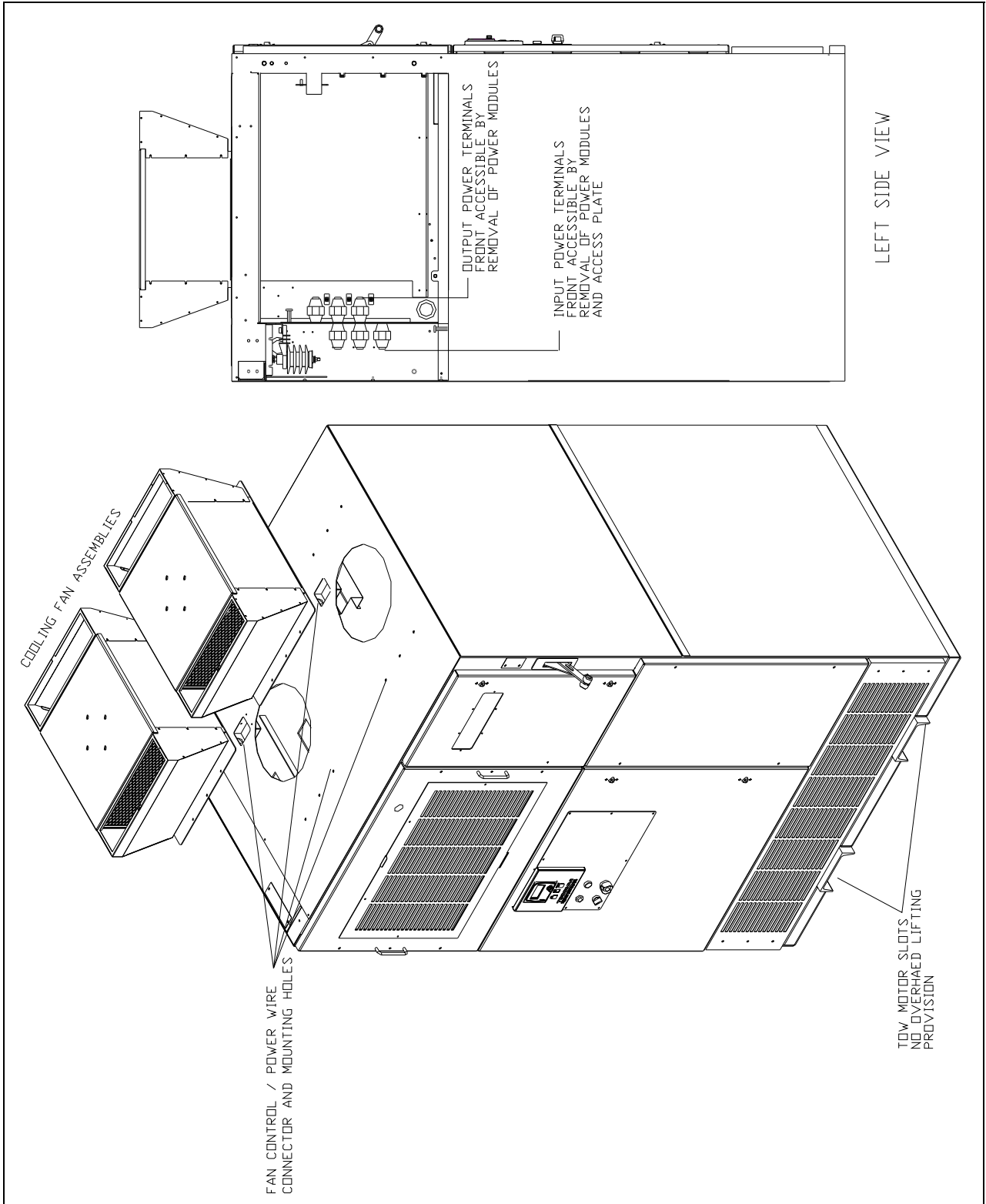

## DRIVE INSTALLATION DRAWINGS (cont'd)

### Frame B4 module lifting and installation

#### WARNINGS

Inverter cabinet is top heavy. Cabinet must be anchored to floor before withdrawing power modules to prevent tipping.

Disconnect power and wait 15 minutes to ensure capacitors are discharged before performing inspection or maintenance.

Improper handling of the fiber optic cables and connectors may cause drive failure due to problems transmitting signals. Take care not to disturb fiber optic cables when handling power module.

Use module lifting attachment GC16721G055 and a lifting device rated 350 lbs minimum for removal and installation of modules.

#### Power Module Removal

1. Disconnect and remove AC neutral bus.
2. Disconnect power cables ACL, P, C & N.
3. Remove control wiring cover with two "A" & two "B" bolts
4. Disconnect control signal cable and 120VAC supply cable from module.

#### Power Module Removal (cont'd)

5. Pull slide tray out until slides lock.
6. Remove four "C" bolts which secure module to tray.
7. Using module lifting attachment and lifter, lift module from tray.

#### Power Module Installation

1. Pull slide tray out until slides lock.
2. Using module lifting attachment and lifter, place module on tray.
3. Secure module to tray with four "C" bolts.
4. Press slide release buttons and slide module into compartment (use caution).
5. Reconnect control signal cable and 120VAC supply cable to module connectors.
6. Reinstall control wiring cover and secure with two "A" & two "B" bolts.
7. Reconnect power cables ACL, P, C & N.
8. Reinstall AC neutral bus.
9. Torque all power connections (5/16-18 hdwr) to 10-15 ft-lbs.

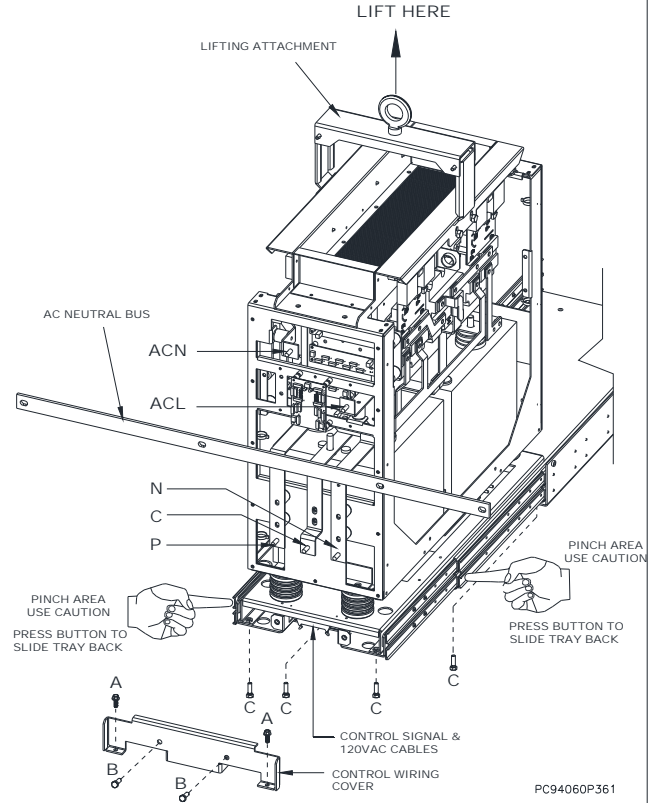

PC94060P361

## DRIVE INSTALLATION DRAWINGS (cont'd)

### Frame B4 drive lifting and assembly

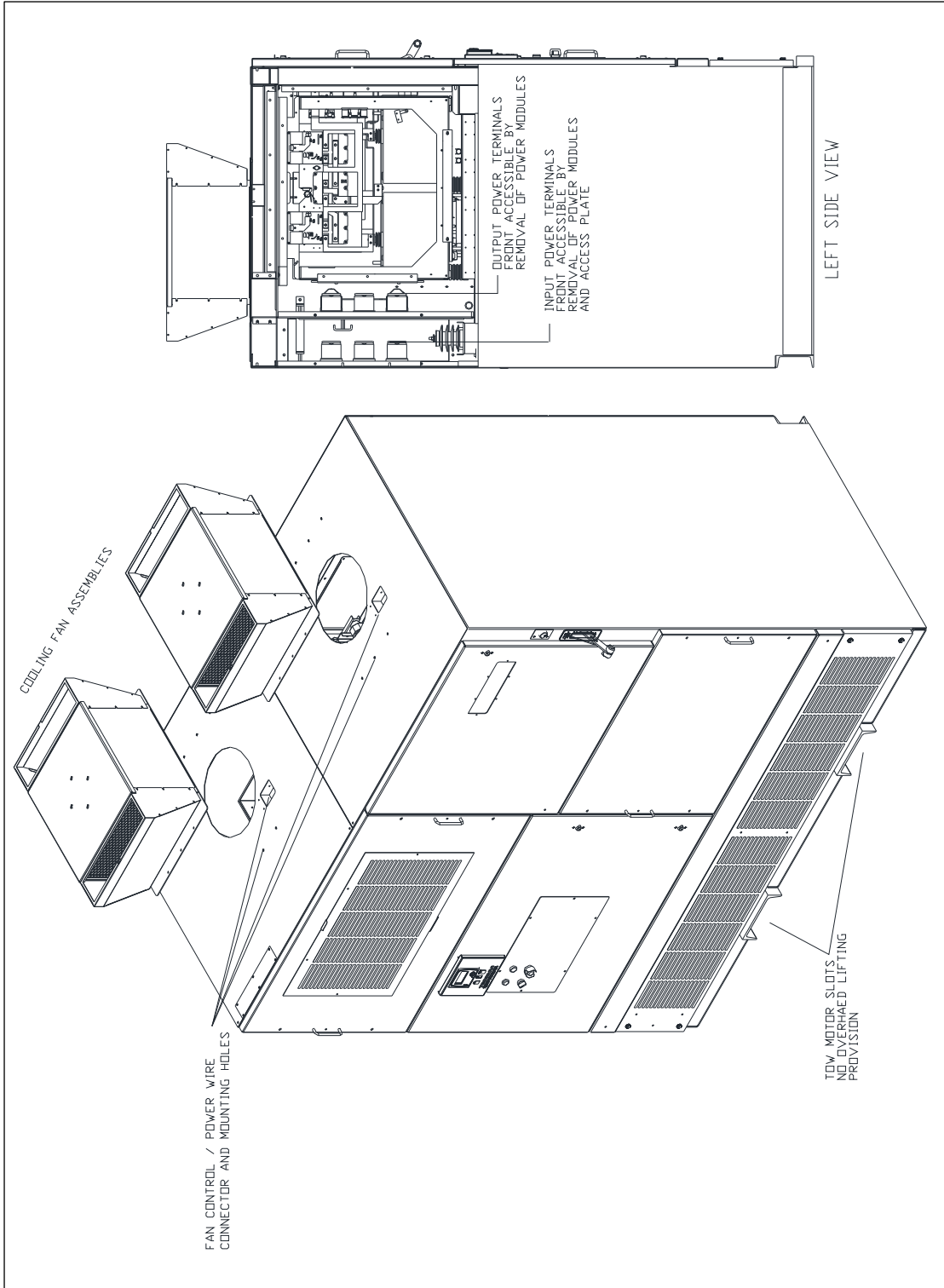

## DRIVE INSTALLATION DRAWINGS (cont'd)

### Frame B6S module lifting and installation

#### WARNINGS

Inverter cabinet is top heavy. Cabinet must be anchored to floor before withdrawing power modules to prevent tipping.

Disconnect power and wait 15 minutes to ensure capacitors are discharged before performing inspection or maintenance.

Improper handling of the fiber optic cables and connectors may cause drive failure due to problems transmitting signals. Take care not to disturb fiber optic cables when handling power module.

GCI6731G050B power modules can only be used in the upper power module position. GCI6721G050B2 power modules can be used in the upper or lower module position. In the upper position GCI6721G050B2 will have 4 bus connections and no 24C connection.

Use module lifting attachment GCI6721G055 and a lifting device rated 350 lbs minimum for removal and installation of modules.

#### GCI6731G050B

##### Upper Power Module Removal

1. Disconnect power cables ACL, P, C & N (P, C & N on left module only).
2. Disconnect and remove bus bars P, C & N.
3. Remove control wiring cover (two "A" bolts).
4. Disconnect control signal cable and 120VAC supply cable from module.
5. Free slide tray by removing bolt "B".
6. Pull slide tray out until slides lock.
7. Remove four "C" bolts which secure module to tray.
8. Using module lifting attachment and lifter, lift module from tray.

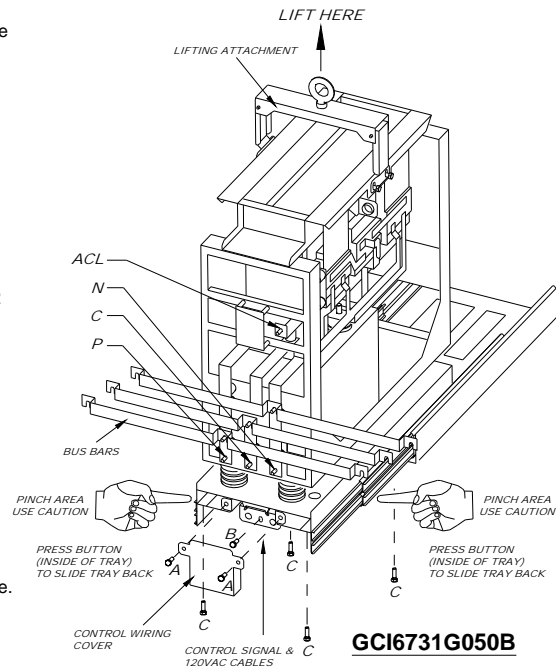

#### GCI6721G050B2

##### Lower Power Module Removal

1. Disconnect power cables ACN, 24C, P, C, N & ACL.
2. Remove control wiring cover (two "A" bolts).
3. Disconnect control signal cable and 120VAC supply cable from module.
4. Free slide tray by removing bolt "B".
5. Pull slide tray out until slides lock.
6. Remove four "C" bolts which secure module to tray.
7. Using module lifting attachment and lifter, lift module from tray.

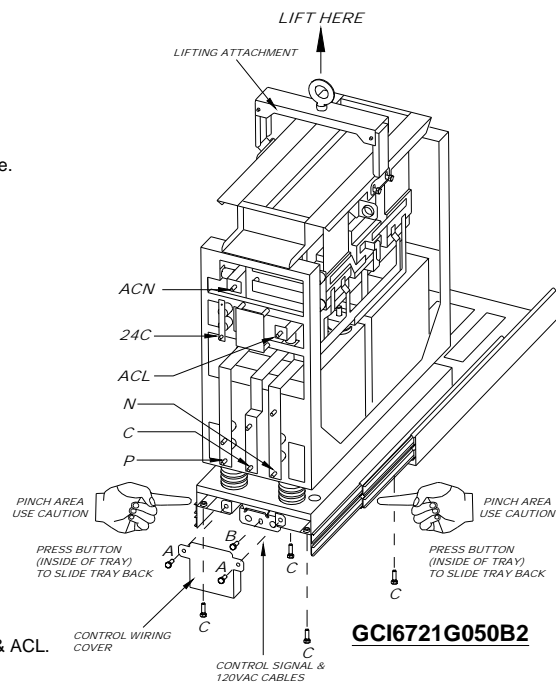

#### Power Module Installation

1. Pull slide tray out until slides lock.
2. Using module lifting attachment and lifter place module on tray.
3. Secure module to tray with four "C" bolts.
4. Press slide release buttons and slide module into compartment. (Use caution).
5. Reinstall bolt "B" to secure tray in position.
6. Reconnect control signal cable and 120VAC supply cable to module connectors.
7. Reinstall control wiring cover and secure with two "A" bolts.
8. Upper Power Module: Reinstall bus bars P, C & N.
9. Upper Power Module: Reconnect power cables ACL, P, C & N (P,C & N on middle module only).
10. Lower Power Module: Reconnect power cables ACN, 24C, P, C,N & ACL.
11. Torque all power connections (5/16-18 hardware) to 10-15 ft-lbs.

PC94060P220

## DRIVE INSTALLATION DRAWINGS (cont'd)

### Frame B6S drive lifting and assembly

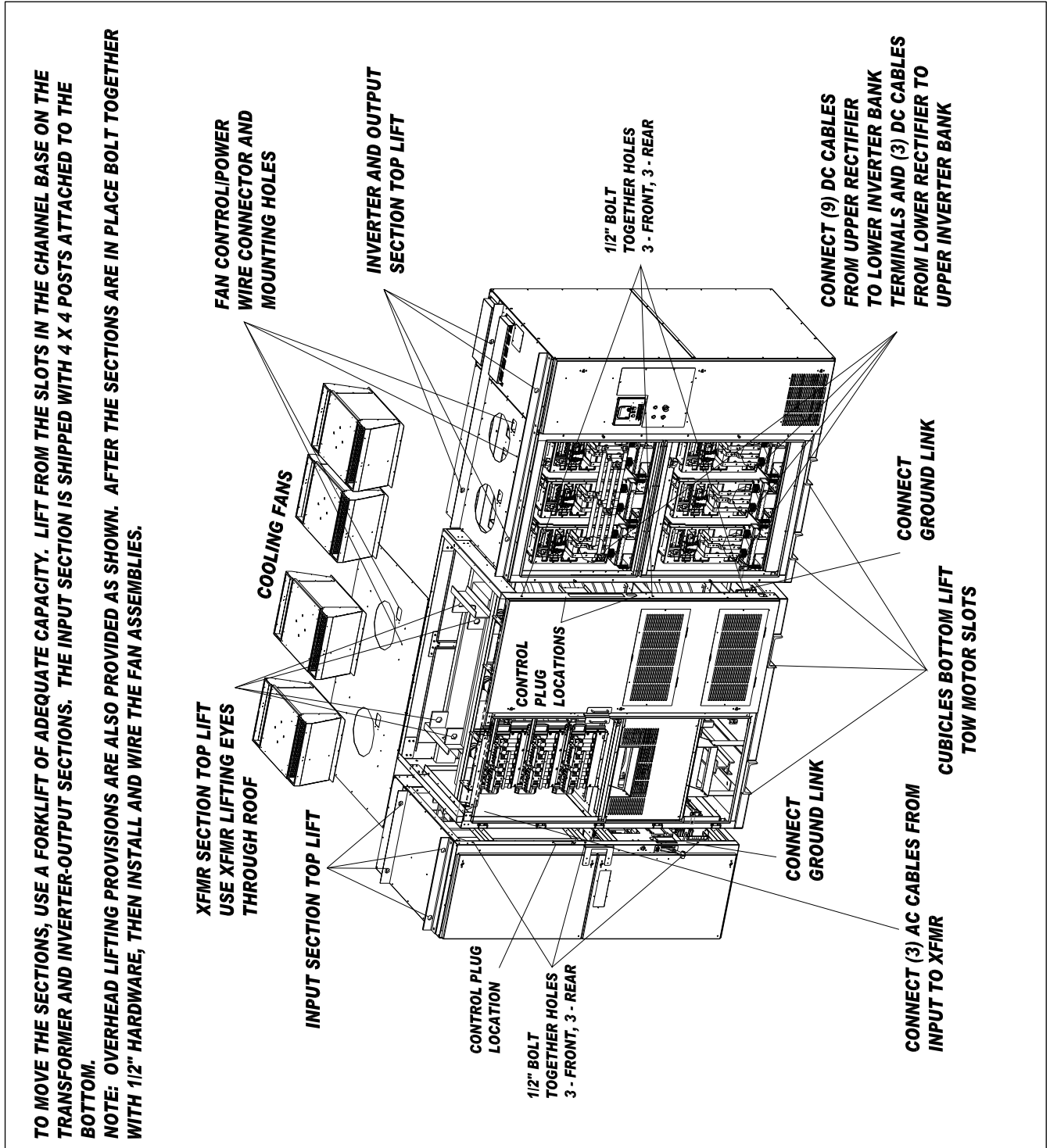

**DRIVE INSTALLATION DRAWINGS (cont'd)**

**Frame B6S drive main terminal locations**

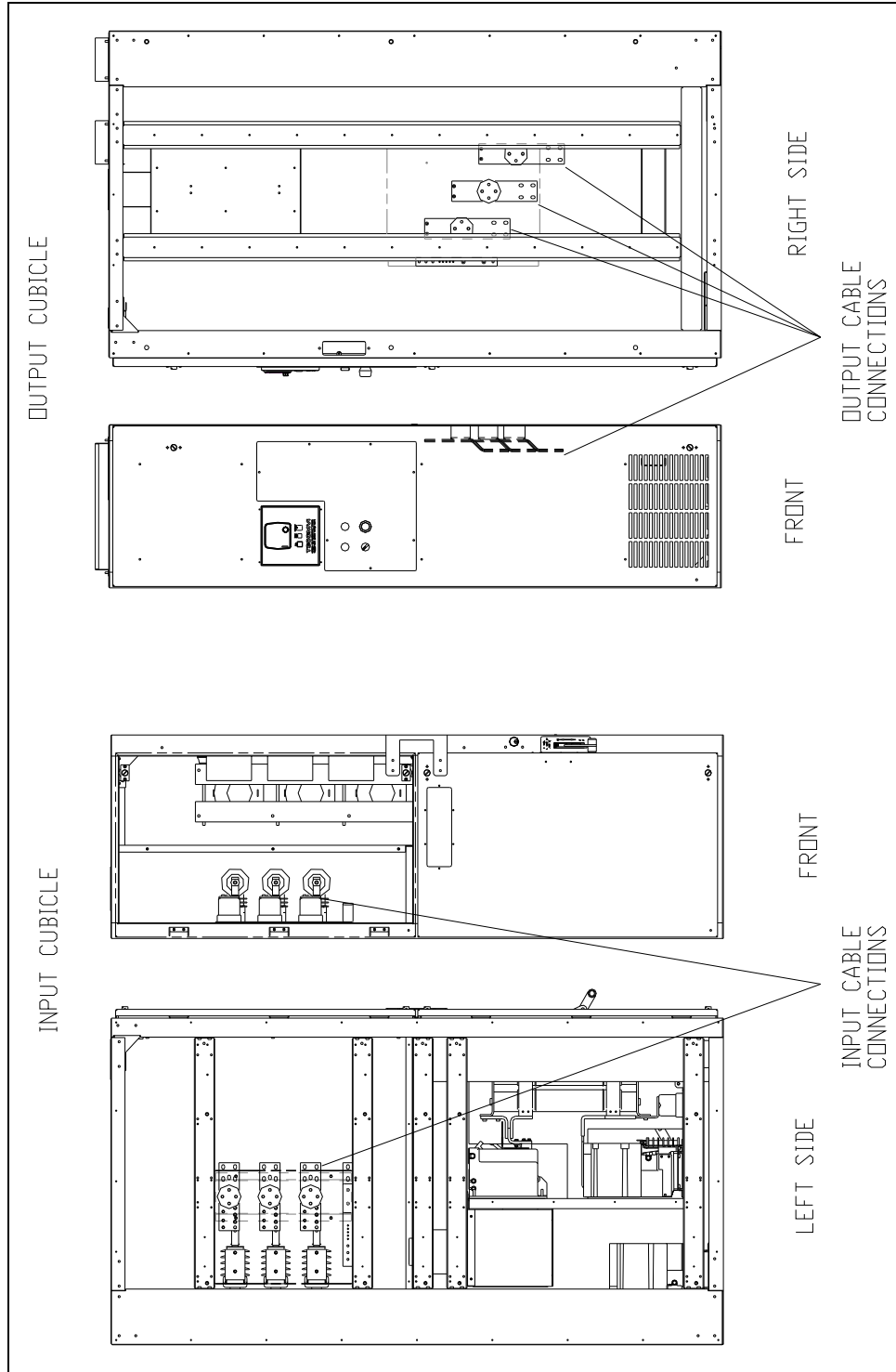

## DRIVE INSTALLATION DRAWINGS (cont'd)

### Frame C6S module lifting and installation

#### WARNINGS

Disconnect power and wait 15 minutes to ensure capacitors are discharged before performing inspection or maintenance.

Improper handling of the fiber optic cables and connectors may cause drive failure due to problems transmitting signals. Take care not to disturb fiber optic cables when handling power module.

#### GCI6732G050A

##### Power Module Disconnection

1. Remove front barrier (four bolts).
2. Loosen eight nuts and remove bus link assembly by sliding sideways and off.
3. Remove control wiring cover (two bolts)
4. Disconnect control signal cable and 120VAC supply cable from module
5. GCI6732G050A can be used in the upper PM compartment only.

#### GCI6722G050A2

##### Power Module Disconnection

1. Remove front barrier (four bolts).
2. Disconnect 24C terminal cable and slide out of bushing bracket.
3. Loosen ten nuts and remove bus link assembly by sliding sideways and off.
4. Remove control wiring cover (two bolts)
5. Disconnect control signal cable and 120VAC supply cable from module.
6. GCI6722G050A2 may be used in the upper or lower PM compartment. When used in the upper compartment, there will be 4 links in the bus link assembly and no 24C cable connection.

##### Power Module Removal

1. Use Only Lifter PC10480P910 for removal & installation of modules
2. Position lifter squarely in front of cubicle. Raise tray of lifter PC10480P910 above Power Module support pan. Lower tray, inserting pins or tabs into holes in front edge of support pan. (A) Set truck brake.
3. Withdraw Power Module onto lifter tray. Secure Power Module to tray by connecting chains to Power Module frames (B).
4. Raise tray to until tabs or pins are clear of support pan edge. Slowly move lifter back, away from cubicle. Use crank to slowly lower Power Module to the floor.

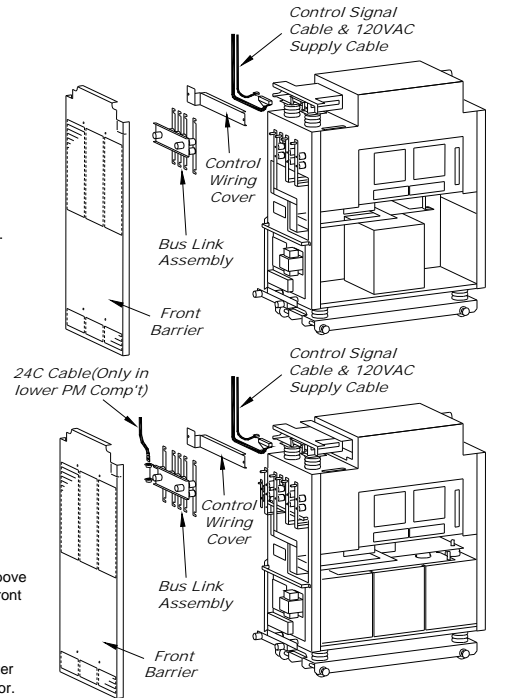

PC94060P216

#### Power Module Installation

1. Lower lifter tray to ground. Roll Power Module onto tray. Secure with chains.(B)
2. Raise tray above Power Module support pan. Lower tray, inserting tabs or pins into holes in front edge of support pan. (A) Set truck brake.
3. Unlatch chains. Roll Power Module from truck onto enclosure rails.

#### Power Module Reconnection

1. Reverse the procedure followed during disconnection and removal of power module.
2. Ensure that control signal cable, 120VAC supply cable and 24C cable, if required, are properly reconnected.
3. Reinstall all hardware previously removed.
4. Torque bus link connections (5/16-18 hdwr) to 10-15 ft-lbs.

#### Lifting PMs Outside the Cubicle

For lifting Power Module GCI673FG050 use Lifting Attachment GCI6722G055 and a lifting device rated at 1000 lbs. or more. Secure Lifting Attachment to Power Module with (4) 5/16-18 Bolts.

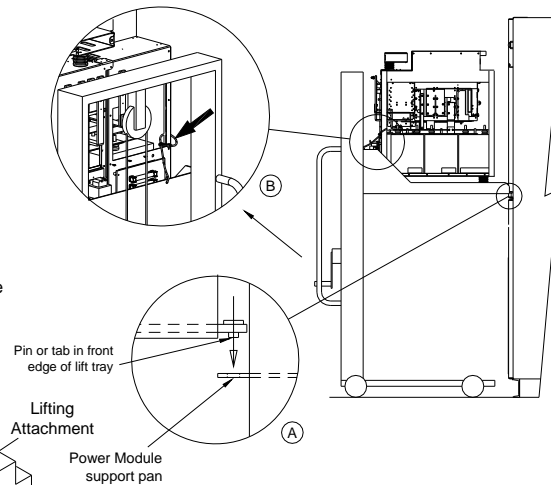
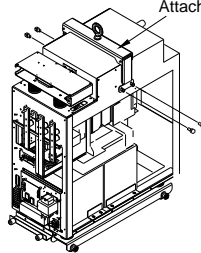

PC94060P215



## DRIVE INSTALLATION DRAWINGS (cont'd)

### Frame C6S drive main terminal locations

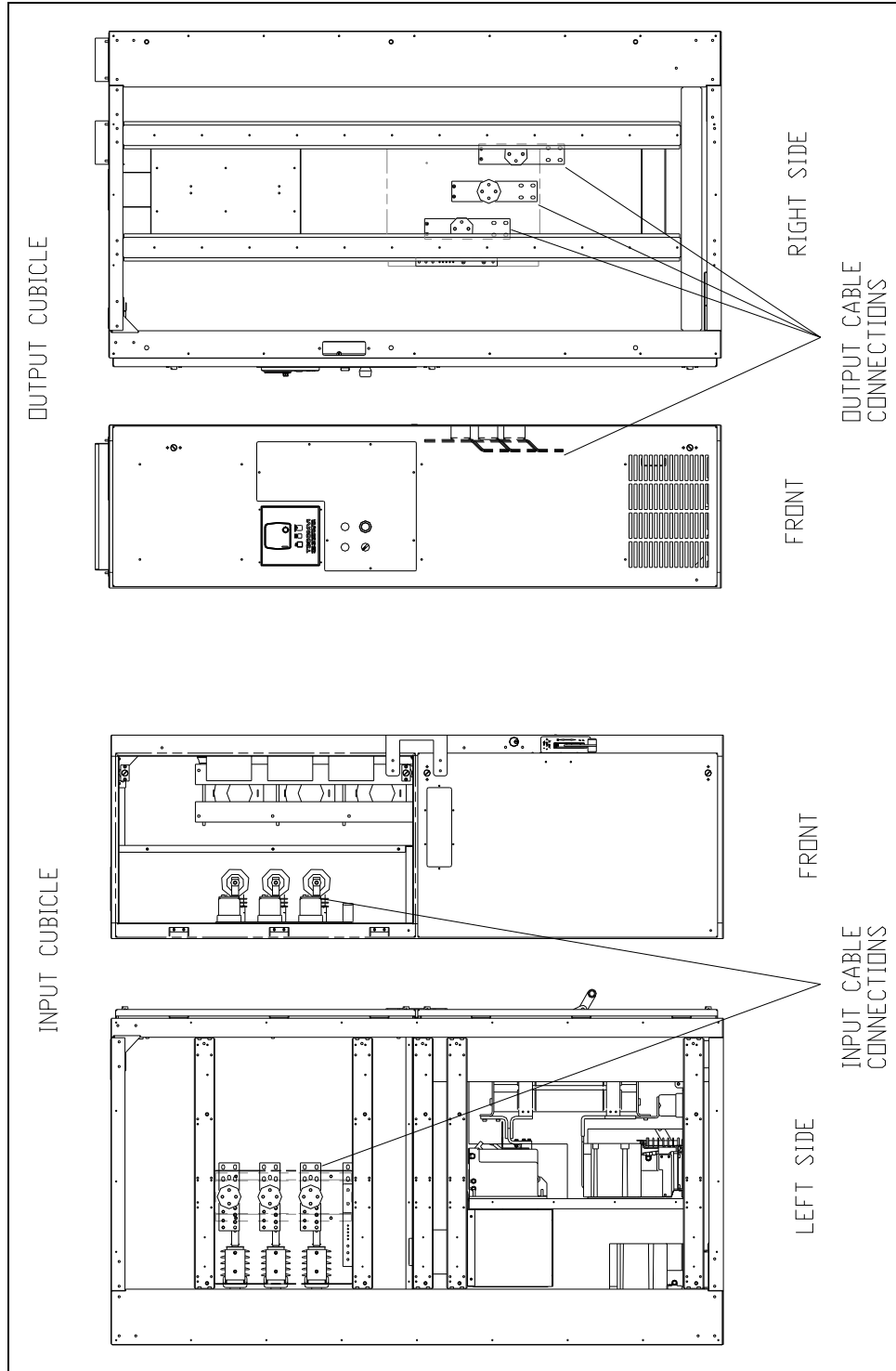

## DRIVE INSTALLATION DRAWINGS (cont'd)

### Frame D6S module lifting and installation

**WARNINGS**

Disconnect power and wait 15 minutes to ensure capacitors are discharged before performing inspection or maintenance.

Improper handling of the fiber optic cables and connectors may cause drive failure due to problems transmitting signals. Take care not to disturb fiber optic cables when handling power module.

Use Lift PC10480P910 for removal & installation of modules

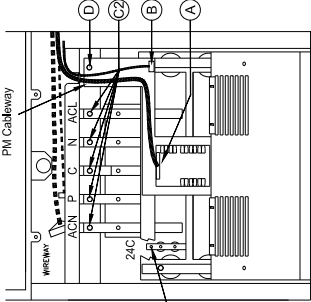

GCI6723G05A2  
Can be used in Upper or Lower Comp't.  
(with no ACN or 24C connection; the in lower position)

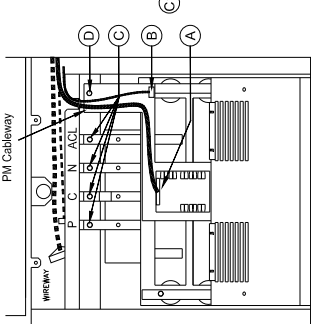

GCI6733G050  
Can only be used in Upper Comp't.

**Power Module Removal**

1. After capacitor discharge, open upper Power Module cover.
2. Disconnect Control Cable from PCB 'A' and lay in wireway above Power Module (PM).
3. Disconnect Control Power Cable 'B'; lay in wireway above PM.
4. In the Upper Comp't; Remove (4) bolts 'C' from bus stabs P, C, N & ACL.
5. In the Lower Comp't; Remove 24C Cable 'C1' from 24C terminal and lay in wireway above PM.
6. Remove (5) bolts 'C2' from bus stabs ACN, P, C, N & ACL.
7. In the Upper & Lower Comp'ts; Remove (1) bolt 'D' from back of Power Module cableway.
8. Raise tray of lifter PC10480P910 above Power Module support pan. Lower tray inserting tray pins into holes in front edge of support pan. (E) Set truck brake.
9. Withdraw Power Module by handles onto tray. Secure Power Module to tray by connecting chains to Power Module handles.(F)
10. Raise tray to until pins are clear of mounting pan. Slowly move lifter back, away from cubicle. Use crank to slowly lower Power Module to the floor.

PC94060P217

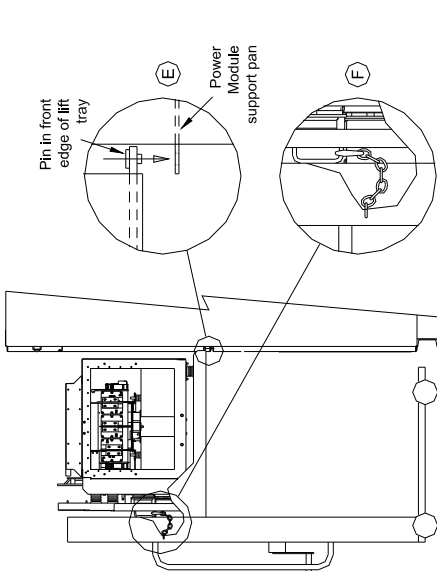

Pin in front edge of lift tray

Power Module support pan

**Power Module Installation**

1. Lower lifter tray to ground. Roll Power Module onto tray. Secure with chains.(F)
2. Raise tray above Power Module support pan. Lower tray, inserting pins into holes in front edge of support pan. (E) Set truck brake.
3. Unlatch chains. Roll Power Module by handles from truck onto enclosure rail until enclosure and Power Module bus stabs touch.
4. Install (1) bolt 'D' at back of cableway. Unlatch, remove truck.
5. Install (4 or 5) bolts 'C/C2' through bus stabs ACN, P, C, N & ACL. Torque all power connections (5/16-18 hdwr) to 10-15 ft-lbs.
6. Connect 24C Cable to 24C terminal as shown at 'C1'.
7. Connect Control Power Cable from wireway as shown at 'B'.
8. Connect Control Cable from wireway to PCB as shown at 'A'.
9. Close upper Power Module cover. Secure with 2 bolts.
10. Replace outside filter cover.

For lifting the Power Module after it is out of the Cubicle use Lifting Attachment GCI6723G054 and a lifting device rated at 1000 lbs. or more.

Secure Lifting Attachment to Power Module with (4) 1/2-13 Bolts.

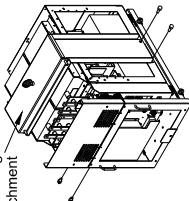

Lifting Attachment

PC94060P218



**DRIVE INSTALLATION DRAWINGS (cont'd)**

**Frame D6S drive main terminal locations**

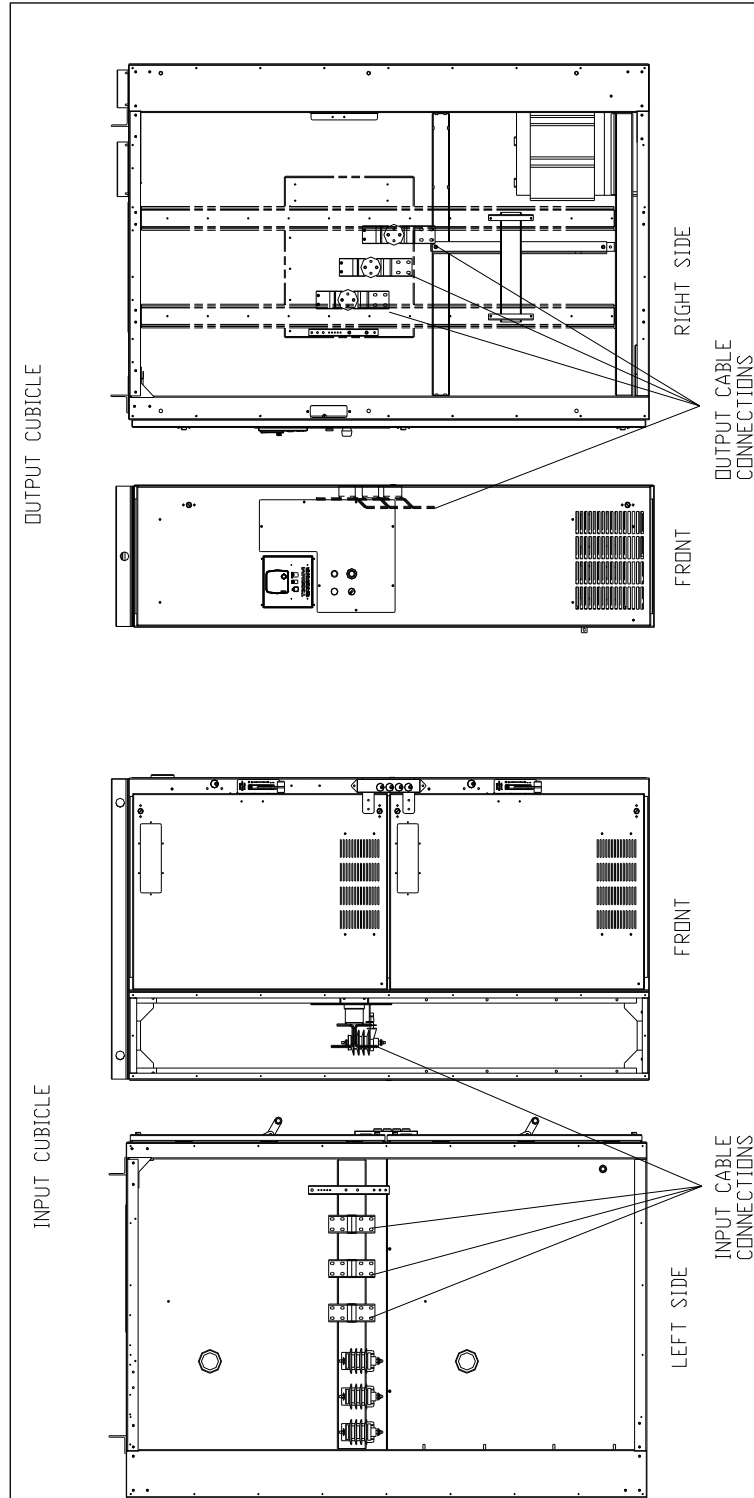

## DRIVE INSTALLATION DRAWINGS (cont'd)

### Frame F6S & F6S+ module lifting and installation

**WARNINGS**

Disconnect power and wait 15 minutes to ensure capacitors are discharged before performing inspection or maintenance.

Improper handling of the fiber optic cables and connectors may cause drive failure due to problems transmitting signals. Take care not to disturb fiber optic cables when handling power module.

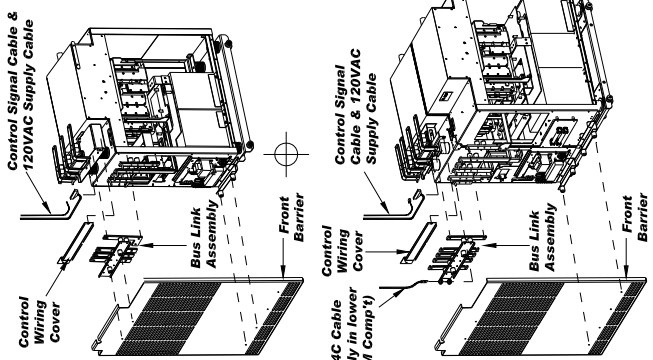

**GC1673FG050 Power Module Disconnection**

1. Remove front barrier (four bolts).
2. Loosen four top nuts, remove bottom four nuts and remove bus link assembly.
3. Remove control wiring cover (two bolts)
4. Disconnect control signal cable and 120VAC supply cable from module
5. GC1673FG050 can be used in the upper PM compartment only.

**GC16724G050A2 Power Module Disconnection**

1. Remove front barrier (six bolts).
2. Disconnect 24C terminal cable and slide out of bushing bracket.
3. Loosen ten nuts and remove bus link assembly by sliding sideways and off.
4. Remove control wiring cover (two bolts)
5. Disconnect control signal cable and 120VAC supply cable from module.
6. GC16724G050A2 may be used in the upper or lower PM compartment. When used in the upper compartment, there will be 4 links in the bus link assembly and no 24C cable connection.

**Power Module Removal**

1. Use Only Lifter PC10480P910 for removal & installation of modules
2. Position lifter squarely in front of cubicle. Raise tray of lifter PC10480P910 above Power Module support pan. Lower tray inserting tray pins into holes in front edge of support pan. (A) Set truck brake.
3. Withdraw Power Module onto lifter tray. Secure Power Module to tray by connecting chains to Power Module handles (B), one handle for GC1673FG050, two for GC16724G050A2.
4. Raise tray to until pins are clear of support pan. Slowly move lifter back, away from cubicle. Use crank to slowly lower Power Module to the floor.

PC94060P208

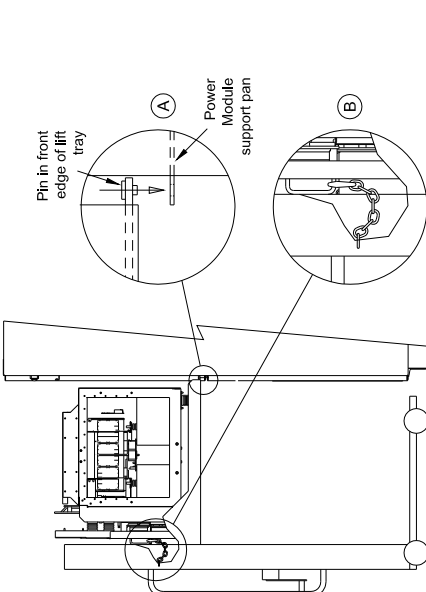

**Power Module Installation**

1. Lower lifter tray to ground. Roll Power Module onto tray. Secure with chains.(B)
2. Raise tray above Power Module support pan. Lower tray, inserting pins into holes in front edge of support pan. (A) Set truck brake.
3. Unlatch chains. Roll Power Module from truck onto enclosure rails.

**Power Module Reconnection**

1. Reverse the procedure followed during disconnection and removal of power module.
2. Ensure that control signal cable, 120VAC supply cable and 24C cable, if required, are properly reconnected.
3. Reinstall all hardware previously removed.
4. Torque bus link connections (5/16-18 hdwr) to 10-15 ft-lbs.

**Lifting PMs Outside the Cubicle**

For lifting Power Module GC1673FG050 use Lifting Attachment GC16722G055 and a lifting device rated at 1000 lbs. or more. Secure Lifting Attachment to Power Module with (4) 5/16-18 Bolts.

For lifting Power Module GC16724G050A2 use Lifting Attachment GC16724G055 and a lifting device rated at 1000 lbs. or more. Secure Lifting Attachment to Power Module with (4) 1/2 -13 Bolts.

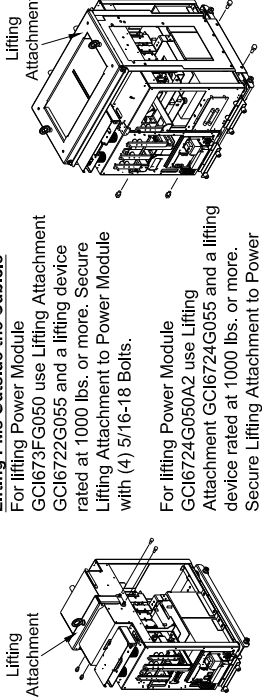

PC94060P209

## DRIVE INSTALLATION DRAWINGS (cont'd)

### Frame F6S drive lifting and assembly

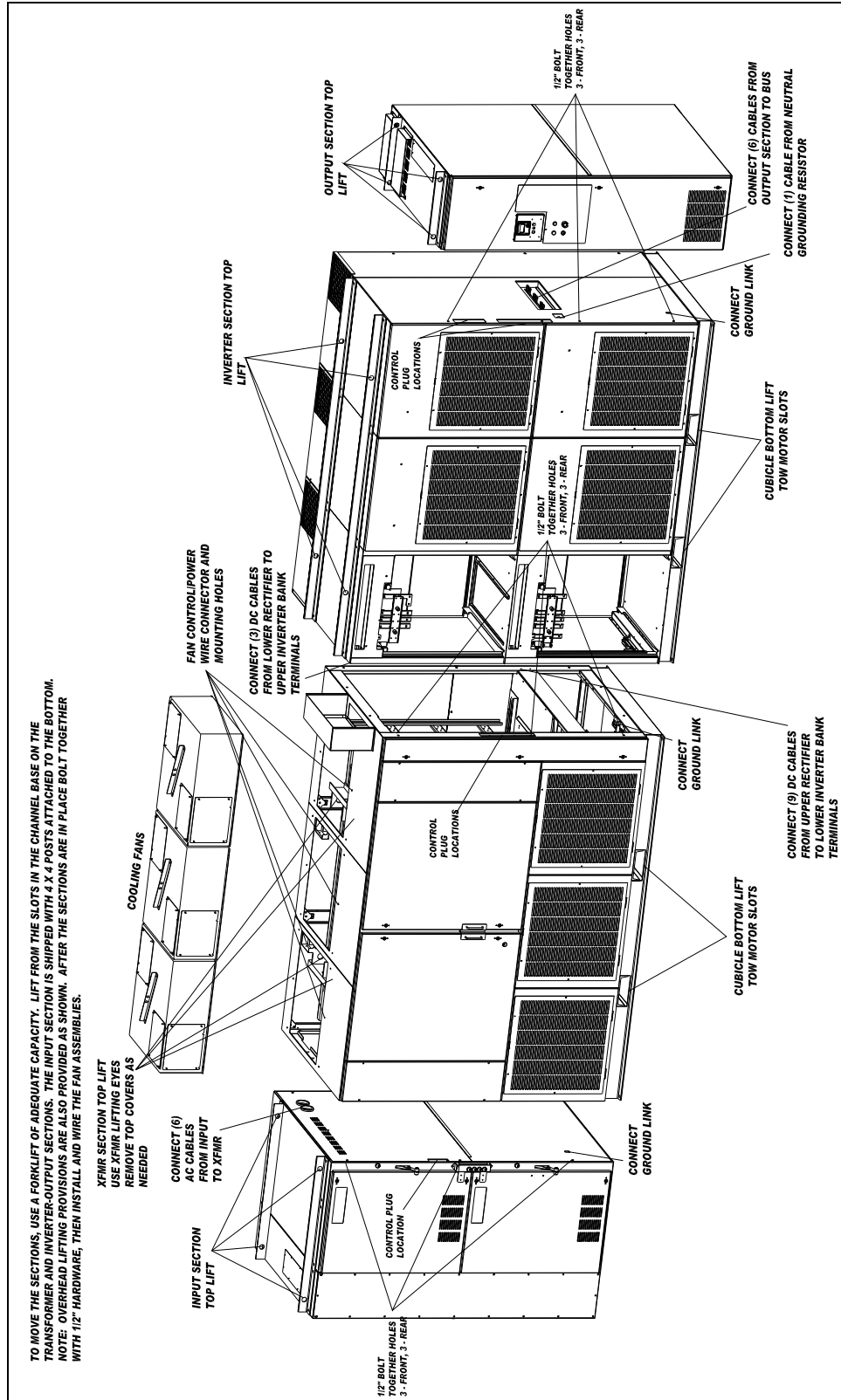



**DRIVE INSTALLATION DRAWINGS (cont'd)**

**Frame F6S & F6S+ drive main terminal locations**

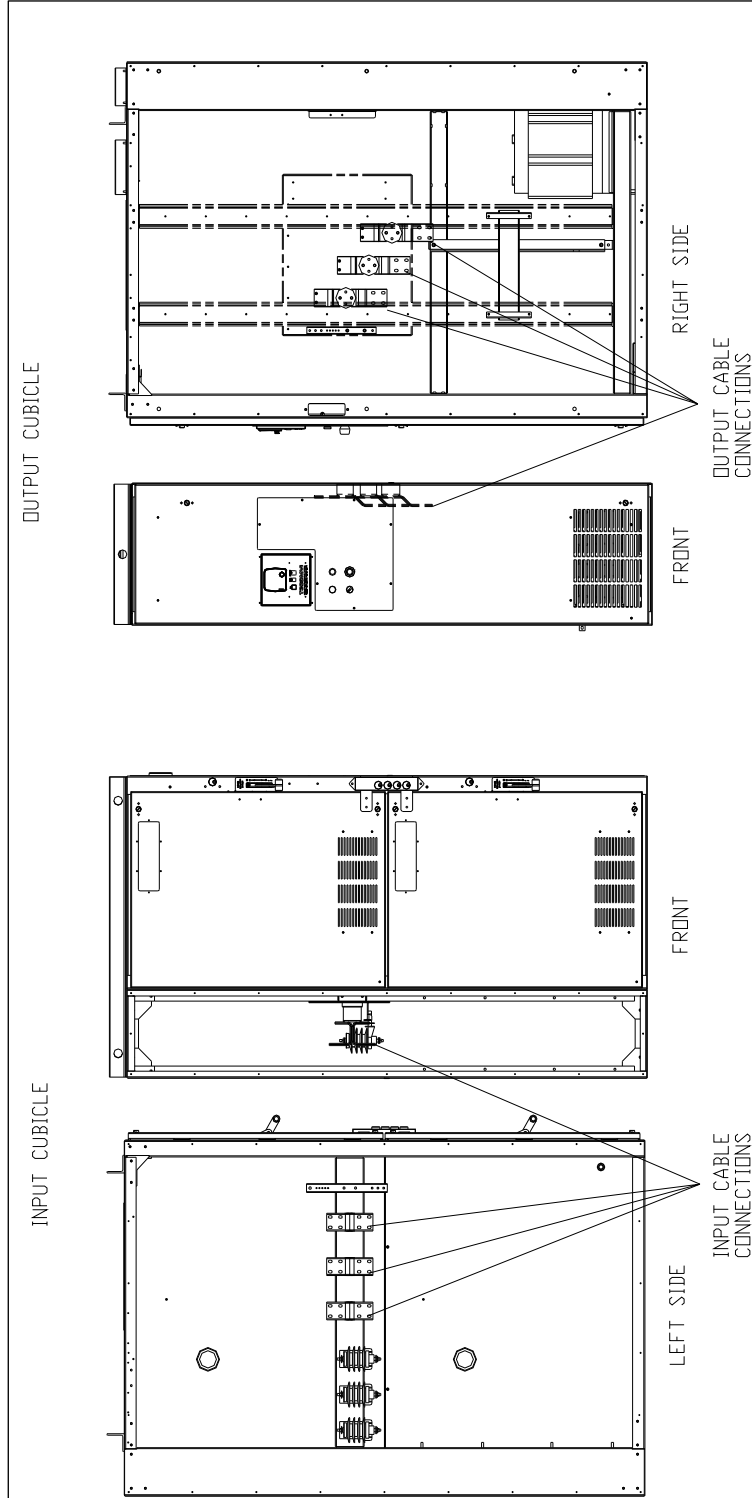

## DRIVE INSTALLATION DRAWINGS (cont'd)

### Frame MTX15 drive lifting and assembly

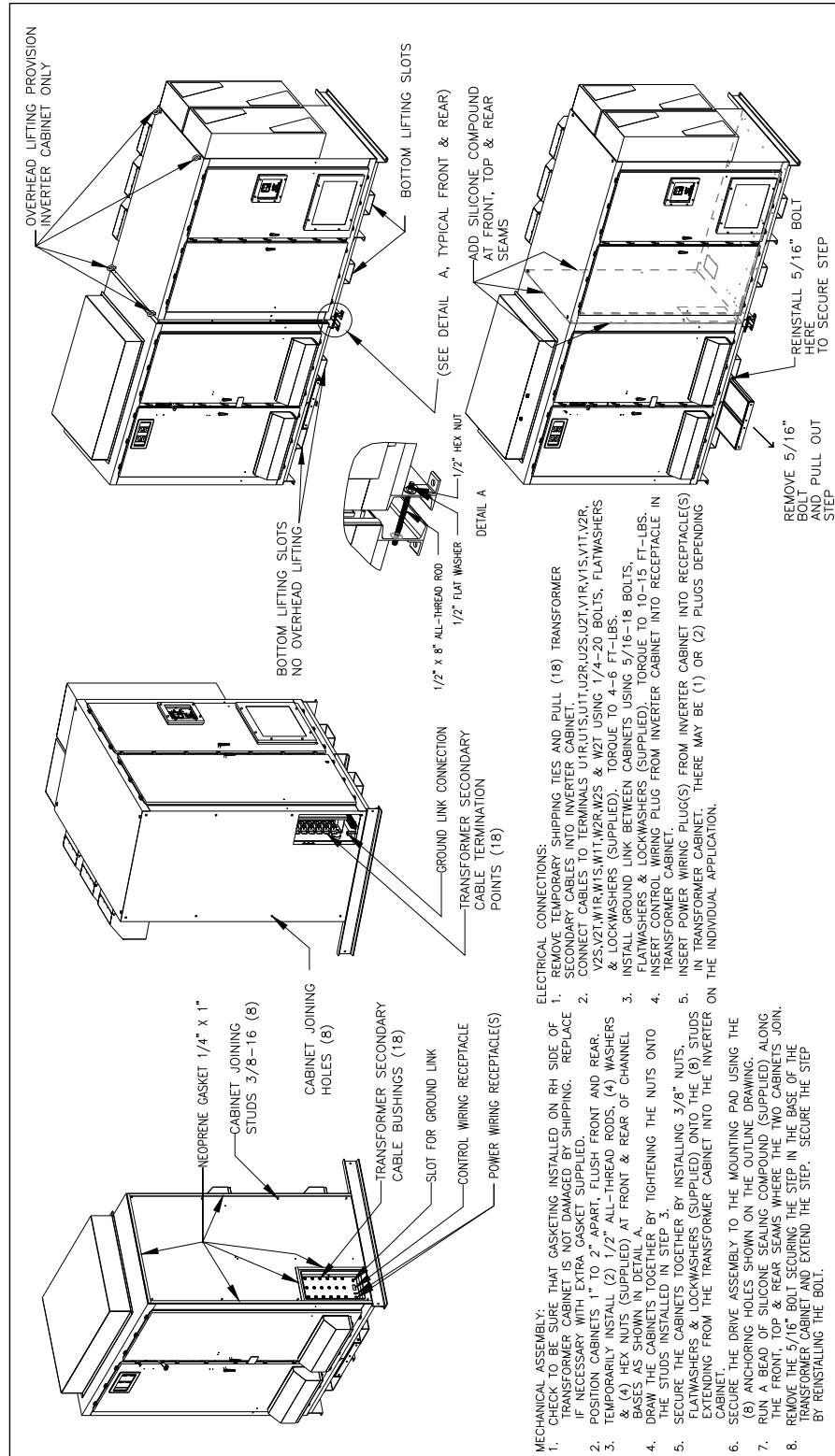



TOSHIBA INTERNATIONAL CORPORATION  
13131 WEST LITTLE YORK  
HOUSTON, TEXAS 77041 USA

[www.toshiba.com/ind](http://www.toshiba.com/ind)

Telephone: 713-466-0277  
800-231-1412  
800-527-1204 (Canada)  
Fax: 713-466-8773

Printed in U.S.A.